

ETSI TS 136 101 V12.27.0 (2021-09)



**LTE;
Evolved Universal Terrestrial Radio Access (E-UTRA);
User Equipment (UE) radio transmission and reception
(3GPP TS 36.101 version 12.27.0 Release 12)**



Reference

RTS/TSGR-0436101vcr0

Keywords

LTE

ETSI

650 Route des Lucioles
F-06921 Sophia Antipolis Cedex - FRANCE

Tel.: +33 4 92 94 42 00 Fax: +33 4 93 65 47 16

Siret N° 348 623 562 00017 - APE 7112B
Association à but non lucratif enregistrée à la
Sous-Préfecture de Grasse (06) N° w061004871

Important notice

The present document can be downloaded from:

<http://www.etsi.org/standards-search>

The present document may be made available in electronic versions and/or in print. The content of any electronic and/or print versions of the present document shall not be modified without the prior written authorization of ETSI. In case of any existing or perceived difference in contents between such versions and/or in print, the prevailing version of an ETSI deliverable is the one made publicly available in PDF format at www.etsi.org/deliver.

Users of the present document should be aware that the document may be subject to revision or change of status.

Information on the current status of this and other ETSI documents is available at

<https://portal.etsi.org/TB/ETSIDeliverableStatus.aspx>

If you find errors in the present document, please send your comment to one of the following services:

<https://portal.etsi.org/People/CommitteeSupportStaff.aspx>

Notice of disclaimer & limitation of liability

The information provided in the present deliverable is directed solely to professionals who have the appropriate degree of experience to understand and interpret its content in accordance with generally accepted engineering or other professional standard and applicable regulations.

No recommendation as to products and services or vendors is made or should be implied.

No representation or warranty is made that this deliverable is technically accurate or sufficient or conforms to any law and/or governmental rule and/or regulation and further, no representation or warranty is made of merchantability or fitness for any particular purpose or against infringement of intellectual property rights.

In no event shall ETSI be held liable for loss of profits or any other incidental or consequential damages.

Any software contained in this deliverable is provided "AS IS" with no warranties, express or implied, including but not limited to, the warranties of merchantability, fitness for a particular purpose and non-infringement of intellectual property rights and ETSI shall not be held liable in any event for any damages whatsoever (including, without limitation, damages for loss of profits, business interruption, loss of information, or any other pecuniary loss) arising out of or related to the use of or inability to use the software.

Copyright Notification

No part may be reproduced or utilized in any form or by any means, electronic or mechanical, including photocopying and microfilm except as authorized by written permission of ETSI.

The content of the PDF version shall not be modified without the written authorization of ETSI.

The copyright and the foregoing restriction extend to reproduction in all media.

© ETSI 2021.
All rights reserved.

Intellectual Property Rights

Essential patents

IPRs essential or potentially essential to normative deliverables may have been declared to ETSI. The declarations pertaining to these essential IPRs, if any, are publicly available for **ETSI members and non-members**, and can be found in ETSI SR 000 314: "*Intellectual Property Rights (IPRs); Essential, or potentially Essential, IPRs notified to ETSI in respect of ETSI standards*", which is available from the ETSI Secretariat. Latest updates are available on the ETSI Web server (<https://ipr.etsi.org/>).

Pursuant to the ETSI Directives including the ETSI IPR Policy, no investigation regarding the essentiality of IPRs, including IPR searches, has been carried out by ETSI. No guarantee can be given as to the existence of other IPRs not referenced in ETSI SR 000 314 (or the updates on the ETSI Web server) which are, or may be, or may become, essential to the present document.

Trademarks

The present document may include trademarks and/or tradenames which are asserted and/or registered by their owners. ETSI claims no ownership of these except for any which are indicated as being the property of ETSI, and conveys no right to use or reproduce any trademark and/or tradename. Mention of those trademarks in the present document does not constitute an endorsement by ETSI of products, services or organizations associated with those trademarks.

DECT™, **PLUGTESTS™**, **UMTS™** and the ETSI logo are trademarks of ETSI registered for the benefit of its Members. **3GPP™** and **LTE™** are trademarks of ETSI registered for the benefit of its Members and of the 3GPP Organizational Partners. **oneM2M™** logo is a trademark of ETSI registered for the benefit of its Members and of the oneM2M Partners. **GSM®** and the GSM logo are trademarks registered and owned by the GSM Association.

Legal notice

This Technical Specification (TS) has been produced by the ETSI 3rd Generation Partnership Project (3GPP).

The present document may refer to technical specifications or reports using their 3GPP identities. These shall be interpreted as being references to the corresponding ETSI deliverables.

The cross reference between 3GPP and ETSI identities can be found under <http://webapp.etsi.org/key/queryform.asp>.

Modal verbs terminology

In the present document "**shall**", "**shall not**", "**should**", "**should not**", "**may**", "**need not**", "**will**", "**will not**", "**can**" and "**cannot**" are to be interpreted as described in clause 3.2 of the [ETSI Drafting Rules](#) (Verbal forms for the expression of provisions).

"**must**" and "**must not**" are **NOT** allowed in ETSI deliverables except when used in direct citation.

Contents

Intellectual Property Rights	2
Legal notice	2
Modal verbs terminology.....	2
Foreword.....	19
1 Scope	20
2 References	20
3 Definitions, symbols and abbreviations	20
3.1 Definitions	20
3.2 Symbols.....	22
3.3 Abbreviations	24
4 General	25
4.1 Relationship between minimum requirements and test requirements	25
4.2 Applicability of minimum requirements	26
4.3 Void.....	26
4.3A Applicability of minimum requirements (CA, UL-MIMO, ProSe, Dual Connectivity, UE category 0).....	26
4.4 RF requirements in later releases	27
5 Operating bands and channel arrangement.....	27
5.1 General	27
5.2 Void.....	27
5.3 Void.....	27
5.4 Void.....	27
5.5 Operating bands.....	27
5.5A Operating bands for CA	29
5.5B Operating bands for UL-MIMO	34
5.5C Operating bands for Dual Connectivity.....	34
5.5D Operating bands for ProSe.....	36
5.5E Operating bands for UE category 0	36
5.6 Channel bandwidth.....	36
5.6.1 Channel bandwidths per operating band.....	37
5.6A Channel bandwidth for CA.....	38
5.6A.1 Channel bandwidths per operating band for CA.....	41
5.6B Channel bandwidth for UL-MIMO	51
5.6B.1 Void	51
5.6C Channel bandwidth for Dual Connectivity	51
NOTE 2: For TDD inter-band dual connectivity configurations, requirements are applicable only for synchronous operation.5.6C.1.....	Void
5.6D Channel bandwidth for ProSe.....	52
5.6D.1 Channel bandwidths per operating band for ProSe.....	52
5.7 Channel arrangement.....	52
5.7.1 Channel spacing	52
5.7.1A Channel spacing for CA.....	53
5.7.2 Channel raster	53
5.7.2A Channel raster for CA	53
5.7.3 Carrier frequency and EARFCN.....	53
5.7.4 TX–RX frequency separation	54
5.7.4A TX–RX frequency separation for CA	55
6 Transmitter characteristics	55
6.1 General	55
6.2 Transmit power	56
6.2.1 Void	56

6.2.2	UE maximum output power.....	56
6.2.2A	UE maximum output power for CA.....	57
6.2.2B	UE maximum output power for UL-MIMO.....	59
6.2.3	UE maximum output power for modulation / channel bandwidth.....	61
6.2.3A	UE Maximum Output power for modulation / channel bandwidth for CA.....	61
6.2.3B	UE maximum output power for modulation / channel bandwidth for UL-MIMO.....	63
6.2.3D	UE maximum output power for modulation / channel bandwidth for ProSe.....	63
6.2.4	UE maximum output power with additional requirements.....	63
6.2.4A	UE maximum output power with additional requirements for CA.....	73
6.2.4A.1	A-MPR for CA_NS_01 for CA_1C.....	74
6.2.4A.2	A-MPR for CA_NS_02 for CA_1C.....	75
6.2.4A.3	A-MPR for CA_NS_03 for CA_1C.....	76
6.2.4A.4	A-MPR for CA_NS_04.....	76
6.2.4A.5	A-MPR for CA_NS_05 for CA_38C.....	77
6.2.4A.6	A-MPR for CA_NS_06.....	78
6.2.4A.7	A-MPR for CA_NS_07.....	79
6.2.4A.8	A-MPR for CA_NS_08.....	80
6.2.4B	UE maximum output power with additional requirements for UL-MIMO.....	81
6.2.4D	UE maximum output power with additional requirements for ProSe.....	82
6.2.5	Configured transmitted power.....	82
6.2.5A	Configured transmitted power for CA.....	89
6.2.5B	Configured transmitted power for UL-MIMO.....	91
6.2.5C	Configured transmitted power for Dual Connectivity.....	92
6.2.5D	Configured transmitted power for ProSe.....	93
6.3	Output power dynamics.....	94
6.3.1	(Void).....	94
6.3.2	Minimum output power.....	94
6.3.2.1	Minimum requirement.....	94
6.3.2A	UE Minimum output power for CA.....	94
6.3.2A.1	Minimum requirement for CA.....	94
6.3.2B	UE Minimum output power for UL-MIMO.....	95
6.3.2B.1	Minimum requirement.....	95
6.3.3	Transmit OFF power.....	95
6.3.3.1	Minimum requirement.....	95
6.3.3A	UE Transmit OFF power for CA.....	96
6.3.3A.1	Minimum requirement for CA.....	96
6.3.3B	UE Transmit OFF power for UL-MIMO.....	96
6.3.3B.1	Minimum requirement.....	96
6.3.3D	Transmit OFF power for ProSe.....	96
6.3.4	ON/OFF time mask.....	97
6.3.4.1	General ON/OFF time mask.....	97
6.3.4.2	PRACH and SRS time mask.....	97
6.3.4.2.1	PRACH time mask.....	97
6.3.4.2.2	SRS time mask.....	98
6.3.4.3	Slot / Sub frame boundary time mask.....	99
6.3.4.4	PUCCH / PUSCH / SRS time mask.....	99
6.3.4A	ON/OFF time mask for CA.....	101
6.3.4B	ON/OFF time mask for UL-MIMO.....	101
6.3.4D	ON/OFF time mask for ProSe.....	101
6.3.4D.1	General time mask for ProSe.....	101
6.3.4D.2	PSSS/SSSS time mask.....	102
6.3.4D.3	PSSS / SSSS / PSBCH time mask.....	103
6.3.4D.4	PSSCH / SRS time mask.....	104
6.3.5	Power Control.....	104
6.3.5.1	Absolute power tolerance.....	104
6.3.5.1.1	Minimum requirements.....	104
6.3.5.2	Relative Power tolerance.....	104
6.3.5.2.1	Minimum requirements.....	104
6.3.5.3	Aggregate power control tolerance.....	105
6.3.5.3.1	Minimum requirement.....	105
6.3.5A	Power control for CA.....	106
6.3.5A.1	Absolute power tolerance.....	106

6.3.5A.1.1	Minimum requirements	106
6.3.5A.2	Relative power tolerance	106
6.3.5A.2.1	Minimum requirements	106
6.3.5A.3	Aggregate power control tolerance	107
6.3.5A.3.1	Minimum requirements	107
6.3.5B	Power control for UL-MIMO	107
6.3.5D	Power Control for ProSe.....	107
6.3.5D.1	Absolute power tolerance.....	107
6.4	Void.....	108
6.5	Transmit signal quality	108
6.5.1	Frequency error.....	108
6.5.1A	Frequency error for CA.....	108
6.5.1B	Frequency error for UL-MIMO	108
6.5.1D	Frequency error for ProSe.....	108
6.5.2	Transmit modulation quality.....	108
6.5.2.1	Error Vector Magnitude	108
6.5.2.1.1	Minimum requirement.....	109
6.5.2.2	Carrier leakage	109
6.5.2.2.1	Minimum requirements	109
6.5.2.3	In-band emissions	109
6.5.2.3.1	Minimum requirements	110
6.5.2.4	EVM equalizer spectrum flatness	110
6.5.2.4.1	Minimum requirements	110
6.5.2A	Transmit modulation quality for CA.....	111
6.5.2A.1	Error Vector Magnitude	112
6.5.2A.2	Carrier leakage for CA	112
6.5.2A.2.1	Minimum requirements.....	112
6.5.2A.3	In-band emissions	112
6.5.2A.3.1	Minimum requirement for CA.....	112
6.5.2B	Transmit modulation quality for UL-MIMO	114
6.5.2B.1	Error Vector Magnitude	115
6.5.2B.2	Carrier leakage	115
6.5.2B.3	In-band emissions	115
6.5.2B.4	EVM equalizer spectrum flatness for UL-MIMO	115
6.5.2D	Transmit modulation quality for ProSe.....	115
6.5.2D.1	Error Vector Magnitude	115
6.5.2D.2	Carrier leakage	115
6.5.2D.3	In-band emissions	115
6.5.2D.4	EVM equalizer spectrum flatness for ProSe	116
6.6	Output RF spectrum emissions.....	116
6.6.1	Occupied bandwidth	116
6.6.1A	Occupied bandwidth for CA	116
6.6.1B	Occupied bandwidth for UL-MIMO.....	117
6.6.2	Out of band emission	117
6.6.2.1	Spectrum emission mask.....	117
6.6.2.1.1	Minimum requirement.....	117
6.6.2.1A	Spectrum emission mask for CA.....	118
6.6.2.2	Additional spectrum emission mask	118
6.6.2.2.1	Minimum requirement (network signalled value "NS_03", "NS_11", "NS_20", and "NS_21")..	118
6.6.2.2.2	Minimum requirement (network signalled value "NS_04")	119
6.6.2.2.3	Minimum requirement (network signalled value "NS_06" or "NS_07")	119
6.6.2.2A	Additional Spectrum Emission Mask for CA.....	120
6.6.2.2A.1	Minimum requirement (network signalled value "CA_NS_04").....	120
6.6.2.3	Adjacent Channel Leakage Ratio.....	121
6.6.2.3.1	Minimum requirement E-UTRA	121
6.6.2.3.1A	Void.....	122
6.6.2.3.1Aa	Void.....	122
6.6.2.3.2	Minimum requirements UTRA	122
6.6.2.3.2A	Minimum requirement UTRA for CA.....	122
6.6.2.3.3A	Minimum requirements for CA E-UTRA.....	124
6.6.2.4	Void.....	124
6.6.2.4.1	Void.....	124

6.6.2A	Void	124
6.6.2B	Out of band emission for UL-MIMO.....	125
6.6.3	Spurious emissions	125
6.6.3.1	Minimum requirements.....	125
6.6.3.1A	Minimum requirements for CA.....	125
6.6.3.2	Spurious emission band UE co-existence	126
6.6.3.2A	Spurious emission band UE co-existence for CA	131
6.6.3.3	Additional spurious emissions	137
6.6.3.3.1	Minimum requirement (network signalled value "NS_05")	137
6.6.3.3.2	Minimum requirement (network signalled value "NS_07").....	137
6.6.3.3.3	Minimum requirement (network signalled value "NS_08").....	138
6.6.3.3.4	Minimum requirement (network signalled value "NS_09").....	138
6.6.3.3.5	Minimum requirement (network signalled value "NS_12").....	138
6.6.3.3.6	Minimum requirement (network signalled value "NS_13").....	138
6.6.3.3.7	Minimum requirement (network signalled value "NS_14").....	139
6.6.3.3.8	Minimum requirement (network signalled value "NS_15").....	139
6.6.3.3.9	Minimum requirement (network signalled value "NS_16").....	139
6.6.3.3.10	Minimum requirement (network signalled value "NS_17").....	140
6.6.3.3.11	Minimum requirement (network signalled value "NS_18").....	140
6.6.3.3.12	Minimum requirement (network signalled value "NS_19").....	140
6.6.3.3.13	Minimum requirement (network signalled value "NS_11").....	140
6.6.3.3.14	Minimum requirement (network signalled value "NS_20").....	141
6.6.3.3.15	Minimum requirement (network signalled value "NS_21").....	141
6.6.3.3.16	Minimum requirement (network signalled value "NS_22").....	141
6.6.3.3.17	Minimum requirement (network signalled value "NS_23").....	142
6.6.3.3.18	Void.....	142
6.6.3.3.19	Minimum requirement (network signalled value "NS_04").....	142
6.6.3.3.20	Void.....	144
6.6.3.3.21	Void.....	144
6.6.3.3.22	Void.....	144
6.6.3.3.23	Void.....	144
6.6.3.3.24	Void.....	144
6.6.3.3.25	Void.....	144
6.6.3.3.26	Void.....	144
6.6.3.3.27	Void.....	144
6.6.3.3.28	Void.....	144
6.6.3.3.29	Void.....	144
6.6.3.3.30	Void.....	144
6.6.3.3.31	Void.....	144
6.6.3.3.32	Void.....	145
6.6.3.3.33	Void.....	145
6.6.3.3.34	Void.....	145
6.6.3.3.35	Minimum requirement (network signalled value "NS_56").....	145
6.6.3.3A	Additional spurious emissions for CA	145
6.6.3.3A.1	Minimum requirement for CA_1C (network signalled value "CA_NS_01").....	145
6.6.3.3A.2	Minimum requirement for CA_1C (network signalled value "CA_NS_02").....	146
6.6.3.3A.3	Minimum requirement for CA_1C (network signalled value "CA_NS_03").....	146
6.6.3.3A.4	Minimum requirement for CA_38C (network signalled value "CA_NS_05").....	146
6.6.3.3A.5	Minimum requirement for CA_7C (network signalled value "CA_NS_06").....	147
6.6.3.3A.6	Minimum requirement for CA_39C (network signalled value "CA_NS_07").....	147
6.6.3.3A.7	Minimum requirement for CA_42C (network signalled value "CA_NS_08").....	147
6.6.3.3A.8	Minimum requirement for CA_41C (network signalled value "CA_NS_04").....	148
6.6.3A	Void.....	148
6.6.3B	Spurious emission for UL-MIMO	148
6.6A	Void.....	149
6.6B	Void.....	149
6.7	Transmit intermodulation.....	149
6.7.1	Minimum requirement	149
6.7.1A	Minimum requirement for CA	149
6.7.1B	Minimum requirement for UL-MIMO.....	150
6.8	Void.....	150
6.8.1	Void.....	150

6.8A	Void.....	150
6.8B	Time alignment error for UL-MIMO	150
6.8B.1	Minimum Requirements	150
7	Receiver characteristics	150
7.1	General	150
7.2	Diversity characteristics	151
7.3	Reference sensitivity power level.....	151
7.3.1	Minimum requirements (QPSK).....	151
7.3.1A	Minimum requirements (QPSK) for CA.....	161
7.3.1B	Minimum requirements (QPSK) for UL-MIMO	174
7.3.1D	Minimum requirements (QPSK) for ProSe.....	174
7.3.1E	Minimum requirements (QPSK) for UE category 0	175
7.3.2	Void	176
7.4	Maximum input level	176
7.4.1	Minimum requirements.....	176
7.4.1A	Minimum requirements for CA	177
7.4.1B	Minimum requirements for UL-MIMO	178
7.4.1D	Minimum requirements for ProSe	178
7.4A	Void.....	179
7.4A.1	Void	179
7.5	Adjacent Channel Selectivity (ACS).....	179
7.5.1	Minimum requirements.....	179
7.5.1A	Minimum requirements for CA	180
7.5.1B	Minimum requirements for UL-MIMO	182
7.5.1D	Minimum requirements for ProSe	182
7.6	Blocking characteristics	183
7.6.1	In-band blocking	183
7.6.1.1	Minimum requirements.....	183
7.6.1.1A	Minimum requirements for CA.....	184
7.6.1.1D	Minimum requirements for ProSe.....	186
7.6.2	Out-of-band blocking.....	187
7.6.2.1	Minimum requirements.....	187
7.6.2.1A	Minimum requirements for CA.....	188
7.6.2.1D	Minimum requirements for ProSe.....	191
7.6.3	Narrow band blocking	191
7.6.3.1	Minimum requirements.....	192
7.6.3.1A	Minimum requirements for CA.....	192
7.6.3.1D	Minimum requirements for ProSe.....	193
7.6A	Void.....	194
7.6B	Blocking characteristics for UL-MIMO	194
7.7	Spurious response.....	194
7.7.1	Minimum requirements.....	194
7.7.1A	Minimum requirements for CA	195
7.7.1B	Minimum requirements for UL-MIMO	196
7.7.1D	Minimum requirements for ProSe	196
7.8	Intermodulation characteristics	197
7.8.1	Wide band intermodulation.....	197
7.8.1.1	Minimum requirements.....	197
7.8.1A	Minimum requirements for CA	197
7.8.1B	Minimum requirements for UL-MIMO	199
7.8.1D	Minimum requirements for ProSe	199
7.8.2	Void	200
7.9	Spurious emissions	200
7.9.1	Minimum requirements.....	200
7.9.1A	Minimum requirements.....	200
7.10	Receiver image	200
7.10.1	Void	200
7.10.1A	Minimum requirements for CA	200
8	Performance requirement	202
8.1	General	202

8.1.1	Receiver antenna capability	202
8.1.1.1	Simultaneous unicast and MBMS operations.....	203
8.1.1.2	Dual-antenna receiver capability in idle mode	203
8.1.2	Applicability of requirements	203
8.1.2.1	Applicability of requirements for different channel bandwidths.....	203
8.1.2.2	Definition of CA capability	203
8.1.2.2A	Definition of dual connectivity capability	204
8.1.2.3	Applicability and test rules for different CA configurations and bandwidth combination sets.....	205
8.1.2.3A	Applicability and test rules for different dual connectivity configuration and bandwidth combination set	207
8.1.2.3B	Applicability and test rules for different TDD-FDD CA configurations and bandwidth combination sets.....	208
8.1.2.4	Test coverage for different number of component carriers	209
8.1.2.5	Applicability of performance requirements for Type B receiver	210
8.1.3	UE category and UE DL category	210
8.2	Demodulation of PDSCH (Cell-Specific Reference Symbols)	210
8.2.1	FDD (Fixed Reference Channel)	210
8.2.1.1	Single-antenna port performance	210
8.2.1.1.1	Minimum Requirement	211
8.2.1.1.2	Void	214
8.2.1.1.3	Void	214
8.2.1.1.4	Minimum Requirement 1 PRB allocation in presence of MBSFN.....	214
8.2.1.2	Transmit diversity performance	215
8.2.1.2.1	Minimum Requirement 2 Tx Antenna Port	215
8.2.1.2.2	Minimum Requirement 4 Tx Antenna Port	215
8.2.1.2.3	Minimum Requirement 2 Tx Antenna Port (demodulation subframe overlaps with aggressor cell ABS)	216
8.2.1.2.3A	Minimum Requirement 2 Tx Antenna Ports (demodulation subframe overlaps with aggressor cell ABS and CRS assistance information are configured)	218
8.2.1.2.4	Enhanced Performance Requirement Type A - 2 Tx Antenna Ports with TM3 interference model	220
8.2.1.2.5	Enhanced Performance Requirement Type B - 2 Tx Antenna Ports with TM2 interference model	222
8.2.1.2.6	Enhanced Performance Requirement Type B - 2 Tx Antenna Ports with TM9 interference model	223
8.2.1.3	Open-loop spatial multiplexing performance.....	224
8.2.1.3.1	Minimum Requirement 2 Tx Antenna Port	224
8.2.1.3.1B	Enhanced Performance Requirement Type C –2Tx Antenna Ports	227
8.2.1.3.1C	Enhanced Performance Requirement Type C - 2 Tx Antenna Ports with TM1 interference	228
8.2.1.3.2	Minimum Requirement 4 Tx Antenna Port	229
8.2.1.3.3	Minimum Requirement 2 Tx Antenna Port (demodulation subframe overlaps with aggressor cell ABS)	229
8.2.1.3.4	Minimum Requirement 2 Tx Antenna Port (demodulation subframe overlaps with aggressor cell ABS and CRS assistance information are configured)	233
8.2.1.4	Closed-loop spatial multiplexing performance	235
8.2.1.4.1	Minimum Requirement Single-Layer Spatial Multiplexing 2 Tx Antenna Port.....	235
8.2.1.4.1A	Minimum Requirement Single-Layer Spatial Multiplexing 4 Tx Antenna Port.....	236
8.2.1.4.1B	Enhanced Performance Requirement Type A - Single-Layer Spatial Multiplexing 2 Tx Antenna Port with TM4 interference model	236
8.2.1.4.1C	Minimum Requirement Single-Layer Spatial Multiplexing 2 Tx Antenna Ports (demodulation subframe overlaps with aggressor cell ABS and CRS assistance information are configured).....	238
8.2.1.4.1D	Enhanced Performance Requirement Type B - Single-layer Spatial Multiplexing 2 Tx Antenna Port with TM4 interference model	240
8.2.1.4.2	Minimum Requirement Multi-Layer Spatial Multiplexing 2 Tx Antenna Port	242
8.2.1.4.2A	Enhanced Performance Requirement Type C – Multi-layer Spatial Multiplexing 2Tx Antenna Ports.....	242
8.2.1.4.3	Minimum Requirement Multi-Layer Spatial Multiplexing 4 Tx Antenna Port	243
8.2.1.4.3A	Minimum Requirement Multi-Layer Spatial Multiplexing 4 Tx Antenna Port for dual connectivity	246
8.2.1.5	MU-MIMO.....	248
8.2.1.6	[Control channel performance: D-BCH and PCH]	248
8.2.1.7	Carrier aggregation with power imbalance	248

8.2.1.7.1	Minimum Requirement	248
8.2.1.8	Intra-band non-contiguous carrier aggregation with timing offset.....	249
8.2.1.8.1	Minimum Requirement	249
8.2.2	TDD (Fixed Reference Channel)	250
8.2.2.1	Single-antenna port performance	250
8.2.2.1.1	Minimum Requirement	250
8.2.2.1.2	Void	254
8.2.2.1.3	Void	254
8.2.2.1.4	Minimum Requirement 1 PRB allocation in presence of MBSFN.....	254
8.2.2.2	Transmit diversity performance	255
8.2.2.2.1	Minimum Requirement 2 Tx Antenna Port	255
8.2.2.2.2	Minimum Requirement 4 Tx Antenna Port	255
8.2.2.2.3	Minimum Requirement 2 Tx Antenna Port (demodulation subframe overlaps with aggressor cell ABS)	256
8.2.2.2.3A	Minimum Requirement 2 Tx Antenna Ports (demodulation subframe overlaps with aggressor cell ABS and CRS assistance information are configured)	258
8.2.2.2.4	Enhanced Performance Requirement Type A – 2 Tx Antenna Ports with TM3 interference model	260
8.2.2.2.5	Minimum Requirement 2 Tx Antenna Port (when <i>EIMTA-MainConfigServCell-r12</i> is configured)	262
8.2.2.2.6	Enhanced Performance Requirement Type B - 2 Tx Antenna Ports with TM2 interference model	262
8.2.2.2.7	Enhanced Performance Requirement Type B - 2 Tx Antenna Ports with TM9 interference model	264
8.2.2.3	Open-loop spatial multiplexing performance.....	265
8.2.2.3.1	Minimum Requirement 2 Tx Antenna Port	265
8.2.2.3.1A	Soft buffer management test.....	267
8.2.2.3.1B	Enhanced Performance Requirement Type C - 2Tx Antenna Ports.....	268
8.2.2.3.1C	Enhanced Performance Requirement Type C - 2 Tx Antenna Ports with TM1 interference	268
8.2.2.3.2	Minimum Requirement 4 Tx Antenna Port	269
8.2.2.3.3	Minimum Requirement 2Tx antenna port (demodulation subframe overlaps with aggressor cell ABS).....	270
8.2.2.3.4	Minimum Requirement 2 Tx Antenna Port (demodulation subframe overlaps with aggressor cell ABS and CRS assistance information are configured)	274
8.2.2.4	Closed-loop spatial multiplexing performance	276
8.2.2.4.1	Minimum Requirement Single-Layer Spatial Multiplexing 2 Tx Antenna Port.....	276
8.2.2.4.1A	Minimum Requirement Single-Layer Spatial Multiplexing 4 Tx Antenna Port.....	277
8.2.2.4.1B	Enhanced Performance Requirement Type A – Single-Layer Spatial Multiplexing 2 Tx Antenna Port with TM4 interference model	277
8.2.2.4.1C	Minimum Requirement Single-Layer Spatial Multiplexing 2 Tx Antenna Ports (demodulation subframe overlaps with aggressor cell ABS and CRS assistance information are configured).....	279
8.2.2.4.1D	Enhanced Performance Requirement Type B - Single-layer Spatial Multiplexing 2 Tx Antenna Port with TM4 interference model	281
8.2.2.4.2	Minimum Requirement Multi-Layer Spatial Multiplexing 2 Tx Antenna Port	283
8.2.2.4.2A	Enhanced Performance Requirement Type C Multi-Layer Spatial Multiplexing 2 Tx Antenna Port	284
8.2.2.4.3	Minimum Requirement Multi-Layer Spatial Multiplexing 4 Tx Antenna Port	284
8.2.2.4.3A	Minimum Requirement Multi-Layer Spatial Multiplexing 4 Tx Antenna Port for dual connectivity	287
8.2.2.4.4	Void	289
8.2.2.5	MU-MIMO.....	289
8.2.2.6	[Control channel performance: D-BCH and PCH]	289
8.2.2.7	Carrier aggregation with power imbalance	289
8.2.2.7.1	Minimum Requirement	289
8.2.2.8	Intra-band contiguous carrier aggregation with minimum channel spacing.....	290
8.2.2.8.1	Minimum Requirement	290
8.2.3	TDD FDD CA (Fixed Reference Channel).....	291
8.2.3.1	Single-antenna port performance	292
8.2.3.1.1	Minimum Requirement for FDD PCell	292
8.2.3.1.2	Minimum Requirement for TDD PCell	293
8.2.3.2	Open-loop spatial multiplexing performance 2Tx Antenna port.....	295
8.2.3.2.1	Minimum Requirement for FDD PCell	295

8.2.3.2.1A	Soft buffer management test for FDD PCell	297
8.2.3.2.2	Minimum Requirement for TDD PCell	297
8.2.3.2.2A	Soft buffer management test for TDD PCell	299
8.2.3.3	Closed-loop spatial multiplexing performance 4Tx Antenna Port	300
8.2.3.3.1	Minimum Requirement for FDD PCell	300
8.2.3.3.2	Minimum Requirement for TDD PCell	302
8.3	Demodulation of PDSCH (User-Specific Reference Symbols).....	304
8.3.1	FDD	304
8.3.1.1	Single-layer Spatial Multiplexing	305
8.3.1.1A	Enhanced Performance Requirement Type A – Single-layer Spatial Multiplexing with TM9 interference model.....	307
8.3.1.1B	Single-layer Spatial Multiplexing (demodulation subframe overlaps with aggressor cell ABS and CRS assistance information are configured)	309
8.3.1.1C	Enhanced Performance Requirement Type B – Single-layer Spatial Multiplexing with TM9 interference model.....	311
8.3.1.1D	Enhanced Performance Requirement Type B – Single-layer Spatial Multiplexing with CRS interference model.....	313
8.3.1.1E	Enhanced Performance Requirement Type B – Single-layer Spatial Multiplexing with TM3 interference model.....	314
8.3.1.1F	Enhanced Performance Requirement Type B – Single-layer Spatial Multiplexing with TM10 serving cell configuration and TM9 interference model	315
8.3.1.2	Dual-Layer Spatial Multiplexing	317
8.3.1.2A	Enhanced Performance Requirement Type C - Dual-Layer Spatial Multiplexing	318
8.3.1.3	Performance requirements for DCI format 2D and non Quasi Co-located Antenna Ports	319
8.3.1.3.1	Minimum requirement with Same Cell ID (with single NZP CSI-RS resource).....	319
8.3.1.3.2	Minimum requirements with Same Cell ID (with multiple NZP CSI-RS resources).....	321
8.3.1.3.3	Minimum requirement with Different Cell ID and Colliding CRS (with single NZP CSI-RS resource)	323
8.3.2	TDD	325
8.3.2.1	Single-layer Spatial Multiplexing	325
8.3.2.1A	Single-layer Spatial Multiplexing (with multiple CSI-RS configurations)	327
8.3.2.1B	Enhanced Performance Requirement Type A – Single-layer Spatial Multiplexing with TM9 interference model.....	329
8.3.2.1C	Single-layer Spatial Multiplexing (demodulation subframe overlaps with aggressor cell ABS and CRS assistance information are configured)	331
8.3.2.1D	Enhanced Performance Requirement Type B – Single-layer Spatial Multiplexing with TM9 interference.....	333
8.3.2.1E	Enhanced Performance Requirement Type B – Single-layer Spatial Multiplexing with CRS interference model.....	335
8.3.2.1F	Enhanced Performance Requirement Type B – Single-layer Spatial Multiplexing with TM3 interference.....	337
8.3.2.1G	Enhanced Performance Requirement Type B – Single-layer Spatial Multiplexing with TM10 serving cell configuration and TM9 interference model	338
8.3.2.2	Dual-Layer Spatial Multiplexing	340
8.3.2.2A	Enhanced Performance Requirement Type C - Dual-Layer Spatial Multiplexing	341
8.3.2.3	Dual-Layer Spatial Multiplexing (with multiple CSI-RS configurations)	342
8.3.2.4	Performance requirements for DCI format 2D and non Quasi Co-located Antenna Ports	343
8.3.2.4.1	Minimum requirement with Same Cell ID (with single NZP CSI-RS resource).....	343
8.3.2.4.2	Minimum requirements with Same Cell ID (with multiple NZP CSI-RS resources).....	345
8.3.2.4.3	Minimum requirement with Different Cell ID and Colliding CRS (with single NZP CSI-RS resource)	347
8.4	Demodulation of PDCCH/PCFICH	349
8.4.1	FDD	349
8.4.1.1	Single-antenna port performance	349
8.4.1.2	Transmit diversity performance	349
8.4.1.2.1	Minimum Requirement 2 Tx Antenna Port	349
8.4.1.2.2	Minimum Requirement 4 Tx Antenna Port	350
8.4.1.2.3	Minimum Requirement 2 Tx Antenna Port (demodulation subframe overlaps with aggressor cell ABS)	350
8.4.1.2.4	Minimum Requirement 2 Tx Antenna Port (demodulation subframe overlaps with aggressor cell ABS and CRS assistance information are configured)	354
8.4.2	TDD.....	358
8.4.2.1	Single-antenna port performance	359

8.4.2.2	Transmit diversity performance	359
8.4.2.2.1	Minimum Requirement 2 Tx Antenna Port	359
8.4.2.2.2	Minimum Requirement 4 Tx Antenna Port	360
8.4.2.2.3	Minimum Requirement 2 Tx Antenna Port (demodulation subframe overlaps with aggressor cell ABS)	360
8.4.2.2.4	Minimum Requirement 2 Tx Antenna Port (demodulation subframe overlaps with aggressor cell ABS and CRS assistance information are configured)	364
8.5	Demodulation of PHICH	368
8.5.1	FDD	368
8.5.1.1	Single-antenna port performance	368
8.5.1.2	Transmit diversity performance	369
8.5.1.2.1	Minimum Requirement 2 Tx Antenna Port	369
8.5.1.2.2	Minimum Requirement 4 Tx Antenna Port	369
8.5.1.2.3	Minimum Requirement 2 Tx Antenna Port (demodulation subframe overlaps with aggressor cell ABS)	369
8.5.1.2.4	Minimum Requirement 2 Tx Antenna Port (demodulation subframe overlaps with aggressor cell ABS and CRS assistance information are configured)	371
8.5.2	TDD	373
8.5.2.1	Single-antenna port performance	374
8.5.2.2	Transmit diversity performance	374
8.5.2.2.1	Minimum Requirement 2 Tx Antenna Port	374
8.5.2.2.2	Minimum Requirement 4 Tx Antenna Port	375
8.5.2.2.3	Minimum Requirement 2 Tx Antenna Port (demodulation subframe overlaps with aggressor cell ABS)	375
8.5.2.2.4	Minimum Requirement 2 Tx Antenna Port (demodulation subframe overlaps with aggressor cell ABS and CRS assistance information are configured)	377
8.6	Demodulation of PBCH	379
8.6.1	FDD	379
8.6.1.1	Single-antenna port performance	379
8.6.1.2	Transmit diversity performance	380
8.6.1.2.1	Minimum Requirement 2 Tx Antenna Port	380
8.6.1.2.2	Minimum Requirement 4 Tx Antenna Port	380
8.6.1.2.3	Minimum Requirement 2 Tx Antenna Port under Time Domain Measurement Resource Restriction with CRS Assistance Information	380
8.6.2	TDD	382
8.6.2.1	Single-antenna port performance	382
8.6.2.2	Transmit diversity performance	382
8.6.2.2.1	Minimum Requirement 2 Tx Antenna Port	382
8.6.2.2.2	Minimum Requirement 4 Tx Antenna Port	382
8.6.2.2.3	Minimum Requirement 2 Tx Antenna Port under Time Domain Measurement Resource Restriction with CRS Assistance Information	383
8.7	Sustained downlink data rate provided by lower layers	384
8.7.1	FDD (single carrier and CA)	384
8.7.2	TDD (single carrier and CA)	389
8.7.3	FDD (EPDCCH scheduling)	392
8.7.4	TDD (EPDCCH scheduling)	393
8.7.5	TDD FDD CA	395
8.7.5.1	Minimum Requirement FDD PCell	396
8.7.5.2	Minimum Requirement TDD PCell	398
8.7.6	FDD (DC)	399
8.7.7	TDD (DC)	402
8.8	Demodulation of EPDCCH	405
8.8.1	Distributed Transmission	405
8.8.1.1	FDD	405
8.8.1.1.1	Void	406
8.8.1.2	TDD	406
8.8.1.2.1	Void	407
8.8.2	Localized Transmission with TM9	407
8.8.2.1	FDD	407
8.8.2.1.1	Void	408
8.8.2.1.2	Void	408
8.8.2.2	TDD	408

8.8.2.2.1	Void.....	410
8.8.2.2.2	Void.....	410
8.8.3	Localized transmission with TM10 Type B quasi co-location type.....	410
8.8.3.1	FDD.....	410
8.8.3.2	TDD.....	412
8.9	Demodulation (single receiver antenna).....	414
8.9.1	PDSCH.....	414
8.9.1.1	FDD and half-duplex FDD (Fixed Reference Channel).....	414
8.9.1.1.1	Transmit diversity performance (Cell-Specific Reference Symbols).....	415
8.9.1.1.2	Closed-loop spatial multiplexing performance (Cell-Specific Reference Symbols).....	415
8.9.1.1.3	Closed-loop spatial multiplexing performance (User-Specific Reference Symbols).....	416
8.9.1.2	TDD (Fixed Reference Channel).....	417
8.9.1.2.1	Transmit diversity performance (Cell-Specific Reference Symbols).....	418
8.9.1.2.2	Closed-loop spatial multiplexing performance (Cell-Specific Reference Symbols).....	419
8.9.1.2.3	Closed-loop spatial multiplexing performance (User-Specific Reference Symbols).....	419
8.9.2	PHICH.....	421
8.9.2.1	FDD and half-duplex FDD.....	421
8.9.2.1.1	Transmit diversity performance.....	421
8.9.2.2	TDD.....	421
8.9.2.2.1	Transmit diversity performance.....	421
8.9.3	PBCH.....	421
8.9.3.1	FDD and half-duplex FDD.....	421
8.9.3.1.1	Transmit diversity performance.....	421
8.9.3.2	TDD.....	422
8.9.3.2.1	Transmit diversity performance.....	422
9	Reporting of Channel State Information.....	422
9.1	General.....	422
9.1.1	Applicability of requirements.....	422
9.1.1.1	Applicability of requirements for different channel bandwidths.....	422
9.1.1.2	Applicability and test rules for different CA configurations and bandwidth combination sets.....	422
9.1.1.2A	Applicability and test rules for different TDD-FDD CA configurations and bandwidth combination sets.....	423
9.1.1.3	Test coverage for different number of component carriers.....	424
9.2	CQI reporting definition under AWGN conditions.....	424
9.2.1	Minimum requirement PUCCH 1-0 (Cell-Specific Reference Symbols).....	425
9.2.1.1	FDD.....	425
9.2.1.2	TDD.....	426
9.2.1.3	FDD (CSI measurements in case two CSI subframe sets are configured).....	427
9.2.1.4	TDD (CSI measurements in case two CSI subframe sets are configured).....	429
9.2.1.5	FDD (CSI measurements in case two CSI subframe sets are configured and with CRS assistance information).....	431
9.2.1.6	TDD (CSI measurements in case two CSI subframe sets are configured and with CRS assistance information).....	433
9.2.1.7	FDD (Modulation and TBS index Table 2 and 4-bit CQI Table 2 are used).....	435
9.2.1.8	TDD (Modulation and TBS index Table 2 and 4-bit CQI Table 2 are used).....	436
9.2.2	Minimum requirement PUCCH 1-1 (Cell-Specific Reference Symbols).....	436
9.2.2.1	FDD.....	436
9.2.2.2	TDD.....	437
9.2.3	Minimum requirement PUCCH 1-1 (CSI Reference Symbols).....	438
9.2.3.1	FDD.....	438
9.2.3.2	TDD.....	439
9.2.4	Minimum requirement PUCCH 1-1 (With Single CSI Process).....	440
9.2.4.1	FDD.....	440
9.2.4.2	TDD.....	443
9.2.5	Minimum requirement PUCCH 1-1 (when <i>csi-SubframeSet-r12</i> and <i>EIMTA-MainConfigServCell-r12</i> are configured).....	445
9.3	CQI reporting under fading conditions.....	447
9.3.1	Frequency-selective scheduling mode.....	447
9.3.1.1	Minimum requirement PUSCH 3-0 (Cell-Specific Reference Symbols).....	447
9.3.1.1.1	FDD.....	447
9.3.1.1.2	TDD.....	448

9.3.1.1.3	FDD (CSI measurements in case two CSI subframe sets are configured and with CRS assistance information)	449
9.3.1.1.4	TDD (CSI measurements in case two CSI subframe sets are configured and with CRS assistance information)	452
9.3.1.1.5	TDD (when <i>csi-SubframeSet-r12</i> is configured)	454
9.3.1.2	Minimum requirement PUSCH 3-1 (CSI Reference Symbol)	456
9.3.1.2.1	FDD	456
9.3.1.2.2	TDD	457
9.3.1.2.3	FDD (Modulation and TBS index Table 2 and 4-bit CQI Table 2 are used)	459
9.3.1.2.4	TDD (Modulation and TBS index Table 2 and 4-bit CQI Table 2 are used)	460
9.3.1.2.5	Void	461
9.3.1.2.6	TDD (when <i>csi-SubframeSet-r12</i> is configured with one CSI process)	461
9.3.2	Frequency non-selective scheduling mode	464
9.3.2.1	Minimum requirement PUCCH 1-0 (Cell-Specific Reference Symbol)	464
9.3.2.1.1	FDD	464
9.3.2.1.2	TDD	466
9.3.2.2	Minimum requirement PUCCH 1-1 (CSI Reference Symbol)	468
9.3.2.2.1	FDD	468
9.3.2.2.2	TDD	469
9.3.3	Frequency-selective interference	471
9.3.3.1	Minimum requirement PUSCH 3-0 (Cell-Specific Reference Symbol)	471
9.3.3.1.1	FDD	471
9.3.3.1.2	TDD	472
9.3.3.2	Void	473
9.3.3.2.1	Void	473
9.3.3.2.2	Void	473
9.3.4	UE-selected subband CQI	473
9.3.4.1	Minimum requirement PUSCH 2-0 (Cell-Specific Reference Symbols)	473
9.3.4.1.1	FDD	473
9.3.4.1.2	TDD	474
9.3.4.2	Minimum requirement PUCCH 2-0 (Cell-Specific Reference Symbols)	475
9.3.4.2.1	FDD	475
9.3.4.2.2	TDD	477
9.3.5	Additional requirements for enhanced receiver Type A	479
9.3.5.1	Minimum requirement PUCCH 1-0 (Cell-Specific Reference Symbol)	479
9.3.5.1.1	FDD	479
9.3.5.1.2	TDD	480
9.3.5.2	Minimum requirement PUCCH 1-1 (CSI Reference Symbol)	483
9.3.5.2.1	FDD	483
9.3.5.2.2	TDD	485
9.3.6	Minimum requirement (With multiple CSI processes)	487
9.3.6.1	FDD	487
9.3.6.2	TDD	491
9.3.7	Minimum requirement PUSCH 3-2	494
9.3.7.1	FDD	494
9.3.7.2	TDD	495
9.3.8	Additional requirements for enhanced receiver Type B	497
9.3.8.1	Minimum requirement PUCCH 1-1 (Cell-Specific Reference Symbols)	497
9.3.8.1.1	FDD	497
9.3.8.1.2	TDD	498
9.3.8.2	Minimum requirement PUCCH 1-1 (CSI Reference Symbols)	500
9.3.8.2.1	FDD	500
9.3.8.2.2	TDD	502
9.3.8.3	Minimum requirement with CSI process	504
9.3.8.3.1	FDD	504
9.3.8.3.2	TDD	506
9.4	Reporting of Precoding Matrix Indicator (PMI)	508
9.4.1	Single PMI	509
9.4.1.1	Minimum requirement PUSCH 3-1 (Cell-Specific Reference Symbols)	509
9.4.1.1.1	FDD	509
9.4.1.1.2	TDD	509
9.4.1.2	Minimum requirement PUCCH 2-1 (Cell-Specific Reference Symbols)	510

9.4.1.2.1	FDD	510
9.4.1.2.2	TDD	512
9.4.1.3	Minimum requirement PUSCH 3-1 (CSI Reference Symbol)	513
9.4.1.3.1	FDD	513
9.4.1.3.2	TDD	514
9.4.1.4	Minimum requirement PUCCH 1-1 (CSI Reference Symbol)	516
9.4.1.4.1	FDD (with 4Tx enhanced codebook)	516
9.4.1.4.2	TDD (with 4Tx enhanced codebook)	518
9.4.1a	Void	520
9.4.1a.1	Void	520
9.4.1a.1.1	Void	520
9.4.1a.1.2	Void	520
9.4.2	Multiple PMI	520
9.4.2.1	Minimum requirement PUSCH 1-2 (Cell-Specific Reference Symbols)	520
9.4.2.1.1	FDD	520
9.4.2.1.2	TDD	521
9.4.2.2	Minimum requirement PUSCH 2-2 (Cell-Specific Reference Symbols)	522
9.4.2.2.1	FDD	522
9.4.2.2.2	TDD	523
9.4.2.3	Minimum requirement PUSCH 1-2 (CSI Reference Symbol)	524
9.4.2.3.1	FDD	524
9.4.2.3.2	TDD	526
9.4.2.3.3	FDD (with 4Tx enhanced codebook)	528
9.4.2.3.4	TDD (with 4Tx enhanced codebook)	530
9.4.3	Void	532
9.4.3.1	Void	532
9.4.3.1.1	Void	532
9.4.3.1.2	Void	532
9.5	Reporting of Rank Indicator (RI)	532
9.5.1	Minimum requirement (Cell-Specific Reference Symbols)	532
9.5.1.1	FDD	532
9.5.1.2	TDD	533
9.5.2	Minimum requirement (CSI Reference Symbols)	534
9.5.2.1	FDD	534
9.5.2.2	TDD	536
9.5.3	Minimum requirement (CSI measurements in case two CSI subframe sets are configured)	538
9.5.3.1	FDD	538
9.5.3.2	TDD	540
9.5.4	Minimum requirement (CSI measurements in case two CSI subframe sets are configured and CRS assistance information are configured)	542
9.5.4.1	FDD	542
9.5.4.2	TDD	544
9.5.5	Minimum requirement (with CSI process)	546
9.5.5.1	FDD	547
9.5.5.2	TDD	549
9.6	Additional requirements for carrier aggregation	551
9.6.1	Periodic reporting on multiple cells (Cell-Specific Reference Symbols)	551
9.6.1.1	FDD	551
9.6.1.2	TDD	553
9.6.1.3	TDD-FDD CA with FDD PCell	555
9.6.1.4	TDD-FDD CA with TDD PCell	557
9.7	CSI reporting (Single receiver antenna)	559
9.7.1	CQI reporting definition under AWGN conditions	559
9.7.1.1	FDD and half-duplex FDD	559
9.7.1.2	TDD	560
9.7.2	CQI reporting under fading conditions	561
9.7.2.1	FDD and half-duplex FDD	561
9.7.2.2	TDD	562
10	Performance requirement (MBMS)	563
10.1	FDD (Fixed Reference Channel)	563
10.1.1	Minimum requirement	564

10.2	TDD (Fixed Reference Channel).....	564
10.2.1	Minimum requirement	565
11	Performance requirement (ProSe Direct Discovery).....	565
11.1	General	566
11.1.1	Applicability of requirements	566
11.1.2	Reference DRX configuration	566
11.2	Demodulation of PSDCH (single link performance).....	566
11.2.1	FDD	566
11.2.2	TDD.....	567
11.3	Power imbalance performance with two links.....	568
11.3.1	FDD	568
11.3.2	TDD.....	569
11.4	Multiple timing reference test	570
11.4.1	FDD	571
11.5	Maximum Sidelink processes test	572
11.5.1	FDD	572
11.5.2	TDD.....	573
12	Performance requirement (ProSe Direct Communication)	575
12.1	General	575
12.1.1	Applicability of requirements	575
12.1.2	Reference DRX configuration	575
12.2	Demodulation of PSSCH.....	575
12.2.1	FDD	575
12.3	Demodulation of PSCCH.....	576
12.3.1	FDD	577
12.4	Demodulation of PSBCH.....	578
12.4.1	FDD	578
12.5	Power imbalance performance with two links.....	578
12.5.1	FDD	578
12.6	Multiple timing reference test	580
12.6.1	FDD	580
12.7	Maximum Sidelink processes test	582
12.7.1	FDD	582
12.8	Sustained downlink data rate with active Sidelink.....	583
Annex A (normative): Measurement channels.....		586
A.1	General	586
A.2	UL reference measurement channels	586
A.2.1	General	586
A.2.1.1	Applicability and common parameters	586
A.2.1.2	Determination of payload size	586
A.2.1.3	Overview of UL reference measurement channels.....	587
A.2.2	Reference measurement channels for FDD.....	596
A.2.2.1	Full RB allocation.....	596
A.2.2.1.1	QPSK	596
A.2.2.1.2	16-QAM.....	597
A.2.2.1.3	64-QAM.....	597
A.2.2.2	Partial RB allocation.....	597
A.2.2.2.1	QPSK	598
A.2.2.2.2	16-QAM.....	600
A.2.2.2.3	64-QAM.....	600
A.2.2.3	Void	601
A.2.3	Reference measurement channels for TDD.....	601
A.2.3.1	Full RB allocation.....	601
A.2.3.1.1	QPSK	601
A.2.3.1.2	16-QAM.....	602
A.2.3.1.3	64-QAM.....	603
A.2.3.2	Partial RB allocation.....	603
A.2.3.2.1	QPSK	604

A.2.3.2.2	16-QAM	606
A.2.3.2.3	64-QAM	607
A.2.3.3	Void	607
A.3	DL reference measurement channels	607
A.3.1	General	607
A.3.1.1	Overview of DL reference measurement channels	607
A.3.2	Reference measurement channel for receiver characteristics	620
A.3.3	Reference measurement channels for PDSCH performance requirements (FDD)	633
A.3.3.1	Single-antenna transmission (Common Reference Symbols)	633
A.3.3.2	Multi-antenna transmission (Common Reference Symbols)	638
A.3.3.2.1	Two antenna ports	638
A.3.3.2.2	Four antenna ports	640
A.3.3.3	Reference Measurement Channel for UE-Specific Reference Symbols	640
A.3.3.3.0	Two antenna ports (no CSI-RS)	640
A.3.3.3.1	Two antenna port (CSI-RS)	641
A.3.3.3.2	Four antenna ports (CSI-RS)	643
A.3.4	Reference measurement channels for PDSCH performance requirements (TDD)	648
A.3.4.1	Single-antenna transmission (Common Reference Symbols)	648
A.3.4.2	Multi-antenna transmission (Common Reference Signals)	656
A.3.4.2.1	Two antenna ports	656
A.3.4.2.2	Four antenna ports	661
A.3.4.3	Reference Measurement Channels for UE-Specific Reference Symbols	662
A.3.4.3.1	Single antenna port (Cell Specific)	662
A.3.4.3.2	Two antenna ports (Cell Specific)	662
A.3.4.3.3	Two antenna ports (CSI-RS)	664
A.3.4.3.4	Four antenna ports (CSI-RS)	666
A.3.4.3.5	Eight antenna ports (CSI-RS)	670
A.3.5	Reference measurement channels for PDCCH/PCFICH performance requirements	673
A.3.5.1	FDD	673
A.3.5.2	TDD	673
A.3.6	Reference measurement channels for PHICH performance requirements	673
A.3.7	Reference measurement channels for PBCH performance requirements	674
A.3.8	Reference measurement channels for MBMS performance requirements	674
A.3.8.1	FDD	674
A.3.8.2	TDD	676
A.3.9	Reference measurement channels for sustained downlink data rate provided by lower layers	678
A.3.9.1	FDD	678
A.3.9.2	TDD	681
A.3.9.3	FDD (EPDCCH scheduling)	684
A.3.9.4	TDD (EPDCCH scheduling)	685
A.3.10	Reference Measurement Channels for EPDCCH performance requirements	686
A.3.10.1	FDD	686
A.3.10.2	TDD	686
A.4	CSI reference measurement channels	686
A.5	OFDMA Channel Noise Generator (OCNG)	696
A.5.1	OCNG Patterns for FDD	696
A.5.1.1	OCNG FDD pattern 1: One sided dynamic OCNG FDD pattern	696
A.5.1.2	OCNG FDD pattern 2: Two sided dynamic OCNG FDD pattern	697
A.5.1.3	OCNG FDD pattern 3: 49 RB OCNG allocation with MBSFN in 10 MHz	697
A.5.1.4	OCNG FDD pattern 4: One sided dynamic OCNG FDD pattern for MBMS transmission	698
A.5.1.5	OCNG FDD pattern 5: One sided dynamic 16QAM modulated OCNG FDD pattern	698
A.5.1.6	OCNG FDD pattern 6: dynamic OCNG FDD pattern when user data is in 2 non-contiguous blocks	699
A.5.1.8	OCNG FDD pattern 8: Dynamic OCNG FDD pattern for TM10 transmission	700
A.5.2	OCNG Patterns for TDD	701
A.5.2.1	OCNG TDD pattern 1: One sided dynamic OCNG TDD pattern	701
A.5.2.2	OCNG TDD pattern 2: Two sided dynamic OCNG TDD pattern	702
A.5.2.3	OCNG TDD pattern 3: 49 RB OCNG allocation with MBSFN in 10 MHz	703
A.5.2.4	OCNG TDD pattern 4: One sided dynamic OCNG TDD pattern for MBMS transmission	703
A.5.2.5	OCNG TDD pattern 5: One sided dynamic 16QAM modulated OCNG TDD pattern	704
A.5.2.6	OCNG TDD pattern 6: dynamic OCNG TDD pattern when user data is in 2 non-contiguous blocks	705

A.5.2.8	OCNG TDD pattern 8: Dynamic OCNG TDD pattern for TM10 transmission	706
A.6	Sidelink reference measurement channels.....	707
A.6.1	General	707
A.6.1.1	Overview of ProSe reference measurement channels	707
A.6.2	Reference measurement channel for receiver characteristics	708
A.6.4	Reference measurement channels for PSSCH performance requirements.....	711
A.6.5	Reference measurement channels for PSSCH performance requirements	712
A.6.6	Reference measurement channels for PSBCH performance requirements.....	712
A.7	Sidelink reference resource pool configurations	713
A.7.1	Reference resource pool configurations for ProSe Direct Discovery demodulation tests	713
A.7.1.1	FDD	713
A.7.1.2	TDD.....	715
A.7.2	Reference resource pool configurations for ProSe Direct Communication demodulation tests.....	717
A.7.2.1	FDD	717
Annex B (normative):	Propagation conditions.....	723
B.1	Static propagation condition.....	723
B.2	Multi-path fading propagation conditions	723
B.2.1	Delay profiles	723
B.2.2	Combinations of channel model parameters	724
B.2.3	MIMO Channel Correlation Matrices	725
B.2.3.1	Definition of MIMO Correlation Matrices	725
B.2.3.2	MIMO Correlation Matrices at High, Medium and Low Level.....	726
B.2.3A	MIMO Channel Correlation Matrices using cross polarized antennas	728
B.2.3A.1	Definition of MIMO Correlation Matrices using cross polarized antennas	729
B.2.3A.2	Spatial Correlation Matrices using cross polarized antennas at eNB and UE sides.....	729
B.2.3A.2.1	Spatial Correlation Matrices at eNB side	729
B.2.3A.2.2	Spatial Correlation Matrices at UE side	730
B.2.3A.4	Beam steering approach.....	731
B.2.4	Propagation conditions for CQI tests.....	732
B.2.4.1	Propagation conditions for CQI tests with multiple CSI processes.....	732
B.2.5	Void.....	732
B.2.6	MBSFN Propagation Channel Profile	732
B.3	High speed train scenario	733
B.4	Beamforming Model	734
B.4.1	Single-layer random beamforming (Antenna port 5, 7, or 8)	734
B.4.2	Dual-layer random beamforming (antenna ports 7 and 8).....	735
B.4.3	Generic beamforming model (antenna ports 7-14).....	735
B.4.4	Random beamforming for EPDCCH distributed transmission (Antenna port 107 and 109).....	736
B.4.5	Random beamforming for EPDCCH localized transmission (Antenna port 107, 108, 109 or 110).....	736
B.5	Interference models for enhanced performance requirements Type-A	737
B.5.1	Dominant interferer proportion	737
B.5.2	Transmission mode 3 interference model.....	737
B.5.3	Transmission mode 4 interference model.....	738
B.5.4	Transmission mode 9 interference model.....	738
B.6	Interference models for enhanced performance requirements Type-B	738
B.6.1	Transmission mode 2 interference model.....	738
B.6.2	Transmission mode 3 interference model.....	739
B.6.3	Transmission mode 4 interference model.....	739
B.6.4	Transmission mode 9 interference model.....	740
B.6.5	CRS interference model	740
B.6.6	Random interference model	740
Annex C (normative):	Downlink Physical Channels.....	742
C.1	General	742
C.2	Set-up	742

C.3	Connection	742
C.3.1	Measurement of Receiver Characteristics	742
C.3.2	Measurement of Performance requirements	743
C.3.3	Aggressor cell power allocation for Measurement of Performance Requirements when ABS is Configured	744
C.3.4	Power Allocation for Measurement of Performance Requirements when Quasi Co-location Type B: same Cell ID	745
C.3.5	Simplified CA testing method	745
Annex D (normative):	Characteristics of the interfering signal	747
D.1	General	747
D.2	Interference signals	747
Annex E (normative):	Environmental conditions	748
E.1	General	748
E.2	Environmental	748
E.2.1	Temperature	748
E.2.2	Voltage	748
E.2.3	Vibration	749
Annex F (normative):	Transmit modulation	750
F.1	Measurement Point	750
F.2	Basic Error Vector Magnitude measurement	750
F.3	Basic in-band emissions measurement	751
F.4	Modified signal under test	751
F.5	Window length	753
F.5.1	Timing offset	753
F.5.2	Window length	753
F.5.3	Window length for normal CP	753
F.5.4	Window length for Extended CP	754
F.5.5	Window length for PRACH	754
F.6	Averaged EVM	755
F.7	Spectrum Flatness	756
Annex G (informative):	Reference sensitivity level in lower SNR	757
G.1	General	757
G.2	Typical receiver sensitivity performance (QPSK)	757
G.3	Reference measurement channel for REFSENSE in lower SNR	760
Annex H (normative):	Modified MPR behavior	763
H.1	Indication of modified MPR behavior	763
Annex I (informative):	Change history	764
History	790

Foreword

This Technical Specification (TS) has been produced by the 3rd Generation Partnership Project (3GPP).

The contents of the present document are subject to continuing work within the TSG and may change following formal TSG approval. Should the TSG modify the contents of the present document, it will be re-released by the TSG with an identifying change of release date and an increase in version number as follows:

Version x.y.z

Where:

- x the first digit:
 - 1 presented to TSG for information;
 - 2 presented to TSG for approval;
 - 3 or greater indicates TSG approved document under change control.
- y the second digit is incremented for all changes of substance, i.e. technical enhancements, corrections, updates, etc.
- z the third digit is incremented when editorial only changes have been incorporated in the document.

1 Scope

The present document establishes the minimum RF characteristics and minimum performance requirements for E-UTRA User Equipment (UE).

2 References

The following documents contain provisions which, through reference in this text, constitute provisions of the present document.

- References are either specific (identified by date of publication, edition number, version number, etc.) or non-specific.
- For a specific reference, subsequent revisions do not apply.
- For a non-specific reference, the latest version applies. In the case of a reference to a 3GPP document (including a GSM document), a non-specific reference implicitly refers to the latest version of that document *in the same Release as the present document*.

- [1] 3GPP TR 21.905: "Vocabulary for 3GPP Specifications".
- [2] ITU-R Recommendation SM.329-10, "Unwanted emissions in the spurious domain"
- [3] ITU-R Recommendation M.1545: "Measurement uncertainty as it applies to test limits for the terrestrial component of International Mobile Telecommunications-2000".
- [4] 3GPP TS 36.211: "Physical Channels and Modulation".
- [5] 3GPP TS 36.212: "Multiplexing and channel coding".
- [6] 3GPP TS 36.213: "Physical layer procedures".
- [7] 3GPP TS 36.331: " Requirements for support of radio resource management ".
- [8] 3GPP TS 36.307: " Requirements on User Equipments (UEs) supporting a release-independent frequency band".
- [9] 3GPP TS 36.423: "X2 application protocol (X2AP) ".
- [10] 3GPP TS 23.303: "Technical Specification Group Services and System Aspects; Proximity-based services (ProSe); Stage 2".
- [11] 3GPP TS36.300: "Evolved Universal Terrestrial Radio Access (E-UTRA) and Evolved Universal Terrestrial Radio Access Network (E-UTRAN); Overall description; Stage 2".

3 Definitions, symbols and abbreviations

3.1 Definitions

For the purposes of the present document, the terms and definitions given in TR 21.905 [1] and the following apply in the case of a single component carrier. A term defined in the present document takes precedence over the definition of the same term, if any, in TR 21.905 [1].

Aggregated Channel Bandwidth: The RF bandwidth in which a UE transmits and receives multiple contiguously aggregated carriers.

Aggregated Transmission Bandwidth Configuration: The number of resource block allocated within the aggregated channel bandwidth.

Carrier aggregation: Aggregation of two or more component carriers in order to support wider transmission bandwidths.

Carrier aggregation band: A set of one or more operating bands across which multiple carriers are aggregated with a specific set of technical requirements.

Carrier aggregation bandwidth class: A class defined by the aggregated transmission bandwidth configuration and maximum number of component carriers supported by a UE.

Carrier aggregation configuration: A combination of CA operating band(s) and CA bandwidth class(es) supported by a UE.

Channel edge: The lowest and highest frequency of the carrier, separated by the channel bandwidth.

Channel bandwidth: The RF bandwidth supporting a single E-UTRA RF carrier with the transmission bandwidth configured in the uplink or downlink of a cell. The channel bandwidth is measured in MHz and is used as a reference for transmitter and receiver RF requirements.

Composite spectrum emission mask: Emission mask requirement for intraband non-contiguous carrier aggregation which is a combination of individual sub-block spectrum emissions masks.

Composite spurious emission requirement: Spurious emission requirement for intraband non-contiguous carrier aggregation which is a combination of individual sub-block spurious emission requirements.

Contiguous carriers: A set of two or more carriers configured in a spectrum block where there are no RF requirements based on co-existence for un-coordinated operation within the spectrum block.

Contiguous resource allocation: A resource allocation of consecutive resource blocks within one carrier or across contiguously aggregated carriers. The gap between contiguously aggregated carriers due to the nominal channel spacing is allowed.

Contiguous spectrum: Spectrum consisting of a contiguous block of spectrum with no sub-block gaps.

Enhanced performance requirements type A: This defines performance requirements assuming as baseline receiver reference symbol based linear minimum mean square error interference rejection combining.

Enhanced performance requirements type B: This defines performance requirements assuming as baseline receiver using network assisted interference cancellation and suppression.

Enhanced performance requirements type C: This defines performance requirements assuming as baseline receiver inter-stream interference cancellation.

Inter-band carrier aggregation: Carrier aggregation of component carriers in different operating bands.

NOTE: Carriers aggregated in each band can be contiguous or non-contiguous.

Intra-band contiguous carrier aggregation: Contiguous carriers aggregated in the same operating band.

Intra-band non-contiguous carrier aggregation: Non-contiguous carriers aggregated in the same operating band.

Lower sub-block edge: The frequency at the lower edge of one sub-block. It is used as a frequency reference point for both transmitter and receiver requirements.

Non-contiguous spectrum: Spectrum consisting of two or more sub-blocks separated by sub-block gap(s).

ProSe-enabled UE: A UE that supports ProSe requirements and associated procedures.

NOTE: As defined in TS 23.303 [10].

ProSe Direct Communication: A communication between two or more UEs in proximity that are ProSe-enabled.

NOTE: As defined in TS 23.303 [10].

ProSe Direct Discovery: A procedure employed by a ProSe-enabled UE to discover other ProSe-enabled UEs in its vicinity.

NOTE: As defined in TS 23.303 [10].

Sub-block: This is one contiguous allocated block of spectrum for transmission and reception by the same UE. There may be multiple instances of sub-blocks within an RF bandwidth.

Sub-block bandwidth: The bandwidth of one sub-block.

Sub-block gap: A frequency gap between two consecutive sub-blocks within an RF bandwidth, where the RF requirements in the gap are based on co-existence for un-coordinated operation.

Synchronized operation: Operation of TDD in two different systems, where no simultaneous uplink and downlink occur.

Unsynchronized operation: Operation of TDD in two different systems, where the conditions for synchronized operation are not met.

Upper sub-block edge: The frequency at the upper edge of one sub-block. It is used as a frequency reference point for both transmitter and receiver requirements.

3.2 Symbols

For the purposes of the present document, the following symbols apply:

BW_{Channel}	Channel bandwidth
$BW_{\text{Channel,block}}$	Sub-block bandwidth, expressed in MHz. $BW_{\text{Channel,block}} = F_{\text{edge,block,high}} - F_{\text{edge,block,low}}$.
$BW_{\text{Channel_CA}}$	Aggregated channel bandwidth, expressed in MHz.
BW_{GB}	Virtual guard band to facilitate transmitter (receiver) filtering above / below edge CCs.
E_{RS}	Transmitted energy per RE for reference symbols during the useful part of the symbol, i.e. excluding the cyclic prefix, (average power normalized to the subcarrier spacing) at the eNode B transmit antenna connector
\hat{E}_s	The averaged received energy per RE of the wanted signal during the useful part of the symbol, i.e. excluding the cyclic prefix, at the UE antenna connector; average power is computed within a set of REs used for the transmission of physical channels (including user specific RSs when present), divided by the number of REs within the set, and normalized to the subcarrier spacing
F	Frequency
$F_{\text{agg_alloc_low}}$	Aggregated Transmission Bandwidth Configuration. The lowest frequency of the simultaneously transmitted resource blocks.
$F_{\text{agg_alloc_high}}$	Aggregated Transmission Bandwidth Configuration. The highest frequency of the simultaneously transmitted resource blocks.
$F_{\text{Interferer (offset)}}$	Frequency offset of the interferer
$F_{\text{Interferer}}$	Frequency of the interferer
F_C	Frequency of the carrier centre frequency
F_{C_agg}	Aggregated Transmission Bandwidth Configuration. Center frequency of the aggregated carriers.
$F_{C,block,high}$	Center frequency of the highest transmitted/received carrier in a sub-block.
$F_{C,block,low}$	Center frequency of the lowest transmitted/received carrier in a sub-block.
F_{C_low}	The centre frequency of the <i>lowest carrier</i> , expressed in MHz.
F_{C_high}	The centre frequency of the <i>highest carrier</i> , expressed in MHz.
F_{DL_low}	The lowest frequency of the downlink operating band
F_{DL_high}	The highest frequency of the downlink operating band
F_{UL_low}	The lowest frequency of the uplink operating band
F_{UL_high}	The highest frequency of the uplink operating band
$F_{\text{edge,block,low}}$	The lower sub-block edge, where $F_{\text{edge,block,low}} = F_{C,block,low} - F_{\text{offset}}$.
$F_{\text{edge,block,high}}$	The upper sub-block edge, where $F_{\text{edge,block,high}} = F_{C,block,high} + F_{\text{offset}}$.
$F_{\text{edge_low}}$	The <i>lower edge</i> of aggregated channel bandwidth, expressed in MHz.
$F_{\text{edge_high}}$	The <i>higher edge</i> of aggregated channel bandwidth, expressed in MHz.
F_{offset}	Frequency offset from F_{C_high} to the <i>higher edge</i> or F_{C_low} to the <i>lower edge</i> .
$F_{\text{offset,block,low}}$	Separation between lower edge of a sub-block and the center of the lowest component carrier within the sub-block
$F_{\text{offset,block,high}}$	Separation between higher edge of a sub-block and the center of the highest component carrier within the sub-block
$F_{\text{offset_NS_23}}$	Frequency offset in MHz needed if NS_23 is used
F_{OOB}	The boundary between the E-UTRA out of band emission and spurious emission domains.

I_o	The power spectral density of the total input signal (power averaged over the useful part of the symbols within the transmission bandwidth configuration, divided by the total number of RE for this configuration and normalised to the subcarrier spacing) at the UE antenna connector, including the own-cell downlink signal
I_{or}	The total transmitted power spectral density of the own-cell downlink signal (power averaged over the useful part of the symbols within the transmission bandwidth configuration, divided by the total number of RE for this configuration and normalised to the subcarrier spacing) at the eNode B transmit antenna connector
\hat{I}_{or}	The total received power spectral density of the own-cell downlink signal (power averaged over the useful part of the symbols within the transmission bandwidth configuration, divided by the total number of RE for this configuration and normalised to the subcarrier spacing) at the UE antenna connector
I_{ot}	The received power spectral density of the total noise and interference for a certain RE (average power obtained within the RE and normalized to the subcarrier spacing) as measured at the UE antenna connector
L_{CRB}	Transmission bandwidth which represents the length of a contiguous resource block allocation expressed in units of resources blocks
N_{cp}	Cyclic prefix length
N_{DL}	Downlink EARFCN
N_{oc}	The power spectral density of a white noise source (average power per RE normalised to the subcarrier spacing), simulating interference from cells that are not defined in a test procedure, as measured at the UE antenna connector
N_{oc1}	The power spectral density of a white noise source (average power per RE normalized to the subcarrier spacing), simulating interference in non-CRS symbols in ABS subframe from cells that are not defined in a test procedure, as measured at the UE antenna connector.
N_{oc2}	The power spectral density of a white noise source (average power per RE normalized to the subcarrier spacing), simulating interference in CRS symbols in ABS subframe from all cells that are not defined in a test procedure, as measured at the UE antenna connector.
N_{oc3}	The power spectral density of a white noise source (average power per RE normalised to the subcarrier spacing), simulating interference in non-ABS subframe from cells that are not defined in a test procedure, as measured at the UE antenna connector
N_{oc}'	The power spectral density (average power per RE normalised to the subcarrier spacing) of the summation of the received power spectral densities of the strongest interfering cells explicitly defined in a test procedure plus N_{oc} , as measured at the UE antenna connector. The respective power spectral density of each interfering cell relative to N_{oc}' is defined by its associated DIP value, or the respective power spectral density of each interfering cell relative to N_{oc} is defined by its associated E_s/N_{oc} value.
$N_{Offis-DL}$	Offset used for calculating downlink EARFCN
$N_{Offis-UL}$	Offset used for calculating uplink EARFCN
N_{otx}	The power spectral density of a white noise source (average power per RE normalised to the subcarrier spacing) simulating eNode B transmitter impairments as measured at the eNode B transmit antenna connector
N_{RB}	Transmission bandwidth configuration, expressed in units of resource blocks
N_{RB_agg}	The number of the aggregated RBs within the fully allocated Aggregated Channel bandwidth.
N_{RB_alloc}	Total number of simultaneously transmitted resource blocks in Channel bandwidth or Aggregated Channel Bandwidth.
$N_{RB,c}$	The transmission bandwidth configuration of component carrier c , expressed in units of resource blocks
$N_{RB,largest\ BW}$	The largest transmission bandwidth configuration of the component carriers in the bandwidth combination, expressed in units of resource blocks
N_{RX}	Number of receiver antennas
N_{UL}	Uplink EARFCN.
R_{av}	Minimum average throughput per RB.
$P_{C_{MAX}}$	The configured maximum UE output power.
$P_{C_{MAX},c}$	The configured maximum UE output power for serving cell c .
P_{EMAX}	Maximum allowed UE output power signalled by higher layers. Same as IE P_{Max} , defined in [7].

$P_{EMAX, c}$	Maximum allowed UE output power signalled by higher layers for serving cell c . Same as IE P_{Max} , defined in [7].
$P_{Interferer}$	Modulated mean power of the interferer
$P_{PowerClass}$	$P_{PowerClass}$ is the nominal UE power (i.e., no tolerance).
P_{UMAX}	The measured configured maximum UE output power.
P_{uw}	Power of an unwanted DL signal
P_w	Power of a wanted DL signal
RB_{start}	Indicates the lowest RB index of transmitted resource blocks.
RB_{end}	Indicates the highest RB index of transmitted resource blocks.
Δf_{OOB}	Δ Frequency of Out Of Band emission.
$\Delta R_{IB, c}$	Allowed reference sensitivity relaxation due to support for inter-band CA operation, for serving cell c .
$\Delta T_{IB, c}$	Allowed maximum configured output power relaxation due to support for inter-band CA operation, for serving cell c .
ΔT_C	Allowed operating band edge transmission power relaxation.
$\Delta T_{C, c}$	Allowed operating band edge transmission power relaxation for serving cell c .
ΔT_{ProSe}	Allowed operating band transmission power relaxation due to support of E-UTRA ProSe on an operating band.
ρ_A	According to Clause 5.2 in TS 36.213 [6]
ρ_B	According to Clause 5.2 in TS 36.213 [6]
σ	Test specific auxiliary variable used for the purpose of downlink power allocation, defined in Annex C.3.2.
W_{gap}	Sub-block gap size

3.3 Abbreviations

For the purposes of the present document, the abbreviations given in TR 21.905 [1] and the following apply. An abbreviation defined in the present document takes precedence over the definition of the same abbreviation, if any, in TR 21.905 [1].

ABS	Almost Blank Subframe
ACLR	Adjacent Channel Leakage Ratio
ACS	Adjacent Channel Selectivity
A-MPR	Additional Maximum Power Reduction
AWGN	Additive White Gaussian Noise
BS	Base Station
CA	Carrier Aggregation
CA_X	Intra-band contiguous CA of component carriers in one sub-block within Band X where X is the applicable E-UTRA operating band
CA_X-X	Intra-band non-contiguous CA of component carriers in two sub-blocks within Band X where X is the applicable E-UTRA operating band
CA_X-Y	Inter-band CA of component carrier(s) in one sub-block within Band X and component carrier(s) in one sub-block within Band Y where X and Y are the applicable E-UTRA operating band
CA_X-X-Y	CA of component carriers in two sub-blocks within Band X and component carrier(s) in one sub-block within Band Y where X and Y are the applicable E-UTRA operating bands
CC	Component Carriers
CG	Carrier Group
CPE	Customer Premise Equipment
CPE_X	Customer Premise Equipment for E-UTRA operating band X
CW	Continuous Wave
DC	Dual Connectivity
DC_X-Y	Inter-band DC of component carrier(s) in one sub-block within Band X and component carrier(s) in one sub-block within Band Y where X and Y are the applicable E-UTRA operating band
DL	Downlink
DIP	Dominant Interferer Proportion
EARFCN	E-UTRA Absolute Radio Frequency Channel Number
EPRE	Energy Per Resource Element
E-UTRA	Evolved UMTS Terrestrial Radio Access
EUTRAN	Evolved UMTS Terrestrial Radio Access Network
EVM	Error Vector Magnitude

FDD	Frequency Division Duplex
FRC	Fixed Reference Channel
HD-FDD	Half- Duplex FDD
MCS	Modulation and Coding Scheme
MCG	Master Cell Group
MOP	Maximum Output Power
MPR	Maximum Power Reduction
MSD	Maximum Sensitivity Degradation
OCNG	OFDMA Channel Noise Generator
OFDMA	Orthogonal Frequency Division Multiple Access
OOB	Out-of-band
PA	Power Amplifier
PCC	Primary Component Carrier
P-MPR	Power Management Maximum Power Reduction
ProSe	Proximity-based Services
PSBCH	Physical Sidelink Broadcast CHannel
PSCCH	Physical Sidelink Control CHannel
PSDCH	Physical Sidelink Discovery CHannel
PSS	Primary Synchronization Signal
PSS_RA	PSS-to-RS EPRE ratio for the channel PSS
PSSCH	Physical Sidelink Shared CHannel
PSSS	Primary Sidelink Synchronization Signal
RE	Resource Element
REFSENS	Reference Sensitivity power level
r.m.s	Root Mean Square
SCC	Secondary Component Carrier
SCG	Secondary Cell Group
SINR	Signal-to-Interference-and-Noise Ratio
SNR	Signal-to-Noise Ratio
SSS	Secondary Synchronization Signal
SSS_RA	SSS-to-RS EPRE ratio for the channel SSSSSSSS Secondary Sidelink Synchronization Signal
TDD	Time Division Duplex
UE	User Equipment
UL	Uplink
UL-MIMO	Up Link Multiple Antenna transmission
UMTS	Universal Mobile Telecommunications System
UTRA	UMTS Terrestrial Radio Access
UTRAN	UMTS Terrestrial Radio Access Network
xCH_RA	xCH-to-RS EPRE ratio for the channel xCH in all transmitted OFDM symbols not containing cell-specific RS
xCH_RB	xCH-to-RS EPRE ratio for the channel xCH in all transmitted OFDM symbols containing cell-specific RS

4 General

4.1 Relationship between minimum requirements and test requirements

The Minimum Requirements given in this specification make no allowance for measurement uncertainty. The test specification TS 36.521-1 Annex F defines Test Tolerances. These Test Tolerances are individually calculated for each test. The Test Tolerances are used to relax the Minimum Requirements in this specification to create Test Requirements.

The measurement results returned by the Test System are compared - without any modification - against the Test Requirements as defined by the shared risk principle.

The Shared Risk principle is defined in ITU-R M.1545 [3].

4.2 Applicability of minimum requirements

- a) In this specification the Minimum Requirements are specified as general requirements and additional requirements. Where the Requirement is specified as a general requirement, the requirement is mandated to be met in all scenarios
- b) For specific scenarios for which an additional requirement is specified, in addition to meeting the general requirement, the UE is mandated to meet the additional requirements.
- c) The reference sensitivity power levels defined in subclause 7.3 are valid for the specified reference measurement channels.
- d) Note: Receiver sensitivity degradation may occur when:
 - 1) The UE simultaneously transmits and receives with bandwidth allocations less than the transmission bandwidth configuration (see Figure 5.6-1), and
 - 2) Any part of the downlink transmission bandwidth is within an uplink transmission bandwidth from the downlink center subcarrier.
- e) The spurious emissions power requirements are for the long term average of the power. For the purpose of reducing measurement uncertainty it is acceptable to average the measured power over a period of time sufficient to reduce the uncertainty due to the statistical nature of the signal.

4.3 Void

4.3A Applicability of minimum requirements (CA, UL-MIMO, ProSe, Dual Connectivity, UE category 0)

The requirements in clauses 5, 6 and 7 which are specific to CA, UL-MIMO, ProSe, Dual Connectivity and UE category 0 are specified as suffix A, B, C, D, E where;

- a) Suffix A additional requirements need to support CA
- b) Suffix B additional requirements need to support UL-MIMO
- c) Suffix C additional requirements need to support Dual Connectivity
- d) Suffix D additional requirements need to support ProSe
- e) Suffix E additional requirements need to support UE category 0

A terminal which supports the above features needs to meet both the general requirements and the additional requirement applicable to the additional subclause (suffix A, B, C, D and E) in clauses 5, 6 and 7. Where there is a difference in requirement between the general requirements and the additional subclause requirements (suffix A, B, C, D, and E) in clauses 5, 6 and 7, the tighter requirements are applicable unless stated otherwise in the additional subclause.

A terminal which supports more than one feature (CA, UL-MIMO, ProSe, Dual Connectivity, and UE category 0) in clauses 5, 6 and 7 shall meet all of the separate corresponding requirements.

For a terminal supporting CA, compliance with minimum requirements for non-contiguous intra-band carrier aggregation in any given operating band does not imply compliance with minimum requirements for contiguous intra-band carrier aggregation in the same operating band.

For a terminal supporting CA, compliance with minimum requirements for contiguous intra-band carrier aggregation in any given operating band does not imply compliance with minimum requirements for non-contiguous intra-band carrier aggregation in the same operating band.

A terminal which supports a DL CA configuration shall support all the lower order fallback DL CA combinations and it shall support at least one bandwidth combination set for each of the constituent lower order DL combinations containing all the bandwidths specified within each specific combination set of the upper order DL combination.

A terminal which supports CA, for each supported CA configuration, shall support Pcell transmissions in each of the aggregated Component Carriers unless indicated otherwise in clause 5.6A.1.

Terminal supporting Dual Connectivity configuration shall meet the minimum requirements for corresponding CA configuration (suffix A), unless otherwise specified.

For a terminal that supports ProSe Direct Communication and/or ProSe Direct Discovery, the minimum requirements are applicable when

- the UE is associated with PCell on the ProSe carrier, or
- the UE is not associated with PCell on the ProSe carrier and is provisioned with the preconfigured radio parameters for ProSe Direct Communications that are associated with known Geographical Area.

When the ProSe UE is not associated with PCell on the ProSe carrier, and the UE does not have knowledge of its geographical area, or is provisioned with preconfigured radio parameters that are not associated with any Geographical Area, ProSe transmissions are not allowed, and the requirements in Section 6.3.3D apply.

4.4 RF requirements in later releases

The standardisation of new frequency bands and carrier aggregation configurations (downlink and uplink aggregation) may be independent of a release. However, in order to implement a UE that conforms to a particular release but supports a band of operation or a carrier aggregation configuration that is specified in a later release, it is necessary to specify some extra requirements. TS 36.307 [8] specifies requirements on UEs supporting a frequency band or a carrier aggregation configuration that is independent of release.

NOTE: For UEs conforming to the 3GPP release of the present document, some RF requirements of later releases may be mandatory independent of whether the UE supports the bands specific or carrier aggregation configurations defined in later releases or not. The set of RF requirements of later releases that is also mandatory for UEs conforming to the 3GPP release of the present document is determined by regional regulation.

5 Operating bands and channel arrangement

5.1 General

The channel arrangements presented in this clause are based on the operating bands and channel bandwidths defined in the present release of specifications.

NOTE: Other operating bands and channel bandwidths may be considered in future releases.

5.2 Void

5.3 Void

5.4 Void

5.5 Operating bands

E-UTRA is designed to operate in the operating bands defined in Table 5.5-1.

Table 5.5-1 E-UTRA operating bands

E-UTRA Operating Band	Uplink (UL) operating band BS receive UE transmit		Downlink (DL) operating band BS transmit UE receive		Duplex Mode
	F_{UL_low}	F_{UL_high}	F_{DL_low}	F_{DL_high}	
1	1920 MHz	– 1980 MHz	2110 MHz	– 2170 MHz	FDD
2	1850 MHz	– 1910 MHz	1930 MHz	– 1990 MHz	FDD
3	1710 MHz	– 1785 MHz	1805 MHz	– 1880 MHz	FDD
4	1710 MHz	– 1755 MHz	2110 MHz	– 2155 MHz	FDD
5	824 MHz	– 849 MHz	869 MHz	– 894 MHz	FDD
6 ¹	830 MHz	– 840 MHz	875 MHz	– 885 MHz	FDD
7	2500 MHz	– 2570 MHz	2620 MHz	– 2690 MHz	FDD
8	880 MHz	– 915 MHz	925 MHz	– 960 MHz	FDD
9	1749.9 MHz	– 1784.9 MHz	1844.9 MHz	– 1879.9 MHz	FDD
10	1710 MHz	– 1770 MHz	2110 MHz	– 2170 MHz	FDD
11	1427.9 MHz	– 1447.9 MHz	1475.9 MHz	– 1495.9 MHz	FDD
12	699 MHz	– 716 MHz	729 MHz	– 746 MHz	FDD
13	777 MHz	– 787 MHz	746 MHz	– 756 MHz	FDD
14	788 MHz	– 798 MHz	758 MHz	– 768 MHz	FDD
15	Reserved		Reserved		FDD
16	Reserved		Reserved		FDD
17	704 MHz	– 716 MHz	734 MHz	– 746 MHz	FDD
18	815 MHz	– 830 MHz	860 MHz	– 875 MHz	FDD
19	830 MHz	– 845 MHz	875 MHz	– 890 MHz	FDD
20	832 MHz	– 862 MHz	791 MHz	– 821 MHz	FDD
21	1447.9 MHz	– 1462.9 MHz	1495.9 MHz	– 1510.9 MHz	FDD
22	3410 MHz	– 3490 MHz	3510 MHz	– 3590 MHz	FDD
23	2000 MHz	– 2020 MHz	2180 MHz	– 2200 MHz	FDD
24 ¹⁷	1626.5 MHz	– 1660.5 MHz	1525 MHz	– 1559 MHz	FDD
25	1850 MHz	– 1915 MHz	1930 MHz	– 1995 MHz	FDD
26	814 MHz	– 849 MHz	859 MHz	– 894 MHz	FDD
27	807 MHz	– 824 MHz	852 MHz	– 869 MHz	FDD
28	703 MHz	– 748 MHz	758 MHz	– 803 MHz	FDD
29	N/A		717 MHz	– 728 MHz	FDD ²
30	2305 MHz	– 2315 MHz	2350 MHz	– 2360 MHz	FDD
31	452.5 MHz	– 457.5 MHz	462.5 MHz	– 467.5 MHz	FDD
32	N/A		1452 MHz	– 1496 MHz	FDD ²
33	1900 MHz	– 1920 MHz	1900 MHz	– 1920 MHz	TDD
34	2010 MHz	– 2025 MHz	2010 MHz	– 2025 MHz	TDD
35	1850 MHz	– 1910 MHz	1850 MHz	– 1910 MHz	TDD
36	1930 MHz	– 1990 MHz	1930 MHz	– 1990 MHz	TDD
37	1910 MHz	– 1930 MHz	1910 MHz	– 1930 MHz	TDD
38	2570 MHz	– 2620 MHz	2570 MHz	– 2620 MHz	TDD
39	1880 MHz	– 1920 MHz	1880 MHz	– 1920 MHz	TDD
40	2300 MHz	– 2400 MHz	2300 MHz	– 2400 MHz	TDD
41	2496 MHz	– 2690 MHz	2496 MHz	– 2690 MHz	TDD
42	3400 MHz	– 3600 MHz	3400 MHz	– 3600 MHz	TDD
43	3600 MHz	– 3800 MHz	3600 MHz	– 3800 MHz	TDD
44	703 MHz	– 803 MHz	703 MHz	– 803 MHz	TDD
NOTE 1: Band 6 is not applicable					
NOTE 2: Restricted to E-UTRA operation when carrier aggregation is configured. The downlink operating band is paired with the uplink operating band (external) of the carrier aggregation configuration that is supporting the configured Pcell.					
NOTE 3: Void					
NOTE 4: Void					
NOTE 5: Void					
NOTE 6: Void					
NOTE 7: Void					
NOTE 8: Void					
NOTE 9: Void					

NOTE 10: Void
 NOTE 11: Void
 NOTE 12: Void
 NOTE 13: Void
 NOTE 14: Void
 NOTE 15: Void
 NOTE 16: Void
 NOTE 17: DL operation in this band is restricted to 1526 – 1536 MHz and UL operation is restricted to 1627.5 – 1637.5 MHz and 1646.5 – 1656.5 MHz.

5.5A Operating bands for CA

E-UTRA carrier aggregation is designed to operate in the operating bands defined in Tables 5.5A-1, 5.5A-2, 5.5A-2a and 5.5A-3.

Table 5.5A-1: Intra-band contiguous CA operating bands

E-UTRA CA Band	E-UTRA Band	Uplink (UL) operating band		Downlink (DL) operating band		Duplex Mode
		BS receive / UE transmit		BS transmit / UE receive		
		F_{UL_low}	F_{UL_high}	F_{DL_low}	F_{DL_high}	
CA_1	1	1920 MHz	1980 MHz	2110 MHz	2170 MHz	FDD
CA_2	2	1850 MHz	1910 MHz	1930 MHz	1990 MHz	FDD
CA_3	3	1710MHz	1785MHz	1805MHz	1880MHz	FDD
CA_7	7	2500 MHz	2570 MHz	2620 MHz	2690 MHz	FDD
CA_12	12	699 MHz	716 MHz	729 MHz	746 MHz	FDD
CA_23	23	2000 MHz	2020 MHz	2180 MHz	2200 MHz	FDD
CA_27	27	807 MHz	824 MHz	852 MHz	869 MHz	FDD
CA_38	38	2570 MHz	2620 MHz	2570 MHz	2620 MHz	TDD
CA_39	39	1880 MHz	1920 MHz	1880 MHz	1920 MHz	TDD
CA_40	40	2300 MHz	2400 MHz	2300 MHz	2400 MHz	TDD
CA_41	41	2496 MHz	2690 MHz	2496 MHz	2690 MHz	TDD
CA_42	42	3400 MHz	3600 MHz	3400 MHz	3600 MHz	TDD

Table 5.5A-2: Inter-band CA operating bands (two bands)

E-UTRA CA Band	E-UTRA Band	Uplink (UL) operating band		Downlink (DL) operating band		Duplex Mode
		BS receive / UE transmit		BS transmit / UE receive		
		F_{UL_low}	F_{UL_high}	F_{DL_low}	F_{DL_high}	
CA_1-3	1	1920 MHz	– 1980 MHz	2110 MHz	– 2170 MHz	FDD
	3	1710 MHz	– 1785 MHz	1805 MHz	– 1880 MHz	
CA_1-5	1	1920 MHz	– 1980 MHz	2110 MHz	– 2170 MHz	FDD
	5	824 MHz	– 849 MHz	869 MHz	– 894 MHz	
CA_1-7	1	1920 MHz	– 1980 MHz	2110 MHz	– 2170 MHz	FDD
	7	2500 MHz	– 2570 MHz	2620 MHz	– 2690 MHz	
CA_1-8	1	1920 MHz	– 1980 MHz	2110 MHz	– 2170 MHz	FDD
	8	880 MHz	– 915 MHz	925 MHz	– 960 MHz	
CA_1-11	1	1920 MHz	– 1980 MHz	2110 MHz	– 2170 MHz	FDD
	11	1427.9 MHz	– 1447.9 MHz	1475.9 MHz	– 1495.9 MHz	
CA_1-18	1	1920 MHz	– 1980 MHz	2110 MHz	– 2170 MHz	FDD
	18	815 MHz	– 830 MHz	860 MHz	– 875 MHz	
CA_1-19	1	1920 MHz	– 1980 MHz	2110 MHz	– 2170 MHz	FDD
	19	830 MHz	– 845 MHz	875 MHz	– 890 MHz	
CA_1-20	1	1920 MHz	– 1980 MHz	2110 MHz	– 2170 MHz	FDD
	20	832 MHz	– 862 MHz	791 MHz	– 821 MHz	
CA_1-21	1	1920 MHz	– 1980 MHz	2110 MHz	– 2170 MHz	FDD
	21	1447.9 MHz	– 1462.9 MHz	1495.9 MHz	– 1510.9 MHz	
CA_1-26	1	1920 MHz	– 1980 MHz	2110 MHz	– 2170 MHz	FDD
	26	814 MHz	– 849 MHz	859 MHz	– 894 MHz	
CA_1-28	1	1920 MHz	– 1980 MHz	2110 MHz	– 2170 MHz	FDD
	28	703 MHz	– 748 MHz	758 MHz	– 803 MHz	
CA_1-41	1	1920 MHz	– 1980 MHz	2110 MHz	– 2170 MHz	FDD
	41	2496 MHz	– 2690 MHz	2496 MHz	– 2690 MHz	TDD
CA_1-42	1	1920 MHz	– 1980 MHz	2110 MHz	– 2170 MHz	FDD
	42	3400 MHz	– 3600 MHz	3400 MHz	– 3600 MHz	TDD
CA_2-4	2	1850 MHz	– 1910 MHz	1930 MHz	– 1990 MHz	FDD
	4	1710 MHz	– 1755 MHz	2110 MHz	– 2155 MHz	
CA_2-4-4	2	1850 MHz	– 1910 MHz	1930 MHz	– 1990 MHz	FDD
	4	1710 MHz	– 1755 MHz	2110 MHz	– 2155 MHz	
CA_2-5	2	1850 MHz	– 1910 MHz	1930 MHz	– 1990 MHz	FDD
	5	824 MHz	– 849 MHz	869 MHz	– 894 MHz	
CA_2-2-5	2	1850 MHz	– 1910 MHz	1930 MHz	– 1990 MHz	FDD
	5	824 MHz	– 849 MHz	869 MHz	– 894 MHz	
CA_2-12	2	1850 MHz	– 1910 MHz	1930 MHz	– 1990 MHz	FDD
	12	699 MHz	– 716 MHz	729 MHz	– 746 MHz	
CA_2-13	2	1850 MHz	– 1910 MHz	1930 MHz	– 1990 MHz	FDD
	13	777 MHz	– 787 MHz	746 MHz	– 756 MHz	
CA_2-2-13	2	1850 MHz	– 1910 MHz	1930 MHz	– 1990 MHz	FDD
	13	777 MHz	– 787 MHz	746 MHz	– 756 MHz	
CA_2-17	2	1850 MHz	– 1910 MHz	1930 MHz	– 1990 MHz	FDD
	17	704 MHz	– 716 MHz	734 MHz	– 746 MHz	
CA_2-29	2	1850 MHz	– 1910 MHz	1930 MHz	– 1990 MHz	FDD
	29	N/A		717 MHz	– 728 MHz	
CA_2-30	2	1850 MHz	– 1910 MHz	1930 MHz	– 1990 MHz	FDD
	30	2305 MHz	– 2315 MHz	2350 MHz	– 2360 MHz	
CA_3-5	3	1710 MHz	– 1785 MHz	1805 MHz	– 1880 MHz	FDD
	5	824 MHz	– 849 MHz	869 MHz	– 894 MHz	
CA_3-7	3	1710 MHz	– 1785 MHz	1805 MHz	– 1880 MHz	FDD
	7	2500 MHz	– 2570 MHz	2620 MHz	– 2690 MHz	
CA_3-8	3	1710 MHz	– 1785 MHz	1805 MHz	– 1880 MHz	FDD
	8	880 MHz	– 915 MHz	925 MHz	– 960 MHz	
CA_3-19	3	1710 MHz	– 1785 MHz	1805 MHz	– 1880 MHz	FDD
	19	830 MHz	– 845 MHz	875 MHz	– 890 MHz	
CA_3-20	3	1710 MHz	– 1785 MHz	1805 MHz	– 1880 MHz	FDD
	20	832 MHz	– 862 MHz	791 MHz	– 821 MHz	

CA_3-26	3	1710 MHz	–	1785 MHz	1805 MHz	–	1880 MHz	FDD
	26	814 MHz	–	849 MHz	859 MHz	–	894 MHz	
CA_3-27	3	1710 MHz	–	1785 MHz	1805 MHz	–	1880 MHz	FDD
	27	807 MHz	–	824 MHz	852 MHz	–	869 MHz	
CA_3-28	3	1710 MHz	–	1785 MHz	1805 MHz	–	1880 MHz	FDD
	28	703 MHz	–	748 MHz	758 MHz	–	803 MHz	
CA_3-42	3	1710 MHz	–	1785 MHz	1805 MHz	–	1880 MHz	FDD
	42	3400 MHz	–	3600 MHz	3400 MHz	–	3600 MHz	
CA_4-5	4	1710 MHz	–	1755 MHz	2110 MHz	–	2155 MHz	FDD
	5	824 MHz	–	849 MHz	869 MHz	–	894 MHz	
CA_4-4-5	4	1710 MHz	–	1755 MHz	2110 MHz	–	2155 MHz	FDD
	5	824 MHz	–	849 MHz	869 MHz	–	894 MHz	
CA_4-7	4	1710 MHz	–	1755 MHz	2110 MHz	–	2155 MHz	FDD
	7	2500 MHz	–	2570 MHz	2620 MHz	–	2690 MHz	
CA_4-4-7	4	1710 MHz	–	1755 MHz	2110 MHz	–	2155 MHz	FDD
	7	2500 MHz	–	2570 MHz	2620 MHz	–	2690 MHz	
CA_4-12	4	1710 MHz	–	1755 MHz	2110 MHz	–	2155 MHz	FDD
	12	699 MHz	–	716 MHz	729 MHz	–	746 MHz	
CA_4-4-12	4	1710 MHz	–	1755 MHz	2110 MHz	–	2155 MHz	FDD
	12	699 MHz	–	716 MHz	729 MHz	–	746 MHz	
CA_4-13	4	1710 MHz	–	1755 MHz	2110 MHz	–	2155 MHz	FDD
	13	777 MHz	–	787 MHz	746 MHz	–	756 MHz	
CA_4-4-13	4	1710 MHz	–	1755 MHz	2110 MHz	–	2155 MHz	FDD
	13	777 MHz	–	787 MHz	746 MHz	–	756 MHz	
CA_4-17	4	1710 MHz	–	1755 MHz	2110 MHz	–	2155 MHz	FDD
	17	704 MHz	–	716 MHz	734 MHz	–	746 MHz	
CA_4-27	4	1710 MHz	–	1755 MHz	2110 MHz	–	2155 MHz	FDD
	27	807 MHz	–	824 MHz	852 MHz	–	869 MHz	
CA_4-29	4	1710 MHz	–	1755 MHz	2110 MHz	–	2155 MHz	FDD
	29	N/A			717 MHz	–	728 MHz	
CA_4-30	4	1710 MHz	–	1755 MHz	2110 MHz	–	2155 MHz	FDD
	30	2305 MHz	–	2315 MHz	2350 MHz	–	2360 MHz	
CA_5-7	5	824 MHz	–	849 MHz	869 MHz	–	894 MHz	FDD
	7	2500 MHz	–	2570 MHz	2620 MHz	–	2690 MHz	
CA_5-12	5	824 MHz	–	849 MHz	869 MHz	–	894 MHz	FDD
	12	699 MHz	–	716 MHz	729 MHz	–	746 MHz	
CA_5-13	5	824 MHz	–	849 MHz	869 MHz	–	894 MHz	FDD
	13	777 MHz	–	787 MHz	746 MHz	–	756 MHz	
CA_5-17	5	824 MHz	–	849 MHz	869 MHz	–	894 MHz	FDD
	17	704 MHz	–	716 MHz	734 MHz	–	746 MHz	
CA_5-25	5	824 MHz	–	849 MHz	869 MHz	–	894 MHz	FDD
	25	1850 MHz	–	1915 MHz	1930 MHz	–	1995 MHz	
CA_5-30	5	824 MHz	–	849 MHz	869 MHz	–	894 MHz	FDD
	30	2305 MHz	–	2315 MHz	2350 MHz	–	2360 MHz	
CA_7-8	7	2500 MHz	–	2570 MHz	2620 MHz	–	2690 MHz	FDD
	8	880 MHz	–	915 MHz	925 MHz	–	960 MHz	
CA_7-12	7	2500 MHz	–	2570 MHz	2620 MHz	–	2690 MHz	FDD
	12	699 MHz	–	716 MHz	729 MHz	–	746 MHz	
CA_7-20	7	2500 MHz	–	2570 MHz	2620 MHz	–	2690 MHz	FDD
	20	832 MHz	–	862 MHz	791 MHz	–	821 MHz	
CA_7-28	7	2500 MHz	–	2570 MHz	2620 MHz	–	2690 MHz	FDD
	28	703 MHz	–	748 MHz	758 MHz	–	803 MHz	
CA_8-11	8	880 MHz	–	915 MHz	925 MHz	–	960 MHz	FDD
	11	1427.9 MHz	–	1447.9 MHz	1475.9 MHz	–	1495.9 MHz	
CA_8-20	8	880 MHz	–	915 MHz	925 MHz	–	960 MHz	FDD
	20	832 MHz	–	862 MHz	791 MHz	–	821 MHz	
CA_8-40	8	880 MHz	–	915 MHz	925 MHz	–	960 MHz	FDD
	40	2300 MHz	–	2400 MHz	2300 MHz	–	2400 MHz	
CA_11-18	11	1427.9 MHz	–	1447.9 MHz	1475.9 MHz	–	1495.9 MHz	FDD
	18	815 MHz	–	830 MHz	860 MHz	–	875 MHz	

CA_12-25	12	699 MHz	–	716 MHz	729 MHz	–	746 MHz	FDD
	25	1850 MHz	–	1915 MHz	1930 MHz	–	1995 MHz	
CA_12-30	12	699 MHz	–	716 MHz	729 MHz	–	746 MHz	FDD
	30	2305 MHz	–	2315 MHz	2350 MHz	–	2360 MHz	
CA_18-28	18	815 MHz	–	830 MHz	860 MHz	–	875 MHz	FDD
	28	703 MHz	–	733 MHz ¹	758 MHz	–	788 MHz ¹	
CA_19-21	19	830 MHz	–	845 MHz	875 MHz	–	890 MHz	FDD
	21	1447.9 MHz	–	1462.9 MHz	1495.9 MHz	–	1510.9 MHz	
CA_19-42	19	830 MHz	–	845 MHz	875 MHz	–	890 MHz	FDD
	42	3400 MHz	–	3600 MHz	3400 MHz	–	3600 MHz	TDD
CA_20-32	20	832 MHz	–	862 MHz	791 MHz	–	821 MHz	FDD
	32	N/A			1452 MHz	–	1496 MHz	
CA_23-29	23	2000 MHz	–	2020 MHz	2180 MHz	–	2200 MHz	FDD
	29	N/A			717 MHz	–	728 MHz	
CA_25-41	25	1850 MHz	–	1915 MHz	1930 MHz	–	1995 MHz	FDD
	41	2496 MHz	–	2690 MHz	2496 MHz	–	2690 MHz	TDD
CA_26-41	26	814 MHz	–	849 MHz	859 MHz	–	894 MHz	FDD
	41	2496 MHz	–	2690 MHz	2496 MHz	–	2690 MHz	TDD
CA_29-30	29	N/A			717 MHz	–	728 MHz	FDD
	30	2305 MHz	–	2315 MHz	2350 MHz	–	2360 MHz	
CA_39-41	39	1880 MHz	–	1920 MHz	1880 MHz	–	1920 MHz	TDD
	41	2496 MHz	–	2690 MHz	2496 MHz	–	2690 MHz	
CA_41-42	41	2496 MHz	–	2690 MHz	2496 MHz	–	2690 MHz	TDD
	42	3400 MHz	–	3600 MHz	3400 MHz	–	3600 MHz	
NOTE 1: The frequency range in band 28 is restricted for this CA band combination.								

Table 5.5A-2a: Inter-band CA operating bands (three bands)

E-UTRA CA Band	E-UTRA Band	Uplink (UL) operating band		Downlink (DL) operating band		Duplex Mode
		BS receive / UE transmit		BS transmit / UE receive		
		F_{UL_low}	F_{UL_high}	F_{DL_low}	F_{DL_high}	
CA_1-3-5	1	1920 MHz	– 1980 MHz	2110 MHz	– 2170 MHz	FDD
	3	1710 MHz	– 1785 MHz	1805 MHz	– 1880 MHz	
	5	824 MHz	– 849 MHz	869 MHz	– 894 MHz	
CA_1-3-8	1	1920 MHz	– 1980 MHz	2110 MHz	– 2170 MHz	FDD
	3	1710 MHz	– 1785 MHz	1805 MHz	– 1880 MHz	
	8	880 MHz	– 915 MHz	925 MHz	– 960 MHz	
CA_1-3-19	1	1920 MHz	– 1980 MHz	2110 MHz	– 2170 MHz	FDD
	3	1710 MHz	– 1785 MHz	1805 MHz	– 1880 MHz	
	19	830 MHz	– 845 MHz	875 MHz	– 890 MHz	
CA_1-3-20	1	1920 MHz	– 1980 MHz	2110 MHz	– 2170 MHz	FDD
	3	1710 MHz	– 1785 MHz	1805 MHz	– 1880 MHz	
	20	832 MHz	– 862 MHz	791 MHz	– 821 MHz	
CA_1-3-26	1	1920 MHz	– 1980 MHz	2110 MHz	– 2170 MHz	FDD
	3	1710 MHz	– 1785 MHz	1805 MHz	– 1880 MHz	
	26	814 MHz	– 849 MHz	859 MHz	– 894 MHz	
CA_1-5-7	1	1920 MHz	– 1980 MHz	2110 MHz	– 2170 MHz	FDD
	5	824 MHz	– 849 MHz	869 MHz	– 894 MHz	
	7	2500 MHz	– 2570 MHz	2620 MHz	– 2690 MHz	
CA_1-7-20	1	1920 MHz	– 1980 MHz	2110 MHz	– 2170 MHz	FDD
	7	2500 MHz	– 2570 MHz	2620 MHz	– 2690 MHz	
	20	832 MHz	– 862 MHz	791 MHz	– 821 MHz	
CA_1-18-28	1	1920 MHz	– 1980 MHz	2110 MHz	– 2170 MHz	FDD
	18	815 MHz	– 830 MHz	860 MHz	– 875 MHz	
	28	703 MHz	– 733 MHz ¹	758 MHz	– 788 MHz ¹	
CA_1-19-21	1	1920 MHz	– 1980 MHz	2110 MHz	– 2170 MHz	FDD
	19	830 MHz	– 845 MHz	875 MHz	– 890 MHz	
	21	1447.9 MHz	– 1462.9 MHz	1495.9 MHz	– 1510.9 MHz	
CA_2-4-5	2	1850 MHz	– 1910 MHz	1930 MHz	– 1990 MHz	FDD
	4	1710 MHz	– 1755 MHz	2110 MHz	– 2155 MHz	
	5	824 MHz	– 849 MHz	869 MHz	– 894 MHz	
CA_2-4-12	2	1850 MHz	– 1910 MHz	1930 MHz	– 1990 MHz	FDD
	4	1710 MHz	– 1755 MHz	2110 MHz	– 2155 MHz	
	12	699 MHz	– 716 MHz	729 MHz	– 746 MHz	
CA_2-4-13	2	1850 MHz	– 1910 MHz	1930 MHz	– 1990 MHz	FDD
	4	1710 MHz	– 1755 MHz	2110 MHz	– 2155 MHz	
	13	777 MHz	– 787 MHz	746 MHz	– 756 MHz	
CA_2-4-29	2	1850 MHz	– 1910 MHz	1930 MHz	– 1990 MHz	FDD
	4	1710 MHz	– 1755 MHz	2110 MHz	– 2155 MHz	
	29	N/A		717 MHz	– 728 MHz	
CA_2-5-12	2	1850 MHz	– 1910 MHz	1930 MHz	– 1990 MHz	FDD
	5	824 MHz	– 849 MHz	869 MHz	– 894 MHz	
	12	699 MHz	– 716 MHz	729 MHz	– 746 MHz	
CA_2-5-13	2	1850 MHz	– 1910 MHz	1930 MHz	– 1990 MHz	FDD
	5	824 MHz	– 849 MHz	869 MHz	– 894 MHz	
	13	777 MHz	– 787 MHz	746 MHz	– 756 MHz	
CA_2-5-30	2	1850 MHz	– 1910 MHz	1930 MHz	– 1990 MHz	FDD
	5	824 MHz	– 849 MHz	869 MHz	– 894 MHz	
	30	2305 MHz	– 2315 MHz	2350 MHz	– 2360 MHz	
CA_2-12-30	2	1850 MHz	– 1910 MHz	1930 MHz	– 1990 MHz	FDD
	12	699 MHz	– 716 MHz	729 MHz	– 746 MHz	
	30	2305 MHz	– 2315 MHz	2350 MHz	– 2360 MHz	
CA_2-29-30	2	1850 MHz	– 1910 MHz	1930 MHz	– 1990 MHz	FDD
	29	N/A		717 MHz	– 728 MHz	
	30	2305 MHz	– 2315 MHz	2350 MHz	– 2360 MHz	
CA_3-7-20	3	1710 MHz	– 1785 MHz	1805 MHz	– 1880 MHz	FDD
	7	2500 MHz	– 2570 MHz	2620 MHz	– 2690 MHz	

	20	832 MHz	–	862 MHz	791 MHz	–	821 MHz	
CA_4-5-12	4	1710 MHz	–	1755 MHz	2110 MHz	–	2155 MHz	FDD
	5	824 MHz	–	849 MHz	869 MHz	–	894 MHz	
	12	699 MHz	–	716 MHz	729 MHz	–	746 MHz	
CA_4-5-13	4	1710 MHz	–	1755 MHz	2110 MHz	–	2155 MHz	FDD
	5	824 MHz	–	849 MHz	869 MHz	–	894 MHz	
	13	777 MHz	–	787 MHz	746 MHz	–	756 MHz	
CA_4-5-30	4	1710 MHz	–	1755 MHz	2110 MHz	–	2155 MHz	FDD
	5	824 MHz	–	849 MHz	869 MHz	–	894 MHz	
	30	2305 MHz	–	2315 MHz	2350 MHz	–	2360 MHz	
CA_4-7-12	4	1710 MHz	–	1755 MHz	2110 MHz	–	2155 MHz	FDD
	7	2500 MHz	–	2570 MHz	2620 MHz	–	2690 MHz	
	12	699 MHz	–	716 MHz	729 MHz	–	746 MHz	
CA_4-12-30	4	1710 MHz	–	1755 MHz	2110 MHz	–	2155 MHz	FDD
	12	699 MHz	–	716 MHz	729 MHz	–	746 MHz	
	30	2305 MHz	–	2315 MHz	2350 MHz	–	2360 MHz	
CA_4-29-30	4	1710 MHz	–	1755 MHz	2110 MHz	–	2155 MHz	FDD
	29	N/A			717 MHz	–	728 MHz	
	30	2305 MHz	–	2315 MHz	2350 MHz	–	2360 MHz	
CA_7-8-20	7	2500 MHz	–	2570 MHz	2620 MHz	–	2690 MHz	FDD
	8	880 MHz	–	915 MHz	925 MHz	–	960 MHz	
	20	832 MHz	–	862 MHz	791 MHz	–	821 MHz	

NOTE 1: The frequency range in band 28 is restricted for this CA band combination.

Table 5.5A-3: Intra-band non-contiguous CA operating bands (with two sub-blocks)

E-UTRA CA Band	E-UTRA Band	Uplink (UL) operating band		Downlink (DL) operating band		Duplex Mode		
		BS receive / UE transmit		BS transmit / UE receive				
		F_{UL_low}	F_{UL_high}	F_{DL_low}	F_{DL_high}			
CA_2-2	2	1850 MHz	–	1910 MHz	1930 MHz	–	1990 MHz	FDD
CA_3-3	3	1710 MHz	–	1785 MHz	1805 MHz	–	1880 MHz	FDD
CA_4-4	4	1710 MHz	–	1755 MHz	2110 MHz	–	2155 MHz	FDD
CA_7-7	7	2500 MHz	–	2570 MHz	2620 MHz	–	2690 MHz	FDD
CA_23-23	23	2000 MHz	–	2020 MHz	2180 MHz	–	2200 MHz	FDD
CA_25-25	25	1850 MHz	–	1915 MHz	1930 MHz	–	1995 MHz	FDD
CA_41-41	41	2496 MHz	–	2690 MHz	2496 MHz	–	2690 MHz	TDD
CA_42-42	42	3400 MHz	–	3600 MHz	3400 MHz	–	3600 MHz	TDD

5.5B Operating bands for UL-MIMO

E-UTRA UL-MIMO is designed to operate in the operating bands defined in Table 5.5B-1.

Table 5.5B-1: Void

5.5C Operating bands for Dual Connectivity

E-UTRA dual connectivity is designed to operate in the operating bands defined in Table 5.5C-1.

Table 5.5C-1: Inter-band dual connectivity operating bands (two bands)

E-UTRA DC Band	E-UTRA Band	Uplink (UL) operating band			Downlink (DL) operating band			Duplex Mode
		BS receive / UE transmit			BS transmit / UE receive			
		F_{UL_low}	–	F_{UL_high}	F_{DL_low}	–	F_{DL_high}	
DC_1-3	1	1920 MHz	–	1980 MHz	2110 MHz	–	2170 MHz	FDD
	3	1710 MHz	–	1785 MHz	1805 MHz	–	1880 MHz	
DC_1-5	1	1920 MHz	–	1980 MHz	2110 MHz	–	2170 MHz	FDD
	5	824 MHz	–	849 MHz	869 MHz	–	894 MHz	
DC_1-7	1	1920 MHz	–	1980 MHz	2110 MHz	–	2170 MHz	FDD
	7	2500 MHz	–	2570 MHz	2620 MHz	–	2690 MHz	
DC_1-8	1	1920 MHz	–	1980 MHz	2110 MHz	–	2170 MHz	FDD
	8	880 MHz	–	915 MHz	925 MHz	–	960 MHz	
DC_1-19	1	1920 MHz	–	1980 MHz	2110 MHz	–	2170 MHz	FDD
	19	830 MHz	–	845 MHz	875 MHz	–	890 MHz	
DC_1-21	1	1920 MHz	–	1980 MHz	2110 MHz	–	2170 MHz	FDD
	21	1447.9 MHz	–	1462.9 MHz	1495.9 MHz	–	1510.9 MHz	
DC_2-4	2	1850 MHz	–	1910 MHz	1930 MHz	–	1990 MHz	FDD
	4	1710 MHz	–	1755 MHz	2110 MHz	–	2155 MHz	
DC_2-13	2	1850 MHz	–	1910 MHz	1930 MHz	–	1990 MHz	FDD
	13	777 MHz	–	787 MHz	746 MHz	–	756 MHz	
DC_3-5	3	1710 MHz	–	1785 MHz	1805 MHz	–	1880 MHz	FDD
	5	824 MHz	–	849 MHz	869 MHz	–	894 MHz	
DC_3-7	3	1710 MHz	–	1785 MHz	1805 MHz	–	1880 MHz	FDD
	7	2500 MHz	–	2570 MHz	2620 MHz	–	2690 MHz	
DC_3-8	3	1710 MHz	–	1785 MHz	1805 MHz	–	1880 MHz	FDD
	8	880 MHz	–	915 MHz	925 MHz	–	960 MHz	
DC_3-19	3	1710 MHz	–	1785 MHz	1805 MHz	–	1880 MHz	FDD
	19	830 MHz	–	845 MHz	875 MHz	–	890 MHz	
DC_3-20	3	1710 MHz	–	1785 MHz	1805 MHz	–	1880 MHz	FDD
	20	832 MHz	–	862 MHz	791 MHz	–	821 MHz	
DC_3-26	3	1710 MHz	–	1785 MHz	1805 MHz	–	1880 MHz	FDD
	26	814 MHz	–	849 MHz	859 MHz	–	894 MHz	
DC_4-7	4	1710 MHz	–	1755 MHz	2110 MHz	–	2155 MHz	FDD
	7	2500 MHz	–	2570 MHz	2620 MHz	–	2690 MHz	
DC_4-12	4	1710 MHz	–	1755 MHz	2110 MHz	–	2155 MHz	FDD
	12	699 MHz	–	716 MHz	729 MHz	–	746 MHz	
DC_4-13	4	1710 MHz	–	1755 MHz	2110 MHz	–	2155 MHz	FDD
	13	777 MHz	–	787 MHz	746 MHz	–	756 MHz	
DC_4-17	4	1710 MHz	–	1755 MHz	2110 MHz	–	2155 MHz	FDD
	17	704 MHz	–	716 MHz	734 MHz	–	746 MHz	
DC_5-7	5	824 MHz	–	849 MHz	869 MHz	–	894 MHz	FDD
	7	2500 MHz	–	2570 MHz	2620 MHz	–	2690 MHz	
DC_5-12	5	824 MHz	–	849 MHz	869 MHz	–	894 MHz	FDD
	12	699 MHz	–	716 MHz	729 MHz	–	746 MHz	
DC_5-17	5	824 MHz	–	849 MHz	869 MHz	–	894 MHz	FDD
	17	704 MHz	–	716 MHz	734 MHz	–	746 MHz	
DC_7-20	7	2500 MHz	–	2570 MHz	2620 MHz	–	2690 MHz	FDD
	20	832 MHz	–	862 MHz	791 MHz	–	821 MHz	
DC_7-28	7	2500 MHz	–	2570 MHz	2620 MHz	–	2690 MHz	FDD
	28	703 MHz	–	748 MHz	758 MHz	–	803 MHz	
DC_19-21	19	830 MHz	–	845 MHz	875 MHz	–	890 MHz	FDD
	21	1447.9 MHz	–	1462.9 MHz	1495.9 MHz	–	1510.9 MHz	
DC_39-41	39	1880 MHz	–	1920 MHz	1880 MHz	–	1920 MHz	TDD
	41	2496 MHz	–	2690 MHz	2496 MHz	–	2690 MHz	

NOTE 1: The DC configurations will follow corresponding CA configurations as defined in Table 5.6A.1-2.

5.5D Operating bands for ProSe

E-UTRA ProSe is designed to operate in the operating bands defined in Table 5.5D-1.

Table 5.5D-1 E-UTRA ProSe operating band

E-UTRA ProSe Band	E-UTRA Operating Band	ProSe UE transmit	ProSe UE receive	ProSe Duplex Mode	ProSe Direct	
		F_{UL_low} – F_{UL_high}	F_{DL_low} – F_{DL_high}		Disc.	Comm.
2	2	1850 MHz – 1910 MHz	1850 MHz – 1910 MHz	HD	Yes	
3	3	1710 MHz – 1785 MHz	1710 MHz – 1785 MHz	HD	Yes	Yes
4	4	1710 MHz – 1755 MHz	1710 MHz – 1755 MHz	HD	Yes	
7	7	2500 MHz – 2570 MHz	2500 MHz – 2570 MHz	HD	Yes	Yes
14	14	788 MHz – 798 MHz	788 MHz – 798 MHz	HD	Yes	Yes
20	20	832 MHz – 862 MHz	832 MHz – 862 MHz	HD	Yes	Yes
26	26	814 MHz – 849 MHz	814 MHz – 849 MHz	HD	Yes	Yes
28	28	703 MHz – 748 MHz	703 MHz – 748 MHz	HD	Yes	Yes
31	31	452.5 MHz – 457.5 MHz	452.5 MHz – 457.5 MHz	HD	Yes	Yes
41	41	2496 MHz – 2690 MHz	2496 MHz – 2690 MHz	HD	Yes	

5.5E Operating bands for UE category 0

UE category 0 is designed to operate in the E-UTRA operating bands 2, 3, 4, 5, 8, 13, and 20 in both half duplex FDD mode and full-duplex FDD mode and in bands 39 and 41 in TDD mode. The E-UTRA bands are defined in Table 5.5-1.

5.6 Channel bandwidth

Requirements in present document are specified for the channel bandwidths listed in Table 5.6-1.

Table 5.6-1: Transmission bandwidth configuration N_{RB} in E-UTRA channel bandwidths

Channel bandwidth $BW_{Channel}$ [MHz]	1.4	3	5	10	15	20
Transmission bandwidth configuration N_{RB}	6	15	25	50	75	100

Figure 5.6-1 shows the relation between the Channel bandwidth ($BW_{Channel}$) and the Transmission bandwidth configuration (N_{RB}). The channel edges are defined as the lowest and highest frequencies of the carrier separated by the channel bandwidth, i.e. at $F_C \pm BW_{Channel} / 2$.

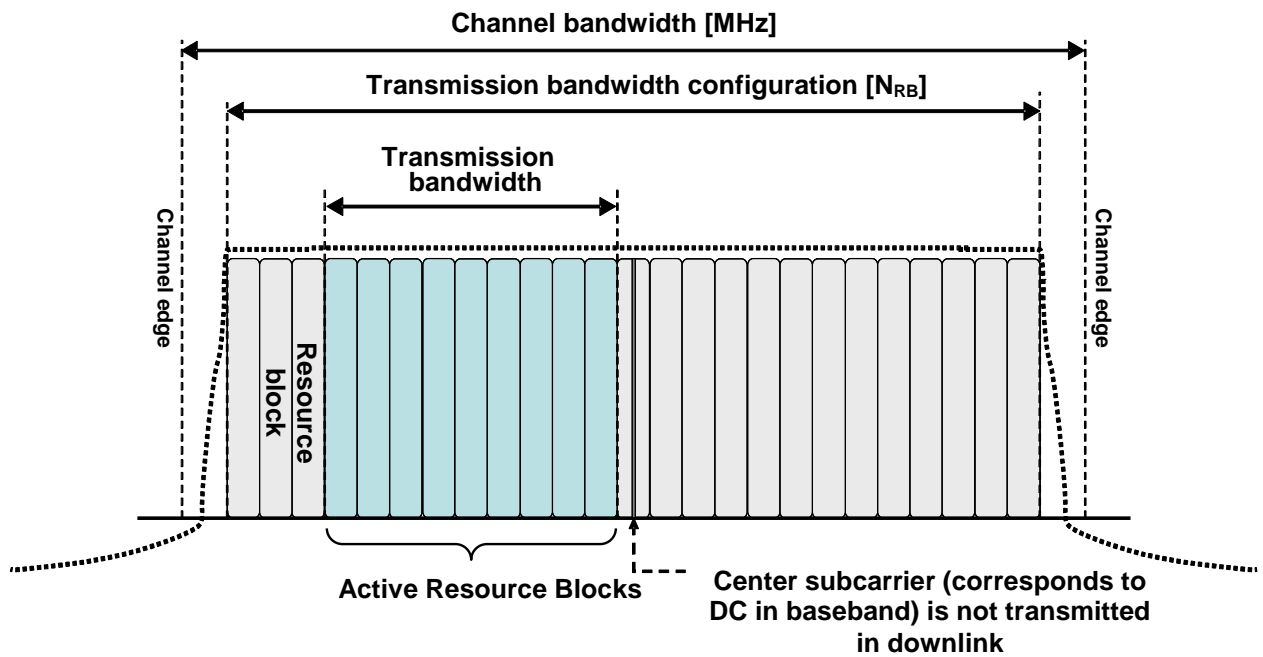

Figure 5.6-1: Definition of channel bandwidth and transmission bandwidth configuration for one E-UTRA carrier

5.6.1 Channel bandwidths per operating band

a) The requirements in this specification apply to the combination of channel bandwidths and operating bands shown in Table 5.6.1-1. The transmission bandwidth configuration in Table 5.6.1-1 shall be supported for each of the specified channel bandwidths. The same (symmetrical) channel bandwidth is specified for both the TX and RX path.

Table 5.6.1-1: E-UTRA channel bandwidth

E-UTRA Band	E-UTRA band / Channel bandwidth					
	1.4 MHz	3 MHz	5 MHz	10 MHz	15 MHz	20 MHz
1			Yes	Yes	Yes	Yes
2	Yes	Yes	Yes	Yes	Yes ¹	Yes ¹
3	Yes	Yes	Yes	Yes	Yes ¹	Yes ¹
4	Yes	Yes	Yes	Yes	Yes	Yes
5	Yes	Yes	Yes	Yes ¹		
6			Yes	Yes ¹		
7			Yes	Yes	Yes ³	Yes ^{1, 3}
8	Yes	Yes	Yes	Yes ¹		
9			Yes	Yes	Yes ¹	Yes ¹
10			Yes	Yes	Yes	Yes
11			Yes	Yes ¹		
12	Yes	Yes	Yes ¹	Yes ¹		
13			Yes ¹	Yes ¹		
14			Yes ¹	Yes ¹		
...						
17			Yes ¹	Yes ¹		
18			Yes	Yes ¹	Yes ¹	
19			Yes	Yes ¹	Yes ¹	
20			Yes	Yes ¹	Yes ¹	Yes ¹
21			Yes	Yes ¹	Yes ¹	
22			Yes	Yes	Yes ¹	Yes ¹
23	Yes	Yes	Yes	Yes	Yes ¹	Yes ¹
24			Yes	Yes		
25	Yes	Yes	Yes	Yes	Yes ¹	Yes ¹
26	Yes	Yes	Yes	Yes ¹	Yes ¹	
27	Yes	Yes	Yes	Yes ¹		
28		Yes	Yes	Yes ¹	Yes ¹	Yes ^{1, 2}
30			Yes	Yes ¹		
31	Yes	Yes ¹	Yes ¹			
...						
33			Yes	Yes	Yes	Yes
34			Yes	Yes	Yes	
35	Yes	Yes	Yes	Yes	Yes	Yes
36	Yes	Yes	Yes	Yes	Yes	Yes
37			Yes	Yes	Yes	Yes
38			Yes	Yes	Yes ³	Yes ³
39			Yes	Yes	Yes ³	Yes ³
40			Yes	Yes	Yes	Yes
41			Yes	Yes	Yes	Yes
42			Yes	Yes	Yes	Yes
43			Yes	Yes	Yes	Yes
44		Yes	Yes	Yes	Yes	Yes
NOTE 1: ¹ refers to the bandwidth for which a relaxation of the specified UE receiver sensitivity requirement (subclause 7.3) is allowed.						
NOTE 2: ² For the 20 MHz bandwidth, the minimum requirements are specified for E-UTRA UL carrier frequencies confined to either 713-723 MHz or 728-738 MHz						
NOTE 3: ³ refers to the bandwidth for which the uplink transmission bandwidth can be restricted by the network for some channel assignments in FDD/TDD co-existence scenarios in order to meet unwanted emissions requirements (Clause 6.6.3.2).						

b) The use of different (asymmetrical) channel bandwidth for the TX and RX is not precluded and is intended to form part of a later release.

5.6A Channel bandwidth for CA

For intra-band contiguous carrier aggregation *Aggregated Channel Bandwidth*, *Aggregated Transmission Bandwidth Configuration* and *Guard Bands* are defined as follows, see Figure 5.6A-1.

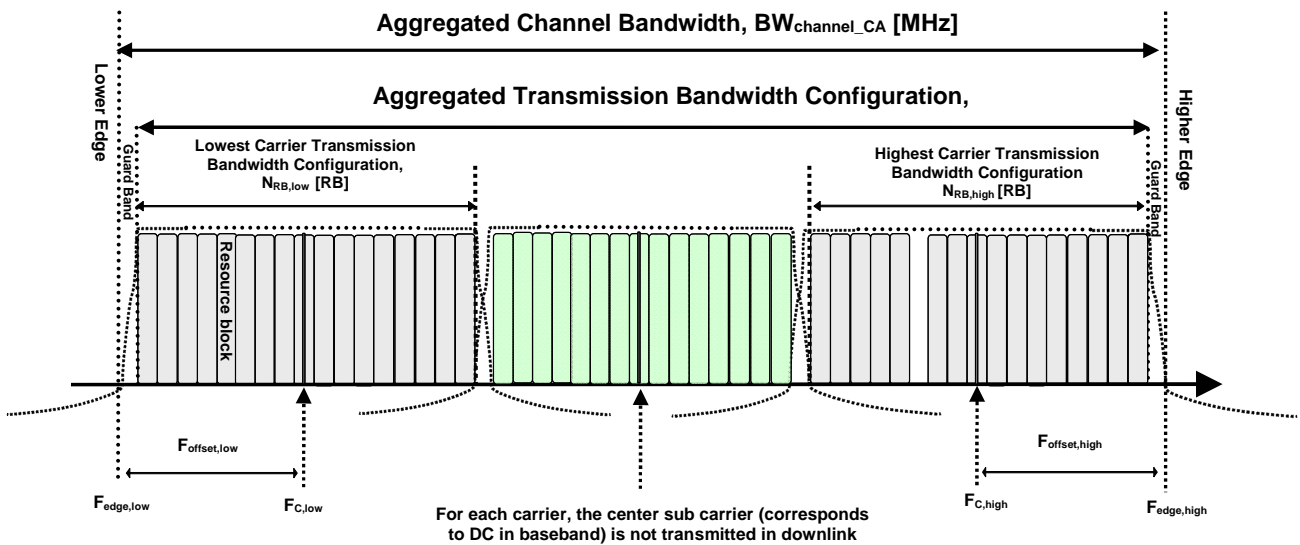

Figure 5.6A-1. Definition of Aggregated channel bandwidth and aggregated channel bandwidth edges

The *aggregated channel bandwidth*, $BW_{Channel_CA}$, is defined as

$$BW_{Channel_CA} = F_{edge,high} - F_{edge,low} \text{ [MHz].}$$

The lower bandwidth edge $F_{edge,low}$ and the upper bandwidth edge $F_{edge,high}$ of the aggregated channel bandwidth are used as frequency reference points for transmitter and receiver requirements and are defined by

$$F_{edge,low} = F_{C,low} - F_{offset,low}$$

$$F_{edge,high} = F_{C,high} + F_{offset,high}$$

The lower and upper frequency offsets depend on the transmission bandwidth configurations of the lowest and highest assigned edge component carrier and are defined as

$$F_{offset,low} = (0.18N_{RB,low} + \Delta f_1)/2 + BW_{GB} \text{ [MHz]}$$

$$F_{offset,high} = (0.18N_{RB,high} + \Delta f_1)/2 + BW_{GB} \text{ [MHz]}$$

where $\Delta f_1 = \Delta f$ for the downlink with Δf the subcarrier spacing and $\Delta f_1 = 0$ for the uplink, while $N_{RB,low}$ and $N_{RB,high}$ are the transmission bandwidth configurations according to Table 5.6-1 for the lowest and highest assigned component carrier, respectively. BW_{GB} denotes the *Nominal Guard Band* and is defined in Table 5.6A-1, and the factor 0.18 is the PRB bandwidth in MHz.

NOTE: The values of $BW_{Channel_CA}$ for UE and BS are the same if the lowest and the highest component carriers are identical.

Aggregated Transmission Bandwidth Configuration is the number of the aggregated RBs within the fully allocated Aggregated Channel bandwidth and is defined per CA Bandwidth Class (Table 5.6A-1).

For intra-band non-contiguous carrier aggregation *Sub-block Bandwidth* and *Sub-block edges* are defined as follows, see Figure 5.6A-2.

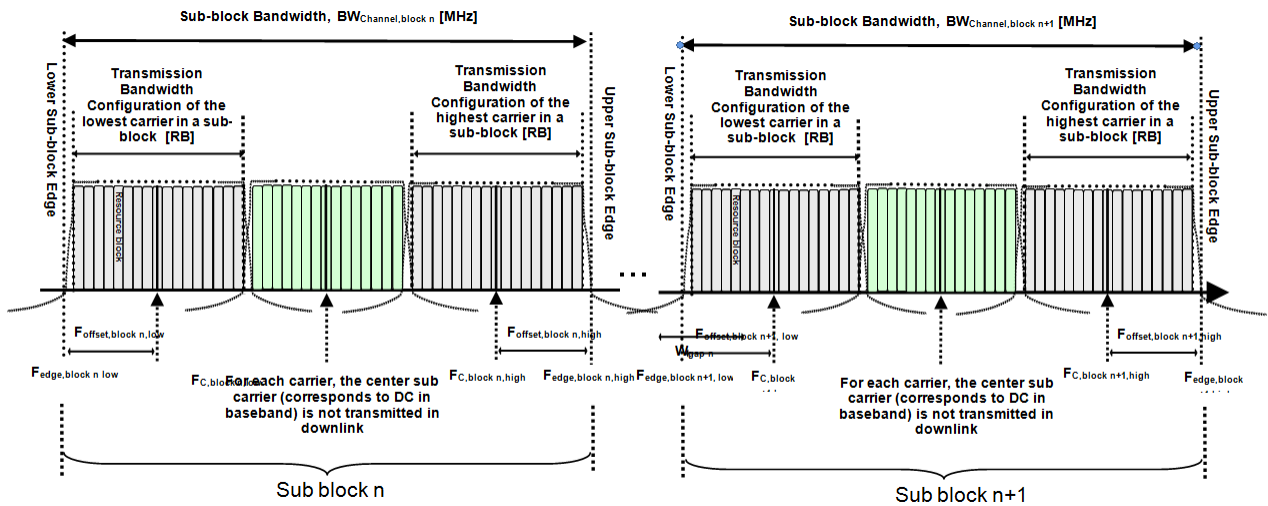

Figure 5.6A-2. Non-contiguous intraband CA terms and definitions

The lower sub-block edge of the Sub-block Bandwidth ($BW_{Channel,block}$) is defined as

$$F_{edge,block,low} = F_{C,block,low} - F_{offset,block,low}$$

The upper sub-block edge of the Sub-block Bandwidth is defined as

$$F_{edge,block,high} = F_{C,block,high} + F_{offset,block,high}$$

The Sub-block Bandwidth, $BW_{Channel,block}$, is defined as follows:

$$BW_{Channel,block} = F_{edge,block,high} - F_{edge,block,low} \text{ [MHz]}$$

The lower and upper frequency offsets $F_{offset,block,low}$ and $F_{offset,block,high}$ depend on the transmission bandwidth configurations of the lowest and highest assigned edge component carriers within a sub-block and are defined as

$$F_{offset,block,low} = (0.18N_{RB,low} + \Delta f_1)/2 + BW_{GB} \text{ [MHz]}$$

$$F_{offset,block,high} = (0.18N_{RB,high} + \Delta f_1)/2 + BW_{GB} \text{ [MHz]}$$

where $\Delta f_1 = \Delta f$ for the downlink with Δf the subcarrier spacing and $\Delta f_1 = 0$ for the uplink, while $N_{RB,low}$ and $N_{RB,high}$ are the transmission bandwidth configurations according to Table 5.6-1 for the lowest and highest assigned component carrier within a sub-block, respectively. BW_{GB} denotes the *Nominal Guard Band* and is defined in Table 5.6A-1, and the factor 0.18 is the PRB bandwidth in MHz.

The sub-block gap size between two consecutive sub-blocks W_{gap} is defined as

$$W_{gap} = F_{edge,block\ n+1,low} - F_{edge,block\ n,high} \text{ [MHz]}$$

Table 5.6A-1: CA bandwidth classes and corresponding nominal guard bands

CA Bandwidth Class	Aggregated Transmission Bandwidth Configuration	Number of contiguous CC	Nominal Guard Band BW_{GB}
A	$N_{RB,agg} \leq 100$	1	$a_1 BW_{Channel(1)} - 0.5\Delta f_1$ (NOTE 2)
B	$25 < N_{RB,agg} \leq 100$	2	$0.05 \max(BW_{Channel(1)}, BW_{Channel(2)}) - 0.5\Delta f_1$
C	$100 < N_{RB,agg} \leq 200$	2	$0.05 \max(BW_{Channel(1)}, BW_{Channel(2)}) - 0.5\Delta f_1$
D	$200 < N_{RB,agg} \leq 300$	3	$0.05 \max(BW_{Channel(1)}, BW_{Channel(2)}, BW_{Channel(3)}) - 0.5\Delta f_1$
E	$300 < N_{RB,agg} \leq 400$	4	NOTE 3
F	$400 < N_{RB,agg} \leq 500$	5	NOTE 3
NOTE 1: $BW_{Channel(j)}$, $j = 1, 2, 3$, is the channel bandwidth of an E-UTRA component carrier according to Table 5.6-1 and $\Delta f_1 = \Delta f$ for the downlink with Δf the subcarrier spacing while $\Delta f_1 = 0$ for the uplink.			
NOTE 2: $a_1 = 0.16/1.4$ for $BW_{Channel(1)} = 1.4$ MHz whereas $a_1 = 0.05$ for all other channel bandwidths.			
NOTE 3: Applicable for later releases.			

The channel spacing between centre frequencies of contiguously aggregated component carriers is defined in subclause 5.7.1A.

5.6A.1 Channel bandwidths per operating band for CA

The requirements for carrier aggregation in this specification are defined for carrier aggregation configurations with associated bandwidth combination sets. For inter-band carrier aggregation, a *carrier aggregation configuration* is a combination of operating bands, each supporting a carrier aggregation bandwidth class. For intra-band contiguous carrier aggregation, a carrier aggregation configuration is a single operating band supporting a carrier aggregation bandwidth class.

For each carrier aggregation configuration, requirements are specified for all bandwidth combinations contained in a *bandwidth combination set*, which is indicated per supported band combination in the UE radio access capability. A UE can indicate support of several bandwidth combination sets per band combination.

Requirements for intra-band contiguous carrier aggregation are defined for the carrier aggregation configurations and bandwidth combination sets specified in Table 5.6A.1-1. Requirements for inter-band carrier aggregation are defined for the carrier aggregation configurations and bandwidth combination sets specified in Table 5.6A.1-2 and Table 5.6A.1-2a. Requirements for intra-band non-contiguous carrier aggregation are defined for the carrier aggregation configurations and bandwidth combination sets specified in Table 5.6A.1-3.

The DL component carrier combinations for a given CA configuration shall be symmetrical in relation to channel centre unless stated otherwise in Table 5.6A.1-1, Table 5.6A.1-2 and Table 5.6A.1-2a.

Table 5.6A.1-1: E-UTRA CA configurations and bandwidth combination sets defined for intra-band contiguous CA

E-UTRA CA configuration / Bandwidth combination set						
E-UTRA CA configuration	Uplink CA configurations (NOTE 3)	Component carriers in order of increasing carrier frequency			Maximum aggregated bandwidth [MHz]	Bandwidth combination set
		Channel bandwidths for carrier [MHz]	Channel bandwidths for carrier [MHz]	Channel bandwidths for carrier [MHz]		
CA_1C	CA_1C	15	15		40	0
		20	20			
CA_2C		5	20		40	0
		10	15, 20			
		15	10, 15, 20			
		20	5, 10, 15, 20			
CA_3C	CA_3C	5, 10, 15	20		40	0
		20	5, 10, 15, 20			
CA_7C	CA_7C	15	15		40	0
		20	20			
		10	20		40	1
		15	15, 20			
		20	10, 15, 20			
CA_12B	-	5	5, 10		15	0
CA_23B	-	10	10		20	0
		5	15			
CA_27B	-	1.4, 3, 5	5		13	0
		1.4, 3	10			
CA_38C	CA_38C	15	15		40	0
		20	20			
CA_39C	CA_39C	5,10,15	20		35	0
		20	5, 10, 15			
CA_40C	CA_40C	10	20		40	0
		15	15			
		20	10, 20			
		10, 15	20		40	1
		15	15			
		20	10, 15, 20			
CA_40D	CA_40C	10, 15, 20	20	20	60	0
		20	10, 15	20		
		20	20	10, 15		
CA_41C	CA_41C	10	20		40	0
		15	15, 20			
		20	10, 15, 20			
		5, 10	20		40	1
		15	15, 20			
		20	5, 10, 15, 20			
		10	15, 20			

		15	10, 15, 20			
		20	10, 15, 20			
CA_41D	CA_41C	10	20	15	60	0
		10	15, 20	20		
		15	20	10, 15		
		15	10, 15, 20	20		
		20	15, 20	10		
		20	10, 15, 20	15, 20		
CA_42C	CA_42C	5, 10, 15, 20	20		40	0
		20	5, 10, 15			

NOTE 1: The CA configuration refers to an operating band and a CA bandwidth class specified in Table 5.6A-1 (the indexing letter). Absence of a CA bandwidth class for an operating band implies support of all classes.

NOTE 2: For the supported CC bandwidth combinations, the CC downlink and uplink bandwidths are equal.

NOTE 3: Uplink CA configurations are the configurations supported by the present release of specifications.

Table 5.6A.1-2: E-UTRA CA configurations and bandwidth combination sets defined for inter-band CA (two bands)

E-UTRA CA configuration / Bandwidth combination set										
E-UTRA CA Configuration	Uplink CA configurations (NOTE 4)	E-UTRA Bands	1.4 MHz	3 MHz	5 MHz	10 MHz	15 MHz	20 MHz	Maximum aggregated bandwidth [MHz]	Bandwidth combination set
CA_1A-3A	CA_1A-3A	1			Yes	Yes	Yes	Yes	40	0
		3			Yes	Yes	Yes	Yes		
CA_1A-5A	CA_1A-5A	1				Yes			20	0
		5				Yes				
		1			Yes	Yes	Yes	Yes	30	1
		5			Yes	Yes				
CA_1A-7A	CA_1A-7A	1			Yes	Yes	Yes	Yes	40	0
		7				Yes	Yes	Yes		
CA_1A-8A	CA_1A-8A	1			Yes	Yes	Yes	Yes	30	0
		8			Yes	Yes				
		1			Yes	Yes			20	1
		8			Yes	Yes				
		1			Yes	Yes	Yes	Yes	30	2
		8		Yes	Yes	Yes				
CA_1A-11A	-	1			Yes	Yes	Yes	Yes	30	0
		11			Yes	Yes				
CA_1A-18A	-	1			Yes	Yes	Yes	Yes	35	0
		18			Yes	Yes	Yes			
		1			Yes	Yes			20	1
		18			Yes	Yes				
CA_1A-19A	CA_1A-19A	1			Yes	Yes	Yes	Yes	35	0
		19			Yes	Yes	Yes			
CA_1A-20A	-	1			Yes	Yes	Yes	Yes	40	0
		20			Yes	Yes	Yes	Yes		
CA_1A-21A	CA_1A-21A	1			Yes	Yes	Yes	Yes	35	0
		21			Yes	Yes	Yes			
CA_1A-26A	-	1			Yes	Yes	Yes	Yes	35	0
		26			Yes	Yes	Yes			
		1			Yes	Yes			20	1
		26			Yes	Yes				
CA_1A-28A	-	1			Yes	Yes	Yes	Yes	40	0
		28 ⁵			Yes	Yes	Yes	Yes		
		1			Yes	Yes			20	1
		28 ⁵			Yes	Yes				
CA_1A-41A ⁵	-	1			Yes	Yes	Yes	Yes	40	0
		41			Yes	Yes	Yes	Yes		
CA_1A-41C ⁵	-	1			Yes	Yes	Yes	Yes	60	0
41	See CA_41C Bandwidth Combination Set 1 in Table 5.6.A.1-1									
CA_1A-42A	-	1			Yes	Yes	Yes	Yes	40	0
		42			Yes	Yes	Yes	Yes		
CA_1A-42C	-	1			Yes	Yes	Yes	Yes	60	0
		42	See CA_42C Bandwidth Combination Set 0 in Table 5.6A.1-1							
CA_2A-4A	CA_2A-4A	2	Yes	Yes	Yes	Yes	Yes	Yes	40	0
		4			Yes	Yes	Yes	Yes		
		2			Yes	Yes			20	1
		4			Yes	Yes				
		2			Yes	Yes	Yes	Yes	40	2
		4			Yes	Yes	Yes	Yes		
CA_2A-4A-4A	-	2			Yes	Yes	Yes	Yes	60	0
4	See CA_4A-4A Bandwidth Combination Set 0 in Table 5.6A.1-3									
CA_2A-5A	-	2			Yes	Yes	Yes	Yes	30	0

		5			Yes	Yes				
		2			Yes	Yes			20	1
		5			Yes	Yes				
CA_2A-2A-5A	-	2	See CA_2A-2A Bandwidth Combination Set 0 in Table 5.6A.1-3						50	0
		5			Yes	Yes				
CA_2A-12A	-	2			Yes	Yes	Yes	Yes	30	0
		12			Yes	Yes				
		2			Yes	Yes	Yes	Yes	30	1
		12		Yes	Yes	Yes				
CA_2A-12B	-	2			Yes	Yes	Yes	Yes	35	0
		12	See CA_12B Bandwidth Combination Set 0 in Table 5.6A.1-1							
CA_2A-13A	CA_2A-13A	2			Yes	Yes	Yes	Yes	30	0
		13				Yes				
		2			Yes	Yes			20	1
		13				Yes				
CA_2A-2A-13A	-	2	See CA_2A-2A Bandwidth Combination Set 0 in Table 5.6A.1-3						50	0
		13				Yes				
CA_2A-17A	-	2			Yes	Yes			20	0
		17			Yes	Yes				
CA_2A-29A	-	2			Yes	Yes			20	0
		29		Yes	Yes	Yes				
		2			Yes	Yes			20	1
		29			Yes	Yes				
		2			Yes	Yes	Yes	Yes	30	2
		29			Yes	Yes	Yes			
CA_2C-29A	-	2	See CA_2C Bandwidth Combination Set 0 in table 5.6A.1-1						50	0
		29			Yes	Yes				
CA_2A-30A	-	2			Yes	Yes	Yes	Yes	30	0
		30			Yes	Yes				
CA_3A-5A	CA_3A-5A	3				Yes	Yes	Yes	30	0
		5			Yes	Yes				
		3				Yes			20	1
		5			Yes	Yes				
		3			Yes	Yes	Yes	Yes	30	2
		5			Yes	Yes				
CA_3A-7A	CA_3A-7A	3			Yes	Yes	Yes	Yes	40	0
		7				Yes	Yes	Yes		
CA_3A-7C	-	3			Yes	Yes	Yes	Yes	60	0
		7	See CA_7C Bandwidth combination set 1 in table 5.6A.1-1							
CA_3C-7A	-	3	See CA_3C Bandwidth Combination Set 0 in table 5.6A.1-1						60	0
		7			Yes	Yes	Yes	Yes		
CA_3A-8A	CA_3A-8A	3				Yes	Yes	Yes	30	0
		8			Yes	Yes				
		3				Yes			20	1
		8			Yes	Yes				
		3			Yes	Yes	Yes	Yes	30	2
		8		Yes	Yes	Yes				
CA_3A-19A	CA_3A-19A	3			Yes	Yes	Yes	Yes	35	0
		19			Yes	Yes	Yes			
CA_3A-20A	CA_3A-20A	3			Yes	Yes	Yes	Yes	30	0
		20			Yes	Yes				
		3			Yes	Yes	Yes	Yes	40	1
		20			Yes	Yes	Yes	Yes		
CA_3A-26A	CA_3A-26A	3			Yes	Yes	Yes	Yes	35	0
		26			Yes	Yes	Yes			
		3			Yes	Yes			20	1

		26			Yes	Yes				
CA_3A-27A	-	3			Yes	Yes	Yes	Yes	30	0
		27			Yes	Yes				
CA_3A-28A	-	3			Yes	Yes	Yes	Yes	40	0
		28			Yes	Yes	Yes	Yes		
CA_3A-42A	-	3 ⁵			Yes	Yes	Yes	Yes	40	0
		42			Yes	Yes	Yes	Yes		
CA_3A-42C	-	3 ³			Yes	Yes	Yes	Yes	60	0
		42	See Table 5.6A.1-1							
CA_4A-5A	-	4			Yes	Yes			20	0
		5			Yes	Yes				
		4			Yes	Yes	Yes	Yes	30	1
		5			Yes	Yes				
CA_4A-4A-5A	-	4	See CA_4A-4A Bandwidth Combination Set 0 in table 5.6A.1-3						50	0
		5			Yes	Yes				
CA_4A-7A	CA_4A-7A	4			Yes	Yes			30	0
		7			Yes	Yes	Yes	Yes		
CA_4A-4A-7A	-	4			Yes	Yes			40	0
		4			Yes	Yes				
		7			Yes	Yes	Yes	Yes		
CA_4A-12A	CA_4A-12A	4	Yes	Yes	Yes	Yes			20	0
		12 ⁵			Yes	Yes				
		4	Yes	Yes	Yes	Yes	Yes	Yes	30	1
		12 ⁵			Yes	Yes				
		4			Yes	Yes	Yes	Yes	30	2
		12 ⁵		Yes	Yes	Yes				
		4			Yes	Yes			20	3
		12 ⁵			Yes	Yes				
4			Yes	Yes	Yes	Yes	30	4		
12 ⁵			Yes	Yes						
CA_4A-4A-12A	-	4	See CA_4A-4A Bandwidth Combination Set 0 in Table 5.6A.1-3						50	0
		12 ⁵			Yes	Yes				
CA_4A-12B	-	4			Yes	Yes	Yes	Yes	35	0
		12 ⁵	See CA_12B Bandwidth Combination Set 0 in Table 5.6A.1-1							
CA_4A-13A	CA_4A-13A	4			Yes	Yes	Yes	Yes	30	0
		13				Yes				
		4			Yes	Yes			20	1
		13				Yes				
CA_4A-4A-13A	-	4	See CA_4A-4A Bandwidth Combination Set 0 in Table 5.6A.1-3						50	0
		13				Yes				
CA_4A-17A	CA_4A-17A	4			Yes	Yes			20	0
		17 ⁵			Yes	Yes				
CA_4A-27A	-	4			Yes	Yes	Yes	Yes	30	0
		27		Yes	Yes	Yes				
CA_4A-29A	-	4			Yes	Yes			20	0
		29		Yes	Yes	Yes				
		4			Yes	Yes			20	1
		29			Yes	Yes				
		4			Yes	Yes	Yes	Yes	30	2
		29			Yes	Yes				
CA_4A-30A	-	4			Yes	Yes	Yes	Yes	30	0
		30			Yes	Yes				
CA_5A-7A	CA_5A-7A	5	Yes	Yes	Yes	Yes			30	0
		7				Yes	Yes	Yes		
CA_5A-12A	CA_5A-12A	5			Yes	Yes			20	0
		12			Yes	Yes				
CA_5A-13A	-	5			Yes	Yes			20	0
		13				Yes				

CA_5A-17A	CA_5A-17A	5			Yes	Yes			20	0
		17			Yes	Yes				
CA_5A-25A	-	5			Yes	Yes			30	0
		25			Yes	Yes	Yes	Yes		
CA_5A-30A	-	5			Yes	Yes			20	0
		30			Yes	Yes				
CA_7A-8A	-	7				Yes	Yes	Yes	30	0
		8 ⁵		Yes	Yes	Yes				
CA_7A-12A	-	7			Yes	Yes	Yes	Yes	30	0
		12			Yes	Yes				
CA_7A-20A	CA_7A-20A	7				Yes	Yes	Yes	30	0
		20			Yes	Yes				
		7				Yes	Yes	Yes		
CA_7A-28A	CA_7A-28A	20			Yes	Yes	Yes	Yes	40	1
		7			Yes	Yes	Yes	Yes		
CA_7A-28A	CA_7A-28A	7			Yes	Yes	Yes	Yes	35	0
		28			Yes	Yes	Yes	Yes		
CA_8A-11A	-	8			Yes	Yes			20	0
		11			Yes	Yes				
CA_8A-20A	-	8			Yes	Yes			20	0
		20			Yes	Yes				
		8		Yes	Yes	Yes			20	1
		20			Yes	Yes				
CA_8A-40A	-	8			Yes	Yes			30	0
		40			Yes	Yes	Yes	Yes		
CA_11A-18A	-	11			Yes	Yes			25	0
		18			Yes	Yes	Yes			
CA_12A-25A	-	12			Yes	Yes			30	0
		25			Yes	Yes	Yes	Yes		
CA_12A-30A	-	12			Yes	Yes			20	0
		30			Yes	Yes				
CA_18A-28A	-	18			Yes	Yes	Yes		25	0
		28			Yes	Yes				
CA_19A-21A	CA_19A-21A	19			Yes	Yes	Yes		30	0
		21			Yes	Yes	Yes			
CA_19A-42A	-	19			Yes	Yes	Yes		35	0
		42			Yes	Yes	Yes	Yes		
CA_19A-42C	-	19			Yes	Yes	Yes		55	0
42	See CA_42C Bandwidth Combination Set 0 in Table 5.6A.1-1									
CA_20A-32A	-	20			Yes	Yes			30	0
		32			Yes	Yes	Yes	Yes		
CA_23A-29A	-	23			Yes	Yes	Yes	Yes	30	0
		29		Yes	Yes	Yes				
		23			Yes	Yes				
CA_25A-41A ⁵	-	29		Yes	Yes	Yes			20	1
		29		Yes	Yes	Yes				
CA_25A-41A ⁵	-	25			Yes	Yes	Yes	Yes	40	0
		41			Yes	Yes	Yes	Yes		
CA_25A-41C ⁵	-	25			Yes	Yes	Yes	Yes	60	0
		41	See CA_41C Bandwidth Combination Set 1 in Table 5.6A.1-1							
CA_26A-41A	-	26			Yes	Yes	Yes		35	0
		41			Yes	Yes	Yes	Yes		
CA_26A-41C	-	26			Yes	Yes	Yes		55	0
		41	See CA_41C Bandwidth Combination Set 1 in Table 5.6.A.1-1							
CA_29A-30A	-	29			Yes	Yes			20	0
		30			Yes	Yes				
CA_39A-41A	CA_39A-41A	39				Yes	Yes	Yes	40	0
		41					Yes	Yes		
CA_39A-41C	-	39			Yes	Yes	Yes		60	0
		41					Yes	Yes		

		41						Yes		
CA_39C-41A	-	39	See CA_39C Bandwidth Combination Set 0 in Table 5.6A.1-1						55	0
		41					Yes			
CA_41A-42A	-	41				Yes	Yes	Yes	40	0
		42				Yes	Yes	Yes		

NOTE 1: The CA Configuration refers to a combination of an operating band and a CA bandwidth class specified in Table 5.6A-1 (the indexing letter). Absence of a CA bandwidth class for an operating band implies support of all classes.

NOTE 2: For each band combination, all combinations of indicated bandwidths belong to the set.

NOTE 3: For the supported CC bandwidth combinations, the CC downlink and uplink bandwidths are equal.

NOTE 4: Uplink CA configurations are the configurations supported by the present release of specifications.

NOTE 5: For the corresponding CA configuration, UE may not support Pcell transmissions in this E-UTRA band.

Table 5.6A.1-2a: E-UTRA CA configurations and bandwidth combination sets defined for inter-band CA (three bands)

E-UTRA CA configuration / Bandwidth combination set										
E-UTRA CA Configuration	Uplink CA configurations (NOTE 5)	E-UTRA Bands	1.4 MHz	3 MHz	5 MHz	10 MHz	15 MHz	20 MHz	Maximum aggregated bandwidth [MHz]	Bandwidth combination set
CA_1A-3A-5A	-	1			Yes	Yes	Yes	Yes	50	0
		3			Yes	Yes	Yes	Yes		
		5			Yes	Yes				
		1			Yes	Yes			40	
		3			Yes	Yes	Yes	Yes		
5			Yes	Yes						
CA_1A-3A-8A	-	1			Yes	Yes	Yes	Yes	50	0
		3			Yes	Yes	Yes	Yes		
		8		Yes	Yes	Yes				
		1			Yes	Yes			40	
		3			Yes	Yes	Yes	Yes		
		8		Yes	Yes	Yes				
		1			Yes	Yes	Yes		40	
3			Yes	Yes	Yes					
8		Yes	Yes	Yes						
CA_1A-3A-19A	-	1			Yes	Yes	Yes	Yes	55	0
		3			Yes	Yes	Yes	Yes		
		19			Yes	Yes	Yes			
CA_1A-3A-26A	-	1			Yes	Yes	Yes	Yes	50	0
		3			Yes	Yes	Yes	Yes		
		26			Yes	Yes				
CA_1A-3A-20A	-	1			Yes	Yes	Yes	Yes	60	0
		3			Yes	Yes	Yes	Yes		
		20			Yes	Yes	Yes	Yes		
CA_1A-5A-7A	-	1			Yes	Yes			40	0
		5			Yes	Yes				
		7				Yes	Yes	Yes		
		1			Yes	Yes	Yes	Yes	50	
		5			Yes	Yes				
7				Yes	Yes	Yes				
CA_1A-7A-20A	-	1			Yes	Yes	Yes	Yes	50	0
		7				Yes	Yes	Yes		
		20			Yes	Yes				
CA_1A-18A-28A	-	1			Yes	Yes	Yes	Yes	45	0
		18			Yes	Yes	Yes			
		28			Yes	Yes				
		1			Yes	Yes	Yes	Yes	40	
		18			Yes	Yes				
28			Yes	Yes						
CA_1A-19A-21A	-	1			Yes	Yes	Yes	Yes	50	0
		19			Yes	Yes	Yes			
		21			Yes	Yes	Yes			
CA_2A-4A-5A	-	2			Yes	Yes	Yes	Yes	50	0
		4			Yes	Yes	Yes	Yes		
		5			Yes	Yes				
CA_2A-4A-12A	-	2			Yes	Yes	Yes	Yes	50	0
		4			Yes	Yes	Yes	Yes		
		12			Yes	Yes				
CA_2A-4A-13A	-	2			Yes	Yes	Yes	Yes	50	0
		4			Yes	Yes	Yes	Yes		
		13				Yes				
CA_2A-4A-29A	-	2			Yes	Yes	Yes	Yes	50	0
		4			Yes	Yes	Yes	Yes		
		29			Yes	Yes				
CA_2A-5A-12A	-	2			Yes	Yes	Yes	Yes	40	0
		5			Yes	Yes				

		12			Yes	Yes				
CA_2A-5A-13A	-	2			Yes	Yes	Yes	Yes	40	0
		5			Yes	Yes				
		13				Yes				
CA_2A-5A-30A	-	2			Yes	Yes	Yes	Yes	40	0
		5			Yes	Yes				
		30			Yes	Yes				
CA_2A-12A-30A	-	2			Yes	Yes	Yes	Yes	40	0
		12			Yes	Yes				
		30			Yes	Yes				
CA_2A-29A-30A	-	2			Yes	Yes	Yes	Yes	40	0
		29			Yes	Yes				
		30			Yes	Yes				
CA_3A-7A-20A	-	3			Yes	Yes	Yes	Yes	60	0
		7				Yes	Yes	Yes		
		20			Yes	Yes	Yes	Yes		
CA_4A-5A-12A	-	4			Yes	Yes	Yes	Yes	40	0
		5			Yes	Yes				
		12			Yes	Yes				
CA_4A-5A-13A	-	4			Yes	Yes	Yes	Yes	40	0
		5			Yes	Yes				
		13				Yes				
CA_4A-5A-30A	-	4			Yes	Yes	Yes	Yes	40	0
		5			Yes	Yes				
		30			Yes	Yes				
CA_4A-7A-12A	-	4			Yes	Yes			40	0
		7			Yes	Yes	Yes	Yes		
		12 ⁶			Yes	Yes				
CA_4A-12A-30A	-	4			Yes	Yes	Yes	Yes	40	0
		12			Yes	Yes				
		30			Yes	Yes				
CA_4A-29A-30A	-	4			Yes	Yes	Yes	Yes	40	0
		29			Yes	Yes				
		30			Yes	Yes				
CA_7A-8A-20A	-	7				Yes	Yes	Yes	40	0
		8 ⁶		Yes	Yes	Yes				
		20			Yes	Yes				

NOTE 1: The CA Configuration refers to a combination of an operating band and a CA bandwidth class specified in Table 5.6A-1 (the indexing letter). Absence of a CA bandwidth class for an operating band implies support of all classes.

NOTE 2: For each band combination, all combinations of indicated bandwidths belong to the set.

NOTE 3: For the supported CC bandwidth combinations, the CC downlink and uplink bandwidths are equal.

NOTE 4: A terminal which supports a DL CA configuration shall support all the lower order fallback DL CA combinations and it shall support at least one bandwidth combination set for each of the constituent lower order DL combinations containing all the bandwidths specified within each specific combination set of the upper order DL combination.

NOTE 5: Uplink CA configurations are the configurations supported by the present release of specifications.

NOTE 6: For the corresponding CA configuration, UE may not support Pcell transmissions in this E-UTRA band.

Table 5.6A.1-3: E-UTRA CA configurations and bandwidth combination sets defined for non-contiguous intra-band CA (with two sub-blocks)

E-UTRA CA configuration / Bandwidth combination set						
E-UTRACA configuration	Uplink CA configurations (NOTE 1)	Component carriers in order of increasing carrier frequency			Maximum aggregated bandwidth [MHz]	Bandwidth combination set
		Channel bandwidths for carrier [MHz]	Channel bandwidths for carrier [MHz]	Channel bandwidths for carrier [MHz]		
CA_2A-2A	-	5, 10, 15, 20	5, 10, 15, 20		40	0
CA_3A-3A	-	5, 10, 15, 20	5, 10, 15, 20		40	0
CA_4A-4A	CA_4A-4A	5, 10, 15, 20	5, 10, 15, 20		40	0
CA_7A-7A	-	5	15		40	0
		10	10, 15			
		15	15, 20			
		20	20			
CA_23A-23A	-	5	10		15	0
CA_25A-25A	-	5, 10	5, 10		20	0
		5, 10, 15, 20	5, 10, 15, 20		40	1
CA_41A-41A	-	10, 15, 20	10, 15, 20		40	0
		5, 10, 15, 20	5, 10, 15, 20		40	1
CA_41A-41C	-	5, 10, 15, 20	See CA_41C Bandwidth Combination Set 1 in Table 5.6A.1-1		60	0
		See CA_41C Bandwidth Combination Set 1 in Table 5.6A.1-1		5, 10, 15, 20		
CA_42A-42A	-	5, 10, 15, 20	5, 10, 15, 20		40	0

NOTE 1: Uplink CA configurations are the configurations supported by the present release of specifications.

5.6B Channel bandwidth for UL-MIMO

The requirements specified in subclause 5.6 are applicable to UE supporting UL-MIMO.

5.6B.1 Void

5.6C Channel bandwidth for Dual Connectivity

For E-UTRA DC bands specified in 5.5C, the corresponding E-UTRA CA configurations in 5.6A.1, i.e., dual uplink inter-band carrier aggregation with uplink assigned to two E-UTRA bands, are applicable to Dual Connectivity.

NOTE 1: Requirements for the dual connectivity configurations are defined in the sections corresponding E-UTRA uplink CA configurations, unless otherwise specified.

NOTE 2: For TDD inter-band dual connectivity configurations, requirements are applicable only for synchronous operation. 5.6C.1 Void

5.6D Channel bandwidth for ProSe

5.6D.1 Channel bandwidths per operating band for ProSe

The ProSe combination of channel bandwidths and operating bands is shown in Table 5.6D.1-1 and Table 5.6D.1-2. The transmission bandwidth configuration in Table 5.6D.1-1 and Table 5.6D.1-2 shall be supported for each of the specified channel bandwidths. The same (symmetrical) channel bandwidth is specified for both the TX and RX path.

Table 5.6D.1-1 ProSe Direct Discovery channel bandwidth

E-UTRA ProSe band / ProSe channel bandwidth						
E-UTRA ProSe Band	1.4 MHz	3 MHz	5 MHz	10 MHz	15 MHz	20 MHz
2			Yes	Yes	Yes	Yes
3			Yes	Yes	Yes	Yes
4			Yes	Yes	Yes	Yes
7			Yes	Yes	Yes	Yes
14			Yes	Yes		
20			Yes	Yes	Yes	Yes
26			Yes	Yes	Yes	
28			Yes	Yes	Yes	Yes
31			Yes			
41			Yes	Yes	Yes	Yes

Table 5.6D.1-2 ProSe Direct Communication channel bandwidth

E-UTRA ProSe band / ProSe channel bandwidth						
E-UTRA ProSe Band	1.4 MHz	3 MHz	5 MHz	10 MHz	15 MHz	20 MHz
3				Yes		
7				Yes		
14				Yes		
20				Yes		
26				Yes		
28				Yes		
31			Yes			

5.7 Channel arrangement

5.7.1 Channel spacing

The spacing between carriers will depend on the deployment scenario, the size of the frequency block available and the channel bandwidths. The nominal channel spacing between two adjacent E-UTRA carriers is defined as following:

$$\text{Nominal Channel spacing} = (\text{BW}_{\text{Channel}(1)} + \text{BW}_{\text{Channel}(2)})/2$$

where $\text{BW}_{\text{Channel}(1)}$ and $\text{BW}_{\text{Channel}(2)}$ are the channel bandwidths of the two respective E-UTRA carriers. The channel spacing can be adjusted to optimize performance in a particular deployment scenario.

5.7.1A Channel spacing for CA

For intra-band contiguous carrier aggregation with two or more component carriers, the nominal channel spacing between two adjacent E-UTRA component carriers is defined as the following:

$$\text{Nominal channel spacing} = \left\lceil \frac{BW_{\text{Channel}(1)} + BW_{\text{Channel}(2)} - 0.1|BW_{\text{Channel}(1)} - BW_{\text{Channel}(2)}|}{0.6} \right\rceil 0.3 \text{ [MHz]}$$

where $BW_{\text{Channel}(1)}$ and $BW_{\text{Channel}(2)}$ are the channel bandwidths of the two respective E-UTRA component carriers according to Table 5.6-1 with values in MHz. The channel spacing for intra-band contiguous carrier aggregation can be adjusted to any multiple of 300 kHz less than the nominal channel spacing to optimize performance in a particular deployment scenario.

For intra-band non-contiguous carrier aggregation the channel spacing between two E-UTRA component carriers in different sub-blocks shall be larger than the nominal channel spacing defined in this subclause.

5.7.2 Channel raster

The channel raster is 100 kHz for all bands, which means that the carrier centre frequency must be an integer multiple of 100 kHz.

5.7.2A Channel raster for CA

For carrier aggregation the channel raster is 100 kHz for all bands, which means that the carrier centre frequency must be an integer multiple of 100 kHz.

5.7.3 Carrier frequency and EARFCN

The carrier frequency in the uplink and downlink is designated by the E-UTRA Absolute Radio Frequency Channel Number (EARFCN) in the range 0 – 65535. The relation between EARFCN and the carrier frequency in MHz for the downlink is given by the following equation, where $F_{\text{DL_low}}$ and $N_{\text{Offs-DL}}$ are given in Table 5.7.3-1 and N_{DL} is the downlink EARFCN.

$$F_{\text{DL}} = F_{\text{DL_low}} + 0.1(N_{\text{DL}} - N_{\text{Offs-DL}})$$

The relation between EARFCN and the carrier frequency in MHz for the uplink is given by the following equation where $F_{\text{UL_low}}$ and $N_{\text{Offs-UL}}$ are given in Table 5.7.3-1 and N_{UL} is the uplink EARFCN.

$$F_{\text{UL}} = F_{\text{UL_low}} + 0.1(N_{\text{UL}} - N_{\text{Offs-UL}})$$

Table 5.7.3-1: E-UTRA channel numbers

E-UTRA Operating Band	Downlink			Uplink		
	F _{DL_low} (MHz)	N _{Offs-DL}	Range of N _{DL}	F _{UL_low} (MHz)	N _{Offs-UL}	Range of N _{UL}
1	2110	0	0 – 599	1920	18000	18000 – 18599
2	1930	600	600 – 1199	1850	18600	18600 – 19199
3	1805	1200	1200 – 1949	1710	19200	19200 – 19949
4	2110	1950	1950 – 2399	1710	19950	19950 – 20399
5	869	2400	2400 – 2649	824	20400	20400 – 20649
6	875	2650	2650 – 2749	830	20650	20650 – 20749
7	2620	2750	2750 – 3449	2500	20750	20750 – 21449
8	925	3450	3450 – 3799	880	21450	21450 – 21799
9	1844.9	3800	3800 – 4149	1749.9	21800	21800 – 22149
10	2110	4150	4150 – 4749	1710	22150	22150 – 22749
11	1475.9	4750	4750 – 4949	1427.9	22750	22750 – 22949
12	729	5010	5010 – 5179	699	23010	23010 – 23179
13	746	5180	5180 – 5279	777	23180	23180 – 23279
14	758	5280	5280 – 5379	788	23280	23280 – 23379
...						
17	734	5730	5730 – 5849	704	23730	23730 – 23849
18	860	5850	5850 – 5999	815	23850	23850 – 23999
19	875	6000	6000 – 6149	830	24000	24000 – 24149
20	791	6150	6150 – 6449	832	24150	24150 – 24449
21	1495.9	6450	6450 – 6599	1447.9	24450	24450 – 24599
22	3510	6600	6600 – 7399	3410	24600	24600 – 25399
23	2180	7500	7500 – 7699	2000	25500	25500 – 25699
24	1525	7700	7700 – 8039	1626.5	25700	25700 – 26039
25	1930	8040	8040 – 8689	1850	26040	26040 – 26689
26	859	8690	8690 – 9039	814	26690	26690 – 27039
27	852	9040	9040 – 9209	807	27040	27040 – 27209
28	758	9210	9210 – 9659	703	27210	27210 – 27659
29 ²	717	9660	9660 – 9769	N/A		
30	2350	9770	9770 – 9869	2305	27660	27660 – 27759
31	462.5	9870	9870 – 9919	452.5	27760	27760 – 27809
...32 ²	1452	9920	9920 – 10359	N/A		
33	1900	36000	36000 – 36199	1900	36000	36000 – 36199
34	2010	36200	36200 – 36349	2010	36200	36200 – 36349
35	1850	36350	36350 – 36949	1850	36350	36350 – 36949
36	1930	36950	36950 – 37549	1930	36950	36950 – 37549
37	1910	37550	37550 – 37749	1910	37550	37550 – 37749
38	2570	37750	37750 – 38249	2570	37750	37750 – 38249
39	1880	38250	38250 – 38649	1880	38250	38250 – 38649
40	2300	38650	38650 – 39649	2300	38650	38650 – 39649
41	2496	39650	39650 – 41589	2496	39650	39650 – 41589
42	3400	41590	41590 – 43589	3400	41590	41590 – 43589
43	3600	43590	43590 – 45589	3600	43590	43590 – 45589
44	703	45590	45590 – 46589	703	45590	45590 – 46589

NOTE 1: The channel numbers that designate carrier frequencies so close to the operating band edges that the carrier extends beyond the operating band edge shall not be used. This implies that the first 7, 15, 25, 50, 75 and 100 channel numbers at the lower operating band edge and the last 6, 14, 24, 49, 74 and 99 channel numbers at the upper operating band edge shall not be used for channel bandwidths of 1.4, 3, 5, 10, 15 and 20 MHz respectively.

NOTE 2: Restricted to E-UTRA operation when carrier aggregation is configured.

NOTE 3: For ProSe the corresponding UL channel number are also specified for the DL for the associated ProSe operating bands i.e. ProSe_F_{UL} = F_{UL} and ProSe_F_{DL} = F_{UL}.

5.7.4 TX–RX frequency separation

a) The default E-UTRA TX channel (carrier centre frequency) to RX channel (carrier centre frequency) separation is specified in Table 5.7.4-1 for the TX and RX channel bandwidths defined in Table 5.6.1-1

Table 5.7.4-1: Default UE TX-RX frequency separation

E-UTRA Operating Band	TX – RX carrier centre frequency separation
1	190 MHz
2	80 MHz.
3	95 MHz.
4	400 MHz
5	45 MHz
6	45 MHz
7	120 MHz
8	45 MHz
9	95 MHz
10	400 MHz
11	48 MHz
12	30 MHz
13	-31 MHz
14	-30 MHz
17	30 MHz
18	45 MHz
19	45 MHz
20	-41 MHz
21	48 MHz
22	100 MHz
23	180 MHz
24	-101.5, -120.5 MHz
25	80 MHz
26	45 MHz
27	45 MHz
28	55 MHz
30	45 MHz
31	10 MHz

b) The use of other TX channel to RX channel carrier centre frequency separation is not precluded and is intended to form part of a later release.

5.7.4A TX–RX frequency separation for CA

For intra-band contiguous carrier aggregation, the same TX-RX frequency separation as specified in Table 5.7.4-1 is applied to PCC and SCC, respectively.

6 Transmitter characteristics

6.1 General

Unless otherwise stated, the transmitter characteristics are specified at the antenna connector of the UE with a single or multiple transmit antenna(s). For UE with integral antenna only, a reference antenna with a gain of 0 dBi is assumed.

6.2 Transmit power

6.2.1 Void

6.2.2 UE maximum output power

The following UE Power Classes define the maximum output power for any transmission bandwidth within the channel bandwidth for non CA configuration unless otherwise stated. The period of measurement shall be at least one sub frame (1ms).

Table 6.2.2-1: UE Power Class

EUTRA band	Class 1 (dBm)	Tolerance (dB)	Class 2 (dBm)	Tolerance (dB)	Class 3 (dBm)	Tolerance (dB)	Class 4 (dBm)	Tolerance (dB)
1					23	± 2		
2					23	$\pm 2^2$		
3					23	$\pm 2^2$		
4					23	± 2		
5					23	± 2		
6					23	± 2		
7					23	$\pm 2^2$		
8					23	$\pm 2^2$		
9					23	± 2		
10					23	± 2		
11					23	± 2		
12					23	$\pm 2^2$		
13					23	± 2		
14	31	+2/-3			23	± 2		
17					23	± 2		
18					23	$\pm 2^5$		
19					23	± 2		
20					23	$\pm 2^2$		
21					23	± 2		
22					23	+2/-3.5 ²		
23					23 ⁶	$\pm 2^6$		
24					23	+2/-3 ²		
25					23	$\pm 2^2$		
26					23	$\pm 2^2$		
27					23	± 2		
28					23	+2/-2.5		
30					23	± 2		
31					23	± 2		
...								
33					23	± 2		
34					23	± 2		
35					23	± 2		
36					23	± 2		
37					23	± 2		
38					23	± 2		
39					23	± 2		
40					23	± 2		
41					23	$\pm 2^2$		
42					23	+2/-3		
43					23	+2/-3		
44					23	+2/[-3]		
<p>NOTE 1: Void</p> <p>NOTE 2: ² refers to the transmission bandwidths (Figure 5.6-1) confined within F_{UL_low} and $F_{UL_low} + 4$ MHz or $F_{UL_high} - 4$ MHz and F_{UL_high}, the maximum output power requirement is relaxed by reducing the lower tolerance limit by 1.5 dB</p> <p>NOTE 3: For the UE which supports both Band 11 and Band 21 operating frequencies, the tolerance is FFS.</p> <p>NOTE 4: $P_{PowerClass}$ is the maximum UE power specified without taking into account the tolerance</p> <p>NOTE 5: For a UE that supports both Band 18 and Band 26, the maximum output power requirement is relaxed by reducing the lower tolerance limit by 1.5 dB for transmission bandwidths confined within 815 MHz and 818 MHz.</p> <p>NOTE 6: When NS_20 is signalled, the total output power within 2000-2005 MHz shall be limited to 7 dBm.</p>								

6.2.2A UE maximum output power for CA

The following UE Power Classes define the maximum output power for any transmission bandwidth within the aggregated channel bandwidth.

The maximum output power is measured as the sum of the maximum output power at each UE antenna connector. The period of measurement shall be at least one sub frame (1ms).

For inter-band carrier aggregation with uplink assigned to one E-UTRA band the requirements in subclause 6.2.2 apply.

For inter-band carrier aggregation with uplink assigned to two E-UTRA bands, UE maximum output power shall be measured over all component carriers from different bands. If each band has separate antenna connectors, maximum output power is measured as the sum of maximum output power at each UE antenna connector. The maximum output power is specified in Table 6.2.2A-0.

Table 6.2.2A-0: UE Power Class for uplink interband CA (two bands)

E-UTRA CA Configuration	Class 1 (dBm)	Tolerance (dB)	Class 2 (dBm)	Tolerance (dB)	Class 3 (dBm)	Tolerance (dB)	Class 4 (dBm)	Tolerance (dB)
CA_1A-3A					23	+2/-3 ²		
CA_1A-5A					23	+2/-3		
CA_1A-7A					23	+2/-3 ²		
CA_1A-8A					23	+2/-3 ²		
CA_1A-19A					23	+2/-3		
CA_1A-21A					23	+2/-3		
CA_2A-4A					23	+2/-3 ²		
CA_2A-13A					23	+2/-3 ²		
CA_3A-5A					23	+2/-3 ²		
CA_3A-7A					23	+2/-3 ²		
CA_3A-8A					23	+2/-3 ²		
CA_3A-19A					23	+2/-3 ²		
CA_3A-20A					23	+2/-3 ²		
CA_3A-26A					23	+2/-3 ²		
CA_4A-7A					23	+2/-3 ²		
CA_4A-12A					23	+2/-3 ²		
CA_4A-13A					23	+2/-3		
CA_4A-17A					23	+2/-3		
CA_5A-7A					23	+2/-3 ²		
CA_5A-12A					23	+2/-3 ²		
CA_5A-17A					23	+2/-3		
CA_7A-20A					23	+2/-3 ²		
CA_7A-28A					23	+2/-3 ²		
CA_19A-21A					23	+2/-3		
CA_39A-41A					23	+2/-3 ²		

NOTE 1: Void
NOTE 2: ² refers to the transmission bandwidths (Figure 5.6-1) confined within F_{UL_low} and $F_{UL_low} + 4$ MHz or $F_{UL_high} - 4$ MHz and F_{UL_high} , the maximum output power requirement is relaxed by reducing the lower tolerance limit by 1.5 dB
NOTE 3: $P_{PowerClass}$ is the maximum UE power specified without taking into account the tolerance
NOTE 4: For inter-band carrier aggregation the maximum power requirement should apply to the total transmitted power over all component carriers (per UE).

For intra-band contiguous carrier aggregation the maximum output power is specified in Table 6.2.2A-1.

Table 6.2.2A-1: CA UE Power Class for intraband contiguous CA

E-UTRA CA Configuration	Class 1 (dBm)	Tolerance (dB)	Class 2 (dBm)	Tolerance (dB)	Class 3 (dBm)	Tolerance (dB)	Class 4 (dBm)	Tolerance (dB)
CA_1C					23	+2/-2		
CA_3C					23	+2/-2 ²		
CA_7C					23	+2/-2 ²		
CA_38C					23	+2/-2		
CA_39C					23	+2/-2		
CA_40C					23	+2/-2		
CA_41C					23	+2/-2 ²		
CA_42C					23	+2/-3		

NOTE 1: Void
NOTE 2: If all transmitted resource blocks (Figure 5.6A-1) over all component carriers are confined within F_{UL_low} and $F_{UL_low} + 4$ MHz or/and $F_{UL_high} - 4$ MHz and F_{UL_high} , the maximum output power requirement is relaxed by reducing the lower tolerance limit by 1.5 dB
NOTE 3: $P_{PowerClass}$ is the maximum UE power specified without taking into account the tolerance
NOTE 4: For intra-band contiguous carrier aggregation the maximum power requirement should apply to the total transmitted power over all component carriers (per UE).

For intra-band non-contiguous carrier aggregation with one uplink carrier on the PCC, the requirements in subclause 6.2.2 apply. For intra-band non-contiguous carrier aggregation with two uplink carriers the maximum output power is specified in Table 6.2.2A-2.

Table 6.2.2A-2: UE Power Class for intraband non-contiguous CA

E-UTRA CA Configuration	Class 1 (dBm)	Tolerance (dB)	Class 2 (dBm)	Tolerance (dB)	Class 3 (dBm)	Tolerance (dB)	Class 4 (dBm)	Tolerance (dB)
CA_4A-4A					23	+2/-2		

NOTE 1: For transmission bandwidths (Figure 5.6-1) confined within F_{UL_low} and $F_{UL_low} + 4$ MHz or $F_{UL_high} - 4$ MHz and F_{UL_high} , the maximum output power requirement is relaxed by reducing the lower tolerance limit by 1.5 dB
NOTE 2: $P_{PowerClass}$ is the maximum UE power specified without taking into account the tolerance
NOTE 3: For intra-band non-contiguous carrier aggregation the maximum power requirement should apply to the total transmitted power over all component carriers (per UE).

6.2.2B UE maximum output power for UL-MIMO

For UE with two transmit antenna connectors in closed-loop spatial multiplexing scheme, the maximum output power for any transmission bandwidth within the channel bandwidth is specified in Table 6.2.2B-1. The requirements shall be met with the UL-MIMO configurations specified in Table 6.2.2B-2. For UE supporting UL-MIMO, the maximum output power is measured as the sum of the maximum output power at each UE antenna connector. The period of measurement shall be at least one sub frame (1ms).

Table 6.2.2B-1: UE Power Class for UL-MIMO in closed loop spatial multiplexing scheme

EUTRA band	Class 1 (dBm)	Tolerance (dB)	Class 2 (dBm)	Tolerance (dB)	Class 3 (dBm)	Tolerance (dB)	Class 4 (dBm)	Tolerance (dB)
1					23	+2/-3		
2					23	+2/-3 ²		
3					23	+2/-3 ²		
4					23	+2/-3		
5					23	+2/-3		
6					23	+2/-3		
7					23	+2/-3 ²		
8					23	+2/-3 ²		
9					23	+2/-3		
10					23	+2/-3		
11					23	+2/-3		
12					23	+2/-3 ²		
13					23	+2/-3		
14					23	+2/-3		
17					23	+2/-3		
18					23	+2/-3		
19					23	+2/-3		
20					23	+2/-3 ²		
21					23	+2/-3		
22					23	+2/-4.5 ²		
...								
23					23	+2/-3		
24					23	+2/-3		
25					23	+2/-3 ²		
26					23	+2/-3 ²		
27					23	+2/-3		
28					23	+2/[-3]		
30					23	+2/-3		
31					23	+2/-3		
...								
33					23	+2/-3		
34					23	+2/-3		
35					23	+2/-3		
36					23	+2/-3		
37					23	+2/-3		
38					23	+2/-3		
39					23	+2/-3		
40					23	+2/-3		
41					23	+2/-3 ²		
42					23	+2/-4		
43					23	+2/-4		
44					23	+2/[-3]		

NOTE 1: Void
 NOTE 2: ² refers to the transmission bandwidths (Figure 5.6-1) confined within F_{UL,low} and F_{UL,low} + 4 MHz or F_{UL,high} - 4 MHz and F_{UL,high}, the maximum output power requirement is relaxed by reducing the lower tolerance limit by 1.5 dB
 NOTE 3: For the UE which supports both Band 11 and Band 21 operating frequencies, the tolerance is FFS.
 NOTE 4: P_{PowerClass} is the maximum UE power specified without taking into account the tolerance

Table 6.2.2B-2: UL-MIMO configuration in closed-loop spatial multiplexing scheme

Transmission mode	DCI format	Codebook Index
Mode 2	DCI format 4	Codebook index 0

If UE is configured for transmission on single-antenna port, the requirements in subclause 6.2.2 apply.

6.2.3 UE maximum output power for modulation / channel bandwidth

For UE Power Class 1 and 3, the allowed Maximum Power Reduction (MPR) for the maximum output power in Table 6.2.2-1 due to higher order modulation and transmit bandwidth configuration (resource blocks) is specified in Table 6.2.3-1.

Table 6.2.3-1: Maximum Power Reduction (MPR) for Power Class 1 and 3

Modulation	Channel bandwidth / Transmission bandwidth (N_{RB})						MPR (dB)
	1.4 MHz	3.0 MHz	5 MHz	10 MHz	15 MHz	20 MHz	
QPSK	> 5	> 4	> 8	> 12	> 16	> 18	≤ 1
16 QAM	≤ 5	≤ 4	≤ 8	≤ 12	≤ 16	≤ 18	≤ 1
16 QAM	> 5	> 4	> 8	> 12	> 16	> 18	≤ 2

For PRACH, PUCCH and SRS transmissions, the allowed MPR is according to that specified for PUSCH QPSK modulation for the corresponding transmission bandwidth.

For each subframe, the MPR is evaluated per slot and given by the maximum value taken over the transmission(s) within the slot; the maximum MPR over the two slots is then applied for the entire subframe.

For transmissions with non-contiguous resource allocation in single component carrier, the allowed Maximum Power Reduction (MPR) for the maximum output power in table 6.2.2-1, is specified as follows

$$MPR = \text{CEIL} \{M_A, 0.5\}$$

Where M_A is defined as follows

$$M_A = 8.00 - 10.12A \quad ; 0.00 < A \leq 0.33$$

$$5.67 - 3.07A \quad ; 0.33 < A \leq 0.77$$

$$3.31 \quad ; 0.77 < A \leq 1.00$$

Where

$$A = N_{RB_alloc} / N_{RB}$$

$\text{CEIL}\{M_A, 0.5\}$ means rounding upwards to closest 0.5dB, i.e. $MPR \in [3.0, 3.5, 4.0, 4.5, 5.0, 5.5, 6.0, 6.5, 7.0, 7.5, 8.0]$

For the UE maximum output power modified by MPR, the power limits specified in subclause 6.2.5 apply.

6.2.3A UE Maximum Output power for modulation / channel bandwidth for CA

For inter-band carrier aggregation with uplink assigned to one E-UTRA band (Table 5.6A-1), the requirements in subclause 6.2.3 apply.

For inter-band carrier aggregation with one component carrier per operating band and the uplink active in two E-UTRA bands, the requirements in subclause 6.2.3 apply for each uplink component carrier.

For intra-band contiguous carrier aggregation the allowed Maximum Power Reduction (MPR) for the maximum output power in Table 6.2.2A-1 due to higher order modulation and contiguously aggregated transmit bandwidth configuration (resource blocks) is specified in Table 6.2.3A-1. In case the modulation format is different on different component carriers then the MPR is determined by the rules applied to higher order of those modulations.

Table 6.2.3A-1: Maximum Power Reduction (MPR) for Power Class 3

Modulation	CA bandwidth Class C / Smallest Component Carrier Transmission Bandwidth Configuration				MPR (dB)
	25 RB	50 RB	75 RB	100 RB	
QPSK	> 8 and ≤ 25	> 12 and ≤ 50	> 16 and ≤ 75	> 18 and ≤ 100	≤ 1
QPSK	> 25	> 50	> 75	> 100	≤ 2
16 QAM	≤ 8	≤ 12	≤ 16	≤ 18	≤ 1
16 QAM	> 8 and ≤ 25	> 12 and ≤ 50	> 16 and ≤ 75	> 18 and ≤ 100	≤ 2
16 QAM	> 25	> 50	> 75	> 100	≤ 3

For PUCCH and SRS transmissions, the allowed MPR is according to that specified for PUSCH QPSK modulation for the corresponding transmission bandwidth.

For intra-band contiguous carrier aggregation bandwidth class C with non-contiguous resource allocation, the allowed Maximum Power Reduction (MPR) for the maximum output power in Table 6.2.2A-1 is specified as follows

$$\text{MPR} = \text{CEIL} \{ \min(M_A, M_{IM5}), 0.5 \}$$

Where M_A is defined as follows

$$\begin{aligned} M_A &= 8.2 && ; 0 \leq A < 0.025 \\ &9.2 - 40A && ; 0.025 \leq A < 0.05 \\ &8 - 16A && ; 0.05 \leq A < 0.25 \\ &4.83 - 3.33A && ; 0.25 \leq A \leq 0.4, \\ &3.83 - 0.83A && ; 0.4 \leq A \leq 1, \end{aligned}$$

and M_{IM5} is defined as follows

$$\begin{aligned} M_{IM5} &= 4.5 && ; \Delta_{IM5} < 1.5 * \text{BW}_{\text{Channel_CA}} \\ &6.0 && ; 1.5 * \text{BW}_{\text{Channel_CA}} \leq \Delta_{IM5} < \text{BW}_{\text{Channel_CA}}/2 + F_{\text{OOB}} \\ M_A &&& ; \Delta_{IM5} \geq \text{BW}_{\text{Channel_CA}}/2 + F_{\text{OOB}} \end{aligned}$$

Where

$$A = N_{\text{RB_alloc}} / N_{\text{RB_agg}}$$

$$\Delta_{IM5} = \max(|F_{\text{C_agg}} - (3 * F_{\text{agg_alloc_low}} - 2 * F_{\text{agg_alloc_high}})|, |F_{\text{C_agg}} - (3 * F_{\text{agg_alloc_high}} - 2 * F_{\text{agg_alloc_low}})|)$$

$$F_{\text{C_agg}} = (F_{\text{edge_high}} + F_{\text{edge_low}})/2$$

$\text{CEIL}\{M_A, 0.5\}$ means rounding upwards to closest 0.5dB, i.e. $\text{MPR} \in [3.0, 3.5, 4.0, 4.5, 5.0, 5.5, 6.0, 6.5, 7.0, 7.5, 8.0, 8.5]$.

For intra-band non-contiguous carrier aggregation with one uplink carrier, the requirements in subclause 6.2.3 apply.

For intra-band non-contiguous carrier aggregation with two uplink carriers MPR is specified for E-UTRA CA configurations with a maximum possible $W_{\text{GAP}} \leq 35$ MHz; the allowed MPR is

$$\text{MPR} = \text{CEIL} \{ M_N, 0.5 \}$$

where M_N is defined as follows

$$\begin{aligned} M_N &= -0.125 N + 18.25 && ; 2 \leq N \leq 50 \\ &-0.0333 N + 13.67 && ; 50 < N \leq 200 \end{aligned}$$

where $N = N_{RB_alloc}$ is the number of allocated resource blocks. Clause 6.2.3 does not apply in addition. E-UTRA CA configurations with a maximum possible $W_{gap} > 35$ MHz and their corresponding MPR are intended to form part of a later release.

For intra-band carrier aggregation, the MPR is evaluated per slot and given by the maximum value taken over the transmission(s) on all component carriers within the slot; the maximum MPR over the two slots is then applied for the entire subframe.

For the UE maximum output power modified by MPR, the power limits specified in subclause 6.2.5A apply.

6.2.3B UE maximum output power for modulation / channel bandwidth for UL-MIMO

For UE with two transmit antenna connectors in closed-loop spatial multiplexing scheme, the allowed Maximum Power Reduction (MPR) for the maximum output power in Table 6.2.2B-1 is specified in Table 6.2.3-1. The requirements shall be met with UL-MIMO configurations defined in Table 6.2.2B-2. For UE supporting UL-MIMO, the maximum output power is measured as the sum of the maximum output power at each UE antenna connector.

For the UE maximum output power modified by MPR, the power limits specified in subclause 6.2.5B apply.

If UE is configured for transmission on single-antenna port, the requirements in subclause 6.2.3 apply.

6.2.3D UE maximum output power for modulation / channel bandwidth for ProSe

For UE Power Class 1 and 3, this subclause specifies the allowed Maximum Power Reduction (MPR) power for ProSe physical channels and signals due to higher order modulation and transmit bandwidth configuration (resource blocks).

The allowed MPR for the maximum output power for ProSe physical channels PSDCH, PSCCH, PSSCH, and PSBCH shall be as specified in subclause 6.2.3 for PUSCH for the corresponding modulation and transmission bandwidth.

The allowed MPR for the maximum output power for ProSe physical signal PSSS shall be as specified in subclause 6.2.3 for PUSCH QPSK modulation for the corresponding transmission bandwidth.

The allowed MPR for the maximum output power for ProSe physical signal SSSS is specified in Table 6.2.3D-1.

Table 6.2.3D-1: Maximum Power Reduction (MPR) for SSSS for Power Class 1 and 3

Channel bandwidth	MPR for SSSS (dB)
1.4 MHz	
3.0 MHz	
5.0 MHz	≤ 4
10 MHz	≤ 4
15 MHz	≤ 4
20 MHz	≤ 4

6.2.4 UE maximum output power with additional requirements

Additional ACLR and spectrum emission requirements can be signalled by the network to indicate that the UE shall also meet additional requirements in a specific deployment scenario. To meet these additional requirements, Additional Maximum Power Reduction (A-MPR) is allowed for the output power as specified in Table 6.2.2-1. Unless stated otherwise, an A-MPR of 0 dB shall be used.

For UE Power Class 1 and 3 the specific requirements and identified subclauses are specified in Table 6.2.4-1 along with the allowed A-MPR values that may be used to meet these requirements. The allowed A-MPR values specified below in Table 6.2.4.-1 to 6.2.4-15 are in addition to the allowed MPR requirements specified in subclause 6.2.3.

Table 6.2.4-1: Additional Maximum Power Reduction (A-MPR)

Network Signalling value	Requirements (subclause)	E-UTRA Band	Channel bandwidth (MHz)	Resources Blocks (N_{RB})	A-MPR (dB)
NS_01	6.6.2.1.1	Table 5.5-1	1.4, 3, 5, 10, 15, 20	Table 5.6-1	N/A
NS_03	6.6.2.2.1	2, 4, 10, 23, 25, 35, 36	3	>5	≤ 1
			5	>6	≤ 1
			10	>6	≤ 1
			15	>8	≤ 1
			20	>10	≤ 1
NS_04	6.6.2.2.2, 6.6.3.3.19	41	5, 10, 15, 20	Table 6.2.4-4	
NS_05	6.6.3.3.1	1	10, 15, 20	≥ 50	≤ 1 (NOTE1)
			15, 20	Table 6.2.4-18 (NOTE2)	
NS_06	6.6.2.2.3	12, 13, 14, 17	1.4, 3, 5, 10	Table 5.6-1	N/A
NS_07	6.6.2.2.3 6.6.3.3.2	13	10	Table 6.2.4-2	
NS_08	6.6.3.3.3	19	10, 15	> 44	≤ 3
NS_09	6.6.3.3.4	21	10, 15	> 40	≤ 1
				> 55	≤ 2
NS_10		20	15, 20	Table 6.2.4-3	
NS_11	6.6.2.2.1	23	1.4, 3, 5, 10, 15, 20	Table 6.2.4-5	
	6.6.3.3.13				
NS_12	6.6.3.3.5	26	1.4, 3, 5, 10, 15	Table 6.2.4-6	
NS_13	6.6.3.3.6	26	5	Table 6.2.4-7	
NS_14	6.6.3.3.7	26	10, 15	Table 6.2.4-8	
NS_15	6.6.3.3.8	26	1.4, 3, 5, 10, 15	Table 6.2.4-9	
				Table 6.2.4-10	
NS_16	6.6.3.3.9	27	3, 5, 10	Table 6.2.4-11, Table 6.2.4-12, Table 6.2.4-13	
NS_17	6.6.3.3.10	28	5, 10	Table 5.6-1	N/A
NS_18	6.6.3.3.11	28	5	≥ 2	≤ 1
			10, 15, 20	≥ 1	≤ 4
NS_19	6.6.3.3.12	44	10, 15, 20	Table 6.2.4-14	
NS_20	6.2.2	23	5, 10, 15, 20	Table 6.2.4-15	
	6.6.2.2.1 6.6.3.3.14				
NS_21	6.6.2.2.1	30	5, 10	Table 6.2.4-16	
	6.6.3.3.15				
NS_22	6.6.3.3.16	42, 43	5, 10, 15, 20	Table 6.2.4-17	
NS_23	6.6.3.3.17	42, 43	5, 10, 15, 20	N/A	
...					
NS_32	-	-	-	-	-
..					
NS_56	6.6.3.3.35	24	5, 10	Table 6.2.4-34a	
NOTE 1	Applicable when the lower edge of the assigned E-UTRA UL channel bandwidth frequency is larger than or equal to the upper edge of PHS band (1915.7 MHz) + 4 MHz + the channel BW assigned, where channel BW is as defined in subclause 5.6. A-MPR for operations below this frequency is not covered in this version of specifications except for the channel assignments in NOTE 2 as the emissions requirement in 6.6.3.3.1 may not be met. For 10MHz channel bandwidth whose carrier frequency is larger than or equal to 1945 MHz or 15 MHz channel bandwidth whose carrier frequency is larger than or equal to 1947.5 MHz, no A-MPR applies.				
NOTE 2	Applicable when carrier frequency is 1932.5 MHz for 15MHz channel bandwidth or 1930 MHz for 20MHz channel bandwidth case.				

Table 6.2.4-2: A-MPR for "NS_07"

Parameters	Region A		Region B		Region C
RB _{start}	0 - 12		13 – 18	19 – 42	43 – 49
L _{CRB} [RBs]	6-8	1 to 5 and 9-50	≥8	≥18	≤2
A-MPR [dB]	≤ 8	≤ 12	≤ 12	≤ 6	≤ 3
NOTE 1; RB _{start} indicates the lowest RB index of transmitted resource blocks NOTE 2; L _{CRB} is the length of a contiguous resource block allocation NOTE 3: For intra-subframe frequency hopping between two regions, notes 1 and 2 apply on a per slot basis. NOTE 4; For intra-subframe frequency hopping between two regions, the larger A-MPR value of the two regions may be applied for both slots in the subframe.					

Table 6.2.4-3: A-MPR for "NS_10"

Channel bandwidth [MHz]	Parameters	Region A
15	RB _{start}	0 – 10
	L _{CRB} [RBs]	1 -20
	A-MPR [dB]	≤ 2
20	RB _{start}	0 – 15
	L _{CRB} [RBs]	1 -20
	A-MPR [dB]	≤ 5
NOTE 1: RB _{start} indicates the lowest RB index of transmitted resource blocks NOTE 2: L _{CRB} is the length of a contiguous resource block allocation NOTE 3: For intra-subframe frequency hopping which intersects Region A, notes 1 and 2 apply on a per slot basis NOTE 4: For intra-subframe frequency hopping which intersect Region A, the larger A-MPR value may be applied for both slots in the subframe		

Table 6.2.4-4: A-MPR requirements for "NS_04" with bandwidth >5MHz

Channel bandwidth [MHz]	Parameters						
5	Fc [MHz]	≤ 2499.5				> 2499.5	
	RB _{start}	0 - 8		9 - 24		0 - 24	
	LCRB [RBs]	> 0		> 0		> 0	
	A-MPR [dB]	≤ 2		0		0	
10	Fc [MHz]	≤ 2504				> 2504	
	RB _{start}	0 - 8		9 - 35	36 - 49	0 - 49	
	LCRB [RBs]	≤ 15	> 15 and < 25	≥ 25	N/A	> 0	> 0
	RB _{start} + LCRB [RBs]	N/A	N/A	N/A	≥ 45	N/A	N/A
	A-MPR [dB]	≤ 3	≤ 1	≤ 2	≤ 1	0	0
15	Fc [MHz]	≤ 2510.8				> 2510.8	
	RB _{start}	0 - 13		14 - 59	60 - 74	0 - 74	
	LCRB [RBs]	≤ 18 or ≥ 36	> 18 and < 36	N/A	> 0	> 0	
	RB _{start} + LCRB [RBs]	N/A	N/A	≥ 62	N/A	N/A	
A-MPR [dB]	≤ 3	≤ 1	≤ 1	≤ 1	0	0	
20	Fc [MHz]	≤ 2517.5				> 2517.5	
	RB _{start}	0 - 22		23 - 76	77 - 99	0 - 99	
	LCRB [RBs]	≤ 18 or ≥ 40	> 18 and < 40	N/A	> 0	> 0	
	RB _{start} + LCRB [RBs]	N/A	N/A	≥ 86	N/A	N/A	
A-MPR [dB]	≤ 3	≤ 1	≤ 1	≤ 1	0	0	
NOTE 1: RB _{start} indicates the lowest RB index of transmitted resource blocks							
NOTE 2: LCRB is the length of a contiguous resource block allocation							
NOTE 3: For intra-subframe frequency hopping which intersects regions, notes 1 and 2 apply on a per slot basis							
NOTE 4: For intra-subframe frequency hopping which intersects regions, the larger A-MPR value may be applied for both slots in the subframe							

Table 6.2.4-5: A-MPR for "NS_11"

Channel Bandwidth [MHz]	Parameters						
3	F _c [MHz]	<2004		≥2004			
	L _{CRB} [RBs]	1-15		>5			
	A-MPR [dB]	≤5		≤1			
5	F _c [MHz]	<2004		2004 ≤ F _c <2007		≥2007	
	L _{CRB} [RBs]	1-25		1-6 & 15-25	8-12	>6	
	A-MPR [dB]	≤7		≤4	0	≤1	
10	F _c [MHz]	2005 ≤ F _c <2015			2015		
	RB _{start}	0-49			0-49		
	L _{CRB} [RBs]	1-50			1-50		
	A-MPR [dB]	≤12			0		
15	F _c [MHz]	<2012.5					
	RB _{start}	0-4	5-21		22-56		57-74
	L _{CRB} [RBs]	≥1	7-50	0-6 & ≥50	≤25	>25	>0
	A-MPR [dB]	≤15	≤7	≤10	0	≤6	≤15
	F _c [MHz]	2012.5					
	RB _{start}	0-12	13-39		40-65		66-74
	L _{CRB} [RBs]	≥1	≥30	<30	≥ (69 – RB _{start})		≥1
A-MPR [dB]	≤10	≤6	0	≤2		≤6.5	
20	F _c [MHz]	2010					
	RB _{start}	0-12	13-29		30-68		69-99
	L _{CRB} [RBs]	≥1	10-60	1-9 & >60	1-24	≥25	≥1
	A-MPR [dB]	≤15	≤7	≤10	0	≤7	≤15

Table 6.2.4-6: A-MPR for "NS_12"

Channel bandwidth [MHz]	Parameters	Region A		Region B
1.4	RB _{start}	0		1-2
	L _{CRB} [RBs]	≤3	≥4	≥4
	A-MPR [dB]	≤3	≤6	≤3
3	RB _{start}	0-3		4-5
	L _{CRB} [RBs]	1-15		≥9
	A-MPR [dB]	≤4		≤3
5	RB _{start}	0-6		0-9
	L _{CRB} [RBs]	≤8		≥9
	A-MPR [dB]	≤5		≤3
10	RB _{start}	0-15		0-22
	L _{CRB} [RBs]	≤18		≥20
	A-MPR [dB]	≤4		≤2
15	RB _{start}	0-30		0-30
	L _{CRB} [RBs]	≤30		≥32
	A-MPR [dB]	≤4		≤3

Table 6.2.4-7: A-MPR for "NS_13"

Channel bandwidth [MHz]	Parameters	Region A	
5	RB _{start}	0-2	
	LCRB [RBs]	≤5	≥18
	A-MPR [dB]	≤3	≤2

Table 6.2.4-8: A-MPR for "NS_14"

Channel bandwidth [MHz]	Parameters	Region A	
10	RB _{start}	0	
	LCRB [RBs]	≤5	≥50
	A-MPR [dB]	≤3	≤1
15	RB _{start}	≤8	
	LCRB [RBs]	≤16	≥50
	A-MPR [dB]	≤3	≤1

Table 6.2.4-9: A-MPR for "NS_15" for E-UTRA highest channel edge > 845 MHz and ≤ 849 MHz

Channel bandwidth [MHz]	Parameters	Region A	Region B	Region C
1.4	RB _{end} [RB]			4-5
	A-MPR [dB]			≤3
3	RB _{end} [RB]	0-1	8-12	13-14
	LCRB [RB]	≤2	≥8	>0
	A-MPR [dB]	≤4	≤4	≤9
5	RB _{end} [RB]	0-4	12-19	20-24
	LCRB [RB]	≤2	≥8	>0
	A-MPR [dB]	≤4	≤5	≤9
10	RB _{end} [RB]	0-12	23-36	37-49
	LCRB [RB]	≤2	≥15	>0
	A-MPR [dB]	≤4	≤6	≤9
15	RB _{end} [RB]	0-20	26-53	54-74
	LCRB [RB]	≤2	≥20	>0
	A-MPR [dB]	≤4	≤5	≤9

Table 6.2.4-10: A-MPR for "NS_15" for E-UTRA highest channel edge ≤ 845 MHz

Channel bandwidth [MHz]	Parameters	Region A	Region B	Region C
5	RB _{end} [RB]			19-24
	LCRB [RB]			≥18
	A-MPR [dB]			≤2
10	RB _{end} [RB]	0-4	29-44	45-49
	LCRB [RB]	≤2	≥24	>0
	A-MPR [dB]	≤4	≤4	≤9
15	RB _{end} [RB]	0-12	44-61	62-74
	LCRB [RB]	≤2	≥20	>0
	A-MPR [dB]	≤4	≤5	≤9

Table 6.2.4-11: A-MPR for "NS_16" with channel lower edge at ≥ 807 MHz and < 808.5 MHz

Channel bandwidth [MHz]	Parameter	Region A	Region B	Region C	Region D	Region E
3 MHz	RB _{start}	0	1-2			
	LCRB [RBs]	≥ 12	12			
	A-MPR [dB]	≤ 2	≤ 1			
5 MHz	RB _{start}	0-1	2	2-9	2-5	
	LCRB [RBs]	1 - 25	12	15-18	20	
	A-MPR [dB]	≤ 5	≤ 1	≤ 2	≤ 3	
10 MHz	RB _{start}	0 - 8	0-14		15-20	15-24
	LCRB [RBs]	1 - 12	15-20	≥ 24	≥ 30	24-27
	A-MPR [dB]	≤ 5	≤ 3	≤ 7	≤ 3	≤ 1

Table 6.2.4-12: A-MPR for "NS_16" with channel lower edge at ≥ 808.5 MHz and < 812 MHz

Channel bandwidth [MHz]	Parameter	Region A	Region B	Region C	Region D	Region E
5 MHz	RB _{start}	0	0-1	1-5		
	LCRB [RBs]	16-20	≥ 24	16-20		
	A-MPR [dB]	≤ 2	≤ 3	≤ 1		
10 MHz	RB _{start}	0-6		0-10	0-14	11-20
	LCRB [RBs]	1-12	15-20	24-32	≥ 36	24-32
	A-MPR [dB]	≤ 5	≤ 2	≤ 4	≤ 5	≤ 1

Table 6.2.4-13: A-MPR for "NS_16" with channel lower edge at ≥ 812 MHz

Channel bandwidth [MHz]	Parameter	Region A	Region B	Region C	Region D
10 MHz	RB _{start}	0 - 9	0	1-14	0-5
	LCRB [RBs]	27-32	36-40	36-40	≥ 45
	A-MPR [dB]	≤ 1	≤ 2	≤ 1	≤ 3

Table 6.2.4-14: A-MPR for "NS_19"

Channel bandwidth [MHz]	Parameters	Region A		Region B
10	RB _{start}			0-6
	LCRB [RBs]			≥ 40
	A-MPR [dB]			≤ 1
15	RB _{start}	0-6		7-20
	LCRB [RBs]	≤ 18	≥ 36	≥ 42
	A-MPR [dB]	≤ 2	≤ 3	≤ 2
20	RB _{start}	0-14		15-30
	LCRB [RBs]	≤ 40	≥ 45	≥ 50
	A-MPR [dB]	≤ 2	≤ 3	≤ 2

Table 6.2.4-15: A-MPR for "NS_20"

Channel Bandwidth [MHz]	Parameters							
5	Fc [MHz]	< 2007.5		2007.5 ≤ Fc < 2012.5		2012.5 ≤ Fc ≤ 2017.5		
	RB _{start}	≤24		0-3	4-6	≤24		
	LCRB [RBs]	>0		15-19	≥20	≥18	1-25	
	A-MPR [dB]	≤17		≤1	≤4	≤2	≤0	
10	Fc [MHz]	2005						
	RB _{start}	0-25		26-34		35-49		
	LCRB [RBs]	>0		8-15	>15	>0		
	A-MPR [dB]	≤16		≤2	≤5	≤6		
	Fc [MHz]	2015						
	RB _{start}	0-5			6-10			
	LCRB [RBs]	≥32			≥40			
A-MPR [dB]	≤4			≤2				
15	Fc [MHz]	2012.5						
	RB _{start}	0-14		15-24		25-39	61-74	
	LCRB [RBs]	1-9 & 40-75	10-39	24-29	≥30	≥36	≤6	
	A-MPR [dB]	≤11	≤6	≤1	≤7	≤5	≤6	
20	Fc [MHz]	2010						
	RB _{start}	0-21	22-31		32-38	39-49	50-68	69-99
	LCRB [RBs]	>0	1-9 & 31-75	10-30	≥15	≥24	≥25	>0
	A-MPR [dB]	≤17	≤12	≤6	≤9	≤7	≤5	≤16
NOTE 1: When NS_20 is signaled the minimum requirements for the 10 MHz bandwidth are specified for E-UTRA UL carrier center frequencies of 2005 MHz or 2015 MHz.								
NOTE 2: When NS_20 is signaled the minimum requirements for the 15 MHz channel bandwidth are specified for E-UTRA UL carrier center frequency of 2012.5 MHz.								

Table 6.2.4-16: A-MPR for "NS_21"

Channel Bandwidth [MHz]	Parameters	Region A		Region B	
10	RB _{start}	0 – 6	0 – 6	N/A	N/A
	RB _{end}	N/A	N/A	43 – 49	43 – 49
	LCRB [RBs]	1 – 2	3 – 12, 32 - 50	1 – 2	3 – 12, 32 - 50
	A-MPR [dB]	≤ 4	≤ 3	≤ 4	≤ 3

Table 6.2.4-17: A-MPR for "NS_22"

Channel bandwidth [MHz]	Parameters	Region A	Region B	Region C	Region D
5	No A-MPR is needed for 5 MHz channel bandwidth				
10	RB _{start}	0-13	0-17	≤ 6	≥ 12
	LCRB [RBs]	> 36	33-36	≤ 32	≤ 32
	RB _{start} + LCRB [RBs]	N/A	N/A	N/A	≥ 44
	A-MPR [dB]	≤ 4	≤ 3	≤ 3	≤ 3
15	RB _{start}	0-24	0-38	≤ 14	≥ 23
	LCRB [RBs]	> 50	37-50	≤ 36	≤ 36
	RB _{start} + LCRB [RBs]	N/A	N/A	N/A	≥ 59
	A-MPR [dB]	≤ 5	≤ 4	≤ 3	≤ 3
20	RB _{start}	0-35	0-51	≤ 21	≥ 31
	LCRB [RBs]	> 64	49-64	≤ 48	≤ 48
	RB _{start} + LCRB [RBs]	N/A	N/A	N/A	≥ 79
	A-MPR [dB]	≤ 5	≤ 4	≤ 3	≤ 3
NOTE 1; RB _{start} indicates the lowest RB index of transmitted resource blocks					
NOTE 2; LCRB is the length of a contiguous resource block allocation					
NOTE 3; For intra-subframe frequency hopping between two regions, notes 1 and 2 apply on a per slot basis.					
NOTE 4; For intra-subframe frequency hopping between two regions, the larger A-MPR value of the two regions may be applied for both slots in the subframe.					

Table 6.2.4-18: A-MPR for "NS_05"

Channel Bandwidth [MHz]	Parameters							
15	F _c [MHz]	1932.5						
	RB _{start}	0-7	8 – 66				67-74	
	LCRB [RBs]	≥ 1	≤ 30	31 – 54	> 54	≤ 6	> 6	
	A-MPR [dB]	≤ 11	0	≤ 3	≤ 5	≤ 5	≤ 1	
20	F _c [MHz]	1930						
	RB _{start}	0-23	24-75				76-99	
	LCRB [RBs]	≥ 1	≤ 24	25 – 40	41 – 50	> 50	≤ 6	> 6
	A-MPR [dB]	≤ 11	0	≤ 3	≤ 5	≤ 10	≤ 5	≤ 1

Table 6.2.4-19: Void

Table 6.2.4-20: Void

Table 6.2.4-21: Void

Table 6.2.4-22: Void

Table 6.2.4-23: Void

Table 6.2.4-24: Void

Table 6.2.4-25: Void

Table 6.2.4-26: Void

Table 6.2.4-27: Void

Table 6.2.4-28: Void

Table 6.2.4-29: Void

Table 6.2.4-30a: Void

Table 6.2.4-30b: Void

Table 6.2.4-31: Void

Table 6.2.4-32: Void

Table 6.2.4-32a: Void

Table 6.2.4-32b: Void

Table 6.2.4-33: Void

Table 6.2.4-34: Void

Table 6.2.4-34a: A-MPR for "NS_56"

Channel bandwidth confined to 1627.5- 1637.5MHz									
Channel bandwidth	Carrier centre frequency (Fc) (MHz)	Parameters	Region A	Region B	Region C	Region D	Region E	Region F	Region G
5 MHz	1630.0, 1630.3	RB _{start}	≤ 8	≤ 8	N/A	N/A	N/A	N/A	N/A
		LCRB [RBs]	≤ 8	> 8	N/A	N/A	N/A	N/A	N/A
		A-MPR [dB]	8	2	N/A	N/A	N/A	N/A	N/A
	1635.0	No A-MPR needed							
	1649.0								
1654.0									
10 MHz	1632.5	RB _{start}	≤ 5	≤ 18	≤ 18	≥ 35	≥ 35	≥ 40	≥ 40
		LCRB [RBs]	≤ 5	≤ 12	> 12	≤ 7	> 7	≤ 7	> 7
		A-MPR [dB]	7	5	7	4	2	5	3
	1651.5	No A-MPR needed							



For PRACH, PUCCH and SRS transmissions, the allowed A-MPR is according to that specified for PUSCH QPSK modulation for the corresponding transmission bandwidth.

For each subframe, the A-MPR is evaluated per slot and given by the maximum value taken over the transmission(s) within the slot; the maximum A-MPR over the two slots is then applied for the entire subframe.

For the UE maximum output power modified by A-MPR, the power limits specified in subclause 6.2.5 apply.

6.2.4A UE maximum output power with additional requirements for CA

Additional ACLR, spectrum emission and spurious emission requirements for carrier aggregation can be signalled by the network to indicate that the UE shall also meet additional requirements in a specific deployment scenario. To meet these additional requirements, Additional Maximum Power Reduction (A-MPR) is allowed for the CA Power Class as specified in Table 6.2.2A-1.

If for intra-band carrier aggregation the UE is configured for transmissions on a single serving cell, then subclauses 6.2.3 and 6.2.4 apply with the Network Signaling value indicated by the field *additionalSpectrumEmission*.

For intra-band contiguous aggregation with the UE configured for transmissions on two serving cells, the maximum output power reduction specified in Table 6.2.4A-1 is allowed for all serving cells of the applicable uplink CA configurations according to the CA network signalling value indicated by the field *additionalSpectrumEmissionSCell-r10*. Then clause 6.2.3A does not apply, i.e. the carrier aggregation MPR = 0dB, unless the value indicated is CA_NS_31.

Table 6.2.4A-1: Additional Maximum Power Reduction (A-MPR) for intra-band contiguous CA

CA Network Signalling value	Requirements (subclause)	Uplink CA Configuration	A-MPR [dB] (subclause)
CA_NS_01	6.6.3.3A.1	CA_1C	6.2.4A.1
CA_NS_02	6.6.3.3A.2	CA_1C	6.2.4A.2
CA_NS_03	6.6.3.3A.3	CA_1C	6.2.4A.3
CA_NS_04	6.6.2.2A.1, 6.6.3.3A.8	CA_41C	6.2.4A.4
CA_NS_05	6.6.3.3A.4	CA_38C	6.2.4A.5
CA_NS_06	6.6.3.3A.5	CA_7C	6.2.4A.6
CA_NS_07	6.6.3.3A.6	CA_39C	6.2.4A.7
CA_NS_08	6.6.3.3A.7	CA_42C	6.2.4A.8
...			
CA_NS_31	NOTE 1	Table 5.6A.1-1 (NOTE 1)	N/A
CA_NS_32		Reserved	
NOTE 1: Applicable for uplink CA configurations listed in Table 5.6A.1-1 for which none of the additional requirements in subclauses 6.6.2.2A or 6.6.3.3A apply.			
NOTE 2: The index of the sequence CA_NS corresponds to the value of <i>additionalSpectrumEmissionSCell-r10</i> .			

If for intra-band non-contiguous carrier aggregation the UE is configured for transmissions on a single serving cell, then subclauses 6.2.3 and 6.2.4 apply with the Network Signaling value indicated by the field *additionalSpectrumEmission*.

For intra-band non-contiguous carrier aggregation with the UE configured for transmissions on two serving cells, the maximum output power reduction specified in Table 6.2.4A-2 is allowed for all serving cells of the applicable uplink CA configurations according to the CA network signalling value indicated by the field *additionalSpectrumEmissionSCell-r10*. MPR as specified in subclause 6.2.3A is not allowed in addition, unless A-MPR is N/A.

Table 6.2.4A-2: Additional Maximum Power Reduction (A-MPR) for intra-band non-contiguous CA

CA Network Signalling value	Additional requirements for sub-blocks in order of increasing uplink carrier frequency		Uplink CA Configuration	A-MPR for sub-blocks in order of increasing uplink carrier frequency
	Requirements (subclause)	Requirements (subclause)		A-MPR [dB] (subclause)
CA_NC_NS_01	6.6.2.2.1 (NS_03)	6.6.2.2.1 (NS_03)	CA_4A-4A	N/A
...				
CA_NC_NS_31	NOTE 1	NOTE 1	Table 5.6A.1-3 (NOTE 1)	N/A
CA_NC_NS_32	Reserved			
NOTE 1: Applicable for uplink CA configurations listed in Table 5.6A.1-3 for which the additional requirements in subclause 6.6.2.1.1 (indicated by NS_01) applies in each sub-block.				
NOTE 2: The index of the sequence CA_NC_NS corresponds to the value of <i>additionalSpectrumEmissionSCell-r10</i> .				

If for inter-band carrier aggregation the UE is configured for transmissions on a single serving cell, then subclauses 6.2.3 and 6.2.4 apply with the Network Signaling value indicated by the field *additionalSpectrumEmission*.

For inter-band carrier aggregation with the UE configured for transmissions on two serving cells the maximum output power reduction specified in Table 6.2.4-1 is allowed for each serving cell of the applicable uplink CA configuration according to the Network Signaling value indicated by the field *additionalSpectrumEmission* for the PCC and the CA network signalling value indicated by the field *additionalSpectrumEmissionSCell-r10* for the SCC. The value of *additionalSpectrumEmissionSCell-r10* is equal to that of *additionalSpectrumEmission* configured on the SCC. MPR as specified in subclause 6.2.3A is allowed in addition.

For PUCCH and SRS transmissions, the allowed A-MPR is according to that specified for PUSCH QPSK modulation for the corresponding transmission bandwidth.

For intra-band carrier aggregation, the A-MPR is evaluated per slot and given by the maximum value taken over the transmission(s) on all component carriers within the slot; the maximum A-MPR over the two slots is then applied for the entire subframe.

For the UE maximum output power modified by A-MPR specified in table 6.2.4A-1, the power limits specified in subclause 6.2.5A apply.

6.2.4A.1 A-MPR for CA_NS_01 for CA_1C

If the UE is configured to CA_1C and it receives IE CA_NS_01 the allowed maximum output power reduction applied to transmissions on the PCC and the SCC for contiguously aggregated signals is specified in table 6.2.4A.1-1.

Table 6.2.4A.1-1: Contiguous allocation A-MPR for CA_NS_01

CA_1C: CA_NS_01	RB _{start}	L _{CRB} [RBs]	RB _{start} + L _{CRB} [RBs]	A-MPR for QPSK and 16-QAM [dB]
100 RB / 100 RB	0 – 23 and 176 – 199	> 0	N/A	≤ 12.0
	24 – 105	> 64	N/A	≤ 6.0
	106 – 175	N/A	> 175	≤ 5.0
75 RB / 75 RB	0 – 6 and 143 – 149	0 < L _{CRB} ≤ 10	N/A	≤ 11.0
		> 10	N/A	≤ 6.0
	7 – 90	> 44	N/A	≤ 5.0
	91 – 142	N/A	> 142	≤ 2.0
NOTE 1: RB _{start} indicates the lowest RB index of transmitted resource blocks NOTE 2: L _{CRB} is the length of a contiguous resource block allocation NOTE 3: For intra-subframe frequency hopping which intersects regions, notes 1 and 2 apply on a per slot basis NOTE 4: For intra-subframe frequency hopping which intersects regions, the larger A-MPR value may be applied for both slots in the subframe				

If the UE is configured to CA_1C and it receives IE CA_NS_01 the allowed maximum output power reduction applied to transmissions on the PCell and the SCell with non-contiguous resource allocation is defined as follows

$$\text{A-MPR} = \text{CEIL} \{M_A, 0.5\}$$

Where M_A is defined as follows

$$M_A = \begin{cases} -22.5 A + 17 & ; 0 \leq A < 0.20 \\ -11.0 A + 14.7 & ; 0.20 \leq A < 0.70 \\ -1.7 A + 8.2 & ; 0.70 \leq A \leq 1 \end{cases}$$

Where $A = N_{\text{RB_alloc}} / N_{\text{RB_agg}}$.

6.2.4A.2 A-MPR for CA_NS_02 for CA_1C

If the UE is configured to CA_1C and it receives IE CA_NS_02 the allowed maximum output power reduction applied to transmission on the PCC and the SCC for contiguously aggregated signals is specified in Table 6.2.4A.2-1.

Table 6.2.4A.2-1: Contiguous allocation A-MPR for CA_NS_02

CA_1C: CA_NS_02	RB _{end}	L _{CRB} [RBs]	A-MPR for QPSK and 16-QAM [dB]
100 RB / 100 RB	0 – 20	> 0	≤ 4 dB
	21 – 46	> 0	≤ 3 dB
	47 – 99	> RB _{end} - 20	≤ 3 dB
	100 – 184	> 75	≤ 6 dB
	185 – 199	> 0	≤ 10 dB
75 RB / 75 RB	0 – 48	> 0	≤ 2 dB
	49 – 80	> RB _{end} - 20	≤ 3 dB
	81 – 129	> 60	≤ 5 dB
	130 – 149	> 84	≤ 6 dB
	130 – 149	1 – 84	≤ 2 dB

If the UE is configured to CA_1C and it receives IE CA_NS_02 the allowed maximum output power reduction applied to transmissions on the PCell and the SCell with non-contiguous resource allocation is defined as follows:

$$A\text{-MPR} = \text{CEIL} \{M_A, 0.5\}$$

Where M_A is defined as follows

$$M_A = \begin{aligned} & -22.5 A + 17 && ; 0 \leq A < 0.20 \\ & -11.0 A + 14.7 && ; 0.20 \leq A < 0.70 \\ & -1.7 A + 8.2 && ; 0.70 \leq A \leq 1 \end{aligned}$$

Where $A = N_{\text{RB_alloc}} / N_{\text{RB_agg}}$.

6.2.4A.3 A-MPR for CA_NS_03 for CA_1C

If the UE is configured to CA_1C and it receives IE CA_NS_03 the allowed maximum output power reduction applied to transmission on the PCC and the SCC for contiguously aggregated signals is specified in Table 6.2.4A.3-1.

Table 6.2.4A.3-1: Contiguous allocation A-MPR for CA_NS_03

CA_1C: CA_NS_03	RB _{end}	L _{CRB} [RBs]	A-MPR for QPSK and 16-QAM [dB]
100 RB / 100 RB	0 – 26	> 0	≤ 10 dB
	27 – 63	≥ RB _{end} - 27	≤ 6 dB
	27 – 63	< RB _{end} - 27	≤ 1 dB
	64 – 100	> RB _{end} - 20	≤ 4 dB
	101 – 171	> 68	≤ 7 dB
	172 – 199	> 0	≤ 10 dB
75 RB / 75 RB	0 – 20	> 0	≤ 10 dB
	21 – 45	> 0	≤ 4 dB
	46 – 75	> RB _{end} - 13	≤ 2 dB
	76 – 95	> 45	≤ 5 dB
	96 – 149	> 43	≤ 8 dB
	120 – 149	1 - 43	≤ 6 dB

If the UE is configured to CA_1C and it receives IE CA_NS_03 the allowed maximum output power reduction applied to transmissions on the PCell and the SCell with non-contiguous resource allocation is defined as follows:

$$A\text{-MPR} = \text{CEIL} \{M_A, 0.5\}$$

Where M_A is defined as follows

$$M_A = \begin{aligned} & -23.33A + 17.5 && ; 0 \leq A < 0.15 \\ & -7.65A + 15.15 && ; 0.15 \leq A \leq 1 \end{aligned}$$

Where $A = N_{\text{RB_alloc}} / N_{\text{RB_agg}}$.

6.2.4A.4 A-MPR for CA_NS_04

If the UE is configured to CA_41C and it receives IE CA_NS_04 the allowed maximum output power reduction applied to transmission on the PCC and the SCC for contiguously aggregated signals is specified in Table 6.2.4A.4-1.

Table 6.2.4A.4-1: Contiguous Allocation A-MPR for CA_NS_04

CA Bandwidth Class C	RB _{Start}	LCRB [RBs]	RB _{Start} + LCRB [RBs]	A-MPR for QPSK [dB]	A-MPR for 16QAM [dB]
25 RB / 100 RB	0 – 34 and 90 – 124	>0	N/A	≤3dB	≤3.5dB
	35 – 89	N/A	>90	≤1dB	≤2.5dB
50RB / 100 RB	0 – 44 and 105 – 149	>0	N/A	≤4dB	≤4dB
	45 – 104	N/A	>105	≤3dB	≤4dB
75 RB / 75 RB	0 – 44 and 105 – 149	>0	N/A	≤4dB	≤4dB
	45 – 104	N/A	>105	≤4dB	≤4dB
100 RB / 75 RB	0 – 49 and 125 – 174	>0	N/A	≤4dB	≤4dB
	50 - 124	N/A	>125	≤3dB	≤4dB
100 RB / 100 RB	0 – 59 and 140 – 199	>0	N/A	≤3dB	≤4dB
	60– 139	N/A	>140	≤3dB	≤4dB

NOTE 1: RB_{start} indicates the lowest RB index of transmitted resource blocks
NOTE 2: L_{CRB} is the length of a contiguous resource block allocation
NOTE 3: For intra-subframe frequency hopping which intersects regions, notes 1 and 2 apply on a per slot basis
NOTE 4: For intra-subframe frequency hopping which intersects regions, the larger A-MPR value may be applied for both slots in the subframe

If the UE is configured to CA_41C and it receives IE CA_NS_04 the allowed maximum output power reduction applied to transmissions on the PCell and the SCell with non-contiguous resource allocation is defined as follows

$$A\text{-MPR} = \text{CEIL} \{M_A, 0.5\}$$

Where M_A is defined as follows

$$\begin{aligned}
M_A &= 11, & 0 \leq A < 0.05 \\
&= -55.0A + 13.75, & 0.05 \leq A < 0.15 \\
&= -4.0A + 6.10, & 0.15 \leq A < 0.40 \\
&= -0.83A + 4.83, & 0.40 \leq A \leq 1
\end{aligned}$$

Where $A = N_{\text{RB_alloc}} / N_{\text{RB_agg}}$.

6.2.4A.5 A-MPR for CA_NS_05 for CA_38C

If the UE is configured to CA_38C and it receives IE CA_NS_05 the allowed maximum output power reduction applied to transmission on the PCC and the SCC for contiguously aggregated signals is specified in Table 6.2.4A.5-1.

Table 6.2.4A.5-1: Contiguous Allocation A-MPR for CA_NS_05

CA_38C	RB _{end}	L _{CRB} [RBs]	A-MPR for QPSK and 16-QAM [dB]
100RB/100RB	0 – 12	>0	≤ 5 dB
	13 – 79	> RB _{end} – 13	≤ 2 dB
	80 – 180	>60	≤ 6 dB
	181 – 199	> 0	≤ 11 dB
75RB/75RB	0 – 70	> max (0, RB _{end} -10)	≤ 2 dB
	71- 108	> 60	≤ 5 dB
	109 – 139	>0	≤ 5 dB
	140 – 149	≤ 70	≤ 2 dB
	140 – 149	>70	≤ 6 dB
NOTE 1: RB _{end} indicates the highest RB index of transmitted resource blocks NOTE 2: L _{CRB} is the length of a contiguous resource block allocation NOTE 3: For intra-subframe frequency hopping which intersects regions, notes 1 and 2 apply on a per slot basis NOTE 4: For intra-subframe frequency hopping which intersects regions, the larger A-MPR value may be applied for both slots in the subframe			

If the UE is configured to CA_38C and it receives IE CA_NS_05 the allowed maximum output power reduction applied to transmissions on the PCell and the SCell with non-contiguous resource allocation is defined as follows

$$A\text{-MPR} = \text{CEIL} \{M_A, 0.5\}$$

Where MA is defined as follows

$$M_A = -14.17 A + 16.50 \quad ; 0 \leq A < 0.60$$

$$-2.50 A + 9.50 \quad ; 0.60 \leq A \leq 1$$

Where $A = N_{\text{RB_alloc}} / N_{\text{RB_agg}}$.

6.2.4A.6 A-MPR for CA_NS_06

If the UE is configured to CA_7C and it receives IE CA_NS_06 the allowed maximum output power reduction applied to transmission on the PCC and the SCC for contiguously aggregated signals is specified in Table 6.2.4A.6-1.

Table 6.2.4A.6-1: Contiguous Allocation A-MPR for CA_NS_06

CA Bandwidth Class C	RB _{end}	L _{CRB} [RBs]	A-MPR for QPSK and 16-QAM [dB]
100RB/100RB	0 – 22	>0	≤ 4 dB
	23 – 99	> max(0, RB _{end} – 25)	≤ 2 dB
	100 – 142	> 75	≤ 3 dB
	143 – 177	>70	≤ 5 dB
	178 – 199	> 0	≤ 10 dB
75RB/75RB	0 – 7	>0	≤ 5 dB
	8- 74	> max(0, RB _{end} – 10)	≤ 2 dB
	75 – 109	>64	≤ 2 dB
	110 – 144	>35	≤ 6 dB
	145 – 149	>0	≤ 10 dB
50RB/100RB and 100RB/50RB	0 – 10	> 0	≤ 5 dB
	11 – 75	> max(0, RB _{End} – 25)	≤ 2 dB
	76 – 103	> 50	≤ 3 dB
	104 – 144	> 25	≤ 6 dB
	145 – 149	> 0	≤ 10 dB
75RB/100RB and 100RB/75RB	0 – 15	> 0	≤ 5 dB
	16 – 75	> max(0, RB _{End} – 15)	≤ 2 dB
	76 – 120	> 50	≤ 3 dB
	121 – 160	> 50	≤ 6 dB
	161 – 174	> 0	≤ 10 dB

If the UE is configured to CA_7C and it receives IE CA_NS_06 the allowed maximum output power reduction applied to transmissions on the PCell and the SCell with non-contiguous resource allocation is defined as follows:

$$A\text{-MPR} = \text{CEIL} \{M_A, 0.5\}$$

Where M_A is defined as follows

$$M_A = -13.33A + 17.5 \quad ; 0 \leq A < 0.15$$

$$-6.47A + 16.47 \quad ; 0.15 \leq A \leq 1$$

Where $A = N_{RB_alloc} / N_{RB_agg}$.

6.2.4A.7 A-MPR for CA_NS_07

If the UE is configured to CA_39C and it receives IE CA_NS_07 the allowed maximum output power reduction applied to transmission on the PCC and the SCC for contiguously aggregated signals is specified in Table 6.2.4A.7-1.

Table 6.2.4A.7-1: Contiguous Allocation A-MPR for CA_NS_07

CA_39C: CA_NS_07	RB _{start}	L _{CRB} [RBs]	A-MPR for QPSK and 16-QAM[dB]
75 RB / 100 RB and 100 RB / 75 RB	0 – 13	> 0	≤ 11
	14 – 50	≤ 60	≤ 3
	14 – 100	> 60	≤ 7
	101 – 155	> max(155 - RB _{start} , 0)	≤ 2
	156 – 174	> 0	≤ 5
50 RB / 100 RB and 100 RB / 50 RB	0 – 5	> 0	≤ 11
	6 – 42	≤ 25	≤ 3
		> 25	≤ 6
	43 – 80	> 50	≤ 5
	81 – 138	> 20	≤ 2
139 – 149	> 0	≤ 5	
25 RB / 100 RB and 100 RB / 25 RB	0 – 32	≥ 84	≤ 6
		< 84	≤ 4
	33 – 60	> 50	≤ 3
	61 – 124	> 20	≤ 3

If the UE is configured to CA_39C and it receives IE CA_NS_07 the allowed maximum output power reduction applied to transmissions on the PCell and the SCell with non-contiguous resource allocation is defined as follows

$$A\text{-MPR} = \text{CEIL} \{M_A, 0.5\}$$

Where M_A is defined as follows

$$M_A = -16.25A + 21 \quad ; 0 \leq A < 0.80$$

$$-2.50A + 10.00 \quad ; 0.80 \leq A \leq 1$$

Where $A = N_{\text{RB_alloc}} / N_{\text{RB_agg}}$

6.2.4A.8 A-MPR for CA_NS_08

If the UE is configured to CA_42C and it receives IE CA_NS_08 the allowed maximum output power reduction applied to transmission on the PCC and the SCC for contiguously aggregated signals is specified in Table 6.2.4A.8-1.

Table 6.2.4A.8-1: Contiguous Allocation A-MPR for CA_NS_08

CA_42C: CA_NS_08	RBstart	Condition	RBend	L _{CRB} [RBs]	A-MPR for QPSK and 16- QAM[dB]
100RB / 100RB	≤ 21	Or	≥ 178	≤ 25	≤ 12
				> 25 and ≤ 80	≤ 6
	≥ 0	N/A	N/A	> 80 and ≤ 172	≤ 8
				> 172	≤ 9
	> 21 and ≤ 58	Or	≥ 141 and < 178	< 48	≤ 3
> 21	And	< 178	≥ 48 and ≤ 80	≤ 4	
100RB / 75RB And 75RB / 100RB	≤ 12	Or	≥ 162	≤ 25	≤ 12
				> 25 and ≤ 75	≤ 6
	≥ 0	N/A	N/A	> 75 and < 172	≤ 8
				≥ 172	9
	> 12 and ≤ 49	Or	≥ 125 and < 162	< 54	≤ 3
> 12	And	< 162	≥ 54 and ≤ 75	≤ 5	
> 49	And	< 125	≥ 36 and < 54	≤ 2	
75RB / 75RB and 100RB / 50RB And 50RB / 100RB	≤ 5	Or	≥ 144	≤ 16	≤ 12
				> 16 and ≤ 61	≤ 6
	≥ 0	N/A	N/A	> 61	≤ 8
				> 5	And
> 5 and ≤ 41	Or	≥ 108 and < 144	< 36	≤ 3	
100RB / 25RB And 25RB / 100RB	≤ 31	Or	≥ 92	≤ 34	≤ 4
				> 34 and ≤ 44	≤ 5
	≥ 0	N/A	N/A	> 44	≤ 8
NOTE 1: RB _{start} indicates the lowest RB index of transmitted resource blocks					
NOTE 2: L _{CRB} is the length of a contiguous resource block allocation					
NOTE 3: RB _{end} indicates the highest RB index of transmitted resource blocks					
NOTE 4: If condition is "and" both RB _{start} and RB _{end} constraints need to be met. If condition is "or" either RB _{start} or RB _{end} constraints need to be met					
NOTE 5: For intra-subframe frequency hopping which intersects regions, notes 1, 2, 3 and 4 apply on a per slot basis					
NOTE 6: For intra-subframe frequency hopping which intersects regions, the larger A-MPR value may be applied for both slots in the subframe					

If the UE is configured to CA_42C and it receives IE CA_NS_08 the allowed maximum output power reduction applied to transmissions on the PCell and the SCell with non-contiguous resource allocation is defined as follows

$$A\text{-MPR} = \text{CEIL} \{M_A, 0.5\}$$

Where MA is defined as follows

$$M_A = \begin{cases} 20 & 0 \leq A < 0.025 \\ 23 - 120A & 0.025 \leq A < 0.05 \\ 17.53 - 10.59A & 0.05 \leq A \leq 0.9 \\ 8 & 0.9 \leq A \leq 1 \end{cases}$$

Where $A = N_{\text{RB_alloc}} / N_{\text{RB_agg}}$.

6.2.4B UE maximum output power with additional requirements for UL-MIMO

For UE with two transmit antenna connectors in closed-loop spatial multiplexing scheme, the A-MPR values specified in subclause 6.2.4 shall apply to the maximum output power specified in Table 6.2.2B-1. The requirements shall be met with the UL-MIMO configurations specified in Table 6.2.2B-2. For UE supporting UL-MIMO, the maximum output power is measured as the sum of the maximum output power at each UE antenna connector. Unless stated otherwise, an A-MPR of 0 dB shall be used.

For the UE maximum output power modified by A-MPR, the power limits specified in subclause 6.2.5B apply.

If UE is configured for transmission on single-antenna port, the requirements in subclause 6.2.4 apply.

6.2.4D UE maximum output power with additional requirements for ProSe

The allowed A-MPR for the maximum output power for ProSe physical channels PSDCH, PSCCH, PSSCH, and PSBCH shall be as specified in subclause 6.2.4 for PUSCH for the corresponding modulation and transmission bandwidth.

The allowed A-MPR for the maximum output power for ProSe physical signal PSSS and SSSS shall be as specified in subclause 6.2.4 for PUSCH QPSK modulation for the corresponding transmission bandwidth.

6.2.5 Configured transmitted power

The UE is allowed to set its configured maximum output power $P_{\text{CMAX},c}$ for serving cell c . The configured maximum output power $P_{\text{CMAX},c}$ is set within the following bounds:

$P_{\text{CMAX}_L,c} \leq P_{\text{CMAX},c} \leq P_{\text{CMAX}_H,c}$ with

$$P_{\text{CMAX}_L,c} = \text{MIN} \{ P_{\text{EMAX},c} - \Delta T_{C,c}, P_{\text{PowerClass}} - \text{MAX}(MPR_c + A\text{-MPR}_c + \Delta T_{\text{IB},c} + \Delta T_{C,c} + \Delta T_{\text{ProSe}}, P\text{-MPR}_c) \}$$

$$P_{\text{CMAX}_H,c} = \text{MIN} \{ P_{\text{EMAX},c}, P_{\text{PowerClass}} \}$$

where

- $P_{\text{EMAX},c}$ is the value given by IE *P-Max* for serving cell c , defined in [7];
- $P_{\text{PowerClass}}$ is the maximum UE power specified in Table 6.2.2-1 without taking into account the tolerance specified in the Table 6.2.2-1;
- MPR_c and $A\text{-MPR}_c$ for serving cell c are specified in subclause 6.2.3 and subclause 6.2.4, respectively;
- $\Delta T_{\text{IB},c}$ is the additional tolerance for serving cell c as specified in Table 6.2.5-2; $\Delta T_{\text{IB},c} = 0$ dB otherwise;
- $\Delta T_{C,c} = 1.5$ dB when Note 2 in Table 6.2.2-1 applies;
- $\Delta T_{C,c} = 0$ dB when Note 2 in Table 6.2.2-1 does not apply;
- $\Delta T_{\text{ProSe}} = 0.1$ dB when the UE supports ProSe Direct Discovery and/or ProSe Direct Communication on the corresponding E-UTRA ProSe band; $\Delta T_{\text{ProSe}} = 0$ dB otherwise.

$P\text{-MPR}_c$ is the allowed maximum output power reduction for

- a) ensuring compliance with applicable electromagnetic energy absorption requirements and addressing unwanted emissions / self desense requirements in case of simultaneous transmissions on multiple RAT(s) for scenarios not in scope of 3GPP RAN specifications;
- b) ensuring compliance with applicable electromagnetic energy absorption requirements in case of proximity detection is used to address such requirements that require a lower maximum output power.

The UE shall apply $P\text{-MPR}_c$ for serving cell c only for the above cases. For UE conducted conformance testing $P\text{-MPR}$ shall be 0 dB

NOTE 1: $P\text{-MPR}_c$ was introduced in the $P_{\text{CMAX},c}$ equation such that the UE can report to the eNB the available maximum output transmit power. This information can be used by the eNB for scheduling decisions.

NOTE 2: $P\text{-MPR}_c$ may impact the maximum uplink performance for the selected UL transmission path.

For each subframe, the $P_{\text{CMAX}_L,c}$ for serving cell c is evaluated per slot and given by the minimum value taken over the transmission(s) within the slot; the minimum $P_{\text{CMAX}_L,c}$ over the two slots is then applied for the entire subframe. $P_{\text{PowerClass}}$ shall not be exceeded by the UE during any period of time.

The measured configured maximum output power $P_{\text{UMAX},c}$ shall be within the following bounds:

$$P_{\text{CMAX}_L,c} - \text{MAX}\{T_{L,c}, T(P_{\text{CMAX}_L,c})\} \leq P_{\text{UMAX},c} \leq P_{\text{CMAX}_H,c} + T(P_{\text{CMAX}_H,c}).$$

where the tolerance $T(P_{\text{CMAX},c})$ for applicable values of $P_{\text{CMAX},c}$ is specified in Table 6.2.5-1. The tolerance $T_{L,c}$ is the absolute value of the lower tolerance for the applicable operating band as specified in Table 6.2.2-1.

Table 6.2.5-1: P_{CMAX} tolerance

$P_{\text{CMAX},c}$ (dBm)	Tolerance $T(P_{\text{CMAX},c})$ (dB)
$23 < P_{\text{CMAX},c} \leq 33$	2.0
$21 \leq P_{\text{CMAX},c} \leq 23$	2.0
$20 \leq P_{\text{CMAX},c} < 21$	2.5
$19 \leq P_{\text{CMAX},c} < 20$	3.5
$18 \leq P_{\text{CMAX},c} < 19$	4.0
$13 \leq P_{\text{CMAX},c} < 18$	5.0
$8 \leq P_{\text{CMAX},c} < 13$	6.0
$-40 \leq P_{\text{CMAX},c} < 8$	7.0

For the UE which supports inter-band carrier aggregation configurations with the uplink assigned to one or two E-UTRA bands the $\Delta T_{\text{IB},c}$ is defined for applicable bands in Table 6.2.5-2 and Table 6.2.5-3.

Table 6.2.5-2: $\Delta T_{IB,c}$ (two bands)

Inter-band CA Configuration	E-UTRA Band	$\Delta T_{IB,c}$ [dB]
CA_1A-3A	1	0.3
	3	0.3
CA_1A-5A	1	0.3
	5	0.3
CA_1A-7A	1	0.5
	7	0.6
CA_1A-8A	1	0.3
	8	0.3
CA_1A-11A	1	0.3
	11	0.3
CA_1A-18A	1	0.3
	18	0.3
CA_1A-19A	1	0.3
	19	0.3
CA_1A-20A	1	0.3
	20	0.3
CA_1A-21A	1	0.3
	21	0.3
CA_1A-26A	1	0.3
	26	0.3
CA_1A-28A	1	0.3
	28	0.6
CA_1A-41A ^B	1	0.5
	41	0.5
CA_1A-41C ^B	1	0.5
	41	0.5
CA_1A-42A	1	0.3
	42	0.8
CA_1A-42C	1	0.3
	42	0.8
CA_2A-4A	2	0.5
	4	0.5
CA_2A-4A-4A	2	0.5
	4	0.5
CA_2A-5A	2	0.3
	5	0.3
CA_2A-2A-5A	2	0.3
	5	0.3
CA_2A-12A	2	0.3
	12	0.3
CA_2A-12B	2	0.3
	12	0.3
CA_2A-13A	2	0.3
	13	0.3
CA_2A-2A-13A	2	0.3
	13	0.3
CA_2A-17A	2	0.3
	17	0.8
CA_2A-29A	2	0.3
CA_2C-29A	2	0.3
CA_2A-30A	2	0.5
	30	0.3
CA_3A-5A	3	0.3
	5	0.3
CA_3A-7A	3	0.5
	7	0.5
CA_3A-7C	3	0.5
	7	0.5
CA_3C-7A	3	0.5
	7	0.5
CA_3A-8A	3	0.3

	8	0.3
CA_3A-19A	3	0.3
	19	0.3
CA_3A-20A	3	0.3
	20	0.3
CA_3A-26A	3	0.3
	26	0.3
CA_3A-27A	3	0.3
	27	0.3
CA_3A-28A	3	0.3
	28	0.3
CA_3A-42A	3	0.6
	42	0.8
CA_3A-42C	3	0.6
	42	0.8
CA_4A-5A	4	0.3
	5	0.3
CA_4A-4A-5A	4	0.3
	5	0.3
CA_4A-7A	4	0.5
	7	0.5
CA_4A-4A-7A	4	0.5
	7	0.5
CA_4A-12A	4	0.3
	12	0.8
CA_4A-4A-12A	4	0.3
	12	0.8
CA_4A-12B	4	0.3
	12	0.8
CA_4A-13A	4	0.3
	13	0.3
CA_4A-4A-13A	4	0.3
	13	0.3
CA_4A-17A	4	0.3
	17	0.8
CA_4A-27A	4	0.3
	27	0.3
CA_4A-29A	4	0.3
CA_4A-30A	4	0.5
	30	0.3
CA_5A-7A	5	0.3
	7	0.3
CA_5A-12A	5	0.8
	12	0.4
CA_5A-13A	5	0.5
	13	0.5
CA_5A-17A	5	0.8
	17	0.4
CA_5A-25A	5	0.3
	25	0.3
CA_5A-30A	5	0.3
	30	0.3
CA_7A-8A	7	0.3
	8	0.6
CA_7A-12A	7	0.3
	12	0.3
CA_7A-20A	7	0.3
	20	0.3
CA_7A-28A	7	0.3
	28	0.3
CA_8A-11A	8	0.3
	11	0.4
CA_8A-20A	8	0.4
	20	0.4
CA_8A-40A	8	0.3

	40	0.3
CA_11A-18A	11	0.3
	18	0.3
CA_12A-25A	12	0.3
	25	0.3
CA_12A-30A	12	0.3
	30	0.3
CA_18A-28A ⁹	18	0.5
	28	0.5
CA_19A-21A	19	0.3
	21	0.4
CA_19A-42A	19	0.3
	42	0.8
CA_19A-42C	19	0.3
	42	0.8
CA_20A-32A	20	0.3
CA_23A-29A	23	0.3
CA_25A-41A ⁸	25	0.5
	41	0.5
CA_25A-41C ⁸	25	0.5
	41	0.5
CA_26A-41A	26	0.3
	41	0.3
CA_26A-41C	26	0.3
	41	0.3
CA_29A-30A	30	0.3
CA_39A-41A	39	0 ⁴
	41	0 ⁴
CA_39A-41A	39	0.5 ⁷
	41	0.5 ⁷
CA_39A-41C	39	0 ⁴
	41	0 ⁴
CA_39C-41A	39	0 ⁴
	41	0 ⁴
CA_41A-42A	41	0 ⁴
	42	0.5 ⁴
<p>NOTE 1: The above additional tolerances are only applicable for the E-UTRA operating bands that belong to the supported inter-band carrier aggregation configurations</p> <p>NOTE 2: The above additional tolerances also apply in non-aggregated operation for the supported E-UTRA operating bands that belong to the supported inter-band carrier aggregation configurations</p> <p>NOTE 3: In case the UE supports more than one of the above 2DL inter-band carrier aggregation configurations and a E-UTRA operating band belongs to more than one 2DL inter-band carrier aggregation configurations then:</p> <ul style="list-style-type: none"> - When the E-UTRA operating band frequency range is ≤ 1GHz, the applicable additional tolerance shall be the average of the 2DL tolerances above, truncated to one decimal place for that operating band among the supported 2DL CA configurations. In case there is a harmonic relation between low band UL and high band DL, then the maximum tolerance among the different supported 2DL carrier aggregation configurations involving such band shall be applied - When the E-UTRA operating band frequency range is >1GHz, the applicable additional 2DL tolerance shall be the maximum tolerance above that applies for that operating band among the supported 2DL CA configurations <p>NOTE 4: Only applicable for UE supporting inter-band carrier aggregation with uplink in one E-UTRA band and without simultaneous Rx/Tx.</p> <p>NOTE 5: Unless otherwise specified, in case the UE supports more than one of the above 3DL inter-band carrier aggregation configurations and a E-UTRA operating band belongs to more than one 3DL inter-band carrier aggregation configurations then:</p> <ul style="list-style-type: none"> - When the E-UTRA operating band frequency range is ≤ 1GHz and the tolerances are the same, the value applies to the band. If the tolerances 		

<p>are different, the applicable additional 3DL tolerance is FFS. In case there is a harmonic relation between low band UL and high band DL, then the maximum tolerance among the different supported 3DL carrier aggregation configurations involving such band shall be applied</p> <ul style="list-style-type: none"> - When the E-UTRA operating band frequency range is >1GHz, the applicable additional 3DL tolerance shall be the maximum tolerance above that applies for that operating band among the supported 3DL CA configurations <p>NOTE 6: The above additional tolerances applicable for the E-UTRA operating bands that belong to the supported highest order inter-band carrier aggregation configuration, also applies to the same E-UTRA operating bands that belong to a supported lower order CA configuration.</p> <p>NOTE 7: Applicable for UE supporting inter-band carrier aggregation with two uplinks and without simultaneous Rx/Tx.</p> <p>NOTE 8: Only applicable for UE supporting inter-band carrier aggregation with the uplink active in the FDD band.</p> <p>NOTE 9: For Band 28, the requirements only apply for the restricted frequency range specified for this CA configuration (Table 5.5A-2).</p>

NOTE: The above additional tolerances do not apply to supported UTRA operating bands with frequency range below 1 GHz that correspond to the E-UTRA operating bands that belong to the supported inter-band carrier aggregation configurations when such bands are belonging only to band combination(s) where one band is <1GHz and another band is >1.7GHz and there is no harmonic relationship between the low band UL and high band DL. Otherwise the above additional tolerances also apply to supported UTRA operating bands that correspond to the E-UTRA operating bands that belong to the supported inter-band carrier aggregation configurations.

NOTE: To meet the $\Delta T_{IB,c}$ requirements for CA_3A-7A with state-of-the-art technology, an increase in power consumption of the UE may be required. It is also expected that as the state-of-the-art technology evolves in the future, this possible power consumption increase can be reduced or eliminated.

Table 6.2.5-3: $\Delta T_{IB,c}$ (three bands)

Inter-band CA Configuration	E-UTRA Band	$\Delta T_{IB,c}$ [dB]
CA_1A-3A-8A	1	0.3
	3	0.3
	8	0.3
CA_1A-3A-5A	1	0.3
	3	0.3
	5	0.3
CA_1A-3A-19A	1	0.3
	3	0.3
	19	0.3
CA_1A-3A-20A	1	0.3
	3	0.3
	20	0.3
CA_1A-3A-26A	1	0.3
	3	0.3
	26	0.3
CA_1A-5A-7A	1	0.5
	5	0.3
	7	0.6
CA_1A-7A-20A	1	0.5
	7	0.6
	20	0.3
CA_1A-18A-28A	1	0.3
	18	0.5
	28	0.5
CA_1A-19A-21A	1	0.3
	19	0.3
	21	0.4
CA_2A-4A-5A	2	0.5
	4	0.5
	5	0.3
CA_2A-4A-12A	2	0.5
	4	0.5
	12	0.8
CA_2A-4A-13A	2	0.5
	4	0.5
	13	0.3
CA_2A-4A-29A	2	[0.5]
	4	0.5
CA_2A-5A-12A	2	0.3
	5	0.8
	12	0.4
CA_2A-5A-13A	2	0.3
	5	0.5
	13	0.5
CA_2A-5A-30A	2	0.5
	5	0.3
	30	0.3
CA_2A-12A-30A	2	0.5
	12	0.3
	30	0.3
CA_2A-29A-30A	2	0.5
	30	0.3
CA_3A-7A-20A	3	0.5
	7	0.5
	20	0.3
CA_4A-5A-12A	4	0.3
	5	0.8
	12	0.8
CA_4A-5A-13A	4	0.3
	5	0.5
	13	0.5

CA_4A-5A-30A	4	0.5
	5	0.3
	30	0.3
CA_4A-7A-12A	4	0.5
	7	0.5
	12	0.8
CA_4A-12A-30A	4	0.5
	12	0.8
	30	0.3
CA_4A-29A-30A	4	0.5
	30	0.3
CA_7A-8A-20A	7	0.3
	8	0.6
	20	[0.6]
<p>NOTE 1: The above additional tolerances are only applicable for the E-UTRA operating bands that belong to the supported inter-band carrier aggregation configurations</p> <p>NOTE 2: The above additional tolerances also apply in non-aggregated operation for the supported E-UTRA operating bands that belong to the supported inter-band carrier aggregation configurations</p> <p>NOTE 3: Unless otherwise specified, in case the UE supports more than one of the above 3DL inter-band carrier aggregation configurations and a E-UTRA operating band belongs to more than one 3DL inter-band carrier aggregation configurations then:</p> <ul style="list-style-type: none"> - When the E-UTRA operating band frequency range is ≤ 1GHz and the tolerances are the same, the value applies to the band. If the tolerances are different, the applicable additional 3DL tolerance is FFS. In case there is a harmonic relation between low band UL and high band DL, then the maximum tolerance among the different supported 3DL carrier aggregation configurations involving such band shall be applied - When the E-UTRA operating band frequency range is >1GHz, the applicable additional 3DL tolerance shall be the maximum tolerance above that applies for that operating band among the supported 3DL CA configurations <p>NOTE 4: The above additional tolerances applicable for the E-UTRA operating bands that belong to the supported highest order inter-band carrier aggregation configuration, also applies to the same E-UTRA operating bands that belong to a supported lower order CA configuration.</p>		

NOTE: The above additional tolerances do not apply to supported UTRA operating bands with frequency range below 1 GHz that correspond to the E-UTRA operating bands that belong to the supported inter-band carrier aggregation configurations when such bands are belonging only to band combination(s) where one band is <1 GHz and other bands are >1.7 GHz and there is no harmonic relationship between the low band UL and high band DL. Otherwise the above additional tolerances also apply to supported UTRA operating bands that correspond to the E-UTRA operating bands that belong to the supported inter-band carrier aggregation configurations.

6.2.5A Configured transmitted power for CA

For uplink carrier aggregation the UE is allowed to set its configured maximum output power $P_{\text{CMAX},c}$ for serving cell c and its total configured maximum output power P_{CMAX} .

The configured maximum output power $P_{\text{CMAX},c}$ on serving cell c shall be set as specified in subclause 6.2.5.

For uplink inter-band carrier aggregation, MPR_c and A-MPR_c apply per serving cell c and are specified in subclause 6.2.3 and subclause 6.2.4, respectively. P-MPR_c accounts for power management for serving cell c . $P_{\text{CMAX},c}$ is calculated under the assumption that the transmit power is increased independently on all component carriers.

For uplink intra-band contiguous and non-contiguous carrier aggregation, $\text{MPR}_c = \text{MPR}$ and $\text{A-MPR}_c = \text{A-MPR}$ with MPR and A-MPR specified in subclause 6.2.3A and subclause 6.2.4A respectively. There is one power management term for the UE, denoted P-MPR , and $\text{P-MPR}_c = \text{P-MPR}$. $P_{\text{CMAX},c}$ is calculated under the assumption that the transmit power is increased by the same amount in dB on all component carriers.

The total configured maximum output power P_{CMAX} shall be set within the following bounds:

$$P_{\text{CMAX_L}} \leq P_{\text{CMAX}} \leq P_{\text{CMAX_H}}$$

For uplink inter-band carrier aggregation with one serving cell c per operating band,

$$P_{\text{CMAX_L}} = \text{MIN} \{ 10 \log_{10} \sum \text{MIN} [p_{\text{EMAX},c} / (\Delta t_{\text{C},c}), p_{\text{PowerClass}} / (\text{mpr}_c \cdot \text{a-mpr}_c \cdot \Delta t_{\text{C},c} \cdot \Delta t_{\text{IB},c} \cdot \Delta t_{\text{ProSe}}), p_{\text{PowerClass}} / \text{pmpr}_c], P_{\text{PowerClass}} \}$$

$$P_{\text{CMAX_H}} = \text{MIN} \{ 10 \log_{10} \sum p_{\text{EMAX},c}, P_{\text{PowerClass}} \}$$

where

- $p_{\text{EMAX},c}$ is the linear value of $P_{\text{EMAX},c}$ which is given by IE *P-Max* for serving cell c in [7];
- $P_{\text{PowerClass}}$ is the maximum UE power specified in Table 6.2.2A-1 without taking into account the tolerance specified in the Table 6.2.2A-1; $p_{\text{PowerClass}}$ is the linear value of $P_{\text{PowerClass}}$;
- mpr_c and a-mpr_c are the linear values of MPR_c and A-MPR_c as specified in subclause 6.2.3 and subclause 6.2.4, respectively;
- pmpr_c is the linear value of P-MPR_c ;
- $\Delta t_{\text{C},c}$ is the linear value of $\Delta T_{\text{C},c}$. $\Delta t_{\text{C},c} = 1.41$ when Note 2 in Table 6.2.2-1 applies for a serving cell c , otherwise $\Delta t_{\text{C},c} = 1$;
- $\Delta t_{\text{IB},c}$ is the linear value of the inter-band relaxation term $\Delta T_{\text{IB},c}$ of the serving cell c as specified in Table 6.2.5-2; otherwise $\Delta t_{\text{IB},c} = 1$;
- Δt_{ProSe} is the linear value of ΔT_{ProSe} and applies as specified in subclause 6.2.5.

For uplink intra-band contiguous and non-contiguous carrier aggregation,

$$P_{\text{CMAX_L}} = \text{MIN} \{ 10 \log_{10} \sum p_{\text{EMAX},c} - \Delta T_{\text{C}}, P_{\text{PowerClass}} - \text{MAX}(\text{MPR} + \text{A-MPR} + \Delta T_{\text{IB},c} + \Delta T_{\text{C}} + \Delta T_{\text{ProSe}}, \text{P-MPR}) \}$$

$$P_{\text{CMAX_H}} = \text{MIN} \{ 10 \log_{10} \sum p_{\text{EMAX},c}, P_{\text{PowerClass}} \}$$

where

- $p_{\text{EMAX},c}$ is the linear value of $P_{\text{EMAX},c}$ which is given by IE *P-Max* for serving cell c in [7];
- $P_{\text{PowerClass}}$ is the maximum UE power specified in Table 6.2.2A-1 without taking into account the tolerance specified in the Table 6.2.2A-1;
- MPR and A-MPR are specified in subclause 6.2.3A and subclause 6.2.4A respectively;
- $\Delta T_{\text{IB},c}$ is the additional tolerance for serving cell c as specified in Table 6.2.5-2;
- P-MPR is the power management term for the UE;
- ΔT_{C} is the highest value $\Delta T_{\text{C},c}$ among all serving cells c in the subframe over both timeslots. $\Delta T_{\text{C},c} = 1.5$ dB when Note 2 in Table 6.2.2A-1 applies to the serving cell c , otherwise $\Delta T_{\text{C},c} = 0$ dB;
- ΔT_{ProSe} applies as specified in subclause 6.2.5.

For each subframe, the $P_{\text{CMAX_L}}$ is evaluated per slot and given by the minimum value taken over the transmission(s) within the slot; the minimum $P_{\text{CMAX_L}}$ over the two slots is then applied for the entire subframe. $P_{\text{PowerClass}}$ shall not be exceeded by the UE during any period of time.

If the UE is configured with multiple TAGs and transmissions of the UE on subframe i for any serving cell in one TAG overlap some portion of the first symbol of the transmission on subframe $i + 1$ for a different serving cell in another TAG, the UE minimum of P_{CMAX_L} for subframes i and $i + 1$ applies for any overlapping portion of subframes i and $i + 1$. $P_{\text{PowerClass}}$ shall not be exceeded by the UE during any period of time.

In case PC2 and uplink intra-band contiguous CA capable UE receives p_{EMAX_c} in Scell then that applies both to Scell and Pcell once the Scell is activated.

The measured maximum output power P_{UMAX} over all serving cells shall be within the following range:

$$P_{\text{CMAX}_L} - \text{MAX}\{T_L, T_{\text{LOW}}(P_{\text{CMAX}_L})\} \leq P_{\text{UMAX}} \leq P_{\text{CMAX}_H} + T_{\text{HIGH}}(P_{\text{CMAX}_H})$$

$$P_{\text{UMAX}} = 10 \log_{10} \sum p_{\text{UMAX}_c}$$

where p_{UMAX_c} denotes the measured maximum output power for serving cell c expressed in linear scale. The tolerances $T_{\text{LOW}}(P_{\text{CMAX}})$ and $T_{\text{HIGH}}(P_{\text{CMAX}})$ for applicable values of P_{CMAX} are specified in Table 6.2.5A-1 and Table 6.2.5A-2 for inter-band carrier aggregation and intra-band carrier aggregation, respectively. The tolerance T_L is the absolute value of the lower tolerance for applicable E-UTRA CA configuration as specified in Table 6.2.2A-0, Table 6.2.2A-1 and Table 6.2.2A-2 for inter-band carrier aggregation, intra-band contiguous carrier aggregation and intra-band non-contiguous carrier aggregation, respectively.

Table 6.2.5A-1: P_{CMAX} tolerance for uplink inter-band CA (two bands)

P_{CMAX} (dBm)	Tolerance $T_{\text{LOW}}(P_{\text{CMAX}})$ (dB)	Tolerance $T_{\text{HIGH}}(P_{\text{CMAX}})$ (dB)
$P_{\text{CMAX}} = 23$	3.0	2.0
$22 \leq P_{\text{CMAX}} < 23$	5.0	2.0
$21 \leq P_{\text{CMAX}} < 22$	5.0	3.0
$20 \leq P_{\text{CMAX}} < 21$	6.0	4.0
$16 \leq P_{\text{CMAX}} < 20$	5.0	
$11 \leq P_{\text{CMAX}} < 16$	6.0	
$-40 \leq P_{\text{CMAX}} < 11$	7.0	

Table 6.2.5A-2: P_{CMAX} tolerance

P_{CMAX} (dBm)	Tolerance $T_{\text{LOW}}(P_{\text{CMAX}})$ (dB)	Tolerance $T_{\text{HIGH}}(P_{\text{CMAX}})$ (dB)
$21 \leq P_{\text{CMAX}} \leq 23$	2.0	
$20 \leq P_{\text{CMAX}} < 21$	2.5	
$19 \leq P_{\text{CMAX}} < 20$	3.5	
$18 \leq P_{\text{CMAX}} < 19$	4.0	
$13 \leq P_{\text{CMAX}} < 18$	5.0	
$8 \leq P_{\text{CMAX}} < 13$	6.0	
$-40 \leq P_{\text{CMAX}} < 8$	7.0	

6.2.5B Configured transmitted power for UL-MIMO

For UE supporting UL-MIMO, the transmitted power is configured per each UE.

The definitions of configured maximum output power P_{CMAX_c} , the lower bound $P_{\text{CMAX}_L,c}$, and the higher bound $P_{\text{CMAX}_H,c}$ specified in subclause 6.2.5 shall apply to UE supporting UL-MIMO, where

- $P_{\text{PowerClass}}$ and $\Delta T_{C,c}$ are specified in subclause 6.2.2B;
- MPR_c is specified in subclause 6.2.3B;
- A-MPR_c is specified in subclause 6.2.4B.

The measured configured maximum output power P_{UMAX_c} for serving cell c shall be within the following bounds:

$$P_{\text{CMAX_L},c} - \text{MAX}\{T_L, T_{\text{LOW}}(P_{\text{CMAX_L},c})\} \leq P_{\text{UMAX},c} \leq P_{\text{CMAX_H},c} + T_{\text{HIGH}}(P_{\text{CMAX_H},c})$$

where $T_{\text{LOW}}(P_{\text{CMAX_L},c})$ and $T_{\text{HIGH}}(P_{\text{CMAX_H},c})$ are defined as the tolerance and applies to $P_{\text{CMAX_L},c}$ and $P_{\text{CMAX_H},c}$ separately, while T_L is the absolute value of the lower tolerance in Table 6.2.2B-1 for the applicable operating band.

For UE with two transmit antenna connectors in closed-loop spatial multiplexing scheme, the tolerance is specified in Table 6.2.5B-1. The requirements shall be met with UL-MIMO configurations specified in Table 6.2.2B-2.

Table 6.2.5B-1: $P_{\text{CMAX},c}$ tolerance in closed-loop spatial multiplexing scheme

$P_{\text{CMAX},c}$ (dBm)	Tolerance $T_{\text{LOW}}(P_{\text{CMAX_L},c})$ (dB)	Tolerance $T_{\text{HIGH}}(P_{\text{CMAX_H},c})$ (dB)
$P_{\text{CMAX},c} = 23$	3.0	2.0
$22 \leq P_{\text{CMAX},c} < 23$	5.0	2.0
$21 \leq P_{\text{CMAX},c} < 22$	5.0	3.0
$20 \leq P_{\text{CMAX},c} < 21$	6.0	4.0
$16 \leq P_{\text{CMAX},c} < 20$	5.0	
$11 \leq P_{\text{CMAX},c} < 16$	6.0	
$-40 \leq P_{\text{CMAX},c} < 11$	7.0	

If UE is configured for transmission on single-antenna port, the requirements in subclause 6.2.5 apply.

6.2.5C Configured transmitted power for Dual Connectivity

For inter-band dual connectivity with one uplink serving cell per CG, the UE is allowed to set its configured maximum output power $P_{\text{CMAX},c(i),i}$ for serving cell $c(i)$ of CG i , $i = 1, 2$, and its total configured maximum output power P_{CMAX} .

The configured maximum output power $P_{\text{CMAX},c(i),i}(p)$ in subframe p of serving cell $c(i)$ on CG i shall be set within the following bounds:

$$P_{\text{CMAX_L},c(i),i}(p) \leq P_{\text{CMAX},c(i),i}(p) \leq P_{\text{CMAX_H},c(i),i}(p)$$

where $P_{\text{CMAX_L},c(i),i}(p)$ and $P_{\text{CMAX_H},c(i),i}(p)$ are the limits for a serving cell $c(i)$ of CG i as specified in subclause 6.2.5.

The total UE configured maximum output power $P_{\text{CMAX}}(p,q)$ in a subframe p of CG 1 and a subframe q of CG 2 that overlap in time shall be set within the following bounds for synchronous and asynchronous operation unless stated otherwise:

$$P_{\text{CMAX_L}}(p,q) \leq P_{\text{CMAX}}(p,q) \leq P_{\text{CMAX_H}}(p,q)$$

with

$$P_{\text{CMAX_L}}(p,q) = \text{MIN}\{10 \log_{10} [p_{\text{CMAX_L},c(1),1}(p) + p_{\text{CMAX_L},c(2),2}(q)], P_{\text{PowerClass}}\}$$

$$P_{\text{CMAX_H}}(p,q) = \text{MIN}\{10 \log_{10} [p_{\text{CMAX_H},c(1),1}(p) + p_{\text{CMAX_H},c(2),2}(q)], P_{\text{PowerClass}}\}$$

where $p_{\text{CMAX_L},c(i),i}$ is $p_{\text{CMAX_H},c(i),i}$ are the respective limits $P_{\text{CMAX_L},c(i),i}(p)$ and $P_{\text{CMAX_H},c(i),i}(p)$ expressed in linear scale.

If the UE is configured in Dual Connectivity and synchronous transmissions of the UE on subframe p for a serving cell in one CG overlaps some portion of the first symbol of the transmission on subframe $q+1$ for a different serving cell in the other CG, the UE minimum of $P_{\text{CMAX_L}}$ between subframes pairs (p, q) and $(p+1, q+1)$ respectively applies for any overlapping portion of subframes (p, q) and $(p+1, q+1)$. $P_{\text{PowerClass}}$ shall not be exceeded by the UE during any period of time.

The measured total maximum output power P_{UMAX} over both CGs is

$$P_{\text{UMAX}} = 10 \log_{10} [p_{\text{UMAX},c(1),1} + p_{\text{UMAX},c(2),2}],$$

where $p_{\text{UMAX},c(i),i}$ denotes the measured output power of serving cell $c(i)$ of CG i expressed in linear scale.

If the UE is configured in Dual Connectivity and synchronous transmissions

$$P_{\text{CMAX_L}}(p, q) - T_{\text{LOW}}(P_{\text{CMAX_L}}(p, q)) \leq P_{\text{UMAX}} \leq P_{\text{CMAX_H}}(p, q) + T_{\text{HIGH}}(P_{\text{CMAX_H}}(p, q))$$

where $P_{\text{CMAX_L}}(p,q)$ and $P_{\text{CMAX_H}}(p,q)$ are the limits for the pair (p,q) and with the tolerances $T_{\text{LOW}}(P_{\text{CMAX}})$ and $T_{\text{HIGH}}(P_{\text{CMAX}})$ for applicable values of P_{CMAX} specified in Table 6.2.5C-1. $P_{\text{CMAX_L}}$ may be modified for any overlapping portion of subframes (p, q) and $(p+1, q+1)$.

If the UE is configured in Dual Connectivity and asynchronous transmissions, the subframes of the leading CG are taken as reference subframes for the measurement of the total configured output power P_{UMAX} . If subframe p of CG 1 and subframe q of CG 2 overlap in time in their respective slot 0 and

1. if p leads in time over q , then p is the reference subframe and the (p,q) and $(p,q-1)$ pairs are considered for determining the P_{CMAX} tolerance
2. if q leads in time over p , then q is the reference subframe and the $(p-1,q)$ and (p,q) pairs are considered for determining the P_{CMAX} tolerance;

for the reference subframe p duration (when subframe p in CG 1 leads):

$$P'_{\text{CMAX_L}} = \text{MIN} \{P_{\text{CMAX_L}}(p,q), P_{\text{CMAX_L}}(p,q-1)\}$$

$$P'_{\text{CMAX_H}} = \text{MAX} \{P_{\text{CMAX_H}}(p,q), P_{\text{CMAX_H}}(p,q-1)\}$$

while for the reference subframe q duration (when subframe q in CG 2 leads):

$$P'_{\text{CMAX_L}} = \text{MIN} \{P_{\text{CMAX_L}}(p-1,q), P_{\text{CMAX_L}}(p,q)\}$$

$$P'_{\text{CMAX_H}} = \text{MAX} \{P_{\text{CMAX_H}}(p-1,q), P_{\text{CMAX_H}}(p,q)\}$$

where $P_{\text{CMAX_L}}$ and $P_{\text{CMAX_H}}$ are the applicable limits for each overlapping subframe pairs (p,q) , $(p, q-1)$, $(p-1,q)$. The measured total configured maximum output power P_{UMAX} shall be within the following bounds:

$$P'_{\text{CMAX_L}} - T_{\text{LOW}}(P'_{\text{CMAX_L}}) \leq P_{\text{UMAX}} \leq P'_{\text{CMAX_H}} + T_{\text{HIGH}}(P'_{\text{CMAX_H}})$$

with the tolerances $T_{\text{LOW}}(P_{\text{CMAX}})$ and $T_{\text{HIGH}}(P_{\text{CMAX}})$ for applicable values of P_{CMAX} specified in Table 6.2.5C-1.

Table 6.2.5C-1: P_{CMAX} tolerance for inter-band Dual Connectivity

$P_{\text{CMAX}}(\text{dBm})$	Tolerance $T_{\text{LOW}}(P_{\text{CMAX_L}})(\text{dB})$	Tolerance $T_{\text{HIGH}}(P_{\text{CMAX_H}})(\text{dB})$
$P_{\text{CMAX}} = 23$	3.0	2.0
$22 \leq P_{\text{CMAX}} < 23$	5.0	2.0
$21 \leq P_{\text{CMAX}} < 22$	5.0	3.0
$20 \leq P_{\text{CMAX}} < 21$	6.0	4.0
$16 \leq P_{\text{CMAX}} < 20$	5.0	
$11 \leq P_{\text{CMAX}} < 16$	6.0	
$-40 \leq P_{\text{CMAX}} < 11$	7.0	

6.2.5D Configured transmitted power for ProSe

The configured maximum output power $P_{\text{CMAX},c}$ and power boundary requirement specified in subclause 6.2.5 shall apply to UE supporting ProSe, where

- MPR_c is specified in subclause 6.2.3D;
- A-MPR_c is specified in subclause 6.2.4D;
- $\Delta T_{\text{ProSe}} = 0.1$ dB.

For $P_{\text{CMAX},\text{PSSCH}}$ and $P_{\text{CMAX},\text{PSCCH}}$, $P_{\text{EMAX},c}$ is the value given by IE *P-Max* for serving cell c , defined by [7], when present. $P_{\text{EMAX},c}$ is the value given by IE *maxTxPower*, defined by [7], when the UE is not associated with a serving cell on the ProSe carrier.

For $P_{\text{CMAX},\text{PSDCH}}$, $P_{\text{EMAX},c}$ is the value given by the IE *discMaxTxPower* in [7].

For $P_{\text{CMAX,PSBCH}}$, $P_{\text{EMAX,c}}$ is the value given by the IE *maxTxPower* in [7] when the ProSe UE is not associated with a serving cell on the ProSe carrier. When the UE is associated with a serving cell, then $P_{\text{EMAX,c}}$ is the value given by the IE *P-Max* when PSBCH/SLSS transmissions is triggered for ProSe Direct communication as specified in [7], and is the value given by the IE *discMaxTxPower* in [7] otherwise.

For $P_{\text{CMAX,SSSS}}$, the value is as calculated for $P_{\text{CMAX,PSBCH}}$ and applying the MPR for SSSS as specified in Section 6.2.3D.

6.3 Output power dynamics

6.3.1 (Void)

6.3.2 Minimum output power

The minimum controlled output power of the UE is defined as the broadband transmit power of the UE, i.e. the power in the channel bandwidth for all transmit bandwidth configurations (resource blocks), when the power is set to a minimum value.

6.3.2.1 Minimum requirement

The minimum output power is defined as the mean power in one sub-frame (1ms). The minimum output power shall not exceed the values specified in Table 6.3.2.1-1.

Table 6.3.2.1-1: Minimum output power

	Channel bandwidth / Minimum output power / Measurement bandwidth					
	1.4 MHz	3.0 MHz	5 MHz	10 MHz	15 MHz	20 MHz
Minimum output power	-40 dBm					
Measurement bandwidth	1.08 MHz	2.7 MHz	4.5 MHz	9.0 MHz	13.5 MHz	18 MHz

6.3.2A UE Minimum output power for CA

For inter-band carrier aggregation with uplink assigned to two E-UTRA bands and intra-band contiguous and non-contiguous carrier aggregation, the minimum controlled output power of the UE is defined as the transmit power of the UE per component carrier, i.e., the power in the channel bandwidth of each component carrier for all transmit bandwidth configurations (resource blocks), when the power on both component carriers are set to a minimum value.

6.3.2A.1 Minimum requirement for CA

For inter-band carrier aggregation with uplink assigned to two E-UTRA bands, the minimum output power is defined per carrier and the requirement is specified in subclause 6.3.2.1.

For intra-band contiguous and non-contiguous carrier aggregation the minimum output power is defined as the mean power in one sub-frame (1ms). The minimum output power shall not exceed the values specified in Table 6.3.2A.1-1.

Table 6.3.2A.1-1: Minimum output power for intra-band contiguous and non-contiguous CA UE

	CC Channel bandwidth / Minimum output power / Measurement bandwidth					
	1.4 MHz	3.0 MHz	5 MHz	10 MHz	15 MHz	20 MHz
Minimum output power	-40 dBm					
Measurement bandwidth			4.5 MHz	9.0 MHz	13.5 MHz	18 MHz

6.3.2B UE Minimum output power for UL-MIMO

For UE supporting UL-MIMO, the minimum controlled output power is defined as the broadband transmit power of the UE, i.e. the sum of the power in the channel bandwidth for all transmit bandwidth configurations (resource blocks) at each transmit antenna connector, when the UE power is set to a minimum value.

6.3.2B.1 Minimum requirement

For UE with two transmit antenna connectors in closed-loop spatial multiplexing scheme, the minimum output power is defined as the sum of the mean power at each transmit connector in one sub-frame (1ms). The minimum output power shall not exceed the values specified in Table 6.3.2B.1-1.

Table 6.3.2B.1-1: Minimum output power

	Channel bandwidth / Minimum output power / Measurement bandwidth					
	1.4 MHz	3.0 MHz	5 MHz	10 MHz	15 MHz	20 MHz
Minimum output power	-40 dBm					
Measurement bandwidth	1.08 MHz	2.7 MHz	4.5 MHz	9.0 MHz	13.5 MHz	18 MHz

If UE is configured for transmission on single-antenna port, the requirements in subclause 6.3.2 apply.

6.3.3 Transmit OFF power

Transmit OFF power is defined as the mean power when the transmitter is OFF. The transmitter is considered to be OFF when the UE is not allowed to transmit or during periods when the UE is not transmitting a sub-frame. During DTX and measurements gaps, the UE is not considered to be OFF.

6.3.3.1 Minimum requirement

The transmit OFF power is defined as the mean power in a duration of at least one sub-frame (1ms) excluding any transient periods. The transmit OFF power shall not exceed the values specified in Table 6.3.3.1-1.

Table 6.3.3.1-1: Transmit OFF power

	Channel bandwidth / Transmit OFF power / Measurement bandwidth					
	1.4 MHz	3.0 MHz	5 MHz	10 MHz	15 MHz	20 MHz
Transmit OFF power	-50 dBm					
Measurement bandwidth	1.08 MHz	2.7 MHz	4.5 MHz	9.0 MHz	13.5 MHz	18 MHz

6.3.3A UE Transmit OFF power for CA

For inter-band carrier aggregation with uplink assigned to two E-UTRA bands and intra-band contiguous and non-contiguous carrier aggregation, transmit OFF power is defined as the mean power per component carrier when the transmitter is OFF on all component carriers. The transmitter is considered to be OFF when the UE is not allowed to transmit or during periods when the UE is not transmitting a sub-frame. During measurements gaps, the UE is not considered to be OFF.

6.3.3A.1 Minimum requirement for CA

For inter-band carrier aggregation with uplink assigned to two E-UTRA bands, transmit OFF power requirement is defined per carrier and the requirement is specified in subclause 6.3.3.1.

For intra-band contiguous and non-contiguous carrier aggregation the transmit OFF power is defined as the mean power in a duration of at least one sub-frame (1ms) excluding any transient periods. The transmit OFF power shall not exceed the values specified in Table 6.3.3A.1-1.

Table 6.3.3A.1-1: Transmit OFF power for intra-band contiguous and non-contiguous CA UE

	CC Channel bandwidth / Transmit OFF power / Measurement bandwidth					
	1.4 MHz	3.0 MHz	5 MHz	10 MHz	15 MHz	20 MHz
Transmit OFF power	-50 dBm					
Measurement bandwidth			4.5 MHz	9.0 MHz	13.5 MHz	18 MHz

6.3.3B UE Transmit OFF power for UL-MIMO

For UE supporting UL-MIMO, the transmit OFF power is defined as the mean power at each transmit antenna connector when the transmitter is OFF at all transmit antenna connectors. The transmitter is considered to be OFF when the UE is not allowed to transmit or during periods when the UE is not transmitting a sub-frame. During DTX and measurements gaps, the UE is not considered to be OFF.

6.3.3B.1 Minimum requirement

The transmit OFF power is defined as the mean power at each transmit antenna connector in a duration of at least one sub-frame (1ms) excluding any transient periods. The transmit OFF power at each transmit antenna connector shall not exceed the values specified in Table 6.3.3B.1-1.

Table 6.3.3B.1-1: Transmit OFF power per antenna port

	Channel bandwidth / Transmit OFF power/ Measurement bandwidth					
	1.4 MHz	3.0 MHz	5 MHz	10 MHz	15 MHz	20 MHz
Transmit OFF power	-50 dBm					
Measurement bandwidth	1.08 MHz	2.7 MHz	4.5 MHz	9.0 MHz	13.5 MHz	18 MHz

6.3.3D Transmit OFF power for ProSe

The ProSe UE shall Transmit OFF power at all times when the UE is not associated with PCell on the ProSe carrier and does not have knowledge of its geographical area or is provisioned with pre-configured radio parameters that are not associated with any known Geographical Area.

The requirements specified in subclause 6.3.3D shall apply to UE supporting ProSe when

- the UE is associated with PCell on the ProSe carrier, or
- the UE is not associated with PCell on the ProSe carrier and is provisioned with the preconfigured radio parameters for ProSe Direct Communications that are associated with known Geographical Area.

6.3.4 ON/OFF time mask

6.3.4.1 General ON/OFF time mask

The General ON/OFF time mask defines the observation period between Transmit OFF and ON power and between Transmit ON and OFF power. ON/OFF scenarios include; the beginning or end of DTX, measurement gap, contiguous, and non contiguous transmission

The OFF power measurement period is defined in a duration of at least one sub-frame excluding any transient periods. The ON power is defined as the mean power over one sub-frame excluding any transient period.

There are no additional requirements on UE transmit power beyond that which is required in subclause 6.2.2 and subclause 6.6.2.3

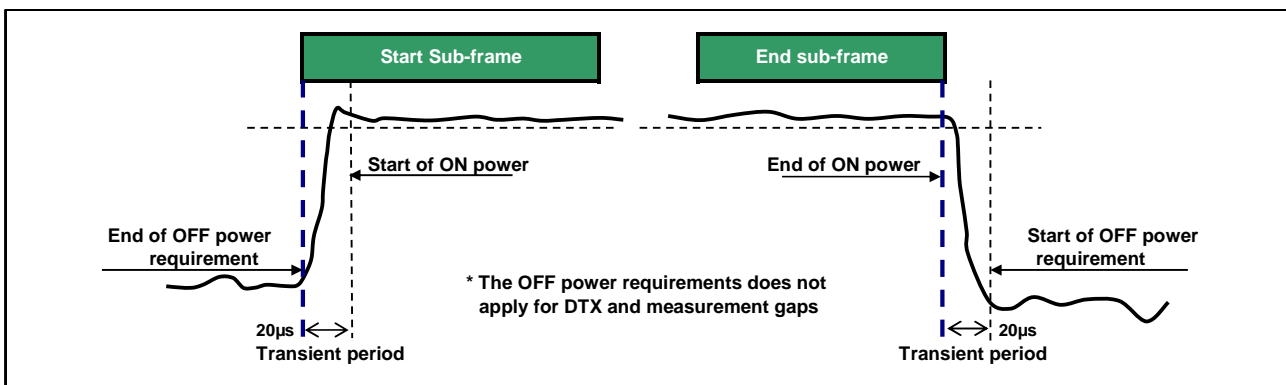

Figure 6.3.4.1-1: General ON/OFF time mask

6.3.4.2 PRACH and SRS time mask

6.3.4.2.1 PRACH time mask

The PRACH ON power is specified as the mean power over the PRACH measurement period excluding any transient periods as shown in Figure 6.3.4.2-1. The measurement period for different PRACH preamble format is specified in Table 6.3.4.2-1.

There are no additional requirements on UE transmit power beyond that which is required in subclause 6.2.2 and subclause 6.6.2.3

Table 6.3.4.2-1: PRACH ON power measurement period

PRACH preamble format	Measurement period (ms)
0	0.9031
1	1.4844
2	1.8031
3	2.2844
4	0.1479

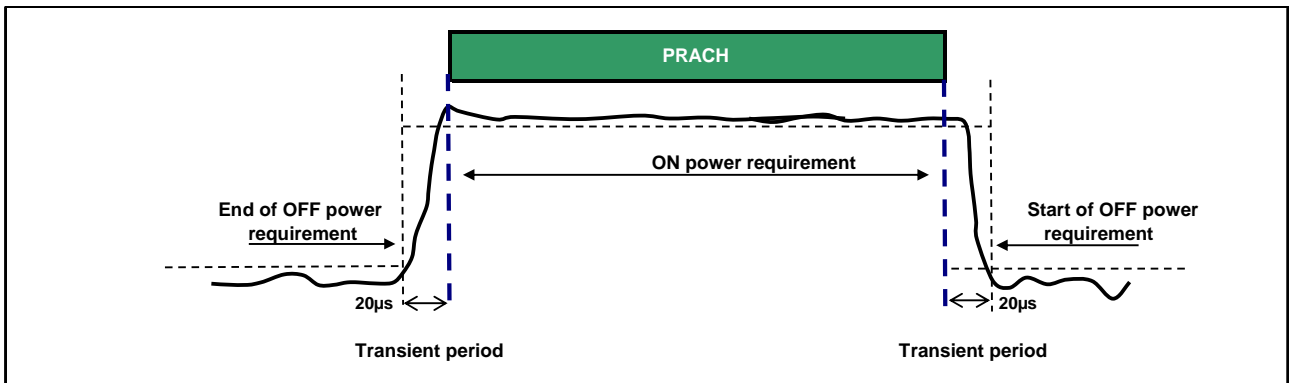

Figure 6.3.4.2-1: PRACH ON/OFF time mask

6.3.4.2.2 SRS time mask

In the case a single SRS transmission, the ON power is defined as the mean power over the symbol duration excluding any transient period. Figure 6.3.4.2.2-1

In the case a dual SRS transmission, the ON power is defined as the mean power for each symbol duration excluding any transient period. Figure 6.3.4.2.2-2

There are no additional requirements on UE transmit power beyond that which is required in subclause 6.2.2 and subclause 6.6.2.3

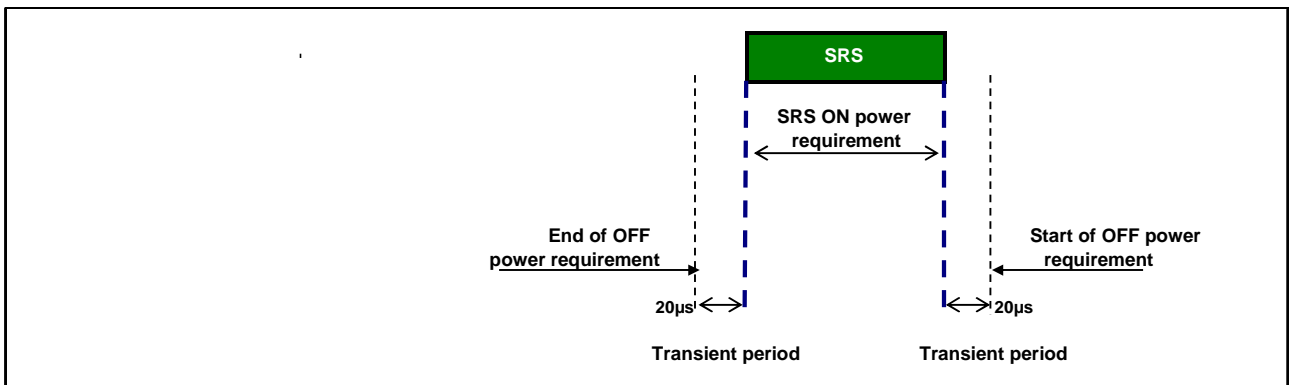

Figure 6.3.4.2.2-1: Single SRS time mask

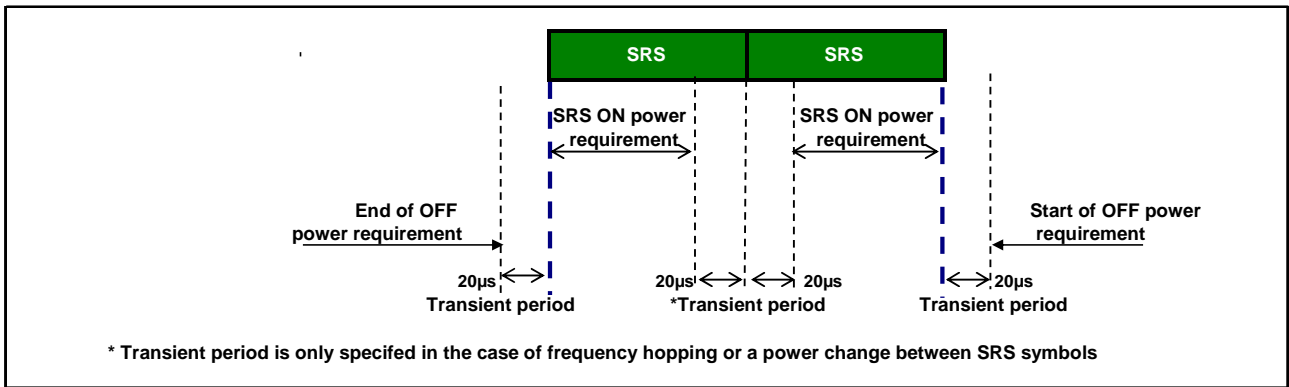

Figure 6.3.4.2.2: Dual SRS time mask for the case of UpPTS transmissions

6.3.4.3 Slot / Sub frame boundary time mask

The sub frame boundary time mask defines the observation period between the previous/subsequent sub-frame and the (reference) sub-frame. A transient period at a slot boundary within a sub-frame is only allowed in the case of Intra-sub frame frequency hopping. For the cases when the subframe contains SRS the time masks in subclause 6.3.4.4 apply.

There are no additional requirements on UE transmit power beyond that which is required in subclause 6.2.2 and subclause 6.6.2.3

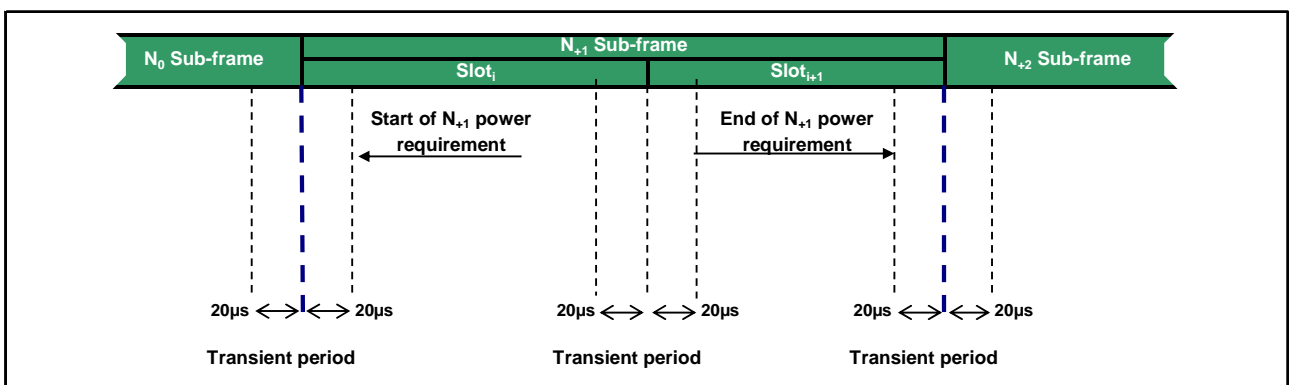

Figure 6.3.4.3-1: Transmission power template

6.3.4.4 PUCCH / PUSCH / SRS time mask

The PUCCH/PUSCH/SRS time mask defines the observation period between sounding reference symbol (SRS) and an adjacent PUSCH/PUCCH symbol and subsequent sub-frame.

There are no additional requirements on UE transmit power beyond that which is required in subclause 6.2.2 and subclause 6.6.2.3

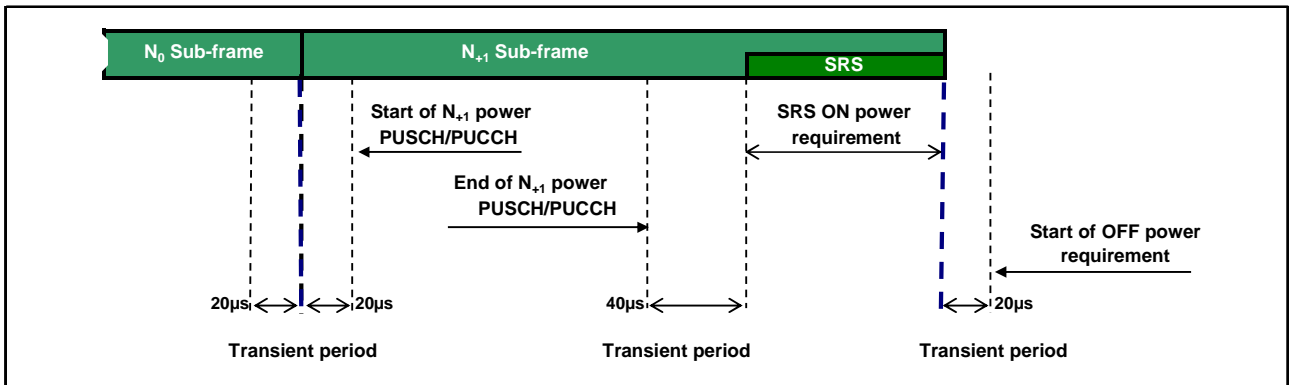

Figure 6.3.4.4-1: PUCCH/PUSCH/SRS time mask when there is a transmission before SRS but not after

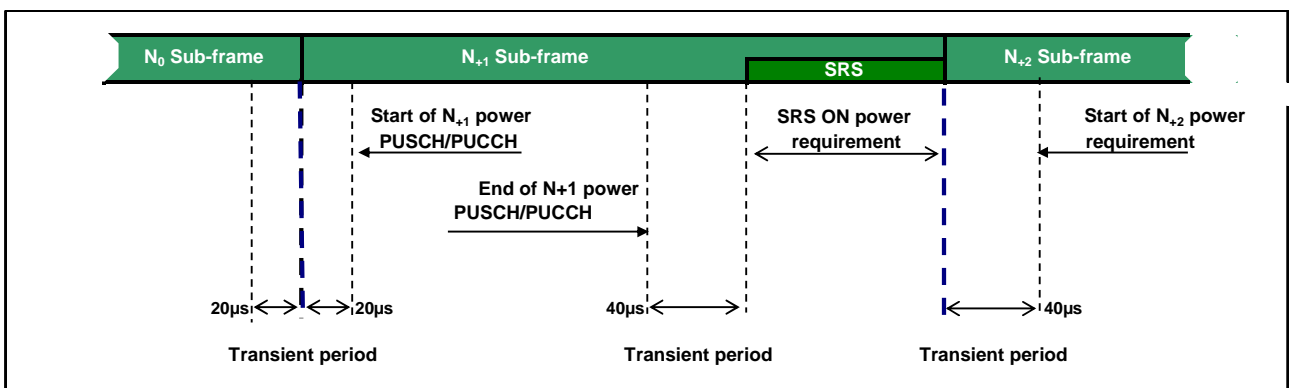

Figure 6.3.4.4-2: PUCCH/PUSCH/SRS time mask when there is transmission before and after SRS

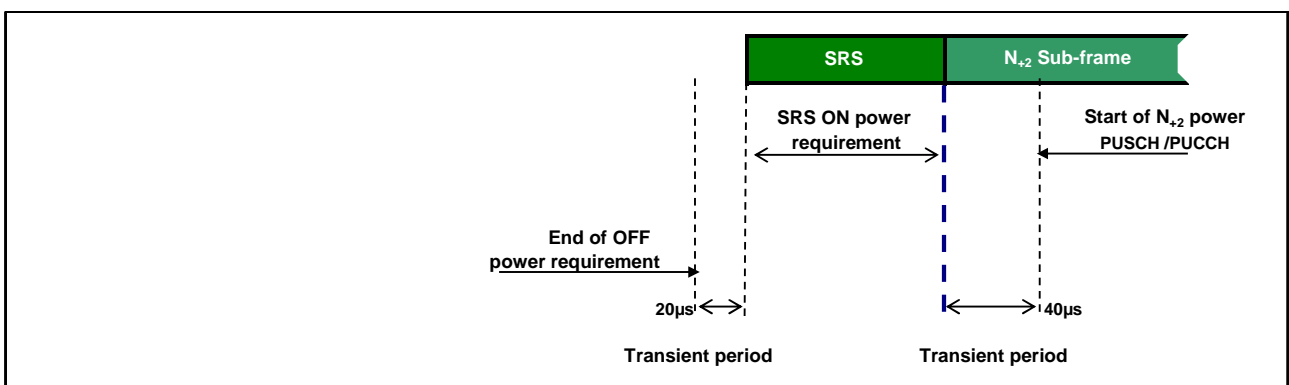

Figure 6.3.4.4-3: PUCCH/PUSCH/SRS time mask when there is a transmission after SRS but not before

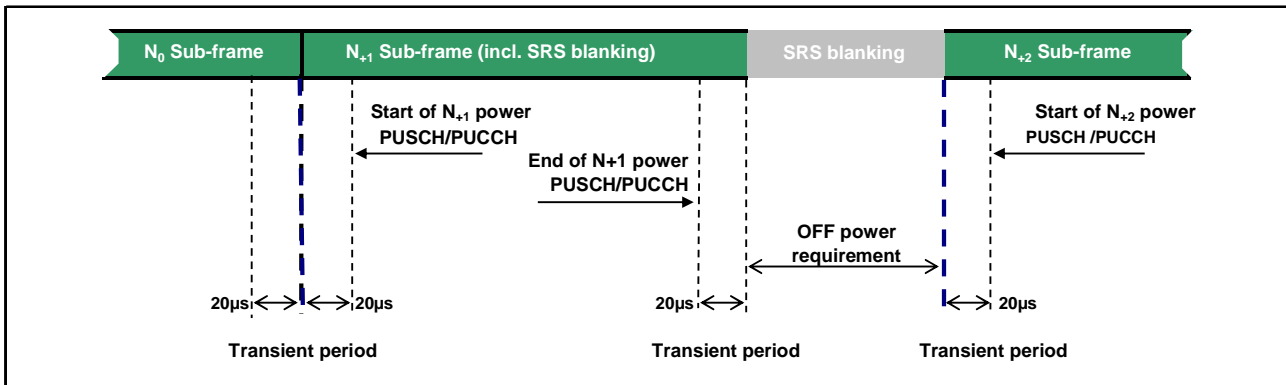

Figure 6.3.4.4-4: SRS time mask when there is FDD SRS blanking

6.3.4A ON/OFF time mask for CA

For inter-band carrier aggregation with uplink assigned to two E-UTRA bands and intra-band contiguous and non-contiguous carrier aggregation, the general output power ON/OFF time mask specified in subclause 6.3.4.1 is applicable for each component carrier during the ON power period and the transient periods. The OFF period as specified in subclause 6.3.4.1 shall only be applicable for each component carrier when all the component carriers are OFF.

6.3.4B ON/OFF time mask for UL-MIMO

For UE supporting UL-MIMO, the ON/OFF time mask requirements in subclause 6.3.4 apply at each transmit antenna connector.

For UE with two transmit antenna connectors in closed-loop spatial multiplexing scheme, the general ON/OFF time mask requirements specified in subclause 6.3.4.1 apply to each transmit antenna connector. The requirements shall be met with the UL-MIMO configurations specified in Table 6.2.2B-2.

If UE is configured for transmission on single-antenna port, the requirements in subclause 6.3.4 apply.

6.3.4D ON/OFF time mask for ProSe

For ProSe Direct Discovery and ProSe Direct Communications, additional requirements on ON/OFF time masks for ProSe physical channels and signals are specified in this clause.

6.3.4D.1 General time mask for ProSe

The General ON/OFF time mask defines the observation period between the Transmit OFF and ON power and between Transmit ON and OFF power for PSDCH, PSCCH, and PSSCH transmissions in a subframe wherein the last symbol is punctured to create a guard period.

There are no additional requirements on UE transmit power beyond that which is required in subclause 6.2.2 and subclause 6.6.2.3.

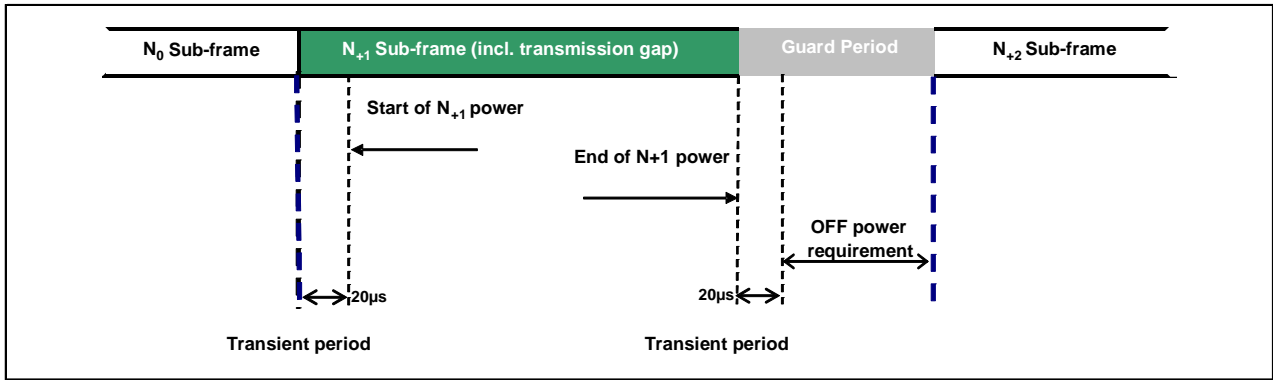

Figure 6.3.4D.1-1: PSDCH/PSCCH/PSSCH time mask

6.3.4D.2 PSSS/SSSS time mask

The PSSS time mask / SSSS time mask defines the observation period between the Transmit OFF and ON power and between Transmit ON and OFF power for PSSS/SSSS transmissions in a subframe when not multiplexed with PSBCH in that subframe.

There are no additional requirements on UE transmit power beyond that which is required in subclause 6.2.2 and subclause 6.6.2.3.

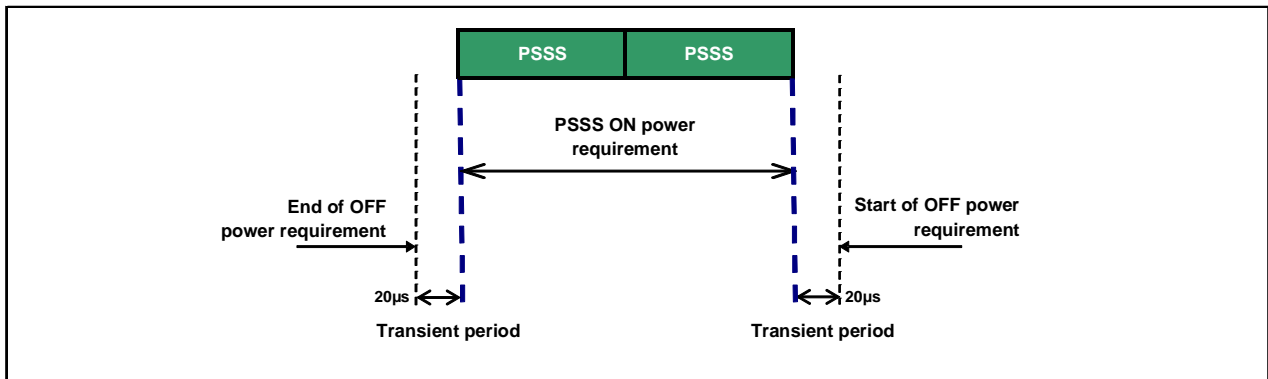

Figure 6.3.4D.2-1: PSSS time mask for normal CP transmission (when not time-multiplexed with PSBCH)

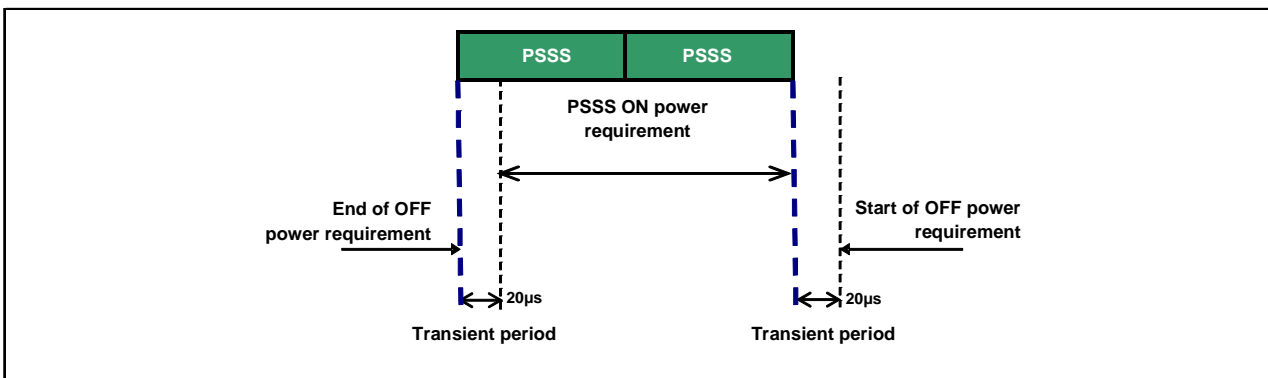

Figure 6.3.4D.2-2: PSSS time mask for extended CP transmission (when not time-multiplexed with PSBCH)

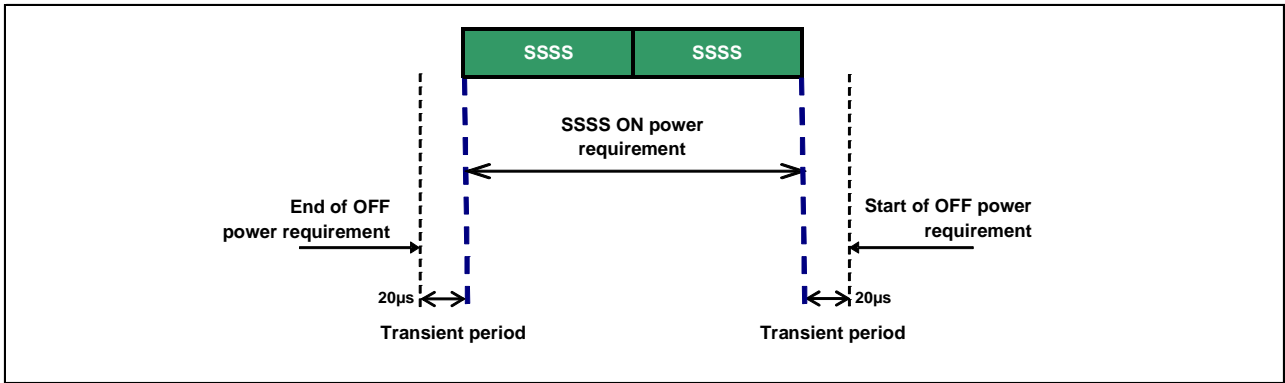

Figure 6.3.4D.2-3: SSSS time mask (when not time-multiplexed with PSBCH)

6.3.4D.3 PSSS / SSSS / PSBCH time mask

The PSSS/SSSS/PSBCH time mask defines the observation period between SSSS and adjacent PSSS/PSBCH symbols in a subframe, with last symbol punctured to create a guard period.

There are no additional requirements on UE transmit power beyond that which is required in subclause 6.2.2 and subclause 6.6.2.3.

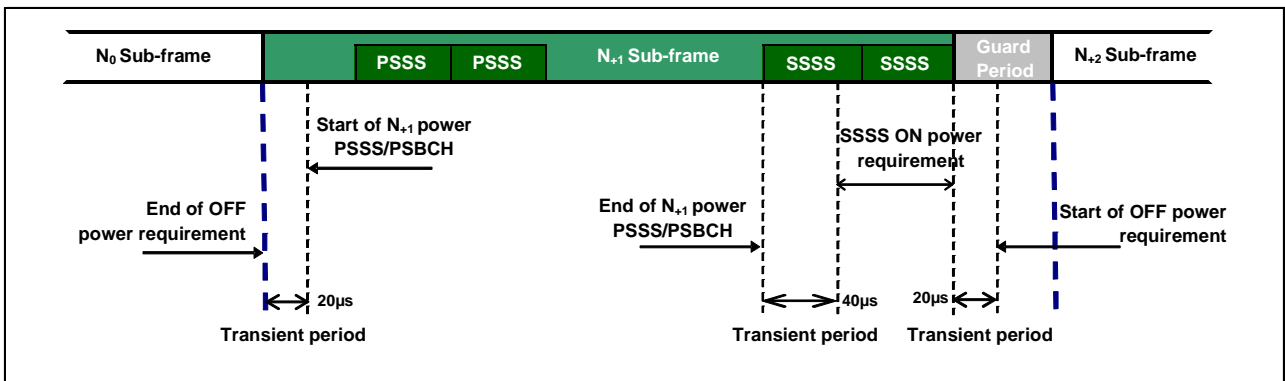

Figure 6.3.4D.3-1: PSSS/SSSS/PSBCH time mask for normal CP transmission

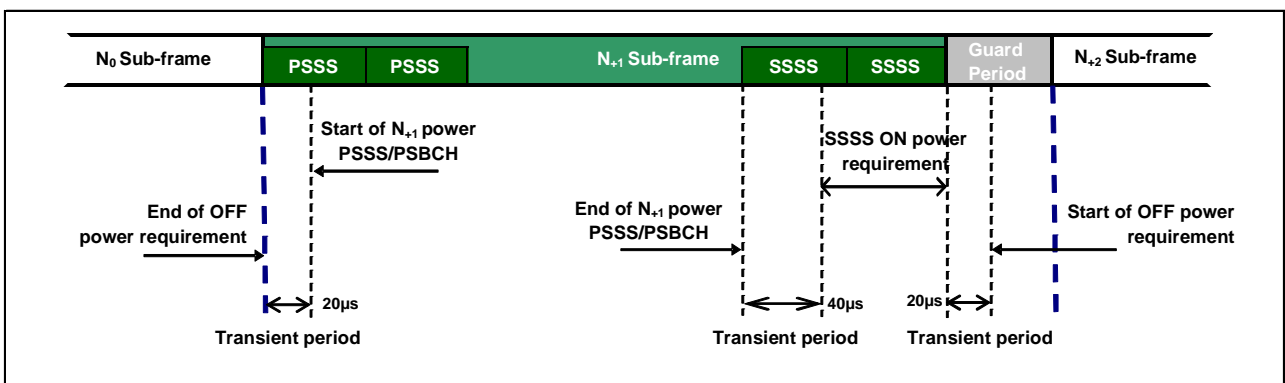

Figure 6.3.4D.3-2: PSSS/SSSS/PSBCH time mask for extended CP transmission

6.3.4D.4 PSSCH / SRS time mask

The PSSCH/SRS time mask defines the observation period between sounding reference symbol (SRS) and an adjacent PSSCH symbol and subsequent sub-frame.

There are no additional requirements on UE transmit power beyond that which is required in subclause 6.2.2 and subclause 6.6.2.3.

The PSSCH/SRS time mask shall follow the PUSCH/PUCCH/SRS time mask as specified in subclause 6.3.4.4.

6.3.5 Power Control

6.3.5.1 Absolute power tolerance

Absolute power tolerance is the ability of the UE transmitter to set its initial output power to a specific value for the first sub-frame at the start of a contiguous transmission or non-contiguous transmission with a transmission gap larger than 20ms. This tolerance includes the channel estimation error (the absolute RSRP accuracy requirement specified in subclause 9.1 of TS 36.133)

In the case of a PRACH transmission, the absolute tolerance is specified for the first preamble. The absolute power tolerance includes the channel estimation error (the absolute RSRP accuracy requirement specified in subclause 9.1 of TS 36.133).

6.3.5.1.1 Minimum requirements

The minimum requirement for absolute power tolerance is given in Table 6.3.5.1.1-1 over the power range bounded by the Maximum output power as defined in subclause 6.2.2 and the Minimum output power as defined in subclause 6.3.2.

For operating bands under Note 2 in Table 6.2.2-1, the absolute power tolerance as specified in Table 6.3.5.1.1-1 is relaxed by reducing the lower limit by 1.5 dB when the transmission bandwidth is confined within F_{UL_low} and $F_{UL_low} + 4$ MHz or $F_{UL_high} - 4$ MHz and F_{UL_high} .

Table 6.3.5.1.1-1: Absolute power tolerance

Conditions	Tolerance
Normal	± 9.0 dB
Extreme	± 12.0 dB

6.3.5.2 Relative Power tolerance

The relative power tolerance is the ability of the UE transmitter to set its output power in a target sub-frame relatively to the power of the most recently transmitted reference sub-frame if the transmission gap between these sub-frames is ≤ 20 ms.

For PRACH transmission, the relative tolerance is the ability of the UE transmitter to set its output power relatively to the power of the most recently transmitted preamble. The measurement period for the PRACH preamble is specified in Table 6.3.4.2-1.

6.3.5.2.1 Minimum requirements

The requirements specified in Table 6.3.5.2.1-1 apply when the power of the target and reference sub-frames are within the power range bounded by the Minimum output power as defined in subclause 6.3.2 and the measured PUMAX as defined in subclause 6.2.5 (i.e, the actual power as would be measured assuming no measurement error). This power shall be within the power limits specified in subclause 6.2.5.

To account for RF Power amplifier mode changes 2 exceptions are allowed for each of two test patterns. The test patterns are a monotonically increasing power sweep and a monotonically decreasing power sweep over a range bounded by the requirements of minimum power and maximum power specified in subclauses 6.3.2 and 6.2.2. For these exceptions the power tolerance limit is a maximum of ± 6.0 dB in Table 6.3.5.2.1-1

Table 6.3.5.2.1-1 Relative power tolerance for transmission (normal conditions)

Power step ΔP (Up or down) [dB]	All combinations of PUSCH and PUCCH transitions [dB]	All combinations of PUSCH/PUCCH and SRS transitions between sub- frames [dB]	PRACH [dB]
$\Delta P < 2$	± 2.5 (Note 3)	± 3.0	± 2.5
$2 \leq \Delta P < 3$	± 3.0	± 4.0	± 3.0
$3 \leq \Delta P < 4$	± 3.5	± 5.0	± 3.5
$4 \leq \Delta P \leq 10$	± 4.0	± 6.0	± 4.0
$10 \leq \Delta P < 15$	± 5.0	± 8.0	± 5.0
$15 \leq \Delta P$	± 6.0	± 9.0	± 6.0
NOTE 1: For extreme conditions an additional ± 2.0 dB relaxation is allowed NOTE 2: For operating bands under Note 2 in Table 6.2.2-1, the relative power tolerance is relaxed by increasing the upper limit by 1.5 dB if the transmission bandwidth of the reference sub-frames is confined within F_{UL_low} and $F_{UL_low} + 4$ MHz or $F_{UL_high} - 4$ MHz and F_{UL_high} and the target sub-frame is not confined within any one of these frequency ranges; if the transmission bandwidth of the target sub-frame is confined within F_{UL_low} and $F_{UL_low} + 4$ MHz or $F_{UL_high} - 4$ MHz and F_{UL_high} and the reference sub-frame is not confined within any one of these frequency ranges, then the tolerance is relaxed by reducing the lower limit by 1.5 dB. NOTE 3: For PUSCH to PUSCH transitions with the allocated resource blocks fixed in frequency and no transmission gaps other than those generated by downlink subframes, DwPTS fields or Guard Periods for TDD: for a power step $\Delta P \leq 1$ dB, the relative power tolerance for transmission is ± 1.0 dB.			

The power step (ΔP) is defined as the difference in the calculated setting of the UE Transmit power between the target and reference sub-frames with the power setting according to subclause 5.1 of [TS 36.213]. The error is the difference between ΔP and the power change measured at the UE antenna port with the power of the cell-specific reference signals kept constant. The error shall be less than the relative power tolerance specified in Table 6.3.5.2.1-1.

For sub-frames not containing an SRS symbol, the power change is defined as the relative power difference between the mean power of the original reference sub-frame and the mean power of the target subframe not including transient durations. The mean power of successive sub-frames shall be calculated according to Figure 6.3.4.3-1 and Figure 6.3.4.1-1 if there is a transmission gap between the reference and target sub-frames.

If at least one of the sub-frames contains an SRS symbol, the power change is defined as the relative power difference between the mean power of the last transmission within the reference sub-frame and the mean power of the first transmission within the target sub-frame not including transient durations. A transmission is defined as PUSCH, PUCCH or an SRS symbol. The mean power of the reference and target sub-frames shall be calculated according to Figures 6.3.4.1-1, 6.3.4.2-1, 6.3.4.4-1, 6.3.4.4-2 and 6.3.4.4-3 for these cases.

6.3.5.3 Aggregate power control tolerance

Aggregate power control tolerance is the ability of a UE to maintain its power in non-contiguous transmission within 21 ms in response to 0 dB TPC commands with respect to the first UE transmission, when the power control parameters specified in TS 36.213 are constant.

6.3.5.3.1 Minimum requirement

The UE shall meet the requirements specified in Table 6.3.5.3.1-1 for aggregate power control over the power range bounded by the minimum output power as defined in subclause 6.3.2 and the maximum output power as defined in subclause 6.2.2.

Table 6.3.5.3.1-1: Aggregate power control tolerance

TPC command	UL channel	Aggregate power tolerance within 21 ms
0 dB	PUCCH	± 2.5 dB
0 dB	PUSCH	± 3.5 dB
NOTE: The UE transmission gap is 4 ms. TPC command is transmitted via PDCCH 4 subframes preceding each PUCCH/PUSCH transmission.		

6.3.5A Power control for CA

The requirements apply for one single PUCCH, PUSCH or SRS transmission of contiguous PRB allocation per component carrier with power setting in accordance with Clause 5.1 of [6].

6.3.5A.1 Absolute power tolerance

The absolute power tolerance is the ability of the UE transmitter to set its initial output power to a specific value for the first sub-frame at the start of a contiguous transmission or non-contiguous transmission with a transmission gap on each active component carriers larger than 20ms. The requirement can be tested by time aligning any transmission gaps on the component carriers.

6.3.5A.1.1 Minimum requirements

For inter-band carrier aggregation with uplink assigned to two E-UTRA bands, the absolute power control tolerance is specified on each component carrier exceed the minimum output power as defined in subclause 6.3.2A and the total power is limited by maximum output power as defined in subclause 6.2.2A. The requirements defined in Table 6.3.5.1.1-1 shall apply on each component carrier with both component carriers active. The requirements can be tested by time aligning any transmission gaps on both the component carriers.

For intra-band contiguous carrier aggregation bandwidth class C and intra-band non-contiguous carrier aggregation the absolute power control tolerance per component carrier is given in Table 6.3.5.1.1-1.

6.3.5A.2 Relative power tolerance

6.3.5A.2.1 Minimum requirements

For inter-band carrier aggregation with uplink assigned to two E-UTRA bands, the relative power tolerance is specified when the power of the target and reference sub-frames on each component carrier exceed the minimum output power as defined in subclause 6.3.2A and the total power is limited by P_{UMAX} as defined in subclause 6.2.5A. The requirements shall apply on each component carrier with both component carriers active. The UE transmitter shall have the capability of changing the output power independently on all component carriers in the uplink and:

- a) the requirements for all combinations of PUSCH and PUCCH transitions per component carrier is given in Table 6.3.5.2.1-1.
- b) for SRS the requirements for combinations of PUSCH/PUCCH and SRS transitions between subframes given in Table 6.3.5.2.1-1 apply per component carrier when the target and reference subframes are configured for either simultaneous SRS or simultaneous PUSCH.
- c) for RACH the requirements apply for the primary cell and are given in Table 6.3.5.2.1-1.

For intra-band contiguous carrier aggregation bandwidth class B and C and intra-band non-contiguous carrier aggregation, the requirements apply when the power of the target and reference sub-frames on each component carrier exceed -20 dBm and the total power is limited by P_{UMAX} as defined in subclause 6.2.5A. For the purpose of these requirements, the power in each component carrier is specified over only the transmitted resource blocks.

The UE shall meet the following requirements for transmission on both assigned component carriers when the average transmit power per PRB is aligned across both assigned carriers in the reference sub-frame:

- a) for all possible combinations of PUSCH and PUCCH transitions per component carrier, the corresponding requirements given in Table 6.3.5.2.1-1;

- b) for SRS transitions on each component carrier, the requirements for combinations of PUSCH/PUCCH and SRS transitions given in Table 6.3.5.2.1-1 with simultaneous SRS of constant SRS bandwidth allocated in the target and reference subframes;
- c) for RACH on the primary component carrier, the requirements given in Table 6.3.5.2.1-1 for PRACH.

For a) and b) above, the power step ΔP between the reference and target subframes shall be set by a TPC command and/or an uplink scheduling grant transmitted by means of an appropriate DCI Format.

For a), b) and c) above, two exceptions are allowed for each component carrier for a power per carrier ranging from -20 dBm to $P_{UMAX,c}$ as defined in subclause 6.2.5. For these exceptions the power tolerance limit is ± 6.0 dB in Table 6.3.5.2.1-1.

6.3.5A.3 Aggregate power control tolerance

Aggregate power control tolerance is the ability of a UE to maintain its power in non-contiguous transmission within 21 ms in response to 0 dB TPC commands with respect to the first UE transmission, when the power control parameters specified in [6] are constant on all active component carriers.

6.3.5A.3.1 Minimum requirements

For inter-band carrier aggregation with uplink assigned to two E-UTRA bands, the aggregate power tolerance is specified on each component carrier exceed the minimum output power as defined in subclause 6.3.2A and the total power is limited by maximum output power as defined in subclause 6.2.2A. The requirements defined in Table 6.3.5.3.1-1 shall apply on each component carrier with both component carriers active. The requirements can be tested by time aligning any transmission gaps on both the component carriers.

For intra-band contiguous carrier aggregation bandwidth class C and intra-band non-contiguous carrier aggregation, the aggregate power tolerance per component carrier is given in Table 6.3.5.3.1-1 with either simultaneous PUSCH or simultaneous PUCCH-PUSCH (if supported by the UE) configured. The average power per PRB shall be aligned across both assigned carriers before the start of the test. The requirement can be tested with the transmission gaps time aligned between component carriers.

6.3.5B Power control for UL-MIMO

For UE supporting UL-MIMO, the power control tolerance applies to the sum of output power at each transmit antenna connector.

The power control requirements specified in subclause 6.3.5 apply to UE with two transmit antenna connectors in closed-loop spatial multiplexing scheme. The requirements shall be met with UL-MIMO configurations specified in Table 6.2.2B-2, wherein

- The Maximum output power requirements for UL-MIMO are specified in subclause 6.2.2B
- The Minimum output power requirements for UL-MIMO are specified in subclause 6.3.2B
- The requirements for configured transmitted power for UL-MIMO are specified in subclause 6.2.5B.

If UE is configured for transmission on single-antenna port, the requirements in subclause 6.3.5 apply.

6.3.5D Power Control for ProSe

6.3.5D.1 Absolute power tolerance

For ProSe transmissions, the absolute power tolerance requirements specified in subclause 6.3.5.1 shall apply for each ProSe transmission.

6.4 Void

6.5 Transmit signal quality

6.5.1 Frequency error

The UE modulated carrier frequency shall be accurate to within ± 0.1 PPM observed over a period of one time slot (0.5 ms) compared to the carrier frequency received from the E-UTRA Node B

6.5.1A Frequency error for CA

For inter-band carrier aggregation with uplink assigned to two E-UTRA bands, the frequency error requirements defined in subclause 6.5.1 shall apply on each component carrier with both component carriers active.

For intra-band contiguous carrier aggregation the UE modulated carrier frequencies per band shall be accurate to within ± 0.1 PPM observed over a period of one timeslot compared to the carrier frequency of primary component carrier received from the E-UTRA in the corresponding band.

For intra-band non-contiguous carrier aggregation the requirements in Section 6.5.1 applies per component carrier.

6.5.1B Frequency error for UL-MIMO

For UE(s) supporting UL-MIMO, the UE modulated carrier frequency at each transmit antenna connector shall be accurate to within ± 0.1 PPM observed over a period of one time slot (0.5 ms) compared to the carrier frequency received from the E-UTRA Node B.

6.5.1D Frequency error for ProSe

The UE modulated carrier frequency for ProSe sidelink transmissions shall be accurate to within ± 0.1 PPM observed over a period of one time slot (0.5 ms) compared to the carrier frequency received from the synchronization source. The synchronization source can be E-UTRA Node B or a ProSe UE transmitting sidelink synchronization signals.

6.5.2 Transmit modulation quality

Transmit modulation quality defines the modulation quality for expected in-channel RF transmissions from the UE. The transmit modulation quality is specified in terms of:

- Error Vector Magnitude (EVM) for the allocated resource blocks (RBs)
- EVM equalizer spectrum flatness derived from the equalizer coefficients generated by the EVM measurement process
- Carrier leakage
- In-band emissions for the non-allocated RB

All the parameters defined in subclause 6.5.2 are defined using the measurement methodology specified in Annex F.

6.5.2.1 Error Vector Magnitude

The Error Vector Magnitude is a measure of the difference between the reference waveform and the measured waveform. This difference is called the error vector. Before calculating the EVM the measured waveform is corrected by the sample timing offset and RF frequency offset. Then the carrier leakage shall be removed from the measured waveform before calculating the EVM.

The measured waveform is further modified by selecting the absolute phase and absolute amplitude of the Tx chain. The EVM result is defined after the front-end IDFT as the square root of the ratio of the mean error vector power to the mean reference power expressed as a %.

The basic EVM measurement interval in the time domain is one preamble sequence for the PRACH and is one slot for the PUCCH and PUSCH in the time domain.. When the PUSCH or PUCCH transmission slot is shortened due to multiplexing with SRS, the EVM measurement interval is reduced by one symbol, accordingly. The PUSCH or PUCCH EVM measurement interval is also reduced when the mean power, modulation or allocation between slots is expected to change. In the case of PUSCH transmission, the measurement interval is reduced by a time interval equal to the sum of 5 μ s and the applicable exclusion period defined in subclause 6.3.4, adjacent to the boundary where the power change is expected to occur. The PUSCH exclusion period is applied to the signal obtained after the front-end IDFT. In the case of PUCCH transmission with power change, the PUCCH EVM measurement interval is reduced by one symbol adjacent to the boundary where the power change is expected to occur.

6.5.2.1.1 Minimum requirement

The RMS average of the basic EVM measurements for 10 sub-frames excluding any transient period for the average EVM case, and 60 sub-frames excluding any transient period for the reference signal EVM case, for the different modulations schemes shall not exceed the values specified in Table 6.5.2.1.1-1 for the parameters defined in Table 6.5.2.1.1-2. For EVM evaluation purposes, [all PRACH preamble formats 0-4 and] all PUCCH formats 1, 1a, 1b, 2, 2a and 2b are considered to have the same EVM requirement as QPSK modulated.

Table 6.5.2.1.1-1: Minimum requirements for Error Vector Magnitude

Parameter	Unit	Average EVM Level	Reference Signal EVM Level
QPSK or BPSK	%	17.5	17.5
16QAM	%	12.5	12.5

Table 6.5.2.1.1-2: Parameters for Error Vector Magnitude

Parameter	Unit	Level
UE Output Power	dBm	≥ -40
Operating conditions		Normal conditions

6.5.2.2 Carrier leakage

Carrier leakage is an additive sinusoid waveform that has the same frequency as a modulated waveform carrier frequency. The measurement interval is one slot in the time domain.

6.5.2.2.1 Minimum requirements

The relative carrier leakage power is a power ratio of the additive sinusoid waveform and the modulated waveform. The relative carrier leakage power shall not exceed the values specified in Table 6.5.2.2.1-1.

Table 6.5.2.2.1-1: Minimum requirements for relative carrier leakage power

Parameters	Relative limit (dBc)	Applicable frequencies
Output power >10 dBm	-28	Carrier center frequency < 1 GHz
	-25	Carrier center frequency ≥ 1 GHz
0 dBm \leq Output power ≤ 10 dBm	-25	
-30 dBm \leq Output power ≤ 0 dBm	-20	
-40 dBm \leq Output power < -30 dBm	-10	

6.5.2.3 In-band emissions

The in-band emission is defined as the average across 12 sub-carrier and as a function of the RB offset from the edge of the allocated UL transmission bandwidth. The in-band emission is measured as the ratio of the UE output power in a non-allocated RB to the UE output power in an allocated RB.

The basic in-band emissions measurement interval is defined over one slot in the time domain. When the PUSCH or PUCCH transmission slot is shortened due to multiplexing with SRS, the in-band emissions measurement interval is reduced by one SC-FDMA symbol, accordingly.

6.5.2.3.1 Minimum requirements

The relative in-band emission shall not exceed the values specified in Table 6.5.2.3.1-1.

Table 6.5.2.3.1-1: Minimum requirements for in-band emissions

Parameter description	Unit	Limit (Note 1)		Applicable Frequencies
General	dB	$\max \left\{ -25 - 10 \cdot \log_{10} (N_{RB} / L_{CRB}), \right.$ $20 \cdot \log_{10} EVM - 3 - 5 \cdot (\Delta_{RB} - 1) / L_{CRB},$ $\left. -57 \text{ dBm} / 180 \text{ kHz} - P_{RB} \right\}$		Any non-allocated (Note 2)
IQ Image	dB	-28	Image frequencies when carrier center frequency < 1 GHz and Output power > 10 dBm	Image frequencies (Notes 2, 3)
		-25	Image frequencies when carrier center frequency < 1 GHz and Output power ≤ 10 dBm	
		-25	Image frequencies when carrier center frequency ≥ 1 GHz	
Carrier leakage	dBc	-28	Output power > 10 dBm and carrier center frequency < 1 GHz	Carrier frequency (Notes 4, 5)
		-25	Output power > 10 dBm and carrier center frequency ≥ 1 GHz	
		-25	0 dBm ≤ Output power ≤ 10 dBm	
		-20	-30 dBm ≤ Output power ≤ 0 dBm	
		-10	-40 dBm ≤ Output power < -30 dBm	
<p>NOTE 1: An in-band emissions combined limit is evaluated in each non-allocated RB. For each such RB, the minimum requirement is calculated as the higher of $P_{RB} - 30$ dB and the power sum of all limit values (General, IQ Image or Carrier leakage) that apply. P_{RB} is defined in Note 10.</p> <p>NOTE 2: The measurement bandwidth is 1 RB and the limit is expressed as a ratio of measured power in one non-allocated RB to the measured average power per allocated RB, where the averaging is done across all allocated RBs.</p> <p>NOTE 3: The applicable frequencies for this limit are those that are enclosed in the reflection of the allocated bandwidth, based on symmetry with respect to the centre carrier frequency, but excluding any allocated RBs.</p> <p>NOTE 4: The measurement bandwidth is 1 RB and the limit is expressed as a ratio of measured power in one non-allocated RB to the measured total power in all allocated RBs.</p> <p>NOTE 5: The applicable frequencies for this limit are those that are enclosed in the RBs containing the DC frequency if N_{RB} is odd, or in the two RBs immediately adjacent to the DC frequency if N_{RB} is even, but excluding any allocated RB.</p> <p>NOTE 6: L_{CRB} is the Transmission Bandwidth (see Figure 5.6-1).</p> <p>NOTE 7: N_{RB} is the Transmission Bandwidth Configuration (see Figure 5.6-1).</p> <p>NOTE 8: EVM is the limit specified in Table 6.5.2.1.1-1 for the modulation format used in the allocated RBs.</p> <p>NOTE 9: Δ_{RB} is the starting frequency offset between the allocated RB and the measured non-allocated RB (e.g. $\Delta_{RB} = 1$ or $\Delta_{RB} = -1$ for the first adjacent RB outside of the allocated bandwidth).</p> <p>NOTE 10: P_{RB} is the transmitted power per 180 kHz in allocated RBs, measured in dBm.</p>				

6.5.2.4 EVM equalizer spectrum flatness

The zero-forcing equalizer correction applied in the EVM measurement process (as described in Annex F) must meet a spectral flatness requirement for the EVM measurement to be valid. The EVM equalizer spectrum flatness is defined in terms of the maximum peak-to-peak ripple of the equalizer coefficients (dB) across the allocated uplink block. The basic measurement interval is the same as for EVM.

6.5.2.4.1 Minimum requirements

The peak-to-peak variation of the EVM equalizer coefficients contained within the frequency range of the uplink allocation shall not exceed the maximum ripple specified in Table 6.5.2.4.1-1 for normal conditions. For uplink allocations contained within both Range 1 and Range 2, the coefficients evaluated within each of these frequency ranges shall meet the corresponding ripple requirement and the following additional requirement: the relative difference between the maximum coefficient in Range 1 and the minimum coefficient in Range 2 must not be larger than 5 dB,

and the relative difference between the maximum coefficient in Range 2 and the minimum coefficient in Range 1 must not be larger than 7 dB (see Figure 6.5.2.4.1-1).

The EVM equalizer spectral flatness shall not exceed the values specified in Table 6.5.2.4.1-2 for extreme conditions. For uplink allocations contained within both Range 1 and Range 2, the coefficients evaluated within each of these frequency ranges shall meet the corresponding ripple requirement and the following additional requirement: the relative difference between the maximum coefficient in Range 1 and the minimum coefficient in Range 2 must not be larger than 6 dB, and the relative difference between the maximum coefficient in Range 2 and the minimum coefficient in Range 1 must not be larger than 10 dB (see Figure 6.5.2.4.1-1).

Table 6.5.2.4.1-1: Minimum requirements for EVM equalizer spectrum flatness (normal conditions)

Frequency range	Maximum ripple [dB]
$F_{UL_Meas} - F_{UL_Low} \geq 3$ MHz and $F_{UL_High} - F_{UL_Meas} \geq 3$ MHz (Range 1)	4 (p-p)
$F_{UL_Meas} - F_{UL_Low} < 3$ MHz or $F_{UL_High} - F_{UL_Meas} < 3$ MHz (Range 2)	8 (p-p)
NOTE 1: F_{UL_Meas} refers to the sub-carrier frequency for which the equalizer coefficient is evaluated	
NOTE 2: F_{UL_Low} and F_{UL_High} refer to each E-UTRA frequency band specified in Table 5.5-1	

Table 6.5.2.4.1-2: Minimum requirements for EVM equalizer spectrum flatness (extreme conditions)

Frequency range	Maximum Ripple [dB]
$F_{UL_Meas} - F_{UL_Low} \geq 5$ MHz and $F_{UL_High} - F_{UL_Meas} \geq 5$ MHz (Range 1)	4 (p-p)
$F_{UL_Meas} - F_{UL_Low} < 5$ MHz or $F_{UL_High} - F_{UL_Meas} < 5$ MHz (Range 2)	12 (p-p)
NOTE 1: F_{UL_Meas} refers to the sub-carrier frequency for which the equalizer coefficient is evaluated	
NOTE 2: F_{UL_Low} and F_{UL_High} refer to each E-UTRA frequency band specified in Table 5.5-1	

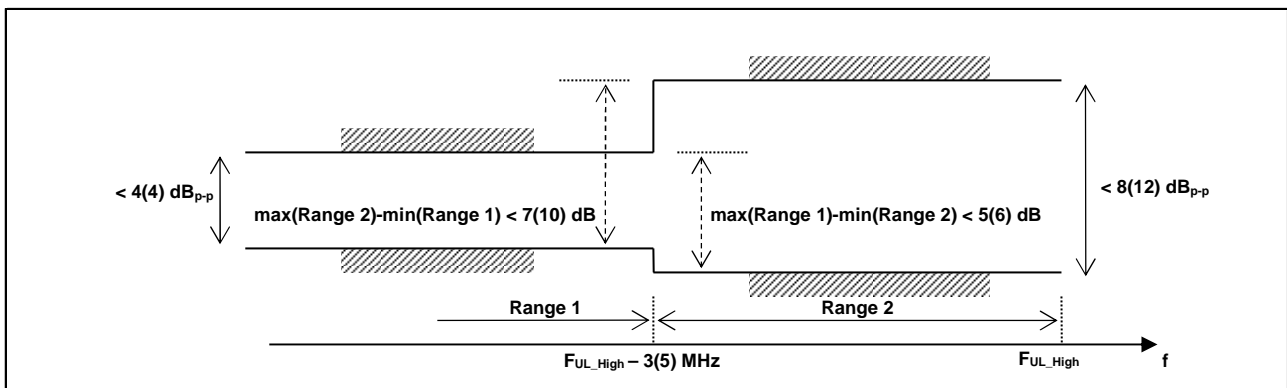

Figure 6.5.2.4.1-1: The limits for EVM equalizer spectral flatness with the maximum allowed variation of the coefficients indicated (the ETC minimum requirement within brackets).

6.5.2A Transmit modulation quality for CA

For inter-band carrier aggregation with uplink assigned to two E-UTRA bands, the requirements shall apply on each component carrier as defined in clause 6.5.2 with both component carriers active.

The requirements in this clause apply with PCC and SCC in the UL configured and activated: PCC with PRB allocation and SCC without PRB allocation and without CSI reporting and SRS configured.

6.5.2A.1 Error Vector Magnitude

For the intra-band contiguous and non-contiguous carrier aggregation, the Error Vector Magnitude requirement should be defined for each component carrier. Requirements only apply with PRB allocation in one of the component carriers. Similar transmitter impairment removal procedures are applied for CA waveform before EVM calculation as is specified for non-CA waveform in sub-section 6.5.2.1.

When a single component carrier is configured Table 6.5.2.1.1-1 apply.

The EVM requirements are according to Table 6.5.2A.1-1 if CA is configured in uplink.

Table 6.5.2A.1-1: Minimum requirements for Error Vector Magnitude

Parameter	Unit	Average EVM Level per CC	Reference Signal EVM Level
QPSK or BPSK	%	17.5	17.5
16QAM	%	12.5	12.5

6.5.2A.2 Carrier leakage for CA

Carrier leakage is an additive sinusoid waveform that is confined within the aggregated transmission bandwidth configuration. The carrier leakage requirement is defined for each component carrier and is measured on the component carrier with PRBs allocated. The measurement interval is one slot in the time domain.

6.5.2A.2.1 Minimum requirements

The relative carrier leakage power is a power ratio of the additive sinusoid waveform and the modulated waveform. The relative carrier leakage power shall not exceed the values specified in Table 6.5.2A.2.1-1.

Table 6.5.2A.2.1-1: Minimum requirements for Relative Carrier Leakage Power

Parameters	Relative Limit (dBc)
Output power >0 dBm	-25
-30 dBm ≤ Output power ≤ 0 dBm	-20
-40 dBm ≤ Output power < -30 dBm	-10

6.5.2A.3 In-band emissions

6.5.2A.3.1 Minimum requirement for CA

For intra-band contiguous carrier aggregation bandwidth class C, the requirements in Table 6.5.2A.3.1-1 and 6.5.2A.3.1-2 apply within the aggregated transmission bandwidth configuration with both component carrier (s) active and one single contiguous PRB allocation of bandwidth L_{CRB} at the edge of the aggregated transmission bandwidth configuration.

The inband emission is defined as the interference falling into the non allocated resource blocks for all component carriers. The measurement method for the inband emissions in the component carrier with PRB allocation is specified in annex F. For a non allocated component carrier a spectral measurement is specified.

For intra-band non-contiguous carrier aggregation the requirements for in-band emissions should be defined for each component carrier. Requirements only apply with PRB allocation in one of the component carriers according to Table 6.5.2.3.1.

Table 6.5.2A.3.1-1: Minimum requirements for in-band emissions (allocated component carrier)

Parameter	Unit	Limit	Applicable Frequencies
General	dB	$\max \left\{ -25 - 10 \cdot \log_{10} (N_{RB} / L_{CRB}), \right.$ $20 \cdot \log_{10} EVM - 3 - 5 \cdot (\Delta_{RB} - 1) / L_{CRB},$ $\left. -57 \text{ dBm} / 180 \text{ kHz} - P_{RB} \right\}$	Any non-allocated (Note 2)
IQ Image	dB	-25	Exception for IQ image (Note 3)
Carrier leakage	dBc	-25	Exception for Carrier frequency (Note 4)
		-20	
		-10	
<p>NOTE 1: An in-band emissions combined limit is evaluated in each non-allocated RB. For each such RB, the minimum requirement is calculated as the higher of $P_{RB} - 30$ dB and the power sum of all limit values (General, IQ Image or Carrier leakage) that apply. P_{RB} is defined in Note 9. The limit is evaluated in each non-allocated RB.</p> <p>NOTE 2: The measurement bandwidth is 1 RB and the limit is expressed as a ratio of measured power in one non-allocated RB to the measured average power per allocated RB, where the averaging is done across all allocated RBs</p> <p>NOTE 3: Exceptions to the general limit are allowed for up to $L_{CRBs} + 1$ RBs within a contiguous width of $L_{CRBs} + 1$ non-allocated RBs. The measurement bandwidth is 1 RB.</p> <p>NOTE 4: Exceptions to the general limit are allowed for up to two contiguous non-allocated RBs. The measurement bandwidth is 1 RB and the limit is expressed as a ratio of measured power in the non-allocated RB to the measured total power in all allocated RBs.</p> <p>NOTE 5: L_{CRB} is the Transmission Bandwidth (see Figure 5.6-1) not exceeding $\lfloor N_{RB} / 2 - 1 \rfloor$</p> <p>NOTE 6: N_{RB} is the Transmission Bandwidth Configuration (see Figure 5.6-1) of the component carrier with RBs allocated.</p> <p>NOTE 7: EVM is the limit specified in Table 6.5.2.1.1-1 for the modulation format used in the allocated RBs.</p> <p>NOTE 8: Δ_{RB} is the starting frequency offset between the allocated RB and the measured non-allocated RB (e.g. $\Delta_{RB} = 1$ or $\Delta_{RB} = -1$ for the first adjacent RB outside of the allocated bandwidth).</p> <p>NOTE 9: P_{RB} is the transmitted power per 180 kHz in allocated RBs, measured in dBm.</p>			

Table 6.5.2A.3.1-2: Minimum requirements for in-band emissions (not allocated component carrier)

Parameter	Unit	Meas BW Note 1	Limit	remark	Applicable Frequencies	
General	dB	BW of 1 RB (180KHz rectangular)	$\max \left\{ -25 - 10 \cdot \log_{10} (N_{RB} / L_{CRB}), \right.$ $20 \cdot \log_{10} EVM - 3 - 5 \cdot (\Delta_{RB} - 1) / L_{CRB},$ $\left. -57 \text{ dBm} / 180 \text{ kHz} - P_{RB} \right\}$	The reference value is the average power per allocated RB in the allocated component carrier	Any RB in the non allocated component carrier. The frequency raster of the RBs is derived when this component carrier is allocated with RBs	
IQ Image	dB	BW of 1 RB (180KHz rectangular)	-25 Note 2	The reference value is the average power per allocated RB in the allocated component carrier	The frequencies of the L_{CRB} contiguous non-allocated RBs are unknown. The frequency raster of the RBs is derived when this component carrier is allocated with RBs	
Carrier leakage	dBc	BW of 1 RB (180KHz rectangular)	Note 3		The reference value is the total power of the allocated RBs in the allocated component carrier	The frequencies of the up to 2 non-allocated RBs are unknown. The frequency raster of the RBs is derived when this component carrier is allocated with RBs
			-25	Output power > 0 dBm		
			-20	-30 dBm ≤ Output power ≤ 0 dBm		
			-10	-40 dBm ≤ Output power < -30 dBm		
NOTE 1: Resolution BWs smaller than the measurement BW may be integrated to achieve the measurement bandwidth.						
NOTE 2: Exceptions to the general limit is are allowed for up to $L_{CRB} + 1$ RBs within a contiguous width of $L_{CRB} + 1$ non-allocated RBs.						
NOTE 3: Two Exceptions to the general limit are allowed for up to two contiguous non-allocated RBs						
NOTE 4: Notes 1, 5, 6, 7, 8, 9 from Table 6.5.2A.3.1-1 apply for Table 6.5.2A.3.1-2 as well.						
NOTE 5: Δ_{RB} for measured non-allocated RB in the non allocated component carrier may take non-integer values when the carrier spacing between the CCs is not a multiple of RB.						

6.5.2B Transmit modulation quality for UL-MIMO

For UE supporting UL-MIMO, the transmit modulation quality requirements are specified at each transmit antenna connector.

If UE is configured for transmission on single-antenna port, the requirements in subclause 6.5.2 apply.

The transmit modulation quality is specified in terms of:

- Error Vector Magnitude (EVM) for the allocated resource blocks (RBs)
- EVM equalizer spectrum flatness derived from the equalizer coefficients generated by the EVM measurement process
- Carrier leakage (caused by IQ offset)
- In-band emissions for the non-allocated RB

6.5.2B.1 Error Vector Magnitude

For UE with two transmit antenna connectors in closed-loop spatial multiplexing scheme, the Error Vector Magnitude requirements specified in Table 6.5.2.1.1-1 which is defined in subclause 6.5.2.1 apply at each transmit antenna connector. The requirements shall be met with the UL-MIMO configurations specified in Table 6.2.2B-2.

6.5.2B.2 Carrier leakage

For UE with two transmit antenna connectors in closed-loop spatial multiplexing scheme, the Relative Carrier Leakage Power requirements specified in Table 6.5.2.2.1-1 which is defined in subclause 6.5.2.2 apply at each transmit antenna connector. The requirements shall be met with the UL-MIMO configurations specified in Table 6.2.2B-2.

6.5.2B.3 In-band emissions

For UE with two transmit antenna connectors in closed-loop spatial multiplexing scheme, the In-band Emission requirements specified in Table 6.5.2.3.1-1 which is defined in subclause 6.5.2.3 apply at each transmit antenna connector. The requirements shall be met with the uplink MIMO configurations specified in Table 6.2.2B-2.

6.5.2B.4 EVM equalizer spectrum flatness for UL-MIMO

For UE with two transmit antenna connectors in closed-loop spatial multiplexing scheme, the EVM Equalizer Spectrum Flatness requirements specified in Table 6.5.2.4.1-1 and Table 6.5.2.4.1-2 which are defined in subclause 6.5.2.4 apply at each transmit antenna connector. The requirements shall be met with the UL-MIMO configurations specified in Table 6.2.2B-2.

6.5.2D Transmit modulation quality for ProSe

The requirements in this clause apply to ProSe sidelink transmissions.

6.5.2D.1 Error Vector Magnitude

For ProSe sidelink physical channels PSDCH, PSCCH, PSSCH, and PSBCH, the Error Vector Magnitude requirements shall be as specified for PUSCH in subclause 6.5.2.1 for the corresponding modulation and transmission bandwidth. When ProSe transmissions are shortened due to transmission gap of 1 symbol at the end of the subframe, the EVM measurement interval is reduced by one symbol, accordingly.

For PSBCH the duration over which EVM is averaged shall be 24 subframes.

This requirement is not applicable for ProSe physical signals PSSS and SSSS.

6.5.2D.2 Carrier leakage

The requirements of subcaluse 6.5.2.2 shall apply for ProSe transmissions.

6.5.2D.3 In-band emissions

For ProSe sidelink physical channels PSDCH, PSCCH, PSSCH, and PSBCH, the In-band emissions requirements shall be as specified for PUSCH in subclause 6.5.2.3 for the corresponding modulation and transmission bandwidth. When ProSe transmissions are shortened due to transmission gap of 1 symbol at the end of the subframe, the In-band emissions measurement interval is reduced by one symbol, accordingly.

6.5.2D.4 EVM equalizer spectrum flatness for ProSe

The requirements of subclause 6.5.2.4 shall apply for ProSe transmissions.

6.6 Output RF spectrum emissions

The output UE transmitter spectrum consists of the three components; the emission within the occupied bandwidth (channel bandwidth), the Out Of Band (OOB) emissions and the far out spurious emission domain.

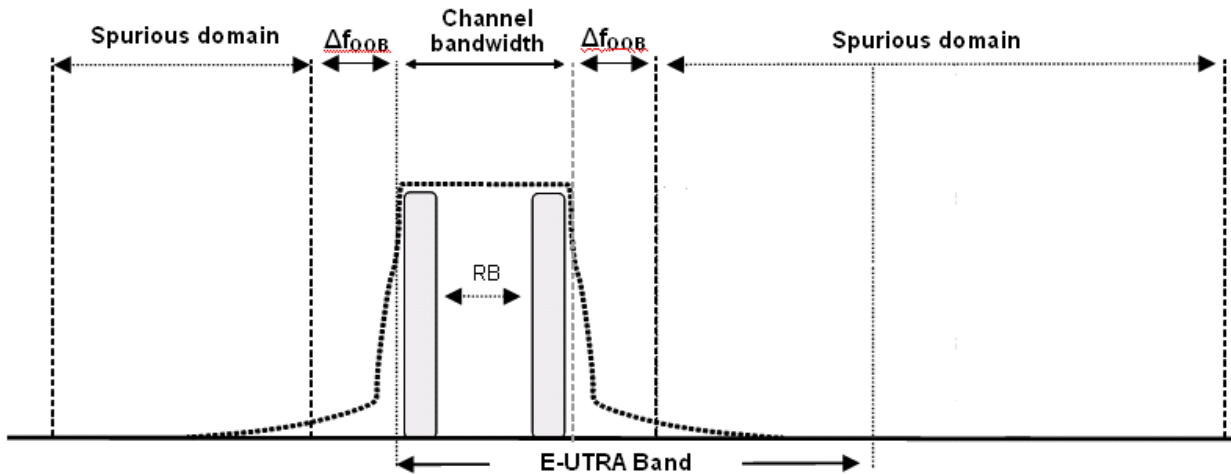

Figure 6.6-1: Transmitter RF spectrum

6.6.1 Occupied bandwidth

Occupied bandwidth is defined as the bandwidth containing 99 % of the total integrated mean power of the transmitted spectrum on the assigned channel. The occupied bandwidth for all transmission bandwidth configurations (Resources Blocks) shall be less than the channel bandwidth specified in Table 6.6.1-1

Table 6.6.1-1: Occupied channel bandwidth

	Occupied channel bandwidth / Channel bandwidth					
	1.4 MHz	3.0 MHz	5 MHz	10 MHz	15 MHz	20 MHz
Channel bandwidth (MHz)	1.4	3	5	10	15	20

6.6.1A Occupied bandwidth for CA

For inter-band carrier aggregation with uplink assigned to two E-UTRA bands the occupied bandwidth is defined per component carrier. Occupied bandwidth is the bandwidth containing 99 % of the total integrated mean power of the transmitted spectrum on assigned channel bandwidth on the component carrier. The occupied bandwidth shall be less than the channel bandwidth specified in Table 6.6.1-1.

For intra-band contiguous carrier aggregation the occupied bandwidth is a measure of the bandwidth containing 99 % of the total integrated power of the transmitted spectrum. The OBW shall be less than the aggregated channel bandwidth defined in subclause 5.6A.

For intra-band non-contiguous carrier aggregation sub-block occupied bandwidth is defined as the bandwidth containing 99 % of the total integrated mean power of the transmitted spectrum on the sub-block. In case the sub-block consist of one component carrier the occupied bandwidth of the sub-block shall be less than the channel bandwidth specified in Table 6.6.1-1.

6.6.1B Occupied bandwidth for UL-MIMO

For UE supporting UL-MIMO, the requirements for occupied bandwidth is specified at each transmit antenna connector. The occupied bandwidth is defined as the bandwidth containing 99 % of the total integrated mean power of the transmitted spectrum on the assigned channel at each transmit antenna connector.

For UE with two transmit antenna connectors in closed-loop spatial multiplexing scheme, the occupied bandwidth at each transmitter antenna shall be less than the channel bandwidth specified in Table 6.6.1B-1. The requirements shall be met with the UL-MIMO configurations specified in Table 6.2.2B-2.

Table 6.6.1B-1: Occupied channel bandwidth

	Occupied channel bandwidth / Channel bandwidth					
	1.4 MHz	3.0 MHz	5 MHz	10 MHz	15 MHz	20 MHz
Channel bandwidth (MHz)	1.4	3	5	10	15	20

If UE is configured for transmission on single-antenna port, the requirements in subclause 6.6.1 apply.

6.6.2 Out of band emission

The Out of band emissions are unwanted emissions immediately outside the assigned channel bandwidth resulting from the modulation process and non-linearity in the transmitter but excluding spurious emissions. This out of band emission limit is specified in terms of a spectrum emission mask and an Adjacent Channel Leakage power Ratio.

6.6.2.1 Spectrum emission mask

The spectrum emission mask of the UE applies to frequencies (Δf_{OoB}) starting from the \pm edge of the assigned E-UTRA channel bandwidth. For frequencies greater than (Δf_{OoB}) as specified in Table 6.6.2.1.1-1 the spurious requirements in subclause 6.6.3 are applicable.

6.6.2.1.1 Minimum requirement

The power of any UE emission shall not exceed the levels specified in Table 6.6.2.1.1-1 for the specified channel bandwidth.

Table 6.6.2.1.1-1: General E-UTRA spectrum emission mask

Spectrum emission limit (dBm)/ Channel bandwidth							
Δf_{OoB} (MHz)	1.4 MHz	3.0 MHz	5 MHz	10 MHz	15 MHz	20 MHz	Measurement bandwidth
$\pm 0-1$	-10	-13	-15	-18	-20	-21	30 kHz
$\pm 1-2.5$	-10	-10	-10	-10	-10	-10	1 MHz
$\pm 2.5-2.8$	-25	-10	-10	-10	-10	-10	1 MHz
$\pm 2.8-5$		-10	-10	-10	-10	-10	1 MHz
$\pm 5-6$		-25	-13	-13	-13	-13	1 MHz
$\pm 6-10$			-25	-13	-13	-13	1 MHz
$\pm 10-15$				-25	-13	-13	1 MHz
$\pm 15-20$					-25	-13	1 MHz
$\pm 20-25$						-25	1 MHz

NOTE: As a general rule, the resolution bandwidth of the measuring equipment should be equal to the measurement bandwidth. However, to improve measurement accuracy, sensitivity and efficiency, the resolution bandwidth may be smaller than the measurement bandwidth. When the resolution bandwidth is smaller than the measurement bandwidth, the result should be integrated over the measurement bandwidth in order to obtain the equivalent noise bandwidth of the measurement bandwidth.

6.6.2.1A Spectrum emission mask for CA

For inter-band carrier aggregation with uplink assigned to two E-UTRA bands, the spectrum emission mask of the UE is defined per component carrier while both component carriers are active and the requirements are specified in subclauses 6.6.2.1 and 6.6.2.2. If for some frequency spectrum emission masks of component carriers overlap then spectrum emission mask allowing higher power spectral density applies for that frequency. If for some frequency a component carrier spectrum emission mask overlaps with the channel bandwidth of another component carrier, then the emission mask does not apply for that frequency.

For intra-band contiguous carrier aggregation the spectrum emission mask of the UE applies to frequencies (Δf_{OoB}) starting from the \pm edge of the aggregated channel bandwidth (Table 5.6A-1) For intra-band contiguous carrier aggregation the bandwidth class C, the power of any UE emission shall not exceed the levels specified in Table 6.6.2.1A-1 for the specified channel bandwidth.

Table 6.6.2.1A-1: General E-UTRA CA spectrum emission mask for Bandwidth Class C

Spectrum emission limit [dBm]/BW _{Channel_CA}							
Δf_{OoB} (MHz)	25RB+100RB (24.95MHz)	50RB+75RB (24.75 MHz)	50RB+100RB (29.9 MHz)	75RB+75RB (30 MHz)	75RB+100RB (34.85 MHz)	100RB+100RB (39.8 MHz)	Measurement bandwidth
\pm 0-1	-22	-22	-22.5	-22.5	-23.5	-24	30 kHz
\pm 1-5	-10	-10	-10	-10	-10	-10	1 MHz
\pm 5-24.75	-13	-13	-13	-13	-13	-13	1 MHz
\pm 24.75-24.95	-13	-25	-13	-13	-13	-13	1 MHz
\pm 24.95-29.75	-25	-25	-13	-13	-13	-13	1 MHz
\pm 29.75-29.9	-25		-13	-13	-13	-13	1 MHz
\pm 29.9-29.95	-25		-25	-13	-13	-13	1 MHz
\pm 29.95-30			-25	-13	-13	-13	1 MHz
\pm 30-34.85			-25	-25	-13	-13	1 MHz
\pm 34.85-34.9			-25	-25	-25	-13	1 MHz
\pm 34.9-35				-25	-25	-13	1 MHz
\pm 35-39.8					-25	-13	1 MHz
\pm 39.8-39.85					-25	-25	1 MHz
\pm 39.85-44.8						-25	1 MHz

For intra-band non-contiguous carrier aggregation transmission the spectrum emission mask requirement is defined as a composite spectrum emissions mask. Composite spectrum emission mask applies to frequencies up to $\pm \Delta f_{\text{OoB}}$ starting from the edges of the sub-blocks. Composite spectrum emission mask is defined as follows

- Composite spectrum emission mask is a combination of individual sub-block spectrum emissions masks
- In case the sub-block consist of one component carrier the sub-block general spectrum emission mask is defined in subclause 6.6.2.1.1
- If for some frequency sub-block spectrum emission masks overlap then spectrum emission mask allowing higher power spectral density applies for that frequency
- If for some frequency a sub-block spectrum emission mask overlaps with the sub-block bandwidth of another sub-block, then the emission mask does not apply for that frequency.

6.6.2.2 Additional spectrum emission mask

This requirement is specified in terms of an "additional spectrum emission" requirement.

6.6.2.2.1 Minimum requirement (network signalled value "NS_03", "NS_11", "NS_20", and "NS_21")

Additional spectrum emission requirements are signalled by the network to indicate that the UE shall meet an additional requirement for a specific deployment scenario as part of the cell handover/broadcast message.

When "NS_03", "NS_11", "NS_20" or "NS_21" is indicated in the cell, the power of any UE emission shall not exceed the levels specified in Table 6.6.2.2.1-1.

Table 6.6.2.2.1-1: Additional requirements

Δf_{OoB} (MHz)	Spectrum emission limit (dBm)/ Channel bandwidth						Measurement bandwidth
	1.4 MHz	3.0 MHz	5 MHz	10 MHz	15 MHz	20 MHz	
$\pm 0-1$	-10	-13	-15	-18	-20	-21	30 kHz
$\pm 1-2.5$	-13	-13	-13	-13	-13	-13	1 MHz
$\pm 2.5-2.8$	-25	-13	-13	-13	-13	-13	1 MHz
$\pm 2.8-5$		-13	-13	-13	-13	-13	1 MHz
$\pm 5-6$		-25	-13	-13	-13	-13	1 MHz
$\pm 6-10$			-25	-13	-13	-13	1 MHz
$\pm 10-15$				-25	-13	-13	1 MHz
$\pm 15-20$					-25	-13	1 MHz
$\pm 20-25$						-25	1 MHz

NOTE: As a general rule, the resolution bandwidth of the measuring equipment should be equal to the measurement bandwidth. However, to improve measurement accuracy, sensitivity and efficiency, the resolution bandwidth may be smaller than the measurement bandwidth. When the resolution bandwidth is smaller than the measurement bandwidth, the result should be integrated over the measurement bandwidth in order to obtain the equivalent noise bandwidth of the measurement bandwidth.

6.6.2.2.2 Minimum requirement (network signalled value "NS_04")

Additional spectrum emission requirements are signalled by the network to indicate that the UE shall meet an additional requirement for a specific deployment scenario as part of the cell handover/broadcast message.

When "NS_04" is indicated in the cell, the power of any UE emission shall not exceed the levels specified in Table 6.6.2.2.2-1.

Table 6.6.2.2.2-1: Additional requirements

Δf_{OoB} (MHz)	Spectrum emission limit (dBm)/ Channel bandwidth				Measurement bandwidth
	5 MHz	10 MHz	15 MHz	20 MHz	
$\pm 0-1$	-15	-18	-20	-21	30 kHz
$\pm 1-2.5$	-10	-10	-10	-10	1 MHz
$\pm 2.5-2.8$	-10	-10	-10	-10	1 MHz
$\pm 2.8-5$	-10	-10	-10	-10	1 MHz
$\pm 5-6$	-13	-13	-13	-13	1 MHz
$\pm 6-9$	-25	-13	-13	-13	1 MHz
$\pm 9-10$	-25	-25	-13	-13	1 MHz
$\pm 10-13.5$		-25	-13	-13	1 MHz
$\pm 13.5-15$		-25	-25	-13	1 MHz
$\pm 15-18$			-25	-13	1 MHz
$\pm 18-20$			-25	-25	1 MHz
$\pm 20-25$				-25	1 MHz

Note: As a general rule, the resolution bandwidth of the measuring equipment should be equal to the measurement bandwidth. However, to improve measurement accuracy, sensitivity and efficiency, the resolution bandwidth may be smaller than the measurement bandwidth. When the resolution bandwidth is smaller than the measurement bandwidth, the result should be integrated over the measurement bandwidth in order to obtain the equivalent noise bandwidth of the measurement bandwidth.

6.6.2.2.3 Minimum requirement (network signalled value "NS_06" or "NS_07")

Additional spectrum emission requirements are signalled by the network to indicate that the UE shall meet an additional requirement for a specific deployment scenario as part of the cell handover/broadcast message.

When "NS_06" or "NS_07" is indicated in the cell, the power of any UE emission shall not exceed the levels specified in Table 6.6.2.2.3-1.

Table 6.6.2.2.3-1: Additional requirements

Δf_{OoB} (MHz)	Spectrum emission limit (dBm)/ Channel bandwidth				
	1.4 MHz	3.0 MHz	5 MHz	10 MHz	Measurement bandwidth
$\pm 0-0.1$	-13	-13	-15	-18	30 kHz
$\pm 0.1-1$	-13	-13	-13	-13	100 kHz
$\pm 1-2.5$	-13	-13	-13	-13	1 MHz
$\pm 2.5-2.8$	-25	-13	-13	-13	1 MHz
$\pm 2.8-5$		-13	-13	-13	1 MHz
$\pm 5-6$		-25	-13	-13	1 MHz
$\pm 6-10$			-25	-13	1 MHz
$\pm 10-15$				-25	1 MHz

NOTE: As a general rule, the resolution bandwidth of the measuring equipment should be equal to the measurement bandwidth. However, to improve measurement accuracy, sensitivity and efficiency, the resolution bandwidth may be smaller than the measurement bandwidth. When the resolution bandwidth is smaller than the measurement bandwidth, the result should be integrated over the measurement bandwidth in order to obtain the equivalent noise bandwidth of the measurement bandwidth.

6.6.2.2A Additional Spectrum Emission Mask for CA

This requirement is specified in terms of an "additional spectrum emission" requirement.

6.6.2.2A.1 Minimum requirement (network signalled value "CA_NS_04")

Additional spectrum emission requirements are signalled by the network to indicate that the UE shall meet an additional requirement for a specific deployment scenario as part of the cell handover/broadcast message.

When "CA_NS_04" is indicated in the cell, the power of any UE emission shall not exceed the levels specified in Table 6.6.2.2A.1-1.

Table 6.6.2.2A.1-1: Additional requirements

Δf_{OoB} (MHz)	Spectrum emission limit [dBm]/BW _{Channel_CA}						Measurement bandwidth
	50+75RB (24.75 MHz)	25+100RB (24.95 MHz)	50+100RB (29.9 MHz)	75+75RB (30 MHz)	75+100RB (34.85 MHz)	100+100RB (39.8 MHz)	
$\pm 0-1$	-22	-22	-22.5	-23	-23.5	-24	30 kHz
$\pm 1-5$	-10	-10	-10	-10	-10	-10	1 MHz
$\pm 5-22.95$	-13	-13	-13	-13	-13	-13	1 MHz
$\pm 22.95-23.25$	-13	-25	-13	-13	-13	-13	1 MHz
$\pm 23.25-27.9$	-25	-25	-13	-13	-13	-13	1 MHz
$\pm 27.9-28.5$	-25	-25	-25	-13	-13	-13	1 MHz
$\pm 28.5-29.75$	-25	-25	-25	-25	-13	-13	1 MHz
$\pm 29.75-29.95$		-25	-25	-25	-13	-13	1 MHz
$\pm 29.95-32.85$			-25	-25	-13	-13	1 MHz
$\pm 32.85-34.9$			-25	-25	-25	-13	1 MHz
$\pm 34.9-35$				-25	-25	-13	1 MHz
$\pm 35-37.8$					-25	-13	1 MHz
$\pm 37.8-39.85$					-25	-25	1 MHz
$\pm 39.85-44.8$						-25	1 MHz

Note: As a general rule, the resolution bandwidth of the measuring equipment should be equal to the measurement bandwidth. However, to improve measurement accuracy, sensitivity and efficiency, the resolution bandwidth may be smaller than the measurement bandwidth. When the resolution bandwidth is smaller than the measurement bandwidth, the result should be integrated over the measurement bandwidth in order to obtain the equivalent noise bandwidth of the measurement bandwidth.

6.6.2.3 Adjacent Channel Leakage Ratio

Adjacent Channel Leakage power Ratio (ACLR) is the ratio of the filtered mean power centred on the assigned channel frequency to the filtered mean power centred on an adjacent channel frequency. ACLR requirements for one E-UTRA carrier are specified for two scenarios for an adjacent E-UTRA and /or UTRA channel as shown in Figure 6.6.2.3-1.

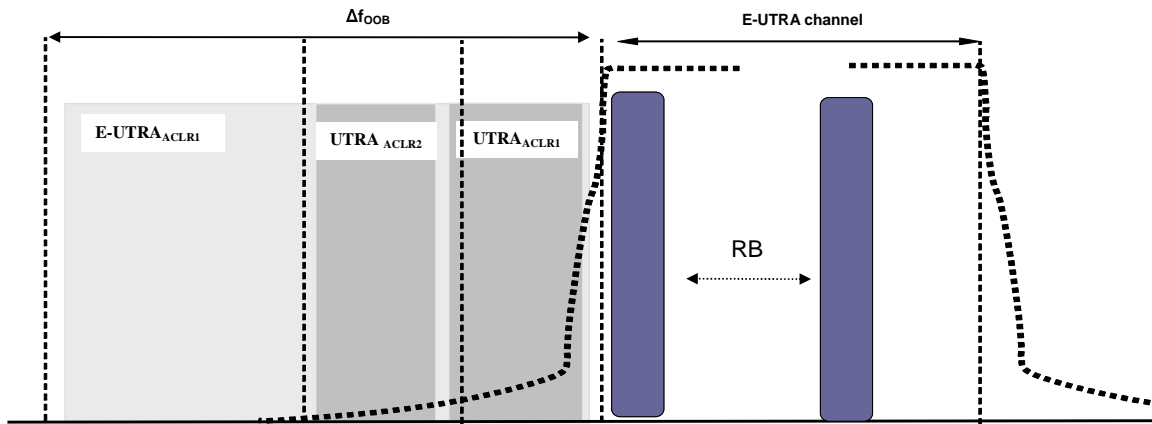

Figure 6.6.2.3-1: Adjacent Channel Leakage requirements for one E-UTRA carrier

6.6.2.3.1 Minimum requirement E-UTRA

E-UTRA Adjacent Channel Leakage power Ratio ($E-UTRA_{ACLR}$) is the ratio of the filtered mean power centred on the assigned channel frequency to the filtered mean power centred on an adjacent channel frequency at nominal channel spacing. The assigned E-UTRA channel power and adjacent E-UTRA channel power are measured with rectangular filters with measurement bandwidths specified in Table 6.6.2.3.1-1 and Table 6.6.2.3.1-2. If the measured adjacent channel power is greater than -50dBm then the $E-UTRA_{ACLR}$ shall be higher than the value specified in Table 6.6.2.3.1-1 and Table 6.6.2.3.1-2.

Table 6.6.2.3.1-1: General requirements for $E-UTRA_{ACLR}$

	Channel bandwidth / $E-UTRA_{ACLR1}$ / Measurement bandwidth					
	1.4 MHz	3.0 MHz	5 MHz	10 MHz	15 MHz	20 MHz
$E-UTRA_{ACLR1}$	30 dB	30 dB	30 dB	30 dB	30 dB	30 dB
E-UTRA channel Measurement bandwidth	1.08 MHz	2.7 MHz	4.5 MHz	9.0 MHz	13.5 MHz	18 MHz
Adjacent channel centre frequency offset [MHz]	+1.4 / -1.4	+3.0 / -3.0	+5 / -5	+10 / -10	+15 / -15	+20 / -20

Table 6.6.2.3.1-2: Additional $E-UTRA_{ACLR}$ requirements for Power Class 1

	Channel bandwidth / $E-UTRA_{ACLR1}$ / Measurement bandwidth					
	1.4 MHz	3.0 MHz	5 MHz	10 MHz	15 MHz	20 MHz
$E-UTRA_{ACLR1}$			37 dB	37 dB		
E-UTRA channel Measurement bandwidth			4.5 MHz	9.0 MHz		
Adjacent channel centre frequency offset [MHz]			+5 / -5	+10 / -10		
NOTE 1: $E-UTRA_{ACLR1}$ shall be applicable for $>23\text{dBm}$						

6.6.2.3.1A Void

6.6.2.3.1Aa Void

6.6.2.3.2 Minimum requirements UTRA

UTRA Adjacent Channel Leakage power Ratio ($UTRA_{ACLR}$) is the ratio of the filtered mean power centred on the assigned E-UTRA channel frequency to the filtered mean power centred on an adjacent(s) UTRA channel frequency.

UTRA Adjacent Channel Leakage power Ratio is specified for both the first UTRA adjacent channel ($UTRA_{ACLR1}$) and the 2nd UTRA adjacent channel ($UTRA_{ACLR2}$). The UTRA channel power is measured with a RRC bandwidth filter with roll-off factor $\alpha = 0.22$. The assigned E-UTRA channel power is measured with a rectangular filter with measurement bandwidth specified in Table 6.6.2.3.2-1. If the measured UTRA channel power is greater than -50dBm then the $UTRA_{ACLR}$ shall be higher than the value specified in Table 6.6.2.3.2-1.

Table 6.6.2.3.2-1: Requirements for $UTRA_{ACLR1/2}$

	Channel bandwidth / $UTRA_{ACLR1/2}$ / Measurement bandwidth					
	1.4 MHz	3.0 MHz	5 MHz	10 MHz	15 MHz	20 MHz
$UTRA_{ACLR1}$	33 dB	33 dB	33 dB	33 dB	33 dB	33 dB
Adjacent channel centre frequency offset [MHz]	$0.7+BW_{UTRA/2}$ / $-0.7-BW_{UTRA/2}$	$1.5+BW_{UTRA/2}$ / $-1.5-BW_{UTRA/2}$	$+2.5+BW_{UTRA/2}$ / $-2.5-BW_{UTRA/2}$	$+5+BW_{UTRA/2}$ / $-5-BW_{UTRA/2}$	$+7.5+BW_{UTRA/2}$ / $-7.5-BW_{UTRA/2}$	$+10+BW_{UTRA/2}$ / $-10-BW_{UTRA/2}$
$UTRA_{ACLR2}$	-	-	36 dB	36 dB	36 dB	36 dB
Adjacent channel centre frequency offset [MHz]	-	-	$+2.5+3*BW_{UTRA/2}$ / $-2.5-3*BW_{UTRA/2}$	$+5+3*BW_{UTRA/2}$ / $-5-3*BW_{UTRA/2}$	$+7.5+3*BW_{UTRA/2}$ / $-7.5-3*BW_{UTRA/2}$	$+10+3*BW_{UTRA/2}$ / $-10-3*BW_{UTRA/2}$
E-UTRA channel Measurement bandwidth	1.08 MHz	2.7 MHz	4.5 MHz	9.0 MHz	13.5 MHz	18 MHz
UTRA 5MHz channel Measurement bandwidth (Note 1)	3.84 MHz	3.84 MHz	3.84 MHz	3.84 MHz	3.84 MHz	3.84 MHz
UTRA 1.6MHz channel measurement bandwidth (Note 2)	1.28 MHz	1.28 MHz	1.28 MHz	1.28MHz	1.28MHz	1.28MHz
NOTE 1: Applicable for E-UTRA FDD co-existence with UTRA FDD in paired spectrum.						
NOTE 2: Applicable for E-UTRA TDD co-existence with UTRA TDD in unpaired spectrum.						

6.6.2.3.2A Minimum requirement UTRA for CA

For inter-band carrier aggregation with uplink assigned to two E-UTRA bands, the UTRA Adjacent Channel Leakage power Ratio ($UTRA_{ACLR}$) is the ratio of the filtered mean power centred on the assigned channel bandwidth on the component carrier to the filtered mean power centred on an adjacent channel frequency. The UTRA Adjacent Channel Leakage power Ratio is defined per carrier and the requirement is specified in subclause 6.6.2.3.2.

For intra-band contiguous carrier aggregation the UTRA Adjacent Channel Leakage power Ratio ($UTRA_{ACLR}$) is the ratio of the filtered mean power centred on the aggregated channel bandwidth to the filtered mean power centred on an adjacent(s) UTRA channel frequency.

For intra-band non-contiguous carrier aggregation when all sub-blocks consist of one component carrier the UTRA Adjacent Channel Leakage power Ratio ($UTRA_{ACLR}$) is the ratio of the sum of the filtered mean powers centered on the assigned sub-block frequencies to the filtered mean power centred on an adjacent(s) UTRA channel frequency. $UTRA_{ACLR1/2}$ requirements are applicable for all sub-blocks and are specified in Table 6.6.2.3.2A-2. $UTRA_{ACLR1}$ is required to be met in the sub-block gap when the gap bandwidth W_{gap} is $5\text{MHz} \leq W_{gap} < 15\text{MHz}$. Both $UTRA_{ACLR1}$ and $UTRA_{ACLR2}$ are required to be met in the sub-block gap when the gap bandwidth W_{gap} is $15\text{MHz} \leq W_{gap}$.

UTRA Adjacent Channel Leakage power Ratio is specified for both the first UTRA adjacent channel ($UTRA_{ACLR1}$) and the 2nd UTRA adjacent channel ($UTRA_{ACLR2}$). The UTRA channel power is measured with a RRC bandwidth filter with roll-off factor $\alpha = 0.22$. The assigned aggregated channel bandwidth power is measured with a rectangular filter with measurement bandwidth specified in Table 6.6.2.3.2A-1 for intraband contiguous carrier aggregation or 6.6.2.3.2A-2 for intraband non-contiguous carrier aggregation. If the measured UTRA channel power is greater than -50dBm then the $UTRA_{ACLR}$ shall be higher than the value specified in Table 6.6.2.3.2A-1 for intraband contiguous carrier aggregation or 6.6.2.3.2A-2 for intraband non-contiguous carrier aggregation.

Table 6.6.2.3.2A-1: Requirements for $UTRA_{ACLR1/2}$

	CA bandwidth class / $UTRA_{ACLR1/2}$ / measurement bandwidth
	CA bandwidth class C
$UTRA_{ACLR1}$	33 dB
Adjacent channel centre frequency offset (in MHz)	$\frac{+ BW_{Channel_CA} / 2 + BW_{UTRA/2}}{- BW_{Channel_CA} / 2 - BW_{UTRA/2}}$
$UTRA_{ACLR2}$	36 dB
Adjacent channel centre frequency offset (in MHz)	$\frac{+ BW_{Channel_CA} / 2 + 3*BW_{UTRA/2}}{- BW_{Channel_CA} / 2 - 3*BW_{UTRA/2}}$
CA E-UTRA channel Measurement bandwidth	$BW_{Channel_CA} - 2* BW_{GB}$
UTRA 5MHz channel Measurement bandwidth (Note 1)	3.84 MHz
UTRA 1.6MHz channel measurement bandwidth (Note 2)	1.28 MHz
NOTE 1: Applicable for E-UTRA FDD co-existence with UTRA FDD in paired spectrum.	
NOTE 2: Applicable for E-UTRA TDD co-existence with UTRA TDD in unpaired spectrum.	

Table 6.6.2.3.2A-2: Requirements for intraband non-contiguous CA $UTRA_{ACLR1/2}$

	$UTRA_{ACLR1/2}$ / measurement bandwidth
$UTRA_{ACLR1}$	33 dB
Adjacent channel centre frequency offset (in MHz)	$\frac{+ F_{edge,block,high} + BW_{UTRA/2}}{- F_{edge,block,low} - BW_{UTRA/2}}$
$UTRA_{ACLR2}$	36 dB
Adjacent channel centre frequency offset (in MHz)	$\frac{+ F_{edge,block,high} + 3*BW_{UTRA/2}}{- F_{edge,block,low} - 3*BW_{UTRA/2}}$
Sub-block measurement bandwidth	$BW_{Channel,block} - 2* BW_{GB}$
UTRA 5 MHz channel Measurement bandwidth (Note 1)	3.84 MHz
UTRA 1.6 MHz channel measurement bandwidth (Note 2)	1.28 MHz
NOTE 1: Applicable for E-UTRA FDD co-existence with UTRA FDD in paired spectrum.	
NOTE 2: Applicable for E-UTRA TDD co-existence with UTRA TDD in unpaired spectrum.	

6.6.2.3.3A Minimum requirements for CA E-UTRA

For intra-band contiguous carrier aggregation the carrier aggregation E-UTRA Adjacent Channel Leakage power Ratio (CA E-UTRA_{ACLR}) is the ratio of the filtered mean power centred on the aggregated channel bandwidth to the filtered mean power centred on an adjacent aggregated channel bandwidth at nominal channel spacing. The assigned aggregated channel bandwidth power and adjacent aggregated channel bandwidth power are measured with rectangular filters with measurement bandwidths specified in Table 6.6.2.3.3A-1. If the measured adjacent channel power is greater than –50dBm then the E-UTRA_{ACLR} shall be higher than the value specified in Table 6.6.2.3.3A-1.

Table 6.6.2.3.3A-1: General requirements for CA E-UTRA_{ACLR}

	CA bandwidth class / CA E-UTRA _{ACLR} / Measurement bandwidth
	CA bandwidth class C
CA E-UTRA _{ACLR}	30 dB
CA E-UTRA channel Measurement bandwidth	$BW_{\text{Channel_CA}} - 2 * BW_{\text{GB}}$
Adjacent channel centre frequency offset (in MHz)	$+ BW_{\text{Channel_CA}}$ / $- BW_{\text{Channel_CA}}$

For inter-band carrier aggregation with uplink assigned to two E-UTRA bands, E-UTRA Adjacent Channel Leakage power Ratio (E-UTRA_{ACLR}) is the ratio of the filtered mean power centred on the assigned channel bandwidth on a component carrier to the filtered mean power centred on an adjacent channel frequency. The E-UTRA Adjacent Channel Leakage power Ratio is defined per carrier and the requirement is specified in subclause 6.6.2.3.1.

For intra-band non-contiguous carrier aggregation when all sub-blocks consist of one component carrier the E-UTRA Adjacent Channel Leakage power Ratio (E-UTRA_{ACLR}) is the ratio of the sum of the filtered mean powers centred on the assigned sub-block frequencies to the filtered mean power centred on an adjacent channel frequency at nominal channel spacing. In case the sub-block gap bandwidth W_{gap} is smaller than of the sub-block bandwidth then for that sub-block no E-UTRA_{ACLR} requirement is set for the gap. In case the sub-block gap bandwidth W_{gap} is smaller than either of the sub-block bandwidths then no E-UTRA_{ACLR} requirement is set for the gap. The assigned E-UTRA sub-block power and adjacent E-UTRA channel power are measured with rectangular filters with measurement bandwidths specified in Table 6.6.2.3.3A-2. If the measured adjacent channel power is greater than –50dBm then the E-UTRA_{ACLR} shall be higher than the value specified in Table 6.6.2.3.3A-2.

Table 6.6.2.3.3A-2: General requirements for non-contiguous intraband CA E-UTRA_{ACLR}

	CC and adjacent channel bandwidth / E-UTRA _{ACLR} / Measurement bandwidth					
	1.4 MHz	3 MHz	5 MHz	10 MHz	15 MHz	20 MHz
E-UTRA _{ACLR1}	30 dB	30 dB	30 dB	30 dB	30 dB	30 dB
CC and adjacent channel measurement bandwidth [MHz]	1.08	2.7	4.5	9	13.5	18
Adjacent channel centre frequency offset [MHz]	+ 1.4 / - 1.4	+ 3 / - 3	+ 5 / - 5	+ 10 / - 10	+ 15 / - 15	+ 20 / - 20

6.6.2.4 Void

6.6.2.4.1 Void

6.6.2A Void

<reserved for future use>

6.6.2B Out of band emission for UL-MIMO

For UE supporting UL-MIMO, the requirements for Out of band emissions resulting from the modulation process and non-linearity in the transmitters are specified at each transmit antenna connector.

For UEs with two transmit antenna connectors in closed-loop spatial multiplexing scheme, the requirements in subclause 6.6.2 apply to each transmit antenna connector. The requirements shall be met with the UL-MIMO configurations specified in Table 6.2.2B-2.

If UE is configured for transmission on single-antenna port, the requirements in subclause 6.6.3 apply.

6.6.3 Spurious emissions

Spurious emissions are emissions which are caused by unwanted transmitter effects such as harmonics emission, parasitic emissions, intermodulation products and frequency conversion products, but exclude out of band emissions unless otherwise stated. The spurious emission limits are specified in terms of general requirements inline with SM.329 [2] and E-UTRA operating band requirement to address UE co-existence.

To improve measurement accuracy, sensitivity and efficiency, the resolution bandwidth may be smaller than the measurement bandwidth. When the resolution bandwidth is smaller than the measurement bandwidth, the result should be integrated over the measurement bandwidth in order to obtain the equivalent noise bandwidth of the measurement bandwidth.

6.6.3.1 Minimum requirements

Unless otherwise stated, the spurious emission limits apply for the frequency ranges that are more than F_{OOB} (MHz) in Table 6.6.3.1-1 from the edge of the channel bandwidth. The spurious emission limits in Table 6.6.3.1-2 apply for all transmitter band configurations (NRB) and channel bandwidths.

NOTE: For measurement conditions at the edge of each frequency range, the lowest frequency of the measurement position in each frequency range should be set at the lowest boundary of the frequency range plus MBW/2. The highest frequency of the measurement position in each frequency range should be set at the highest boundary of the frequency range minus MBW/2. MBW denotes the measurement bandwidth defined for the protected band.

Table 6.6.3.1-1: Boundary between E-UTRA out of band and spurious emission domain

Channel bandwidth	1.4 MHz	3.0 MHz	5 MHz	10 MHz	15 MHz	20 MHz
OOB boundary F _{OOB} (MHz)	2.8	6	10	15	20	25

Table 6.6.3.1-2: Spurious emissions limits

Frequency Range	Maximum Level	Measurement bandwidth	Note
9 kHz ≤ f < 150 kHz	-36 dBm	1 kHz	
150 kHz ≤ f < 30 MHz	-36 dBm	10 kHz	
30 MHz ≤ f < 1000 MHz	-36 dBm	100 kHz	
1 GHz ≤ f < 12.75 GHz	-30 dBm	1 MHz	
12.75 GHz ≤ f < 5 th harmonic of the upper frequency edge of the UL operating band in GHz	-30 dBm	1 MHz	1
NOTE 1: Applies for Band 22, Band 42 and Band 43			

6.6.3.1A Minimum requirements for CA

This clause specifies the spurious emission requirements for carrier aggregation.

NOTE: For measurement conditions at the edge of each frequency range, the lowest frequency of the measurement position in each frequency range should be set at the lowest boundary of the frequency range plus $MBW/2$. The highest frequency of the measurement position in each frequency range should be set at the highest boundary of the frequency range minus $MBW/2$. MBW denotes the measurement bandwidth defined for the protected band.

For inter-band carrier aggregation with uplink assigned to two E-UTRA bands, the spurious emission requirement Table 6.6.3.1-2 apply for the frequency ranges that are more than F_{OOB} as defined in Table 6.6.3.1-1 away from edges of the assigned channel bandwidth on a component carrier. If for some frequency a spurious emission requirement of individual component carrier overlaps with the spectrum emission mask or channel bandwidth of another component carrier then it does not apply.

NOTE: For inter-band carrier aggregation with uplink assigned to two E-UTRA bands the requirements in Table 6.6.3.1-2 could be verified by measuring spurious emissions at the specific frequencies where second and third order intermodulation products generated by the two transmitted carriers can occur; in that case, the requirements for remaining applicable frequencies in Table 6.6.3.1-2 would be considered to be verified by the measurements verifying the one uplink inter-band CA spurious emission requirement.

For intra-band contiguous carrier aggregation the spurious emission limits apply for the frequency ranges that are more than $FOOB$ (MHz) in Table 6.6.3.1A-1 from the edge of the aggregated channel bandwidth (Table 5.6A-1). For frequencies Δf_{OOB} greater than $FOOB$ as specified in Table 6.6.3.1A-1 the spurious emission requirements in Table 6.6.3.1-2 are applicable.

Table 6.6.3.1A-1: Boundary between E-UTRA out of band and spurious emission domain for intra-band contiguous carrier aggregation

CA Bandwidth Class	OOB boundary F_{OOB} (MHz)
A	Table 6.6.3.1-1
B	FFS
C	$BW_{Channel_CA} + 5$

For intra-band non-contiguous carrier aggregation transmission the spurious emission requirement is defined as a composite spurious emission requirement. Composite spurious emission requirement applies to frequency ranges that are more than F_{OOB} away from the edges of the sub-blocks. Composite spurious emission requirement is defined as follows

- a) Composite spurious emission requirement is a combination of individual sub-block spurious emission requirements
- b) In case the sub-block consist of one component carrier the sub-block spurious emission requirement and F_{OOB} are defined in subclause 6.6.3.1
- c) If for some frequency an individual sub-block spurious emission requirement overlaps with the general spectrum emission mask or the sub-block bandwidth of another sub-block then it does not apply

6.6.3.2 Spurious emission band UE co-existence

This clause specifies the requirements for the specified E-UTRA band, for coexistence with protected bands.

NOTE: For measurement conditions at the edge of each frequency range, the lowest frequency of the measurement position in each frequency range should be set at the lowest boundary of the frequency range plus $MBW/2$. The highest frequency of the measurement position in each frequency range should be set at the highest boundary of the frequency range minus $MBW/2$. MBW denotes the measurement bandwidth defined for the protected band.

Table 6.6.3.2-1: Requirements

E-UTRA Band	Spurious emission						
	Protected band	Frequency range (MHz)		Maximum Level (dBm)	MBW (MHz)	Note	
1	E-UTRA Band 1, 3, 5, 7, 8, 11, 18, 19, 20, 21, 22, 26, 27, 28, 31, 32, 38, 40, 41, 42, 43, 44	F _{DL_low}	-	F _{DL_high}	-50	1	
	E-UTRA Band 34	F _{DL_low}	-	F _{DL_high}	-50	1	15
	Frequency range	1880	-	1879.9	-50	1	15
	Frequency range	1895	-	1915	-15.5	5	15, 26, 27
	Frequency range	1915	-	1920	+1.6	5	15, 26, 27
2	E-UTRA Band 4, 5, 10, 12, 13, 14, 17, 23, 24, 26, 27, 28, 29, 30, 41, 42	F _{DL_low}	-	F _{DL_high}	-50	1	
	E-UTRA Band 2, 25	F _{DL_low}	-	F _{DL_high}	-50	1	15
	E-UTRA Band 43	F _{DL_low}	-	F _{DL_high}	-50	1	2
3	E-UTRA Band 1, 5, 7, 8, 11, 18, 19, 20, 21, 26, 27, 28, 31, 32, 33, 34, 38, 39, 40, 41, 43, 44	F _{DL_low}	-	F _{DL_high}	-50	1	
	E-UTRA Band 3	F _{DL_low}	-	F _{DL_high}	-50	1	15
	E-UTRA Band 22, 42	F _{DL_low}	-	F _{DL_high}	-50	1	2
	Frequency range	1884.5	-	1915.7	-41	0.3	
4	E-UTRA Band 2, 4, 5, 7, 10, 12, 13, 14, 17, 23, 24, 25, 26, 27, 28, 29, 30, 41, 43	F _{DL_low}	-	F _{DL_high}	-50	1	
	E-UTRA Band 42	F _{DL_low}	-	F _{DL_high}	-50	1	2
5	E-UTRA Band 1, 2, 3, 4, 5, 7, 8, 10, 12, 13, 14, 17, 23, 24, 25, 28, 29, 30, 31, 34, 38, 40, 42, 43	F _{DL_low}	-	F _{DL_high}	-50	1	
	E-UTRA Band 26	859	-	869	-27	1	
	E-UTRA Band 41	F _{DL_low}	-	F _{DL_high}	-50	1	2
6	E-UTRA Band 1, 9, 11, 34	F _{DL_low}	-	F _{DL_high}	-50	1	
	Frequency range	860	-	875	-37	1	
	Frequency range	875	-	895	-50	1	
	Frequency range	1884.5	-	1919.6	-41	0.3	7
		1884.5	-	1915.7			8
7	E-UTRA Band 1, 2, 3, 4, 5, 7, 8, 10, 12, 13, 14, 17, 20, 22, 26, 27, 28, 29, 30, 31, 32, 33, 34, 40, 42, 43	F _{DL_low}	-	F _{DL_high}	-50	1	
	Frequency range	2570	-	2575	+1.6	5	15, 21, 26
	Frequency range	2575	-	2595	-15.5	5	15, 21, 26
	Frequency range	2595	-	2620	-40	1	15, 21
8	E-UTRA Band 1, 20, 28, 31, 32, 33, 34, 38, 39, 40	F _{DL_low}	-	F _{DL_high}	-50	1	
	E-UTRA band 3, 7, 22, 41, 42, 43	F _{DL_low}	-	F _{DL_high}	-50	1	2
	E-UTRA Band 8	F _{DL_low}	-	F _{DL_high}	-50	1	15
	E-UTRA Band 11, 21	F _{DL_low}	-	F _{DL_high}	-50	1	23
	Frequency range	860	-	890	-40	1	15, 23
9	Frequency range	1884.5	-	1915.7	-41	0.3	8, 23
	E-UTRA Band 1, 3, 11, 18, 19, 21, 26, 28, 34	F _{DL_low}	-	F _{DL_high}	-50	1	
	E-UTRA Band 42	F _{DL_low}	-	F _{DL_high}	-50	1	2
	Frequency range	945	-	960	-50	1	
	Frequency range	1884.5	-	1915.7	-41	0.3	8
	Frequency range	2545	-	2575	-50	1	
10	Frequency range	2595	-	2645	-50	1	
	E-UTRA Band 2, 4, 5, 10, 12, 13, 14, 17, 23, 24, 25, 26, 27, 28, 29, 30, 41, 43	F _{DL_low}	-	F _{DL_high}	-50	1	
	E-UTRA Band 22, 42	F _{DL_low}	-	F _{DL_high}	-50	1	2
11	E-UTRA Band 1, 11, 18, 19, 21, 28, 34, 40, 42	F _{DL_low}	-	F _{DL_high}	-50	1	
	Frequency range	945	-	960	-50	1	
	Frequency range	1839.9	-	1879.9	-50	1	
	Frequency range	1884.5	-	1915.7	-41	0.3	8

	Frequency range	2545	-	2575	-50	1	
	Frequency range	2595	-	2645	-50	1	
12	E-UTRA Band 2, 5, 13, 14, 17, 23, 24, 25, 26, 27, 30, 41	F _{DL_low}	-	F _{DL_high}	-50	1	
	E-UTRA Band 4, 10	F _{DL_low}	-	F _{DL_high}	-50	1	2
	E-UTRA Band 12	F _{DL_low}	-	F _{DL_high}	-50	1	15
13	E-UTRA Band 2, 4, 5, 10, 12, 13, 17, 23, 25, 26, 27, 29, 41	F _{DL_low}	-	F _{DL_high}	-50	1	
	E-UTRA Band 14	F _{DL_low}	-	F _{DL_high}	-50	1	15
	E-UTRA Band 24, 30	F _{DL_low}	-	F _{DL_high}	-50	1	2
	Frequency range	769	-	775	-35	0.00625	15
	Frequency range	799	-	805	-35	0.00625	11, 15
14	E-UTRA Band 2, 4, 5, 10, 12, 13, 14, 17, 23, 24, 25, 26, 27, 29, 30, 41	F _{DL_low}	-	F _{DL_high}	-50	1	
	Frequency range	769	-	775	-35	0.00625	12, 15
	Frequency range	799	-	805	-35	0.00625	11, 12, 15
17	E-UTRA Band 2, 5, 13, 14, 17, 23, 24, 25, 26, 27, 30, 41	F _{DL_low}	-	F _{DL_high}	-50	1	
	E-UTRA Band 4, 10	F _{DL_low}	-	F _{DL_high}	-50	1	2
	E-UTRA Band 12	F _{DL_low}	-	F _{DL_high}	-50	1	15
18	E-UTRA Band 1, 3, 11, 21, 34, 40, 42	F _{DL_low}	-	F _{DL_high}	-50	1	
	Frequency range	758	-	799	-50	1	
	Frequency range	799	-	803	-40	1	15
	Frequency range	860	-	890	-40	1	
	Frequency range	945	-	960	-50	1	
	Frequency range	1884.5	-	1915.7	-41	0.3	8
	Frequency range	2545	-	2575	-50	1	
	Frequency range	2595	-	2645	-50	1	
19	E-UTRA Band 1, 3, 11, 21, 28, 34, 40, 42	F _{DL_low}	-	F _{DL_high}	-50	1	
	Frequency range	945	-	960	-50	1	
	Frequency range	1884.5	-	1915.7	-41	0.3	8
	Frequency range	2545	-	2575	-50	1	
	Frequency range	2595	-	2645	-50	1	
20	E-UTRA Band 1, 3, 7, 8, 22, 31, 32, 33, 34, 40, 43	F _{DL_low}	-	F _{DL_high}	-50	1	
	E-UTRA Band 20	F _{DL_low}	-	F _{DL_high}	-50	1	15
	E-UTRA Band 38, 42	F _{DL_low}	-	F _{DL_high}	-50	1	2
	Frequency range	758	-	788	-50	1	
21	E-UTRA Band 1, 3, 18, 19, 28, 34, 40, 42	F _{DL_low}	-	F _{DL_high}	-50	1	
	Frequency range	945	-	960	-50	1	
	Frequency range	1884.5	-	1915.7	-41	0.3	8
	Frequency range	2545	-	2575	-50	1	
	Frequency range	2595	-	2645	-50	1	
22	E-UTRA Band 1, 3, 7, 8, 20, 26, 27, 28, 31, 32, 33, 34, 38, 39, 40, 43	F _{DL_low}	-	F _{DL_high}	-50	1	
	Frequency range	3510	-	3525	-40	1	15
	Frequency range	3525	-	3590	-50	1	
23	E-UTRA Band 4, 5, 10, 12, 13, 14, 17, 23, 24, 26, 27, 29, 30, 41	F _{DL_low}	-	F _{DL_high}	-50	1	
24	E-UTRA Band 2, 4, 5, 10, 12, 13, 14, 17, 23, 24, 25, 26, 29, 30, 41	F _{DL_low}	-	F _{DL_high}	-50	1	
25	E-UTRA Band 4, 5, 10, 12, 13, 14, 17, 23, 24, 26, 27, 28, 29, 30, 41, 42	F _{DL_low}	-	F _{DL_high}	-50	1	
	E-UTRA Band 2	F _{DL_low}	-	F _{DL_high}	-50	1	15
	E-UTRA Band 25	F _{DL_low}	-	F _{DL_high}	-50	1	15
	E-UTRA Band 43	F _{DL_low}	-	F _{DL_high}	-50	1	2
26	E-UTRA Band 1, 2, 3, 4, 5, 10, 11, 12, 13, 14, 17, 18, 19, 21, 23, 24, 25, 26, 29, 30, 31, 34, 39, 40, 42, 43	F _{DL_low}	-	F _{DL_high}	-50	1	
	E-UTRA Band 41	F _{DL_low}	-	F _{DL_high}	-50	1	2
	Frequency range	703	-	799	-50	1	
	Frequency range	799	-	803	-40	1	15
	Frequency range	945	-	960	-50	1	
	Frequency range	1884.5	-	1915.7	-41	0.3	8

27	E-UTRA Band 1, 2, 3, 4, 5, 7, 10, 12, 13, 14, 17, 23, 25, 26, 27, 29, 30, 31, 38, 40, 41, 42, 43	F_{DL_low}	-	F_{DL_high}	-50	1	
	E-UTRA Band 28	F_{DL_low}	-	790	-50	1	
	Frequency range	799	-	805	-35	0.00625	
28	E-UTRA Band 1, 4, 10, 22, 32, 42, 43	F_{DL_low}	-	F_{DL_high}	-50	1	2
	E-UTRA Band 1	F_{DL_low}	-	F_{DL_high}	-50	1	19, 25
	E-UTRA Band 2, 3, 5, 7, 8, 18, 19, 20, 25, 26, 27, 31, 34, 38, 40, 41	F_{DL_low}	-	F_{DL_high}	-50	1	
	E-UTRA Band 11, 21	F_{DL_low}	-	F_{DL_high}	-50	1	19, 24
	Frequency range	470	-	694	-42	8	15, 35
	Frequency range	470	-	710	-26.2	6	34
	Frequency range	662	-	694	-26.2	6	15
	Frequency range	758	-	773	-32	1	15
	Frequency range	773	-	803	-50	1	
	Frequency range	1884.5	-	1915.7	-41	0.3	8, 19
30	E-UTRA Band 2, 4, 5, 7, 10, 12, 13, 14, 17, 23, 24, 25, 26, 27, 29, 30, 38, 41	F_{DL_low}	-	F_{DL_high}	-50	1	
31	E-UTRA Band 1, 5, 7, 8, 20, 22, 26, 27, 28, 31, 32, 33, 34, 38, 40, 42, 43	F_{DL_low}	-	F_{DL_high}	-50	1	
	E-UTRA Band 3	F_{DL_low}	-	F_{DL_high}	-50	1	2
	Frequency range	470	-	694	-42	8	
...							
33	E-UTRA Band 1, 7, 8, 20, 22, 28, 31, 32, 34, 38, 40, 42, 43	F_{DL_low}	-	F_{DL_high}	-50	1	5
	E-UTRA Band 3	F_{DL_low}	-	F_{DL_high}	-50	1	15
34	E-UTRA Band 1, 3, 7, 8, 11, 18, 19, 20, 21, 22, 26, 28, 31, 32, 33, 38, 39, 40, 41, 42, 43, 44	F_{DL_low}	-	F_{DL_high}	-50	1	5
	Frequency range	1884.5	-	1915.7	-41	0.3	8
35							
36							
37			-				
38	E-UTRA Band 1, 2, 3, 4, 5, 8, 10, 12, 13, 14, 17, 20, 22, 27, 28, 29, 30, 31, 32, 33, 34, 40, 42, 43	F_{DL_low}	-	F_{DL_high}	-50	1	
	Frequency range	2620	-	2645	-15.5	5	15, 22, 26
	Frequency range	2645	-	2690	-40	1	15, 22
39	E-UTRA Band 1, 8, 22, 26, 34, 40, 41, 42, 44	F_{DL_low}	-	F_{DL_high}	-50	1	
	Frequency range	1805		1855	-40	1	33
	Frequency range	1855		1880	-15.5	5	15, 26, 33
40	E-UTRA Band 1, 3, 5, 7, 8, 11, 18, 19, 20, 21, 22, 26, 27, 28, 31, 32, 33, 34, 38, 39, 41, 42, 43, 44	F_{DL_low}	-	F_{DL_high}	-50	1	
	Frequency range	1884.5	-	1915.7	-41	0.3	8
	Frequency range	1475	-	1518	-50	1	
	Frequency range	3300	-	4200	-50	1	
	Frequency range	4400	-	5000	-50	1	2
41	E-UTRA Band 1, 2, 3, 4, 5, 8, 10, 12, 13, 14, 17, 23, 24, 25, 26, 27, 28, 29, 30, 34, 39, 40, 42, 44	F_{DL_low}	-	F_{DL_high}	-50	1	
	E-UTRA Band 9, 11, 18, 19, 21	F_{DL_low}	-	F_{DL_high}	-50	1	30
	Frequency range	1884.5		1915.7	-41	0.3	8, 30
42	E-UTRA Band 1, 2, 3, 4, 5, 7, 8, 10, 11, 18, 19, 20, 21, 25, 26, 27, 28, 31, 32, 33, 34, 38, 40, 41, 44	F_{DL_low}	-	F_{DL_high}	-50	1	
	Frequency range	1884.5	-	1915.7	-41	0.3	8
43	E-UTRA Band 1, 2, 3, 4, 5, 7, 8, 10, 20, 25, 26, 27, 28, 31, 32, 33, 34, 38, 40	F_{DL_low}	-	F_{DL_high}	-50	1	
44	E-UTRA Band 1, 40, 42	F_{DL_low}	-	F_{DL_high}	-50	1	2
	E-UTRA Band 3, 5, 8, 34, 39, 41	F_{DL_low}	-	F_{DL_high}	-50	1	

- NOTE 1: F_{DL_low} and F_{DL_high} refer to each E-UTRA frequency band specified in Table 5.5-1
- NOTE 2: As exceptions, measurements with a level up to the applicable requirements defined in Table 6.6.3.1-2 are permitted for each assigned E-UTRA carrier used in the measurement due to 2nd, 3rd, 4th [or 5th] harmonic spurious emissions. Due to spreading of the harmonic emission the exception is also allowed for the first 1 MHz frequency range immediately outside the harmonic emission on both sides of the harmonic emission. This results in an overall exception interval centred at the harmonic emission of $(2\text{MHz} + N \times L_{CRB} \times 180\text{kHz})$, where N is 2, 3, 4, [5] for the 2nd, 3rd, 4th [or 5th] harmonic respectively. The exception is allowed if the measurement bandwidth (MBW) totally or partially overlaps the overall exception interval.
- NOTE 3: N/A
- NOTE 4: N/A
- NOTE 5: For non synchronised TDD operation to meet these requirements some restriction will be needed for either the operating band or protected band
- NOTE 6: N/A
- NOTE 7: Applicable when co-existence with PHS system operating in 1884.5-1919.6MHz.
- NOTE 8: Applicable when co-existence with PHS system operating in 1884.5-1915.7MHz.
- NOTE 9: N/A
- NOTE 10: N/A
- NOTE 11: Whether the applicable frequency range should be 793-805MHz instead of 799-805MHz is TBD
- NOTE 12: The emissions measurement shall be sufficiently power averaged to ensure a standard deviation < 0.5 dB
- NOTE 13: N/A
- NOTE 14: N/A
- NOTE 15: These requirements also apply for the frequency ranges that are less than F_{OOB} (MHz) in Table 6.6.3.1-1 and Table 6.6.3.1A-1 from the edge of the channel bandwidth.
- NOTE 16: N/A
- NOTE 17: N/A
- NOTE 18: N/A
- NOTE 19: Applicable when the assigned E-UTRA carrier is confined within 718 MHz and 748 MHz and when the channel bandwidth used is 5 or 10 MHz.
- NOTE 20: N/A
- NOTE 21: This requirement is applicable for any channel bandwidths within the range 2500 - 2570 MHz with the following restriction: for carriers of 15 MHz bandwidth when carrier centre frequency is within the range 2560.5 - 2562.5 MHz and for carriers of 20 MHz bandwidth when carrier centre frequency is within the range 2552 - 2560 MHz the requirement is applicable only for an uplink transmission bandwidth less than or equal to 54 RB.
- NOTE 22: This requirement is applicable for any channel bandwidths within the range 2570 - 2615 MHz with the following restriction: for carriers of 15 MHz bandwidth when carrier centre frequency is within the range 2605.5 - 2607.5 MHz and for carriers of 20 MHz bandwidth when carrier centre frequency is within the range 2597 - 2605 MHz the requirement is applicable only for an uplink transmission bandwidth less than or equal to 54 RB.
For carriers with channel bandwidth overlapping the frequency range 2615 - 2620 MHz the requirement applies with the maximum output power configured to +19 dBm in the IE *P-Max*.
- NOTE 23: This requirement is applicable only for the following cases:
- for carriers of 5 MHz channel bandwidth when carrier centre frequency (F_c) is within the range $902.5 \text{ MHz} \leq F_c < 907.5 \text{ MHz}$ with an uplink transmission bandwidth less than or equal to 20 RB
- for carriers of 5 MHz channel bandwidth when carrier centre frequency (F_c) is within the range $907.5 \text{ MHz} \leq F_c \leq 912.5 \text{ MHz}$ without any restriction on uplink transmission bandwidth.
- for carriers of 10 MHz channel bandwidth when carrier centre frequency (F_c) is $F_c = 910 \text{ MHz}$ with an uplink transmission bandwidth less than or equal to 32 RB with $RB_{start} > 3$.
- NOTE 24: As exceptions, measurements with a level up to the applicable requirement of -38 dBm/MHz is permitted for each assigned E-UTRA carrier used in the measurement due to 2nd harmonic spurious emissions. An exception is allowed if there is at least one individual RB within the transmission bandwidth (see Figure 5.6-1) for which the 2nd harmonic totally or partially overlaps the measurement bandwidth (MBW).
- NOTE 25: As exceptions, measurements with a level up to the applicable requirement of -36 dBm/MHz is permitted for each assigned E-UTRA carrier used in the measurement due to 3rd harmonic spurious emissions. An exception is allowed if there is at least one individual RB within the transmission bandwidth (see Figure 5.6-1) for which the 3rd harmonic totally or partially overlaps the measurement bandwidth (MBW).
- NOTE 26: For these adjacent bands, the emission limit could imply risk of harmful interference to UE(s) operating in the protected operating band.
- NOTE 27: This requirement is applicable for any channel bandwidths within the range 1920 - 1980 MHz with the following restriction: for carriers of 15 MHz bandwidth when carrier centre frequency is within the range 1927.5 - 1929.5 MHz and for carriers of 20 MHz bandwidth when carrier centre frequency is within the range 1930 - 1938 MHz the requirement is applicable only for an uplink transmission bandwidth less than or equal to 54 RB.
- NOTE 28: N/A

NOTE 29: N/A
NOTE 30: This requirement applies when the E-UTRA carrier is confined within 2545-2575MHz or 2595-2645MHz and the channel bandwidth is 10 or 20 MHz
NOTE 31: N/A
NOTE 32: Void
NOTE 33: This requirement is only applicable for carriers with bandwidth confined within 1885-1920 MHz (requirement for carriers with at least 1RB confined within 1880 - 1885 MHz is not specified). This requirement applies for an uplink transmission bandwidth less than or equal to 54 RB for carriers of 15 MHz bandwidth when carrier center frequency is within the range 1892.5 - 1894.5 MHz and for carriers of 20 MHz bandwidth when carrier center frequency is within the range 1895 - 1903 MHz.
NOTE 34: This requirement is applicable for 5 and 10 MHz E-UTRA channel bandwidth allocated within 718-728MHz. For carriers of 10 MHz bandwidth, this requirement applies for an uplink transmission bandwidth less than or equal to 30 RB with $RB_{start} > 1$ and $RB_{start} < 48$.
NOTE 35: This requirement is applicable in the case of a 10 MHz E-UTRA carrier confined within 703 MHz and 733 MHz, otherwise the requirement of -25 dBm with a measurement bandwidth of 8 MHz applies.

NOTE: The restriction on the maximum uplink transmission to 54 RB in Notes 21, 22, and 27 of Table 6.6.3.2-1 is intended for conformance testing and may be applied to network operation to facilitate coexistence when the aggressor and victim bands are deployed in the same geographical area. The applicable spurious emission requirement of -15.5 dBm/5MHz is a least restrictive technical condition for FDD/TDD coexistence and may have to be revised in the future.

6.6.3.2A Spurious emission band UE co-existence for CA

This clause specifies the requirements for the specified carrier aggregation configurations for coexistence with protected bands.

NOTE: For measurement conditions at the edge of each frequency range, the lowest frequency of the measurement position in each frequency range should be set at the lowest boundary of the frequency range plus $MBW/2$. The highest frequency of the measurement position in each frequency range should be set at the highest boundary of the frequency range minus $MBW/2$. MBW denotes the measurement bandwidth defined for the protected band.

For inter-band carrier aggregation with the uplink assigned to two E-UTRA bands, the requirements in Table 6.6.3.2A-0 apply on each component carrier with both component carriers are active.

NOTE: For inter-band carrier aggregation with uplink assigned to two E-UTRA bands the requirements in Table 6.6.3.2A-0 could be verified by measuring spurious emissions at the specific frequencies where second and third order intermodulation products generated by the two transmitted carriers can occur; in that case, the requirements for remaining applicable frequencies in Table 6.6.3.2A-0 would be considered to be verified by the measurements verifying the one uplink inter-band CA UE to UE co-existence requirements.

Table 6.6.3.2A-0: Requirements for uplink inter-band carrier aggregation (two bands)

E-UTRA CA Configuration	Spurious emission						
	Protected band	Frequency range (MHz)		Maximum Level (dBm)	MBW (MHz)	Note	
CA_1A-3A	E-UTRA Band 1, 5, 7, 8, 11, 18, 19, 20, 21, 26, 27, 28, 31, 32, 38, 40, 41, 43, 44	F _{DL_low}	-	F _{DL_high}	-50	1	
	E-UTRA band 3, 34	F _{DL_low}	-	F _{DL_high}	-50	1	3
	E-UTRA band 22, 42	F _{DL_low}	-	F _{DL_high}	-50	1	2
	Frequency range	1884.5	-	1915.7	-41	0.3	7
	Frequency range	1880	-	1895	-40	1	3,12
	Frequency range	1895	-	1915	-15.5	5	3, 12, 13
	Frequency range	1915	-	1920	+1.6	5	3, 12, 13
CA_1A-5A	E-UTRA Band 1, 5, 7, 8, 22, 28, 31, 38, 40, 42, 43	F _{DL_low}	-	F _{DL_high}	-50	1	
	E-UTRA band 3,34	F _{DL_low}	-	F _{DL_high}	-50	1	3
	E-UTRA band 26	859	-	869	-27	1	
	E-UTRA band 41	F _{DL_low}	-	F _{DL_high}	-50	1	2
CA_1A-7A	E-UTRA Band 1, 5, 7, 8, 20, 22, 26, 27, 28, 31,32, 40, 42, 43	F _{DL_low}	-	F _{DL_high}	-50	1	
	E-UTRA band 3, 34	F _{DL_low}	-	F _{DL_high}	-50	1	3
	Frequency range	1880	-	1895	-40	1	3,12
	Frequency range	1895	-	1915	-15.5	5	3, 12, 13
	Frequency range	1915	-	1920	+1.6	5	3, 12, 13
	Frequency range	2570	-	2575	+1.6	5	3, 13, 14
	Frequency range	2575	-	2595	-15.5	5	3, 13, 14
	Frequency range	2595	-	2620	-40	1	3, 14
CA_1A-8A	E-UTRA Band 1, 20, 28, 31, 32, 38, 40	F _{DL_low}	-	F _{DL_high}	-50	1	
	E-UTRA band 3	F _{DL_low}	-	F _{DL_high}	-50	1	2,3
	E-UTRA band 7, 22, 41, 42, 43	F _{DL_low}	-	F _{DL_high}	-50	1	2
	E-UTRA Band 8, 34	F _{DL_low}	-	F _{DL_high}	-50	1	3
	E-UTRA band 11, 21	F _{DL_low}	-	F _{DL_high}	-50	1	11
	Frequency range	860	-	890	-40	1	3, 11
	Frequency range	1884.5	-	1915.7	-41	0.3	7, 11
	Frequency range	1880	-	1895	-40	1	3,12
	Frequency range	1895	-	1915	-15.5	5	3, 12, 13
	Frequency range	1915	-	1920	+1.6	5	3, 12, 13
CA_1A-19A	E-UTRA Band 1, 3, 11, 21, 28, 40, 42	F _{DL_low}	-	F _{DL_high}	-50	1	
	E-UTRA Band 34	F _{DL_low}	-	F _{DL_high}	-50	1	3
	Frequency range	860	-	890	-40	1	3, 8
	Frequency range	945	-	960	-50	1	
	Frequency range	1884.5	-	1915.7	-41	0.3	3, 7
	Frequency range	2545	-	2575	-50	1	
	Frequency range	2595	-	2645	-50	1	
CA_1A-21A	E-UTRA Band 11	F _{DL_low}	-	F _{DL_high}	-35	1	3, 16
	E-UTRA Band 1, 3, 18, 19, 28, 34, 40, 42	F _{DL_low}	-	F _{DL_high}	-50	1	
	E-UTRA Band 21	F _{DL_low}	-	F _{DL_high}	-50	1	16
	Frequency range	1884.5	-	1915.7	-41	0.3	7
	Frequency range	945	-	960	-50	1	
	Frequency range	2545	-	2575	-50	1	
CA_2A-4A	E-UTRA Band 4, 5, 10, 12, 13, 14, 17, 22, 23, 24, 26, 27, 28, 29, 30, 41	F _{DL_low}	-	F _{DL_high}	-50	1	
	E-UTRA Band 2, 25	F _{DL_low}	-	F _{DL_high}	-50	1	3
	E-UTRA Band 42, 43	F _{DL_low}	-	F _{DL_high}	-50	1	2
CA_2A-13A	E-UTRA Band 4, 5,10,12,13,17, 22, 23, 26, 27, 29, 41, 42	F _{DL_low}	-	F _{DL_high}	-50	1	
	E-UTRA Band 2,14, 25	F _{DL_low}	-	F _{DL_high}	-50	1	3

	E-UTRA Band 24, 30, 43	F_{DL_low}	-	F_{DL_high}	-50	1	2
	Frequency range	769	-	775	-35	0.00625	3
	Frequency range	799	-	805	-35	0.00625	3, 9
CA_3A-5A	E-UTRA Band 1, 5, 7, 8, 22, 28, 31, 38, 40, 42, 43	F_{DL_low}	-	F_{DL_high}	-50	1	
	E-UTRA band 3,34	F_{DL_low}	-	F_{DL_high}	-50	1	3
	E-UTRA band 26	859	-	869	-27	1	
CA_3A-7A	E-UTRA Band 1, 5, 7, 8, 20, 26, 27, 28, 31, 32, 33, 34, 40, 43, 44	F_{DL_low}	-	F_{DL_high}	-50	1	
	E-UTRA band 3	F_{DL_low}	-	F_{DL_high}	-50	1	3
	E-UTRA band 22, 42	F_{DL_low}	-	F_{DL_high}	-50	1	2
	Frequency range	2570	-	2575	+1.6	5	3, 13, 14
	Frequency range	2575	-	2595	-15.5	5	3, 13, 14
	Frequency range	2595	-	2620	-40	1	3, 14
CA_3A-8A	E-UTRA Band 1, 20, 28, 31, 32, 33, 34, 38, 39, 40, 44	F_{DL_low}	-	F_{DL_high}	-50	1	
	E-UTRA band 3, 8	F_{DL_low}	-	F_{DL_high}	-50	1	2, 3
	E-UTRA band 11, 21	F_{DL_low}	-	F_{DL_high}	-50	1	11
	E-UTRA band 7, 22, 41, 42, 43	F_{DL_low}	-	F_{DL_high}	-50	1	2
	Frequency range	1884.5	-	1915.7	-41	0.3	4, 11
	Frequency range	860	-	890	-40	1	3,11,17
CA_3A-19A	E-UTRA Band 1, 11, 21, 28, 40	F_{DL_low}	-	F_{DL_high}	-50	1	
	E-UTRA Band 3, 34	F_{DL_low}	-	F_{DL_high}	-50	1	3
	E-UTRA Band 42	F_{DL_low}	-	F_{DL_high}	-50	1	2
	Frequency range	860	-	890	-40	1	3, 8
	Frequency range	945	-	960	-50	1	
	Frequency range	1884.5	-	1915.7	-41	0.3	3, 4
	Frequency range	2545	-	2575	-50	1	
	Frequency range	2595	-	2645	-50	1	
CA_3A-20A	E-UTRA Band 1, 7, 8, 31, 32, 33, 34, 40, 43	F_{DL_low}	-	F_{DL_high}	-50	1	
	E-UTRA Band 3, 20	F_{DL_low}	-	F_{DL_high}	-50	1	3
	E-UTRA Band 22, 38, 42	F_{DL_low}	-	F_{DL_high}	-50	1	2
	Frequency range	758	-	788	-50	1	
CA_3A-26A	E-UTRA Band 1, 5, 7, 11, 18, 19, 21, 26, 34, 39, 40, 43	F_{DL_low}	-	F_{DL_high}	-50	1	
	E-UTRA band 3	F_{DL_low}	-	F_{DL_high}	-50	1	3
	E-UTRA band 22, 41, 42	F_{DL_low}	-	F_{DL_high}	-50	1	2
	Frequency range	1884.5	-	1915.7	-41	0.3	4
	Frequency range	703	-	799	-50	1	
	Frequency range	799	-	803	-40	1	3
	Frequency range	851	-	859	-53	0.00625	15
	Frequency range	945	-	960	-50	1	
CA_4A-7A	E-UTRA Band 2, 4, 5, 7, 10, 12, 13, 14, 17, 26, 27, 28, 29, 30, 43	F_{DL_low}	-	F_{DL_high}	-50	1	
	E-UTRA band 42	F_{DL_low}	-	F_{DL_high}	-50	1	2
	Frequency range	2570	-	2575	+1.6	5	3, 13, 14
	Frequency range	2575	-	2595	-15.5	5	3, 13, 14
	Frequency range	2595	-	2620	-40	1	3, 14
CA_4A-12A	E-UTRA Band 2, 5, 7, 13, 14, 17, 22, 23, 24, 25, 26, 27, 30, 41, 43	F_{DL_low}	-	F_{DL_high}	-50	1	
	E-UTRA Band 4, 10, 42	F_{DL_low}	-	F_{DL_high}	-50	1	2
	E-UTRA Band 12	F_{DL_low}	-	F_{DL_high}	-50	1	3
CA_4A-13A	E-UTRA Band 2,4, 5, 7, 10,12,13,17, 22, 23,25, 26, 27, 29, 41, 43	F_{DL_low}	-	F_{DL_high}	-50	1	
	E-UTRA Band 14	F_{DL_low}	-	F_{DL_high}	-50	1	3
	E-UTRA Band 24, 30, 42	F_{DL_low}	-	F_{DL_high}	-50	1	2
	Frequency range	769	-	775	-35	0.00625	3
	Frequency range	799	-	805	-35	0.00625	3, 9
CA_4A-17A	E-UTRA Band 2, 5, 7,13, 14, 17, 22, 23, 24, 25, 26, 27, 30, 41, 43	F_{DL_low}	-	F_{DL_high}	-50	1	
	E-UTRA Band 4, 10, 42	F_{DL_low}	-	F_{DL_high}	-50	1	2
	E-UTRA Band 12	F_{DL_low}	-	F_{DL_high}	-50	1	3

CA_5A-7A	E-UTRA Band 1, 2, 3, 4, 5, 7, 8, 10, 12, 13, 14, 17, 22, 28, 29, 30, 31, 40, 42, 43	F_{DL_low}	-	F_{DL_high}	-50	1	
	E-UTRA band 26	859	-	869	-27	1	
	Frequency range	2570	-	2575	+1.6	5	3, 13, 14
	Frequency range	2575	-	2595	-15.5	5	3, 13, 14
	Frequency range	2595	-	2620	-40	1	3, 14
CA_5A-12A	E-UTRA Band 2, 5, 13, 14, 17, 22, 23, 24, 25, 30, 31, 42, 43	F_{DL_low}	-	F_{DL_high}	-50	1	
	E-UTRA band 4, 10, 41	F_{DL_low}	-	F_{DL_high}	-50	1	2
	E-UTRA band 26	859	-	869	-27	1	
	E-UTRA band 12	F_{DL_low}	-	F_{DL_high}	-50	1	3
CA_5A-17A	E-UTRA Band 2, 5, 13, 14, 17, 22, 23, 24, 25, 30, 31, 42, 43	F_{DL_low}	-	F_{DL_high}	-50	1	
	E-UTRA band 4, 10, 41	F_{DL_low}	-	F_{DL_high}	-50	1	2
	E-UTRA band 26	859	-	869	-27	1	
	E-UTRA band 12	F_{DL_low}	-	F_{DL_high}	-50	1	3
CA_7A-20A	E-UTRA Band 1,3, 7, 8, 22, 28, 31, 32, 33, 34, 40, 43	F_{DL_low}	-	F_{DL_high}	-50	1	
	E-UTRA Band 20	F_{DL_low}	-	F_{DL_high}	-50	1	3
	E-UTRA Band 42	F_{DL_low}	-	F_{DL_high}	-50	1	2
	Frequency range	2570	-	2575	+1.6	5	3, 13, 14
	Frequency range	2575	-	2595	-15.5	5	3, 13, 14
	Frequency range	2595	-	2620	-40	1	3, 14
CA_7A-28A	E-UTRA Band 2, 3, 5, 7, 8, 20, 26, 27, 31, 34, 40	F_{DL_low}	-	F_{DL_high}	-50	1	
	E-UTRA Band 1, 4, 10, 22, 32, 42, 43	F_{DL_low}	-	F_{DL_high}	-50	1	2
	E-UTRA Band 1	F_{DL_low}	-	F_{DL_high}	-50	1	5, 6
	Frequency range	758	-	773	-32	1	3
	Frequency range	773	-	803	-50	1	
	Frequency range	2570	-	2575	+1.6	5	3, 13, 14
	Frequency range	2575	-	2595	-15.5	5	3, 13, 14
	Frequency range	2595	-	2620	-40	1	3, 14
CA_19A-21A	E-UTRA Band 1, 3, 18, 19, 28, 34, 40, 42	F_{DL_low}	-	F_{DL_high}	-50	1	
	E-UTRA Band 11	F_{DL_low}	-	F_{DL_high}	-50	1	3, 16
	E-UTRA Band 21	F_{DL_low}	-	F_{DL_high}	-50	1	16
	Frequency range	860	-	890	-40	1	3, 8
	Frequency range	945	-	960	-50	1	
	Frequency range	1884.5	-	1915.7	-41	0.3	4
	Frequency range	2545	-	2575	-50	1	
	Frequency range	2595	-	2645	-50	1	
CA 39A-41A	E-UTRA Band 1, 8, 26, 34, 40, 42, 44	F_{DL_low}	-	F_{DL_high}	-50	1	
	Frequency range	1805	-	1855	-40	1	20
	Frequency range	1855	-	1880	-15.5	5	3, 13, 20
NOTE 1: F_{DL_low} and F_{DL_high} refer to each E-UTRA frequency band specified in Table 5.5-1							
NOTE 2: As exceptions, measurements with a level up to the applicable requirements defined in Table 6.6.3.1-2 are permitted for each assigned E-UTRA carrier used in the measurement due to 2 nd , 3 rd , 4 th [or 5 th] harmonic spurious emissions. In case the exceptions are allowed due to spreading of the harmonic emission the exception is also allowed for the first 1 MHz frequency range immediately outside the harmonic emission on both sides of the harmonic emission. This results in an overall exception interval centred at the harmonic emission of $(2\text{MHz} + N \times L_{CRB} \times 180\text{kHz})$, where N is 2, 3 or 4 for the 2 nd , 3 rd or 4 th harmonic respectively. The exception is allowed if the measurement bandwidth (MBW) totally or partially overlaps the overall exception interval.							
NOTE 3: These requirements also apply for the frequency ranges that are less than F_{OOB} (MHz) in Table 6.6.3.1-1 and Table 6.6.3.1A-1 from the edge of the aggregated channel bandwidth.							
NOTE 4: Applicable when co-existence with PHS system operating in 1884.5 -1915.7MHz.							
NOTE 5: Applicable when the assigned E-UTRA carrier is confined within 718 MHz and 748 MHz and when the channel bandwidth used is 5 or 10 MHz.							
NOTE 6: As exceptions, measurements with a level up to the applicable requirement of -36 dBm/MHz is permitted for each assigned E-UTRA carrier used in the measurement due to 3 rd harmonic spurious emissions. An exception is allowed if there is at least one individual RB within the transmission bandwidth (see Figure 5.6-1) for which the 3 rd harmonic totally or partially overlaps the measurement bandwidth (MBW).							

- NOTE 7: Applicable when NS_05 in section 6.6.3.3.1 is signalled by the network.
- NOTE 8: Applicable when NS_08 in subclause 6.6.3.3.3 is signalled by the network
- NOTE 9: Whether the applicable frequency range should be 793-805MHz instead of 799-805MHz is TBD.
- NOTE10: N/A
- NOTE 11: This requirement is applicable only for the following cases:
- for carriers of 5 MHz channel bandwidth when carrier centre frequency (F_c) is within the range $902.5 \text{ MHz} \leq F_c < 907.5 \text{ MHz}$ with an uplink transmission bandwidth less than or equal to 20 RB
 - for carriers of 5 MHz channel bandwidth when carrier centre frequency (F_c) is within the range $907.5 \text{ MHz} \leq F_c \leq 912.5 \text{ MHz}$ without any restriction on uplink transmission bandwidth.
 - for carriers of 10 MHz channel bandwidth when carrier centre frequency (F_c) is $F_c = 910 \text{ MHz}$ with an uplink transmission bandwidth less than or equal to 32 RB with $RB_{\text{start}} > 3$.
- NOTE 12: This requirement is applicable for any channel bandwidths within the range 1920 - 1980 MHz with the following restriction: for carriers of 15 MHz bandwidth when carrier centre frequency is within the range 1927.5 - 1929.5 MHz and for carriers of 20 MHz bandwidth when carrier centre frequency is within the range 1930 - 1938 MHz the requirement is applicable only for an uplink transmission bandwidth less than or equal to 54 RB.
- NOTE13: For these adjacent bands, the emission limit could imply risk of harmful interference to UE(s) operating in the protected operating band.
- NOTE 14: This requirement is applicable for any channel bandwidths within the range 2500 - 2570 MHz with the following restriction: for carriers of 15 MHz bandwidth when carrier centre frequency is within the range 2560.5 - 2562.5 MHz and for carriers of 20 MHz bandwidth when carrier centre frequency is within the range 2552 - 2560 MHz the requirement is applicable only for an uplink transmission bandwidth less than or equal to 54 RB.
- NOTE 15: Applicable when NS_15 in subclause 6.6.3.3.8 is signalled by the network.
- NOTE 16: Applicable when NS_09 in subclause 6.6.3.3.4 is signalled by the network
- NOTE 17: This requirement is applicable only when Band 3 transmission frequency is less than or equal to 1765 MHz.
- NOTE 18: This requirement applies when the E-UTRA carrier is confined within 2545-2575MHz or 2595-2645MHz and the channel bandwidth is 10 or 20 MHz
- NOTE 19: Void
- NOTE 20: This requirement is only applicable for carriers with bandwidth confined within 1885-1920 MHz (requirement for carriers with at least 1RB confined within 1880 - 1885 MHz is not specified). This requirement applies for an uplink transmission bandwidth less than or equal to 54 RB for carriers of 15 MHz bandwidth when carrier center frequency is within the range 1892.5 - 1894.5 MHz and for carriers of 20 MHz bandwidth when carrier center frequency is within the range 1895 - 1903 MHz.

Table 6.6.3.2A-1: Requirements for intraband carrier aggregation

E-UTRA CA Configuration	Spurious emission						
	Protected band	Frequency range (MHz)		Maximum Level (dBm)	MBW (MHz)	Note	
CA_1C	E-UTRA Band 1, 7, 8, 11, 18, 19, 20, 21, 22, 26, 27, 28, 31, 38, 40, 41, 42, 43, 44	F _{DL_low}	-	F _{DL_high}	-50	1	
	E-UTRA Band 3	F _{DL_low}	-	F _{DL_high}	-50	1	10
CA_3C	E-UTRA Band 1, 7, 8, 20, 26, 27, 28, 31, 33, 34, 38, 40, 41, 43, 44	F _{DL_low}	-	F _{DL_high}	-50	1	
	E-UTRA Band 3	F _{DL_low}	-	F _{DL_high}	-50	1	10
	E-UTRA Band 22, 42	F _{DL_low}	-	F _{DL_high}	-50	1	2
CA_7C	E-UTRA Band 1, 3, 7, 8, 20, 22, 27, 28, 29, 30, 31, 33, 34, 40, 42, 43	F _{DL_low}	-	F _{DL_high}	-50	1	
CA_38C	E-UTRA Band 1,3, 8, 20, 22, 27, 28, 29, 30, 31, 33, 34, 40, 42, 43	F _{DL_low}	-	F _{DL_high}	-50	1	
CA_39C	E-UTRA Band 22, 34, 40, 41, 42, 44	F _{DL_low}	-	F _{DL_high}	-50	1	
CA_40C	E-UTRA Band 1, 3, 5, 7, 8, 11, 18, 19, 20, 21, 22, 26, 27, 28, 33, 34, 38, 39, 41, 42, 43, 44	F _{DL_low}	-	F _{DL_high}	-50	1	
	Frequency range	1884.5	-	1915.7	-41	0.3	15
	Frequency range	1475	-	1518	-50	1	
	Frequency range	3300	-	4200	-50	1	
	Frequency range	4400	-	5000	-50	1	2
CA_41C	E-UTRA Band 1, 2, 3, 4, 5, 8, 10, 12, 13, 14, 17, 23, 24, 25, 26, 27, 28, 29, 30, 34, 39, 40, 42, 44	F _{DL_low}	-	F _{DL_high}	-50	1	
CA_42C	E-UTRA Band 1, 2, 3, 4, 5, 7, 8, 10, 11, 18, 19, 20, 21, 25, 26, 27, 28, 31, 33, 34, 38, 40, 41, 44	F _{DL_low}	-	F _{DL_high}	-50	1	
	Frequency range	1884.5	-	1915.7	-41	0.3	
NOTE 1: FDL_low and FDL_high refer to each E-UTRA frequency band specified in Table 5.5-1							
NOTE 2: As exceptions, measurements with a level up to the applicable requirements defined in Table 6.6.3.1-2 are permitted for each assigned E-UTRA carrier used in the measurement due to 2 nd , 3 rd , 4 th [or 5 th] harmonic spurious emissions. Due to spreading of the harmonic emission the exception is also allowed for the first 1 MHz frequency range immediately outside the harmonic emission on both sides of the harmonic emission. This results in an overall exception interval centred at the harmonic emission of (2MHz + N x L _{CRB} x 180kHz), where N is 2, 3, 4, [5] for the 2 nd , 3 rd , 4 th [or 5 th] harmonic respectively. The exception is allowed if the measurement bandwidth (MBW) totally or partially overlaps the overall exception interval							
NOTE 3: To meet these requirements some restriction will be needed for either the operating band or protected band							
NOTE 4: N/A							
NOTE 5: N/A							
NOTE 6: N/A							
NOTE 7: N/A							
NOTE 8: N/A							
NOTE 9: N/A							
NOTE 10: The requirement also applies for the frequency ranges that are less than F _{OOB} (MHz) in Table 6.6.3.1-1 and Table 6.6.3.1A-1 from the edge of the aggregated channel bandwidth.							
NOTE 11: N/A							
NOTE 12: N/A							
NOTE 13: N/A							
NOTE 14: N/A							
NOTE 15: Applicable when co-existence with PHS system operating in 1884.5 -1915.7MHz.							

Table 6.6.3.2A-2: Requirements for intraband non-contiguous CA

E-UTRA CA Configuration	Spurious emission						
	Protected band	Frequency range (MHz)		Maximum Level (dBm)	MBW (MHz)	Note	
CA_4A-4A	E-UTRA Band 2, 4, 5, 7, 10, 12, 13, 14, 17, 22, 23, 24, 25, 26, 27, 28, 29, 30, 41, 43	F _{DL_low}	-	F _{DL_high}	-50	1	
	E-UTRA Band 42	F _{DL_low}	-	F _{DL_high}	-50	1	2
NOTE 1: F _{DL_low} and F _{DL_high} refer to each E-UTRA frequency band specified in Table 5.5-1							
NOTE 2: As exceptions, measurements with a level up to the applicable requirements defined in Table 6.6.3.1-2 are permitted for each assigned E-UTRA carrier used in the measurement due to 2nd or 3rd harmonic spurious emissions. Due to spreading of the harmonic emission the exception is also allowed for the first 1 MHz frequency range immediately outside the harmonic emission on both sides of the harmonic emission. This results in an overall exception interval centred at the harmonic emission of (2MHz + N x LCRB x 180kHz), where N is 2 or 3 for the 2nd or 3rd harmonic respectively. The exception is allowed if the measurement bandwidth (MBW) totally or partially overlaps the overall exception interval.							

6.6.3.3 Additional spurious emissions

These requirements are specified in terms of an additional spectrum emission requirement. Additional spurious emission requirements are signalled by the network to indicate that the UE shall meet an additional requirement for a specific deployment scenario as part of the cell handover/broadcast message.

NOTE: For measurement conditions at the edge of each frequency range, the lowest frequency of the measurement position in each frequency range should be set at the lowest boundary of the frequency range plus MBW/2. The highest frequency of the measurement position in each frequency range should be set at the highest boundary of the frequency range minus MBW/2. MBW denotes the measurement bandwidth defined for the protected band.

6.6.3.3.1 Minimum requirement (network signalled value "NS_05")

When "NS_05" is indicated in the cell, the power of any UE emission shall not exceed the levels specified in Table 6.6.3.3.1-1. This requirement also applies for the frequency ranges that are less than FOOB (MHz) in Table 6.6.3.1-1 from the edge of the channel bandwidth.

Table 6.6.3.3.1-1: Additional requirements (PHS)

Frequency band (MHz)	Channel bandwidth / Spectrum emission limit (dBm)				Measurement bandwidth	Note
	5 MHz	10 MHz	15 MHz	20 MHz		
$1884.5 \leq f \leq 1915.7$	-41	-41	-41	-41	300 KHz	1

6.6.3.3.2 Minimum requirement (network signalled value "NS_07")

When "NS_07" is indicated in the cell, the power of any UE emission shall not exceed the levels specified in Table 6.6.3.3.2-1. This requirement also applies for the frequency ranges that are less than FOOB (MHz) in Table 6.6.3.1-1 from the edge of the channel bandwidth.

Table 6.6.3.3.2-1: Additional requirements

Frequency band (MHz)	Channel bandwidth / Spectrum emission limit (dBm)	Measurement bandwidth
	10 MHz	
$769 \leq f \leq 775$	-57	6.25 kHz
NOTE: The emissions measurement shall be sufficiently power averaged to ensure standard standard deviation < 0.5 dB.		

6.6.3.3.3 Minimum requirement (network signalled value "NS_08")

When "NS 08" is indicated in the cell, the power of any UE emission shall not exceed the levels specified in Table 6.6.3.3.3-1. This requirement also applies for the frequency ranges that are less than F_{OOB} (MHz) in Table 6.6.3.1-1 from the edge of the channel bandwidth.

Table 6.6.3.3.3-1: Additional requirement

Frequency band (MHz)	Channel bandwidth / Spectrum emission limit (dBm)			Measurement bandwidth
	5MHz	10MHz	15MHz	
$860 \leq f \leq 890$	-40	-40	-40	1 MHz

6.6.3.3.4 Minimum requirement (network signalled value "NS_09")

When "NS 09" is indicated in the cell, the power of any UE emission shall not exceed the levels specified in Table 6.6.3.3.4-1. This requirement also applies for the frequency ranges that are less than F_{OOB} (MHz) in Table 6.6.3.1-1 from the edge of the channel bandwidth.

Table 6.6.3.3.4-1: Additional requirement

Frequency band (MHz)	Channel bandwidth / Spectrum emission limit (dBm)			Measurement bandwidth
	5MHz	10MHz	15MHz	
$1475.9 \leq f \leq 1510.9$	-35	-35	-35	1 MHz

NOTE 1: Void.

NOTE 2: To improve measurement accuracy, A-MPR values for NS_09 specified in Table 6.2.4-1 in subclause 6.2.4 are derived based on 100 kHz RBW.

6.6.3.3.5 Minimum requirement (network signalled value "NS_12")

When "NS 12" is indicated in the cell, the power of any UE emission shall not exceed the levels specified in Table 6.6.3.3.5-1. This requirement also applies for the frequency ranges that are less than F_{OOB} (MHz) in Table 6.6.3.1-1 from the edge of the channel bandwidth.

Table 6.6.3.3.5-1: Additional requirements

Frequency band (MHz)	Channel bandwidth / Spectrum emission limit (dBm)	Measurement bandwidth
	1.4 MHz, 3 MHz, 5 MHz, 10 MHz, 15 MHz	
$806 \leq f \leq 813.5$	-42	6.25 kHz
NOTE 1: The requirement applies for E-UTRA carriers with lower channel edge at or above 814.2 MHz.		
NOTE 2: The emissions measurement shall be sufficiently power averaged to ensure a standard deviation < 0.5 dB.		

6.6.3.3.6 Minimum requirement (network signalled value "NS_13")

When "NS 13" is indicated in the cell, the power of any UE emission shall not exceed the levels specified in Table 6.6.3.3.6-1. This requirement also applies for the frequency ranges that are less than F_{OOB} (MHz) in Table 6.6.3.1-1 from the edge of the channel bandwidth.

Table 6.6.3.3.6-1: Additional requirements

Frequency band (MHz)	Channel bandwidth / Spectrum emission limit (dBm)	Measurement bandwidth
	1.4, 3, 5 MHz	
$806 \leq f \leq 816$	-42	6.25 kHz
NOTE 1: The requirement applies for E-UTRA carriers with lower channel edge at or above 819 MHz.		
NOTE 2: The emissions measurement shall be sufficiently power averaged to ensure a standard deviation < 0.5 dB.		

6.6.3.3.7 Minimum requirement (network signalled value “NS_14”)

When “NS 14” is indicated in the cell, the power of any UE emission shall not exceed the levels specified in Table 6.6.3.3.7-1. This requirement also applies for the frequency ranges that are less than F_{OOB} (MHz) in Table 6.6.3.1-1 from the edge of the channel bandwidth.

Table 6.6.3.3.7-1: Additional requirements

Frequency band (MHz)	Channel bandwidth / Spectrum emission limit (dBm)	Measurement bandwidth
	10 MHz, 15 MHz	
$806 \leq f \leq 816$	-42	6.25 kHz
NOTE 1: The requirement applies for E-UTRA carriers with lower channel edge at or above 824 MHz.		
NOTE 2: The emissions measurement shall be sufficiently power averaged to ensure a standard deviation < 0.5 dB.		

6.6.3.3.8 Minimum requirement (network signalled value “NS_15”)

When “NS 15” is indicated in the cell, the power of any UE emission shall not exceed the levels specified in Table 6.6.3.3.8-1. This requirement also applies for the frequency ranges that are less than F_{OOB} (MHz) in Table 6.6.3.1-1 from the edge of the channel bandwidth.

Table 6.6.3.3.8-1: Additional requirements

Frequency band (MHz)	Channel bandwidth / Spectrum emission limit (dBm)	Measurement bandwidth
	1.4 MHz, 3 MHz, 5 MHz, 10 MHz, 15 MHz	
$851 \leq f \leq 859$	-53	6.25 kHz
NOTE 1: The emissions measurement shall be sufficiently power averaged to ensure a standard deviation < 0.5 dB.		

6.6.3.3.9 Minimum requirement (network signalled value “NS_16”)

When “NS_16” is indicated in the cell, the power of any UE emission shall not exceed the levels specified in Table 6.6.3.3.9-1. This requirement also applies for the frequency ranges that are less than F_{OOB} (MHz) in Table 6.6.3.1-1 from the edge of the channel bandwidth.

Table 6.6.3.3.9-1: Additional requirements

Frequency band (MHz)	Channel bandwidth / Spectrum emission limit (dBm)	Measurement bandwidth	Note
	1.4, 3, 5, 10 MHz		
$790 \leq f \leq 803$	-32	1 MHz	

6.6.3.3.10 Minimum requirement (network signalled value “NS_17”)

When “NS_17” is indicated in the cell, the power of any UE emission shall not exceed the levels specified in Table 6.6.3.3.10-1. This requirement also applies for the frequency ranges that are less than F_{OOB} (MHz) in Table 6.6.3.3.1-1 from the edge of the channel bandwidth.

Table 6.6.3.3.10-1: Additional requirements

Frequency band (MHz)	Channel bandwidth / Spectrum emission limit (dBm)	Measurement bandwidth	Note
	5, 10 MHz		
$470 \leq f \leq 710$	-26.2	6 MHz	1
NOTE 1: Applicable when the assigned E-UTRA carrier is confined within 718 MHz and 748 MHz and when the channel bandwidth used is 5 or 10 MHz.			

6.6.3.3.11 Minimum requirement (network signalled value “NS_18”)

When “NS_18” is indicated in the cell, the power of any UE emission shall not exceed the levels specified in Table 6.6.3.3.11-1. This requirement also applies for the frequency ranges that are less than F_{OOB} (MHz) in Table 6.6.3.1-1 from the edge of the channel bandwidth.

Table 6.6.3.3.11-1: Additional requirements

Frequency band (MHz)	Channel bandwidth / Spectrum emission limit (dBm)	Measurement bandwidth	Note
	5, 10, 15, 20 MHz		
692-698	-26.2	6 MHz	

6.6.3.3.12 Minimum requirement (network signalled value “NS_19”)

When “NS_19” is indicated in the cell, the power of any UE emission shall not exceed the levels specified in Table 6.6.3.3.12-1. This requirement also applies for the frequency ranges that are less than F_{OOB} (MHz) in Table 6.6.3.1-1 from the edge of the channel bandwidth.

Table 6.6.3.3.12-1: Additional requirements

Frequency band (MHz)	Channel bandwidth / Spectrum emission limit (dBm)	Measurement bandwidth	Note
	3, 5, 10, 15, 20 MHz		
$662 \leq f \leq 694$	-25	8 MHz	

6.6.3.3.13 Minimum requirement (network signalled value “NS_11”)

When “NS_11” is indicated in the cell, the power of any UE emission shall not exceed the levels specified in Table 6.6.3.3.13-1. These requirements also apply for the frequency ranges that are less than F_{OOB} (MHz) in Table 6.6.3.1-1 and Table 6.6.3.1A-1 from the edge of the channel bandwidth.

Table 6.6.3.3.13-1: Additional requirements

Frequency band (MHz)	Channel bandwidth / Spectrum emission limit (dBm)	Measurement bandwidth
	1.4, 3, 5, 10, 15, 20 MHz	
E-UTRA Band 2	-50	1 MHz
$1998 \leq f \leq 1999$	-21	1 MHz
$1997 \leq f < 1998$	-27	1 MHz
$1996 \leq f < 1997$	-32	1 MHz
$1995 \leq f < 1996$	-37	1 MHz
$1990 \leq f < 1995$	-40	1 MHz

6.6.3.3.14 Minimum requirement (network signalled value "NS_20")

When "NS_20" is indicated in the cell, the power of any UE emission shall not exceed the levels specified in Table 6.6.3.3.14-1. These requirements also apply for the frequency ranges that are less than F_{OoB} (MHz) in Table 6.6.3.1-1 and Table 6.6.3.1A-1 from the edge of the channel bandwidth.

Table 6.6.3.3.14-1: Additional requirements

Frequency band (MHz)	Channel bandwidth / Spectrum emission limit (dBm)	Measurement bandwidth
	5, 10, 15, 20 MHz	
$1990 \leq f < 1999$	-40	1 MHz
$1999 \leq f \leq 2000$	-40	Note 1
Note 1: The measurement bandwidth is 1% of the applicable E-UTRA channel bandwidth.		

6.6.3.3.15 Minimum requirement (network signalled value "NS_21")

When "NS_21" is indicated in the cell, the power of any UE emission shall not exceed the levels specified in Table 6.6.3.3.15-1. These requirements also apply for the frequency ranges that are less than F_{OoB} (MHz) in Table 6.6.3.1-1 and Table 6.6.3.1A-1 from the edge of the channel bandwidth.

Table 6.6.3.3.15-1: Additional requirements

Frequency band (MHz)	Channel bandwidth / Spectrum emission limit (dBm)	Measurement bandwidth
	5, 10 MHz	
$2200 \leq f < 2288$	-40	1 MHz
$2288 \leq f < 2292$	-37	1 MHz
$2292 \leq f < 2296$	-31	1 MHz
$2296 \leq f < 2300$	-25	1 MHz
$2320 \leq f < 2324$	-25	1 MHz
$2324 \leq f < 2328$	-31	1 MHz
$2328 \leq f < 2332$	-37	1 MHz
$2332 \leq f \leq 2395$	-40	1 MHz

6.6.3.3.16 Minimum requirement (network signalled value "NS_22")

When "NS_22" is indicated in the cell, the power of any UE emission shall not exceed the levels specified in Table 6.6.3.3.16-1. This requirement also applies for the frequency ranges that are less than F_{OoB} (MHz) in Table 6.6.3.1-1 from the edge of the channel bandwidth.

Table 6.6.3.3.16-1: Additional requirement

Frequency band (MHz)	Channel bandwidth / Spectrum emission limit (dBm)	MBW
	5, 10, 15, 20 MHz	
3400 ≤ f ≤ 3800	-23 (Note 1, Note 3)	5 MHz
	-40 (Note 2)	1 MHz
<p>NOTE 1: This requirement applies within an offset between 5 MHz and 25 MHz from the lower and from the upper edge of the channel bandwidth, whenever these frequencies overlap with the specified frequency band.</p> <p>NOTE 2: This requirement applies from 3400 MHz to 25 MHz below the lower E-UTRA channel edge and from 25 MHz above the upper E-UTRA channel edge to 3800 MHz.</p> <p>NOTE 3: This emission limit might imply risk of harmful interference to UE(s) operating in the protected operating band</p>		

6.6.3.3.17 Minimum requirement (network signalled value "NS_23")

When "NS 23" is indicated in the cell, the power of any UE emission shall not exceed the levels specified in Table 6.6.3.3.17-1. This requirement also applies for the frequency ranges that are less than F_{OoB} (MHz) in Table 6.6.3.1-1 from the edge of the channel bandwidth.

Table 6.6.3.3.17-1: Additional requirement

Frequency band (MHz)	Channel bandwidth / Spectrum emission limit (dBm)	MBW
	5, 10, 15, 20 MHz	
3400 ≤ f ≤ 3800	-23 (Note 1, Note 4)	5 MHz
	-40 (Note 2)	1 MHz
<p>NOTE 1: This requirement applies within an offset between 5 MHz + $F_{\text{offset_NS_23}}$ and 25 MHz + $F_{\text{offset_NS_23}}$ from the lower and from the upper edges of the channel bandwidth, whenever these frequencies overlap with the specified frequency band.</p> <p>NOTE 2: This requirement applies from 3400 MHz to 25 MHz + $F_{\text{offset_NS_23}}$ below the lower E-UTRA channel edge and from 25 MHz + $F_{\text{offset_NS_23}}$ above the upper E-UTRA channel edge to 3800 MHz.</p> <p>NOTE 3: $F_{\text{offset_NS_23}}$ is: 0 MHz for 5 MHz channel BW, 5 MHz for 10 MHz channel BW, 9 MHz for 15 MHz channel BW and 12 MHz for 20 MHz channel BW.</p> <p>NOTE 4: This emission limit might imply risk of harmful interference to UE(s) operating in the protected operating band</p>		

6.6.3.3.18 Void

Table 6.6.3.3.18-1: Void

6.6.3.3.19 Minimum requirement (network signalled value "NS_04")

When "NS 04" is indicated in the cell, the power of any UE emission shall not exceed the levels specified in Table 6.6.3.3.19-1. This requirement also applies for the frequency ranges that are less than F_{OoB} (MHz) in Table 6.6.3.1-1 from the edge of the channel bandwidth.

Table 6.6.3.3.19-1: Additional requirements

Frequency band	Channel bandwidth / Spectrum emission limit (dBm)	Measurement bandwidth
	5, 10, 15, 20 MHz	
$2490.5 \text{ MHz} \leq f < 2496 \text{ MHz}$	-13	1 MHz
$9 \text{ kHz} < f < 2490.5 \text{ MHz}$	-25	1 MHz

6.6.3.3.20 Void

Table 6.6.3.3.20-1: Void

6.6.3.3.21 Void

Table 6.6.3.3.21-1: Void

6.6.3.3.22 Void

Table 6.6.3.3.22-1: Void

6.6.3.3.23 Void

Table 6.6.3.3.23-1: Void

6.6.3.3.24 Void

Table 6.6.3.3.24-1: Void

6.6.3.3.25 Void

Table 6.6.3.3.25-1: Void

6.6.3.3.26 Void

Table 6.6.3.3.26-1: Void

Table 6.6.3.3.26-2: Void

Table 6.6.3.3.26-3: Void

6.6.3.3.27 Void

Table 6.6.3.3.27-1: Void

Table 6.6.3.3.27-2: Void

Table 6.6.3.3.27-3: Void

Table 6.6.3.3.27-4: Void

6.6.3.3.28 Void

Table 6.6.3.3.28-1: Void

6.6.3.3.29 Void

Table 6.6.3.3.29-1: Void

6.6.3.3.30 Void

Table 6.6.3.3.30-1: Void

6.6.3.3.31 Void

Table 6.6.3.3.31-1: Void

6.6.3.3.32 Void

Table 6.6.3.3.32-1: Void

6.6.3.3.33 Void

Table 6.6.3.3.33-1: Void

6.6.3.3.34 Void

Table 6.6.3.3.34-1: Void**Table 6.6.3.3.34-2: Void**

6.6.3.3.35 Minimum requirement (network signalled value "NS_56")

When "NS_56" is indicated in the cell, the power of any UE emission shall not exceed the levels specified in Table 6.6.3.3.35-1. This requirement also applies for the frequency ranges that are less than F_{OOB} (MHz) in Table 6.6.3.1-1 from the edge of the channel bandwidth.

Table 6.6.3.3.35-1: Additional requirements

Frequency band (MHz)	Channel bandwidth / Spectrum emission limit ¹ (dBm)	Measurement bandwidth	NOTE
	5 MHz, 10MHz		
$1541 \leq f \leq 1559$	-102	2kHz	Averaged over any 2 millisecond active transmission interval
$1559 \leq f \leq 1608$	-85	700Hz	
$1608 \leq f \leq 1610$	$-85 + 5/2 (f-1608)$	700Hz	
$1610 \leq f \leq 1625$	$-80 + 66/15 (f-1610)$	700Hz	
$1541 \leq f \leq 1608$	-75	1MHz	Averaged over any 2 millisecond active transmission interval
$1608 \leq f \leq 1610$	$-75 + 5/2 (f-1608)$	1MHz	
$1610 \leq f \leq 1627.5$	$-70 + 57/17.5 (f-1610)$	1MHz	
1627.5	-37	4kHz	
$1638.5 \leq f \leq 1645.5$	-28	4kHz	
$1657.5 \leq f \leq 1660.5$	-28	4kHz	
NOTE 1: The EIRP requirement in regulation is converted to conducted requirement using a 0 dBi antenna.			

6.6.3.3A Additional spurious emissions for CA

These requirements are specified in terms of an additional spectrum emission requirement. Additional spurious emission requirements are signalled by the network to indicate that the UE shall meet an additional requirement for a specific deployment scenario as part of the cell reconfiguration message.

NOTE: For measurement conditions at the edge of each frequency range, the lowest frequency of the measurement position in each frequency range should be set at the lowest boundary of the frequency range plus MBW/2. The highest frequency of the measurement position in each frequency range should be set at the highest boundary of the frequency range minus MBW/2. MBW denotes the measurement bandwidth defined for the protected band.

6.6.3.3A.1 Minimum requirement for CA_1C (network signalled value "CA_NS_01")

When "CA_NS_01" is indicated in the cell, the power of any UE emission shall not exceed the levels specified in Table 6.6.3.3A.1-1. This requirement also applies for the frequency ranges that are less than F_{OOB} (MHz) in Table 6.6.3.1A-1 from the edge of the aggregated channel bandwidth.

Table 6.6.3.3A.1-1: Additional requirements (PHS)

Protected band	Frequency range (MHz)			Maximum Level (dBm)	MBW (MHz)	Note
E-UTRA band 34	FDL_low	-	FDL_high	-50	1	
Frequency range	1884.5	-	1915.7	-41	0.3	1

NOTE 1: Applicable when the aggregated channel bandwidth is confined within frequency range 1940 – 1980 MHz

6.6.3.3A.2 Minimum requirement for CA_1C (network signalled value "CA_NS_02")

When "CA_NS_02" is indicated in the cell, the power of any UE emission shall not exceed the levels specified in Table 6.6.3.3A.2-1. This requirement also applies for the frequency ranges that are less than F_{OOB} (MHz) in Table 6.6.3.1A-1 from the edge of the aggregated channel bandwidth.

Table 6.6.3.3A.2-1: Additional requirements

Protected band	Frequency range (MHz)			Maximum Level (dBm)	MBW (MHz)	Note
E-UTRA band 34	F _{DL_low}	-	F _{DL_high}	-50	1	
Frequency range	1900	-	1915	-15.5	5	1, 2
Frequency range	1915	-	1920	+1.6	5	1, 2

NOTE 1: The requirement also applies for the frequency ranges that are less than F_{OOB} (MHz) in Table 6.6.3.1-1 and Table 6.6.3.1A-1 from the edge of the channel bandwidth.
NOTE 2: For these adjacent bands, the emission limit could imply risk of harmful interference to UE(s) operating in the protected operating band.

6.6.3.3A.3 Minimum requirement for CA_1C (network signalled value "CA_NS_03")

When "CA_NS_03" is indicated in the cell, the power of any UE emission shall not exceed the levels specified in Table 6.6.3.3A.3-1. This requirement also applies for the frequency ranges that are less than F_{OOB} (MHz) in Table 6.6.3.1A-1 from the edge of the aggregated channel bandwidth.

Table 6.6.3.3A.3-1: Additional requirements

Protected band	Frequency range (MHz)			Maximum Level (dBm)	MBW (MHz)	Note
E-UTRA band 34	F _{DL_low}	-	F _{DL_high}	-50	1	
Frequency range	1880	-	1895	-40	1	
Frequency range	1895	-	1915	-15.5	5	1, 2
Frequency range	1915	-	1920	+1.6	5	1, 2

NOTE 1: The requirement also applies for the frequency ranges that are less than F_{OOB} (MHz) in Table 6.6.3.1-1 and Table 6.6.3.1A-1 from the edge of the channel bandwidth.
NOTE 2: For these adjacent bands, the emission limit could imply risk of harmful interference to UE(s) operating in the protected operating band.

6.6.3.3A.4 Minimum requirement for CA_38C (network signalled value "CA_NS_05")

When "CA_NS_05" is indicated in the cell, the power of any UE emission shall not exceed the levels specified in Table 6.6.3.3A.4-1. This requirement also applies for the frequency ranges that are less than F_{OOB} (MHz) in Table 6.6.3.1A-1 from the edge of the aggregated channel bandwidth. This requirement is applicable for carriers with aggregated channel bandwidths confined in 2570 - 2615 MHz.

Table 6.6.3.3A.4-1: Additional requirements

Protected band	Frequency range (MHz)			Maximum Level (dBm)	MBW (MHz)	Note
Frequency range	2620	-	2645	-15.5	5	1, 2, 3
Frequency range	2645	-	2690	-40	1	1, 3
NOTE 1: The requirement also applies for the frequency ranges that are less than F _{OOB} (MHz) in Table 6.6.3.1-1 and Table 6.6.3.1A-1 from the edge of the channel bandwidth.						
NOTE 2: For these adjacent bands, the emission limit could imply risk of harmful interference to UE(s) operating in the protected operating band.						
NOTE 3: This requirement is applicable for carriers with aggregated channel bandwidths confined in 2570-2615 MHz.						

6.6.3.3A.5 Minimum requirement for CA_7C (network signalled value "CA_NS_06")

When "CA_NS_06" is indicated in the cell, the power of any UE emission shall not exceed the levels specified in Table 6.6.3.3A.5-1. This requirement also applies for the frequency ranges that are less than F_{OOB} (MHz) in Table 6.6.3.1A-1 from the edge of the aggregated channel bandwidth.

Table 6.6.3.3A.5-1: Additional requirements

Protected band	Frequency range (MHz)			Maximum Level (dBm)	MBW (MHz)	Note
Frequency range	2570	-	2575	+1.6	5	1, 2
Frequency range	2575	-	2595	-15.5	5	1, 2
Frequency range	2595	-	2620	-40	1	
NOTE 1: The requirement also applies for the frequency ranges that are less than F _{OOB} (MHz) in Table 6.6.3.1-1 and Table 6.6.3.1A-1 from the edge of the channel bandwidth.						
NOTE 2: For these adjacent bands, the emission limit could imply risk of harmful interference to UE(s) operating in the protected operating band.						

6.6.3.3A.6 Minimum requirement for CA_39C (network signalled value "CA_NS_07")

When "CA_NS_07" is indicated in the cell, the power of any UE emission shall not exceed the levels specified in Table 6.6.3.3A.6-1. This requirement also applies for the frequency ranges that are less than F_{OOB} (MHz) in Table 6.6.3.1A-1 from the edge of the aggregated channel bandwidth.

Table 6.6.3.3A.6-1: Additional requirements

Protected band	Frequency range (MHz)			Maximum Level (dBm)	MBW (MHz)	Note
Frequency range	1805	-	1855	-40	1	1
Frequency range	1855	-	1880	-15.5	5	1, 2, 3
NOTE 1: This requirement is applicable for carriers with aggregated channel bandwidths confined in 1885-1920 MHz.						
NOTE 2: The requirement also applies for the frequency ranges that are less than F _{OOB} (MHz) in Table 6.6.3.1-1 and Table 6.6.3.1A-1 from the edge of the channel bandwidth.						
NOTE 3: For these adjacent bands, the emission limit could imply risk of harmful interference to UE(s) operating in the protected operating band.						

6.6.3.3A.7 Minimum requirement for CA_42C (network signalled value "CA_NS_08")

When "CA_NS_08" is indicated in the cell, the power of any UE emission shall not exceed the levels specified in Table 6.6.3.3A.7-1. This requirement also applies for the frequency ranges that are less than F_{OOB} (MHz) in Table 6.6.3.1A-1 from the edge of the aggregated channel bandwidth.

Table 6.6.3.3A.7-1: Additional requirements

Frequency band (MHz)	Aggregated bandwidth / Spectrum emission limit (dBm)	MBW
	25, 30, 35, 40 MHz (Note 1)	
$3400 \leq f \leq 3800$	-23 (Note 2, Note 4)	5 MHz
	-40 (Note 3)	1 MHz
NOTE 1: Possible aggregated bandwidth for CA_42C as specified in Table 5.6A.1-1. NOTE 2: This requirement applies within an offset between 5 MHz and 25 MHz from the lower and from the upper edge of the channel bandwidth, whenever these frequencies overlap with the specified frequency band. NOTE 3: This requirement applies from 3400 MHz to 25 MHz below the lower E-UTRA channel edge and from 25 MHz above the upper E-UTRA channel edge to 3800 MHz. NOTE 4: This emission limit might imply risk of harmful interference to UE(s) operating in the protected operating band.		

6.6.3.3A.8 Minimum requirement for CA_41C (network signalled value "CA_NS_04")

When "CA_NS_04" is indicated in the cell, the power of any UE emission shall not exceed the levels specified in Table 6.6.3.3A.8-1. This requirement also applies for the frequency ranges that are less than F_{OoB} (MHz) in Table 6.6.3.1A-1 from the edge of the aggregated channel bandwidth.

Table 6.6.3.3A.8-1: Additional requirements

Frequency band	Spectrum emission limit (dBm)	Measurement bandwidth
$2490.5 \text{ MHz} \leq f < 2495 \text{ MHz}$	-13	1 MHz
$9 \text{ kHz} < f < 2490.5 \text{ MHz}$	-25	1 MHz

6.6.3A Void

<reserved for future use>

6.6.3B Spurious emission for UL-MIMO

For UE supporting UL-MIMO, the requirements for Spurious emissions which are caused by unwanted transmitter effects such as harmonics emission, parasitic emissions, intermodulation products and frequency conversion products are specified at each transmit antenna connector.

For UEs with two transmit antenna connectors in closed-loop spatial multiplexing scheme, the requirements in subclause 6.6.3 apply to each transmit antenna connector. The requirements shall be met with the UL-MIMO configurations specified in Table 6.2.2B-1.

If UE is configured for transmission on single-antenna port, the general requirements in subclause 6.6.3 apply.

6.6A Void

6.6B Void

6.7 Transmit intermodulation

The transmit intermodulation performance is a measure of the capability of the transmitter to inhibit the generation of signals in its non linear elements caused by presence of the wanted signal and an interfering signal reaching the transmitter via the antenna.

6.7.1 Minimum requirement

User Equipment(s) transmitting in close vicinity of each other can produce intermodulation products, which can fall into the UE, or eNode B receive band as an unwanted interfering signal. The UE intermodulation attenuation is defined by the ratio of the mean power of the wanted signal to the mean power of the intermodulation product when an interfering CW signal is added at a level below the wanted signal at each of the transmitter antenna port with the other antenna port(s) if any is terminated. Both the wanted signal power and the intermodulation product power are measured through E-UTRA rectangular filter with measurement bandwidth shown in Table 6.7.1-1.

The requirement of transmitting intermodulation is prescribed in Table 6.7.1-1.

Table 6.7.1-1: Transmit Intermodulation

BW Channel (UL)	5MHz		10MHz		15MHz		20MHz	
Interference Signal Frequency Offset	5MHz	10MHz	10MHz	20MHz	15MHz	30MHz	20MHz	40MHz
Interference CW Signal Level	-40dBc							
Intermodulation Product	-29dBc	-35dBc	-29dBc	-35dBc	-29dBc	-35dBc	-29dBc	-35dBc
Measurement bandwidth	4.5MHz	4.5MHz	9.0MHz	9.0MHz	13.5MHz	13.5MHz	18MHz	18MHz

6.7.1A Minimum requirement for CA

User Equipment(s) transmitting in close vicinity of each other can produce intermodulation products, which can fall into the UE, or eNode B receive band as an unwanted interfering signal. The UE intermodulation attenuation is defined by the ratio of the mean power of the wanted signal to the mean power of the intermodulation product on both component carriers when an interfering CW signal is added at a level below the wanted signal at each of the transmitter antenna port with the other antenna port(s) if any is terminated. Both the wanted signal power and the intermodulation product power are measured through rectangular filter with measurement bandwidth shown in Table 6.7.1A-1.

For inter-band carrier aggregation with uplink assigned to two E-UTRA bands, the requirement is specified in Table 6.7.1-1 which shall apply on each component carrier with both component carriers active.

For intra-band contiguous carrier aggregation the requirement of transmitting intermodulation is specified in Table 6.7.1A-1.

Table 6.7.1A-1: Transmit Intermodulation

CA bandwidth class(UL)	C	
Interference Signal Frequency Offset	$BW_{\text{Channel_CA}}$	$2 \cdot BW_{\text{Channel_CA}}$
Interference CW Signal Level	-40dBc	
Intermodulation Product	-29dBc	-35dBc
Measurement bandwidth	$BW_{\text{Channel_CA}} - 2 \cdot BW_{\text{GB}}$	

6.7.1B Minimum requirement for UL-MIMO

For UE supporting UL-MIMO, the transmit intermodulation requirements are specified at each transmit antenna connector and the wanted signal is defined as the sum of output power at each transmit antenna connector.

For UEs with two transmit antenna connectors in closed-loop spatial multiplexing scheme, the requirements in subclause 6.7.1 apply to each transmit antenna connector. The requirements shall be met with the UL-MIMO configurations specified in Table 6.2.2B-2.

If UE is configured for transmission on single-antenna port, the requirements in subclause 6.7.1 apply.

6.8 Void

6.8.1 Void

6.8A Void

6.8B Time alignment error for UL-MIMO

For UE(s) with multiple transmit antenna connectors supporting UL-MIMO, this requirement applies to frame timing differences between transmissions on multiple transmit antenna connectors in the closed-loop spatial multiplexing scheme.

The time alignment error (TAE) is defined as the average frame timing difference between any two transmissions on different transmit antenna connectors.

6.8B.1 Minimum Requirements

For UE(s) with multiple transmit antenna connectors, the Time Alignment Error (TAE) shall not exceed 130 ns.

7 Receiver characteristics

7.1 General

Unless otherwise stated the receiver characteristics are specified at the antenna connector(s) of the UE. For UE(s) with an integral antenna only, a reference antenna(s) with a gain of 0 dBi is assumed for each antenna port(s). UE with an integral antenna(s) may be taken into account by converting these power levels into field strength requirements, assuming a 0 dBi gain antenna. For UEs with more than one receiver antenna connector, identical interfering signals shall be applied to each receiver antenna port if more than one of these is used (diversity).

The levels of the test signal applied to each of the antenna connectors shall be as defined in the respective sections below.

With the exception of subclause 7.3, the requirements shall be verified with the network signalling value NS_01 configured (Table 6.2.4-1).

All the parameters in clause 7 are defined using the UL reference measurement channels specified in Annexes A.2.2 and A.2.3, the DL reference measurement channels specified in Annex A.3.2 and using the set-up specified in Annex C.3.1.

For the additional requirements for intra-band non-contiguous carrier aggregation of two component carriers (one component carrier per sub-block), an in-gap test refers to the case when the interfering signal is located at a negative offset with respect to the assigned channel frequency of the highest carrier frequency and located at a positive offset with respect to the assigned channel frequency of the lowest carrier frequency.

For the additional requirements for intra-band non-contiguous carrier aggregation of two component carriers (one component carrier per sub-block), an out-of-gap test refers to the case when the interfering signal(s) is (are) located at a positive offset with respect to the assigned channel frequency of the highest carrier frequency, or located at a negative offset with respect to the assigned channel frequency of the lowest carrier frequency.

For the additional requirements for intra-band non-contiguous carrier aggregation of two component carriers with channel bandwidth larger than or equal to 5 MHz (one component carrier per sub-block), the existing adjacent channel selectivity requirements, in-band blocking requirements (for each case), and narrow band blocking requirements apply for in-gap tests only if the corresponding interferer frequency offsets with respect to the two measured carriers satisfy the following condition in relation to the sub-block gap size W_{gap} for at least one of these carriers $j, j = 1, 2$, so that the interferer frequency position does not change the nature of the core requirement tested:

$$W_{\text{gap}} \geq 2 \cdot |F_{\text{Interferer (offset)}_j} - BW_{\text{Channel}(j)}|$$

where $F_{\text{Interferer (offset)}_j}$ is the interferer frequency offset with respect to carrier j as specified in subclause 7.5.1, subclause 7.6.1 and subclause 7.6.3 for the respective requirement and $BW_{\text{Channel}(j)}$ the channel bandwidth of carrier j . The interferer frequency offsets for adjacent channel selectivity, each in-band blocking case and narrow-band blocking shall be tested separately with a single in-gap interferer at a time.

For a ProSe UE that supports both ProSe Direct Discovery and ProSe Direct Communication, the receiver characteristics specified in clause 7 for ProSe Direct Communication shall apply.

For ProSe Direct Discovery and ProSe Direct Communication on E-UTRA ProSe operating bands that correspond to TDD E-UTRA operating bands as specified in subclause 5.5D, the only additional requirement for ProSe specified in subclause 7.4.1D is applicable.

7.2 Diversity characteristics

The requirements in Section 7 assume that the receiver is equipped with two Rx port as a baseline. These requirements apply to all UE categories unless stated otherwise. Requirements for 4 ports are FFS. With the exception of subclause 7.9 all requirements shall be verified by using both (all) antenna ports simultaneously.

For a category 0 UE the requirements in Section 7 assume that the receiver is equipped with single Rx port.

7.3 Reference sensitivity power level

The reference sensitivity power level REFSSENS is the minimum mean power applied to both the UE antenna ports for all UE categories except category 0, or to the single antenna port for UE category 0, at which the throughput shall meet or exceed the requirements for the specified reference measurement channel.

The throughput for the REFSSENS test is measured based on the Transmission Mode 1 unless specified otherwise.

7.3.1 Minimum requirements (QPSK)

The throughput shall be $\geq 95\%$ of the maximum throughput of the reference measurement channels as specified in Annexes A.2.2, A.2.3 and A.3.2 (with one sided dynamic OCN Pattern OP.1 FDD/TDD for the DL-signal as described in Annex A.5.1.1/A.5.2.1) with parameters specified in Table 7.3.1-1 and Table 7.3.1-2

Table 7.3.1-1: Reference sensitivity QPSK P_{REFSENS}

Channel bandwidth							
E-UTRA Band	1.4 MHz (dBm)	3 MHz (dBm)	5 MHz (dBm)	10 MHz (dBm)	15 MHz (dBm)	20 MHz (dBm)	Duplex Mode
1			-100	-97	-95.2	-94	FDD
2	-102.7	-99.7	-98	-95	-93.2	-92	FDD
3	-101.7	-98.7	-97	-94	-92.2	-91	FDD
4	-104.7	-101.7	-100	-97	-95.2	-94	FDD
5	-103.2	-100.2	-98	-95			FDD
6			-100	-97			FDD
7			-98	-95	-93.2	-92	FDD
8	-102.2	-99.2	-97	-94			FDD
9			-99	-96	-94.2	-93	FDD
10			-100	-97	-95.2	-94	FDD
11			-100	-97			FDD
12	-101.7	-98.7	-97	-94			FDD
13			-97	-94			FDD
14			-97	-94			FDD
...							
17			-97	-94			FDD
18			-100 ⁷	-97 ⁷	-95.2 ⁷		FDD
19			-100	-97	-95.2		FDD
20			-97	-94	-91.2	-90	FDD
21			-100	-97	-95.2		FDD
22			-97	-94	-92.2	-91	FDD
23	-104.7	-101.7	-100	-97	-95.2	-94	FDD
24			-100	-97			FDD
25	-101.2	-98.2	-96.5	-93.5	-91.7	-90.5	FDD
26	-102.7	-99.7	-97.5 ⁶	-94.5 ⁶	-92.7 ⁶		FDD
27	-103.2	-100.2	-98	-95			FDD
28		-100.2	-98.5	-95.5	-93.7	-91	FDD
30			-99	-96			FDD
31	-99.0	-95.7	-93.5				FDD
...							
33			-100	-97	-95.2	-94	TDD
34			-100	-97	-95.2		TDD
35	-106.2	-102.2	-100	-97	-95.2	-94	TDD
36	-106.2	-102.2	-100	-97	-95.2	-94	TDD
37			-100	-97	-95.2	-94	TDD
38			-100	-97	-95.2	-94	TDD
39			-100	-97	-95.2	-94	TDD
40			-100	-97	-95.2	-94	TDD
41			-98	-95	-93.2	-92	TDD
42			-99	-96	-94.2	-93	TDD
43			-99	-96	-94.2	-93	TDD
44		[-100.2]	[-98]	[-95]	[-93.2]	[-92]	TDD
NOTE 1: The transmitter shall be set to P_{UMAX} as defined in subclause 6.2.5							
NOTE 2: Reference measurement channel is A.3.2 with one sided dynamic OCNG Pattern OP.1 FDD/TDD as described in Annex A.5.1.1/A.5.2.1							
NOTE 3: The signal power is specified per port							
NOTE 4: For the UE which supports both Band 3 and Band 9 the reference sensitivity level is FFS.							
NOTE 5: For the UE which supports both Band 11 and Band 21 the reference sensitivity level is FFS.							
NOTE 6: ⁶ indicates that the requirement is modified by -0.5 dB when the carrier							

NOTE 7: frequency of the assigned E-UTRA channel bandwidth is within 865-894 MHz. For a UE that support both Band 18 and Band 26, the reference sensitivity level for Band 26 applies for the applicable channel bandwidths.
--

The reference receive sensitivity (REFSENS) requirement specified in Table 7.3.1-1 shall be met for an uplink transmission bandwidth less than or equal to that specified in Table 7.3.1-2.

NOTE: Table 7.3.1-2 is intended for conformance tests and does not necessarily reflect the operational conditions of the network, where the number of uplink and downlink allocated resource blocks will be practically constrained by other factors. Typical receiver sensitivity performance with HARQ retransmission enabled and using a residual BLER metric relevant for e.g. Speech Services is given in the Annex G (informative).

For the UE which supports inter-band carrier aggregation configuration in Table 7.3.1-1A and Table 7.3.1-1B with the uplink in one or two E-UTRA bands, the minimum requirement for reference sensitivity in Table 7.3.1-1 shall be increased by the amount given in $\Delta R_{IB,c}$ in Table 7.3.1-1A and Table 7.3.1-1B for the applicable E-UTRA bands.

Table 7.3.1-1A: $\Delta R_{IB,c}$ (two bands)

Inter-band CA Configuration	E-UTRA Band	$\Delta R_{IB,c}$ [dB]
CA_1A-3A	1	0
	3	0
CA_1A-5A	1	0
	5	0
CA_1A-7A	1	0
	7	0
CA_1A-8A	1	0
	8	0
CA_1A-11A	1	0
	11	0
CA_1A-18A	1	0
	18	0
CA_1A-19A	1	0
	19	0
CA_1A-20A	1	0
	20	0
CA_1A-21A	1	0
	21	0
CA_1A-26A	1	0
	26	0
CA_1A-28A	1	0
	28	0.2
CA_1A-41A ⁸	1	0
	41	0
CA_1A-41C ⁸	1	0
	41	0
CA_1A-42A	1	0
	42	0.5
CA_1A-42C	1	0
	42	0.5
CA_2A-4A	2	0.3
	4	0.3
CA_2A-4A-4A	2	0.3
	4	0.3
CA_2A-5A	2	0
	5	0
CA_2A-2A-5A	2	0
	5	0
CA_2A-12A	2	0
	12	0
CA_2A-12B	2	0
	12	0
CA_2A-13A	2	0
	13	0
CA_2A-2A-13A	2	0
	13	0
CA_2A-17A	2	0
	17	0.5
CA_2A-29A	2	0
CA_2C-29A	2	0
CA_2A-30A	2	0.4
	30	0.5
CA_3A-5A	3	0
	5	0
CA_3A-7A	3	0
	7	0
CA_3A-7C	3	0
	7	0
CA_3C-7A	3	0
	7	0
CA_3A-8A	3	0

	8	0
CA_3A-19A	3	0
	19	0
CA_3A-20A	3	0
	20	0
CA_3A-26A	3	0
	26	0
CA_3A-27A	3	0
	27	0
CA_3A-28A	3	0
	28	0
CA_3A-42A	3	0.2
	42	0.5
CA_3A-42C	3	0.2
	42	0.5
CA_4A-5A	4	0
	5	0
CA_4A-4A-5A	4	0
	5	0
CA_4A-7A	4	0.5
	7	0.5
CA_4A-4A-7A	4	0.5
	7	0.5
CA_4A-12A	4	0
	12	0.5
CA_4A-12B	4	0
	12	0.5
CA_4A-4A-12A	4	0
	12	0.5
CA_4A-13A	4	0
	13	0
CA_4A-4A-13A	4	0
	13	0
CA_4A-17A	4	0
	17	0.5
CA_4A-27A	4	0
	27	0
CA_4A-29A	4	0
	4	0
CA_4A-30A	4	0.4
	30	0.5
CA_5A-7A	5	0
	7	0
CA_5A-12A	5	0.5
	12	0.3
CA_5A-13A	5	0
	13	0
CA_5A-17A	5	0.5
	17	0.3
CA_5A-25A	5	0
	25	0
CA_5A-30A	5	0
	30	0
CA_7A-8A	7	0
	8	0.2
CA_7A-12A	7	0
	12	0
CA_7A-20A	7	0
	20	0
CA_7A-28A	7	0
	28	0
CA_8A-11A	8	0
	11	0
CA_8A-20A	8	0
	20	0
CA_8A-40A	8	0

	40	0
CA_11A-18A	11	0
	18	0
CA_12A-25A	12	0
	25	0
CA_12A-30A	12	0
	30	0
CA_18A-28A ⁹	18	0
	28	0
CA_19A-21A	19	0
	21	0
CA_19A-42A	19	0
	42	0.5
CA_19A-42C	19	0
	42	0.5
CA_20A-32A	20	0
CA_23A-29A	23	0
CA_25A-41A ⁸	25	0
	41	0
CA_25A-41C ⁸	25	0
	41	0
CA_26A-41A	26	0
	41	0
CA_26A-41C	26	0
	41	0
CA_29A-30A	30	0
CA_39A-41A	39	0.2 ⁴
	41	0.2 ⁴
CA_39A-41A	39	0.2 ⁷
	41	0.2 ⁷
CA_39A-41C	39	0.2 ⁴
	41	0.2 ⁴
CA_39C-41A	39	0.2 ⁴
	41	0.2 ⁴
CA_41A-42A	41	0.4 ⁴
	42	0.5 ⁴
NOTE 1: The above additional tolerances are only applicable for the E-UTRA operating bands that belong to the supported inter-band carrier aggregation configurations		
NOTE 2: The above additional tolerances also apply in intra-band and non-aggregated operation for the supported E-UTRA operating bands that belong to the supported inter-band carrier aggregation configurations		
NOTE 3: In case the UE supports more than one of the above 2DL inter-band carrier aggregation configurations and a E-UTRA operating band belongs to more than one 2DL inter-band carrier aggregation configurations then:		
- When the E-UTRA operating band frequency range is ≤ 1 GHz, the applicable additional tolerance shall be the average of the 2DL tolerances in Table 7.3.1-1A, truncated to one decimal place that would apply for that operating band among the supported 2DL CA configurations. In case there is a harmonic relation between low band UL and high band DL, then the maximum tolerance among the different supported 2DL carrier aggregation configurations involving such band shall be applied		
- When the E-UTRA operating band frequency range is > 1 GHz, the applicable additional tolerance shall be the maximum 2DL tolerance in Table 7.3.1-1A that would apply for that operating band among the supported 2DL CA configurations		
NOTE 4: Only applicable for UE supporting inter-band carrier aggregation with uplink in one E-UTRA band and without simultaneous Rx/Tx.		
NOTE 5: Unless otherwise specified, in case the UE supports more than one of the above 3DL inter-band carrier aggregation configurations and a E-UTRA operating band belongs to more than one 3DL inter-band carrier aggregation configurations then:		
- When the E-UTRA operating band frequency range is ≤ 1 GHz and the tolerances are the same, the value applies to the band. If the tolerances		

are different, the applicable additional 3DL tolerance is FFS. In case there is a harmonic relation between low band UL and high band DL, then the maximum tolerance among the different supported 3DL carrier aggregation configurations involving such band shall be applied

- When the E-UTRA operating band frequency range is >1GHz, the applicable additional 3DL tolerance shall be the maximum tolerance above that applies for that operating band among the supported 3DL CA configurations

NOTE 6: The above additional tolerances applicable for the E-UTRA operating bands that belong to the supported highest order inter-band carrier aggregation configuration, also applies to the same E-UTRA operating bands that belong to a supported lower order CA configuration.

NOTE 7: Applicable for UE supporting inter-band carrier aggregation with two uplinks and without simultaneous Rx/Tx.

NOTE 8: Only applicable for UE supporting inter-band carrier aggregation with the uplink active in the FDD band.

NOTE 9: For Band 28, the requirements only apply for the restricted frequency range specified for this CA configuration (Table 5.5A-2).

Table 7.3.1-1B: $\Delta R_{IB,c}$ (three bands)

Inter-band CA Configuration	E-UTRA Band	$\Delta R_{IB,c}$ [dB]
CA_1A-3A-5A	1	0
	3	0
	5	0
CA_1A-3A-8A	1	0
	3	0
	8	0
CA_1A-3A-19A	1	0
	3	0
	19	0
CA_1A-3A-20A	1	0
	3	0
	20	0
CA_1A-3A-26A	1	0
	3	0
	26	0
CA_1A-5A-7A	1	0
	5	0
	7	0
CA_1A-7A-20A	1	0
	7	0
	20	0
CA_1A-18A-28A	1	0
	18	0
	28	0
CA_1A-19A-21A	1	0
	19	0
	21	0
CA_2A-4A-5A	2	0.3
	4	0.3
	5	0
CA_2A-4A-12A	2	0.3
	4	0.3
	12	0.5
CA_2A-4A-13A	2	0.3
	4	0.3
	13	0
CA_2A-4A-29A	2	0.3
	4	0.3
CA_2A-5A-12A	2	0
	5	0.5
	12	0.3
CA_2A-5A-13A	2	0
	5	0
	13	0
CA_2A-5A-30A	2	0.4
	5	0
	30	0.5
CA_2A-12A-30A	2	0.4
	12	0
	30	0.5
CA_2A-29A-30A	2	0.4
	30	0.5
CA_3A-7A-20A	3	0
	7	0
	20	0
CA_4A-5A-12A	4	0
	5	0.5
	12	0.5
CA_4A-5A-13A	4	0
	5	0
	13	0

CA_4A-5A-30A	4	0.4
	5	0
	30	0.5
CA_4A-7A-12A	4	0.5
	7	0.5
	12	0.5
CA_4A-12A-30A	4	0.4
	12	0.5
	30	0.5
CA_4A-29A-30A	4	0.4
	30	0.5
CA_7A-8A-20A	7	0
	8	0.2
	20	[0.2]
<p>NOTE 1: The above additional tolerances are only applicable for the E-UTRA operating bands that belong to the supported inter-band carrier aggregation configurations.</p> <p>NOTE 2: The above additional tolerances also apply in intra-band and non-aggregated operation for the supported E-UTRA operating bands that belong to the supported inter-band carrier aggregation configurations.</p> <p>NOTE 3: Unless otherwise specified, in case the UE supports more than one of the above 3DL inter-band carrier aggregation configurations and a E-UTRA operating band belongs to more than one 3DL inter-band carrier aggregation configurations then:</p> <ul style="list-style-type: none"> - When the E-UTRA operating band frequency range is ≤ 1GHz and the tolerances are the same, the value applies to the band. If the tolerances are different, the applicable additional 3DL tolerance is FFS. In case there is a harmonic relation between low band UL and high band DL, then the maximum tolerance among the different supported 3DL carrier aggregation configurations involving such band shall be applied - When the E-UTRA operating band frequency range is >1GHz, the applicable additional 3DL tolerance shall be the maximum tolerance above that applies for that operating band among the supported 3DL CA configurations <p>NOTE 4: The above additional tolerances applicable for the E-UTRA operating bands that belong to the supported highest order inter-band carrier aggregation configuration, also applies to the same E-UTRA operating bands that belong to a supported lower order CA configuration.</p>		

NOTE : The above additional tolerances do not apply to supported UTRA operating bands with frequency range below 1 GHz that correspond to the E-UTRA operating bands that belong to the supported inter-band carrier aggregation configurations when such bands are belonging only to band combination(s) where one band is <1 GHz and other bands are >1.7 GHz and there is no harmonic relationship between the low band UL and high band DL. Otherwise the above additional tolerances also apply to supported UTRA operating bands that correspond to the E-UTRA operating bands that belong to the supported inter-band carrier aggregation configurations.

Table 7.3.1-2: Uplink configuration for reference sensitivity

E-UTRA Band / Channel bandwidth / N _{RB} / Duplex mode							
E-UTRA Band	1.4 MHz	3 MHz	5 MHz	10 MHz	15 MHz	20 MHz	Duplex Mode
1			25	50	75	100	FDD
2	6	15	25	50	50 ¹	50 ¹	FDD
3	6	15	25	50	50 ¹	50 ¹	FDD
4	6	15	25	50	75	100	FDD
5	6	15	25	25 ¹			FDD
6			25	25 ¹			FDD
7			25	50	75	75 ¹	FDD
8	6	15	25	25 ¹			FDD
9			25	50	50 ¹	50 ¹	FDD
10			25	50	75	100	FDD
11			25	25 ¹			FDD
12	6	15	20 ¹	20 ¹			FDD
13			20 ¹	20 ¹			FDD
14			15 ¹	15 ¹			FDD
...							
17			20 ¹	20 ¹			FDD
18			25	25 ¹	25 ¹		FDD
19			25	25 ¹	25 ¹		FDD
20			25	20 ¹	20 ³	20 ³	FDD
21			25	25 ¹	25 ¹		FDD
22			25	50	50 ¹	50 ¹	FDD
23	6	15	25	50	75	100	FDD
24			25	50			FDD
25	6	15	25	50	50 ¹	50 ¹	FDD
26	6	15	25	25 ¹	25 ¹		FDD
27	6	15	25	25 ¹			FDD
28		15	25	25 ¹	25 ¹	25 ¹	FDD
30			25	25 ¹			FDD
31	6	5 ⁴	5 ⁴				FDD
...							
33			25	50	75	100	TDD
34			25	50	75		TDD
35	6	15	25	50	75	100	TDD
36	6	15	25	50	75	100	TDD
37			25	50	75	100	TDD
38			25	50	75	100	TDD
39			25	50	75	100	TDD
40			25	50	75	100	TDD
41			25	50	75	100	TDD
42			25	50	75	100	TDD
43			25	50	75	100	TDD
44		15	25	50	75	100	TDD
NOTE 1: ¹ refers to the UL resource blocks shall be located as close as possible to the downlink operating band but confined within the transmission bandwidth configuration for the channel bandwidth (Table 5.6-1).							
NOTE 2: For the UE which supports both Band 11 and Band 21 the uplink configuration for reference sensitivity is FFS.							
NOTE 3: ³ refers to Band 20; in the case of 15MHz channel bandwidth, the UL resource blocks shall be located at RB _{start} 11 and in the case of 20MHz channel bandwidth, the UL resource blocks shall be located at RB _{start} 16							
NOTE 4: ⁴ refers to Band 31; in the case of 3 MHz channel bandwidth, the UL							

resource blocks shall be located at RB_{start} 9 and in the case of 5 MHz channel bandwidth, the UL resource blocks shall be located at RB_{start} 10.

Unless given by Table 7.3.1-3, the minimum requirements specified in Tables 7.3.1-1 and 7.3.1-2 shall be verified with the network signalling value NS_01 (Table 6.2.4-1) configured.

Table 7.3.1-3: Network signalling value for reference sensitivity

E-UTRA Band	Network Signalling value
2	NS_03
4	NS_03
10	NS_03
12	NS_06
13	NS_06
14	NS_06
17	NS_06
19	NS_08
21	NS_09
23	NS_03
25	NS_03
30	NS_21

7.3.1A Minimum requirements (QPSK) for CA

For inter-band carrier aggregation with one component carrier per operating band and the uplink assigned to one E-UTRA band the throughput shall be $\geq 95\%$ of the maximum throughput of the reference measurement channels as specified in Annexes A.2.2, A.2.3 and A.3.2 (with one sided dynamic OCN Pattern OP.1 FDD/TDD for the DL-signal as described in Annex A.5.1.1/A.5.2.1) with parameters specified in Table 7.3.1-1 and Table 7.3.1-2. The reference sensitivity is defined to be met with all downlink component carriers active and one of the uplink carriers active. The uplink resource blocks shall be located as close as possible to the primary downlink operating band but confined within the transmission bandwidth configuration for the channel bandwidth (Table 5.6-1). The primary downlink operating band is the downlink band of the active uplink operating band. The UE shall meet the requirements specified in subclause 7.3.1 with the following exceptions.

For the UE that supports any of the E-UTRA CA configurations given in Table 7.3.1A-0a, exceptions to the aforementioned requirements are allowed when the uplink is active in a lower-frequency band and is within a specified frequency range such that transmitter harmonics fall within the downlink transmission bandwidth assigned in a higher band as noted in Table 7.3.1A-0a. For these exceptions, the UE shall meet the requirements specified in Table 7.3.1A-0a and Table 7.3.1A-0b.

Table 7.3.1A-0a: Reference sensitivity for carrier aggregation QPSK $P_{REFSENS, CA}$ (exceptions due to harmonic issue)

Channel bandwidth								
EUTRA CA Configuration	EUTRA band	1.4 MHz (dBm)	3 MHz (dBm)	5 MHz (dBm)	10 MHz (dBm)	15 MHz (dBm)	20 MHz (dBm)	Duplex mode
CA_1A-3A-8A ⁴	1			N/A	N/A	N/A	N/A	FDD
	3			N/A	N/A	N/A	N/A	
	8		N/A	N/A	N/A			
CA_1A-18A-28A ¹²	1			N/A	N/A	N/A	N/A	FDD
	18			N/A	N/A	N/A		
	28			N/A	N/A			
CA_1A-28A ^{5,6}	1			-89.8	-89.4	-89	-88.7	FDD
	28			-98.3	-95.3	-93.5	-90.8	
CA_3A-8A ⁴	3			N/A	N/A	N/A	N/A	FDD
	8		N/A	N/A	N/A			
CA_3A-42A ^{9,10}	3			-96.8	-93.8	-92	-90.8	FDD
	42			-71.7	-71.7	-71.7	-71.7	TDD
CA_3A-42A ¹¹	3			-96.8	-93.8	-92	-90.8	FDD
	42			-97.1	-94.7	-93.2	-92.5	TDD
CA_4A-12A ^{5,6}	4	-89.2	-89.2	-90	-89.5	-89	-88.5	FDD
	12		-98.2	-96.5	-93.5			
CA_4A-17A ^{5,6}	4			-90	-89.5			FDD
	17			-96.5	-93.5			
CA_2A-4A-12A ^{5,6}	2			-97.7	-94.7	-92.9	-91.7	FDD
	4			-90	-89.5	-89	-88.5	
	12			-96.5	-93.5			
CA_4A-5A-12A ^{5,6}	4			-90	-89.5	-89	-88.5	FDD
	5			-97.5	-94.5			
	12			-96.5	-93.5			
CA_4A-7A-12A ^{5,6}	4			-90	-89.5	-89	-88.5	FDD
	7			-97.5	-94.5			
	12			-96.5	-93.5			
CA_26A-41A ⁸	26			N/A	N/A	N/A	N/A	FDD
	41			N/A	N/A	N/A	N/A	TDD
CA_7A-8A ^{5,6}	7				-87.4	-87	-86.7	FDD
	8		-99	-96.8	-93.8			
CA_7A-8A-20A ^{5,6}	7				-87.4	-87	-86.7	FDD
	8		-99	-96.8	-93.8			
	20			[-96.8]	[-93.8]			

NOTE 1: The transmitter shall be set to P_{UMAX} as defined in subclause 6.2.5A.

NOTE 2: Reference measurement channel is A.3.2 with one sided dynamic OCNG Pattern OP.1 FDD/TDD as described in Annex A.5.1.1/A.5.2.1

NOTE 3: The signal power is specified per port

NOTE 4: No requirements apply when there is at least one individual RE within the uplink transmission bandwidth of the low band for which the 2nd transmitter harmonic is within the downlink transmission bandwidth of the high band. The reference sensitivity is only verified when this is not the case (the requirements specified in clause 7.3.1 apply).

NOTE 5: These requirements apply when there is at least one individual RE within the uplink transmission bandwidth of a low band for which the 3rd transmitter harmonic is within the downlink transmission bandwidth of a high band.

NOTE 6: The requirements should be verified for UL EARFCN of a low band (superscript LB) such that $f_{UL}^{LB} = \lfloor f_{DL}^{HB} / 0.3 \rfloor 0.1$ in MHz and $F_{UL_low}^{LB} + BW_{Channel}^{LB} / 2 \leq f_{UL}^{LB} \leq F_{UL_high}^{LB} - BW_{Channel}^{LB} / 2$ with f_{DL}^{HB} the carrier frequency of a high band in MHz and $BW_{Channel}^{LB}$ the channel bandwidth configured in the low band.

NOTE 7: Void.

NOTE 8: No requirements apply when there is at least one individual RE within the uplink transmission bandwidth of the low band for which the 3rd transmitter harmonic is within the downlink transmission bandwidth of the high band. The reference sensitivity is only verified when this is not the case (the requirements specified in clause 7.3.1 apply).

NOTE 9: These requirements apply when there is at least one individual RE within the uplink transmission bandwidth of the aggressor (lower) band for which the 2nd transmitter harmonic

is within the downlink transmission bandwidth of a victim (higher) band and a range ΔF_{HD} above and below the edge of this downlink transmission bandwidth. The value ΔF_{HD} depends on the E-UTRA configuration: $\Delta F_{HD} = 10$ MHz for CA_3A-42A.

NOTE 10: The requirements should be verified for UL EARFCN of the aggressor (lower) band (superscript LB) such that $f_{UL}^{LB} = \lfloor f_{DL}^{HB} / 0.2 \rfloor \cdot 0.1$ in MHz and

$$F_{UL_low}^{LB} + BW_{Channel}^{LB} / 2 \leq f_{UL}^{LB} \leq F_{UL_high}^{LB} - BW_{Channel}^{LB} / 2$$

with f_{DL}^{HB} carrier frequency in the victim (higher) band in MHz and $BW_{Channel}^{LB}$ the channel bandwidth configured in the lower band.

NOTE 11: The requirements are only applicable to channel bandwidths with a carrier frequency at $\pm (20 + BW_{Channel}^{HB} / 2)$ MHz offset from $2f_{UL}^{LB}$ in the victim (higher) band with

$$F_{UL_low}^{LB} + BW_{Channel}^{LB} / 2 \leq f_{UL}^{LB} \leq F_{UL_high}^{LB} - BW_{Channel}^{LB} / 2$$

where $BW_{Channel}^{LB}$ and $BW_{Channel}^{HB}$ are the channel bandwidths configured in the aggressor (lower) and victim (higher) bands in MHz, respectively.

NOTE 12: For the UE that supports CA_1A-18A-28A, no requirements apply when there is at least one individual RE within the uplink transmission bandwidth of the low band for which the 3rd transmitter harmonic is within the downlink transmission bandwidth of the high band. The reference sensitivity should only be verified when this is not the case (the requirements specified in clause 7.3.1 apply).

Table 7.3.1A-0b: Uplink configuration for the low band (exceptions due to harmonic issue)

E-UTRA Band / Channel bandwidth of the high band / N _{RB} / Duplex mode								
EUTRA CA Configuration	UL band	1.4 MHz	3 MHz	5 MHz	10 MHz	15 MHz	20 MHz	Duplex mode
CA_1A-28A	28			8	16	25	25	FDD
CA_4A-12A	12	2	5	8	16	20	20	FDD
CA_4A-17A	17			8	16			FDD
CA_2A-4A-12A	12			8	16	20	20	FDD
CA_3A-42A	3			12	25	36	50	FDD
CA_4A-5A-12A	12			8	16	20	20	FDD
CA_4A-7A-12A	12			8	16	20	20	FDD
CA_7A-8A	8				16	25	25	FDD
CA_7A-8A-20A	8				16	25	25	FDD

NOTE 1: refers to the UL resource blocks, which shall be centred within the transmission bandwidth configuration for the channel bandwidth.

NOTE 2: the UL configuration applies regardless of the channel bandwidth of the low band unless the UL resource blocks exceed that specified in Table 7.3.1-2 for the uplink bandwidth in which case the allocation according to Table 7.3.1-2 applies.

For the UE that supports any of the E-UTRA CA configurations given in Table 7.3.1A-0bA, exceptions are allowed when the uplink is active within a specified frequency range as noted in Table 7.3.1A-0bA. For these exceptions, the UE shall meet the requirements specified in Table 7.3.1A-0bA and Table 7.3.1A-0bB.

Table 7.3.1A-0bA: Reference sensitivity for carrier aggregation QPSK $P_{REFSENS, CA}$ (exceptions for two bands due to close proximity of UL to DL channel)

Channel bandwidth								
EUTRA CA Configuration	EUTRA band	1.4 MHz (dBm)	3 MHz (dBm)	5 MHz (dBm)	10 MHz (dBm)	15 MHz (dBm)	20 MHz (dBm)	Duplex mode
CA_1A-3A ⁴	1			-100	-97	-95.2	-94	FDD
	3			-94	-91.5	-90	-89	
CA_1A-3A ⁵	1			-100	-97	-95.2	-94	FDD
	3			-97	-94	-92.2	-91	
CA_18A-28A ⁶	18			-100	-97	-95.2		FDD
	28			-94	-92.5			

NOTE 1: The transmitter shall be set to P_{UMAX} as defined in subclause 6.2.5A.
NOTE 2: Reference measurement channel is A.3.2 with one sided dynamic OCNG Pattern OP.1 FDD/TDD as described in Annex A.5.1.1/A.5.2.1
NOTE 3: The signal power is specified per port
NOTE 4: These requirements apply when the uplink is active in Band 1 and the separation between the lower edge of the uplink channel in Band 1 and the upper edge of the downlink channel in Band 3 is < 60 MHz. For each channel bandwidth in Band 3, the requirement applies regardless of channel bandwidth in Band 1.
NOTE 5: These requirements apply when the uplink is active in Band 1 and the separation between the lower edge of the uplink channel in Band 1 and the upper edge of the downlink channel in Band 3 is \geq 60 MHz. For each channel bandwidth in Band 3, the requirement applies regardless of channel bandwidth in Band 1.
NOTE 6: These requirements apply when the uplink is active in Band 18 and the downlink channels in Band 28 are confined within the restricted frequency range specified for this CA configuration (Table 5.5A-2). For each channel bandwidth in Band 28, the requirement applies regardless of channel bandwidth in Band 18.

Table 7.3.1A-0bB: Uplink configuration for the uplink band (exceptions for two bands due to close proximity of UL to DL channel)

E-UTRA Band / Channel bandwidth of the affected DL band / N_{RB} / Duplex mode								
EUTRA CA Configuration	UL band	1.4 MHz	3 MHz	5 MHz	10 MHz	15 MHz	20 MHz	Duplex mode
CA_1A-3A ^{1,2}	1			25	25	25	25	FDD
CA_1A-3A ^{1,3}	1			25	45	45	45	FDD
CA_18A-28A ⁴	18			18	18			FDD

NOTE 1: refers to the UL resource blocks shall be located as close as possible to the downlink channel in Band 3 but confined within the transmission bandwidth configuration for the channel bandwidth (Table 5.6-1) in the uplink channel in Band 1.
NOTE 2: UL allocation when the separation between the lower edge of the uplink channel in Band 1 and the upper edge of the downlink channel in Band 3 is < 60 MHz
NOTE 3: UL allocation when the separation between the lower edge of the uplink channel in Band 1 and the upper edge of the downlink channel in Band 3 is \geq 60 MHz.
NOTE 4: refers to the UL resource blocks shall be located as close as possible to the downlink channel in Band 28 but confined within the transmission bandwidth configuration for the channel bandwidth (Table 5.6-1).

For the UE that supports any of the E-UTRA CA configurations given in Table 7.3.1A-0bC, exceptions are allowed when the uplink is active within a specified frequency range as noted in Table 7.3.1A-0bC. For these exceptions, the UE shall meet the requirements specified in Table 7.3.1A-0bC and Table 7.3.1A-0bD.

Table 7.3.1A-0bC: Reference sensitivity for carrier aggregation QPSK $P_{\text{REFSENS, CA}}$ (exceptions for three bands due to close proximity of UL to DL channel)

Channel bandwidth								
EUTRA CA Configuration	EUTRA band	1.4 MHz (dBm)	3 MHz (dBm)	5 MHz (dBm)	10 MHz (dBm)	15 MHz (dBm)	20 MHz (dBm)	Duplex mode
CA_1A-3A-5A ⁴	1			-100	-97	-95.2	-94	FDD
	3			-94	-91.5	-90	-89	
	5			-98	-95			
CA_1A-3A-5A ⁵	1			-100	-97	-95.2	-94	FDD
	3			-97	-94	-92.2	-91	
	5			-98	-95			
CA_1A-3A-8A ⁴	1			-100	-97	-95.2	-94	FDD
	3			-94	-91.5	-90	-89	
	8		-99.2	-97	-94			
CA_1A-3A-8A ⁵	1			-100	-97	-95.2	-94	FDD
	3			-97	-94	-92.2	-91	
	8		-99.2	-97	-94			
CA_1A-3A-19A ⁴	1			-100	-97	-95.2	-94	FDD
	3			-94	-91.5	-90	-89	
	19			-100	-97	-95.2		
CA_1A-3A-19A ⁵	1			-100	-97	-95.2	-94	FDD
	3			-97	-94	-92.2	-91	
	19			-100	-97	-95.2		
CA_1A-3A-20A ⁴	1			-100	-97	-95.2	-94	FDD
	3			-94	-91.5	-90	-89	
	20			-97	-94	-91.2	-90	
CA_1A-3A-20A ⁵	1			-100	-97	-95.2	-94	FDD
	3			-97	-94	-92.2	-91	
	20			-97	-94	-91.2	-90	
CA_1A-3A-26A ⁴	1			-100	-97	-95.2	-94	FDD
	3			-94	-91.5	-90	-89	
	26			-97.5 ⁷	-94.5 ⁷			
CA_1A-3A-26A ⁵	1			-100	-97	-95.2	-94	FDD
	3			-97	-94	-92.2	-91	
	26			-97.5 ⁷	-94.5 ⁷			
CA_1A-18A-28A ⁶	1			-100	-97	-95.2	-94	FDD
	18			-100	-97	-95.2		
	28			-94	-92.5			

NOTE 1: The transmitter shall be set to P_{UMAX} as defined in subclause 6.2.5A.

NOTE 2: Reference measurement channel is A.3.2 with one sided dynamic OCNG Pattern OP.1 FDD/TDD as described in Annex A.5.1.1/A.5.2.1

NOTE 3: The signal power is specified per port

NOTE 4: These requirements apply when the uplink is active in Band 1 and the separation between the lower edge of the uplink channel in Band 1 and the upper edge of the downlink channel in Band 3 is < 60 MHz. For each channel bandwidth in Band 3 and Band 5 or Band 8 or Band 19 or Band 20 or Band 26, the requirement applies regardless of channel bandwidth in Band 1.

NOTE 5: These requirements apply when the uplink is active in Band 1 and the separation between the lower edge of the uplink channel in Band 1 and the upper edge of the downlink channel in Band 3 is \geq 60 MHz. For each channel bandwidth in Band 3 and Band 5 or Band 8 or Band 19 or Band 20 or Band 26, the requirement applies regardless of channel bandwidth in Band 1.

NOTE 6: These requirements apply when the uplink is active in Band 18 and the downlink channels in Band 28 are confined within the restricted frequency range specified for this CA configuration (Table 5.5A-2). For each channel bandwidth in Band 28, the requirement applies regardless of channel bandwidth in Band 18.

NOTE 7: ⁷ indicates that the requirement is modified by -0.5 dB when the carrier frequency of the assigned E-UTRA channel bandwidth is within 865-894 MHz.

Table 7.3.1A-0bD: Uplink configuration for the uplink band (exceptions for three bands due to close proximity of UL to DL channel)

E-UTRA Band / Channel bandwidth of the affected DL band / N _{RB} / Duplex mode								
EUTRA CA Configuration	UL band	1.4 MHz	3 MHz	5 MHz	10 MHz	15 MHz	20 MHz	Duplex mode
CA_1A-3A-5A ^{1,2}	1			25	25	25	25	FDD
CA_1A-3A-5A ^{1,3}	1			25	45	45	45	FDD
CA_1A-3A-8A ^{1,2}	1			25	25	25	25	FDD
CA_1A-3A-8A ^{1,3}	1			25	45	45	45	FDD
CA_1A-3A-19A ^{1,2}	1			25	25	25	25	FDD
CA_1A-3A-19A ^{1,3}	1			25	45	45	45	FDD
CA_1A-3A-20A ^{1,2}	1			25	25	25	25	FDD
CA_1A-3A-20A ^{1,3}	1			25	45	45	45	FDD
CA_1A-3A-26A ^{1,2}	1			25	25	25	25	FDD
CA_1A-3A-26A ^{1,3}	1			25	45	45	45	FDD
CA_1A-18A-28A ⁴	18			18	18			FDD
<p>NOTE 1: refers to the UL resource blocks shall be located as close as possible to the downlink channel in Band 3 but confined within the transmission bandwidth configuration for the channel bandwidth (Table 5.6-1) in the uplink channel in Band 1.</p> <p>NOTE 2: UL allocation when the separation between the lower edge of the uplink channel in Band 1 and the upper edge of the downlink channel in Band 3 is < 60 MHz</p> <p>NOTE 3: UL allocation when the separation between the lower edge of the uplink channel in Band 1 and the upper edge of the downlink channel in Band 3 is ≥ 60 MHz.</p> <p>NOTE 4: refers to the UL resource blocks shall be located as close as possible to the downlink channel in Band 28 but confined within the transmission bandwidth configuration for the channel bandwidth (Table 5.6-1).</p>								

For band combinations including operating bands without uplink band (as noted in Table 5.5-1), the requirements are specified in Table 7.3.1A-0d for any uplink band with uplink configuration specified in Table 7.3.1-2.

Table 7.3.1A-0d: Reference sensitivity QPSK P_{REFSENS} (CA with a SDL band)

Channel bandwidth								
EUTRA CA Configuration	EUTRA band	1.4 MHz (dBm)	3 MHz (dBm)	5 MHz (dBm)	10 MHz (dBm)	15 MHz (dBm)	20 MHz (dBm)	Duplex mode
CA_2A-29A	2			-98	-95	-93.2	-92	FDD
	29		-98.7	-97	-94			
CA_2C-29A	2			-98	-95	-93.2	-92	FDD
	29			-97	-94			
CA_4A-29A	4			-100	-97	-95.2	-94	FDD
	29		-98.7	-97	-94			
CA_20A-32A	20			-97	-94			FDD
	32			-100	-97	-95.2	-94	
CA_23A-29A	23			-100	-97	-95.2	-94	FDD
	29		-98.7	-97	-94			
CA_29A-30A	29			-97	-94			FDD
	30			-99	-96			
CA_2A-4A-29A	2			-97.7	-94.7	-92.9	-91.7	FDD
	4			-99.7	-96.7	-94.9	-93.7	
	29			-97	-94			
CA_2A-29A-30A	2			-97.6	-94.6	-92.8	-91.6	FDD
	29			-97	-94			
	30			-98.5	-95.5			
CA_4A-29A-30A	4			-99.6	-96.6	-94.8	-93.6	FDD
	29			-97	-94			
	30			-98.5	-95.5			

NOTE 1: The transmitter shall be set to P_{UMAX} as defined in subclause 6.2.5A.
NOTE 2: Reference measurement channel is A.3.2 with one sided dynamic OCNG Pattern OP.1 FDD/TDD as described in Annex A.5.1.1/A.5.2.1
NOTE 3: The signal power is specified per port

Table 7.3.1A-0e: Void

In all cases for single uplink inter-band CA, unless given by Table 7.3.1-3 for the band with the active uplink carrier, the applicable reference sensitivity requirements shall be verified with the network signalling value NS_01 (Table 6.2.4-1) configured.

For inter-band carrier aggregation with uplink assigned to two E-UTRA bands the throughput shall be $\geq 95\%$ of the maximum throughput of the reference measurement channels as specified in Annexes A.2.2, A.2.3 and A.3.2 (with one sided dynamic OCNG Pattern OP.1 FDD/TDD for the DL-signal as described in Annex A.5.1.1/A.5.2.1) with parameters specified in Table 7.3.1-1 and Table 7.3.1-2. The reference sensitivity is defined to be met with all downlink component carriers active and both of the uplink carriers active.

For E-UTRA CA configurations with uplink and downlink assigned to two E-UTRA bands given in Table 7.3.1A-0f the reference sensitivity is defined only for the specific uplink and downlink test points which are specified in Table 7.3.1A-0f. For these test points the reference sensitivity requirement specified in Table 7.3.1-1 is relaxed by the amount of parameter MSD given in Table 7.3.1A-0f.

The allowed exceptions defined in Table 7.3.1A-0a and Table 7.3.1A-0b for inter-band carrier aggregation with a single active uplink are also applicable for dual uplink operation.

Table 7.3.1A-0f: 2 UL and 2 DL interband reference sensitivity QPSK P_{REFSENS} and uplink/downlink configurations

E-UTRA Band / Channel bandwidth / N_{RB} / Duplex mode							
EUTRA CA Configuration	EUTRA band	UL F_c (MHz)	UL/DL BW (MHz)	UL C_{LRB}	DL F_c (MHz)	MSD (dB)	Duplex mode

CA_1A-3A	1	1950	5	25	2140	23	FDD
	3	1760	5	25	1855	N/A	
CA_1A-8A	1	1965	5	25	2155	6	FDD
	8	887.5	5	25	932.5	N/A	
CA_2A-4A	2	1860	20	50 ²	1940	5	FDD
	4	1752.5	5	25	2152.5	N/A	
CA_2A-4A	2	1868.3	5	25	1948.3	N/A	FDD
	4	1735	5	25	2135	5	
CA_3A-5A	3	1771	10	50	1866	4	FDD
	5	838	5	25	883	N/A	
CA_3A-5A	3	1721	10	50	1816	N/A	FDD
	5	838	5	25	883	24	
CA_3A-7A	3	1730	5	25	1825	N/A	FDD
	7	2535	10	50	2655	13	
CA_3A-8A	3	1755	10	50	1850	N/A	FDD
	8	900	5	25	945	8	
CA_3A-8A	3	1747.5	10	50	1842.5	6.4	FDD
	8	897.5	5	25	942.5	N/A	
CA_3A-19A	3	1771	5	25	1866	4	FDD
	19	838	5	25	883	N/A	
CA_3A-19A	3	1721	5	25	1816	N/A	FDD
	19	838	5	25	883	27	
CA-3A-20A	3	1775	5	25	1870	4	FDD
	20	840	5	25	799	N/A	
CA-3A-20A	3	1735	5	25	1830	N/A	FDD
	20	847	5	25	806	9	
CA_3A-26A	3	1771	5	25	1866	4	FDD
	26	838	5	25	883	N/A	
CA_3A-26A	3	1721	5	25	1816	N/A	FDD
	26	838	5	25	883	26	
CA_4A-7A	4	1730	5	25	2130	N/A	FDD
	7	2535	5	25	2655	15	
CA_5A-7A	5	834	5	25	879	12	FDD
	7	2547	10	50	2667	N/A	
CA_7A-20A	7	2512	10	50	2632	N/A	FDD
	20	851	5	25	810	12	
NOTE 1: Both of the transmitters shall be set min(+20 dBm, P _{CMAX_L,c}) as defined in subclause 6.2.5A							
NOTE 2: RB _{START} = 0							

For intra-band contiguous carrier aggregation the throughput of each component carrier shall be $\geq 95\%$ of the maximum throughput of the reference measurement channels as specified in Annexes A.2.2, A.2.3 and A.3.2 (with one sided dynamic OCNG Pattern OP.1 FDD/TDD for the DL-signal as described in Annex A.5.1.1/A.5.2.1) with parameters specified in Table 7.3.1-1 and Table 7.3.1A-1. The requirement is verified using an uplink CA configuration with the largest number of carriers supported by the UE. Table 7.3.1A-1 specifies the maximum number of allocated uplink resource blocks for which the intra-band contiguous carrier aggregation reference sensitivity requirement shall be met. The PCC and SCC allocations as defined in Table 7.3.1A-1 form a contiguous allocation where TX–RX frequency separations of the component carriers are as defined in Table 5.7.4-1. In case downlink CA configuration has additional SCC(s) compared to uplink CA configuration those are configured further away from uplink band. For UE(s) supporting one uplink carrier, the uplink configuration of the PCC shall be in accordance with Table 7.3.1-2 and the downlink PCC carrier center frequency shall be configured closer to uplink operating band than any of the downlink SCC center frequency. Unless given by Table 7.3.1-3, the reference sensitivity requirements shall be verified with the network signalling value NS_01 (Table 6.2.4-1) configured.

Table 7.3.1A-1: Intra-band contiguous CA uplink configuration for reference sensitivity for Bandwidth Class C

Uplink CA configuration	CA configuration / CC combination / N_{RB_agg} / Duplex mode												Duplex Mode
	100RB+25RB		100RB+50RB		75RB+75RB		75RB+50RB		100RB+75RB		100RB+100RB		
	PCC	SCC	PCC	SCC	PCC	SCC	PCC	SCC	PCC	SCC	PCC	SCC	
CA_1C	N/A	N/A	N/A	N/A	75	54	N/A	N/A	N/A	N/A	100	30	FDD
CA_3C	50	0	50	0	N/A	N/A	N/A	N/A	50	0	50	0	FDD
CA_7C	N/A	N/A	75	0	75	0	N/A	N/A	75	0	75	0	FDD
CA_38C	N/A	N/A	N/A	N/A	75	75	N/A	N/A	N/A	N/A	100	100	TDD
CA_39C	100	25	100	50	N/A	N/A	N/A	N/A	100	75	N/A	N/A	TDD
CA_40C	N/A	N/A	100	50	75	75	N/A	N/A	100	75	100	100	TDD
CA_41C	100	25	100	50	75	75	75	50	100	75	100	100	TDD
CA_42C	100	25	100	50	N/A	N/A	N/A	N/A	100	75	100	100	TDD

NOTE 1: The carrier centre frequency of SCC in the UL operating band is configured closer to the DL operating band.
NOTE 2: The transmitted power over both PCC and SCC shall be set to P_{UMAX} as defined in subclause 6.2.5A.
NOTE 3: The UL resource blocks in both PCC and SCC shall be confined within the transmission bandwidth configuration for the channel bandwidth (Table 5.6-1).
NOTE 4: The UL resource blocks in PCC shall be located as close as possible to the downlink operating band, while the UL resource blocks in SCC shall be located as far as possible from the downlink operating band.
NOTE 5: In case a CA configuration consists of CC channel bandwidths which are unequal in bandwidth the PCC channel bandwidth shall be the larger one for reference sensitivity test.
NOTE 6: Void.

For intra-band non-contiguous carrier aggregation with one uplink carrier and two downlink sub-blocks, the throughput of each downlink component carrier shall be $\geq 95\%$ of the maximum throughput of the reference measurement channels as specified in Annexes A.2.2, A.2.3 and A.3.2 (with one sided dynamic OCNG Pattern OP.1 FDD/TDD for the DL-signal as described in Annex A.5.1.1/A.5.2.1) and parameters specified in Table 7.3.1-1 and Table 7.3.1A-3 with the power level in Table 7.3.1-1 increased by ΔR_{IBNC} given in Table 7.3.1A-3 for the SCC(s). The requirements apply with all downlink carriers active. Unless given by Table 7.3.1-3, the reference sensitivity requirements shall be verified with the network signalling value NS_01 (Table 6.2.4-1) configured.

Table 7.3.1A-3: Intra-band non-contiguous CA with one uplink configuration for reference sensitivity

CA configuration	Aggregated channel bandwidth (PCC+SCC)	$W_{\text{gap}} / [\text{MHz}]$	UL PCC allocation	$\Delta R_{\text{IBNC}} (\text{dB})$	Duplex mode
CA_2A-2A	25RB+25RB	$30.0 < W_{\text{gap}} \leq 50.0$	12 ¹	5.3	FDD
		$0.0 < W_{\text{gap}} \leq 30.0$	25 ¹	0	
	25RB+50RB	$25.0 < W_{\text{gap}} \leq 45.0$	12 ¹	4.4	
		$0.0 < W_{\text{gap}} \leq 25.0$	25 ¹	0	
	25RB+75RB	$20.0 < W_{\text{gap}} \leq 40.0$	12 ¹	4.2	
		$0.0 < W_{\text{gap}} \leq 20.0$	25 ¹	0	
	25RB+100RB	$15.0 < W_{\text{gap}} \leq 35.0$	12 ¹	3.8	
		$0.0 < W_{\text{gap}} \leq 15.0$	25 ¹	0	
	50RB+25RB	$15.0 < W_{\text{gap}} \leq 45.0$	12 ¹	5.9	
		$0.0 < W_{\text{gap}} \leq 15.0$	32 ¹	0	
	50RB+50RB	$10.0 < W_{\text{gap}} \leq 40.0$	12 ¹	4.6	
		$0.0 < W_{\text{gap}} \leq 10.0$	32 ¹	0	
	50RB+75RB	$5.0 < W_{\text{gap}} \leq 35.0$	12 ¹	4.1	
		$0.0 < W_{\text{gap}} \leq 5.0$	32 ¹	0	
	50RB+100RB	$0.0 < W_{\text{gap}} \leq 30.0$	12 ¹	4.0	
	75RB+25RB	$10.0 < W_{\text{gap}} \leq 40.0$	12 ¹²	6.7	
		$0.0 < W_{\text{gap}} \leq 10.0$	36 ¹	0	
	75RB+50RB	$5.0 < W_{\text{gap}} \leq 35.0$	12 ¹²	5.4	
		$0.0 < W_{\text{gap}} \leq 5.0$	36 ¹	0	
	75RB+75RB	$0.0 < W_{\text{gap}} \leq 30.0$	12 ¹²	4.6	
75RB+100RB	$0.0 < W_{\text{gap}} \leq 25.0$	12 ¹²	4.2		
100RB+25RB	$0.0 < W_{\text{gap}} \leq 35.0$	16 ¹³	7.2		
100RB+50RB	$0.0 < W_{\text{gap}} \leq 30.0$	16 ¹³	5.8		
100RB+75RB	$0.0 < W_{\text{gap}} \leq 25.0$	16 ¹³	5.0		
100RB+100RB	$0.0 < W_{\text{gap}} \leq 20.0$	16 ¹³	4.6		
CA_3A-3A	25RB+25RB	$45.0 < W_{\text{gap}} \leq 65.0$	12 ¹	4.7	FDD
		$0.0 < W_{\text{gap}} \leq 45.0$	25 ¹	0	
	25RB+50RB	$40.0 < W_{\text{gap}} \leq 60.0$	12 ¹	3.8	
		$0.0 < W_{\text{gap}} \leq 40.0$	25 ¹	0	
	25RB+75RB	$35.0 < W_{\text{gap}} \leq 55.0$	12 ¹	3.6	
		$0.0 < W_{\text{gap}} \leq 35.0$	25 ¹	0	
	25RB+100RB	$30.0 < W_{\text{gap}} \leq 50.0$	12 ¹	3.4	
		$0.0 < W_{\text{gap}} \leq 30.0$	25 ¹	0	
	50RB+25RB	$30.0 < W_{\text{gap}} \leq 60.0$	12 ⁹	5.1	
		$0.0 < W_{\text{gap}} \leq 30.0$	32 ¹	0	
	50RB+50RB	$25.0 < W_{\text{gap}} \leq 55.0$	12 ⁹	4.3	
		$0.0 < W_{\text{gap}} \leq 25.0$	32 ¹	0	
	50RB+75RB	$20.0 < W_{\text{gap}} \leq 50.0$	12 ⁹	3.8	
		$0.0 < W_{\text{gap}} \leq 20.0$	32 ¹	0	
	50RB+100RB	$15.0 < W_{\text{gap}} \leq 45.0$	12 ⁹	3.4	
		$0.0 < W_{\text{gap}} \leq 15.0$	32 ¹	0	
75RB+25RB	$25.0 < W_{\text{gap}} \leq 55.0$	12 ¹⁰	6.0		
	$0.0 < W_{\text{gap}} \leq 25.0$	32 ¹	0		
75RB+50RB	$20.0 < W_{\text{gap}} \leq 50.0$	12 ¹⁰	4.7		
	$0.0 < W_{\text{gap}} \leq 20.0$	32 ¹	0		
75RB+75RB	$15.0 < W_{\text{gap}} \leq 45.0$	12 ¹⁰	4.2		

		$0.0 < W_{gap} \leq 15.0$	32^1	0	
	75RB+100RB	$10.0 < W_{gap} \leq 40.0$	12^{10}	3.8	
		$0.0 < W_{gap} \leq 10.0$	32^1	0	
	100RB+25RB	$15.0 < W_{gap} \leq 50.0$	16^{11}	6.5	
		$0.0 < W_{gap} \leq 15.0$	32^1	0	
	100RB+50RB	$10.0 < W_{gap} \leq 45.0$	16^{11}	5.1	
		$0.0 < W_{gap} \leq 10.0$	32^1	0	
	100RB+75RB	$5.0 < W_{gap} \leq 40.0$	16^{11}	4.5	
		$0.0 < W_{gap} \leq 5.0$	32^1	0	
	100RB+100RB	$0.0 < W_{gap} \leq 35.0$	16^{11}	4.1	
CA_4A-4A	NOTE 6	NOTE 7	NOTE 8	0.0	FDD
CA_7A-7A	50RB+50RB	$25.0 < W_{gap} \leq 50.0$	32^1	0.0	FDD
		$0.0 < W_{gap} \leq 25.0$	50^1	0.0	
	75RB+25RB	$20.0 < W_{gap} \leq 50.0$	32^1	0.0	
		$0.0 < W_{gap} \leq 20.0$	50^1	0.0	
	75RB+50RB	$20.0 < W_{gap} \leq 45.0$	32^1	0.0	
		$0.0 < W_{gap} \leq 20.0$	50^1	0.0	
	75RB+75RB	$15.0 < W_{gap} \leq 40.0$	32^1	0.0	
		$0.0 < W_{gap} \leq 15.0$	50^1	0.0	
	100RB+75RB	$15.0 < W_{gap} \leq 35.0$	36^1	0.0	
		$0.0 < W_{gap} \leq 15.0$	50^1	0.0	
100RB+100RB	$15.0 < W_{gap} \leq 30.0$	32^1	0.0		
	$0.0 < W_{gap} \leq 15.0$	45^1	0.0		
CA_23A-23A	NOTE 6	NOTE 7	NOTE 8	0.0	FDD
CA_25A-25A	25RB+25RB	$30.0 < W_{gap} \leq 55.0$	10^1	5.0	FDD
		$0.0 < W_{gap} \leq 30.0$	25^1	0.0	
	25RB+50RB	$25.0 < W_{gap} \leq 50.0$	10^1	4.5	
		$0.0 < W_{gap} \leq 25.0$	25^1	0.0	
	25RB+75RB	$20 < W_{gap} \leq 45$	10^1	4.3	
		$0 < W_{gap} \leq 20$	25^1	0	
	25RB+100RB	$15 < W_{gap} \leq 40$	10^1	4.1	
		$0 < W_{gap} \leq 15$	25^1	0	
	50RB+25RB	$15.0 < W_{gap} \leq 50.0$	10^4	5.5	
		$0.0 < W_{gap} \leq 15.0$	32^1	0.0	
	50RB+50RB	$10.0 < W_{gap} \leq 45.0$	10^4	5.0	
		$0.0 < W_{gap} \leq 10.0$	32^1	0.0	
	50RB+75RB	$5 < W_{gap} \leq 40$	10^4	4.5	
		$0 < W_{gap} \leq 5$	32^1	0	
	50RB+100RB	$0 < W_{gap} \leq 35$	10^4	4.2	
		$10 < W_{gap} \leq 45$	10^{14}	7.6	
	75RB+25RB	$0 < W_{gap} \leq 10$	32^1	0	
		$5 < W_{gap} \leq 40$	10^{14}	6.7	
	75RB+50RB	$0 < W_{gap} \leq 5$	32^1	0	
		$0 < W_{gap} \leq 35$	10^{14}	5.6	
75RB+75RB	$0 < W_{gap} \leq 30$	10^{14}	4.8		
	$0 < W_{gap} \leq 40$	12^{15}	8		
100RB+25RB	$0 < W_{gap} \leq 40$	12^{15}	6.7		
	$0 < W_{gap} \leq 35$	12^{15}	6.1		
100RB+50RB	$0 < W_{gap} \leq 30$	12^{15}	6.1		
	$0 < W_{gap} \leq 25$	12^{15}	5.7		
CA_41A-41A	NOTE 6	NOTE 7	NOTE 8	0.0	TDD
CA_41A-41C	NOTE 6	NOTE 7	NOTE 8	0.0	TDD
CA_42A-42A	NOTE 6	NOTE 7	NOTE 8	0.0	TDD
<p>NOTE 1: ¹ refers to the UL resource blocks shall be located as close as possible to the downlink operating band but confined within the transmission.</p> <p>NOTE 2: W_{gap} is the sub-block gap between the two sub-blocks.</p> <p>NOTE 3: The carrier center frequency of PCC in the UL operating band is configured closer to the DL operating band.</p> <p>NOTE 4: ⁴ refers to the UL resource blocks shall be located at $RB_{start}=33$.</p> <p>NOTE 5: For the TDD intra-band non-contiguous CA configurations, the minimum requirements apply only in synchronized operation between all component carriers.</p> <p>NOTE 6: All combinations of channel bandwidths defined in Table 5.6A.1-3.</p> <p>NOTE 7: All applicable sub-block gap sizes.</p>					

NOTE 8: The PCC allocation is same as Transmission bandwidth configuration N_{RB} as defined in Table 5.6-1.
NOTE 9: ⁹ refers to the UL resource blocks shall be located at $RB_{start}=25$.
NOTE 10: ¹⁰ refers to the UL resource blocks shall be located at $RB_{start}=35$.
NOTE 11: ¹¹ refers to the UL resource blocks shall be located at $RB_{start}=50$.
NOTE 12: ¹² refers to the UL resource blocks shall be located at $RB_{start}=39$.
NOTE 13: ¹³ refers to the UL resource blocks shall be located at $RB_{start}=57$.
NOTE 14: ¹⁴ refers to the UL resource blocks shall be located at $RB_{start}=44$.
NOTE 15: ¹⁵ refers to the UL resource blocks shall be located at $RB_{start}=62$.

For intra-band non-contiguous carrier aggregation with two uplink and downlink carriers the reference sensitivity is defined to be met with both downlink and uplink carriers activated. The downlink PCC and SCC minimum requirements for reference sensitivity as specified in Table 7.3.1-1 are increased by amount of ΔR_{2UL_PCC} and ΔR_{2UL_SCC} which are defined in Table 7.3.1A-4 when uplink PCC and SCC allocations are according to the Table 7.3.1A-4.

Table 7.3.1A-4: Intra-band non-contiguous CA with two uplinks configuration for reference sensitivity

CA configuration	Aggregated channel bandwidth (PCC+SCC)	W_{gap} / [MHz]	UL PCC allocation	UL SCC allocation	ΔR_{2UL_PCC} (dB)	ΔR_{2UL_SCC} (dB)	Duplex mode
CA_4A-4A	NOTE 2	NOTE 3	NOTE 4	NOTE 5	0.0	0.0	FDD
NOTE 1: The transmitter shall be set to P_{UMAX} as defined in subclause 6.2.5A.							
NOTE 2: All combinations of channel bandwidths defined in Table 5.6A.1-3.							
NOTE 3: All applicable sub-block gap sizes.							
NOTE 4: The PCC allocation is same as Transmission bandwidth configuration N_{RB} as defined in Table 5.6-1.							
NOTE 5: The SCC allocation is same as Transmission bandwidth configuration N_{RB} as defined in Table 5.6-1.							

For combinations of intra-band contiguous and inter-band carrier aggregation with three downlink carriers and one uplink carrier assigned to one E-UTRA band, the requirement is defined with an uplink configuration in accordance with Table 7.3.1-2 for each band capable of uplink operation. The downlink PCC carrier center frequency shall be configured closer to the uplink operating band than the downlink SCC center frequency when the uplink is active in the band supporting two component carriers. For these uplink configurations, the UE shall meet the reference sensitivity requirements for intra-band contiguous carrier aggregation of two downlink carriers and for the remaining component carrier the requirements specified in subclause 7.3.1. The three downlink carriers shall be active throughout the tests. Unless given by Table 7.3.1-3, the reference sensitivity requirements shall be verified with the network signalling value NS_01 (Table 6.2.4-1) configured.

For combinations of intra-band non-contiguous and inter-band carrier aggregation with three downlink carriers and one uplink carrier assigned to one E-UTRA band, the requirement is defined with an uplink configuration in accordance with Table 7.3.1A-3 when the uplink is active in the band supporting two component carriers and in accordance with Table 7.3.1-2 when the uplink is active in the other band. The carrier center frequency of PCC in the UL operating band is configured closer to the DL operating band when the uplink is active in the band supporting non-contiguous aggregation of two component carriers. For these uplink configurations, the UE shall meet the reference sensitivity requirements for intra-band non-contiguous carrier aggregation of two downlink carriers and for the remaining component carrier the requirements specified in subclause 7.3.1. For the two component carriers within the same band, $\Delta R_{IBNC} = 0$ dB for all sub-block gaps (Table 7.3.1A-3) when the uplink is active in the band supporting the single component carrier. The three downlink carriers shall be active throughout the tests. Unless given by Table 7.3.1-3, the reference sensitivity requirements shall be verified with the network signalling value NS_01 (Table 6.2.4-1) configured.

For the UE that supports any of combinations of intra-band and inter-band carrier aggregation given in Table 7.3.1A-5, exceptions to the aforementioned requirements are allowed when the uplink is active in a lower-frequency band and is within a specified frequency range such that transmitter harmonics fall within the downlink transmission bandwidth assigned in a higher band as noted in Table 7.3.1A-5. For these exceptions, the UE shall meet the requirements specified in Table 7.3.1A-5 and Table 7.3.1A-6.

Table 7.3.1A-5: Reference sensitivity for carrier aggregation QPSK $P_{\text{REFSENS, CA}}$ (exceptions due to harmonic issues in the combinations of intra-band and inter-band CA)

Channel bandwidth								
EUTRA CA Configuration	EUTRA band	1.4 MHz (dBm)	3 MHz (dBm)	5 MHz (dBm)	10 MHz (dBm)	15 MHz (dBm)	20 MHz (dBm)	Duplex mode
CA_3A-42C ^{7,8}	3			-96.8	-93.8	-92	-90.8	FDD
	42			-71.7	-71.7	-71.7	-71.7	TDD
CA_3A-42C ⁹	3			-96.8	-93.8	-92	-90.8	FDD
	42			-97.1	-94.7	-93.2	-92.5	TDD
CA_4A-4A-12A ^{4,5}	4			-90	-89.5	-89	-88.5	FDD
	12			-96.5	-93.5			
CA_4A-12B ^{4,5}	4			-90	-89.5	-89	-88.5	FDD
	12			-96.5	-93.5			
CA_26A-41C ⁶	26			N/A	N/A	N/A	N/A	FDD
	41			N/A	N/A	N/A	N/A	TDD

NOTE 1: The transmitter shall be set to P_{UMAX} as defined in subclause 6.2.5A.

NOTE 2: Reference measurement channel is A.3.2 with one sided dynamic OCNG Pattern OP.1 FDD/TDD as described in Annex A.5.1.1/A.5.2.1

NOTE 3: The signal power is specified per port

NOTE 4: These requirements apply when there is at least one individual RE within the uplink transmission bandwidth of a low band for which the 3rd transmitter harmonic is within the downlink transmission bandwidth of a high band.

NOTE 5: The requirements should be verified for UL EARFCN of a low band (superscript LB) such that $f_{\text{UL}}^{\text{LB}} = \lfloor f_{\text{DL}}^{\text{HB}} / 0.3 \rfloor 0.1$ in MHz and $F_{\text{UL}_{\text{low}}}^{\text{LB}} + BW_{\text{Channel}}^{\text{LB}} / 2 \leq f_{\text{UL}}^{\text{LB}} \leq F_{\text{UL}_{\text{high}}}^{\text{LB}} - BW_{\text{Channel}}^{\text{LB}} / 2$ with $f_{\text{DL}}^{\text{HB}}$ the carrier frequency of a high band in MHz and $BW_{\text{Channel}}^{\text{LB}}$ the channel bandwidth configured in the low band.

NOTE 6: No requirements apply when there is at least one individual RE within the uplink transmission bandwidth of the low band for which the 3rd transmitter harmonic is within the downlink transmission bandwidth of the high band. The reference sensitivity is only verified when this is not the case (the requirements specified in clause 7.3.1 apply).

NOTE 7: These requirements apply when there is at least one individual RE within the uplink transmission bandwidth of the aggressor (lower) band for which the 2nd transmitter harmonic is within the downlink transmission bandwidth of a victim (higher) band and a range ΔF_{HD} above and below the edge of this downlink transmission bandwidth. The value ΔF_{HD} depends on the E-UTRA configuration: $\Delta F_{\text{HD}} = 10$ MHz for CA_3A-42C.

NOTE 8: The requirements should be verified for UL EARFCN of the aggressor (lower) band (superscript LB) such that $f_{\text{UL}}^{\text{LB}} = \lfloor f_{\text{DL}}^{\text{HB}} / 0.2 \rfloor 0.1$ in MHz and $F_{\text{UL}_{\text{low}}}^{\text{LB}} + BW_{\text{Channel}}^{\text{LB}} / 2 \leq f_{\text{UL}}^{\text{LB}} \leq F_{\text{UL}_{\text{high}}}^{\text{LB}} - BW_{\text{Channel}}^{\text{LB}} / 2$ with $f_{\text{DL}}^{\text{HB}}$ carrier frequency in the victim (higher) band in MHz and $BW_{\text{Channel}}^{\text{LB}}$ the channel bandwidth configured in the lower band.

NOTE 9: The requirements are only applicable to channel bandwidths with a carrier frequency at $\pm (20 + BW_{\text{Channel}}^{\text{HB}} / 2)$ MHz offset from $2f_{\text{UL}}^{\text{LB}}$ in the victim (higher) band with $F_{\text{UL}_{\text{low}}}^{\text{LB}} + BW_{\text{Channel}}^{\text{LB}} / 2 \leq f_{\text{UL}}^{\text{LB}} \leq F_{\text{UL}_{\text{high}}}^{\text{LB}} - BW_{\text{Channel}}^{\text{LB}} / 2$, where $BW_{\text{Channel}}^{\text{LB}}$ and $BW_{\text{Channel}}^{\text{HB}}$ are the channel bandwidths configured in the aggressor (lower) and victim (higher) bands in MHz, respectively.

Table 7.3.1A-6: Uplink configuration for the low band (exceptions due to harmonic issues in the combinations of intra-band and inter-band CA)

E-UTRA Band / Channel bandwidth of the high band / N _{RB} / Duplex mode								
EUTRA CA Configuration	UL band	1.4 MHz	3 MHz	5 MHz	10 MHz	15 MHz	20 MHz	Duplex mode
CA_3A-42C	3			12	25	36	50	FDD
CA_4A-4A-12A	12			8	16	20	20	FDD
CA_4A-12B	12			8	16	20	20	FDD
NOTE 1: refers to the UL resource blocks, which shall be centred within the transmission bandwidth configuration for the channel bandwidth.								
NOTE 2: the UL configuration applies regardless of the channel bandwidth of the low band unless the UL resource blocks exceed that specified in Table 7.3.1-2 for the uplink bandwidth in which case the allocation according to Table 7.3.1-2 applies.								

7.3.1B Minimum requirements (QPSK) for UL-MIMO

For UE with two transmitter antenna connectors in closed-loop spatial multiplexing scheme, the minimum requirements in Clause 7.3.1 shall be met with the UL-MIMO configurations specified in Table 6.2.2B-2. For UL-MIMO, the parameter P_{UMAX} is the total transmitter power over the two transmits power over the two transmit antenna connectors.

7.3.1D Minimum requirements (QPSK) for ProSe

The throughput shall be $\geq 95\%$ of the maximum throughput of the reference measurement channels as specified in Annexes A.6.2 with parameters specified in Table 7.3.1D-1 and Table 7.3.1D-2.

Table 7.3.1D-1: Reference sensitivity for ProSe Direct Discovery QPSK P_{REFSENS}

E-UTRA ProSe Band	Channel bandwidth						Duplex Mode
	1.4 MHz (dBm)	3 MHz (dBm)	5 MHz (dBm)	10 MHz (dBm)	15 MHz (dBm)	20 MHz (dBm)	
2			-104.1	-104.1	-104.1	-104.1	HD
3			-103.1	-103.1	-103.1	-103.1	HD
4			-106.1	-106.1	-106.1	-106.1	HD
7			-103.8	-103.8	-103.8	-103.8	HD
14			-103.1	-103.1			HD
20			-103.2	-103.2	-102.2	-102.2	HD
26			-103.5 ⁵	-103.5 ⁵	-103.5 ⁵		HD
28			-104.4	-104.4	-104.4	-102.9	HD
31			-99.5				HD
NOTE 1: Reference measurement channel is A.6.2							
NOTE 2: The signal power is specified per port							
NOTE 3: For the UE which supports both Band 3 and Band 9 the reference sensitivity level is FFS.							
NOTE 4: For the UE which supports both Band 11 and Band 21 the reference sensitivity level is FFS.							
NOTE 5: ⁵ indicates that the requirement is modified by -0.5 dB when the carrier frequency of the assigned E-UTRA channel bandwidth is within 865-894 MHz.							
NOTE 6: For a UE that support both Band 18 and Band 26, the reference sensitivity level for Band 26 applies for the applicable channel bandwidths.							

Table 7.3.1D-2: Reference sensitivity for ProSe Direct Communication QPSK P_{REFSENS}

E-UTRA ProSe Band	Channel bandwidth						Duplex Mode
	1.4 MHz (dBm)	3 MHz (dBm)	5 MHz (dBm)	10 MHz (dBm)	15 MHz (dBm)	20 MHz (dBm)	
3				-97.6			HD
7				-98.3			HD
14				-97.6			HD
20				-97.7			HD
26				-98.0 ⁵			HD
28				-98.9			HD
31			-96.7				HD
NOTE 1: Reference measurement channel is A.6.2							
NOTE 2: The signal power is specified per port							
NOTE 3: For the UE which supports both Band 3 and Band 9 the reference sensitivity level is FFS.							
NOTE 4: For the UE which supports both Band 11 and Band 21 the reference sensitivity level is FFS.							
NOTE 5: ⁵ indicates that the requirement is modified by -0.5 dB when the carrier frequency of the assigned E-UTRA channel bandwidth is within 865-894 MHz.							
NOTE 6: For a UE that support both Band 18 and Band 26, the reference sensitivity level for Band 26 applies for the applicable channel bandwidths.							

NOTE: Table 7.3.1D-1/ Table 7.3.1D-2 is intended for conformance tests and does not necessarily reflect the operational conditions of the network, where the number of allocated resource blocks will be practically constrained by other factors.

For the UE which supports ProSe in an operating band as specified in Section 5.5D and is configured with (and can transmit on) only PCell, and the UE also supports a E-UTRA downlink inter-band carrier aggregation configuration in Table 7.3.1-1A or Table 7.3.1-1B, the minimum requirement for reference sensitivity in Table 7.3.1D-1 and Table 7.3.1D-2 shall be increased by the amount given in $\Delta R_{\text{IB},c}$ in Table 7.3.1-1A and Table 7.3.1-1B for the corresponding E-UTRA ProSe band.

7.3.1E Minimum requirements (QPSK) for UE category 0

The throughput shall be $\geq 95\%$ of the maximum throughput of the reference measurement channels as specified in Annexes A.2.2, A.2.3 and A.3.2 (with one sided dynamic OCNG Pattern OP.1 FDD/TDD for the DL-signal as described in Annex A.5.1.1/A.5.2.1) with parameters specified in Table 7.3.1E-1A/Table 7.3.1E-1B and Table 7.3.1E-2.

Table 7.3.1E-1A: Reference sensitivity for FDD and TDD UE category 0 QPSK P_{REFSENS}

E-UTRA Band	Channel bandwidth						Duplex Mode
	1.4 MHz (dBm)	3 MHz (dBm)	5 MHz (dBm)	10 MHz (dBm)	15 MHz (dBm)	20 MHz (dBm)	
2	-100.2	-97.2	-95.5	-92.5	-90.7	-89.5	FDD
3	-99.2	-96.2	-94.5	-91.5	-89.7	-88.5	FDD
4	-102.2	-99.2	-97.5	-94.5	-92.7	-91.5	FDD
5	-100.7	-97.7	-95.5	-92.5			FDD
8	-99.7	-96.7	-94.5	-91.5			FDD
13			-94	-91			FDD
20			-94.5	-91.5	-88.2	-87	FDD
39			-97.5	-94.5	-92.7	-91.5	TDD
41			-95.5	-92.5	-90.7	-89.5	TDD
NOTE 1: The transmitter shall be set to P_{UMAX} as defined in subclause 6.2.5							
NOTE 2: Reference measurement channel is A.3.2 with one sided dynamic OCNG Pattern OP.1 FDD/TDD as described in Annex A.5.1.1/A.5.2.1							

Table 7.3.1E-1B: Reference sensitivity for HD-FDD UE category 0 QPSK P_{REFSENS}

Channel bandwidth							
E-UTRA Band	1.4 MHz (dBm)	3 MHz (dBm)	5 MHz (dBm)	10 MHz (dBm)	15 MHz (dBm)	20 MHz (dBm)	Duplex Mode
2	-101	-98	-96.3	-93.3	-91.5	-90.3	HD-FDD
3	-100	-97	-95.3	-92.3	-90.5	-89.3	HD-FDD
4	-103	-100	-98.3	-95.3	-93.5	-92.3	HD-FDD
5	-101.5	-98.5	-96.3	-93.3			HD-FDD
8	-100.5	-97.5	-95.3	-92.3			HD-FDD
13			-95.3	-92.3			HD-FDD
20			-95.3	-92.3	-89.5	-88.3	HD-FDD

NOTE 1: The transmitter shall be set to P_{UMAX} as defined in subclause 6.2.5
NOTE 2: Reference measurement channel is A.3.2 with one sided dynamic OCNG Pattern OP.1 FDD/TDD as described in Annex A.5.1.1/A.5.2.1

The reference receive sensitivity (REFSENS) requirement specified in Table 7.3.1E-1A/Table 7.3.1E-1B shall be met for an uplink transmission bandwidth less than or equal to that specified in Table 7.3.1E-2.

NOTE: Table 7.3.1E-2 is intended for conformance tests and does not necessarily reflect the operational conditions of the network, where the number of uplink and downlink allocated resource blocks will be practically constrained by other factors. Typical receiver sensitivity performance with HARQ retransmission enabled and using a residual BLER metric relevant for e.g. Speech Services is given in the Annex X (informative).

Table 7.3.1E-2: FDD and TDD UE category 0 Uplink configuration for reference sensitivity

E-UTRA Band / Channel bandwidth / N_{RB} / Duplex mode							
E-UTRA Band	1.4 MHz	3 MHz	5 MHz	10 MHz	15 MHz	20 MHz	Duplex Mode
2	6	15	25	36 ¹	36 ¹	36 ¹	FDD and HD-FDD
3	6	15	25	36 ¹	36 ¹	36 ¹	FDD and HD-FDD
4	6	15	25	36 ¹	36 ¹	36 ¹	FDD and HD-FDD
5	6	15	25	25 ¹			FDD and HD-FDD
8	6	15	25	25 ¹			FDD and HD-FDD
13			20 ¹	20 ¹			FDD and HD-FDD
20			25	20 ¹	20 ²	20 ²	FDD and HD-FDD
39			25	36 ¹	36 ¹	36 ¹	TDD
41			25	36 ¹	36 ¹	36 ¹	TDD

NOTE 1: ¹ refers to the UL resource blocks shall be located as close as possible to the downlink operating band but confined within the transmission bandwidth configuration for the channel bandwidth (Table 5.6-1).
NOTE 2: ² refers to Band 20; in the case of 15MHz channel bandwidth, the UL resource blocks shall be located at $\text{RB}_{\text{start}} 11$ and in the case of 20MHz channel bandwidth, the UL resource blocks shall be located at $\text{RB}_{\text{start}} 16$.

7.3.2 Void

7.4 Maximum input level

This is defined as the maximum mean power received at the UE antenna port, at which the specified relative throughput shall meet or exceed the minimum requirements for the specified reference measurement channel.

7.4.1 Minimum requirements

The throughput shall be $\geq 95\%$ of the maximum throughput of the reference measurement channels as specified in Annexes A.2.2, A.2.3 and A.3.2 (with one sided dynamic OCNG Pattern OP.1 FDD/TDD as described in Annex A.5.1.1/A.5.2.1) with parameters specified in Table 7.4.1-1

Table 7.4.1-1: Maximum input level

Rx Parameter	Units	Channel bandwidth					
		1.4 MHz	3 MHz	5 MHz	10 MHz	15 MHz	20 MHz
Power in Transmission Bandwidth Configuration	dBm	-25 ²					
		-27 ³					
NOTE 1: The transmitter shall be set to 4dB below P _{CMAX,L} at the minimum uplink configuration specified in Table 7.3.1-2 with P _{CMAX,L} as defined in subclause 6.2.5.							
NOTE 2: Reference measurement channel is Annex A.3.2: 64QAM, R=3/4 variant with one sided dynamic OCNG Pattern OP.1 FDD/TDD as described in Annex A.5.1.1/A.5.2.1.							
NOTE 3: Reference measurement channel is Annex A.3.2: 256QAM, R=4/5 variant with one sided dynamic OCNG Pattern OP.1 FDD/TDD as described in Annex A.5.1.1/A.5.2.1.							

7.4.1A Minimum requirements for CA

For inter-band carrier aggregation with one component carrier per operating band and the uplink assigned to one E-UTRA band the maximum input level is defined with the uplink active on the band(s) other than the band whose downlink is being tested. For E-UTRA CA configurations including an operating band without uplink band, the requirements for all downlinks shall be met with the single uplink carrier active in each band capable of UL operation. The UE shall meet the requirements specified in subclause 7.4.1 for each component carrier while all downlink carriers are active.

For intra-band contiguous carrier aggregation maximum input level is defined as the powers received at the UE antenna port over the Transmission bandwidth configuration of each CC, at which the specified relative throughput shall meet or exceed the minimum requirements for the specified reference measurement channel over each component carrier.

The downlink SCC(s) shall be configured at nominal channel spacing to the PCC. For FDD the PCC shall be configured closest to the uplink band. All downlink carriers shall be active throughout the test. The uplink output power shall be set as specified in Table 7.4.1A-1 with the uplink configuration set according to Table 7.3.1A-1 for the applicable carrier aggregation configuration. For UE(s) supporting one uplink carrier, the uplink configuration of the PCC shall be in accordance with Table 7.3.1-2.

The throughput shall be $\geq 95\%$ of the maximum throughput of the reference measurement channels over each component carrier as specified in Annexes A.2.2, A.2.3 and A.3.2 (with one sided dynamic OCNG Pattern OP.1 FDD/TDD as described in Annex A.5.1.1/A.5.2.1) with parameters specified in Table 7.4.1A-1.

For intra-band non-contiguous carrier aggregation with one uplink carrier and two downlink sub-blocks, each larger than or equal to 5 MHz, the maximum input level requirements are defined with the uplink configuration in accordance with Table 7.3.1A-3. For this uplink configuration, the UE shall meet the requirements for each sub-block as specified in Table 7.4.1-1 and Table 7.4.1A-1 for one component carrier and two component carriers per sub-block, respectively. The throughput of each downlink component carrier shall be $\geq 95\%$ of the maximum throughput of the specified reference measurement channel as specified in Annexes A.2.2, A.2.3 and A.3.2 (with one sided dynamic OCNG Pattern OP.1 FDD/TDD as described in Annex A.5.1.1/A.5.2.1). The requirements apply with all downlink carriers active.

Table 7.4.1A-1: Maximum input level for intra-band contiguous CA

Rx Parameter	Units	CA Bandwidth Class					
		A	B	C	D	E	F
Power in largest Transmission Bandwidth Configuration CC	dBm		-28 ²	-25 ²	-25 ²		
			-30 ³	-27 ³	-27 ³		
Power in each other CC	dBm		-28+ $10\log(N_{RB,c} / N_{RB,largest\ BW})^2$	-25 + $10\log(N_{RB,c} / N_{RB,largest\ BW})^2$	-25 + $10\log(N_{RB,c} / N_{RB,largest\ BW})^2$		
			-30+ $10\log(N_{RB,c} / N_{RB,largest\ BW})^3$	-27 + $10\log(N_{RB,c} / N_{RB,largest\ BW})^3$	-27 + $10\log(N_{RB,c} / N_{RB,largest\ BW})^3$		
NOTE 1: The transmitter shall be set to 4dB below P _{CMAX_L,c} or P _{CMAX_L} as defined in subclause 6.2.5A.							
NOTE 2: Reference measurement channel is Annex A.3.2: 64QAM, R=3/4 variant with one sided dynamic OCNG Pattern OP.1 FDD/TDD as described in Annex A.5.1.1/A.5.2.1.							
NOTE 3: Reference measurement channel is Annex A.3.2: 256QAM, R=4/5 variant with one sided dynamic OCNG Pattern OP.1 FDD/TDD as described in Annex A.5.1.1/A.5.2.1.							

For combinations of intra-band contiguous and inter-band carrier aggregation with three downlink carriers and one uplink assigned to one E-UTRA band, the requirement is defined with the uplink active in the band other than that supporting the downlink(s) under test and a configuration in accordance with Table 7.3.1-2. The downlink PCC carrier center frequency shall be configured closer to the uplink operating band than the downlink SCC center frequency when the uplink is active in the band supporting two component carriers. For E-UTRA CA configurations including an operating band without uplink band, the requirements for all downlinks shall be met with the single uplink carrier active in each band capable of UL operation. For these uplink configurations, the UE shall meet the maximum input-level requirements for intra-band contiguous carrier aggregation of two downlink carriers and for the remaining component carrier the requirements specified in subclause 7.4.1. The three downlink carriers shall be active throughout the tests.

For combinations of intra-band non-contiguous and inter-band carrier aggregation with three downlink carriers and one uplink assigned to one E-UTRA band, the requirement is defined with the uplink active in the band other than that supporting the downlink(s) under test. The uplink configuration shall be in accordance with Table 7.3.1A-3 when the uplink is active in the band supporting two component carriers and in accordance with Table 7.3.1-2 when the uplink is active in the other band. For E-UTRA CA configurations including an operating band without uplink band, the requirements for all downlinks shall be met with the single uplink carrier active in each band capable of UL operation. For these uplink configurations, the UE shall meet the maximum input-level requirements for intra-band non-contiguous carrier aggregation of two downlink carriers and for the remaining component carrier the requirements specified in subclause 7.4.1. The three downlink carriers shall be active throughout the tests.

7.4.1B Minimum requirements for UL-MIMO

For UE with two transmitter antenna connectors in closed-loop spatial multiplexing, the minimum requirements in Clause 7.4.1 shall be met with the UL-MIMO configurations specified in Table 6.2.2B-2. For UL-MIMO, the parameter P_{CMAX_L} is defined as the total transmitter power over the two transmit antenna connectors.

7.4.1D Minimum requirements for ProSe

The throughput shall be $\geq 95\%$ of the maximum throughput of the reference measurement channels as specified in Annexes A.6.2.

Table 7.4.1D-1: Maximum input level for ProSe

Rx Parameter	Units	Channel bandwidth					
		1.4 MHz	3 MHz	5 MHz	10 MHz	15 MHz	20 MHz
Power in Transmission Bandwidth Configuration	dBm	-22					
NOTE 1: Reference measurement channel is Annex A.6.2							

7.4A Void

7.4A.1 Void

7.5 Adjacent Channel Selectivity (ACS)

Adjacent Channel Selectivity (ACS) is a measure of a receiver's ability to receive a E-UTRA signal at its assigned channel frequency in the presence of an adjacent channel signal at a given frequency offset from the centre frequency of the assigned channel. ACS is the ratio of the receive filter attenuation on the assigned channel frequency to the receive filter attenuation on the adjacent channel(s).

7.5.1 Minimum requirements

The UE shall fulfil the minimum requirement specified in Table 7.5.1-1 for all values of an adjacent channel interferer up to -25 dBm. However it is not possible to directly measure the ACS, instead the lower and upper range of test parameters are chosen in Table 7.5.1-2 and Table 7.5.1-3 where the throughput shall be $\geq 95\%$ of the maximum throughput of the reference measurement channels as specified in Annexes A.2.2, A.2.3 and A.3.2 (with one sided dynamic OCNB Pattern OP.1 FDD/TDD for the DL-signal as described in Annex A.5.1.1/A.5.2.1).

Table 7.5.1-1: Adjacent channel selectivity

Rx Parameter	Units	Channel bandwidth					
		1.4 MHz	3 MHz	5 MHz	10 MHz	15 MHz	20 MHz
ACS	dB	33.0	33.0	33.0	33.0	30	27

Table 7.5.1-2: Test parameters for Adjacent channel selectivity, Case 1

Rx Parameter	Units	Channel bandwidth					
		1.4 MHz	3 MHz	5 MHz	10 MHz	15 MHz	20 MHz
Power in Transmission Bandwidth Configuration	dBm	REFSENS + 14 dB					
$P_{\text{Interferer}}$	dBm	REFSENS +45.5dB	REFSENS +45.5dB	REFSENS +45.5dB	REFSENS +45.5dB	REFSENS +42.5dB	REFSENS +39.5dB
$BW_{\text{Interferer}}$	MHz	1.4	3	5	5	5	5
$F_{\text{Interferer}}$ (offset)	MHz	1.4+0.0025 / -1.4-0.0025	3+0.0075 / -3-0.0075	5+0.0025 / -5-0.0025	7.5+0.0075 / -7.5-0.0075	10+0.0125 / -10-0.0125	12.5+0.0025 / -12.5-0.0025
NOTE 1: The transmitter shall be set to 4dB below $P_{\text{CMAX_L}}$ at the minimum uplink configuration specified in Table 7.3.1-2 with $P_{\text{CMAX_L}}$ as defined in subclause 6.2.5.							
NOTE 2: The interferer consists of the Reference measurement channel specified in Annex A.3.2 with one sided dynamic OCNB Pattern OP.1 FDD/TDD as described in Annex A.5.1.1/A.5.2.1 and set-up according to Annex C.3.1							

Table 7.5.1-3: Test parameters for Adjacent channel selectivity, Case 2

Rx Parameter	Units	Channel bandwidth					
		1.4 MHz	3 MHz	5 MHz	10 MHz	15 MHz	20 MHz
Power in Transmission Bandwidth Configuration	dBm	-56.5	-56.5	-56.5	-56.5	-53.5	-50.5
$P_{\text{Interferer}}$	dBm	-25					
$BW_{\text{Interferer}}$	MHz	1.4	3	5	5	5	5
$F_{\text{Interferer}}$ (offset)	MHz	1.4+0.0025 / -1.4-0.0025	3+0.0075 / -3-0.0075	5+0.0025 / -5-0.0025	7.5+0.0075 / -7.5-0.0075	10+0.0125 / -10-0.0125	12.5+0.0025 / -12.5-0.0025
NOTE 1: The transmitter shall be set to 24dB below $P_{\text{CMAX_L}}$ at the minimum uplink configuration specified in Table 7.3.1-2 with $P_{\text{CMAX_L}}$ as defined in subclause 6.2.5.							
NOTE 2: The interferer consists of the Reference measurement channel specified in Annex 3.2 with one sided dynamic OCNG Pattern OP.1 FDD/TDD as described in Annex A.5.1.1/A.5.2.1 and set-up according to Annex C.3.1.							

7.5.1A Minimum requirements for CA

For inter-band carrier aggregation with one component carrier per operating band and the uplink assigned to one E-UTRA band, the adjacent channel requirements are defined with the uplink active on the band(s) other than the band whose downlink is being tested. The UE shall meet the requirements specified in subclause 7.5.1 for each component carrier while all downlink carriers are active. For E-UTRA CA configurations including an operating band without uplink band (as noted in Table 5.5-1), the requirements for all downlinks shall be met with the single uplink carrier active in each band capable of UL operation. For E-UTRA CA configurations listed in Table 7.3.1A-0a under conditions for which reference sensitivity for the operating band being tested is N/A, the adjacent channel requirements of subclause 7.5.1A do not apply.

For intra-band contiguous carrier aggregation the downlink SCC(s) shall be configured at nominal channel spacing to the PCC. For FDD, the PCC shall be configured closest to the uplink band. All downlink carriers shall be active throughout the test. The uplink output power shall be set as specified in Table 7.5.1A-2 and Table 7.5.1A-3 with the uplink configuration set according to Table 7.3.1A-1 for the applicable carrier aggregation configuration. For UE(s) supporting one uplink carrier, the uplink configuration of the PCC shall be in accordance with Table 7.3.1-2. The UE shall fulfil the minimum requirement specified in Table 7.5.1A-1 for an adjacent channel interferer on either side of the aggregated downlink signal at a specified frequency offset and for an interferer power up to -25 dBm. The throughput of each carrier shall be $\geq 95\%$ of the maximum throughput of the reference measurement channels as specified in Annexes A.2.2, A.2.3 and A.3.2 (with one sided dynamic OCNG Pattern OP.1 FDD/TDD for the DL-signal as described in Annex A.5.1.1/A.5.2.1) with parameters specified in Tables 7.5.1A-2 and 7.5.1A-3.

For intra-band non-contiguous carrier aggregation with one uplink carrier and two downlink sub-blocks, each larger than or equal to 5 MHz, the adjacent channel selectivity requirements are defined with the uplink configuration in accordance with Table 7.3.1A-3. For this uplink configuration, the UE shall meet the requirements for each sub-block as specified in subclauses 7.5.1 and 7.5.1A for one component carrier and two component carriers per sub-block, respectively. The UE shall fulfil the minimum requirements all values of a single adjacent channel interferer in-gap and out-of-gap up to a -25 dBm interferer power while all downlink carriers are active. For the lower range of test parameters (Case 1), the interferer power $P_{\text{interferer}}$ shall be set to the maximum of the levels given by the carriers of the respective sub-blocks as specified in Table 7.5.1-2 and Table 7.5.1A-2 for one component carrier and two component carriers per sub-block, respectively. The wanted signal power levels for the carriers of each sub-block shall then be adjusted relative to $P_{\text{interferer}}$ in accordance with the ACS requirement for each sub-block (Table 7.5.1-1 and Table 7.5.1A-1). For the upper range of test parameters (Case 2) for which the interferer power $P_{\text{interferer}}$ is -25 dBm (Table 7.5.1-3 and Table 7.5.1A-3) the wanted signal power levels for the carriers of each sub-block shall be adjusted relative to $P_{\text{interferer}}$ like for Case 1.

Table 7.5.1A-1: Adjacent channel selectivity

Rx Parameter	Units	CA Bandwidth Class				
		B	C	D	E	F
ACS	dB	27	24	22.2		

Table 7.5.1A-2: Test parameters for Adjacent channel selectivity, Case 1

Rx Parameter	Units	CA Bandwidth Class				
		B	C	D	E	F
Pw in Transmission Bandwidth Configuration, per CC		REFSENS + 14 dB	REFSENS + 14 dB	REFSENS + 14 dB		
$P_{\text{Interferer}}$	dBm	Aggregated power + 25.5 dB	Aggregated power + 22.5 dB	Aggregated power + 20.7 dB		
$BW_{\text{Interferer}}$	MHz	5	5	5		
$F_{\text{Interferer}}$ (offset)	MHz	$2.5 + F_{\text{offset}}$ / $-2.5 - F_{\text{offset}}$	$2.5 + F_{\text{offset}}$ / $-2.5 - F_{\text{offset}}$	$2.5 + F_{\text{offset}}$ / $-2.5 - F_{\text{offset}}$		
NOTE 1: The transmitter shall be set to 4dB below $P_{\text{C}_{\text{MAX_L,c}}}$ or $P_{\text{C}_{\text{MAX_L}}}$ as defined in subclause 6.2.5A.						
NOTE 2: The interferer consists of the Reference measurement channel specified in Annex A.3.2 with one sided dynamic OCNG Pattern OP.1 FDD/TDD as described in Annex A.5.1.1/A.5.2.1 and set-up according to Annex C.3.1						
NOTE 3: The $F_{\text{Interferer}}$ (offset) is the frequency separation of the center frequency of the carrier closest to the interferer and the center frequency of the adjacent channel interferer and shall be further adjusted to $\lfloor F_{\text{Interferer}} / 0.015 + 0.5 \rfloor 0.015 + 0.0075$ MHz to be offset from the sub-carrier raster.						

Table 7.5.1A-3: Test parameters for Adjacent channel selectivity, Case 2

Rx Parameter	Units	CA Bandwidth Class				
		B	C	D	E	F
Pw in Transmission Bandwidth Configuration, per CC	dBm	$-50.5 + 10\log_{10}(N_{\text{RB,c}}/N_{\text{RB,agg}})$	$-47.5 + 10\log_{10}(N_{\text{RB,c}}/N_{\text{RB,agg}})$	$-45.7 + 10\log_{10}(N_{\text{RB,c}}/N_{\text{RB,agg}})$		
$P_{\text{Interferer}}$	dBm	-25				
$BW_{\text{Interferer}}$	MHz	5	5	5		
$F_{\text{Interferer}}$ (offset)	MHz	$2.5 + F_{\text{offset}}$ / $-2.5 - F_{\text{offset}}$	$2.5 + F_{\text{offset}}$ / $-2.5 - F_{\text{offset}}$	$2.5 + F_{\text{offset}}$ / $-2.5 - F_{\text{offset}}$		
NOTE 1: The transmitter shall be set to 24dB below $P_{\text{C}_{\text{MAX_L,c}}}$ or $P_{\text{C}_{\text{MAX_L}}}$ as defined in subclause 6.2.5A.						
NOTE 2: The interferer consists of the Reference measurement channel specified in Annex 3.2 with one sided dynamic OCNG Pattern OP.1 FDD/TDD as described in Annex A.5.1.1/A.5.2.1 and set-up according to Annex C.3.1						
NOTE 3: The $F_{\text{Interferer}}$ (offset) is the frequency separation of the center frequency of the carrier closest to the interferer and the center frequency of the adjacent channel interferer and shall be further adjusted to $\lfloor F_{\text{Interferer}} / 0.015 + 0.5 \rfloor 0.015 + 0.0075$ MHz to be offset from the sub-carrier raster.						

For combinations of intra-band contiguous and inter-band carrier aggregation with three downlink carriers and one uplink carrier assigned to one E-UTRA band, the requirement is defined with the uplink active in the band other than that supporting the downlink(s) under test and a configuration in accordance with Table 7.3.1-2. The downlink PCC carrier center frequency shall be configured closer to the uplink operating band than the downlink SCC center frequency when the uplink is active in the band supporting two component carriers. For E-UTRA CA configurations including an operating band without uplink band, the requirements for all downlinks shall be met with the single uplink carrier active in each band capable of UL operation. For these uplink configurations, the UE shall meet the adjacent channel selectivity requirements for intra-band contiguous carrier aggregation of two downlink carriers and for the remaining component carrier the requirements specified in subclause 7.5.1. The three downlink carriers shall be active throughout the tests.

For combinations of intra-band non-contiguous and inter-band carrier aggregation with three downlink carriers and one uplink carrier assigned to one E-UTRA band, the requirement is defined with the uplink active in the band other than that supporting the downlink(s) under test. The uplink configuration shall be in accordance with Table 7.3.1A-3 when the uplink is active in the band supporting two component carriers and in accordance with Table 7.3.1-2 when the uplink is active in the other band. For E-UTRA CA configurations including an operating band without uplink band, the requirements for all downlinks shall be met with the single uplink carrier active in each band capable of UL operation. For these uplink configurations, the UE shall meet the adjacent channel selectivity requirements for intra-band non-contiguous carrier aggregation of two downlink carriers with $\Delta R_{\text{IBNC}} = 0$ dB for all sub-block gaps (Table 7.3.1A-3) and

for the remaining component carrier the the requirements specified in subclause 7.5.1. The three downlink carriers shall be active throughout the tests.

7.5.1B Minimum requirements for UL-MIMO

For UE(s) with two transmitter antenna connectors in closed-loop spatial multiplexing scheme, the minimum requirements in Clause 7.5.1 shall be met with the UL-MIMO configurations specified in Table 6.2.2B-2. For UL-MIMO, the parameter $P_{\text{CMAX,L}}$ is defined as the total transmitter power over the two transmit antenna connectors.

7.5.1D Minimum requirements for ProSe

The UE shall fulfil the minimum requirement specified in Table 7.5.1D-1 for all values of an adjacent channel interferer up to -25 dBm. However it is not possible to directly measure the ACS, instead the lower and upper range of test parameters are chosen in Table 7.5.1D-2 and Table 7.5.1D-3 where the throughput shall be $\geq 95\%$ of the maximum throughput of the reference measurement channels as specified in Annex A.6.2.

Table 7.5.1D-1: Adjacent channel selectivity for ProSe

Rx Parameter	Units	Channel bandwidth					
		1.4 MHz	3 MHz	5 MHz	10 MHz	15 MHz	20 MHz
ACS	dB			33.0	33.0	30	27

Table 7.5.1D-2: Test parameters for Adjacent channel selectivity for ProSe, Case 1

Rx Parameter	Units	Channel bandwidth					
		1.4 MHz	3 MHz	5 MHz	10 MHz	15 MHz	20 MHz
Power in Transmission Bandwidth Configuration	dBm	$P_{\text{REFSENS_ProSe}} + 14$ dB					
$P_{\text{Interferer}}$	dBm			REFSENS +45.5dB	REFSENS +45.5dB	REFSENS +42.5dB	REFSENS +39.5dB
$BW_{\text{Interferer}}$	MHz			5	5	5	5
$F_{\text{Interferer}}$ (offset)	MHz			5+0.0025 / -5-0.0025	7.5+0.0075 / -7.5-0.0075	10+0.0125 / -10-0.0125	12.5+0.0025 / -12.5-0.0025
NOTE 1: The interferer is QPSK modulated PUSCH containing data and reference symbols. Normal cyclic prefix is used. The data content shall be uncorrelated to the wanted signal and modulated according to clause 5 of TS36.211.							

Table 7.5.1D-3: Test parameters for Adjacent channel selectivity for ProSe, Case 2

Rx Parameter	Units	Channel bandwidth					
		1.4 MHz	3 MHz	5 MHz	10 MHz	15 MHz	20 MHz
Power in Transmission Bandwidth Configuration	dBm			-56.5	-56.5	-53.5	-50.5
$P_{\text{Interferer}}$	dBm	-25					
$BW_{\text{Interferer}}$	MHz			5	5	5	5
$F_{\text{Interferer}}$ (offset)	MHz			5+0.0025 / -5-0.0025	7.5+0.0075 / -7.5-0.0075	10+0.0125 / -10-0.0125	12.5+0.0025 / -12.5-0.0025
NOTE 1: The interferer is QPSK modulated PUSCH containing data and reference symbols. Normal cyclic prefix is used. The data content shall be uncorrelated to the wanted signal and modulated according to clause 5 of TS36.211.							

7.6 Blocking characteristics

The blocking characteristic is a measure of the receiver's ability to receive a wanted signal at its assigned channel frequency in the presence of an unwanted interferer on frequencies other than those of the spurious response or the adjacent channels, without this unwanted input signal causing a degradation of the performance of the receiver beyond a specified limit. The blocking performance shall apply at all frequencies except those at which a spurious response occur.

7.6.1 In-band blocking

In-band blocking is defined for an unwanted interfering signal falling into the UE receive band or into the first 15 MHz below or above the UE receive band at which the relative throughput shall meet or exceed the minimum requirement for the specified measurement channels..

7.6.1.1 Minimum requirements

The throughput shall be $\geq 95\%$ of the maximum throughput of the reference measurement channels as specified in Annexes A.2.2, A.2.3 and A.3.2 (with one sided dynamic OCNB Pattern OP.1 FDD/TDD for the DL-signal as described in Annex A.5.1.1/A.5.2.1) with parameters specified in Tables 7.6.1.1-1 and 7.6.1.1-2.

Table 7.6.1.1-1: In band blocking parameters

Rx parameter	Units	Channel bandwidth					
		1.4 MHz	3 MHz	5 MHz	10 MHz	15 MHz	20 MHz
Power in Transmission Bandwidth Configuration	dBm	REFSENS + channel bandwidth specific value below					
		6	6	6	6	7	9
BW _{Interferer}	MHz	1.4	3	5	5	5	5
F _{offset, case 1}	MHz	2.1+0.0125	4.5+0.0075	7.5+0.0125	7.5+0.0025	7.5+0.0075	7.5+0.0125
F _{offset, case 2}	MHz	3.5+0.0075	7.5+0.0075	12.5+0.0075	12.5+0.0125	12.5+0.0025	12.5+0.0075
NOTE 1: The transmitter shall be set to 4dB below P _{C_{MAX,L}} at the minimum uplink configuration specified in Table 7.3.1-2 with P _{C_{MAX,L}} as defined in subclause 6.2.5.							
NOTE 2: The interferer consists of the Reference measurement channel specified in Annex A.3.2 with one sided dynamic OCNB Pattern OP.1 FDD/TDD as described in Annex A.5.1.1/A.5.2.1 and set-up according to Annex C.3.1							

Table 7.6.1.1-2: In-band blocking

E-UTRA band	Parameter	Unit	Case 1	Case 2	Case 3	Case 4	Case 5
		$P_{\text{Interferer}}$	dBm	-56	-44		
	$F_{\text{Interferer}}$ (offset)	MHz	$= -BW/2 - F_{\text{offset, case 1}}$ & $= +BW/2 + F_{\text{offset, case 1}}$	$\leq -BW/2 - F_{\text{offset, case 2}}$ & $\geq +BW/2 + F_{\text{offset, case 2}}$			$-BW/2 - 11$
1, 2, 3, 4, 5, 6, 7, 8, 9, 10, 11, 12, 13, 14, 17, 18, 19, 20, 21, 22, 23, 25, 26, 27, 28, 31, 33, 34, 35, 36, 37, 38, 39, 40, 41, 42, 43, 44	$F_{\text{Interferer}}$	MHz	(Note 2)	$F_{\text{DL_low}} - 15$ to $F_{\text{DL_high}} + 15$	Void	Void	
30	$F_{\text{Interferer}}$	MHz	(Note 2)	$F_{\text{DL_low}} - 15$ to $F_{\text{DL_high}} + 15$			$F_{\text{DL_low}} - 11$
NOTE 1: For certain bands, the unwanted modulated interfering signal may not fall inside the UE receive band, but within the first 15 MHz below or above the UE receive band NOTE 2: For each carrier frequency the requirement is valid for two frequencies: a. the carrier frequency $-BW/2 - F_{\text{offset, case 1}}$ and b. the carrier frequency $+BW/2 + F_{\text{offset, case 1}}$ NOTE 3: $F_{\text{Interferer}}$ range values for unwanted modulated interfering signal are interferer center frequencies							

For the UE which supports inter band CA configuration in Table 7.3.1-1A, $P_{\text{Interferer}}$ power defined in Table 7.6.1.1-2 is increased by the amount given by $\Delta R_{\text{IB,c}}$ in Table 7.3.1-1A.

7.6.1.1A Minimum requirements for CA

For inter-band carrier aggregation with one component carrier per operating band and the uplink assigned to one E-UTRA band the in-band blocking requirements are defined with the uplink active on the band(s) other than the band whose downlink is being tested. The UE shall meet the requirements specified in subclause 7.6.1.1 for each component carrier while all downlink carriers are active. For the UE which supports inter band CA configuration in Table 7.3.1-1A, $P_{\text{Interferer}}$ power defined in Table 7.6.1.1-2 is increased by the amount given by $\Delta R_{\text{IB,c}}$ in Table 7.3.1-1A. For E-UTRA CA configurations including an operating band without uplink band (as noted in Table 5.5-1), the requirements for all downlinks shall be met with the single uplink carrier active in each band capable of UL operation. The requirements for the component carrier configured in the operating band without uplink band are specified in Table 7.6.1.1-1 and Table 7.6.1.1A-0.

Table 7.6.1.1A-0: In-band blocking for additional operating bands for carrier aggregation

E-UTRA band	Parameter	Unit	Case 1	Case 2
		$P_{\text{Interferer}}$	dBm	-56
	$F_{\text{Interferer}}$ (offset)	MHz	$= -BW/2 - F_{\text{offset, case 1}}$ & $= +BW/2 + F_{\text{offset, case 1}}$	$\leq -BW/2 - F_{\text{offset, case 2}}$ & $\geq +BW/2 + F_{\text{offset, case 2}}$
29, 32	$F_{\text{Interferer}}$	MHz	(Note 2)	$F_{\text{DL_low}} - 15$ to $F_{\text{DL_high}} + 15$
NOTE 1: For certain bands, the unwanted modulated interfering signal may not fall inside the UE receive band, but within the first 15 MHz below or above the UE receive band NOTE 2: For each carrier frequency the requirement is valid for two frequencies: a. the carrier frequency $-BW/2 - F_{\text{offset, case 1}}$ and b. the carrier frequency $+BW/2 + F_{\text{offset, case 1}}$ NOTE 3: $F_{\text{Interferer}}$ range values for unwanted modulated interfering signal are interferer center frequencies				

For E-UTRA CA configurations listed in Table 7.3.1A-0a under conditions for which reference sensitivity for the operating band being tested is N/A, the in-band blocking requirements of subclause 7.6.1.1A do not apply.

For intra-band contiguous carrier aggregation the downlink SCC(s) shall be configured at nominal channel spacing to the PCC. For FDD, the PCC shall be configured closest to the uplink band. All downlink carriers shall be active throughout the test. The uplink output power shall be set as specified in Table 7.6.1.1A-1 with the uplink configuration set according to Table 7.3.1A-1 for the applicable carrier aggregation configuration. For UE(s) supporting one uplink carrier, the uplink configuration of the PCC shall be in accordance with Table 7.3.1-2. The UE shall fulfil the minimum requirement in presence of an interfering signal specified in Tables 7.6.1.1A-1 and Tables 7.6.1.1A-2 being on either side of the aggregated signal. The throughput of each carrier shall be $\geq 95\%$ of the maximum throughput of the reference measurement channels as specified in Annexes A.2.2, A.2.3 and A.3.2 (with one sided dynamic OCNG Pattern OP.1 FDD/TDD for the DL-signal as described in Annex A.5.1.1/A.5.2.1) with parameters specified in Tables 7.6.1.1A-1 and 7.6.1.1A-2.

For intra-band non-contiguous carrier aggregation with one uplink carrier and two downlink sub-blocks, each larger than or equal to 5 MHz, the in-band blocking requirements are defined with the uplink configuration in accordance with Table 7.3.1A-3. For this uplink configuration, the UE shall meet the requirements for each sub-block as specified in subclause 7.6.1.1 and in this subclause for one component carrier and two component carriers per sub-block, respectively. The requirements apply for in-gap and out-of-gap interferers while all downlink carriers are active.

Table 7.6.1.1A-1: In band blocking parameters

Rx Parameter	Units	CA Bandwidth Class				
		B	C	D	E	F
Pw in Transmission Bandwidth Configuration, per CC	dBm	REFSENS + CA Bandwidth Class specific value below				
		9	12	13.8		
BW _{Interferer}	MHz	5	5	5		
F _{offset, case 1}	MHz	7.5	7.5	7.5		
F _{offset, case 2}	MHz	12.5	12.5	12.5		
NOTE 1: The transmitter shall be set to 4dB below P _{C_{MAX}L,c} or P _{C_{MAX}L} as defined in subclause 6.2.5A						
NOTE 2: The interferer consists of the Reference measurement channel specified in Annex A.3.2 with one sided dynamic OCNG Pattern OP.1 FDD/TDD as described in Annex A.5.1.1/A.5.2.1 and set-up according to Annex C.3.1						

Table 7.6.1.1A-2: In-band blocking

CA configuration	Parameter	Unit	Case 1	Case 2
		P _{Interferer}	dBm	-56
	F _{Interferer} (offset)	MHz	$= -F_{offset} - F_{offset, case 1}$ & $= +F_{offset} + F_{offset, case 1}$	$\leq -F_{offset} - F_{offset, case 2}$ & $\geq +F_{offset} + F_{offset, case 2}$
CA_1C, CA_2C, CA_3C, CA_7C, CA_12B, CA_23B, CA_27B, CA_38C, CA_39C, CA_40C, CA_41C, CA_40D, CA_41D, CA_42C	F _{Interferer} (Range)	MHz	(Note 2)	F _{DL_low} - 15 to F _{DL_high} + 15
NOTE 1: For certain bands, the unwanted modulated interfering signal may not fall inside the UE receive band, but within the first 15 MHz below or above the UE receive band				
NOTE 2: For each carrier frequency the requirement is valid for two frequencies: a. the carrier frequency $-F_{offset} - F_{offset, case 1}$ b. the carrier frequency $+F_{offset} + F_{offset, case 1}$				
NOTE 3: F _{offset} is the frequency offset from the center frequency of the CC being tested to the edge of aggregated channel bandwidth.				
NOTE 4: The F _{Interferer} (offset) is the frequency separation of the center frequency of the carrier closest to the interferer and the center frequency of the interferer and shall be further adjusted to $\lfloor F_{interferer} / 0.015 + 0.5 \rfloor 0.015 + 0.0075$ MHz to be offset from the sub-carrier raster.				

For combinations of intra-band contiguous and inter-band carrier aggregation with three downlink carriers and one uplink carrier assigned to one E-UTRA band, the requirement is defined with the uplink active in the band other than that supporting the downlink(s) under test and a configuration in accordance with Table 7.3.1-2. The downlink PCC carrier center frequency shall be configured closer to the uplink operating band than the downlink SCC center frequency when the uplink is active in the band supporting two component carriers. For E-UTRA CA configurations including an

operating band without uplink band, the requirements for all downlinks shall be met with the single uplink carrier active in each band capable of UL operation. For these uplink configurations, the UE shall meet the in-band blocking requirements for intra-band contiguous carrier aggregation of two downlink carriers and for the remaining component carrier the requirements specified in subclause 7.6.1. The three downlink carriers shall be active throughout the tests.

For combinations of intra-band non-contiguous and inter-band carrier aggregation with three downlink carriers and one uplink carrier assigned to one E-UTRA band, the requirement is defined with the uplink active in the band other than that supporting the downlink(s) under test. The uplink configuration shall be in accordance with Table 7.3.1A-3 when the uplink is active in the band supporting two component carriers and in accordance with Table 7.3.1-2 when the uplink is active in the other band. For E-UTRA CA configurations including an operating band without uplink band, the requirements for all downlinks shall be met with the single uplink carrier active in each band capable of UL operation. For these uplink configurations, the UE shall meet the in-band blocking requirements for intra-band non-contiguous carrier aggregation of two downlink carriers with $\Delta R_{IBNC} = 0$ dB for all sub-block gaps (Table 7.3.1A-3) and for the remaining component carrier the requirements specified in subclause 7.6.1. The three downlink carriers shall be active throughout the tests.

7.6.1.1D Minimum requirements for ProSe

The throughput shall be $\geq 95\%$ of the maximum throughput of the reference measurement channels as specified in Annex A.6.2.

Table 7.6.1.1D-1: In band blocking parameters for ProSe Direct Discovery

Rx parameter	Units	Channel bandwidth					
		1.4 MHz	3 MHz	5 MHz	10 MHz	15 MHz	20 MHz
Power in Transmission Bandwidth Configuration	dBm	P _{PREFSENS_ProSe} + channel bandwidth specific value below + P _{offset}					
				6	6	7	9
BW _{interferer}	MHz			5	5	5	5
F _{offset, case 1}	MHz			7.5+0.0125	7.5+0.0025	7.5+0.0075	7.5+0.0125
F _{offset, case 2}	MHz			12.5+0.0075	12.5+0.012	12.5+0.002	12.5+0.007
P _{offset}	dB			10.9	13.9	15.7	16.9
NOTE 1: The interferer is QPSK modulated PUSCH containing data and reference symbols. Normal cyclic prefix is used. The data content shall be uncorrelated to the wanted signal and modulated according to clause 5 of TS36.211							

Table 7.6.1.1D-2: In band blocking parameters for ProSe Direct Communication

Rx parameter	Units	Channel bandwidth					
		1.4 MHz	3 MHz	5 MHz	10 MHz	15 MHz	20 MHz
Power in Transmission Bandwidth Configuration	dBm	P _{PREFSENS_ProSe} + channel bandwidth specific value below					
				6	6	7	9
BW _{interferer}	MHz			5	5	5	5
F _{offset, case 1}	MHz			7.5+0.0125	7.5+0.0025	7.5+0.0075	7.5+0.0125
F _{offset, case 2}	MHz			12.5+0.0075	12.5+0.012	12.5+0.002	12.5+0.007
NOTE 1: The interferer is QPSK modulated PUSCH containing data and reference symbols. Normal cyclic prefix is used. The data content shall be uncorrelated to the wanted signal and modulated according to clause 5 of TS36.211							

Table 7.6.1.1D-3: In-band blocking for ProSe

E-UTRA ProSe band	Parameter	Unit	Case 1	Case 2
		$P_{\text{Interferer}}$	dBm	-56
	$F_{\text{Interferer}}$ (offset)	MHz	$=-BW/2 - F_{\text{offset, case 1}}$ & $=+BW/2 + F_{\text{offset, case 1}}$	$\leq -BW/2 - F_{\text{offset, case 2}}$ & $\geq +BW/2 + F_{\text{offset, case 2}}$
2,3,4,7,14,20,26,28,31	$F_{\text{Interferer}}$	MHz	(Note 2)	$F_{\text{DL_low}} - 15$ to $F_{\text{DL_high}} + 15$
NOTE 1: For certain bands, the unwanted modulated interfering signal may not fall inside the UE receive band, but within the first 15 MHz below or above the UE receive band				
NOTE 2: For each carrier frequency the requirement is valid for two frequencies: a. the carrier frequency $-BW/2 - F_{\text{offset, case 1}}$ and b. the carrier frequency $+BW/2 + F_{\text{offset, case 1}}$				
NOTE 3: $F_{\text{Interferer}}$ range values for unwanted modulated interfering signal are interferer center frequencies				

For the UE which supports inter band CA configuration in Table 7.3.1-1A, $P_{\text{Interferer}}$ power defined in Table 7.6.1.1D-3 is increased by the amount given by $\Delta R_{\text{IB,c}}$ in Table 7.3.1-1A.

7.6.2 Out-of-band blocking

Out-of-band band blocking is defined for an unwanted CW interfering signal falling more than 15 MHz below or above the UE receive band. For the first 15 MHz below or above the UE receive band the appropriate in-band blocking or adjacent channel selectivity in subclause 7.5.1 and subclause 7.6.1 shall be applied.

7.6.2.1 Minimum requirements

The throughput shall be $\geq 95\%$ of the maximum throughput of the reference measurement channels as specified in Annexes A.2.2, A.2.3 and A.3.2 (with one sided dynamic OCNG Pattern OP.1 FDD/TDD for the DL-signal as described in Annex A.5.1.1/A.5.2.1) with parameters specified in Tables 7.6.2.1-1 and 7.6.2.1-2.

For Table 7.6.2.1-2 in frequency range 1, 2 and 3, up to $\max(24, 6 \cdot \lceil N_{\text{RB}} / 6 \rceil)$ exceptions are allowed for spurious response frequencies in each assigned frequency channel when measured using a 1MHz step size, where N_{RB} is the number of resource blocks in the downlink transmission bandwidth configuration (see Figure 5.6-1). For these exceptions the requirements of subclause 7.7 Spurious response are applicable.

For Table 7.6.2.1-2 in frequency range 4, up to $\max(8, \lceil (N_{\text{RB}} + 2 \cdot L_{\text{CRBs}}) / 8 \rceil)$ exceptions are allowed for spurious response frequencies in each assigned frequency channel when measured using a 1MHz step size, where N_{RB} is the number of resource blocks in the downlink transmission bandwidth configurations (see Figure 5.6-1) and L_{CRBs} is the number of resource blocks allocated in the uplink. For these exceptions the requirements of clause 7.7 spurious response are applicable.

Table 7.6.2.1-1: Out-of-band blocking parameters

Rx Parameter	Units	Channel bandwidth					
		1.4 MHz	3 MHz	5 MHz	10 MHz	15 MHz	20 MHz
Power in Transmission Bandwidth Configuration	dBm	REFSENS + channel bandwidth specific value below					
		6	6	6	6	7	9
NOTE 1: The transmitter shall be set to 4dB below $P_{\text{CMAX,L}}$ at the minimum uplink configuration specified in Table 7.3.1-2 with $P_{\text{CMAX,L}}$ as defined in subclause 6.2.5.							
NOTE 2: Reference measurement channel is specified in Annex A.3.2 with one sided dynamic OCNG Pattern OP.1 FDD/TDD as described in Annex A.5.1.1/A.5.2.							

Table 7.6.2.1-2: Out of band blocking

E-UTRA band	Parameter	Units	Frequency			
			Range 1	Range 2	Range 3	Range 4
	$P_{\text{Interferer}}$	dBm	-44	-30	-15	-15
1, 2, 3, 4, 5, 6, 7, 8, 9, 10, 11, 12, 13, 14, 17, 18, 19, 20, 21, 22, 23, 24, 25, 26, 27, 28, 30, 31, 33, 34, 35, 36, 37, 38, 39, 40, 41, 42 (NOTE 2), 43 (NOTE 2), 44	$F_{\text{Interferer}}$ (CW)	MHz	$F_{\text{DL_low}} -15$ to $F_{\text{DL_low}} -60$	$F_{\text{DL_low}} -60$ to $F_{\text{DL_low}} -85$	$F_{\text{DL_low}} -85$ to 1 MHz	-
			$F_{\text{DL_high}} +15$ to $F_{\text{DL_high}} + 60$	$F_{\text{DL_high}} +60$ to $F_{\text{DL_high}} +85$	$F_{\text{DL_high}} +85$ to +12750 MHz	-
2, 5, 12, 17	$F_{\text{Interferer}}$	MHz	-	-	-	$F_{\text{UL_low}} - F_{\text{UL_high}}$
NOTE 1: For the UE which supports both Band 11 and Band 21 the out of blocking is FFS.						
NOTE 2: The power level of the interferer ($P_{\text{Interferer}}$) for Range 3 shall be modified to -20 dBm for $F_{\text{Interferer}} > 2800$ MHz and $F_{\text{Interferer}} < 4400$ MHz.						

7.6.2.1A Minimum requirements for CA

For inter-band carrier aggregation with one component carrier per operating band and the uplink assigned to one E-UTRA band, the out-of-band blocking requirements are defined with the uplink active on the band(s) other than the band whose downlink is being tested. The throughput in the downlink measured shall be $\geq 95\%$ of the maximum throughput of the reference measurement channels as specified in Annexes A.2.2, A.2.3 and A.3.2 (with one sided dynamic OCNG Pattern OP.1 FDD/TDD for the DL-signal as described in Annex A.5.1.1/A.5.2.1) with parameters specified in Tables 7.6.2.1-1 and 7.6.2.1A-0. The UE shall meet these requirements for each component carrier while all downlink carriers are active.

For inter-band carrier aggregation with one component carrier per operating band and the uplink active in two E-UTRA bands, the out-of-band blocking requirements specified above shall be met with the transmitter power for the uplink set to 7 dB below $P_{\text{CMAX}_L,c}$ for each serving cell c .

For E-UTRA CA configurations including an operating band without uplink band (as noted in Table 5.5-1), the requirements for all downlinks shall be met with the single uplink carrier active in each band capable of UL operation. For E-UTRA CA configurations listed in Table 7.3.1A-0a under conditions for which reference sensitivity for the operating band being tested is N/A, the out-of-band blocking requirements of subclause 7.6.2.1A do not apply.

Table 7.6.2.1A-0: out-of-band blocking for inter-band carrier aggregation

Parameter	Unit	Range 1	Range 2	Range 3
P_w	dBm	Table 7.6.2.1-1 for all component carriers		
$P_{interferer}$	dBm	$-44 + \Delta R_{IB,c}$	$-30 + \Delta R_{IB,c}$	$-15 + \Delta R_{IB,c}$
$F_{interferer}$ (CW)	MHz	$-60 < f - F_{DL_Low(j)} < -15$ or $15 < f - F_{DL_High(j)} < 60$	$-85 < f - F_{DL_Low(j)} \leq -60$ or $60 \leq f - F_{DL_High(j)} < 85$	$1 \leq f \leq F_{DL_Low(1)} - 85$ or $F_{DL_High(j)} + 85 \leq f \leq F_{DL_Low(j+1)} - 85$ with $j < X$ or $F_{DL_High(X)} + 85 \leq f \leq 12750$
<p>NOTE 1: $F_{DL_Low(j)}$ and $F_{DL_High(j)}$ denote the respective lower and upper frequency limits of the operating band containing carrier j, $j = 1, \dots, X$, with carriers numbered in increasing order of carrier frequency and X the number of component carriers in the band combination ($X = 2$ or $X = 3$ for the present version of this specification).</p> <p>NOTE 2: For $F_{DL_Low(j+1)} - F_{DL_High(j)} < 145$ MHz and $F_{interferer}$ in $F_{DL_High(j)} < f < F_{DL_Low(j+1)}$ with $j < X$, $F_{interferer}$ can be in both Range 1 and Range 2. Then the lower of the $P_{interferer}$ applies.</p> <p>NOTE 3: For $F_{DL_Low(j)} - 15$ MHz $\leq f \leq F_{DL_High(j)} + 15$ MHz the appropriate adjacent channel selectivity and in-band blocking requirements in the respective subclauses 7.5.1A and 7.6.1.1A shall be applied for carrier j.</p> <p>NOTE 4: $\Delta R_{IB,c}$ according to Table 7.3.1-1A applies when serving cell c is measured.</p> <p>NOTE 5: For inter-band CA combinations containing Bands 42 or 43, the interferer with respect to Band 42 or Band 43 shall have power level ($P_{interferer}$) for Range 3 modified to $-20 + \Delta R_{IB,c}$ dBm for $F_{interferer} > 2800$ MHz and $F_{interferer} < 4400$ MHz.</p>				

For Table 7.6.2.1A-0 in frequency ranges 1, 2 and 3, up to $\max(24,6 \cdot \lceil N_{RB} / 6 \rceil)$ exceptions per downlink are allowed for spurious response frequencies for one active uplink when measured using a step size of 1 MHz.

For Table 7.6.2.1A-0 in frequency ranges 1, 2 and 3, up to $2 \cdot \max(24,6 \cdot \lceil N_{RB} / 6 \rceil)$ exceptions per downlink are allowed for spurious response frequencies for two active uplinks when measured using a step size of 1 MHz. For these exceptions the requirements in clause 7.7.1A apply.

For intra-band contiguous carrier aggregations the downlink SCC(s) shall be configured at nominal channel spacing to the PCC. For FDD, the PCC shall be configured closest to the uplink band. All downlink carriers shall be active throughout the test. The uplink output power shall be set as specified in Table 7.6.2.1A-1 with the uplink configuration set according to Table 7.3.1A-1 for the applicable carrier aggregation configuration. For UE(s) supporting one uplink carrier, the uplink configuration of the PCC shall be in accordance with Table 7.3.1-2.

The UE shall fulfil the minimum requirement in presence of an interfering signal specified in Tables 7.6.2.1A-1 and Tables 7.6.2.1A-2 being on either side of the aggregated signal. The throughput of each carrier shall be $\geq 95\%$ of the maximum throughput of the reference measurement channels as specified in Annexes A.2.2, A.2.3 and A.3.2 (with one sided dynamic OCNG Pattern OP.1 FDD/TDD for the DL-signal as described in Annex A.5.1.1/A.5.2.1) with parameters specified in Tables 7.6.2.1A-1 and 7.6.2.1A-2.

For Table 7.6.2.1A-2 in frequency range 1, 2 and 3, up to $\max(24,6 \cdot \lceil N_{RB} / 6 \rceil)$ exceptions are allowed for spurious response frequencies in each assigned frequency channel when measured using a 1MHz step size. For these exceptions the requirements of subclause 7.7 Spurious response are applicable.

Table 7.6.2.1A-1: Out-of-band blocking parameters

Rx Parameter	Units	CA Bandwidth Class				
		B	C	D	E	F
P_w in Transmission Bandwidth Configuration, per CC	dBm	REFSENS + CA Bandwidth Class specific value below				
		9	9	9		
NOTE 1: The transmitter shall be set to 4dB below $P_{C_{MAX_L,c}}$ or $P_{C_{MAX_L}}$ as defined in subclause 6.2.5A.						
NOTE 2: Reference measurement channel is specified in Annex A.3.2 with one sided dynamic OCNG Pattern OP.1 FDD/TDD as described in Annex A.5.1.1/A.5.2.						

Table 7.6.2.1A-2: Out of band blocking

CA configuration	Parameter	Units	Frequency		
			Range 1	Range 2	Range 3
			-44	-30	-15
CA_1C, CA_2C, CA_3C, CA_7C, CA_12B, CA_23B, CA_27B, CA_38C, CA_39C, CA_40C, CA_41C, CA_40D, CA_42C (NOTE 1)	$P_{\text{Interferer}}$	dBm	$F_{\text{DL_low}} - 15$ to $F_{\text{DL_low}} - 60$	$F_{\text{DL_low}} - 60$ to $F_{\text{DL_low}} - 85$	$F_{\text{DL_low}} - 85$ to 1 MHz
	$F_{\text{Interferer}}$ (CW)	MHz	$F_{\text{DL_high}} + 15$ to $F_{\text{DL_high}} + 60$	$F_{\text{DL_high}} + 60$ to $F_{\text{DL_high}} + 85$	$F_{\text{DL_high}} + 85$ to +12750 MHz
NOTE 1: For CA_42C, the power level of the interferer ($P_{\text{Interferer}}$) for Range 3 shall be modified to -20 dBm for $F_{\text{Interferer}} > 2800$ MHz and $F_{\text{Interferer}} < 4400$ MHz.					

For intra-band non-contiguous carrier aggregation with one uplink carrier and two downlink sub-blocks, the out-of-band blocking requirements are defined with the uplink configuration in accordance with table 7.3.1A-3. For this uplink configuration, the UE shall meet the requirements for each sub-block as specified in subclauses 7.6.2.1 and 7.6.2.1A for one component carrier and two component carriers per sub-block, respectively. The requirements apply with all downlink carriers active.

For Table 7.6.2.1-2 in frequency range 1, 2 and 3, up to $\max(24,6 \cdot \lceil N_{RB} \cdot /6 \rceil)$ exceptions per assigned E-UTRA channel per sub-block of the E-UTRA CA configuration are allowed for spurious response frequencies for one active uplink when measured using a 1MHz step size. For these exceptions the requirements of subclause 7.7 spurious response are applicable.

For Table 7.6.2.1-2 in frequency range 4, up to $\max(8, \lceil (N_{RB} + 2 \cdot L_{CRBs}) /8 \rceil)$ exceptions per assigned E-UTRA channel per sub-block of the E-UTRA CA configuration are allowed for spurious response frequencies for one active uplink when measured using a 1MHz step size. For these exceptions the requirements of clause 7.7 spurious response are applicable.

For intra-band non-contiguous carrier aggregation with two uplink carriers and two downlink carriers, the out-of-band blocking requirements are defined with the uplink configuration of the PCC and SCC being in accordance with Table 7.3.1A-4 and powers of both carriers set to $P_{\text{CMAX_L,c}} - 7$ dBm. The UE shall meet the requirements specified in subclause 7.6.2.1 for each component carrier while both downlink carriers are active.

For Table 7.6.2.1-2 in frequency range 1, 2 and 3, up to $2 \cdot \max(24,6 \cdot \lceil N_{RB} \cdot /6 \rceil)$ exceptions per assigned E-UTRA channel per sub-block of the E-UTRA CA configuration are allowed for spurious response frequencies for two active uplinks in the same operating band when measured using a 1MHz step size. For these exceptions the requirements of subclause 7.7 spurious response are applicable.

For Table 7.6.2.1-2 in frequency range 4, up to $2 \cdot \max(8, \lceil (N_{RB} + 2 \cdot L_{CRBs}) /8 \rceil)$ exceptions per assigned E-UTRA channel per sub-block of the E-UTRA CA configuration are allowed for spurious response frequencies for two active uplinks in the same operating band when measured using a 1MHz step size. For these exceptions the requirements of clause 7.7 spurious response are applicable.

For combinations of intra-band contiguous and inter-band carrier aggregation with three downlink carriers and the uplink assigned to one E-UTRA band, the requirement is defined with the uplink active in the band other than that supporting the downlink(s) under test and a configuration in accordance with Table 7.3.1-2. The downlink PCC carrier center frequency shall be configured closer to the uplink operating band than the downlink SCC center frequency when the uplink is active in the band supporting two component carriers. For E-UTRA CA configurations including an operating band without uplink band, the requirements for all downlinks shall be met with the single uplink carrier active in each band capable of UL operation. For each downlink the UE shall meet the out-of-band blocking requirements applicable for inter-band carrier aggregation with one component carrier per operating band but with a sub-block of up to two component carriers assigned to the same operating band. For the sub-block of two component carriers the out-of-band blocking parameters in Table 7.6.2.1-1 are replaced by those specified in Table 7.6.2.1A-1. The three downlink carriers shall be active throughout the tests.

For combinations of intra-band non-contiguous and inter-band carrier aggregation with three downlink carriers and the uplink assigned to one E-UTRA band, the requirement is defined with the uplink active in the band other than that supporting the downlink(s) under test. The uplink configuration shall be in accordance with Table 7.3.1A-3 when the

uplink is active in the band supporting two component carriers and in accordance with Table 7.3.1-2 when the uplink is active in the other band. For E-UTRA CA configurations including an operating band without uplink band, the requirements for all downlinks shall be met with the single uplink carrier active in each band capable of UL operation. For the two component carriers within the same band, P_{wanted} in Table 7.6.2.1A-0 is set using $\Delta R_{\text{IBNC}} = 0$ dB for all sub-block gaps (Table 7.3.1A-3). For each downlink the UE shall meet the out-of-band blocking requirements applicable for inter-band carrier aggregation with one component carrier per operating band but with up to two component carriers assigned to the same band. The three downlink carriers shall be active throughout the tests.

7.6.2.1D Minimum requirements for ProSe

The throughput shall be $\geq 95\%$ of the maximum throughput of the reference measurement channels as specified in Annex A.6.2 with parameters specified in Tables 7.6.2.1D-1, 7.6.2.1D-2 and 7.6.2.1D-3.

For Table 7.6.2.1D-3 in frequency range 1, 2 and 3, up to $\max(24, 6 \cdot \lceil N_{\text{RB}} / 6 \rceil)$ exceptions are allowed for spurious response frequencies in each assigned frequency channel when measured using a 1MHz step size, where N_{RB} is the number of resource blocks in the downlink transmission bandwidth configuration (see Figure 5.6-1). For these exceptions the requirements of subclause 7.7 Spurious response are applicable.

Table 7.6.2.1D-1: Out-of-band blocking parameters for ProSe Direct Discovery

Rx Parameter	Units	Channel bandwidth					
		1.4 MHz	3 MHz	5 MHz	10 MHz	15 MHz	20 MHz
Power in Transmission Bandwidth Configuration	dBm	P _{REFSENS_ProSe} + channel bandwidth specific value below + P _{offset}					
				6	6	7	9
P _{offset}	dB			10.9	13.9	15.7	16.9

NOTE 2: Reference measurement channel is specified in Annex A.6.2.

Table 7.6.2.1D-2: Out-of-band blocking parameters for ProSe Direct Communication

Rx Parameter	Units	Channel bandwidth					
		1.4 MHz	3 MHz	5 MHz	10 MHz	15 MHz	20 MHz
Power in Transmission Bandwidth Configuration	dBm	P _{REFSENS_ProSe} + channel bandwidth specific value below					
				6	6	7	9

NOTE 1: Reference measurement channel is specified in Annex A.6.2.

Table 7.6.2.1D-3: Out of band blocking for ProSe

E-UTRA ProSe band	Parameter	Units	Frequency		
			Range 1	Range 2	Range 3
	P _{Interferer}	dBm	-44	-30	-15
2,3,4,7,14, 20,26,28,31	F _{Interferer} (CW)	MHz	F _{DL_low} -15 to F _{DL_low} -60	F _{DL_low} -60 to F _{DL_low} -85	F _{DL_low} -85 to 1 MHz
			F _{DL_high} +15 to F _{DL_high} +60	F _{DL_high} +60 to F _{DL_high} +85	F _{DL_high} +85 to +12750 MHz

NOTE 1: For the UE which supports both Band 11 and Band 21 the out of blocking is FFS.

7.6.3 Narrow band blocking

This requirement is measure of a receiver's ability to receive a E-UTRA signal at its assigned channel frequency in the presence of an unwanted narrow band CW interferer at a frequency, which is less than the nominal channel spacing.

7.6.3.1 Minimum requirements

The relative throughput shall be $\geq 95\%$ of the maximum throughput of the reference measurement channels as specified in Annexes A.2.2, A.2.3 and A.3.2 (with one sided dynamic OCNG Pattern OP.1 FDD/TDD for the DL-signal as described in Annex A.5.1.1/A.5.2.1) with parameters specified in Table 7.6.3.1-1

Table 7.6.3.1-1: Narrow-band blocking

Parameter	Unit	Channel Bandwidth					
		1.4 MHz	3 MHz	5 MHz	10 MHz	15 MHz	20 MHz
P_w	dBm	P_{REFSENS} + channel-bandwidth specific value below					
		22	18	16	13	14	16
$P_{\text{UW}}(\text{CW})$	dBm	-55	-55	-55	-55	-55	-55
F_{UW} (offset for $\Delta f = 15$ kHz)	MHz	0.9075	1.7025	2.7075	5.2125	7.7025	10.2075
F_{UW} (offset for $\Delta f = 7.5$ kHz)	MHz						
NOTE 1: The transmitter shall be set a 4 dB below $P_{\text{CMAX,L}}$ at the minimum uplink configuration specified in Table 7.3.1-2 with $P_{\text{CMAX,L}}$ as defined in subclause 6.2.5.							
NOTE 2: Reference measurement channel is specified in Annex A.3.2 with one sided dynamic OCNG Pattern OP.1 FDD/TDD as described in Annex A.5.1.1/A.5.2.1.							

For the UE which supports inter-band CA configuration in Table 7.3.1-1A, P_{UW} power defined in Table 7.6.3.1-1 is increased by the amount given by $\Delta R_{\text{IB,c}}$ in Table 7.3.1-1A.

7.6.3.1A Minimum requirements for CA

For inter-band carrier aggregation with one component carrier per operating band and the uplink assigned to one E-UTRA band the narrow-band blocking requirements are defined with the uplink active on the band(s) other than the band whose downlink is being tested. The UE shall meet the requirements specified in subclause 7.6.3.1 for each component carrier while all downlink carriers are active. For E-UTRA CA configurations including an operating band without uplink band (as noted in Table 5.5-1), the requirements for all downlinks shall be met with the single uplink carrier active in each band capable of UL operation. For E-UTRA CA configurations listed in Table 7.3.1A-0a under conditions for which reference sensitivity for the operating band being tested is N/A, the narrow-band blocking requirements of subclause 7.6.3.1A do not apply.

For intra-band contiguous carrier aggregation the downlink SCC(s) shall be configured at nominal channel spacing to the PCC. For FDD, the PCC shall be configured closest to the uplink band. All downlink carriers shall be active throughout the test. The uplink output power shall be set as specified in Table 7.6.3.1A-1 with the uplink configuration set according to Table 7.3.1A-1 for the applicable carrier aggregation configuration. For UE(s) supporting one uplink, the uplink configuration of the PCC shall be in accordance with Table 7.3.1-2. The UE shall fulfil the minimum requirement in presence of an interfering signal specified in Table 7.6.3.1A-1 being on either side of the aggregated signal. The throughput of each carrier shall be $\geq 95\%$ of the maximum throughput of the reference measurement channels as specified in Annexes A.2.2, A.2.3 and A.3.2 (with one sided dynamic OCNG Pattern OP.1 FDD/TDD for the DL-signal as described in Annex A.5.1.1/A.5.2.1) with parameters specified in Table 7.6.3.1A-1.

For intra-band non-contiguous carrier aggregation with one uplink carrier and two downlink sub-blocks, the narrow band blocking requirements are defined with the uplink configuration in accordance with Table 7.3.1A-3. For this uplink configuration, the UE shall meet the requirements for each sub-block as specified in subclauses 7.6.3.1 and 7.6.3.1A for one component carrier and two component carriers per sub-block, respectively. The requirements apply for in-gap and out-of-gap interferers while all downlink carriers are active.

Table 7.6.3.1A-1: Narrow-band blocking

Parameter	Unit	CA Bandwidth Class				
		B	C	D	E	F
P_w in Transmission Bandwidth Configuration, per CC	dBm	REFSENS + CA Bandwidth Class specific value below				
		16	16 ⁴	16		
P_{uw} (CW)	dBm	-55	-55	-55		
F_{uw} (offset for $\Delta f = 15$ kHz)		MHz	- $F_{offset} - 0.2$ / + $F_{offset} + 0.2$	- $F_{offset} - 0.2$ / + $F_{offset} + 0.2$	- $F_{offset} - 0.2$ / + $F_{offset} + 0.2$	
F_{uw} (offset for $\Delta f = 7.5$ kHz)	MHz					
NOTE 1: The transmitter shall be set to 4dB below $P_{CMAX,L,c}$ or $P_{CMAX,L}$ as defined in subclause 6.2.5A.						
NOTE 2: Reference measurement channel is specified in Annex A.3.2 with one sided dynamic OCNG Pattern OP.1 FDD/TDD as described in Annex A.5.1.1/A.5.2.1.						
NOTE 3: The F_{uw} (offset) is the frequency separation of the center frequency of the carrier closest to the interferer and the center frequency of the interferer and shall be further adjusted to $\lfloor F_{interferer} / 0.015 + 0.5 \rfloor 0.015 + 0.0075$ MHz to be offset from the sub-carrier raster.						
NOTE 4: The requirement is applied for the band combinations whose component carriers' BW ≥ 5 MHz.						

For combinations of intra-band contiguous and inter-band carrier aggregation with three downlink carriers and one uplink carrier assigned to one E-UTRA band, the requirement is defined with the uplink active in the band other than that supporting the downlink(s) under test and a configuration in accordance with Table 7.3.1-2. The downlink PCC carrier center frequency shall be configured closer to the uplink operating band than the downlink SCC center frequency when the uplink is active in the band supporting two component carriers. For E-UTRA CA configurations including an operating band without uplink band, the requirements for all downlinks shall be met with the single uplink carrier active in each band capable of UL operation. For these uplink configurations, the UE shall meet the narrow-band blocking requirements for intra-band contiguous carrier aggregation of two downlink carriers and for the remaining component carrier the requirements specified in subclause 7.6.3. The three downlink carriers shall be active throughout the tests.

For combinations of intra-band non-contiguous and inter-band carrier aggregation with three downlink carriers and one uplink carrier assigned to one E-UTRA band, the requirement is defined with the uplink active in the band other than that supporting the downlink(s) under test. The uplink configuration shall be in accordance with Table 7.3.1A-3 when the uplink is active in the band supporting two component carriers and in accordance with Table 7.3.1-2 when the uplink is active in the other band. For E-UTRA CA configurations including an operating band without uplink band, the requirements for all downlinks shall be met with the single uplink active in each band capable of UL operation. For these uplink configurations, the UE shall meet the narrow-band blocking requirements for intra-band non-contiguous carrier aggregation of two downlink carriers with $\Delta R_{IBNC} = 0$ dB for all sub-block gaps (Table 7.3.1A-3) and for the remaining component carrier the requirements specified in subclause 7.6.3. The three downlink carriers shall be active throughout the tests.

7.6.3.1D Minimum requirements for ProSe

The relative throughput shall be $\geq 95\%$ of the maximum throughput of the reference measurement channels as specified in Annex A.6.2 with parameters specified in Table 7.6.3.1D-1 and Table 7.6.3.1D-2.

Table 7.6.3.1D-1: Narrow-band blocking for ProSe Direct Discovery

Parameter	Unit	Channel Bandwidth					
		1.4 MHz	3 MHz	5 MHz	10 MHz	15 MHz	20 MHz
P_w	dBm	PRESENS _{ProSe} + channel-bandwidth specific value below + P_{offset}					
				16	13	14	16
P_{uw} (CW)	dBm			-55	-55	-55	-55
P_{offset}		dB			10.9	13.9	15.7
F_{uw} (offset for $\Delta f = 15$ kHz)	MHz			2.7075	5.2125	7.7025	10.2075
F_{uw} (offset for $\Delta f = 7.5$ kHz)		MHz					
NOTE 1: Reference measurement channel is specified in Annex A.6.2.							

Table 7.6.3.1D-2: Narrow-band blocking for ProSe Direct Communication

Parameter	Unit	Channel Bandwidth					
		1.4 MHz	3 MHz	5 MHz	10 MHz	15 MHz	20 MHz
P_w	dBm	$P_{\text{REFSENS_ProSe}}$ + channel-bandwidth specific value below					
				16	13	14	16
$P_{\text{UW}}(\text{CW})$	dBm			-55	-55	-55	-55
F_{UW} (offset for $\Delta f = 15$ kHz)	MHz			2.7075	5.2125	7.7025	10.2075
F_{UW} (offset for $\Delta f = 7.5$ kHz)	MHz						

NOTE 1: Reference measurement channel is specified in Annex A.6.2.

For the UE which supports inter-band CA configuration in Table 7.3.1-1A, P_{UW} power defined in Table 7.6.3.1D-1 and Table 7.6.3.1D-2 is increased by the amount given by $\Delta R_{\text{IB,c}}$ in Table 7.3.1-1A.

7.6A Void

<Reserved for future use>

7.6B Blocking characteristics for UL-MIMO

For UE with two transmitter antenna connectors in closed-loop spatial multiplexing scheme, the minimum requirements in subclause 7.6 shall be met with the UL-MIMO configurations specified in Table 6.2.2B-2. For UL-MIMO, the parameter $P_{\text{CMAX_L}}$ is defined as the total transmitter power over the two transmit antenna connectors.

7.7 Spurious response

Spurious response is a measure of the receiver's ability to receive a wanted signal on its assigned channel frequency without exceeding a given degradation due to the presence of an unwanted CW interfering signal at any other frequency at which a response is obtained i.e. for which the out of band blocking limit as specified in subclause 7.6.2 is not met.

7.7.1 Minimum requirements

The throughput shall be $\geq 95\%$ of the maximum throughput of the reference measurement channels as specified in Annexes A.2.2, A.2.3 and A.3.2 (with one sided dynamic OCNB Pattern OP.1 FDD/TDD for the DL-signal as described in Annex A.5.1.1/A.5.2.1) with parameters specified in Tables 7.7.1-1 and 7.7.1-2.

Table 7.7.1-1: Spurious response parameters

Rx parameter	Units	Channel bandwidth					
		1.4 MHz	3 MHz	5 MHz	10 MHz	15 MHz	20 MHz
Power in Transmission Bandwidth Configuration	dBm	REFSENS + channel bandwidth specific value below					
		6	6	6	6	7	9

NOTE 1: The transmitter shall be set to 4dB below $P_{\text{CMAX_L}}$ at the minimum uplink configuration specified in Table 7.3.1-2.

NOTE 2: Reference measurement channel is specified in Annex A.3.2 with one sided dynamic OCNB Pattern OP.1 FDD/TDD as described in Annex A.5.1.1/A.5.2.1.

Table 7.7.1-2: Spurious response

Parameter	Unit	Level
$P_{\text{Interferer}}(\text{CW})$	dBm	-44
$F_{\text{Interferer}}$	MHz	Spurious response frequencies

For the UE which supports inter-band CA configuration in Table 7.3.1-1A, $P_{\text{interferer}}$ power defined in Table 7.7.1-2 is increased by the amount given by $\Delta R_{\text{IB,c}}$ in Table 7.3.1-1A.

7.7.1A Minimum requirements for CA

For inter-band carrier aggregation with one component carrier per operating band and the uplink assigned to one E-UTRA band the spurious response requirements are defined with the uplink active on the band(s) other than the band whose downlink is being tested. The throughput measured in each downlink with $F_{\text{interferer}}$ in Table 7.6.2.1A-0 at spurious response frequencies shall be $\geq 95\%$ of the maximum throughput of the reference measurement channels as specified in Annexes A.2.2, A.2.3 and A.3.2 (with one sided dynamic OCNG Pattern OP.1 FDD/TDD for the DL-signal as described in Annex A.5.1.1/A.5.2.1) with parameters specified in Tables 7.7.1-1 and 7.7.1-2. The UE shall meet these requirements for each component carrier while all downlink carriers are active.

For inter-band carrier aggregation with one component carrier per operating band and the uplink active in two E-UTRA bands, the spurious response requirements applicable specified above shall be met with the transmitter power for the uplink set to 7 dB below $P_{\text{CMAX,L,c}}$ for each serving cell c .

For E-UTRA CA configurations including an operating band without uplink band (as noted in Table 5.5-1), the requirements for all downlinks shall be met with the single uplink carrier active in each band capable of UL operation. For E-UTRA CA configurations listed in Table 7.3.1A-0a under conditions for which reference sensitivity for the operating band being tested is N/A, the spurious response requirements of subclause 7.7.1A do not apply.

For intra-band contiguous carrier aggregation the downlink SCC(s) shall be configured at nominal channel spacing to the PCC. For FDD, the PCC shall be configured closest to the uplink band. All downlink carriers shall be active throughout the test. The uplink output power shall be set as specified in Table 7.7.1A-1 with the uplink configuration set according to Table 7.3.1A-1 for the applicable carrier aggregation configuration. For UE(s) supporting one uplink carrier, the uplink configuration of the PCC shall be in accordance with Table 7.3.1-2. The throughput of each carrier shall be $\geq 95\%$ of the maximum throughput of the reference measurement channels as specified in Annexes A.2.2, A.2.3 and A.3.2 (with one sided dynamic OCNG Pattern OP.1 FDD/TDD for the DL-signal as described in Annex A.5.1.1/A.5.2.1) with parameters specified in Tables 7.7.1A-1 and 7.7.1A-2.

For intra-band non-contiguous carrier aggregation with one uplink carrier and two downlink sub-blocks, the spurious response requirements are defined with the uplink configuration in accordance with Table 7.3.1A-3. For this uplink configuration, the UE shall meet the requirements for each sub-block as specified in subclauses 7.7.1 and 7.7.1A for one component carrier and two component carriers per sub-block, respectively. The requirements apply with all downlink carriers active.

For intra-band non-contiguous carrier aggregation with two uplink carriers and two downlink carriers, the spurious response requirements applicable specified above shall be met with the transmitter powers for the uplinks set to $P_{\text{CMAX,L,c}} - 7$ dBm.

Table 7.7.1A-1: Spurious response parameters

Rx Parameter	Units	CA Bandwidth Class				
		B	C	D	E	F
Pw in Transmission Bandwidth Configuration, per CC	dBm	REFSENS + CA Bandwidth Class specific value below				
		9	9	9		
NOTE 1: The transmitter shall be set to 4dB below $P_{\text{CMAX,L,c}}$ or $P_{\text{CMAX,L}}$ as defined in subclause 6.2.5A.						
NOTE 2: Reference measurement channel is specified in Annex A.3.2 with one sided dynamic OCNG Pattern OP.1 FDD/TDD as described in Annex A.5.1.1/A.5.2.1.						

Table 7.7.1A-2: Spurious response

Parameter	Unit	Level
$P_{\text{Interferer}}$ (CW)	dBm	-44
$F_{\text{Interferer}}$	MHz	Spurious response frequencies

For combinations of intra-band contiguous and inter-band carrier aggregation with three downlink carriers and one uplink carrier assigned to one E-UTRA band, the requirement is defined with the uplink active in the band other than that supporting the downlink(s) under test and a configuration in accordance with Table 7.3.1-2. The downlink PCC

carrier center frequency shall be configured closer to the uplink operating band than the downlink SCC center frequency when the uplink is active in the band supporting two component carriers. For E-UTRA CA configurations including an operating band without uplink band, the requirements for all downlinks shall be met with the single uplink carrier active in each band capable of UL operation. For each downlink the UE shall meet the spurious-response requirements applicable for inter-band carrier aggregation with one component carrier per operating band but with a sub-block of up to two component carriers assigned to the same operating band. For the sub-block of two component carriers the spurious response parameters in Table 7.7.1-1 are replaced by those specified in Table 7.7.1A-1. The three downlink carriers shall be active throughout the tests.

For combinations of intra-band non-contiguous and inter-band carrier aggregation with three downlink carriers and one uplink carrier assigned to one E-UTRA band, the requirement is defined with the uplink active in the band other than that supporting the downlink(s) under test. The uplink configuration shall be in accordance with Table 7.3.1A-3 when the uplink is active in the band supporting two component carriers and in accordance with Table 7.3.1-2 when the uplink is active in the other band. For E-UTRA CA configurations including an operating band without uplink band, the requirements for all downlinks shall be met with the single uplink carrier active in each band capable of UL operation. For the two component carriers within the same band, P_{wanted} in Table 7.6.2.1A-0 is set using $\Delta R_{\text{IBNC}} = 0$ dB for all sub-block gaps (Table 7.3.1A-3). For each downlink the UE shall meet the spurious-response requirements applicable for inter-band carrier aggregation with one component carrier per operating band but with up to two component carriers assigned to the same band. The three downlink carriers shall be active throughout the tests.

7.7.1B Minimum requirements for UL-MIMO

For UE with two transmitter antenna connectors in closed-loop spatial multiplexing scheme, the minimum requirements in Clause 7.7.1 shall be met with the UL-MIMO configurations specified in Table 6.2.2B-2. For UL-MIMO, the parameter $P_{\text{CMAX,L}}$ is defined as the total transmitter power over the two transmit antenna connectors.

7.7.1D Minimum requirements for ProSe

The throughput shall be $\geq 95\%$ of the maximum throughput of the reference measurement channels as specified in Annex A.6.2 with parameters specified in Tables 7.7.1D-1, 7.7.1D-2, and 7.7.1D-3.

Table 7.7.1D-1: Spurious response parameters for ProSe Direct Discovery

Rx parameter	Units	Channel bandwidth					
		1.4 MHz	3 MHz	5 MHz	10 MHz	15 MHz	20 MHz
Power in Transmission Bandwidth Configuration	dBm	$P_{\text{REFSENS_ProSe}} + \text{channel bandwidth specific value below} + P_{\text{Offset}}$					
				6	6	7	9
P_{Offset}	dB			10.9	13.9	15.7	16.9
NOTE 1: Reference measurement channel is specified in Annex A.6.2.							

Table 7.7.1D-2: Spurious response parameters for ProSe Direct Communication

Rx parameter	Units	Channel bandwidth					
		1.4 MHz	3 MHz	5 MHz	10 MHz	15 MHz	20 MHz
Power in Transmission Bandwidth Configuration	dBm	$P_{\text{REFSENS_ProSe}} + \text{channel bandwidth specific value below}$					
				6	6	7	9
NOTE 1: Reference measurement channel is specified in Annex A.6.2.							

Table 7.7.1D-3: Spurious response for ProSe

Parameter	Unit	Level
$P_{\text{Interferer (CW)}}$	dBm	-44
$F_{\text{Interferer}}$	MHz	Spurious response frequencies

For the UE which supports inter-band CA configuration in Table 7.3.1-1A, $P_{\text{interferer}}$ power defined in Table 7.7.1D-3 is increased by the amount given by $\Delta R_{\text{IB,c}}$ in Table 7.3.1-1A.

7.8 Intermodulation characteristics

Intermodulation response rejection is a measure of the capability of the receiver to receive a wanted signal on its assigned channel frequency in the presence of two or more interfering signals which have a specific frequency relationship to the wanted signal.

7.8.1 Wide band intermodulation

The wide band intermodulation requirement is defined following the same principles using modulated E-UTRA carrier and CW signal as interferer.

7.8.1.1 Minimum requirements

The throughput shall be $\geq 95\%$ of the maximum throughput of the reference measurement channels as specified in Annexes A.2.2, A.2.3 and A.3.2 (with one sided dynamic OCNG Pattern OP.1 FDD/TDD for the DL-signal as described in Annex A.5.1.1/A.5.2.1) with parameters specified in Table 7.8.1.1 for the specified wanted signal mean power in the presence of two interfering signals

Table 7.8.1.1-1: Wide band intermodulation

Rx Parameter	Units	Channel bandwidth					
		1.4 MHz	3 MHz	5 MHz	10 MHz	15 MHz	20 MHz
Power in Transmission Bandwidth Configuration	dBm	REFSENS + channel bandwidth specific value below					
		12	8	6	6	7	9
$P_{\text{Interferer 1}}$ (CW)	dBm	-46					
$P_{\text{Interferer 2}}$ (Modulated)	dBm	-46					
$BW_{\text{Interferer 2}}$		1.4	3	5			
$F_{\text{Interferer 1}}$ (Offset)	MHz	-BW/2 -2.1 / +BW/2+ 2.1	-BW/2 -4.5 / +BW/2 + 4.5	-BW/2 - 7.5 / +BW/2 + 7.5			
$F_{\text{Interferer 2}}$ (Offset)	MHz	$2 \cdot F_{\text{Interferer 1}}$					
NOTE 1: The transmitter shall be set to 4dB below $P_{\text{CMAX,L}}$ at the minimum uplink configuration specified in Table 7.3.1-2 with $P_{\text{CMAX,L}}$ as defined in subclause 6.2.5.							
NOTE 2: Reference measurement channel is specified in Annex A.3.2 with one sided dynamic OCNG Pattern OP.1 FDD/TDD as described in Annex A.5.1.1/A.5.2.1.							
NOTE 3: The modulated interferer consists of the Reference measurement channel specified in Annex A.3.2 with one sided dynamic OCNG Pattern OP.1 FDD/TDD as described in Annex A.5.1.1/A.5.2.1 with set-up according to Annex C.3.1The interfering modulated signal is 5MHz E-UTRA signal as described in Annex D for channel bandwidth $\geq 5\text{MHz}$							

For the UE which supports inter band CA configuration in Table 7.3.1-1A, $P_{\text{interferer1}}$ and $P_{\text{interferer2}}$ powers defined in Table 7.8.1.1-1 are increased by the amount given by $\Delta R_{\text{IB,c}}$ in Table 7.3.1-1A.

7.8.1A Minimum requirements for CA

For inter-band carrier aggregation with one component carrier per operating band and the uplink assigned to one E-UTRA band the wide band intermodulation requirements are defined with the uplink active on the band(s) other than the band whose downlink is being tested. The UE shall meet the requirements specified in subclause 7.8.1.1 for each component carrier while all downlink carriers are active. For E-UTRA CA configurations including an operating band without uplink band (as noted in Table 5.5-1), the requirements for all downlinks shall be met with the single uplink carrier active in each band capable of UL operation. For E-UTRA CA configurations listed in Table 7.3.1A-0a under conditions for which reference sensitivity for the operating band being tested is N/A, the wideband intermodulation requirements of subclause 7.8.1A do not apply.

For intra-band contiguous carrier aggregation the downlink SCC(s) shall be configured at nominal channel spacing to the PCC, For FDD, the PCC shall be configured closest to the uplink band. All downlink carriers shall be active throughout the test. The uplink output power shall be set as specified in Table 7.8.1A-1 with the uplink configuration set according to Table 7.3.1A-1 for the applicable carrier aggregation configuration. For UE(s) supporting one uplink carrier, the uplink configuration of the PCC shall be in accordance with Table 7.3.1-2. The UE shall fulfil the minimum requirement in presence of an interfering signal specified in Table 7.8.1A-1 being on either side of the aggregated signal. The throughput of each carrier shall be $\geq 95\%$ of the maximum throughput of the reference measurement channels as specified in Annexes A.2.2, A.2.3 and A.3.2 (with one sided dynamic OCNG Pattern OP.1 FDD/TDD for the DL-signal as described in Annex A.5.1.1/A.5.2.1) with parameters specified in Table 7.8.1A-1

Table 7.8.1A-1: Wide band intermodulation

Rx parameter	Units	CA Bandwidth Class				
		B	C	D	E	F
P _w in Transmission Bandwidth Configuration, per CC	dBm	REFSENS + CA Bandwidth Class specific value below				
		9	12	13.8		
P _{Interferer 1} (CW)	dBm	-46				
P _{Interferer 2} (Modulated)	dBm	-46				
BW _{Interferer 2}	MHz	5	5	5		
F _{Interferer 1} (Offset)	MHz	-F _{offset} -7.5 / + F _{offset} +7.5	-F _{offset} -7.5 / + F _{offset} +7.5	-F _{offset} -7.5 / + F _{offset} +7.5		
F _{Interferer 2} (Offset)	MHz	2*F _{Interferer 1}				
NOTE 1: The transmitter shall be set to 4dB below P _{CMAX,L,c} or P _{CMAX,L} as defined in subclause 6.2.5A.						
NOTE 2: Reference measurement channel is specified in Annex A.3.2 with one sided dynamic OCNG Pattern OP.1 FDD/TDD as described in Annex A.5.1.1/A.5.2.1.						
NOTE 3: The modulated interferer consists of the Reference measurement channel specified in Annex A.3.2 with one sided dynamic OCNG Pattern OP.1 FDD/TDD as described in Annex A.5.1.1/A.5.2.1 with set-up according to Annex C.3.1.						
NOTE 4: The interfering modulated signal is 5MHz E-UTRA signal as described in Annex D for channel bandwidth ≥ 5 MHz;						
NOTE 5: The F _{interferer 1} (offset) is the frequency separation of the center frequency of the carrier closest to the interferer and the center frequency of the CW interferer and F _{interferer 2} (offset) is the frequency separation of the center frequency of the carrier closest to the interferer and the center frequency of the modulated interferer.						

For intra-band non-contiguous carrier aggregation with one uplink carrier and two downlink sub-blocks, the wide band intermodulation requirements are defined with the uplink configuration in accordance with Table 7.3.1A-3. For this uplink configuration, the UE shall meet the requirements for each sub-block as specified in subclauses 7.8.1.1 and in this subclause for one component carrier and two component carriers per sub-block, respectively. The requirements apply for out-of-gap interferers while all downlink carriers are active.

For combinations of intra-band contiguous and inter-band carrier aggregation with three downlink carriers and one uplink carrier assigned to one E-UTRA band, the requirement is defined with the uplink active in the band other than that supporting the downlink(s) under test and a configuration in accordance with Table 7.3.1-2. The downlink PCC carrier center frequency shall be configured closer to the uplink operating band than the downlink SCC center frequency when the uplink is active in the band supporting two component carriers. For E-UTRA CA configurations including an operating band without uplink band, the requirements for all downlinks shall be met with the single uplink carrier active in each band capable of UL operation. For these uplink configurations, the UE shall meet the wide-band intermodulation requirements for intra-band contiguous carrier aggregation of two downlink carriers and for the remaining component carrier the requirements specified in subclause 7.8.1. The three downlink carriers shall be active throughout the tests.

For combinations of intra-band non-contiguous and inter-band carrier aggregation with three downlink carriers and one uplink carrier assigned to one E-UTRA band, the requirement is defined with the uplink active in the band other than that supporting the downlink(s) under test. The uplink configuration shall be in accordance with Table 7.3.1A-3 when the uplink is active in the band supporting two component carriers and in accordance with Table 7.3.1-2 when the uplink is active in the other band. For E-UTRA CA configurations including an operating band without uplink band, the

requirements for all downlinks shall be met with the single uplink carrier active in each band capable of UL operation. For these uplink configurations, the UE shall meet the wide-band intermodulation requirements for intra-band non-contiguous carrier aggregation of two downlink carriers with $\Delta R_{IBNC} = 0$ dB for all sub-block gaps (Table 7.3.1A-3) and for the remaining component carrier the requirements specified in subclause 7.8.1. The three downlink carriers shall be active throughout the tests.

7.8.1B Minimum requirements for UL-MIMO

For UE(s) with two transmitter antenna connectors in closed-loop spatial multiplexing scheme, the minimum requirements in subclause 7.8.1 shall be met with the UL-MIMO configurations specified in Table 6.2.2B-2. For UL-MIMO, the parameter $P_{\text{CMAX,L}}$ is defined as the total transmitter power over the two transmit antenna connectors.

7.8.1D Minimum requirements for ProSe

The throughput shall be $\geq 95\%$ of the maximum throughput of the reference measurement channels as specified in Annex A.6.2 with parameters specified in Table 7.8.1D-1, Table 7.8.1D-2, and Table 7.8.1D-3 for the specified wanted signal mean power in the presence of two interfering signals

Table 7.8.1D-1: Wide band intermodulation parameters for ProSe Direct Discovery

Rx parameter	Units	Channel bandwidth					
		1.4 MHz	3 MHz	5 MHz	10 MHz	15 MHz	20 MHz
P_{offset}	dB			10.9	13.9	15.7	16.9

Table 7.8.1D-2: Wide band intermodulation for ProSe Direct Communication

Rx parameter	Units	Channel bandwidth					
		1.4 MHz	3 MHz	5 MHz	10 MHz	15 MHz	20 MHz
P_{offset}	dB			0	0	0	0

Table 7.8.1D-3: Wide band intermodulation for ProSe

Rx Parameter	Units	Channel bandwidth					
		1.4 MHz	3 MHz	5 MHz	10 MHz	15 MHz	20 MHz
Power in Transmission Bandwidth Configuration	dBm	$P_{\text{REFSENS_ProSe}} + \text{channel bandwidth specific value below} + P_{\text{offset}}$					
		12	8	6	6	7	9
$P_{\text{Interferer 1 (CW)}}$	dBm	-46					
$P_{\text{Interferer 2 (Modulated)}}$	dBm	-46					
$BW_{\text{Interferer 2}}$		1.4	3	5			
$F_{\text{Interferer 1 (Offset)}}$	MHz	-BW/2 -2.1 / +BW/2+ 2.1	-BW/2 -4.5 / +BW/2 + 4.5	-BW/2 - 7.5 / +BW/2 + 7.5			
$F_{\text{Interferer 2 (Offset)}}$	MHz	$2 * F_{\text{Interferer 1}}$					
NOTE 1: Reference measurement channel is specified in Annex A.6.2							
NOTE 2: The interferer is QPSK modulated PUSCH containing data and reference symbols. Normal cyclic prefix is used. The data content shall be uncorrelated to the wanted signal and modulated according to clause 5 of TS36.211							

For the UE which supports inter band CA configuration in Table 7.3.1-1A, $P_{\text{interferer1}}$ and $P_{\text{interferer2}}$ powers defined in Table 7.8.1D-3 are increased by the amount given by $\Delta R_{IB,c}$ in Table 7.3.1-1A.

7.8.2 Void

7.9 Spurious emissions

The spurious emissions power is the power of emissions generated or amplified in a receiver that appear at the UE antenna connector.

7.9.1 Minimum requirements

The power of any narrow band CW spurious emission shall not exceed the maximum level specified in Table 7.9.1-1

Table 7.9.1-1: General receiver spurious emission requirements

Frequency band	Measurement bandwidth	Maximum level	Note
$30\text{MHz} \leq f < 1\text{GHz}$	100 kHz	-57 dBm	
$1\text{GHz} \leq f \leq 12.75\text{ GHz}$	1 MHz	-47 dBm	
$12.75\text{ GHz} \leq f \leq 5^{\text{th}}$ harmonic of the upper frequency edge of the DL operating band in GHz	1 MHz	-47 dBm	1
NOTE 1: Applies only for Band 22, Band 42 and Band 43			
NOTE 2: Unused PDCCH resources are padded with resource element groups with power level given by PDCCH_RA/RB as defined in Annex C.3.1.			

7.9.1A Minimum requirements

For E-UTRA CA configurations including an operating band without uplink band (as noted in Table 5.5-1), the power of any narrow band CW spurious emission shall not exceed the maximum level specified in Table 7.9.1A-1.

Table 7.9.1A-1: General receiver spurious emission requirements

Frequency band	Measurement bandwidth	Maximum level	Note
$30\text{MHz} \leq f < 1\text{GHz}$	100 kHz	-57 dBm	
$1\text{GHz} \leq f \leq 12.75\text{ GHz}$	1 MHz	-47 dBm	
NOTE 1: Unused PDCCH resources are padded with resource element groups with power level given by PDCCH_RA/RB as defined in Annex C.3.1.			
NOTE 2: The requirements apply when the UE is configured for carrier aggregation but is not transmitting.			

7.10 Receiver image

7.10.1 Void

7.10.1A Minimum requirements for CA

Receiver image rejection is a measure of a receiver's ability to receive the E-UTRA signal on one component carrier while it is also configured to receive an adjacent aggregated carrier. Receiver image rejection ratio is the ratio of the wanted received power on a sub-carrier being measured to the unwanted image power received on the same sub-carrier when both sub-carriers are received with equal power at the UE antenna connector.

For intra-band contiguous carrier aggregation the UE shall fulfil the minimum requirement specified in Table 7.10.1A-1 for all values of aggregated input signal up to -22 dBm.

Table 7.10.1A-1: Receiver image rejection

Rx parameter	Units	CA bandwidth class					
		A	B	C	D	E	F
Receiver image rejection	dB		25	25	25		

8 Performance requirement

This clause contains performance requirements for the physical channels specified in TS 36.211 [4]. The performance requirements for the UE in this clause are specified for the measurement channels specified in Annex A.3, the propagation conditions in Annex B and the downlink channels in Annex C.3.2.

Note: For the requirements in the following sections, similar Release 8 and 9 requirements apply for time domain measurements restriction under colliding CRS.

8.1 General

8.1.1 Receiver antenna capability

The performance requirements are based on UE(s) that utilize one or more antenna receivers.

For all test cases, the SNR is defined as

$$SNR = \frac{\sum_{j=1}^{N_{RX}} \hat{E}_s^{(j)}}{\sum_{j=1}^{N_{RX}} N_{oc}^{(j)}}$$

where N_{RX} denotes the number of receiver antenna connectors and the superscript receiver antenna connector j . The above SNR definition assumes that the REs are not precoded. The SNR definition does not account for any gain which can be associated to the precoding operation. The relative power of physical channels transmitted is defined in Table C.3.2-1. The SNR requirement applies for the UE categories and CA capabilities given for each test.

For enhanced performance requirements type A, the SINR is defined as

$$SINR = \frac{\sum_{j=1}^{N_{RX}} \hat{E}_s^{(j)}}{\sum_{j=1}^{N_{RX}} N_{oc}^{(j)'}}$$

where N_{RX} denotes the number of receiver antenna connectors and the superscript receiver antenna connector j . The above SINR definition assumes that the REs are not precoded. The SINR definition does not account for any gain which can be associated to the precoding operation. The relative power of physical channels transmitted is defined in Table C.3.2-1. The SINR requirement applies for the UE categories given for each test.

For the performance requirements specified in this clause, it is assumed that $N_{RX}=2$ unless otherwise stated.

Table 8.1.1-1: Void

8.1.1.1 Simultaneous unicast and MBMS operations

8.1.1.2 Dual-antenna receiver capability in idle mode

8.1.2 Applicability of requirements

8.1.2.1 Applicability of requirements for different channel bandwidths

In Clause 8 the test cases may be defined with different channel bandwidth to verify the same target FRC conditions with the same propagation conditions, correlation matrix and antenna configuration.

Test cases defined for 5MHz channel bandwidth that reference this clause are applicable to UEs that support only Band 31.

8.1.2.2 Definition of CA capability

The definition with respect to CA capabilities for 2CCs is given as in Table 8.1.2.2-1. The definition with respect to CA capabilities for 3CCs is given in Table 8.1.2.2-3.

Table 8.1.2.2-1: Definition of CA capability with 2DL CCs

CA Capability	CA Capability Description
CA2_C	Intra-band contiguous CA
CA2_A2	Inter-band CA (two bands)
CA2_N2	Intra-band non-contiguous CA (with two sub-blocks)
Note 1:	CA2_C corresponds to E-UTRA CA configurations and bandwidth combination sets defined in Table 5.6A.1-1 for 2 DL CCs. CA2_A2 corresponds to E-UTRA CA configurations and bandwidth combination sets defined in Table 5.6A.1-2 for 2 DL CCs. CA2_N2 corresponds to E-UTRA CA configurations and bandwidth combination sets defined in Table 5.6A.1-3 for 2 DL CCs.

The supported testable aggregated CA bandwidth combinations for 2CCs for each CA capability are listed in Table 8.1.2.2-2.

Table 8.1.2.2-2: Supported testable aggregated CA bandwidth combinations for different CA capability with 2DL CCs

CA Capability	Bandwidth combination for FDD CA	Bandwidth combination for TDD CA	Bandwidth combination for TDD-FDD CA
CA2_C	5+5MHz, 5+10MHz, 10+10MHz, 20+20MHz	20+20MHz, 15+20MHz	NA
CA2_A2	10+10MHz, 10+15MHz, 10+20MHz, 15+20MHz, 20+20MHz	20+20MHz	10(FDD)+20(TDD)MHz, 15(FDD)+20(TDD)MHz, 20(FDD)+20(TDD)MHz
CA2_N2	5+10MHz, 10+10MHz, 20+20MHz	20+20MHz	NA
Note 1:	This table is only for information and applicability and test rules of CA performance requirements are specified in 8.1.2.3 and 9.1.1.2.		

Table 8.1.2.2-3: Definition of CA capability with 3 DL CCs

CA Capability	CA Capability Description
CA3_C	Intra-band contiguous CA
CA3_A2	Inter-band CA (two bands)
CA3_A3	Inter-band CA (three bands)
CA3_N2	Intra-band non-contiguous CA (with two sub-blocks)
Note 1:	CA3_C corresponds to E-UTRA CA configurations and bandwidth combination sets defined in Table 5.6A.1-1 for 3 DL CCs. CA3_A2 corresponds to E-UTRA CA configurations and bandwidth combination sets defined in Table 5.6A.1-2 for 3 DL CCs. CA3_A3 corresponds to E-UTRA CA configurations and bandwidth combination sets defined in and Table 5.6A.1-2a for 3 DL CCs. CA3_N2 corresponds to E-UTRA CA configurations and bandwidth combination sets defined in Table 5.6A.1-3 for 3 DL CCs.

The supported testable largest aggregated CA bandwidth combinations for 3CCs for each CA capability are listed in Table 8.1.2.2-4.

Table 8.1.2.2-4: Supported largest aggregated CA bandwidth combinations for different CA capability with 3 CCs

CA capability	Bandwidth combination for FDD CA	Bandwidth combination for TDD CA	Bandwidth combination for TDD-FDD CA
CA3_C	NA	20+20+20MHz	NA
CA3_A2	5+10+20MHz, 10+10+20MHz, 10+20+20MHz, 20+20+20MHz	15+20+20MHz, 20+20+20MHz	15(FDD)+20(TDD)+20(TDD)MHz, 20(FDD)+20(TDD)+20(TDD)MHz
CA3_A3	10+10+20MHz, 10+15+15MHz, 10+15+20MHz, 10+20+20MHz, 15+15+20MHz, 15+20+20MHz, 20+20+20MHz	NA	NA
CA3_N2	NA	20+20+20MHz	NA
Note 1:	This table is only for information and applicability and test rules of CA performance requirements are specified in 8.1.2.3 and 9.1.1.2.		

For test cases with more than one component carrier, "Fraction of Maximum Throughput" in the performance requirement refers to the ratio of the sum of throughput values of all component carriers to the sum of the nominal maximum throughput values of all component carriers, unless otherwise stated.

8.1.2.2A Definition of dual connectivity capability

The definition with respect to dual connectivity capabilities for configurations with 2CCs is given as in Table 8.1.2.2A-1.

Table 8.1.2.2A-1: Definition of dual connectivity capability with 2DL CCs

Dual connectivity Capability	Dual connectivity capability Description
DC_A_2	Inter-band dual connectivity (two bands)
Note 1:	DC_A_2 corresponds to E-UTRA dual connectivity configurations and bandwidth combination sets defined for inter-band dual connectivity (two bands) as specified in 5.6C.

The supported testable dual connectivity bandwidth combinations for 2CCs for each dual connectivity capability are listed in Table 8.1.2.2A-2.

Table 8.1.2.2A-2: Supported testable dual connectivity bandwidth combinations for different dual connectivities capability with 2DL CCs

Dual connectivity capability	Bandwidth combination for FDD dual connectivity	Bandwidth combination for TDD dual connectivity
DC_A_2	10+10MHz, 10+20MHz, 15+15MHz, 15+20MHz, 20+20MHz	20+20MHz
Note 1: This table is only for information and applicability and test rules of dual connectivity performance requirements are specified in 8.1.2.3A		

8.1.2.3 Applicability and test rules for different CA configurations and bandwidth combination sets

The performance requirement for CA UE demodulation tests in Clause 8 are defined independent of CA configurations and bandwidth combination sets specified in Clause 5.6A.1. For UEs supporting different CA configurations and bandwidth combination sets, the applicability and test rules are defined for the tests for 2 DL CCs in Table 8.1.2.3-1 and 3DL CCs in Table 8.2.2.3-2. For simplicity, CA configuration below refers to combination of CA configuration and bandwidth combination set.

Table 8.1.2.3-1: Applicability and test rules for CA UE demodulation tests with 2 DL CCs

Tests	CA capability where the tests apply	CA configuration from the selected CA capability where the tests apply	CA Bandwidth combination to be tested in priority order
CA tests with 2CCs in Clause 8.2.1.1.1, 8.2.1.4.3	Any one of the supported CA capabilities	Any one of the supported FDD CA configurations	10+10 MHz, 20+20 MHz, 5+5 MHz, and 10MHz+5MHz.
CA tests with 2CCs in Clause 8.2.1.3.1	Each supported CA capability	Any one of the supported FDD CA configurations in each CA capability	10+10 MHz, 20+20 MHz, 5+5 MHz, and 10MHz+5MHz.
CA tests with 2CCs in Clause 8.2.1.3.1A, 8.7.1	Any one of the supported CA capabilities with largest aggregated CA bandwidth combination	Any one of the supported FDD CA configurations with largest aggregated CA bandwidth combination	Largest aggregated CA bandwidth combination
CA tests with 2CCs in Clause 8.2.1.7.1	CA_C	Supported FDD intra-band contiguous CA configurations covering the lowest and highest operating bands	Largest aggregated CA bandwidth combinations
CA tests with 2CCs in Clause 8.2.2.1.1, 8.2.2.4.3	Any one of the supported CA capabilities with largest aggregated CA bandwidth combination	Any one of the supported TDD CA configurations with largest aggregated CA bandwidth combination	Largest aggregated CA bandwidth combination
CA tests with 2CCs in Clause 8.2.2.3.1	Each supported CA capability	Any one of the supported TDD CA configurations in each CA capability with largest aggregated CA bandwidth combination	Largest aggregated CA bandwidth combination
CA tests with 2CCs in Clause 8.2.2.3.1A, 8.7.2	Any one of the supported CA capabilities with largest aggregated CA bandwidth	Any one of the supported TDD CA configurations with largest aggregated CA bandwidth combination	Largest aggregated CA bandwidth combination
CA tests with 2CCs in 8.2.2.7.1	CA_C	Supported TDD intra-band contiguous CA configurations covering the lowest and highest operating bands	Largest aggregated CA bandwidth combinations
CA tests with 2CCs in Clause 8.2.1.8.1	CA_N	CA_3A-3A defined in Table 5.6A.1-3	10+10 MHz
CA tests with 2CCs in Clause 8.2.2.8.1	CA2_C	CA_41C defined in Table 5.6A.1-1	20+20 MHz
Note 1:	The applicability and test rules are specified in this table, unless otherwise stated.		
Note 2:	Number of the supported bandwidth combinations to be tested from each selected CA configuration is 1.		
Note 3:	A single Uplink CC is configured for all tests		

Table 8.1.2.3-2: Applicability and test rules for CA UE demodulation tests with 3 DL CCs

Tests	CA capability where the tests apply	CA configuration from the selected CA capability where the tests apply	CA Bandwidth combination to be tested in priority order
CA tests with 3CCs in Clause 8.2.1.1.1, 8.2.1.4.3, 8.7.1	Any one of the supported CA capabilities with largest aggregated CA bandwidth combination	Any one of the supported FDD CA configurations with largest aggregated CA bandwidth combination	Largest aggregated CA bandwidth combination
CA tests with 3CCs in Clause 8.2.1.3.1	Each supported CA capability	Any one of the supported FDD CA configurations in each CA capability with largest aggregated CA bandwidth combination	Largest aggregated CA bandwidth combination
CA tests with 3CCs in Clause 8.2.2.1.1, 8.2.2.4.3, 8.7.2	Any one of the supported CA capabilities with largest aggregated CA bandwidth combination	Any one of the supported TDD CA configurations with largest aggregated CA bandwidth combination	Largest aggregated CA bandwidth combination
CA tests with 3CCs in Clause 8.2.2.3.1	Each supported CA capability	Any one of the supported TDD CA configurations in each CA capability with largest aggregated CA bandwidth combination	Largest aggregated CA bandwidth combination
CA tests with 3CCs in Clause 8.2.2.8.1	CA3_C	CA_41D defined in Table 5.6A.1-1	20+20+20 MHz
Note 1: The applicability and test rules are specified in this table, unless otherwise stated. Note 2: Number of the supported bandwidth combinations to be tested from each selected CA configuration is 1. Note 3: A single Uplink CC is configured for all tests			

8.1.2.3A Applicability and test rules for different dual connectivity configuration and bandwidth combination set

The performance requirement for dual connectivity UE demodulation tests in Clause 8 are defined independent of dual connectivity configurations and bandwidth combination sets specified in Clause 5.6C.1. For UEs supporting different dual connectivity configurations and bandwidth combination sets, the applicability and test rules are defined for the tests for the configurations with 2CCs in Table 8.1.2.3A-1. For simplicity, dual connectivity configuration below refers to combination of dual connectivity configuration and bandwidth set.

Both CA performance requirements and dual connectivity performance requirements are applied for dual connectivity capable UE.

Table 8.1.2.3A-1: Applicability and test rules for dual connectivity UE demodulation tests with 2DL CCs

Tests	Dual connectivity capability where the tests apply	Dual connectivity configuration from the selected CA capability where the tests apply	Dual connectivity Bandwidth combination to be tested in priority order
Dual connectivity test in Clause 8.2.1.4.3A, 8.7.6	Any one of the supported dual connectivity capabilities with largest aggregated dual connectivity bandwidth combination	Any one of the supported FDD dual connectivity configurations with the largest aggregated dual connectivity bandwidth combination	Largest dual connectivity aggregated bandwidth combination
Dual connectivity test in Clause 8.2.2.4.3A, 8.7.7	Any one of the supported dual connectivity capabilities with largest aggregated dual connectivity bandwidth combination	Any one of the supported TDD dual connectivity configurations with the largest aggregated dual connectivity bandwidth combination	Largest dual connectivity aggregated bandwidth combination

Note 1: The applicability and test rules are specified in this table, unless otherwise stated.
Note 2: Number of the supported bandwidth combinations to be tested from each selected DC or CA configuration is 1.

8.1.2.3B Applicability and test rules for different TDD-FDD CA configurations and bandwidth combination sets

The performance requirement for TDD-FDD CA UE demodulation tests in Clause 8 are defined independent of CA configurations and bandwidth combination sets specified in Clause 5.6A.1. For UEs supporting different CA configurations and bandwidth combination sets, the applicability and test rules are defined for the tests for 2 DL TDD-FDD CA in Table 8.1.2.3B-1 and in Table 8.1.2.3B-2 for 3 DL TDD-FDD CA. For simplicity, CA configuration below refers to combination of CA configuration and bandwidth combination set.

Table 8.1.2.3B-1: Applicability and test rules for CA UE demodulation tests for TDD-FDD CA with 2 DL CCs

Tests	CA capability where the tests apply	CA configuration from the selected CA capability where the tests apply	CA Bandwidth combination to be tested in priority order
CA tests with 2CCs in Clause 8.2.3.1.1, 8.2.3.2.1A, 8.2.3.3.1, 8.7.5.1	Any one of the supported CA capabilities with largest aggregated CA bandwidth combination	Any one of the supported TDD-FDD CA configurations with FDD PCell with largest aggregated CA bandwidth combination	Largest aggregated CA bandwidth combination
CA tests with 2CCs in Clause 8.2.3.2.1	Each supported CA capability	Any one of the supported TDD-FDD CA configurations with FDD PCell in each CA capability with largest aggregated CA bandwidth combination	Largest aggregated CA bandwidth combination
CA tests with 2CCs in Clause 8.2.3.1.2, 8.2.3.2.2A, 8.2.3.3.2, 8.7.5.2	Any one of the supported CA capabilities with largest aggregated CA bandwidth combination	Any one of the supported TDD-FDD CA configurations with TDD PCell with largest aggregated CA bandwidth combination	Largest aggregated CA bandwidth combination
CA tests with 2CCs in Clause 8.2.3.2.2	Each supported CA capability	Any one of the supported TDD-FDD CA configurations with TDD PCell in each CA capability with largest aggregated CA bandwidth combination	Largest aggregated CA bandwidth combination

Note 1: The applicability and test rules are specified in this table, unless otherwise stated.
Note 2: Number of the supported bandwidth combinations to be tested from each selected CA configuration is 1.
Note 3: A single Uplink CC is configured for all tests

Table 8.1.2.3B-2: Applicability and test rules for CA UE demodulation tests for TDD-FDD CA with 3 DL CCs

Tests	CA capability where the tests apply	CA configuration from the selected CA capability where the tests apply	CA Bandwidth combination to be tested in priority order
CA tests with 3CCs in Clause 8.2.3.1.1, 8.2.3.2.1A, 8.2.3.3.1, 8.7.5.1	Any one of the supported CA capabilities with largest aggregated CA bandwidth combination	Any one of the supported TDD-FDD CA configurations with FDD PCell with largest aggregated CA bandwidth combination	Largest aggregated CA bandwidth combination
CA tests with 3CCs in Clause 8.2.3.2.1	Each supported CA capability	Any one of the supported TDD-FDD CA configurations with FDD PCell in each CA capability with largest aggregated CA bandwidth combination	Largest aggregated CA bandwidth combination
CA tests with 3CCs in Clause 8.2.3.1.2, 8.2.3.2.2A, 8.2.3.3.2, 8.7.5.2	Any one of the supported CA capabilities with largest aggregated CA bandwidth combination	Any one of the supported TDD-FDD CA configurations with TDD PCell with largest aggregated CA bandwidth combination	Largest aggregated CA bandwidth combination
CA tests with 3CCs in Clause 8.2.3.2.2	Each supported CA capability	Any one of the supported TDD-FDD CA configurations with TDD PCell in each CA capability with largest aggregated CA bandwidth combination	Largest aggregated CA bandwidth combination
Note 1: The applicability and test rules are specified in this table, unless otherwise stated.			
Note 2: Number of the supported bandwidth combinations to be tested from each selected CA configuration is 1.			
Note 3: A single Uplink CC is configured for all tests			

8.1.2.4 Test coverage for different number of component carriers

For FDD tests specified in 8.2.1.1.1, 8.2.1.3.1, 8.2.1.4.3, and 8.7.1, if corresponding CA tests are tested, the test coverage can be considered fulfilled without executing single carrier tests.

For TDD tests specified in 8.2.2.1.1, 8.2.2.3.1, 8.2.2.4.3, and 8.7.2, if corresponding CA tests are tested, the test coverage can be considered fulfilled without executing single carrier tests.

For TDD FDD tests specified in 8.2.3.1, 8.2.3.2, 8.2.3.3, and 8.7.5, if corresponding TDD FDD CA tests are tested, the test coverage can be considered fulfilled without executing both FDD and TDD single carrier tests.

For FDD CA tests specified in 8.2.1.1.1, 8.2.1.4.3, and 8.7.1, among all supported CA capabilities, if corresponding CA tests with the largest number of CCs supported by the UE are tested, the test coverage can be considered fulfilled without executing the CA tests with less than the largest number of CCs supported by the UE.

For FDD CA tests specified in 8.2.1.3.1, for each supported CA capability, if corresponding CA tests with the largest number of CCs supported by the UE are tested, the test coverage can be considered fulfilled without executing the CA tests with less than the largest number of CCs supported by the UE.

For TDD CA tests specified in 8.2.2.1.1, 8.2.2.4.3, and 8.7.2, among all supported CA capabilities, if corresponding CA tests with the largest number of CCs supported by the UE are tested, the test coverage can be considered fulfilled without executing the CA tests with less than the largest number of CCs supported by the UE.

For TDD CA tests specified in 8.2.2.3.1, for each supported CA capability, if corresponding CA tests with the largest number of CCs supported by the UE are tested, the test coverage can be considered fulfilled without executing the CA tests with less than the largest number of CCs supported by the UE.

For TDD FDD CA tests specified in 8.2.3.1, 8.2.3.3, and 8.7.5, among all supported CA capabilities, if corresponding CA tests with the largest number of CCs supported by the UE are tested, the test coverage can be considered fulfilled without executing the TDD FDD CA tests with less than the largest number of CCs supported by the UE.

For TDD FDD CA tests specified in 8.2.3.2, for each supported CA capability, if corresponding CA tests with the largest number of CCs supported by the UE are tested, the test coverage can be considered fulfilled without executing the TDD FDD CA tests with less than the largest number of CCs supported by the UE.

For FDD CA power imbalance tests specified in 8.2.1.7.1, if they are are tested with FDD intra-band contiguous CA configurations with 2 DL CCs, the test coverage can be considered fulfilled with FDD intra-band contiguous CA configurations with 3 DL CCs supported by the UE.

For TDD CA power imbalance tests specified in 8.2.2.7.1, if they are are tested with TDD intra-band contiguous CA configurations with 2 DL CCs, the test coverage can be considered fulfilled with TDD intra-band contiguous CA configurations with 3 DL CCs supported by the UE.

8.1.2.5 Applicability of performance requirements for Type B receiver

For TM10 capable UE, if corresponding tests specified in 8.3.1.1F, 8.3.2.1G, 9.3.8.3 are tested, the test coverage can be considered fulfilled without executing the tests specified in 8.3.1.1C, 8.3.2.1D, 9.3.8.2. For a UE which does not have TM10 capability, the tests specified in sections 8.3.1.1C, 8.3.2.1D, 9.3.8.2 should be used.

8.1.3 UE category and UE DL category

UE category and UE DL category refer to *ue-Category* and *ue-CategoryDL* define in 4.1 and 4.1A from [12]. A UE that belongs to either a UE category or a UE DL category indicated in UE performance requirements in subclause 8, 9, 10 shall fulfil the corresponding requirements.

A UE indicating DL category 13 may indicate category 9 or 10 and shall thereby fulfil all requirements in subclause 8, 9, 10 that are indicated for either cat 9 or DL Cat 13 UEs. For SDR tests in section 8.7 both cat 9 and cat 13 test shall be used for this UE while for the other test only Cat 13 tests needs to be done.

8.2 Demodulation of PDSCH (Cell-Specific Reference Symbols)

8.2.1 FDD (Fixed Reference Channel)

The parameters specified in Table 8.2.1-1 are valid for all FDD tests unless otherwise stated.

Table 8.2.1-1: Common Test Parameters (FDD)

Parameter	Unit	Value
Inter-TTI Distance		1
Number of HARQ processes per component carrier	Processes	8
Maximum number of HARQ transmission		4
Redundancy version coding sequence		{0,1,2,3} for QPSK and 16QAM {0,0,1,2} for 64QAM and 256QAM
Number of OFDM symbols for PDCCH per component carrier	OFDM symbols	4 for 1.4 MHz bandwidth, 3 for 3 MHz and 5 MHz bandwidths, 2 for 10 MHz, 15 MHz and 20 MHz bandwidths unless otherwise stated
Cyclic Prefix		Normal
Cell_ID		0
Cross carrier scheduling		Not configured

8.2.1.1 Single-antenna port performance

The single-antenna performance in a given multi-path fading environments is determined by the SNR for which a certain relative information bit throughput of the reference measurement channels in Annex A.3.3 is achieved. The

purpose of these tests is to verify the single-antenna performance with different channel models and MCS. The QPSK and 64QAM cases are also used to verify the performance for all bandwidths specified in Table 5.6.1-1.

8.2.1.1.1 Minimum Requirement

For single carrier, the requirements are specified in Table 8.2.1.1.1-2, with the addition of the parameters in Table 8.2.1.1.1-1 and the downlink physical channel setup according to Annex C.3.2.

For CA with 2 DL CCs, the requirements are specified in Table 8.2.1.1.1-4, with the addition of the parameters in Table 8.2.1.1.1-3 and the downlink physical channel setup according to Annex C.3.2.

For CA with 3 DL CCs, the requirements are specified in Table 8.2.1.1.1-6, based on single carrier requirement specified in Table 8.2.1.1.1-5, with the addition of the parameters in Table 8.2.1.1.1-3 and the downlink physical channel setup according to Annex C.3.2.

The test coverage for different number of component carriers is defined in 8.1.2.4.

Table 8.2.1.1.1-1: Test Parameters

Parameter	Unit	Test 1- 5	Test 6- 8	Test 9- 15	Test 16- 18	Test 19
Downlink power allocation	ρ_A	dB	0	0	0	0
	ρ_B	dB	0 (Note 1)	0 (Note 1)	0 (Note 1)	0 (Note 1)
	σ	dB	0	0	0	0
N_{oc} at antenna port	dBm/15kHz	-98	-98	-98	-98	-98
Symbols for unused PRBs		OCNG (Note 2)	OCNG (Note 2)	OCNG (Note 2)	OCNG (Note 2)	OCNG (Note 2)
Modulation		QPSK	16QAM	64QAM	16QAM	QPSK
PDSCH transmission mode		1	1	1	1	1
Note 1: $P_B = 0$. Note 2: These physical resource blocks are assigned to an arbitrary number of virtual UEs with one PDSCH per virtual UE; the data transmitted over the OCNG PDSCHs shall be uncorrelated pseudo random data, which is QPSK modulated. Note 3: Void. Note 4: Void.						

Table 8.2.1.1.1-2: Minimum performance (FRC)

Test num.	Bandwidth	Reference channel	OCNG pattern	Propagation condition	Correlation matrix and antenna config.	Reference value		UE category
						Fraction of maximum throughput (%)	SNR (dB)	
1	10 MHz	R.2 FDD	OP.1 FDD	EVA5	1x2 Low	70	-1.0	≥1
2	10 MHz	R.2 FDD	OP.1 FDD	ETU70	1x2 Low	70	-0.4	≥1
3	10 MHz	R.2 FDD	OP.1 FDD	ETU300	1x2 Low	70	0.0	≥1
4	10 MHz	R.2 FDD	OP.1 FDD	HST	1x2	70	-2.4	≥1
5	1.4 MHz	R.4 FDD	OP.1 FDD	EVA5	1x2 Low	70	0.0	≥1
6	10 MHz	R.3 FDD	OP.1 FDD	EVA5	1x2 Low	70	6.7	≥2
	5 MHz	R.3-1 FDD	OP.1 FDD	EVA5	1x2 Low	70	6.7	1
	5 MHz (Note 4)	R.3-1 FDD	OP.1 FDD	EVA5	1x2 Low	70	6.7	≥2
7	10 MHz	R.3 FDD	OP.1 FDD	ETU70	1x2 Low	30	1.4	≥2
	5 MHz	R.3-1 FDD	OP.1 FDD	ETU70	1x2 Low	30	1.4	1
	5 MHz (Note 4)	R.3-1 FDD	OP.1 FDD	ETU70	1x2 Low	30	1.4	≥2
8	10 MHz	R.3 FDD	OP.1 FDD	ETU300	1x2 High	70	9.4	≥2
	5 MHz	R.3-1 FDD	OP.1 FDD	ETU300	1x2 High	70	9.4	1
	5 MHz (Note 4)	R.3-1 FDD	OP.1 FDD	ETU300	1x2 High	70	9.4	≥2
9	3 MHz	R.5 FDD	OP.1 FDD	EVA5	1x2 Low	70	17.6	≥1
10	5 MHz	R.6 FDD	OP.1 FDD	EVA5	1x2 Low	70	17.4	≥2
	5 MHz	R.6-1 FDD	OP.1 FDD	EVA5	1x2 Low	70	17.5	1
11	10 MHz	R.7 FDD	OP.1 FDD	EVA5	1x2 Low	70	17.7	≥2
	10 MHz	R.7-1 FDD	OP.1 FDD	EVA5	1x2 Low	70	16.7	1
12	10 MHz	R.7 FDD	OP.1 FDD	ETU70	1x2 Low	70	19.0	≥2
	10 MHz	R.7-1 FDD	OP.1 FDD	ETU70	1x2 Low	70	18.1	1
13	10 MHz	R.7 FDD	OP.1 FDD	EVA5	1x2 High	70	19.1	≥2
	10 MHz	R.7-1 FDD	OP.1 FDD	EVA5	1x2 High	70	17.8	1
14	15 MHz	R.8 FDD	OP.1 FDD	EVA5	1x2 Low	70	17.7	≥2
	15 MHz	R.8-1 FDD	OP.1 FDD	EVA5	1x2 Low	70	16.8	1
15	20 MHz	R.9 FDD	OP.1 FDD	EVA5	1x2 Low	70	17.6	≥3
	20 MHz	R.9-2 FDD	OP.1 FDD	EVA5	1x2 Low	70	17.3	2
	20 MHz	R.9-1 FDD	OP.1 FDD	EVA5	1x2 Low	70	16.7	1
16	3 MHz	R.0 FDD	OP.1 FDD	ETU70	1x2 Low	30	1.9	≥1
17	10 MHz	R.1 FDD	OP.1 FDD	ETU70	1x2 Low	30	1.9	≥1
18	20 MHz	R.1 FDD	OP.1 FDD	ETU70	1x2 Low	30	1.9	≥1
19	10 MHz	R.41 FDD	OP.1 FDD	EVA5	1x2 Low	70	-5.4	≥1
Note 1: Void. Note 2: Void. Note 3: Void. Note 4: Test case applicability is defined in 8.1.2.1.								

Table 8.2.1.1.1-3: Test Parameters for CA

Parameter		Unit	Value
Downlink power allocation	ρ_A	dB	0
	ρ_B	dB	0 (Note 1)
	σ	dB	0
N_{oc} at antenna port		dBm/15kHz	-98
Symbols for unused PRBs			OCNG (Note 2)
Modulation			QPSK
PDSCH transmission mode			1
Note 1: $P_B = 0$.			
Note 2: These physical resource blocks are assigned to an arbitrary number of virtual UEs with one PDSCH per virtual UE; the data transmitted over the OCNG PDSCHs shall be uncorrelated pseudo random data, which is QPSK modulated.			
Note 3: PUCCH format 1b with channel selection is used to feedback ACK/NACK for Tests in Table 8.2.1.1.1-4, PUCCH format 3 is used to feedback ACK/NACK for Tests in Table 8.2.1.1.1-6.			
Note 4: The same PDSCH transmission mode is applied to each component carrier.			

Table 8.2.1.1.1-4: Minimum performance (FRC) for CA with 2DL CCs

Test num.	Bandwidth	Reference channel	OCNG pattern	Propagation condition	Correlation matrix and antenna config.	Reference value		UE category
						Fraction of maximum throughput (%)	SNR (dB)	
1	2x10 MHz	R.2 FDD	OP.1 FDD (Note 1)	EVA5	1x2 Low	70	-1.1	≥ 3 (Note 2)
2	2x20 MHz	R.42 FDD	OP.1 FDD (Note 1)	EVA5	1x2 Low	70	-1.3	≥ 5
3	2x5 MHz	R.42-2 FDD	OP.1 FDD	EVA5	1x2 Low	70	-1.0	≥ 2
			OP.1 FDD			70	-1.0	
4	10MHz +5MHz	R.2 FDD for 10MHz CC	OP.1 FDD	EVA5	1x2 Low	70	-1.7	≥ 3
		R.42-2 FDD for 5MHz CC	OP.1 FDD			70	-1.0	
Note 1: The OCNG pattern applies for each CC.								
Note 2: 30usec timing difference between two CCs is applied in inter-band CA case.								
Note 3: The applicability of requirements for different CA configurations and bandwidth combination sets is defined in 8.1.2.3.								

Table 8.2.1.1.1-5: Single carrier performance for multiple CA configurations

Bandwidth	Reference channel	OCNG pattern	Propagation condition	Correlation matrix and antenna config.	Reference value	
					Fraction of maximum throughput (%)	SNR (dB)
1.4MHz	R.4 FDD	OP.1 FDD	EVA5	1x2 Low	70	-1.3
3MHz	R.42-1 FDD	OP.1 FDD	EVA5	1x2 Low	70	-1.1
5MHz	R.42-2 FDD	OP.1 FDD	EVA5	1x2 Low	70	-1.0
10MHz	R.2 FDD	OP.1 FDD	EVA5	1x2 Low	70	-1.7
15MHz	R.42-3 FDD	OP.1 FDD	EVA5	1x2 Low	70	-1.6
20MHz	R.42 FDD	OP.1 FDD	EVA5	1x2 Low	70	-1.7

Table 8.2.1.1.1-6: Minimum performance (FRC) based on single carrier performance for CA with 3DL CCs

Test num.	CA Band-width combination	Requirement	UE category
1	3x20MHz	As specified in Table 8.2.1.1.1-5 per CC	≥5
2	20MHz+20MHz+15MHz	As specified in Table 8.2.1.1.1-5 per CC	≥5
3	20MHz+20MHz+10MHz	As specified in Table 8.2.1.1.1-5 per CC	≥5
4	20MHz+15MHz+15MHz	As specified in Table 8.2.1.1.1-5 per CC	≥5
5	20MHz+15MHz+10MHz	As specified in Table 8.2.1.1.1-5 per CC	≥5
6	20MHz+10MHz+10MHz	As specified in Table 8.2.1.1.1-5 per CC	≥5
7	15MHz+15MHz+10MHz	As specified in Table 8.2.1.1.1-5 per CC	≥5
8	20MHz+10MHz+5MHz	As specified in Table 8.2.1.1.1-5 per CC	≥5
Note 1:	The applicability of requirements for different CA configurations and bandwidth combination sets is defined in 8.1.2.3		
Note 2:	30usec timing difference between PCell and any SCell which is not within the same band or sub-block as PCell, is applied in inter-band CA case, where PCell can be assigned on any CC.		

8.2.1.1.2 Void

8.2.1.1.3 Void

8.2.1.1.4 Minimum Requirement 1 PRB allocation in presence of MBSFN

The requirements are specified in Table 8.2.1.1.4-2, with the addition of the parameters in Table 8.2.1.1.4-1 and the downlink physical channel setup according to Annex C.3.2. The purpose of these tests is to verify the single-antenna performance with a single PRB allocated at the lower band edge in presence of MBSFN.

Table 8.2.1.1.4-1: Test Parameters for Testing 1 PRB allocation

Parameter	Unit	Test 1	
Downlink power allocation	ρ_A	dB	0
	ρ_B	dB	0 (Note 1)
	σ	dB	0
N_{oc} at antenna port	dBm/15kHz	-98	
Symbols for MBSFN portion of MBSFN subframes (Note 2)		OCNG (Note 3)	
PDSCH transmission mode		1	
Note 1: $P_B = 0$ Note 2: The MBSFN portion of an MBSFN subframe comprises the whole MBSFN subframe except the first two symbols in the first slot. Note 3: The MBSFN portion of the MBSFN subframes shall contain QPSK modulated data. Cell-specific reference signals are not inserted in the MBSFN portion of the MBSFN subframes, QPSK modulated MBSFN data is used instead.			

Table 8.2.1.1.4-2: Minimum performance 1PRB (FRC)

Test number	Bandwidth	Reference Channel	OCNG Pattern	Propagation Condition	Correlation Matrix and Antenna Configuration	Reference value		UE Category
						Fraction of Maximum Throughput (%)	SNR (dB)	
1	10 MHz	R.29 FDD	OP.3 FDD	ETU70	1x2 Low	30	2.0	≥1

8.2.1.2 Transmit diversity performance

8.2.1.2.1 Minimum Requirement 2 Tx Antenna Port

The requirements are specified in Table 8.2.1.2.1-2, with the addition of the parameters in Table 8.2.1.2.1-1 and the downlink physical channel setup according to Annex C.3.2. The purpose is to verify the performance of transmit diversity (SFBC) with 2 transmitter antennas.

Table 8.2.1.2.1-1: Test Parameters for Transmit diversity Performance (FRC)

Parameter		Unit	Test 1-2
Downlink power allocation	ρ_A	dB	-3
	ρ_B	dB	-3 (Note 1)
	σ	dB	0
N_{oc} at antenna port		dBm/15kHz	-98
PDSCH transmission mode			2
Note 1: $P_B = 1$.			

Table 8.2.1.2.1-2: Minimum performance Transmit Diversity (FRC)

Test number	Band-width	Reference Channel	OCNG Pattern	Propagation Condition	Correlation Matrix and Antenna Configuration	Reference value		UE Category
						Fraction of Maximum Throughput (%)	SNR (dB)	
1	10 MHz	R.11 FDD	OP.1 FDD	EVA5	2x2 Medium	70	6.8	≥ 2
	5 MHz	R.11-2 FDD	OP.1 FDD	EVA5	2x2 Medium	70	5.9	1
	5 MHz (Note 1)	R.11-2 FDD	OP.1 FDD	EVA5	2x2 Medium	70	5.9	≥ 2
2	10 MHz	R.10 FDD	OP.1 FDD	HST	2x2	70	-2.3	≥ 1
Note 1: Test case applicability is defined in 8.1.2.1.								

8.2.1.2.2 Minimum Requirement 4 Tx Antenna Port

The requirements are specified in Table 8.2.1.2.2-2, with the addition of the parameters in Table 8.2.1.2.2-1 and the downlink physical channel setup according Annex C.3.2. The purpose is to verify the performance of transmit diversity (SFBC-FSTD) with 4 transmitter antennas.

Table 8.2.1.2.2-1: Test Parameters for Transmit diversity Performance (FRC)

Parameter		Unit	Test 1-2
Downlink power allocation	ρ_A	dB	-3
	ρ_B	dB	-3 (Note 1)
	σ	dB	0
N_{oc} at antenna port		dBm/15kHz	-98
PDSCH transmission mode			2
Note 1: $P_B = 1$.			

Table 8.2.1.2.2-2: Minimum performance Transmit Diversity (FRC)

Test number	Band-width	Reference Channel	OCNG Pattern	Propagation Condition	Correlation Matrix and Antenna Configuration	Reference value		UE Category
						Fraction of Maximum Throughput (%)	SNR (dB)	
1	1.4 MHz	R.12 FDD	OP.1 FDD	EPA5	4x2 Medium	70	0.6	≥1
2	10 MHz	R.13 FDD	OP.1 FDD	ETU70	4x2 Low	70	-0.9	≥1

8.2.1.2.3 Minimum Requirement 2 Tx Antenna Port (demodulation subframe overlaps with aggressor cell ABS)

The requirements are specified in Table 8.2.1.2.3-2, with the addition of parameters in Table 8.2.1.2.3-1 and the downlink physical channel setup according to Annex C.3.2 and Annex C.3.3. The purpose is to verify the performance of transmit diversity (SFBC) with 2 transmit antennas if the PDSCH transmission in the serving cell takes place in subframes that overlap with ABS [9] of the aggressor cell. In Table 8.2.1.2.3-1, Cell 1 is the serving cell, and Cell 2 is the aggressor cell. The downlink physical channel setup for Cell 1 is according to Annex C.3.2 and for Cell 2 is according to Annex C.3.3, respectively.

Table 8.2.1.2.3-1: Test Parameters for Transmit diversity Performance (FRC)

Parameter		Unit	Cell 1	Cell 2
Downlink power allocation	ρ_A	dB	-3	-3
	ρ_B	dB	-3 (Note 1)	-3
	σ	dB	0	N/A
N_{oc} at antenna port	N_{oc1}	dBm/15kHz	-102 (Note 2)	N/A
	N_{oc2}	dBm/15kHz	-98 (Note 3)	N/A
	N_{oc3}	dBm/15kHz	-94.8 (Note 4)	N/A
\widehat{E}_s / N_{oc2}		dB	Reference Value in Table 8.2.1.2.3-2	6
BW _{Channel}		MHz	10	10
Subframe Configuration			Non-MBSFN	Non-MBSFN
Time Offset between Cells		μs	2.5 (synchronous cells)	
Cell Id			0	1
ABS pattern (Note 5)			N/A	11000100 11000000 11000000 11000000 11000000
RLM/RRM Measurement Subframe Pattern (Note 6)			10000000 10000000 10000000 10000000 10000000	N/A
CSI Subframe Sets (Note7)	$C_{CSI,0}$		11000100 11000000 11000000 11000000 11000000	N/A
	$C_{CSI,1}$		00111011 00111111 00111111 00111111 00111111	N/A
Number of control OFDM symbols			2	2
PDSCH transmission mode			2	N/A
Cyclic prefix			Normal	Normal
<p>Note 1: $P_B = 1$.</p> <p>Note 2: This noise is applied in OFDM symbols #1, #2, #3, #5, #6, #8, #9, #10, #12, #13 of a subframe overlapping with the aggressor ABS.</p> <p>Note 3: This noise is applied in OFDM symbols #0, #4, #7, #11 of a subframe overlapping with the aggressor ABS.</p> <p>Note 4: This noise is applied in all OFDM symbols of a subframe overlapping with aggressor non-ABS</p> <p>Note 5: ABS pattern as defined in [9].</p> <p>Note 6: Time-domain measurement resource restriction pattern for PCell measurements as defined in [7]</p> <p>Note 7: As configured according to the time-domain measurement resource restriction pattern for CSI measurements defined in [7].</p> <p>Note 8: Cell 1 is the serving cell. Cell 2 is the aggressor cell. The number of the CRS ports in Cell1 and Cell2 is the same.</p> <p>Note 9: SIB-1 will not be transmitted in Cell2 in this test.</p>				

Table 8.2.1.2.3-2: Minimum Performance Transmit Diversity (FRC)

Test Number	Reference Channel	OCNG Pattern		Propagation Conditions (Note 1)		Correlation Matrix and Antenna Configuration	Reference Value		UE Category
		Cell 1	Cell 2	Cell 1	Cell 2		Fraction of Maximum Throughput (%) Note 5	SNR (dB) (Note 2)	
1	R.11-4 FDD Note 4	OP.1 FDD	OP.1 FDD	EVA5	EVA 5	2x2 Medium	70	3.4	≥2
<p>Note 1: The propagation conditions for Cell 1 and Cell2 are statistically independent.</p> <p>Note 2: SNR corresponds to \hat{E}_s / N_{oc2} of cell 1.</p> <p>Note 3: The correlation matrix and antenna configuration apply for Cell 1 and Cell 2.</p> <p>Note 4: Cell 1 Reference channel is modified: PDSCH other than SIB1/paging and its associated PDCCH/PCFICH are transmitted in the serving cell subframe when the subframe is overlapped with the ABS subframe of aggressor cell and the subframe is available in the definition of the reference channel.</p> <p>Note 5: The maximum Throughput is calculated from the total Payload in 9 subframes, averaged over 40ms.</p>									

8.2.1.2.3A Minimum Requirement 2 Tx Antenna Ports (demodulation subframe overlaps with aggressor cell ABS and CRS assistance information are configured)

The requirements are specified in Table 8.2.1.2.3A-2, with the addition of parameters in Table 8.2.1.2.3A-1. The purpose is to verify the performance of transmit diversity (SFBC) with 2 transmit antennas if the PDSCH transmission in the serving cell takes place in subframes that overlap with ABS [9] of the aggressor cells with CRS assistance information. In Table 8.2.1.2.3A-1, Cell 1 is the serving cell, and Cell 2 and Cell 3 are the aggressor cells. The downlink physical channel setup for Cell 1 is according to Annex C.3.2 and for Cell 2 and Cell 3 is according to Annex C.3.3, respectively. The CRS assistance information [7] includes Cell 2 and Cell 3.

Table 8.2.1.2.3A-1: Test Parameters for Transmit diversity Performance (FRC)

Parameter		Unit	Cell 1	Cell 2	Cell 3
Downlink power allocation	ρ_A	dB	-3	-3	-3
	ρ_B	dB	-3 (Note 1)	-3 (Note 1)	-3 (Note 1)
	σ	dB	0	N/A	N/A
N_{oc} at antenna port	N_{oc1}	dBm/15kHz	-98 (Note 2)	N/A	N/A
	N_{oc2}	dBm/15kHz	-98 (Note 3)	N/A	N/A
	N_{oc3}	dBm/15kHz	-93 (Note 4)	N/A	N/A
\hat{E}_s / N_{oc2}		dB	Reference Value in Table 8.2.1.2.3 A-2	12	10
BW _{Channel}		MHz	10	10	10
Subframe Configuration			Non-MBSFN	Non-MBSFN	Non-MBSFN
Time Offset between Cells		μs	N/A	3	-1
Frequency shift between Cells		Hz	N/A	300	-100
Cell Id			0	126	1
ABS pattern (Note 5)			N/A	11000000 11000000 11000000 11000000 11000000	11000000 11000000 11000000 11000000 11000000
RLM/RRM Measurement Subframe Pattern (Note 6)			10000000 10000000 10000000 10000000 10000000	N/A	N/A
CSI Subframe Sets (Note 7)	$C_{CSI,0}$		11000000 11000000 11000000 11000000 11000000	N/A	N/A
	$C_{CSI,1}$		00111111 00111111 00111111 00111111 00111111	N/A	N/A
Number of control OFDM symbols			2	Note 8	Note 8
PDSCH transmission mode			2	Note 9	Note 9
Cyclic prefix			Normal	Normal	Normal
<p>Note 1: $P_B = 1$.</p> <p>Note 2: This noise is applied in OFDM symbols #1, #2, #3, #5, #6, #8, #9, #10, #12, #13 of a subframe overlapping with the aggressor ABS.</p> <p>Note 3: This noise is applied in OFDM symbols #0, #4, #7, #11 of a subframe overlapping with the aggressor ABS.</p> <p>Note 4: This noise is applied in all OFDM symbols of a subframe overlapping with aggressor non-ABS</p> <p>Note 5: ABS pattern as defined in [9].</p> <p>Note 6: Time-domain measurement resource restriction pattern for PCell measurements as defined in [7]</p> <p>Note 7: As configured according to the time-domain measurement resource restriction pattern for CSI measurements defined in [7].</p> <p>Note 8: The number of control OFDM symbols is not available for ABS and is 2 for the subframe indicated by "0" of ABS pattern.</p> <p>Note 9: Downlink physical channel setup in Cell 2 and Cell 3 in accordance with Annex C.3.3 applying OCN pattern as defined in Annex A.5.</p> <p>Note 10: The number of the CRS ports in Cell 1, Cell 2 and Cell 3 is the same.</p> <p>Note 11: SIB-1 will not be transmitted in Cell 2 and Cell 3 in this test.</p>					

Table 8.2.1.2.3A-2: Minimum Performance Transmit Diversity (FRC)

Test Number	Reference Channel	OCNG Pattern			Propagation Conditions (Note1)			Correlation Matrix and Antenna Configuration (Note 2)	Reference Value		UE Category
		Cell 1	Cell 2	Cell 3	Cell 1	Cell 2	Cell 3		Fraction of Maximum Throughput (%) Note 5	SNR (dB) (Note 3)	
1	R.11-4 FDD Note 4	OP.1 FDD	OP.1 FDD	OP.1 FDD	EVA5	EVA5	EVA5	2x2 Medium	70	3.4	≥2
Note 1:	The propagation conditions for Cell 1, Cell 2 and Cell 3 are statistically independent.										
Note 2:	The correlation matrix and antenna configuration apply for Cell 1, Cell 2 and Cell 3.										
Note 3:	SNR corresponds to \hat{E}_s / N_{oc2} of cell 1.										
Note 4:	Cell 1 Reference channel is modified: PDSCH other than SIB1/paging and its associated PDCCH/PCFICH are transmitted in the serving cell subframe when the subframe is overlapped with the ABS subframe of aggressor cell and the subframe is available in the definition of the reference channel.										
Note 5:	The maximum Throughput is calculated from the total Payload in 9 subframes, averaged over 40ms.										

8.2.1.2.4 Enhanced Performance Requirement Type A - 2 Tx Antenna Ports with TM3 interference model

The requirements are specified in Table 8.2.1.2.4-2, with the addition of parameters in Table 8.2.1.2.4-1 and the downlink physical channel setup according to Annex C.3.2. The purpose is to verify the performance of transmit diversity (SFBC) with 2 transmit antennas when the PDSCH transmission in the serving cell is interfered by PDSCH of two dominant interfering cells applying transmission mode 3 interference model defined in clause B.5.2. In Table 8.2.1.2.4-1, Cell 1 is the serving cell, and Cell 2, 3 are interfering cells. The downlink physical channel setup is according to Annex C.3.2 for each of Cell 1, Cell 2 and Cell 3, respectively.

Table 8.2.1.2.4-1: Test Parameters for Transmit diversity Performance (FRC) with TM3 interference model

Parameter		Unit	Cell 1	Cell 2	Cell 3
Downlink power allocation	ρ_A	dB	-3	-3	-3
	ρ_B	dB	-3 (Note 1)	-3	-3
	σ	dB	0	0	0
Cell-specific reference signals			Antenna ports 0,1	Antenna ports 0,1	Antenna ports 0,1
N_{oc} at antenna port		dBm/15kHz	-98	N/A	N/A
DIP (Note 2)		dB	N/A	-2.23	-8.06
$BW_{Channel}$		MHz	10	10	10
Cyclic Prefix			Normal	Normal	Normal
Cell Id			0	1	2
Number of control OFDM symbols			2	2	2
PDSCH transmission mode			2	N/A	N/A
Interference model			N/A	As specified in clause B.5.2	As specified in clause B.5.2
Probability of occurrence of transmission rank in interfering cells	Rank 1	%	N/A	80	80
	Rank 2	%	N/A	20	20
Reporting interval		ms	5	N/A	N/A
Reporting mode			PUCCH 1-0	N/A	N/A
Physical channel for CQI reporting			PUSCH(Note 5)	N/A	N/A
cqi-pmi-ConfigurationIndex			2	N/A	N/A
Note 1: $P_B = 1$ Note 2: The respective received power spectral density of each interfering cell relative to N_{oc} is defined by its associated DIP value as specified in clause B.5.1. Note 3: Cell 1 is the serving cell. Cell 2, 3 are the interfering cells. Note 4: Cell 2 transmission is delayed with respect to Cell 1 by 0.33 ms and Cell 3 transmission is delayed with respect to Cell 1 by 0.67 ms. Note 5: To avoid collisions between CQI reports and HARQ-ACK it is necessary to report both on PUSCH instead of PUCCH. PDCCH DCI format 0 shall be transmitted in downlink SF#1 and #6 to allow periodic CQI to multiplex with the HARQ-ACK on PUSCH in uplink subframe SF#5 and #0.					

Table 8.2.1.2.4-2: Enhanced Performance Requirement Type A, Transmit Diversity (FRC) with TM3 interference model

Test Number	Reference Channel	OCNG Pattern			Propagation Conditions			Correlation Matrix and Antenna Configuration (Note 3)	Reference Value		UE Category
		Cell 1	Cell 2	Cell 3	Cell 1	Cell 2	Cell 3		Fraction of Maximum Throughput (%)	SINR (dB) (Note 2)	
1	R.46 FDD	OP. 1 FD D	N/A	N/A	EV A70	EV A70	EV A70	2x2 Low	70	-1.1	≥ 1
Note 1: The propagation conditions for Cell 1, Cell 2 and Cell 3 are statistically independent. Note 2: SINR corresponds to \hat{E}_s / N_{oc} of Cell 1 as defined in clause 8.1.1. Note 3: Correlation matrix and antenna configuration parameters apply for each of Cell 1, Cell 2 and Cell 3.											

8.2.1.2.5 Enhanced Performance Requirement Type B - 2 Tx Antenna Ports with TM2 interference model

The requirements are specified in Table 8.2.1.2.5-2, with the addition of parameters in Table 8.2.1.2.5-1 and the downlink physical channel setup according to Annex C.3.2. The purpose is to verify the performance of transmit diversity (SFBC) with 2 transmit antennas when the PDSCH transmission in the serving cell is interfered by PDSCH of two interfering cells applying transmission mode 2 interference model defined in clause B.6.1. In Table 8.2.1.2.5-1, Cell 1 is the serving cell, and Cell 2, 3 are interfering cells. The downlink physical channel setup is according to Annex C.3.2 for each of Cell 1, Cell 2 and Cell 3, respectively.

Table 8.2.1.2.5-1: Test Parameters for Transmit Diversity Performance (FRC) with TM2 interference model

Parameter		Unit	Cell 1	Cell 2	Cell 3
Downlink power allocation	ρ_A	dB	-3	-3	-3
	ρ_B	dB	-3 (NOTE 1)	-3	-3
	σ	dB	0	0	0
Cell-specific reference signals			Antenna ports 0,1	Antenna ports 0,1	Antenna ports 0,1
N_{oc} at antenna port		dBm/15kHz	-98		
\hat{E}_s/N_{oc}		dB	N/A	13.91	3.34
BW _{Channel}		MHz	10	10	10
Cyclic Prefix			Normal	Normal	Normal
Cell Id			0	6	1
Number of control OFDM symbols			3	3	3
CFI indicated in PCFICH			3	3	3
PDSCH transmission mode			2	2	2
Interference model			N/A	As specified in clause B.6.1	As specified in clause B.6.1
MBSFN			Not configured	Not configured	Not configured
Time offset to cell 1		us	N/A	2	3
Frequency offset to cell 1		Hz	N/A	200	300
NeighCellsInfo-r12 (NOTE 3)	p-aList-r12		N/A	{dB-6, dB-3, dB0}	{dB-6, dB-3, dB0}
	transmissionModelList-r12		N/A	{2,3,4,8,9}	{2,3,4,8,9}
NOTE 1: $P_B = 1$					
NOTE 2: Cell 1 is the serving cell. Cell 2, 3 are the interfering cells.					
NOTE 3: NeighCellsInfo-r12 is described in subclause 6.3.2 of [7].					

Table 8.2.1.2.5-2: Minimum Performance for Enhanced Performance Requirement Type B, Transmit Diversity (FRC) with TM2 interference model

Test Number	Reference Channel	OCNG Pattern			Propagation Conditions			Correlation Matrix and Antenna Configuration (NOTE 3)	Reference Value		UE Category
		Cell 1	Cell 2	Cell 3	Cell 1	Cell 2	Cell 3		Fraction of Maximum Throughput (%)	SNR (dB) (NOTE 2)	
1	R.11-10 FDD	OP. 1 FDD	N/A	N/A	EP A5	EP A5	EP A5	2x2 Low	85	15.5	≥1
NOTE 1: The propagation conditions for Cell 1, Cell 2 and Cell 3 are statistically independent.											
NOTE 2: SNR corresponds to \hat{E}_s/N_{oc} of Cell 1 as defined in clause 8.1.1.											
NOTE 3: Correlation matrix and antenna configuration parameters apply for each of Cell 1, Cell 2 and Cell 3.											

8.2.1.2.6 Enhanced Performance Requirement Type B - 2 Tx Antenna Ports with TM9 interference model

The requirements are specified in Table 8.2.1.2.6-2, with the addition of parameters in Table 8.2.1.2.6-1 and the downlink physical channel setup according to Annex C.3.2. The purpose is to verify the performance of transmit diversity (SFBC) with 2 transmit antennas when the PDSCH transmission in the serving cell is interfered by PDSCH of two interfering cells applying transmission mode 9 interference model defined in clause B.6.4. In Table 8.2.1.2.6-1, Cell 1 is the serving cell, and Cell 2, 3 are interfering cells. The downlink physical channel setup is according to Annex C.3.2 for each of Cell 1, Cell 2 and Cell 3, respectively.

Table 8.2.1.2.6-1: Test Parameters for Transmit Diversity Performance (FRC) with TM9 interference model

Parameter		Unit	Cell 1	Cell 2	Cell 3
Downlink power allocation	ρ_A	dB	-3	0	0
	ρ_B	dB	-3 (NOTE 1)	0	0
	σ	dB	0	-3	-3
Cell-specific reference signals			Antenna ports 0,1	Antenna ports 0,1	Antenna ports 0,1
N_{oc} at antenna port		dBm/15kHz	-98		
\hat{E}_s/N_{oc}		dB	N/A	3.28	0.74
$BW_{Channel}$		MHz	10	10	10
Cyclic Prefix			Normal	Normal	Normal
Cell Id			0	1	6
Number of control OFDM symbols			3	3	3
CFI indicated in PCFICH			3	Random from set {1,2,3}	Random from set {1,2,3}
PDSCH transmission mode			2	9	9
Interference model			N/A	As specified in clause B.6.4	As specified in clause B.6.4
CSI reference signals			N/A	Antenna ports 15,16	Antenna ports 15,16
CSI-RS periodicity and subframe offset $T_{CSI-RS} / \Delta_{CSI-RS}$		Subframes	N/A	10 / 1	10 / 1
CSI reference signal configuration			N/A	6	7
Zero-power CSI-RS configuration $I_{CSI-RS} / ZeroPowerCSI-RS$ bitmap		Subframes / bitmap	N/A	6 / 0100000000000000	6 / 0010000000000000
Time offset to cell 1		us	N/A	5	-5
Frequency offset to cell 1		Hz	N/A	600	-600
MBSFN			Not configured	Not configured	Not configured
NeighCellsInfo-r12 (NOTE 4)	p-aList-r12		N/A	{dB-6, dB-3, dB0}	{dB-6, dB-3, dB0}
	transmissionModeList-r12		N/A	{2,3,4,8,9}	{2,3,4,8,9}
NOTE 1: $P_B = 1$					
NOTE 2: Cell 1 is the serving cell. Cell 2, 3 are the interfering cells.					
NOTE 3: CSI-RS configurations are according to [4] subclause 6.10.5.2.					
NOTE 4: NeighCellsInfo-r12 is described in subclause 6.3.2 of [7].					

Table 8.2.1.2.6-2: Minimum Performance for Enhanced Performance Requirement Type B, Transmit Diversity (FRC) with TM9 interference model

Test Number	Reference Channel	OCNG Pattern			Propagation Conditions			Correlation Matrix and Antenna Configuration (NOTE 3)	Reference Value		UE Category
		Cell 1	Cell 2	Cell 3	Cell 1	Cell 2	Cell 3		Fraction of Maximum Throughput (%)	SNR (dB) (NOTE 2)	
1	R.11-9 FDD	OP. 1 FDD	N/A	N/A	EP A5	EP A5	EP A5	2x2 Low	85	8.4	≥1

NOTE 1: The propagation conditions for Cell 1, Cell 2 and Cell 3 are statistically independent.

NOTE 2: SNR corresponds to \hat{E}_s/N_{oc} of Cell 1 as defined in clause 8.1.1.

NOTE 3: Correlation matrix and antenna configuration parameters apply for each of Cell 1, Cell 2 and Cell 3.

8.2.1.3 Open-loop spatial multiplexing performance

8.2.1.3.1 Minimum Requirement 2 Tx Antenna Port

For single carrier, the requirements are specified in Table 8.2.1.3.1-2, with the addition of the parameters in Table 8.2.1.3.1-1 and the downlink physical channel setup according to Annex C.3.2.

For CA with 2 DL CC, the requirements are specified in Table 8.2.1.3.1-4, with the addition of the parameters in Table 8.2.1.3.1-3 and the downlink physical channel setup according to Annex C.3.2. The purpose is to verify the performance of large delay CDD with 2 transmitter antennas.

For CA with 3 DL CCs, the requirements are specified in Table 8.2.1.3.1-6, based on single carrier requirement specified in Table 8.2.1.3.1-5, with the addition of the parameters in Table 8.2.1.3.1-3 and the downlink physical channel setup according to Annex C.3.2.

The test coverage for different number of component carriers is defined in 8.1.2.4.

Table 8.2.1.3.1-1: Test Parameters for Large Delay CDD (FRC)

Parameter	Unit	Test 1-4
Downlink power allocation	ρ_A	-3
	ρ_B	-3 (Note 1)
	σ	0
N_{oc} at antenna port	dBm/15kHz	-98
PDSCH transmission mode		3
Note 1: $P_B = 1$.		
Note 2: Void.		
Note 3: Void.		

Table 8.2.1.3.1-2: Minimum performance Large Delay CDD (FRC)

Test num	Bandwidth	Reference channel	OCNG pattern	Propagation condition	Correlation matrix and antenna config.	Reference value		UE category
						Fraction of maximum Throughput (%)	SNR (dB)	
1	10 MHz	R.11 FDD	OP.1 FDD	EVA70	2x2 Low	70	13.0	≥2
2 (Note 3)	5 MHz	R.11-2 FDD	OP.1 FDD	EVA70	2x2 Low	70	12.7	≥2
3	10 MHz	R.35 FDD	OP.1 FDD	EVA200	2x2 Low	70	20.2	≥2
4	10 MHz	R.35-4 FDD	OP.1 FDD	ETU600	2x2 Low	70	20.8	≥2

Note 1: Void.
Note 2: Test 1 may not be executed for UE-s for which Test 1 or 2 in Table 8.2.1.3.1-4 is applicable.
Note 3: Test case applicability is defined in 8.1.2.1.

Table 8.2.1.3.1-3: Test Parameters for Large Delay CDD (FRC) for CA

Parameter	Unit	Value	
Downlink power allocation	ρ_A	dB	-3
	ρ_B	dB	-3 (Note 1)
	σ	dB	0
N_{oc} at antenna port	dBm/15kHz	-98	
PDSCH transmission mode		3	

Note 1: $P_B = 1$.
Note 2: PUCCH format 1b with channel selection is used to feedback ACK/NACK for Tests in Table 8.2.1.3.1-4, PUCCH format 3 is used to feedback ACK/NACK for Tests in Table 8.2.1.3.1-6.
Note 3: The same PDSCH transmission mode is applied to each component carrier.

Table 8.2.1.3.1-4: Minimum performance Large Delay CDD (FRC) for CA with 2DL CCs

Test num	Bandwidth	Reference channel	OCNG pattern	Propagation condition	Correlation matrix and antenna config.	Reference value		UE category
						Fraction of maximum Throughput (%)	SNR (dB)	
1 (Note 2)	2x10 MHz	R.11 FDD	OP.1 FDD (Note 1)	EVA70	2x2 Low	70	13.7	≥3
2 (Note 2)	2x20 MHz	R.30 FDD	OP.1 FDD (Note 1)	EVA70	2x2 Low	70	13.2	≥5
3	2x5 MHz	R.11-2 FDD	OP.1 FDD	EVA70	2x2 Low	70	12.7	≥2
4	10MHz+5 MHz	R.11 FDD for 10MHz CC,	OP.1 FDD (Note 1)	EVA70	2x2 Low	70	13.0	≥3
		R.11-2 FDD for 5MHz CC	OP.1 FDD (Note 1)			70	12.7	

Note 1: The OCNG pattern applies for each CC.
Note 2: Void
Note 3: The applicability of requirements for different CA configurations and bandwidth combination sets is defined in 8.1.2.3.

Table 8.2.1.3.1-5: Single carrier performance for multiple CA configurations

Band-width	Reference channel	OCNG pattern	Propa-gation condition	Correlation matrix and antenna config.	Reference value	
					Fraction of maximum throughput (%)	SNR (dB)
1.4MHz	R.11-5 FDD	OP. 1 FDD	EVA70	2x2 Low	70	13.6
3MHz	R.11-6 FDD	OP. 1 FDD	EVA70	2x2 Low	70	12.3
5MHz	R.11-2 FDD	OP. 1 FDD	EVA70	2x2 Low	70	12.3
10 MHz	R.11 FDD	OP. 1 FDD	EVA70	2x2 Low	70	12.9
15MHz	R.11-7 FDD	OP. 1 FDD	EVA70	2x2 Low	70	12.8
20MHz	R.30 FDD	OP. 1 FDD	EVA70	2x2 Low	70	12.9

Table 8.2.1.3.1-6: Minimum performance (FRC) based on single carrier performance for CA with 3 DL CCs

Test num.	CA Band-width combination	Requirement	UE category
1	3x20MHz	As specified in Table 8.2.1.3.1-5 per CC	≥5
2	20MHz+20MHz+15MHz	As specified in Table 8.2.1.3.1-5 per CC	≥5
3	20MHz+20MHz+10MHz	As specified in Table 8.2.1.3.1-5 per CC	≥5
4	20MHz+15MHz+15MHz	As specified in Table 8.2.1.3.1-5 per CC	≥5
5	20MHz+15MHz+10MHz	As specified in Table 8.2.1.3.1-5 per CC	≥5
6	20MHz+10MHz+10MHz	As specified in Table 8.2.1.3.1-5 per CC	≥5
7	15MHz+15MHz+10MHz	As specified in Table 8.2.1.3.1-5 per CC	≥5
8	20MHz+10MHz+5MHz	As specified in Table 8.2.1.3.1-5 per CC	≥5
Note 1: The applicability of requirements for different CA configurations and bandwidth combination sets is defined in 8.1.2.3			

8.2.1.3.1A Soft buffer management test

For CA, the requirements are specified in Table 8.2.1.3.1A-2, with the addition of the parameters in Table 8.2.1.3.1A-1 and the downlink physical channel setup according to Annex C.3.2. The purpose is to verify the UE performance with proper instantaneous buffer implementation. The test points are applied to UE category and bandwidth combination with maximum aggregated bandwidth as specified in Table 8.2.1.3.1A-3.

Table 8.2.1.3.1A-1: Test Parameters for soft buffer management test (FRC) for CA

Parameter	Unit	Test 1-7
Downlink power allocation	ρ_A	dB
	ρ_B	dB
	σ	dB
N_{oc} at antenna port	dBm/15kHz	-98
PDSCH transmission mode		3
Note 1: $P_B = 1$.		
Note 2: For CA test cases, PUCCH format 1b with channel selection is used to feedback ACK/NACK.		
Note 3: For CA test cases, the same PDSCH transmission mode is applied to each component carrier.		

Table 8.2.1.3.1A-2: Minimum performance soft buffer management test (FRC) for CA

Test num	Bandwidth	Reference channel	OCNG pattern	Propagation condition	Correlation matrix and antenna config.	Reference value	
						Fraction of maximum Throughput (%)	SNR (dB)
1	2x20 MHz	R.30 FDD	OP.1 FDD (Note 1)	EVA70	2x2 Low	70	13.2
2	15MHz + 10MHz	R.35-2 FDD for 15MHz CC	OP.1 FDD (Note 1)	EVA5	2x2 Low	70	15.1
		R.35-3 FDD for 10MHz CC	OP.1 FDD (Note 1)			70	15.1
3	20MHz + 10MHz	R.30 FDD for 20MHz CC	OP.1 FDD (Note 1)	EVA70	2x2 Low	70	13.5
		R.11 FDD for 10MHz CC	OP.1 FDD (Note 1)			70	13.5
4	20MHz + 15MHz	R.30 FDD for 20MHz CC	OP.1 FDD (Note 1)	EVA70	2x2 Low	70	13.5
		R.30-1 FDD for 15MHz CC	OP.1 FDD (Note 1)			70	13.5
5	2x20 MHz	R.35-1 FDD	OP.1 FDD (Note 1)	EVA5	2x2 Low	70	15.8
6	20MHz + 10MHz	R.35-1 FDD for 20MHz CC	OP.1 FDD (Note 1)	EVA5	2x2 Low	70	15.9
		R.35-3 FDD for 10MHz CC	OP.1 FDD (Note 1)			70	15.9
7	20MHz + 15MHz	R.35-1 FDD for 20MHz CC	OP.1 FDD (Note 1)	EVA5	2x2 Low	70	15.9
		R.35-2 FDD for 15MHz CC	OP.1 FDD (Note 1)			70	15.9

Note 1: For CA test cases, the OCNG pattern applies for each CC.
Note 2: For Test 2, 3, 4, 6, 7 the Fraction of maximum Throughput applies to each CC.
Note 3: The applicability of requirements for different CA configurations and bandwidth combination sets is defined in 8.1.2.3.

Table 8.2.1.3.1A-3: Test points for soft buffer management tests for CA

UE category	Bandwidth combination with maximum aggregated bandwidth (Note 1)			
	2x20MHz	15MHz+10MHz	20MHz+10MHz	20MHz+15MHz
3	1	2	3	4
4	5	N/A	6	7

Note 1: Maximum over all supported CA configurations and bandwidth combination sets according to Table 5.6A.1-1 and Table 5.6A.1-2.

8.2.1.3.1B Enhanced Performance Requirement Type C –2Tx Antenna Ports

The requirements are specified in Table 8.2.1.3.1B-2, with the addition of the parameters in Table 8.2.1.3.1B-1 and the downlink physical channel setup according to Annex C.3.2. The purpose is to verify the performance of large delay CDD with 2 transmitter antennas.

Table 8.2.1.3.1B-1: Test Parameters for Large Delay CDD (FRC)

Parameter	Unit	Test 1	
Downlink power allocation	ρ_A	dB	-3
	ρ_B	dB	-3 (Note 1)
	σ	dB	0
N_{oc} at antenna port	dBm/15kHz	-98	
PDSCH transmission mode		3	
Note 1: $P_B = 1$.			

Table 8.2.1.3.1B-2: Enhanced Performance Requirement Type C for Large Delay CDD (FRC)

Test num	Bandwidth	Reference channel	OCNG pattern	Propagation condition	Correlation matrix and antenna config.	Reference value		UE category
						Fraction of maximum Throughput (%)	SNR (dB)	
1	10 MHz	R.11 FDD	OP.1 FDD	EVA70	2x2 Medium	70	17.8	≥2

8.2.1.3.1C Enhanced Performance Requirement Type C - 2 Tx Antenna Ports with TM1 interference

The requirements are specified in Table 8.2.1.3.1C-2, with the addition of parameters in Table 8.2.1.3.1C-1 and the downlink physical channel setup according to Annex C.3.2. The purpose is to verify the performance of open-loop spatial multiplexing performance with 2 transmit antennas when the PDSCH transmission in the serving cell is interfered by PDSCH of one dominant interfering cell with transmission mode 1. In Table 8.2.1.3.1C-1, Cell 1 is the serving cell, and Cell 2 is interfering cells. The downlink physical channel setup is according to Annex C.3.2 for each of Cell 1 and Cell 2 respectively.

Table 8.2.1.3.1C-1 Test parameters for Larger Delay CDD (FRC) with TM1 interference

Parameter	Unit	Cell 1	Cell 2
Bandwidth	MHz	10 MHz	
Downlink power allocation	ρ_A	-3	0
	ρ_B	-3 (Note 1)	0
	σ	0	0
Cell-specific reference signals		Antenna ports 0,1	Antenna port 0
Cyclic Prefix		Normal	Normal
Cell ID		0	1
Transmission mode		3	Note 2
N_{oc} at antenna port	dBm/15kHz	-98	N/A
\hat{E}_s/N_{oc} (Note 3)	dB	Reference Value in Table 8.2.1.3.1C-2	12.95
Correlation and antenna configuration		Medium (2x2)	Medium(1x2)
Number of OFDM symbols for PDCCH		2	N/A
Max number of HARQ transmissions		4	N/A
Redundancy version coding sequence		{0,1,2,3}	N/A
Note 1: $P_B = 1$ Note 2: Downlink physical channel setup in Cell 2 in accordance with Annex C.3.2 applying OCNG pattern OP.5 FDD as defined in Annex A.5.1.5. Note 3: Cell 1 is the serving cell. Cell 2 is the interfering cell. Note 4: All cells are time-synchronous. Note 5: SIB-1 will not be transmitted in Cell2 in this test.			

Table 8.2.1.3.1C-2 Enhanced Performance Requirement Type C, Larger Delay CDD (FRC) with TM1 interference

Test Number	Reference Channel	OCNG Pattern		Propagation Conditions (Note 1)		Reference Value		UE Category
		Cell 1	Cell 2	Cell 1	Cell 2	Fraction of Maximum Throughput (%)	SNR (dB) (Note 2)	
1	R.11-8 FDD	OP.1 FDD	OP.5 FDD	EVA70	EVA70	70	19.9	≥2
Note 1: The propagation conditions for Cell 1 and Cell 2 are statistically independent. Note 2: SNR corresponds to \hat{E}_s/N_{oc} of Cell 1.								

8.2.1.3.2 Minimum Requirement 4 Tx Antenna Port

The requirements are specified in Table 8.2.1.3.2-2, with the addition of the parameters in Table 8.2.1.3.2-1 and the downlink physical channel setup according to Annex C.3.2. The purpose is to verify the performance of large delay CDD with 4 transmitter antennas.

Table 8.2.1.3.2-1: Test Parameters for Large Delay CDD (FRC)

Parameter	Unit	Test 1	
Downlink power allocation	ρ_A	dB	-6
	ρ_B	dB	-6 (Note 1)
	σ	dB	3
N_{oc} at antenna port	dBm/15kHz	-98	
PDSCH transmission mode		3	
Note 1: $P_B = 1$			

Table 8.2.1.3.2-2: Minimum performance Large Delay CDD (FRC)

Test number	Bandwidth	Reference Channel	OCNG Pattern	Propagation Condition	Correlation Matrix and Antenna Configuration	Reference value		UE Category
						Fraction of Maximum Throughput (%)	SNR (dB)	
1	10 MHz	R.14 FDD	OP.1 FDD	EVA70	4x2 Low	70	14.3	≥2

8.2.1.3.3 Minimum Requirement 2 Tx Antenna Port (demodulation subframe overlaps with aggressor cell ABS)

The requirements for non-MBSFN ABS are specified in Table 8.2.1.3.3-2, with the addition of parameters in Table 8.2.1.3.3-1 and the downlink physical channel setup according to Annex C.3.2 and Annex C.3.3.

The requirements for MBSFN ABS are specified in Table 8.2.1.3.3-4, with the addition of parameters in Table 8.2.1.3.3-3 and the downlink physical channel setup according to Annex C.3.2 and Annex C.3.3.

The purpose is to verify the performance of large delay CDD with 2 transmitter antennas if the PDSCH transmission in the serving cell takes place in subframes that overlap with ABS [9] of the aggressor cell. In Tables 8.2.1.3.3-1 and 8.2.1.3.3-3, Cell 1 is the serving cell, and Cell 2 is the aggressor cell. The downlink physical channel setup for Cell 1 is according to Annex C.3.2 and for Cell 2 is according to Annex C.3.3, respectively.

Table 8.2.1.3.3-1: Test Parameters for Large Delay CDD (FRC) – Non-MBSFN ABS

Parameter		Unit	Cell 1	Cell 2
Downlink power allocation	ρ_A	dB	-3	-3
	ρ_B	dB	-3 (Note 1)	-3
	σ	dB	0	N/A
N_{oc} at antenna port	N_{oc1}	dBm/15kHz	-102 (Note 2)	N/A
	N_{oc2}	dBm/15kHz	-98 (Note 3)	N/A
	N_{oc3}	dBm/15kHz	-94.8 (Note 4)	N/A
\widehat{E}_s / N_{oc2}		dB	Reference Value in Table 8.2.1.3.3-2	6
BW _{Channel}		MHz	10	10
Subframe Configuration			Non-MBSFN	Non-MBSFN
Cell Id			0	1
Time Offset between Cells		μ s	2.5 (synchronous cells)	
ABS pattern (Note 5)			N/A	11000100, 11000000, 11000000, 11000000, 11000000
RLM/RRM Measurement Subframe Pattern(Note 6)			10000000 10000000 10000000 10000000 10000000	N/A
CSI Subframe Sets (Note 7)	$C_{CSI,0}$		11000100 11000000 11000000 11000000 11000000	N/A
	$C_{CSI,1}$		00111011 00111111 00111111 00111111 00111111	N/A
Number of control OFDM symbols			2	2
PDSCH transmission mode			3	N/A
Cyclic prefix			Normal	Normal
<p>Note 1: $P_B = 1$.</p> <p>Note 2: This noise is applied in OFDM symbols #1, #2, #3, #5, #6, #8, #9, #10, #12, #13 of a subframe overlapping with the aggressor ABS.</p> <p>Note 3: This noise is applied in OFDM symbols #0, #4, #7, #11 of a subframe overlapping with the aggressor ABS.</p> <p>Note 4: This noise is applied in all OFDM symbols of a subframe overlapping with aggressor non-ABS</p> <p>Note 5: ABS pattern as defined in [9].</p> <p>Note 6: Time-domain measurement resource restriction pattern for PCell measurements as defined in [7].</p> <p>Note 7: As configured according to the time-domain measurement resource restriction pattern for CSI measurements defined in [7].</p> <p>Note 8: Cell 1 is the serving cell. Cell 2 is the aggressor cell. The number of the CRS ports in Cell1 and Cell2 is the same.</p> <p>Note 9: SIB-1 will not be transmitted in Cell2 in this test.</p>				

Table 8.2.1.3.3-2: Minimum Performance Large Delay CDD (FRC) – Non-MBSFN ABS

Test Number	Reference Channel	OCNG Pattern		Propagation Conditions (Note 1)		Correlation Matrix and Antenna Configuration	Reference Value		UE Category
		Cell 1	Cell 2	Cell 1	Cell 2		Fraction of Maximum Throughput (%) Note 5	SNR (dB) (Note 2)	
1	R.11 FDD Note 4	OP.1 FDD	OP.1 FDD	EVA 5	EVA 5	2x2 Low	70	13.3	≥2
<p>Note 1: The propagation conditions for Cell 1 and Cell2 are statistically independent.</p> <p>Note 2: SNR corresponds to \hat{E}_s / N_{oc2} of cell 1.</p> <p>Note 3: The correlation matrix and antenna configuration apply for Cell 1 and Cell 2.</p> <p>Note 4: Cell 1 Reference channel is modified: PDSCH other than SIB1/paging and its associated PDCCH/PCFICH are transmitted in the serving cell subframe when the subframe is overlapped with the ABS subframe of aggressor cell and the subframe is available in the definition of the reference channel.</p> <p>Note 5: The maximum Throughput is calculated from the total Payload in 9 subframes, averaged over 40ms.</p>									

Table 8.2.1.3.3-3: Test Parameters for Large Delay CDD (FRC) – MBSFN ABS

Parameter		Unit	Cell 1	Cell 2
Downlink power allocation	ρ_A	dB	-3	-3
	ρ_B	dB	-3 (Note 1)	-3
	σ	dB	0	N/A
N_{oc} at antenna port	N_{oc1}	dBm/15kHz	-102 (Note 2)	N/A
	N_{oc2}	dBm/15kHz	-98 (Note 3)	N/A
	N_{oc3}	dBm/15kHz	-94.8 (Note 4)	N/A
\widehat{E}_s / N_{oc2}		dB	Reference Value in Table 8.2.1.3.3-4	6
BW _{Channel}		MHz	10	10
Subframe Configuration			Non-MBSFN	MBSFN
Cell Id			0	126
Time Offset between Cells		μ s	2.5 (synchronous cells)	
ABS pattern (Note 5)			N/A	0001000000 0100000010 0000001000 0000000000
RLM/RRM Measurement Subframe Pattern (Note 6)			0001000000 0100000010 0000001000 0000000000	N/A
CSI Subframe Sets (Note 7)	C _{CSI,0}		0001000000 0100000010 0000001000 0000000000	N/A
	C _{CSI,1}		1110111111 1011111101 1111110111 1111111111	N/A
MBSFN Subframe Allocation (Note 10)			N/A	001000 100001 000100 000000
Number of control OFDM symbols			2	2
PDSCH transmission mode			3	N/A
Cyclic prefix			Normal	Normal
<p>Note 1: $P_B = 1$.</p> <p>Note 2: This noise is applied in OFDM symbols #1, #2, #3, #4, #5, #6, #7, #8, #9, #10, #11, #12, #13 of a subframe overlapping with the aggressor ABS.</p> <p>Note 3: This noise is applied in OFDM symbol #0 of a subframe overlapping with the aggressor ABS.</p> <p>Note 4: This noise is applied in all OFDM symbols of a subframe overlapping with aggressor non-ABS.</p> <p>Note 5: ABS pattern as defined in [9]. The 4th, 12th, 19th and 27th subframes indicated by ABS pattern are MBSFN ABS subframes.</p> <p>Note 6: Time-domain measurement resource restriction pattern for PCell measurements as defined in [7].</p> <p>Note 7: As configured according to the time-domain measurement resource restriction pattern for CSI measurements defined in [7].</p> <p>Note 8: Cell 1 is the serving cell. Cell 2 is the aggressor cell. The number of the CRS ports in Cell1 and Cell2 is the same.</p> <p>Note 9: SIB-1 will not be transmitted in Cell2 in this test.</p> <p>Note 10: MBSFN Subframe Allocation as defined in [7], four frames with 24 bits is chosen for MBSFN subframe allocation.</p> <p>Note 11: The maximum number of uplink HARQ transmission is ≤ 2 so that each PHICH channel transmission is in a subframe protected by MBSFN ABS in this test.</p>				

Table 8.2.1.3.3-4: Minimum Performance Large Delay CDD (FRC) – MBSFN ABS

Test Number	Reference Channel	OCNG Pattern		Propagation Conditions (Note 2)		Correlation Matrix and Antenna Configuration	Reference Value		UE Category
		Cell 1	Cell 2	Cell 1	Cell 2		Fraction of Maximum Throughput (%) Note 5	SNR (dB) (Note 2)	
1	R.11 FDD Note 4	OP.1 FDD	OP.1 FDD	EVA 5	EVA 5	2x2 Low	70	12.0	≥2
<p>Note 1: The propagation conditions for Cell 1 and Cell2 are statistically independent.</p> <p>Note 2: SNR corresponds to \hat{E}_s/N_{oc2} of cell 1.</p> <p>Note 3: The correlation matrix and antenna configuration apply for Cell 1 and Cell 2.</p> <p>Note 4: Cell 1 Reference channel is modified: PDSCH other than SIB1/paging and its associated PDCCH/PCFICH are transmitted in the serving cell subframe when the subframe is overlapped with the ABS subframe of aggressor cell and the subframe is available in the definition of the reference channel.</p> <p>Note 5: The maximum Throughput is calculated from the total Payload in 4 subframes, averaged over 40ms.</p>									

8.2.1.3.4 Minimum Requirement 2 Tx Antenna Port (demodulation subframe overlaps with aggressor cell ABS and CRS assistance information are configured)

The requirements for non-MBSFN ABS are specified in Table 8.2.1.3.4-2, with the addition of parameters in Table 8.2.1.3.4-1. The purpose is to verify the performance of large delay CDD with 2 transmit antennas if the PDSCH transmission in the serving cell takes place in subframes that overlap with ABS [9] of the aggressor cells with CRS assistance information. In Table 8.2.1.3.4-1, Cell 1 is the serving cell, and Cell 2 and Cell 3 are the aggressor cells. The downlink physical channel setup for Cell 1 is according to Annex C.3.2 and for Cell 2 and Cell 3 is according to Annex C.3.3, respectively. The CRS assistance information [7] includes Cell 2 and Cell 3.

Table 8.2.1.3.4-1: Test Parameters for Large Delay CDD (FRC) – Non-MBSFN ABS

Parameter		Unit	Cell 1	Cell 2	Cell 3
Downlink power allocation	ρ_A	dB	-3	-3	-3
	ρ_B	dB	-3 (Note 1)	-3 (Note 1)	-3 (Note 1)
	σ	dB	0	N/A	N/A
N_{oc} at antenna port	N_{oc1}	dBm/15kHz	-98 (Note 2)	N/A	N/A
	N_{oc2}	dBm/15kHz	-98 (Note 3)	N/A	N/A
	N_{oc3}	dBm/15kHz	-93 (Note 4)	N/A	N/A
\hat{E}_s / N_{oc2}		dB	Reference Value in Table 8.2.1.3.4-2	Reference Value in Table 8.2.1.3.4-2	Reference Value in Table 8.2.1.3.4-2
$BW_{Channel}$		MHz	10	10	10
Subframe Configuration			Non-MBSFN	Non-MBSFN	Non-MBSFN
Time Offset between Cells		μ s	N/A	3	-1
Frequency shift between Cells		Hz	N/A	300	-100
Cell Id			0	1	126
ABS pattern (Note 5)			N/A	11000000 11000000 11000000 11000000 11000000	11000000 11000000 11000000 11000000 11000000
RLM/RRM Measurement Subframe Pattern (Note 6)			10000000 10000000 10000000 10000000 10000000	N/A	N/A
CSI Subframe Sets (Note7)	$C_{CSI,0}$		11000000 11000000 11000000 11000000 11000000	N/A	N/A
	$C_{CSI,1}$		00111111 00111111 00111111 00111111 00111111	N/A	N/A
Number of control OFDM symbols			2	Note 8	Note 8
PDSCH transmission mode			3	Note 9	Note 9
Cyclic prefix			Normal	Normal	Normal
<p>Note 1: $P_B = 1$.</p> <p>Note 2: This noise is applied in OFDM symbols #1, #2, #3, #5, #6, #8, #9, #10, #12, #13 of a subframe overlapping with the aggressor ABS.</p> <p>Note 3: This noise is applied in OFDM symbols #0, #4, #7, #11 of a subframe overlapping with the aggressor ABS.</p> <p>Note 4: This noise is applied in all OFDM symbols of a subframe overlapping with aggressor non-ABS</p> <p>Note 5: ABS pattern as defined in [9].</p> <p>Note 6: Time-domain measurement resource restriction pattern for PCell measurements as defined in [7]</p> <p>Note 7: As configured according to the time-domain measurement resource restriction pattern for CSI measurements defined in [7].</p> <p>Note 8: The number of control OFDM symbols is not available for ABS and is 2 for the subframe indicated by "0" of ABS pattern.</p> <p>Note 9: Downlink physical channel setup in Cell 2 and Cell 3 in accordance with Annex C.3.3 applying OCNG pattern as defined in Annex A.5.</p> <p>Note 10: The number of the CRS ports in Cell 1, Cell 2 and Cell 3 is the same.</p> <p>Note 11: SIB-1 will not be transmitted in Cell 2 and Cell 3 in this test.</p>					

Table 8.2.1.3.4-2: Minimum Performance Large Delay CDD (FRC) – Non-MBSFN ABS

Test Number	Reference Channel	\hat{E}_s/N_{oc2}		OCNG Pattern			Propagation Conditions (Note1)			Correlation Matrix and Antenna Configuration (Note 2)	Reference Value		UE Category
		Cell 2	Cell 3	Cell 1	Cell 2	Cell 3	Cell 1	Cell 2	Cell 3		Fraction of Maximum Throughput (%) Note 5	SNR (dB) (Note 3)	
1	R.11 FDD Note 4	9	7	OP.1 FDD	OP.1 FDD	OP.1 FDD	EVA5	EVA5	EVA5	2x2 Low	70	13.9	≥ 2
2	R.35 FDD Note 4	9	1	OP.1 FDD	OP.1 FDD	OP.1 FDD	EVA5	EVA5	EVA5	2x2 Low	70	22.6	≥ 2

Note 1: The propagation conditions for Cell 1, Cell 2 and Cell 3 are statistically independent.

Note 2: The correlation matrix and antenna configuration apply for Cell 1, Cell 2 and Cell 3.

Note 3: SNR corresponds to \hat{E}_s/N_{oc2} of cell 1.

Note 4: Cell 1 Reference channel is modified: PDSCH other than SIB1/paging and its associated PDCCH/PCFICH are transmitted in the serving cell subframe when the subframe is overlapped with the ABS subframe of aggressor cell and the subframe is available in the definition of the reference channel.

Note 5: The maximum Throughput is calculated from the total Payload in 9 subframes, averaged over 40ms.

8.2.1.4 Closed-loop spatial multiplexing performance

8.2.1.4.1 Minimum Requirement Single-Layer Spatial Multiplexing 2 Tx Antenna Port

The requirements are specified in Table 8.2.1.4.1-2, with the addition of the parameters in Table 8.2.1.4.1-1 and the downlink physical channel setup according to Annex C.3.2. The purpose of these tests is to verify the closed loop rank-one performance with wideband and frequency selective precoding.

Table 8.2.1.4.1-1: Test Parameters for Single-Layer Spatial Multiplexing (FRC)

Parameter	Unit	Test 1	Test 1A	Test 2
Downlink power allocation	ρ_A	dB	-3	-3
	ρ_B	dB	-3 (Note 1)	-3 (Note 1)
	σ	dB	0	0
N_{oc} at antenna port	dBm/15kHz	-98	-98	-98
Precoding granularity	PRB	6	4	50
PMI delay (Note 2)	ms	8	8	8
Reporting interval	ms	1	1	1
Reporting mode		PUSCH 1-2	PUSCH 1-2	PUSCH 3-1
CodeBookSubsetRestriction bitmap		001111	001111	001111
PDSCH transmission mode		4	4	4
Note 1: $P_B = 1$.				
Note 2: If the UE reports in an available uplink reporting instance at subframe SF#n based on PMI estimation at a downlink SF not later than SF#(n-4), this reported PMI cannot be applied at the eNB downlink before SF#(n+4).				

Table 8.2.1.4.1-2: Minimum performance Single-Layer Spatial Multiplexing (FRC)

Test number	Band-width	Reference Channel	OCNG Pattern	Propagation Condition	Correlation Matrix and Antenna Configuration	Reference value		UE Category
						Fraction of Maximum Throughput (%)	SNR (dB)	
1	10 MHz	R.10 FDD	OP.1 FDD	EVA5	2x2 Low	70	-2.5	≥1
1A (Note 1)	5 MHz	R.10-2 FDD	OP.1 FDD	EVA5	2x2 Low	70	-2.9	≥1
2	10 MHz	R.10 FDD	OP.1 FDD	EPA5	2x2 High	70	-2.3	≥1

Note 1: Test case applicability is defined in 8.1.2.1.

8.2.1.4.1A Minimum Requirement Single-Layer Spatial Multiplexing 4 Tx Antenna Port

The requirements are specified in Table 8.2.1.4.1A-2, with the addition of the parameters in Table 8.2.1.4.1A-1 and the downlink physical channel setup according to Annex C.3.2. The purpose of these tests is to verify the closed loop rank-one performance with wideband and frequency selective precoding.

Table 8.2.1.4.1A-1: Test Parameters for Single-Layer Spatial Multiplexing (FRC)

Parameter	Unit	Test 1	
Downlink power allocation	ρ_A	dB	-6
	ρ_B	dB	-6 (Note 1)
	σ	dB	3
N_{oc} at antenna port	dBm/15kHz	-98	
Precoding granularity	PRB	6	
PMI delay (Note 2)	ms	8	
Reporting interval	ms	1	
Reporting mode		PUSCH 1-2	
CodeBookSubsetRestriction on bitmap		0000000000000000 0000000000000000 0000000000000000 1111111111111111	
PDSCH transmission mode		4	
Note 1: $P_B = 1$.			
Note 2: If the UE reports in an available uplink reporting instance at subframe SF#n based on PMI estimation at a downlink SF not later than SF#(n-4), this reported PMI cannot be applied at the eNB downlink before SF#(n+4).			

Table 8.2.1.4.1A-2: Minimum performance Single-Layer Spatial Multiplexing (FRC)

Test number	Band-width	Reference Channel	OCNG Pattern	Propagation Condition	Correlation Matrix and Antenna Configuration	Reference value		UE Category
						Fraction of Maximum Throughput (%)	SNR (dB)	
1	10 MHz	R.13 FDD	OP.1 FDD	EVA5	4x2 Low	70	-3.2	≥1

8.2.1.4.1B Enhanced Performance Requirement Type A - Single-Layer Spatial Multiplexing 2 Tx Antenna Port with TM4 interference model

The requirements are specified in Table 8.2.1.4.1B-2, with the addition of the parameters in Table 8.2.1.4.1B-1 and the downlink physical channel setup according to Annex C.3.2. The purpose of these tests is to verify the closed loop rank-one performance with wideband precoding with two transmit antennas when the PDSCH transmission in the serving cell is interfered by PDSCH of two dominant interfering cells applying transmission mode 4 interference model defined

in clause B.5.3. In Table 8.2.1.4.1B-1, Cell 1 is the serving cell, and Cell 2, 3 are interfering cells. The downlink physical channel setup is according to Annex C.3.2 for each of Cell 1, Cell 2 and Cell 3, respectively.

Table 8.2.1.4.1B-1: Test Parameters for Single-Layer Spatial Multiplexing (FRC) with TM4 interference model

Parameter		Unit	Cell 1	Cell 2	Cell 3
Downlink power allocation	ρ_A	dB	-3	-3	-3
	ρ_B	dB	-3 (Note 1)	-3	-3
	σ	dB	0	0	0
Cell-specific reference signals			Antenna ports 0,1	Antenna ports 0,1	Antenna ports 0,1
N_{oc} at antenna port		dBm/15kHz	-98	N/A	N/A
DIP (Note 2)		dB	N/A	-1.73	-8.66
$BW_{Channel}$		MHz	10	10	10
Cyclic Prefix			Normal	Normal	Normal
Cell Id			0	1	2
Number of control OFDM symbols			2	2	2
PDSCH transmission mode			6	N/A	N/A
Interference model			N/A	As specified in clause B.5.3	As specified in clause B.5.3
Probability of occurrence of transmission rank in interfering cells	Rank 1	%	N/A	80	80
	Rank 2	%	N/A	20	20
Precoding granularity		PRB	50	6	6
PMI delay (Note 4)		ms	8	N/A	N/A
Reporting interval		ms	5	N/A	N/A
Reporting mode			PUCCH 1-1	N/A	N/A
CodeBookSubsetRestriction bitmap			1111	N/A	N/A
Physical channel for CQI reporting			PUSCH(Note 6)	N/A	N/A
cqi-pmi-ConfigurationIndex			2	N/A	N/A
<p>Note 1: $P_B = 1$</p> <p>Note 2: The respective received power spectral density of each interfering cell relative to N_{oc} is defined by its associated DIP value as specified in clause B.5.1.</p> <p>Note 3: Cell 1 is the serving cell. Cell 2, 3 are the interfering cells.</p> <p>Note 4: If the UE reports in an available uplink reporting instance at subframe SF#n based on PMI estimation at a downlink SF not later than SF#(n-4), this reported PMI cannot be applied at the eNB downlink before SF#(n+4).</p> <p>Note 5: All cells are time-synchronous.</p> <p>Note 6: To avoid collisions between CQI reports and HARQ-ACK it is necessary to report both on PUSCH instead of PUCCH. PDCCH DCI format 0 shall be transmitted in downlink SF#1 and #6 to allow periodic CQI to multiplex with the HARQ-ACK on PUSCH in uplink subframe SF#5 and #0.</p>					

Table 8.2.1.4.1B-2: Enhanced Performance Requirement Type A, Single-Layer Spatial Multiplexing (FRC) with TM4 interference model

Test Number	Reference Channel	OCNG Pattern			Propagation Conditions			Correlation Matrix and Antenna Configuration (Note 3)	Reference Value		UE Category
		Cell 1	Cell 2	Cell 3	Cell 1	Cell 2	Cell 3		Fraction of Maximum Throughput (%)	SINR (dB) (Note 2)	
1	R.47 FDD	OP. 1 FDD	N/A	N/A	EV A5	EV A5	EV A5	2x2 Low	70	0.8	≥1

Note 1: The propagation conditions for Cell 1, Cell 2 and Cell 3 are statistically independent.

Note 2: SINR corresponds to \hat{E}_s / N_{oc} of Cell 1 as defined in clause 8.1.1.

Note 3: Correlation matrix and antenna configuration parameters apply for each of Cell 1, Cell 2 and Cell 3.

8.2.1.4.1C Minimum Requirement Single-Layer Spatial Multiplexing 2 Tx Antenna Ports (demodulation subframe overlaps with aggressor cell ABS and CRS assistance information are configured)

The requirements are specified in Table 8.2.1.4.1C-2, with the addition of parameters in Table 8.2.1.4.1C-1. The purpose is to verify the closed loop rank-one performance with wideband precoding if the PDSCH transmission in the serving cell takes place in subframes that overlap with ABS [9] of the aggressor cell with CRS assistance information. In Table 8.2.1.4.1C-1, Cell 1 is the serving cell, and Cell 2 and Cell 3 are the aggressor cells. The downlink physical channel setup for Cell 1 is according to Annex C.3.2 and for Cell 2 and Cell 3 is according to Annex C.3.3, respectively. The CRS assistance information [7] includes Cell 2 and Cell 3.

Table 8.2.1.4.1C-1: Test Parameters for Single-Layer Spatial Multiplexing (FRC) – Non-MBSFN ABS

Parameter		Unit	Cell 1	Cell 2	Cell 3
Downlink power allocation	ρ_A	dB	-3	-3	-3
	ρ_B	dB	-3 (Note 1)	-3 (Note 1)	-3 (Note 1)
	σ	dB	0	N/A	N/A
N_{oc} at antenna port	N_{oc1}	dBm/15kHz	-98 (Note 2)	N/A	N/A
	N_{oc2}	dBm/15kHz	-98 (Note 3)	N/A	N/A
	N_{oc3}	dBm/15kHz	-93 (Note 4)	N/A	N/A
\hat{E}_s / N_{oc2}		dB	Reference Value in Table 8.2.1.4.1C-2	12	10
BW _{Channel}		MHz	10	10	10
Subframe Configuration			Non-MBSFN	Non-MBSFN	Non-MBSFN
Time Offset between Cells		μs	N/A	3	-1
Frequency shift between Cells		Hz	N/A	300	-100
Cell Id			0	126	1
ABS pattern (Note 5)			N/A	11000000 11000000 11000000 11000000 11000000	11000000 11000000 11000000 11000000 11000000
RLM/RRM Measurement Subframe Pattern (Note 6)			10000000 10000000 10000000 10000000 10000000	N/A	N/A
CSI Subframe Sets (Note7)	$C_{CSI,0}$		11000000 11000000 11000000 11000000 11000000	N/A	N/A
	$C_{CSI,1}$		00111111 00111111 00111111 00111111 00111111	N/A	N/A
Number of control OFDM symbols			2	Note 8	Note 8
PDSCH transmission mode			6	Note 9	Note 9
Precoding granularity		PRB	50	N/A	N/A
PMI delay (Note 10)		ms	8	N/A	N/A
Reporting interval		ms	1	N/A	N/A
Reporting mode			PUSCH 3-1	N/A	N/A
CodeBookSubsetRestriction bitmap			1111	N/A	N/A
Cyclic prefix			Normal	Normal	Normal

Note 1:	$P_B = 1$.
Note 2:	This noise is applied in OFDM symbols #1, #2, #3, #5, #6, #8, #9, #10, #12, #13 of a subframe overlapping with the aggressor ABS.
Note 3:	This noise is applied in OFDM symbols #0, #4, #7, #11 of a subframe overlapping with the aggressor ABS.
Note 4:	This noise is applied in all OFDM symbols of a subframe overlapping with aggressor non-ABS
Note 5:	ABS pattern as defined in [9].
Note 6:	Time-domain measurement resource restriction pattern for PCell measurements as defined in [7]
Note 7:	As configured according to the time-domain measurement resource restriction pattern for CSI measurements defined in [7].
Note 8:	The number of control OFDM symbols is not available for ABS and is 2 for the subframe indicated by "0" of ABS pattern.
Note 9:	Downlink physical channel setup in Cell 2 and Cell 3 in accordance with Annex C.3.3 applying OCNB pattern as defined in Annex A.5.
Note 10:	If the UE reports in an available uplink reporting instance at subframe SF#n based on PMI estimation at a downlink SF not later than SF#(n-4), this reported PMI cannot be applied at the eNB downlink before SF#(n+4).
Note 11:	The number of the CRS ports in Cell 1, Cell 2 and Cell 3 is the same.
Note 12:	SIB-1 will not be transmitted in Cell 2 and Cell 3 in this test.

Table 8.2.1.4.1C-2: Minimum Performance Single-Layer Spatial Multiplexing (FRC)– Non-MBSFN ABS

Test Number	Reference Channel	OCNB Pattern			Propagation Conditions (Note 1)			Correlation Matrix and Antenna Configuration (Note 2)	Reference Value		UE Category
		Cell 1	Cell 2	Cell 3	Cell 1	Cell 2	Cell 3		Fraction of Maximum Throughput (%) Note 5	SNR (dB) (Note 3)	
1	R.11 FDD Note 4	OP.1 FDD	OP.1 FDD	OP.1 FDD	EPA5	EPA5	EPA5	2x2 High	70	6.1	≥2
Note 1:	The propagation conditions for Cell 1, Cell 2 and Cell 3 are statistically independent.										
Note 2:	The correlation matrix and antenna configuration apply for Cell 1, Cell 2 and Cell 3.										
Note 3:	SNR corresponds to \hat{E}_s / N_{oc2} of cell 1.										
Note 4:	Cell 1 Reference channel is modified: PDSCH other than SIB1/paging and its associated PDCCH/PCFICH are transmitted in the serving cell subframe when the subframe is overlapped with the ABS subframe of aggressor cell and the subframe is available in the definition of the reference channel.										
Note 5:	The maximum Throughput is calculated from the total Payload in 9 subframes, averaged over 40ms.										

8.2.1.4.1D Enhanced Performance Requirement Type B - Single-layer Spatial Multiplexing 2 Tx Antenna Port with TM4 interference model

The requirements are specified in Table 8.2.1.4.1D-2, with the addition of the parameters in Table 8.2.1.4.1D-1 and the downlink physical channel setup according to Annex C.3.2. The purpose of these tests is to verify the closed loop rank-one performance with wideband precoding with two transmit antennas when the PDSCH transmission in the serving cell is interfered by PDSCH of two interfering cells applying transmission mode 4 interference model defined in clause B.6.3. In Table 8.2.1.4.1D-1, Cell 1 is the serving cell, and Cell 2, 3 are interfering cells. The downlink physical channel setup is according to Annex C.3.2 for each of Cell 1, Cell 2 and Cell 3, respectively.

Table 8.2.1.4.1D-1: Test Parameters for Single-layer Spatial Multiplexing (FRC) with TM4 interference model

Parameter		Unit	Cell 1	Cell 2	Cell 3		
Downlink power allocation	ρ_A	dB	-3	-3	-3		
	ρ_B	dB	-3 (NOTE 1)	-3	-3		
	σ	dB	0	0	0		
Cell-specific reference signals			Antenna ports 0,1	Antenna ports 0,1	Antenna ports 0,1		
N_{oc} at antenna port		dBm/15 kHz	-98				
Test number (NOTE 4)				Test 1	Test 2	Test 1	Test 2
\hat{E}_s/N_{oc}		dB	N/A	13.91	3.28	3.34	0.74
Cell Id				6	1	1	6
CFI indicated in PCFICH				3	Random from set {1,2,3}	3	Random from set {1,2,3}
BW _{Channel}		MHz	10	10	10		
Cyclic Prefix			Normal	Normal	Normal		
Number of control OFDM symbols			3	3	3		
PDSCH transmission mode			4	4	4		
Interference model			N/A	As specified in clause B.6.3	As specified in clause B.6.3		
Precoding			Random wideband precoding per TTI	As specified in clause B.6.3	As specified in clause B.6.3		
Time offset to cell 1		us	N/A	2	3		
Frequency offset to cell 1		Hz	N/A	200	300		
MBSFN			Not configured	Not configured	Not configured		
NeighCellsInfo-r12 (NOTE 3)	p-aList-r12		N/A	{dB-6, dB-3, dB0}	{dB-6, dB-3, dB0}		
	transmissionModeList-r12		N/A	{2,3,4,8,9}	{2,3,4,8,9}		
NOTE 1: $P_B = 1$							
NOTE 2: Cell 1 is the serving cell. Cell 2, 3 are the interfering cells.							
NOTE 3: NeighCellsInfo-r12 is described in subclause 6.3.2 of [7].							
NOTE 4: Test 1 and Test 2 are defined in Table 8.2.1.4.1D-2.							

Table 8.2.1.4.1D-2: Minimum Performance for Enhanced Performance Requirement Type B, Single-layer Spatial Multiplexing (FRC) with TM4 interference model

Test Num	Reference Channel	OCNG Pattern			Propagation Conditions			Correlation Matrix and Antenna Configuration (NOTE 3)	Reference Value		UE Category
		Cell 1	Cell 2	Cell 3	Cell 1	Cell 2	Cell 3		Fraction of Maximum Throughput (%)	SNR (dB) (NOTE 2)	
1	R.11-10 FDD	OP.1 FDD	N/A	N/A	EVA 5	EVA 5	EVA 5	2x2 Low	85	17.0	≥1
2	R.11-9 FDD	OP.1 FDD	N/A	N/A	EPA 5	EPA 5	EPA 5	2x2 Low	85	10.1	≥1
NOTE 1: The propagation conditions for Cell 1, Cell 2 and Cell 3 are statistically independent.											
NOTE 2: SNR corresponds to \hat{E}_s/N_{oc} of Cell 1 as defined in clause 8.1.1.											
NOTE 3: Correlation matrix and antenna configuration parameters apply for each of Cell 1, Cell 2 and Cell 3.											

8.2.1.4.2 Minimum Requirement Multi-Layer Spatial Multiplexing 2 Tx Antenna Port

The requirements are specified in Table 8.2.1.4.2-2, with the addition of the parameters in Table 8.2.1.4.2-1 and the downlink physical channel setup according to Annex C.3.2. The purpose of these tests is to verify the closed loop rank-two performance with wideband and frequency selective precoding.

Table 8.2.1.4.2-1: Test Parameters for Multi-Layer Spatial Multiplexing (FRC)

Parameter	Unit	Test 1-2	Test 2A	Test 3	
Downlink power allocation	ρ_A	dB	-3	-3	-3
	ρ_B	dB	-3 (Note 1)	-3 (Note 1)	-3 (Note 1)
	σ	dB	0	0	0
N_{oc} at antenna port	dBm/15kHz	-98	-98	-98	
Precoding granularity	PRB	50	25	6	
PMI delay (Note 2)	ms	8	8	8	
Reporting interval	ms	1	1	1	
Reporting mode		PUSCH 3-1	PUSCH 3-1	PUSCH 1-2	
CodeBookSubsetRestriction bitmap		110000	110000	110000	
PDSCH transmission mode		4	4	4	
Number of OFDM symbols for PDCCH per component carrier	OFDM symbol	2	3	1	
Note 1: $P_B = 1$.					
Note 2: If the UE reports in an available uplink reporting instance at subframe SF#n based on PMI estimation at a downlink SF not later than SF#(n-4), this reported PMI cannot be applied at the eNB downlink before SF#(n+4).					

Table 8.2.1.4.2-2: Minimum performance Multi-Layer Spatial Multiplexing (FRC)

Test number	Bandwidth	Reference Channel	OCNG Pattern	Propagation Condition	Correlation Matrix and Antenna Configuration	Reference value		UE Category	UE DL category
						Fraction of Maximum Throughput (%)	SNR (dB)		
1	10 MHz	R.35 FDD	OP.1 FDD	EPA5	2x2 Low	70	18.9	≥ 2	≥ 6
2	10 MHz	R.11 FDD	OP.1 FDD	ETU70	2x2 Low	70	14.3	≥ 2	≥ 6
2A (Note 1)	5 MHz	R.11-2 FDD	OP.1 FDD	ETU70	2x2 Low	70	14.0	≥ 2	≥ 6
3	10MHz 256QAM	R. 65 FDD	OP.1 FDD	EVA5	2x2 Low	70	25.3	11-12	≥ 11
Note 1: Test case applicability is defined in 8.1.2.1.									

8.2.1.4.2A Enhanced Performance Requirement Type C – Multi-layer Spatial Multiplexing 2Tx Antenna Ports

The requirements are specified in Table 8.2.1.4.2A-2, with the addition of the parameters in Table 8.2.1.4.2A-1 and the downlink physical channel setup according to Annex C.3.2. The purpose of these tests is to verify the closed loop rank-two performance with wideband precoding.

Table 8.2.1.4.2A-1: Test Parameters for Multi-Layer Spatial Multiplexing (FRC)

Parameter	Unit	Test 1	
Downlink power allocation	ρ_A	dB	-3
	ρ_B	dB	-3 (Note 1)
	σ	dB	0
N_{oc} at antenna port	dBm/15kHz	-98	
Precoding granularity	PRB	50	
PMI delay (Note 2)	ms	8	
Reporting interval	ms	1	
Reporting mode		PUSCH 3-1	
CodeBookSubsetRestriction bitmap		110000	
PDSCH transmission mode		4	
Note 1: $P_B = 1$.			
Note 2: If the UE reports in an available uplink reporting instance at subframe SF#n based on PMI estimation at a downlink SF not later than SF#(n-4), this reported PMI cannot be applied at the eNB downlink before SF#(n+4).			

Table 8.2.1.4.2A-2: Enhanced Performance Requirement Type C for Multi-Layer Spatial Multiplexing with TM4 (FRC)

Test number	Bandwidth	Reference Channel	OCNG Pattern	Propagation Condition	Correlation Matrix and Antenna Configuration	Reference value		UE Category
						Fraction of Maximum Throughput (%)	SNR (dB)	
1	10 MHz	R.11 FDD	OP.1 FDD	ETU70	2x2 Medium	70	18.3	≥ 2

8.2.1.4.3 Minimum Requirement Multi-Layer Spatial Multiplexing 4 Tx Antenna Port

For single carrier, the requirements are specified in Table 8.2.1.4.3-2, with the addition of the parameters in Table 8.2.1.4.3-1 and the downlink physical channel setup according to Annex C.3.2.

For CA with 2 DL CCs, the requirements are specified in Table 8.2.1.4.3-4, with the addition of the parameters in Table 8.2.1.4.3-3 and the downlink physical channel setup according to Annex C.3.2. The purpose of these tests is to verify the closed loop rank-two performance with wideband and frequency selective precoding.

For CA with 3 DL CCs, the requirements are specified in Table 8.2.1.4.3-6, based on single carrier requirement specified in Table 8.2.1.4.3-5, with the addition of the parameters in Table 8.2.1.4.3-3 and the downlink physical channel setup according to Annex C.3.2.

The test coverage for different number of component carriers is defined in 8.1.2.4.

Table 8.2.1.4.3-1: Test Parameters for Multi-Layer Spatial Multiplexing (FRC)

Parameter	Unit	Test 1	
Downlink power allocation	ρ_A	dB	-6
	ρ_B	dB	-6 (Note 1)
	σ	dB	3
N_{oc} at antenna port	dBm/15kHz	-98	
Precoding granularity	PRB	6	
PMI delay (Note 2)	ms	8	
Reporting interval	ms	1	
Reporting mode		PUSCH 1-2	
CodeBookSubsetRestriction bitmap		00000000000000000000000000000000 000011111111111111111100000000 00000000	
PDSCH transmission mode		4	
Note 1: $P_B = 1$. Note 2: If the UE reports in an available uplink reporting instance at subframe SF#n based on PMI estimation at a downlink SF not later than SF#(n-4), this reported PMI cannot be applied at the eNB downlink before SF#(n+4). Note 3: Void. Note 4: Void. Note 5: Void.			

Table 8.2.1.4.3-2: Minimum performance Multi-Layer Spatial Multiplexing (FRC)

Test num.	Bandwidth	Reference channel	OCNG pattern	Propagation condition	Correlation matrix and antenna config.	Reference value		UE category
						Fraction of maximum throughput (%)	SNR (dB)	
1	10 MHz	R.36 FDD	OP.1 FDD	EPA5	4x2 Low	70	14.7	≥ 2
Note 1: Void.								

Table 8.2.1.4.3-3: Test Parameters for Multi-Layer Spatial Multiplexing (FRC) for CA

Parameter	Unit	Value
Downlink power allocation	ρ_A	dB
	ρ_B	dB
	σ	dB
N_{oc} at antenna port	dBm/15kHz	-98
Precoding granularity	PRB	4 for 3MHz and 5MHz CCs, 6 for 10MHz CCs, 8 for 15MHz and 20MHz CCs
PMI delay (Note 2)	ms	8
Reporting interval	ms	1
Reporting mode		PUSCH 1-2
CodeBookSubsetRestriction bitmap		00000000000000000000000000000000 0011111111111111111111000000000000 0000
CSI request field (Note 3)		'10'
PDSCH transmission mode		4
Note 1: $P_B = 1$. Note 2: If the UE reports in an available uplink reporting instance at subframe SF#n based on PMI estimation at a downlink SF not later than SF#(n-4), this reported PMI cannot be applied at the eNB downlink before SF#(n+4). Note 3: Multiple CC-s under test are configured as the 1 st set of serving cells by higher layers. Note 4: ACK/NACK bits are transmitted using PUSCH with PUCCH format 1b with channel selection configured for Tests in Table 8.2.1.4.3-4, and with PUCCH format 3 for Tests in Table 8.2.1.4.3-6. Note 5: The same PDSCH transmission mode is applied to each component carrier.		

Table 8.2.1.4.3-4: Minimum performance Multi-Layer Spatial Multiplexing (FRC) for CA with 2DL CCs

Test num	Band-width	Reference channel	OCNG pattern	Propa-gation condition	Correlation matrix and antenna config.	Reference value		UE cate-gory
						Fraction of maximum throughput (%)	SNR (dB)	
1	2x10 MHz	R.14 FDD	OP.1 FDD (Note 1)	EVA5	4x2 Low	70	10.8	≥3
2	2x20 MHz	R.14-3 FDD	OP.1 FDD (Note 1)	EVA5	4x2 Low	70	10.9	≥5
3	2x5 MHz	R.14-6 FDD	OP.1 FDD (Note 1)	EVA5	4x2 Low	70	9.5	≥2
			OP.1 FDD (Note 1)			70	9.5	
4	10MHz+5 MHz	R.14 FDD for 10MHz CC	OP.1 FDD (Note 1)	EVA5	4x2 Low	70	10.1	≥3
		R.14-6 FDD for 5MHz CC	OP.1 FDD (Note 1)			70	9.5	
Note 1: The OCNG pattern applies for each CC. Note 2: The applicability of requirements for different CA configurations and bandwidth combination sets is defined in 8.1.2.3.								

Table 8.2.1.4.3-5: Single carrier performance for multiple CA configurations

Band-width	Reference channel	OCNG pattern	Propagation condition	Correlation matrix and antenna config.	Reference value	
					Fraction of maximum throughput (%)	SNR (dB)
1.4MHz	R.14-4 FDD	OP.1 FDD	EVA5	4x2 Low	70	10.4
3MHz	R.14-5 FDD	OP.1 FDD	EVA5	4x2 Low	70	9.5
5MHz	R.14-6 FDD	OP.1 FDD	EVA5	4x2 Low	70	9.5
10 MHz	R.14 FDD	OP.1 FDD	EVA5	4x2 Low	70	10.1
15MHz	R.14-7 FDD	OP.1 FDD	EVA5	4x2 Low	70	10.1
20MHz	R.14-3 FDD	OP.1 FDD	EVA5	4x2 Low	70	10.3

Table 8.2.1.4.3-6: Minimum performance (FRC) based on single carrier performance for CA with 3 DL CCs

Test num.	CA Band-width combination	Requirement	UE category
1	3x20MHz	As specified in Table 8.2.1.4.3-5 per CC	≥5
2	20MHz+20MHz+15MHz	As specified in Table 8.2.1.4.3-5 per CC	≥5
3	20MHz+20MHz+10MHz	As specified in Table 8.2.1.4.3-5 per CC	≥5
4	20MHz+15MHz+15MHz	As specified in Table 8.2.1.4.3-5 per CC	≥5
5	20MHz+15MHz+10MHz	As specified in Table 8.2.1.4.3-5 per CC	≥5
6	20MHz+10MHz+10MHz	As specified in Table 8.2.1.4.3-5 per CC	≥5
7	15MHz+15MHz+10MHz	As specified in Table 8.2.1.4.3-5 per CC	≥5
8	20MHz+10MHz+5MHz	As specified in Table 8.2.1.4.3-5 per CC	≥5
Note 1:	The applicability of requirements for different CA configurations and bandwidth combination sets is defined in 8.1.2.3		

8.2.1.4.3A Minimum Requirement Multi-Layer Spatial Multiplexing 4 Tx Antenna Port for dual connectivity

For dual connectivity the requirements are specified in Table 8.2.1.4.3A-3, based on single carrier requirement specified in Table 8.2.1.4.3A-2, with the addition of the parameters in Table 8.2.1.4.3A-1 and the downlink physical channel setup according to Annex C.3.2. The purpose of these tests is to verify the closed loop rank-two performance with wideband and frequency selective precoding by using dual connectivity transmission.

Table 8.2.1.4.3A-1: Test Parameters for Multi-Layer Spatial Multiplexing (FRC) for dual connectivity

Parameter		Unit	Values
Downlink power allocation	ρ_A	dB	-6
	ρ_B	dB	-6 (Note 1)
	σ	dB	3
N_{oc} at antenna port		dBm/15kHz	-98
Precoding granularity		PRB	6 for 1.4MHz, 4 for 3MHz and 5MHz CCs, 6 for 10MHz CCs, and 8 for 15MHz CCs and 20MHz CCs
PMI delay (Note 2)		ms	8
Reporting interval		ms	1
Reporting mode			PUSCH 1-2
CodeBookSubsetRestriction bitmap			00000000000000000000000000000000 00001111111111111111100000000 00000000
PDSCH transmission mode			4
ACK/NACK transmission			Separate ACK/NACK feedbacks with PUCCH format 1b on the MCG and SCG
CSI feedback			Separate PUSCH feedbacks on the MCG and SCG
Time offset between MCG CC and SCG CC		μ s	0 for UE under test supporting synchronous dual connectivity; 334 for UE under test supporting both asynchronous and synchronous dual connectivity (Note 4)
<p>Note 1: $P_B = 1$.</p> <p>Note 2: If the UE reports in an available uplink reporting instance at subframe SF#n based on PMI estimation at a downlink SF not later than SF#(n-4), this reported PMI cannot be applied at the eNB downlink before SF#(n+4).</p> <p>Note 3: The same PDSCH transmission mode is applied to each component carrier.</p> <p>Note 4: As defined in TS36.300 [11].</p> <p>Note 5: If the UE supports both SCG bearer and Split bearer, the SCG bearer is configured.</p>			

Table 8.2.1.4.3A-2: Single carrier performance for multiple dual connectivity configurations

Bandwidth	Reference channel	OCNG pattern	Propagation condition	Correlation matrix and antenna config.	Reference value	
					Fraction of maximum throughput (%)	SNR (dB)
1.4MHz	R.14-4 FDD	OP. 1 FDD	EVA5	4x2 Low	70	10.36
3MHz	R.14-5 FDD	OP. 1 FDD	EVA5	4x2 Low	70	9.5
5MHz	R.14-6 FDD	OP. 1 FDD	EVA5	4x2 Low	70	9.5
10 MHz	R.14 FDD	OP. 1 FDD	EVA5	4x2 Low	70	10.1
15MHz	R.14-7 FDD	OP. 1 FDD	EVA5	4x2 Low	70	10.1
20MHz	R.14-3 FDD	OP. 1 FDD	EVA5	4x2 Low	70	10.3

Table 8.2.1.4.3A-3: Minimum performance Multi-Layer Spatial Multiplexing (FRC) for dual connectivity

Test num.	Band-width combination	Requirement	UE category
1	2x20 MHz	As specified in Table 8.2.1.4.3A-2 per CC	≥5
2	15+20 MHz	As specified in Table 8.2.1.4.3A-2 per CC	≥5
3	10+20MHz	As specified in Table 8.2.1.4.3A-2 per CC	≥5
4	2x15 MHz	As specified in Table 8.2.1.4.3A-2 per CC	≥5
5	2x10 MHz	As specified in Table 8.2.1.4.3A-2 per CC	≥3

Note 1: The OCNG pattern applies for each CC.
Note 2: The applicability of requirements for different dual connectivity configurations and bandwidth combination sets is defined in 8.1.2.3A.

8.2.1.5 MU-MIMO

8.2.1.6 [Control channel performance: D-BCH and PCH]

8.2.1.7 Carrier aggregation with power imbalance

For CA, the requirements in this section verify the ability of an intraband adjacent carrier aggregation UE to demodulate the signal transmitted by the PCell or SCell in the presence of a stronger SCell or PCell signal on an adjacent frequency. Throughput is measured on the PCell or SCell only.

8.2.1.7.1 Minimum Requirement

The requirements are specified in Table 8.2.1.7.1-2, with the addition of the parameters in Table 8.2.1.7.1-1 and the downlink physical channel setup according to Annex C.3.2.

Table 8.2.1.7.1-1: Test Parameters for CA

Parameter		Unit	Test 1	Test 2-3
Downlink power allocation	ρ_A	dB	0	0
	ρ_B	dB	0 (Note 1)	0 (Note 1)
	σ	dB	0	0
N_{oc} at antenna port		dBm/15kHz	Off (Note 2)	Off (Note 2)
Symbols for unused PRBs			OCNG (Note 3)	OCNG (Note 3)
Modulation			64 QAM	64 QAM
Maximum number of HARQ transmission			1	1
Redundancy version coding sequence			{0}	{0}
PDSCH transmission mode of PCell			1	3
PDSCH transmission mode of SCell			3	1
OCNG Pattern	PCell		OP.1 FDD	OP.5 FDD
	SCell		OP.5 FDD	OP.1 FDD
Propagation Conditions	PCell		Clause B.1	Clause B.1
	SCell		Clause B.1	Clause B.1
Correlation Matrix and Antenna	PCell		1x2	2x2
	SCell		2x2	1x2
Note 1: $P_B = 0$ for 1x2 and $P_B = 1$ for 2x2 antenna configuration.				
Note 2: No external noise sources are applied				
Note 3: These physical resource blocks are assigned to an arbitrary number of virtual UEs with one PDSCH per virtual UE; the data transmitted over the OCNG PDSCHs shall be uncorrelated. pseudo random data.				
Note 4: Void				

Table 8.2.1.7.1-2: Minimum performance (FRC) for CA

Test Number	Bandwidth (MHz)		Reference channel		Power at antenna port (dBm/15KHz)		Reference value Fraction of Maximum Throughput (%)		UE Category
	PCell	SCell	PCell	SCell	\hat{E}_{s_PCell} for PCell	\hat{E}_{s_SCell} for SCell	PCell	SCell	
1	20	20	R.49 FDD	NA	-85	-79	85	NA	≥ 5
2	10	10	NA	R.49-1 FDD	-79	-85.8	NA	85	≥ 5
3	5	5	NA	R.49-2 FDD	-79	-85.9	NA	85	≥ 5
Note 1:	The OCNG pattern for PCell is used to fill the control channel. The OCNG pattern for SCell is used to fill the control channel and PDSCH.								
Note 2:	The applicability of requirements for different CA configurations and bandwidth combination sets is defined in 8.1.2.3.								

8.2.1.8 Intra-band non-contiguous carrier aggregation with timing offset

The requirements in this section verify the ability of an intraband non-contiguous carrier aggregation UE to demodulate the signal transmitted by the PCell and SCell in the presence of timing offset between the cells. Throughput is measured on both cells.

8.2.1.8.1 Minimum Requirement

For CA the requirements are specified in Table 8.2.1.8.1-2, with the addition of the parameters in Table 8.2.1.8.1-1 and the downlink physical channel setup according to Annex C.3.2.

Table 8.2.1.8.1-1: Test Parameters for CA

Parameter	Unit	Test 1	
Downlink power allocation	ρ_A	dB	-3
	ρ_B	dB	-3 (Note 1)
	σ	dB	0
N_{oc} at antenna port	dBm/15kHz	-98	
Modulation		64 QAM	
Maximum number of HARQ transmission		4	
Redundancy version coding sequence		{0,0,1,2}	
PDSCH transmission mode of PCell		3	
PDSCH transmission mode of SCell		3	
Note 1:	$P_B = 1$.		
Note 2:	The OCNG pattern is used to fill unused control channel and PDSCH.		

Table 8.2.1.8.1-2: Minimum performance (FRC) for CA

Test Number	Cell	Bandwidth	Reference Channel	OCNG Pattern	Propagation Conditions	Correlation Matrix and Antenna	Reference value		Timing relative to PCell (μ s)	UE Category
							Fraction of Maximum Throughput (%)	SNR (dB)		
1	PCell	10MHz	R.35-4 FDD	OP.1 FDD	EPA200	2x2 Low	70	21.15	N/A	≥ 3
	SCell	10MHz	R.35-3 FDD		EPA200	2x2 Low	60	15.18	-30.26	
Note 1: The EPA200 propagation channels applied to PCell and SCell are statistically independent. Note 2: The applicability and test rules of requirements for different CA configurations and bandwidth combination sets are defined in 8.1.2.3.										

8.2.2 TDD (Fixed Reference Channel)

The parameters specified in Table 8.2.2-1 are valid for all TDD tests unless otherwise stated.

Table 8.2.2-1: Common Test Parameters (TDD)

Parameter	Unit	Value
Uplink downlink configuration (Note 1)		1
Special subframe configuration (Note 2)		4
Cyclic prefix		Normal
Cell ID		0
Inter-TTI Distance		1
Number of HARQ processes per component carrier	Processes	7
Maximum number of HARQ transmission		4
Redundancy version coding sequence		{0,1,2,3} for QPSK and 16QAM {0,0,1,2} for 64QAM and 256QAM
Number of OFDM symbols for PDCCH per component carrier	OFDM symbols	4 for 1.4 MHz bandwidth, 3 for 3 MHz and 5 MHz bandwidths, 2 for 10 MHz, 15 MHz and 20 MHz bandwidths unless otherwise stated
Cross carrier scheduling		Not configured
Note 1: as specified in Table 4.2-2 in TS 36.211 [4].		
Note 2: as specified in Table 4.2-1 in TS 36.211 [4].		

8.2.2.1 Single-antenna port performance

The single-antenna performance in a given multi-path fading environments is determined by the SNR for which a certain relative information bit throughput of the reference measurement channels in Annex A.3.4 is achieved. The purpose of these tests is to verify the single-antenna performance with different channel models and MCS. The QPSK and 64QAM cases are also used to verify the performance for all bandwidths specified in Table 5.6.1-1.

8.2.2.1.1 Minimum Requirement

For single carrier, the requirements are specified in Table 8.2.2.1.1-2, with the addition of the parameters in Table 8.2.2.1.1-1 and the downlink physical channel setup according to Annex C.3.2.

For CA with 2 DL CCs, the requirements are specified in Table 8.2.2.1.1-4, with the addition of the parameters in Table 8.2.2.1.1-3 and the downlink physical channel setup according to Annex C.3.2.

For CA with 3 DL CCs, the requirements are specified in Table 8.2.2.1.1-7, based on single carrier requirement specified in Table 8.2.2.1.1-5, with the addition of the parameters in Table 8.2.2.1.1-3 and the downlink physical channel setup according to Annex C.3.2.

The test coverage for different number of component carriers is defined in 8.1.2.4.

Table 8.2.2.1.1-1: Test Parameters

Parameter		Unit	Test 1- 5	Test 6- 8	Test 9- 15	Test 16- 18	Test 19
Downlink power allocation	ρ_A	dB	0	0	0	0	0
	ρ_B	dB	0 (Note 1)	0 (Note 1)	0 (Note 1)	0 (Note 1)	0 (Note 1)
	σ	dB	0	0	0	0	0
N_{oc} at antenna port		dBm/15kHz	-98	-98	-98	-98	-98
Symbols for unused PRBs			OCNG (Note 2)	OCNG (Note 2)	OCNG (Note 2)	OCNG (Note 2)	OCNG (Note 2)
Modulation			QPSK	16QAM	64QAM	16QAM	QPSK
ACK/NACK feedback mode			Multiplexing	Multiplexing	Multiplexing	Multiplexing	Multiplexing
PDSCH transmission mode			1	1	1	1	1
Note 1: $P_B = 0$ Note 2: These physical resource blocks are assigned to an arbitrary number of virtual UEs with one PDSCH per virtual UE; the data transmitted over the OCNG PDSCHs shall be uncorrelated pseudo random data, which is QPSK modulated. Note 3: Void Note 4: Void							

Table 8.2.2.1.1-2: Minimum performance (FRC)

Test number	Bandwidth	Reference Channel	OCNG Pattern	Propagation Condition	Correlation Matrix and Antenna Configuration	Reference value		UE Category
						Fraction of Maximum Throughput (%)	SNR (dB)	
1	10 MHz	R.2 TDD	OP.1 TDD	EVA5	1x2 Low	70	-1.2	≥1
2	10 MHz	R.2 TDD	OP.1 TDD	ETU70	1x2 Low	70	-0.6	≥1
3	10 MHz	R.2 TDD	OP.1 TDD	ETU300	1x2 Low	70	-0.2	≥1
4	10 MHz	R.2 TDD	OP.1 TDD	HST	1x2	70	-2.6	≥1
5	1.4 MHz	R.4 TDD	OP.1 TDD	EVA5	1x2 Low	70	0.0	≥1
6	10 MHz	R.3 TDD	OP.1 TDD	EVA5	1x2 Low	70	6.7	≥2
	5 MHz	R.3-1 TDD	OP.1 TDD	EVA5	1x2 Low	70	6.7	1
7	10 MHz	R.3 TDD	OP.1 TDD	ETU70	1x2 Low	30	1.4	≥2
	5 MHz	R.3-1 TDD	OP.1 TDD	ETU70	1x2 Low	30	1.4	1
8	10 MHz	R.3 TDD	OP.1 TDD	ETU300	1x2 High	70	9.3	≥2
	5 MHz	R.3-1 TDD	OP.1 TDD	ETU300	1x2 High	70	9.3	1
9	3 MHz	R.5 TDD	OP.1 TDD	EVA5	1x2 Low	70	17.6	≥1
10	5 MHz	R.6 TDD	OP.1 TDD	EVA5	1x2 Low	70	17.6	≥2
	5 MHz	R.6-1 TDD	OP.1 TDD	EVA5	1x2 Low	70	17.6	1
11	10 MHz	R.7 TDD	OP.1 TDD	EVA5	1x2 Low	70	17.6	≥2
	10 MHz	R.7-1 TDD	OP.1 TDD	EVA5	1x2 Low	70	17.6	1
12	10 MHz	R.7 TDD	OP.1 TDD	ETU70	1x2 Low	70	19.1	≥2
	10 MHz	R.7-1 TDD	OP.1 TDD	ETU70	1x2 Low	70	19.1	1
13	10 MHz	R.7 TDD	OP.1 TDD	EVA5	1x2 High	70	19.1	≥2
	10 MHz	R.7-1 TDD	OP.1 TDD	EVA5	1x2 High	70	19.1	1
14	15 MHz	R.8 TDD	OP.1 TDD	EVA5	1x2 Low	70	17.8	≥2
	15 MHz	R.8-1 TDD	OP.1 TDD	EVA5	1x2 Low	70	17.8	1
15	20 MHz	R.9 TDD	OP.1 TDD	EVA5	1x2 Low	70	17.7	≥3
	20 MHz	R.9-2 TDD	OP.1 TDD	EVA5	1x2 Low	70	17.7	2
	20 MHz	R.9-1 TDD	OP.1 TDD	EVA5	1x2 Low	70	17.7	1
16	3 MHz	R.0 TDD	OP.1 TDD	ETU70	1x2 Low	30	2.1	≥1
17	10 MHz	R.1 TDD	OP.1 TDD	ETU70	1x2 Low	30	2.0	≥1
18	20 MHz	R.1 TDD	OP.1 TDD	ETU70	1x2 Low	30	2.1	≥1
19	10 MHz	R.41 TDD	OP.1 TDD	EVA5	1x2 Low	70	-5.3	≥1

Note 1: Void.

Table 8.2.2.1.1-3: Test Parameters for CA

Parameter		Unit	Value
Downlink power allocation	ρ_A	dB	0
	ρ_B	dB	0 (Note 1)
	σ	dB	0
N_{oc} at antenna port		dBm/15kHz	-98
Symbols for unused PRBs			OCNG (Note 2)
Modulation			QPSK
ACK/NACK feedback mode			PUCCH format 1b with channel selection for Tests in Table 8.2.2.1.1-4; PUCCH format 3 for Tests in Table 8.2.2.1.1-7
PDSCH transmission mode			1
Note 1: $P_B = 0$			
Note 2: These physical resource blocks are assigned to an arbitrary number of virtual UEs with one PDSCH per virtual UE; the data transmitted over the OCNG PDSCHs shall be uncorrelated pseudo random data, which is QPSK modulated.			
Note 3: The same PDSCH transmission mode is applied to each component carrier.			

Table 8.2.2.1.1-4: Minimum performance (FRC) for CA with 2DL CCs

Test number	Bandwidth	Reference Channel	OCNG Pattern	Propagation Condition	Correlation Matrix and Antenna Configuration	Reference value		UE Category
						Fraction of Maximum Throughput (%)	SNR (dB)	
1	2x20MHz	R.42 TDD	OP.1 TDD (Note 1)	EVA5	1x2 Low	70	-1.2	≥5
2	20MHz+15MHz	R.42 TDD for 20MHz CC	OP.1 TDD (Note 1)	EVA5	1x2 Low	70	-1.4	≥5
		R.42-3 TDD for 15MHz CC	OP.1 TDD (Note 1)			70	-1.4	
Note 1: The OCNG pattern applies for each CC.								
Note 2: The applicability of requirements for different CA configurations and bandwidth combination sets is defined in 8.1.2.3.								
Note 3: 30usec timing difference between PCell and any SCell is applied in inter-band CA case, where PCell can be assigned on any CC.								

Table 8.2.2.1.1-5: Single carrier performance for multiple CA configurations

Band-width	Reference channel	OCNG pattern	Propa-gation condi-tion	Correlation matrix and antenna config.	Reference value	
					Fraction of maximum throughput (%)	SNR (dB)
1.4MHz	R.4 TDD	OP.1 TDD	EVA5	1x2 Low	70	-0.6
3MHz	R.42-1 TDD	OP.1 TDD	EVA5	1x2 Low	70	-0.8
5MHz	R.42-2 TDD	OP.1 TDD	EVA5	1x2 Low	70	-1.2
10MHz	R.2 TDD	OP.1 TDD	EVA5	1x2 Low	70	-1.6
15MHz	R.42-3 TDD	OP.1 TDD	EVA5	1x2 Low	70	-1.4
20MHz	R.42 TDD	OP.1 TDD	EVA5	1x2 Low	70	-1.4

Table 8.2.2.1.1-6: Void

Table 8.2.2.1.1-7: Minimum performance (FRC) based on single carrier performance for CA with 3 DL CCs

Test num.	CA Band-width combination	Requirement	UE category
1	3x20MHz	As specified in Table 8.2.2.1.1-5 per CC	≥5
2	20MHz+20MHz+15MHz	As specified in Table 8.2.2.1.1-5 per CC	≥5
Note 1: The applicability of requirements for different CA configurations and bandwidth combination sets is defined in 8.1.2.3			
Note 2: 30usec timing difference between PCell and any SCell is applied in inter-band CA case, where PCell can be assigned on any CC.			

8.2.2.1.2 Void

8.2.2.1.3 Void

8.2.2.1.4 Minimum Requirement 1 PRB allocation in presence of MBSFN

The requirements are specified in Table 8.2.2.1.4-2, with the addition of the parameters in Table 8.2.2.1.4-1 and the downlink physical channel setup according to Annex C.3.2. The purpose of these tests is to verify the single-antenna performance with a single PRB allocated at the lower band edge in presence of MBSFN.

Table 8.2.2.1.4-1: Test Parameters for Testing 1 PRB allocation

Parameter	Unit	Test 1	
Downlink power allocation	ρ_A	dB	0
	ρ_B	dB	0 (Note 1)
	σ	dB	0
N_{oc} at antenna port	dBm/15kHz	-98	
Symbols for MBSFN portion of MBSFN subframes (Note 2)		OCNG (Note 3)	
ACK/NACK feedback mode		Multiplexing	
PDSCH transmission mode		1	
Note 1: $P_B = 0$ Note 2: The MBSFN portion of an MBSFN subframe comprises the whole MBSFN subframe except the first two symbols in the first slot. Note 3: The MBSFN portion of the MBSFN subframes shall contain QPSK modulated data. Cell-specific reference signals are not inserted in the MBSFN portion of the MBSFN subframes, QPSK modulated MBSFN data is used instead.			

Table 8.2.2.1.4-2: Minimum performance 1PRB (FRC)

Test number	Bandwidth	Reference Channel	OCNG Pattern	Propagation Condition	Correlation Matrix and Antenna Configuration	Reference value		UE Category
						Fraction of Maximum Throughput (%)	SNR (dB)	
1	10 MHz	R.29 TDD	OP.3 TDD	ETU70	1x2 Low	30	2.0	≥1

8.2.2.2 Transmit diversity performance

8.2.2.2.1 Minimum Requirement 2 Tx Antenna Port

The requirements are specified in Table 8.2.2.2.1-2, with the addition of the parameters in Table 8.2.2.2.1-1 and the downlink physical channel setup according to Annex C.3.2. The purpose is to verify the performance of transmit diversity (SFBC) with 2 transmitter antennas.

Table 8.2.2.2.1-1: Test Parameters for Transmit diversity Performance (FRC)

Parameter		Unit	Test 1-2
Downlink power allocation	ρ_A	dB	-3
	ρ_B	dB	-3 (Note 1)
	σ	dB	0
N_{oc} at antenna port		dBm/15kHz	-98
ACK/NACK feedback mode			Multiplexing
PDSCH transmission mode			2
Note 1: $P_B = 1$			

Table 8.2.2.2.1-2: Minimum performance Transmit Diversity (FRC)

Test number	Bandwidth	Reference Channel	OCNG Pattern	Propagation Condition	Correlation Matrix and Antenna Configuration	Reference value		UE Category
						Fraction of Maximum Throughput (%)	SNR (dB)	
1	10 MHz	R.11 TDD	OP.1 TDD	EVA5	2x2 Medium	70	6.8	≥ 2
	5 MHz	R.11-2 TDD	OP.1 TDD	EVA5	2x2 Medium	70	6.8	1
2	10 MHz	R.10 TDD	OP.1 TDD	HST	2x2	70	-2.3	≥ 1

8.2.2.2.2 Minimum Requirement 4 Tx Antenna Port

The requirements are specified in Table 8.2.2.2.2-2, with the addition of the parameters in Table 8.2.2.2.2-1 and the downlink physical channel setup according to Annex C.3.2. The purpose is to verify the performance of transmit diversity (SFBC-FSTD) with 4 transmitter antennas.

Table 8.2.2.2.2-1: Test Parameters for Transmit diversity Performance (FRC)

Parameter		Unit	Test 1-2
Downlink power allocation	ρ_A	dB	-3
	ρ_B	dB	-3 (Note 1)
	σ	dB	0
N_{oc} at antenna port		dBm/15kHz	-98
ACK/NACK feedback mode			Multiplexing
PDSCH transmission mode			2
Note 1: $P_B = 1$			

Table 8.2.2.2-2: Minimum performance Transmit Diversity (FRC)

Test number	Band-width	Reference Channel	OCNG Pattern	Propagation Condition	Correlation Matrix and Antenna Configuration	Reference value		UE Category
						Fraction of Maximum Throughput (%)	SNR (dB)	
1	1.4 MHz	R.12 TDD	OP.1 TDD	EPA5	4x2 Medium	70	0.2	≥ 1
2	10 MHz	R.13 TDD	OP.1 TDD	ETU70	4x2 Low	70	-0.5	≥ 1

8.2.2.2.3 Minimum Requirement 2 Tx Antenna Port (demodulation subframe overlaps with aggressor cell ABS)

The requirements are specified in Table 8.2.2.2.3-2, with the addition of parameters in Table 8.2.2.2.3-1 and the downlink physical channel setup according to Annex C.3.2 and Annex C.3.3. The purpose is to verify the performance of transmit diversity (SFBC) with 2 transmit antennas if the PDSCH transmission in the serving cell takes place in subframes that overlap with ABS [9] of the aggressor cell. In Table 8.2.2.2.3-1, Cell 1 is the serving cell, and Cell 2 is the aggressor cell. The downlink physical channel setup for Cell 1 is according to Annex C.3.2 and for Cell 2 is according to Annex C.3.3, respectively.

Table 8.2.2.3-1: Test Parameters for Transmit diversity Performance (FRC)

Parameter		Unit	Cell 1	Cell 2
Uplink downlink configuration			1	1
Special subframe configuration			4	4
Downlink power allocation	ρ_A	dB	-3	-3
	ρ_B	dB	-3 (Note 1)	-3 (Note 1)
	σ	dB	0	N/A
N_{oc} at antenna port	N_{oc1}	dBm/15kHz	-102 (Note 2)	N/A
	N_{oc2}	dBm/15kHz	-98 (Note 3)	N/A
	N_{oc3}	dBm/15kHz	-94.8 (Note 4)	N/A
\hat{E}_s / N_{oc2}		dB	Reference Value in Table 8.2.2.3-2	6
$BW_{Channel}$		MHz	10	10
Subframe Configuration			Non-MBSFN	Non-MBSFN
Time Offset between Cells		μs	2.5 (synchronous cells)	
Cell Id			0	1
ABS pattern (Note 5)			N/A	0000010001 0000000001
RLM/RRM Measurement Subframe Pattern (Note 6)			0000000001 0000000001	N/A
CSI Subframe Sets (Note 7)	$C_{CSI,0}$		0000010001 0000000001	N/A
	$C_{CSI,1}$		1100101000 1100111000	N/A
Number of control OFDM symbols			2	2
ACK/NACK feedback mode			Multiplexing	N/A
PDSCH transmission mode			2	N/A
Cyclic prefix			Normal	Normal
<p>Note 1: $P_B = 1$.</p> <p>Note 2: This noise is applied in OFDM symbols #1, #2, #3, #5, #6, #8, #9, #10, #12, #13 of a subframe overlapping with the aggressor ABS.</p> <p>Note 3: This noise is applied in OFDM symbols #0, #4, #7, #11 of a subframe overlapping with the aggressor ABS.</p> <p>Note 4: This noise is applied in all OFDM symbols of a subframe overlapping with aggressor non-ABS.</p> <p>Note 5: ABS pattern as defined in [9].</p> <p>Note 6: Time-domain measurement resource restriction pattern for PCell measurements as defined in [7].</p> <p>Note 7: As configured according to the time-domain measurement resource restriction pattern for CSI measurements defined in [7].</p> <p>Note 8: Cell 1 is the serving cell. Cell 2 is the aggressor cell. The number of the CRS ports in Cell1 and Cell2 is the same.</p> <p>Note 9: SIB-1 will not be transmitted in Cell2 in this test.</p>				

Table 8.2.2.3-2: Minimum Performance Transmit Diversity (FRC)

Test Number	Reference Channel	OCNG Pattern		Propagation Conditions (Note 1)		Correlation Matrix and Antenna Configuration	Reference Value		UE Category
		Cell 1	Cell 2	Cell 1	Cell 2		Fraction of Maximum Throughput (%) Note 5	SNR (dB) (Note 2)	
1	R.11-4 TDD Note 4	OP.1 TDD	OP.1 TDD	EVA5	EVA5	2x2 Medium	70	3.8	≥2
<p>Note 1: The propagation conditions for Cell 1 and Cell2 are statistically independent.</p> <p>Note 2: SNR corresponds to \widehat{E}_s/N_{oc2} of cell 1.</p> <p>Note 3: The correlation matrix and antenna configuration apply for Cell 1 and Cell 2.</p> <p>Note 4: Cell 1 Reference channel is modified: PDSCH other than SIB1/paging and its associated PDCCH/PCFICH are transmitted in the serving cell subframe when the subframe is overlapped with the ABS subframe of aggressor cell and the subframe is available in the definition of the reference channel.</p> <p>Note 5: The maximum Throughput is calculated from the total Payload in 2 subframes, averaged over 20ms.</p>									

8.2.2.3A Minimum Requirement 2 Tx Antenna Ports (demodulation subframe overlaps with aggressor cell ABS and CRS assistance information are configured)

The requirements are specified in Table 8.2.2.3A-2, with the addition of parameters in Table 8.2.2.3A-1. The purpose is to verify the performance of transmit diversity (SFBC) with 2 transmit antennas if the PDSCH transmission in the serving cell takes place in subframes that overlap with ABS [9] of the aggressor cell with CRS assistance information. In Table 8.2.2.3A-1, Cell 1 is the serving cell, and Cell 2 and Cell 3 are the aggressor cells. The downlink physical channel setup for Cell 1 is according to Annex C.3.2 and for Cell 2 and Cell 3 is according to Annex C.3.3, respectively. The CRS assistance information [7] includes Cell 2 and Cell 3.

Table 8.2.2.3A-1: Test Parameters for Transmit diversity Performance (FRC)

Parameter		Unit	Cell 1	Cell 2	Cell 3
Uplink downlink configuration			1	1	1
Special subframe configuration			4	4	4
Downlink power allocation	ρ_A	dB	-3	-3	-3
	ρ_B	dB	-3 (Note 1)	-3 (Note 1)	-3 (Note 1)
	σ	dB	0	N/A	N/A
N_{oc} at antenna port	N_{oc1}	dBm/15kHz	-98 (Note 2)	N/A	N/A
	N_{oc2}	dBm/15kHz	-98 (Note 3)	N/A	N/A
	N_{oc3}	dBm/15kHz	-93 (Note 4)	N/A	N/A
\hat{E}_s / N_{oc2}		dB	Reference Value in Table 8.2.2.3A-2	12	10
BW _{Channel}		MHz	10	10	10
Subframe Configuration			Non-MBSFN	Non-MBSFN	Non-MBSFN
Time Offset between Cells		μs	N/A	3	-1
Frequency shift between Cells		Hz	N/A	300	-100
Cell Id			0	126	1
ABS pattern (Note 5)			N/A	0000000001 0000000001	0000000001 0000000001
RLM/RRM Measurement Subframe Pattern (Note 6)			0000000001 0000000001	N/A	N/A
CSI Subframe Sets (Note7)	C _{CSI,0}		0000000001 0000000001	N/A	N/A
	C _{CSI,1}		1100111000 1100111000	N/A	N/A
Number of control OFDM symbols			2	Note 8	Note 8
ACK/NACK feedback mode			Multiplexing	N/A	N/A
PDSCH transmission mode			2	Note 9	Note 9
Cyclic prefix			Normal	Normal	Normal
<p>Note 1: $P_B = 1$.</p> <p>Note 2: This noise is applied in OFDM symbols #1, #2, #3, #5, #6, #8, #9, #10, #12, #13 of a subframe overlapping with the aggressor ABS.</p> <p>Note 3: This noise is applied in OFDM symbols #0, #4, #7, #11 of a subframe overlapping with the aggressor ABS.</p> <p>Note 4: This noise is applied in all OFDM symbols of a subframe overlapping with aggressor non-ABS</p> <p>Note 5: ABS pattern as defined in [9].</p> <p>Note 6: Time-domain measurement resource restriction pattern for PCell measurements as defined in [7]</p> <p>Note 7: As configured according to the time-domain measurement resource restriction pattern for CSI measurements defined in [7].</p> <p>Note 8: The number of control OFDM symbols is not available for ABS and is 2 for the subframe indicated by "0" of ABS pattern.</p> <p>Note 9: Downlink physical channel setup in Cell 2 and Cell 3 in accordance with Annex C.3.3 applying OCN pattern as defined in Annex A.5.</p> <p>Note 10: The number of the CRS ports in Cell 1, Cell 2 and Cell 3 is the same.</p> <p>Note 11: SIB-1 will not be transmitted in Cell 2 and Cell 3 in this test.</p>					

Table 8.2.2.3A-2: Minimum Performance Transmit Diversity (FRC)

Test Number	Reference Channel	OCNG Pattern			Propagation Conditions (Note 1)			Correlation Matrix and Antenna Configuration (Note 2)	Reference Value		UE Category
		Cell 1	Cell 2	Cell 3	Cell 1	Cell 2	Cell 3		Fraction of Maximum Throughput (%) Note 5	SNR (dB) (Note 3)	
1	R.11-4 TDD Note 4	OP.1 TDD	OP.1 TDD	OP.1 TDD	EVA5	EVA5	EVA5	2x2 Medium	70	3.5	≥2

Note 1: The propagation conditions for Cell 1, Cell 2 and Cell 3 are statistically independent.

Note 2: The correlation matrix and antenna configuration apply for Cell 1, Cell 2 and Cell 3..

Note 3: SNR corresponds to \hat{E}_s / N_{oc2} of cell 1.

Note 4: Cell 1 Reference channel is modified: PDSCH other than SIB1/paging and its associated PDCCH/PCFICH are transmitted in the serving cell subframe when the subframe is overlapped with the ABS subframe of aggressor cell and the subframe is available in the definition of the reference channel.

Note 5: The maximum Throughput is calculated from the total Payload in 2 subframes, averaged over 20ms.

8.2.2.2.4 Enhanced Performance Requirement Type A – 2 Tx Antenna Ports with TM3 interference model

The requirements are specified in Table 8.2.2.2.4-2, with the addition of parameters in Table 8.2.2.2.4-1 and the downlink physical channel setup according to Annex C.3.2. The purpose is to verify the performance of transmit diversity (SFBC) with 2 transmit antennas when the PDSCH transmission in the serving cell is interfered by PDSCH of two dominant interfering cells applying transmission mode 3 interference model defined in clause B.5.2. In Table 8.2.2.2.4-1, Cell 1 is the serving cell, and Cell 2, 3 are interfering cells. The downlink physical channel setup is according to Annex C.3.2 for each of Cell 1, Cell 2 and Cell 3, respectively.

Table 8.2.2.4-1: Test Parameters for Transmit diversity Performance (FRC) with TM3 interference model

Parameter		Unit	Cell 1	Cell 2	Cell 3
Downlink power allocation	ρ_A	dB	-3	-3	-3
	ρ_B	dB	-3 (Note 1)	-3	-3
	σ	dB	0	0	0
Cell-specific reference signals			Antenna ports 0,1	Antenna ports 0,1	Antenna ports 0,1
N_{oc} at antenna port		dBm/15kHz	-98	N/A	N/A
DIP (Note 2)		dB	N/A	-1.73	-8.66
$BW_{Channel}$		MHz	10	10	10
Cyclic Prefix			Normal	Normal	Normal
Cell Id			0	1	2
Number of control OFDM symbols			2	2	2
PDSCH transmission mode			2	N/A	N/A
Interference model			N/A	As specified in clause B.5.2	As specified in clause B.5.2
Probability of occurrence of transmission rank in interfering cells	Rank 1	%	N/A	80	80
	Rank 2	%	N/A	20	20
Reporting interval		ms	5	N/A	N/A
Reporting mode			PUCCH 1-0	N/A	N/A
ACK/NACK feedback mode			Multiplexing	N/A	N/A
Physical channel for CQI reporting			PUSCH(Note 5)	N/A	N/A
cqi-pmi-ConfigurationIndex			4	N/A	N/A
<p>Note 1: $P_B = 1$</p> <p>Note 2: The respective received power spectral density of each interfering cell relative to N_{oc} is defined by its associated DIP value as specified in clause B.5.1.</p> <p>Note 3: Cell 1 is the serving cell. Cell 2, 3 are the interfering cells.</p> <p>Note 4: All cells are time-synchronous.</p> <p>Note 5: To avoid collisions between CQI reports and HARQ-ACK it is necessary to report both on PUSCH instead of PUCCH. PDCCH DCI format 0 shall be transmitted in downlink SF#4 and #9 to allow periodic CQI to multiplex with the HARQ-ACK on PUSCH in uplink subframe SF#8 and #3.</p>					

Table 8.2.2.4-2: Enhanced Performance Requirement Type A, Transmit Diversity (FRC) with TM3 interference model

Test Number	Reference Channel	OCNG Pattern			Propagation Conditions			Correlation Matrix and Antenna Configuration (Note 3)	Reference Value		UE Category
		Cell 1	Cell 2	Cell 3	Cell 1	Cell 2	Cell 3		Fraction of Maximum Throughput (%)	SINR (dB) (Note 2)	
1	R.46 TDD	OP. 1 TD D	N/A	N/A	EV A70	EV A70	EV A70	2x2 Low	70	-1.4	≥1
<p>Note 1: The propagation conditions for Cell 1, Cell 2 and Cell 3 are statistically independent.</p> <p>Note 2: SINR corresponds to \hat{E}_s / N_{oc} of Cell 1 as defined in clause 8.1.1.</p> <p>Note 3: Correlation matrix and antenna configuration parameters apply for each of Cell 1, Cell 2 and Cell 3.</p>											

8.2.2.2.5 Minimum Requirement 2 Tx Antenna Port (when *EIMTA-MainConfigServCell-r12* is configured)

The requirements are specified in Table 8.2.2.2.5-2 with the addition of the parameters in Table 8.2.2.2.5-1 and the downlink physical channel setup according to Annex C.3.2. The test purpose is to verify the performance of transmit diversity (SFBC) with 2 transmitter antennas in case of using eIMTA TDD UL-DL reconfiguration for TDD serving cell(s) via monitoring PDCCH with eIMTA-RNTI on a PCell.

Table 8.2.2.2.5-1: Test Parameters for Transmit diversity Performance (FRC) when *EIMTA-MainConfigServCell-r12* is configured

Parameter		Unit	Value
Downlink power allocation	ρ_A	dB	-3
	ρ_B	dB	-3 (Note 1)
	σ	dB	0
N_{oc} at antenna port		dBm/15kHz	-98
Uplink downlink configuration in SIB1 (Note 2)			0
Downlink HARQ reference configuration (eimta-HarqReferenceConfig-r12) (Note 2)			5
Set of dynamic TDD UL-DL configurations (Notes 2,3)			{0, 1, 2, 3, 4, 5, 6}
Periodicity of monitoring the L1 reconfiguration DCI (eimta-CommandPeriodicity-r12)		ms	10
Set of subframes to monitor the L1 reconfiguration DCI (eimta-CommandSubframeSet-r12) (Note 4)			{0,1,5,6}
Number of DL HARQ processes		Processes	15
PDSCH transmission mode			2
ACK/NACK feedback mode (Note 5)			Multiplexing
Note 1: $P_B = 1$.			
Note 2: As specified in Table 4.2-2 in TS 36.211.			
Note 3: UL/DL configuration in PDCCH with eIMTA-RNTI is randomly selected from the given set on a per-DCI basis with equal probability.			
Note 4: The set of subframes to monitor PDCCH with eIMTA-RNTI for frame n includes subframes {1,5,6} in frame n-1 and subframe 0 in frame n. Subframes for reconfiguration DCI transmission are chosen in a random way on a per-DCI basis with equal probability.			
Note 5: PUCCH Format 3 is used for DL HARQ feedback.			

Table 8.2.2.2.5-2: Minimum performance Transmit diversity when *EIMTA-MainConfigServCell-r12* is configured

Test	Reference channel	OCNG Pattern	Propagation Conditions	Correlation Matrix and Antenna Configuration	Reference value		UE Category
					Fraction of Maximum Throughput (%)	SNR (dB)	
1	R.67 TDD	OP.1 TDD	EVA5	2x2 Medium	70	5.0	≥ 1

8.2.2.2.6 Enhanced Performance Requirement Type B - 2 Tx Antenna Ports with TM2 interference model

The requirements are specified in Table 8.2.2.2.6-2, with the addition of parameters in Table 8.2.2.2.6-1 and the downlink physical channel setup according to Annex C.3.2. The purpose is to verify the performance of transmit diversity (SFBC) with 2 transmit antennas when the PDSCH transmission in the serving cell is interfered by PDSCH of two interfering cells applying transmission mode 2 interference model defined in clause B.6.1. In Table 8.2.2.2.6-1, Cell 1 is the serving cell, and Cell 2, 3 are interfering cells. The downlink physical channel setup is according to Annex C.3.2 for each of Cell 1, Cell 2 and Cell 3, respectively.

Table 8.2.2.6-1: Test Parameters for Transmit Diversity Performance (FRC) with TM2 interference model

Parameter		Unit	Cell 1	Cell 2	Cell 3
Uplink downlink Configuration			1	1	1
Special subframe configuration			4	4	4
Downlink power allocation	ρ_A	dB	-3	-3	-3
	ρ_B	dB	-3 (NOTE 1)	-3	-3
	σ	dB	0	0	0
Cell-specific reference signals			Antenna ports 0,1	Antenna ports 0,1	Antenna ports 0,1
N_{oc} at antenna port		dBm/15kHz	-98		
\hat{E}_s/N_{oc}		dB	N/A	13.91	3.34
BW _{Channel}		MHz	10	10	10
Cyclic Prefix			Normal	Normal	Normal
Cell Id			0	6	1
Number of control OFDM symbols in normal subframes			3	3	3
CFI indicated in PCFICH in normal subframes			3	3	3
Number of control OFDM symbols in special subframes			2	2	2
CFI indicated in PCFICH in special subframes			2	2	2
PDSCH transmission mode			2	2	2
Interference model			N/A	As specified in clause B.6.1	As specified in clause B.6.1
MBSFN			Not configured	Not configured	Not configured
Time offset to cell 1		us	N/A	2	3
Frequency offset to cell 1		Hz	N/A	200	300
NeighCellsInfo-r12 (NOTE 3)	p-aList-r12		N/A	{dB-6, dB-3, dB0}	{dB-6, dB-3, dB0}
	transmissionModeList-r12		N/A	{2,3,4,8,9}	{2,3,4,8,9}
NOTE 1: $P_B = 1$					
NOTE 2: Cell 1 is the serving cell. Cell 2, 3 are the interfering cells.					
NOTE 3: NeighCellsInfo-r12 is described in subclause 6.3.2 of [7].					

Table 8.2.2.6-2: Minimum Performance for Enhanced Performance Requirement Type B, Transmit Diversity (FRC) with TM2 interference model

Test Number	Reference Channel	OCNG Pattern			Propagation Conditions			Correlation Matrix and Antenna Configuration (NOTE 3)	Reference Value		UE Category
		Cell 1	Cell 2	Cell 3	Cell 1	Cell 2	Cell 3		Fraction of Maximum Throughput (%)	SNR (dB) (NOTE 2)	
1	R.11-12 TDD	OP. 1 TD D	N/A	N/A	EP A5	EP A5	EP A5	2x2 Low	85	15.3	≥1
NOTE 1: The propagation conditions for Cell 1, Cell 2 and Cell 3 are statistically independent.											
NOTE 2: SNR corresponds to \hat{E}_s/N_{oc} of Cell 1 as defined in clause 8.1.1.											
NOTE 3: Correlation matrix and antenna configuration parameters apply for each of Cell 1, Cell 2 and Cell 3.											

8.2.2.2.7 Enhanced Performance Requirement Type B - 2 Tx Antenna Ports with TM9 interference model

The requirements are specified in Table 8.2.2.2.7-2, with the addition of parameters in Table 8.2.2.2.7-1 and the downlink physical channel setup according to Annex C.3.2. The purpose is to verify the performance of transmit diversity (SFBC) with 2 transmit antennas when the PDSCH transmission in the serving cell is interfered by PDSCH of two interfering cells applying transmission mode 9 interference model defined in clause B.6.4. In Table 8.2.2.2.7-1, Cell 1 is the serving cell, and Cell 2, 3 are interfering cells. The downlink physical channel setup is according to Annex C.3.2 for each of Cell 1, Cell 2 and Cell 3, respectively.

Table 8.2.2.2.7-1: Test Parameters for Transmit Diversity Performance (FRC) with TM9 interference model

Parameter		Unit	Cell 1	Cell 2	Cell 3
Uplink downlink Configuration			1	1	1
Special subframe configuration			4	4	4
Downlink power allocation	ρ_A	dB	-3	0	0
	ρ_B	dB	-3 (NOTE 1)	0	0
	σ	dB	0	-3	-3
Cell-specific reference signals			Antenna ports 0,1	Antenna ports 0,1	Antenna ports 0,1
N_{oc} at antenna port		dBm/15kHz	-98		
\bar{E}_s/N_{oc}		dB	N/A	3.28	0.74
BW _{Channel}		MHz	10	10	10
Cyclic Prefix			Normal	Normal	Normal
Cell Id			0	1	6
Number of control OFDM symbols in normal subframes			3	3	3
CFI indicated in PCFICH in normal subframes			3	Random from set {1,2,3}	Random from set {1,2,3}
Number of control OFDM symbols in special subframes			2	2	2
CFI indicated in PCFICH in special subframes			2	Random from set {1,2}	Random from set {1,2}
PDSCH transmission mode			2	9	9
Interference model			N/A	As specified in clause B.6.4	As specified in clause B.6.4
CSI reference signals			N/A	Antenna ports 15,16	Antenna ports 15,16
CSI-RS periodicity and subframe offset $T_{CSI-RS} / \Delta_{CSI-RS}$		Subframes	N/A	10 / 4	10 / 4
CSI reference signal configuration			N/A	6	7
Zero-power CSI-RS configuration $I_{CSI-RS} / ZeroPowerCSI-RS$ bitmap		Subframes / bitmap	N/A	9 / 010000000000 0000	9 / 001000000000 0000
Time offset to cell 1		us	N/A	5	-5
Frequency offset to cell 1		Hz	N/A	600	-600
MBSFN			Not configured	Not configured	Not configured
NeighCellsInfo-r12 (NOTE 4)	p-aList-r12		N/A	{dB-6, dB-3, dB0}	{dB-6, dB-3, dB0}
	transmissionModeList-r12		N/A	{2,3,4,8,9}	{2,3,4,8,9}
NOTE 1: $P_B = 1$					
NOTE 2: Cell 1 is the serving cell. Cell 2, 3 are the interfering cells.					
NOTE 3: CSI-RS configurations are according to [4] subclause 6.10.5.2.					
NOTE 4: NeighCellsInfo-r12 is described in subclause 6.3.2 of [7].					

Table 8.2.2.7-2: Minimum Performance for Enhanced Performance Requirement Type B, Transmit Diversity (FRC) with TM9 interference model

Test Number	Reference Channel	OCNG Pattern			Propagation Conditions			Correlation Matrix and Antenna Configuration (NOTE 3)	Reference Value		UE Category
		Cell 1	Cell 2	Cell 3	Cell 1	Cell 2	Cell 3		Fraction of Maximum Throughput (%)	SNR (dB) (NOTE 2)	
1	R.11-11 TDD	OP. 1 TD D	N/A	N/A	EP A5	EP A5	EP A5	2x2 Low	85	8.1	≥1

NOTE 1: The propagation conditions for Cell 1, Cell 2 and Cell 3 are statistically independent.

NOTE 2: SNR corresponds to \hat{E}_s/N_{oc} of Cell 1 as defined in clause 8.1.1.

NOTE 3: Correlation matrix and antenna configuration parameters apply for each of Cell 1, Cell 2 and Cell 3.

8.2.2.3 Open-loop spatial multiplexing performance

8.2.2.3.1 Minimum Requirement 2 Tx Antenna Port

For single carrier, the requirements are specified in Table 8.2.2.3.1-2, with the addition of the parameters in Table 8.2.2.3.1-1 and the downlink physical channel setup according to Annex C.3.2.

For CA with 2 DL CCs, the requirements are specified in Table 8.2.2.3.1-4, with the addition of the parameters in Table 8.2.2.3.1-3 and the downlink physical channel setup according to Annex C.3.2. The purpose is to verify the performance of large delay CDD with 2 transmitter antennas.

For CA with 3 DL CCs, the requirements are specified in Table 8.2.2.3.1-7, based on single carrier requirement specified in Table 8.2.2.3.1-5, with the addition of the parameters in Table 8.2.2.3.1-3 and the downlink physical channel setup according to Annex C.3.2.

The test coverage for different number of component carriers is defined in 8.1.2.4.

Table 8.2.2.3.1-1: Test Parameters for Large Delay CDD (FRC)

Parameter	Unit	Test 1-3
Downlink power allocation	ρ_A	-3
	ρ_B	-3 (Note 1)
	σ	0
N_{oc} at antenna port	dBm/15kHz	-98
ACK/NACK feedback mode		Bundling
PDSCH transmission mode		3
Note 1: $P_B = 1$		
Note 2: Void.		
Note 3: Void.		

Table 8.2.2.3.1-2: Minimum performance Large Delay CDD (FRC)

Test number	Bandwidth	Reference Channel	OCNG Pattern	Propagation Condition	Correlation Matrix and Antenna Configuration	Reference value		UE Category
						Fraction of Maximum Throughput (%)	SNR (dB)	
1	10 MHz	R.11-1 TDD	OP.1 TDD	EVA70	2x2 Low	70	13.1	≥2
2	10 MHz	R.35 TDD	OP.1 TDD	EVA200	2x2 Low	70	20.3	≥2
3	10 MHz	R.35-2 TDD	OP.1 TDD	ETU600	2x2 Low	70	21.1	≥2

Note 1: Void.

Table 8.2.2.3.1-3: Test Parameters for Large Delay CDD (FRC) for CA

Parameter	Unit	Value
Downlink power allocation	ρ_A	dB
	ρ_B	dB
	σ	dB
N_{oc} at antenna port	dBm/15kHz	-98
ACK/NACK feedback mode		PUCCH format 1b with channel selection for Tests in Table 8.2.2.3.1-4; PUCCH format 3 for Tests in Table 8.2.2.3.1-7
PDSCH transmission mode		3

Note 1: $P_B = 1$
Note 2: Void
Note 3: The same PDSCH transmission mode is applied to each component carrier.

Table 8.2.2.3.1-4: Minimum performance Large Delay CDD (FRC) for CA with 2DL CCs

Test number	Bandwidth	Reference Channel	OCNG Pattern	Propagation Condition	Correlation Matrix and Antenna Configuration	Reference value		UE Category
						Fraction of Maximum Throughput (%)	SNR (dB)	
1	2x20 MHz	R.30-1 TDD	OP.1 TDD (Note 1)	EVA70	2x2 Low	70	13.7	≥5
2	20MHz+15MHz	R.30-1 TDD for 20MHz CC	OP.1 TDD (Note 1)	EVA70	2x2 Low	70	13.0	≥5
		R.11-9 TDD for 15MHz CC	OP.1 TDD (Note 1)	EVA70		70	12.9	

Note 1: The OCNG pattern applies for each CC.
Note 2: The applicability of requirements for different CA configurations and bandwidth combination sets is defined in 8.1.2.3.

Table 8.2.2.3.1-5: Single carrier performance for multiple CA configurations

Bandwidth	Reference channel	OCNG pattern	Propagation condition	Correlation matrix and antenna config.	Reference value	
					Fraction of maximum throughput (%)	SNR (dB)

1.4MHz	R.11-5 TDD	OP.1 TDD	EVA70	2x2 Low	70	13.2
3MHz	R.11-6 TDD	OP.1 TDD	EVA70	2x2 Low	70	12.8
5MHz	R.11-7 TDD	OP.1 TDD	EVA70	2x2 Low	70	12.6
10 MHz	R.11-8 TDD	OP.1 TDD	EVA70	2x2 Low	70	12.8
15MHz	R.11-9 TDD	OP.1 TDD	EVA70	2x2 Low	70	12.9
20MHz	R.30-1 TDD	OP. 1 TDD	EVA70	2x2 Low	70	13.0

Table 8.2.2.3.1-6: Void

Table 8.2.2.3.1-7: Minimum performance (FRC) based on single carrier performance for CA with 3 DL CCs

Test num.	CA Band-width combination	Requirement	UE category
1	3x20MHz	As specified in Table 8.2.2.3.1-5 per CC	≥5
2	20MHz+20MHz+15MHz	As specified in Table 8.2.2.3.1-5 per CC	≥5
Note 1: The applicability of requirements for different CA configurations and bandwidth combination sets is defined in 8.1.2.3			

8.2.2.3.1A Soft buffer management test

For CA, the requirements are specified in Table 8.2.2.3.1A-2, with the addition of the parameters in Table 8.2.2.3.1A-1 and the downlink physical channel setup according to Annex C.3.2. The purpose is to verify UE performance with proper instantaneous buffer implementation.

Table 8.2.2.3.1A-1: Test Parameters for soft buffer management test (FRC) for CA

Parameter	Unit	Test 1-2
Downlink power allocation	ρ_A	-3
	ρ_B	-3 (Note 1)
	σ	0
N_{oc} at antenna port	dBm/15kHz	-98
ACK/NACK feedback mode		- (Note 2)
PDSCH transmission mode		3
Note 1: $P_B = 1$		
Note 2: PUCCH format 1b with channel selection is used to feedback ACK/NACK.		
Note 3: For CA test cases, the same PDSCH transmission mode is applied to each component carrier.		

Table 8.2.2.3.1A-2: Minimum performance soft buffer management test (FRC) for CA

Test number	Bandwidth	Reference Channel	OCNG Pattern	Propagation Condition	Correlation Matrix and Antenna Configuration	Reference value		UE Category
						Fraction of Maximum Throughput (%)	SNR (dB)	
1	2x20 MHz	R.30-2 TDD	OP.1 TDD (Note 1)	EVA70	2x2 Low	70	13.2	3
2	2x20 MHz	R.35-1 TDD	OP.1 TDD (Note 1)	EVA5	2x2 Low	70	15.7	4
Note 1: For CA test cases, the OCNG pattern applies for each CC.								
Note 2: The applicability of requirements for different CA configurations and bandwidth combination sets is defined in 8.1.2.3.								

8.2.2.3.1B Enhanced Performance Requirement Type C - 2Tx Antenna Ports

The requirements are specified in Table 8.2.2.3.1B-2, with the addition of the parameters in Table 8.2.2.3.1B-1 and the downlink physical channel setup according to Annex C.3.2. The purpose is to verify the performance of large delay CDD with 2 transmitter antennas.

Table 8.2.2.3.1B-1: Test Parameters for Large Delay CDD (FRC)

Parameter	Unit	Test 1
Downlink power allocation	ρ_A	dB
	ρ_B	dB
	σ	dB
N_{oc} at antenna port	dBm/15kHz	-98
ACK/NACK feedback mode		Bundling
PDSCH transmission mode		3
Note 1: $P_B = 1$		

Table 8.2.2.3.1B-2: Enhanced Performance Requirement Type C for Large Delay CDD (FRC)

Test number	Bandwidth	Reference Channel	OCNG Pattern	Propagation Condition	Correlation Matrix and Antenna Configuration	Reference value		UE Category
						Fraction of Maximum Throughput (%)	SNR (dB)	
1	10 MHz	R.11-1 TDD	OP.1 TDD	EVA70	2x2 Medium	70	17.4	≥ 2

8.2.2.3.1C Enhanced Performance Requirement Type C - 2 Tx Antenna Ports with TM1 interference

The requirements are specified in Table 8.2.2.3.1C-2, with the addition of parameters in Table 8.2.2.3.1C-1 and the downlink physical channel setup according to Annex C.3.2. The purpose is to verify the performance of open-loop spatial multiplexing performance with 2 transmit antennas when the PDSCH transmission in the serving cell is interfered by PDSCH of one dominant interfering cell with transmission mode 1. In Table 8.2.2.3.1C-1, Cell 1 is the serving cell, and Cell 2 is interfering cells. The downlink physical channel setup is according to Annex C.3.2 for each of Cell 1 and Cell 2 respectively.

Table 8.2.2.3.1C-1 Test parameters for Larger Delay CDD (FRC) with TM1 interference

Parameter		Unit	Cell 1	Cell 2
Bandwidth		MHz	10 MHz	
Downlink power allocation	ρ_A	dB	-3	0
	ρ_B		-3 (Note 1)	0
	σ		0	0
Cell-specific reference signals			Antenna ports 0,1	Antenna port 0
Cyclic Prefix			Normal	Normal
Cell ID			0	1
Transmission mode			3	Note 2
N_{oc} at antenna port		dBm/15kHz	-98	N/A
\hat{E}_s/N_{oc} (Note 3)		dB	Reference Value in Table 8.2.2.3.1C-2	12.95
Correlation and antenna configuration			Medium (2x2)	Medium(1x2)
Number of OFDM symbols for PDCCH			2	N/A
Max number of HARQ transmissions			4	N/A
Redundancy version coding sequence			{0,1,2,3}	N/A
Note 1: $P_B = 1$				
Note 2: Downlink physical channel setup in Cell 2 in accordance with Annex C.3.2 applying OCNG pattern OP.5 TDD as defined in Annex A.5.2.5.				
Note 3: Cell 1 is the serving cell. Cell 2 is the interfering cell.				
Note 4: All cells are time-synchronous.				
Note 5: SIB-1 will not be transmitted in Cell2 in this test.				

Table 8.2.2.3.1C-2 Enhanced Performance Requirement Type C, Larger Delay CDD (FRC) with TM1 interference

Test Number	Reference Channel	OCNG Pattern		Propagation Conditions (Note 1)		Reference Value		UE Category
		Cell 1	Cell 2	Cell 1	Cell 2	Fraction of Maximum Throughput (%)	SNR (dB) (Note 2)	
1	R.11-10 TDD	OP.1 TDD	OP.5 TDD	EVA70	EVA70	70	19.6	≥ 2
Note 1: The propagation conditions for Cell 1 and Cell 2 are statistically independent.								
Note 2: SNR corresponds to \hat{E}_s/N_{oc} of Cell 1.								

8.2.2.3.2 Minimum Requirement 4 Tx Antenna Port

The requirements are specified in Table 8.2.2.3.2-2, with the addition of the parameters in Table 8.2.2.3.2-1 and the downlink physical channel setup according to Annex C.3.2. The purpose is to verify the performance of large delay CDD with 4 transmitter antennas.

Table 8.2.2.3.2-1: Test Parameters for Large Delay CDD (FRC)

Parameter		Unit	Test 1
Downlink power allocation	ρ_A	dB	-6
	ρ_B	dB	-6 (Note 1)
	σ	dB	3
N_{oc} at antenna port		dBm/15kHz	-98
ACK/NACK feedback mode			Bundling
PDSCH transmission mode			3
Note 1: $P_B = 1$.			

Table 8.2.2.3.2-2: Minimum performance Large Delay CDD (FRC)

Test number	Bandwidth	Reference Channel	OCNG Pattern	Propagation Condition	Correlation Matrix and Antenna Configuration	Reference value		UE Category
						Fraction of Maximum Throughput (%)	SNR (dB)	
1	10 MHz	R.14 TDD	OP.1 TDD	EVA70	4x2 Low	70	14.2	≥ 2

8.2.2.3.3 Minimum Requirement 2Tx antenna port (demodulation subframe overlaps with aggressor cell ABS)

The requirements for non-MBSFN ABS are specified in Table 8.2.2.3.3-2, with the addition of parameters in Table 8.2.2.3.3-1 and the downlink physical channel setup according to Annex C.3.2 and Annex C.3.3.

The requirements for MBSFN ABS are specified in Table 8.2.2.3.3-4, with the addition of parameters in Table 8.2.2.3.3-3 and the downlink physical channel setup according to Annex C.3.2 and Annex C.3.3.

The purpose is to verify the performance of large delay CDD with 2 transmitter antennas if the PDSCH transmission in the serving cell takes place in subframes that overlap with ABS [9] of the aggressor cell. In Tables 8.2.2.3.3-1 and 8.2.2.3.3-3, Cell 1 is the serving cell, and Cell 2 is the aggressor cell. The downlink physical channel setup for Cell 1 is according to Annex C.3.2 and for Cell 2 is according to Annex C.3.3, respectively.

Table 8.2.2.3.3-1: Test Parameters for Large Delay CDD (FRC) – Non-MBSFN ABS

Parameter	Unit	Cell 1	Cell 2
Uplink downlink configuration		1	1
Special subframe configuration		4	4
Downlink power allocation	ρ_A	dB	-3
	ρ_B	dB	-3 (Note 1)
	σ	dB	0
N_{oc} at antenna port	N_{oc1}	dBm/15kHz	-102 (Note 2)
	N_{oc2}	dBm/15kHz	-98 (Note 3)
	N_{oc3}	dBm/15kHz	-94.8 (Note 4)
\widehat{E}_s/N_{oc2}	dB	Reference Value in Table 8.2.2.3.3-2	6
$BW_{Channel}$	MHz	10	10
Subframe Configuration		Non-MBSFN	Non-MBSFN
Cell Id		0	1
Time Offset between Cells	μs	2.5 (synchronous cells)	
ABS pattern (Note 5)		N/A	0000010001, 0000000001
RLM/RRM Measurement Subframe Pattern (Note 6)		0000000001, 0000000001	N/A
CSI Subframe Sets (Note 7)	$C_{CSI,0}$	0000010001, 0000000001	N/A
	$C_{CSI,1}$	1100101000 1100111000	N/A
Number of control OFDM symbols		2	2
ACK/NACK feedback mode		Multiplexing	N/A
PDSCH transmission mode		3	N/A
Cyclic prefix		Normal	Normal
<p>Note 1: $P_B = 1$.</p> <p>Note 2: This noise is applied in OFDM symbols #1, #2, #3, #5, #6, #8, #9, #10, #12, #13 of a subframe overlapping with the aggressor ABS.</p> <p>Note 3: This noise is applied in OFDM symbols #0, #4, #7, #11 of a subframe overlapping with the aggressor ABS.</p> <p>Note 4: This noise is applied in all OFDM symbols of a subframe overlapping with aggressor non-ABS.</p> <p>Note 5: ABS pattern as defined in [9].</p> <p>Note 6: Time-domain measurement resource restriction pattern for PCell measurements as defined in [7].</p> <p>Note 7: As configured according to the time-domain measurement resource restriction pattern for CSI measurements defined in [7].</p> <p>Note 8: Cell 1 is the serving cell. Cell 2 is the aggressor cell. The number of the CRS ports in Cell1 and Cell2 is the same.</p> <p>Note 9: SIB-1 will not be transmitted in Cell2 in this test.</p>			

Table 8.2.2.3.3-2: Minimum Performance Large Delay CDD (FRC) – Non-MBSFN ABS

Test Number	Reference Channel	OCNG Pattern		Propagation Conditions (Note 1)		Correlation Matrix and Antenna Configuration	Reference Value		UE Category
		Cell 1	Cell 2	Cell 1	Cell 2		Fraction of Maximum Throughput (%) Note 5	SNR (dB) (Note 2)	
1	R.11 TDD Note 4	OP.1 TDD	OP.1 TDD	EVA 5	EVA 5	2x2 Low	70	14.0	≥2
<p>Note 1: The propagation conditions for Cell 1 and Cell2 are statistically independent.</p> <p>Note 2: SNR corresponds to \hat{E}_s / N_{oc2} of cell 1.</p> <p>Note 3: The correlation matrix and antenna configuration apply for Cell 1 and Cell 2.</p> <p>Note 4: Cell 1 Reference channel is modified: PDSCH other than SIB1/paging and its associated PDCCH/PCFICH are transmitted in the serving cell subframe when the subframe is overlapped with the ABS subframe of aggressor cell and the subframe is available in the definition of the reference channel.</p> <p>Note 5: The maximum Throughput is calculated from the total Payload in 2 subframes, averaged over 20ms.</p>									

Table 8.2.2.3.3-3: Test Parameters for Large Delay CDD (FRC) – MBSFN ABS

Parameter		Unit	Cell 1	Cell 2
Uplink downlink configuration			1	1
Special subframe configuration			4	4
Downlink power allocation	ρ_A	dB	-3	-3
	ρ_B	dB	-3 (Note 1)	-3 (Note 1)
	σ	dB	0	N/A
N_{oc} at antenna port	N_{oc1}	dBm/15kHz	-102 (Note 2)	N/A
	N_{oc2}	dBm/15kHz	-98 (Note 3)	N/A
	N_{oc3}	dBm/15kHz	-94.8 (Note 4)	N/A
\widehat{E}_s / N_{oc2}		dB	Reference Value in Table 8.2.2.3.3-4	6
BW_{Channel}		MHz	10	10
Subframe Configuration			Non-MBSFN	MBSFN
Cell Id			0	126
Time Offset between Cells		μs	2.5 (synchronous cells)	
ABS pattern (Note 5)			N/A	000000001 000000001
RLM/RRM Measurement Subframe Pattern (Note 6)			000000001 000000001	N/A
CSI Subframe Sets (Note 7)	$C_{\text{CSI},0}$		000000001 000000001	N/A
	$C_{\text{CSI},1}$		1100111000 1100111000	N/A
MBSFN Subframe Allocation (Note 10)			N/A	000010
Number of control OFDM symbols			2	2
ACK/NACK feedback mode			Multiplexing	N/A
PDSCH transmission mode			3	N/A
Cyclic prefix			Normal	Normal
<p>Note 1: $P_B = 1$.</p> <p>Note 2: This noise is applied in OFDM symbols #1, #2, #3, #4, #5, #6, #7, #8, #9, #10, #11, #12, #13 of a subframe overlapping with the aggressor ABS.</p> <p>Note 3: This noise is applied in OFDM symbol #0 of a subframe overlapping with the aggressor ABS.</p> <p>Note 4: This noise is applied in all OFDM symbols of a subframe overlapping with aggressor non-ABS.</p> <p>Note 5: ABS pattern as defined in [9]. The 10th and 20th subframes indicated by ABS pattern are MBSFN ABS subframes.</p> <p>Note 6: Time-domain measurement resource restriction pattern for PCell measurements as defined in [7]</p> <p>Note 7: As configured according to the time-domain measurement resource restriction pattern for CSI measurements defined in [7].</p> <p>Note 8: Cell 1 is the serving cell. Cell 2 is the aggressor cell. The number of the CRS ports in Cell1 and Cell2 is the same.</p> <p>Note 9: SIB-1 will not be transmitted in Cell2 in this test.</p> <p>Note 10: MBSFN Subframe Allocation as defined in [7], one frame with 6 bits is chosen for MBSFN subframe allocation.</p>				

Table 8.2.2.3.3-4: Minimum Performance Large Delay CDD (FRC) – MBSFN ABS

Test Number	Reference Channel	OCNG Pattern		Propagation Conditions (Note 1)		Correlation Matrix and Antenna Configuration	Reference Value		UE Category
		Cell 1	Cell 2	Cell 1	Cell 2		Fraction of Maximum Throughput (%) Note 5	SNR (dB) (Note 2)	
1	R.11 TDD Note 4	OP.1 TDD	OP.1 TDD	EVA 5	EVA 5	2x2 Low	70	12.2	≥2
<p>Note 1: The propagation conditions for Cell 1 and Cell2 are statistically independent.</p> <p>Note 2: SNR corresponds to \hat{E}_s / N_{oc2} of cell 1.</p> <p>Note 3: The correlation matrix and antenna configuration apply for Cell 1 and Cell 2.</p> <p>Note 4: Cell 1 Reference channel is modified: PDSCH other than SIB1/paging and its associated PDCCH/PCFICH are transmitted in the serving cell subframe when the subframe is overlapped with the ABS subframe of aggressor cell and the subframe is available in the definition of the reference channel.</p> <p>Note 5: The maximum Throughput is calculated from the total Payload in 2 subframes, averaged over 20ms.</p>									

8.2.2.3.4 Minimum Requirement 2 Tx Antenna Port (demodulation subframe overlaps with aggressor cell ABS and CRS assistance information are configured)

The requirements for non-MBSFN ABS are specified in Table 8.2.2.3.4-2, with the addition of parameters in Table 8.2.2.3.4-1. The purpose is to verify the performance of large delay CDD with 2 transmitter antennas if the PDSCH transmission in the serving cell takes place in subframes that overlap with ABS [9] of the aggressor cell with CRS assistance information. In Table 8.2.2.3.4-1, Cell 1 is the serving cell, and Cell 2 and Cell3 are the aggressor cells. The downlink physical channel setup for Cell 1 is according to Annex C.3.2 and for Cell 2 and Cell 3 is according to Annex C.3.3, respectively. The CRS assistance information [7] includes Cell 2 and Cell 3.

Table 8.2.2.3.4-1: Test Parameters for Large Delay CDD (FRC) – Non-MBSFN ABS

Parameter		Unit	Cell 1	Cell 2	Cell 3
Uplink downlink configuration			1	1	1
Special subframe configuration			4	4	4
Downlink power allocation	ρ_A	dB	-3	-3	-3
	ρ_B	dB	-3 (Note 1)	-3 (Note 1)	-3 (Note 1)
	σ	dB	0	N/A	N/A
N_{oc} at antenna port	N_{oc1}	dBm/15kHz	-98 (Note 2)	N/A	N/A
	N_{oc2}	dBm/15kHz	-98 (Note 3)	N/A	N/A
	N_{oc3}	dBm/15kHz	-93 (Note 4)	N/A	N/A
\hat{E}_s / N_{oc2}		dB	Reference Value in Table 8.2.2.3.4-2	Reference Value in Table 8.2.2.3.4-2	Reference Value in Table 8.2.2.3.4-2
BW _{Channel}		MHz	10	10	10
Subframe Configuration			Non-MBSFN	Non-MBSFN	Non-MBSFN
Time Offset between Cells		μs	N/A	3	-1
Frequency shift between Cells		Hz	N/A	300	-100
Cell Id			0	1	126
ABS pattern (Note 5)			N/A	0000000001 0000000001	0000000001 0000000001
RLM/RRM Measurement Subframe Pattern (Note 6)			0000000001 0000000001	N/A	N/A
CSI Subframe Sets (Note7)	C _{CSI,0}		0000000001 0000000001	N/A	N/A
	C _{CSI,1}		1100111000 1100111000	N/A	N/A
Number of control OFDM symbols			2	Note 8	Note 8
ACK/NACK feedback mode			Multiplexing	N/A	N/A
PDSCH transmission mode			3	Note 9	Note 9
Cyclic prefix			Normal	Normal	Normal
<p>Note 1: $P_B = 1$.</p> <p>Note 2: This noise is applied in OFDM symbols #1, #2, #3, #5, #6, #8, #9, #10, #12, #13 of a subframe overlapping with the aggressor ABS.</p> <p>Note 3: This noise is applied in OFDM symbols #0, #4, #7, #11 of a subframe overlapping with the aggressor ABS.</p> <p>Note 4: This noise is applied in all OFDM symbols of a subframe overlapping with aggressor non-ABS</p> <p>Note 5: ABS pattern as defined in [9].</p> <p>Note 6: Time-domain measurement resource restriction pattern for PCell measurements as defined in [7]</p> <p>Note 7: As configured according to the time-domain measurement resource restriction pattern for CSI measurements defined in [7].</p> <p>Note 8: The number of control OFDM symbols is not available for ABS and is 2 for the subframe indicated by "0" of ABS pattern.</p> <p>Note 9: Downlink physical channel setup in Cell 2 and Cell 3 in accordance with Annex C.3.3 applying OCN pattern as defined in Annex A.5.</p> <p>Note 10: The number of the CRS ports in Cell1, Cell2 and Cell 3 is the same.</p> <p>Note 11: SIB-1 will not be transmitted in Cell2 and Cell 3 in this test.</p>					

Table 8.2.2.3.4-2: Minimum Performance Large Delay CDD (FRC) – Non-MBSFN ABS

Test Number	Reference Channel	\hat{E}_s/N_{oc2}		OCNG Pattern			Propagation Conditions (Note1)			Correlation Matrix and Antenna Configuration (Note 2)	Reference Value		UE Category
		Cell 2	Cell 3	Cell 1	Cell 2	Cell 3	Cell 1	Cell 2	Cell 3		Fraction of Maximum Throughput (%) Note 5	SNR (dB) (Note 3)	
1	R.11 TDD Note 4	9	7	OP.1 TDD	OP.1 TDD	OP.1 TDD	EVA5	EVA5	EVA5	2x2 Low	70	14.2	≥ 2
2	R.35 TDD Note 4	9	1	OP.1 TDD	OP.1 TDD	OP.1 TDD	EVA5	EVA5	EVA5	2x2 Low	70	22.7	≥ 2

Note 1: The propagation conditions for Cell 1, Cell 2 and Cell 3 are statistically independent.

Note 2: The correlation matrix and antenna configuration apply for Cell 1, Cell 2 and Cell 3.

Note 3: SNR corresponds to \hat{E}_s/N_{oc2} of cell 1.

Note 4: Cell 1 Reference channel is modified: PDSCH other than SIB1/paging and its associated PDCCH/PCFICH are transmitted in the serving cell subframe when the subframe is overlapped with the ABS subframe of aggressor cell and the subframe is available in the definition of the reference channel.

Note 5: The maximum Throughput is calculated from the total Payload in 2 subframes, averaged over 20ms.

8.2.2.4 Closed-loop spatial multiplexing performance

8.2.2.4.1 Minimum Requirement Single-Layer Spatial Multiplexing 2 Tx Antenna Port

The requirements are specified in Table 8.2.2.4.1-2, with the addition of the parameters in Table 8.2.2.4.1-1 and the downlink physical channel setup according to Annex C.3.2. The purpose of these tests is to verify the closed loop rank-one performance with wideband and frequency selective precoding.

Table 8.2.2.4.1-1: Test Parameters for Single-Layer Spatial Multiplexing (FRC)

Parameter	Unit	Test 1	Test 2
Downlink power allocation	ρ_A	dB	-3
	ρ_B	dB	-3 (Note 1)
	σ	dB	0
N_{oc} at antenna port	dBm/15kHz	-98	-98
Precoding granularity	PRB	6	50
PMI delay (Note 2)	ms	10 or 11	10 or 11
Reporting interval	ms	1 or 4 (Note 3)	1 or 4 (Note 3)
Reporting mode		PUSCH 1-2	PUSCH 3-1
CodeBookSubsetRestriction bitmap		001111	001111
ACK/NACK feedback mode		Multiplexing	Multiplexing
PDSCH transmission mode		4	4
Note 1: $P_B = 1$.			
Note 2: If the UE reports in an available uplink reporting instance at subframe SF#n based on PMI estimation at a downlink SF not later than SF#(n-4), this reported PMI cannot be applied at the eNB downlink before SF#(n+4).			
Note 3: For Uplink - downlink configuration 1 the reporting interval will alternate between 1ms and 4ms.			

Table 8.2.2.4.1-2: Minimum performance Single-Layer Spatial Multiplexing (FRC)

Test number	Bandwidth	Reference Channel	OCNG Pattern	Propagation Condition	Correlation Matrix and Antenna Configuration	Reference value		UE Category
						Fraction of Maximum Throughput (%)	SNR (dB)	
1	10 MHz	R.10 TDD	OP.1 TDD	EVA5	2x2 Low	70	-3.1	≥1
2	10 MHz	R.10 TDD	OP.1 TDD	EPA5	2x2 High	70	-2.8	≥1

8.2.2.4.1A Minimum Requirement Single-Layer Spatial Multiplexing 4 Tx Antenna Port

The requirements are specified in Table 8.2.2.4.1A-2, with the addition of the parameters in Table 8.2.2.4.1A-1 and the downlink physical channel setup according to Annex C.3.2. The purpose of these tests is to verify the closed loop rank-one performance with wideband and frequency selective precoding.

Table 8.2.2.4.1A-1: Test Parameters for Single-Layer Spatial Multiplexing (FRC)

Parameter	Unit	Test 1
Downlink power allocation	ρ_A	dB
	ρ_B	dB
	σ	dB
N_{oc} at antenna port	dBm/15kHz	-98
Precoding granularity	PRB	6
PMI delay (Note 2)	ms	10 or 11
Reporting interval	ms	1 or 4 (Note 3)
Reporting mode		PUSCH 1-2
CodeBookSubsetRestriction bitmap		0000000000000000 0000000000000000 0000000000000011 11111111111111
ACK/NACK feedback mode		Multiplexing
PDSCH transmission mode		4
Note 1: $P_B = 1$. Note 2: If the UE reports in an available uplink reporting instance at subframe SF#n based on PMI estimation at a downlink SF not later than SF#(n-4), this reported PMI cannot be applied at the eNB downlink before SF#(n+4). Note 3: For Uplink - downlink configuration 1 the reporting interval will alternate between 1ms and 4ms.		

Table 8.2.2.4.1A-2: Minimum performance Single-Layer Spatial Multiplexing (FRC)

Test number	Bandwidth	Reference Channel	OCNG Pattern	Propagation Condition	Correlation Matrix and Antenna Configuration	Reference value		UE Category
						Fraction of Maximum Throughput (%)	SNR (dB)	
1	10 MHz	R.13 TDD	OP.1 TDD	EVA5	4x2 Low	70	-3.5	≥1

8.2.2.4.1B Enhanced Performance Requirement Type A – Single-Layer Spatial Multiplexing 2 Tx Antenna Port with TM4 interference model

The requirements are specified in Table 8.2.2.4.1B-2, with the addition of the parameters in Table 8.2.2.4.1B-1 and the downlink physical channel setup according to Annex C.3.2. The purpose of these tests is to verify the closed loop rank-

one performance with wideband precoding with two transmit antennas when the PDSCH transmission in the serving cell is interfered by PDSCH of two dominant interfering cells applying transmission mode 4 interference model defined in clause B.5.3. In Table 8.2.2.4.1B-1, Cell 1 is the serving cell, and Cell 2, 3 are interfering cells. The downlink physical channel setup is according to Annex C.3.2 for each of Cell 1, Cell 2 and Cell 3, respectively.

Table 8.2.2.4.1B-1: Test Parameters for Single-Layer Spatial Multiplexing (FRC) with TM4 interference model

Parameter		Unit	Cell 1	Cell 2	Cell 3
Downlink power allocation	ρ_A	dB	-3	-3	-3
	ρ_B	dB	-3 (Note 1)	-3	-3
	σ	dB	0	0	0
Cell-specific reference signals			Antenna ports 0,1	Antenna ports 0,1	Antenna ports 0,1
N_{oc} at antenna port		dBm/15kHz	-98	N/A	N/A
DIP (Note 2)		dB	N/A	-1.73	-8.66
BW_{Channel}		MHz	10	10	10
Cyclic Prefix			Normal	Normal	Normal
Cell Id			0	1	2
Number of control OFDM symbols			2	2	2
PDSCH transmission mode			6	N/A	N/A
Interference model			N/A	As specified in clause B.5.3	As specified in clause B.5.3
Probability of occurrence of transmission rank in interfering cells	Rank 1	%	N/A	80	80
	Rank 2	%	N/A	20	20
Precoding granularity		PRB	50	6	6
PMI delay (Note 4)		ms	10 or 11	N/A	N/A
Reporting interval		ms	5	N/A	N/A
Reporting mode			PUCCH 1-1	N/A	N/A
CodeBookSubsetRestriction bitmap			1111	N/A	N/A
ACK/NACK feedback mode			Multiplexing	N/A	N/A
Physical channel for CQI reporting			PUSCH(Note 6)	N/A	N/A
cqi-pmi-ConfigurationIndex			4	N/A	N/A
<p>Note 1: $P_B = 1$</p> <p>Note 2: The respective received power spectral density of each interfering cell relative to N_{oc} is defined by its associated DIP value as specified in clause B.5.1.</p> <p>Note 3: Cell 1 is the serving cell. Cell 2, 3 are the interfering cells.</p> <p>Note 4: If the UE reports in an available uplink reporting instance at subframe SF#n based on PMI estimation at a downlink SF not later than SF#(n-4), this reported PMI cannot be applied at the eNB downlink before SF#(n+4).</p> <p>Note 5: All cells are time-synchronous.</p> <p>Note 6: To avoid collisions between CQI reports and HARQ-ACK it is necessary to report both on PUSCH instead of PUCCH. PDCCH DCI format 0 shall be transmitted in downlink SF#4 and #9 to allow periodic CQI to multiplex with the HARQ-ACK on PUSCH in uplink subframe SF#8 and #3.</p>					

Table 8.2.2.4.1B-2: Enhanced Performance Requirement Type A, Single-Layer Spatial Multiplexing (FRC) with TM4 interference model

Test Number	Reference Channel	OCNG Pattern			Propagation Conditions			Correlation Matrix and Antenna Configuration (Note 3)	Reference Value		UE Category
		Cell 1	Cell 2	Cell 3	Cell 1	Cell 2	Cell 3		Fraction of Maximum Throughput (%)	SINR (dB) (Note 2)	
1	R.47 TDD	OP. 1 TD D	N/A	N/A	EV A5	EV A5	EV A5	2x2 Low	70	1.1	≥1

Note 1: The propagation conditions for Cell 1, Cell 2 and Cell 3 are statistically independent.

Note 2: SINR corresponds to \hat{E}_s / N_{oc} of Cell 1 as defined in clause 8.1.1.

Note 3: Correlation matrix and antenna configuration parameters apply for each of Cell 1, Cell 2 and Cell 3.

8.2.2.4.1C Minimum Requirement Single-Layer Spatial Multiplexing 2 Tx Antenna Ports (demodulation subframe overlaps with aggressor cell ABS and CRS assistance information are configured)

The requirements are specified in Table 8.2.2.4.1C-2, with the addition of parameters in Table 8.2.2.4.1C-1. The purpose is to verify the closed loop rank-one performance with wideband precoding if the PDSCH transmission in the serving cell takes place in subframes that overlap with ABS [9] of the aggressor cell with CRS assistance information. In Table 8.2.2.4.1C-1, Cell 1 is the serving cell, and Cell 2 and Cell 3 are the aggressor cells. The downlink physical channel setup for Cell 1 is according to Annex C.3.2 and for Cell 2 and Cell 3 is according to Annex C.3.3, respectively. The CRS assistance information [7] includes Cell 2 and Cell 3.

Table 8.2.2.4.1C-1: Test Parameters for Single-Layer Spatial Multiplexing (FRC) – Non-MBSFN ABS

Parameter		Unit	Cell 1	Cell 2	Cell 3
Uplink downlink configuration			1	1	1
Special subframe configuration			4	4	4
Downlink power allocation	ρ_A	dB	-3	-3	-3
	ρ_B	dB	-3 (Note 1)	-3 (Note 1)	-3 (Note 1)
	σ	dB	0	N/A	N/A
N_{oc} at antenna port	N_{oc1}	dBm/15kHz	-98 (Note 2)	N/A	N/A
	N_{oc2}	dBm/15kHz	-98 (Note 3)	N/A	N/A
	N_{oc3}	dBm/15kHz	-93 (Note 4)	N/A	N/A
\hat{E}_s / N_{oc2}		dB	Reference Value in Table 8.2.2.4.1C-2	12	10
$BW_{Channel}$		MHz	10	10	10
Subframe Configuration			Non-MBSFN	Non-MBSFN	Non-MBSFN
Time Offset between Cells		μ s	N/A	3	-1
Frequency shift between Cells		Hz	N/A	300	-100
Cell Id			0	126	1
ABS pattern (Note 5)			N/A	0000000001 0000000001	0000000001 0000000001
RLM/RRM Measurement Subframe Pattern (Note 6)			0000000001 0000000001	N/A	N/A
CSI Subframe Sets (Note7)	$C_{CSI,0}$		0000000001 0000000001	N/A	N/A
	$C_{CSI,1}$		1100111000 1100111000	N/A	N/A
Number of control OFDM symbols			2	Note 8	Note 8
ACK/NACK feedback mode			Multiplexing	N/A	N/A
PDSCH transmission mode			6	Note 9	Note 9
Precoding granularity		PRB	50	N/A	N/A
PMI delay (Note 10)		ms	10 or 11	N/A	N/A
Reporting interval		ms	1 or 4 (Note 11)	N/A	N/A
Reporting mode			PUSCH 3-1	N/A	N/A
CodeBookSubsetRestriction bitmap			1111	N/A	N/A
Cyclic prefix			Normal	Normal	Normal
<p>Note 1: $P_B = 1$.</p> <p>Note 2: This noise is applied in OFDM symbols #1, #2, #3, #5, #6, #8, #9, #10, #12, #13 of a subframe overlapping with the aggressor ABS.</p> <p>Note 3: This noise is applied in OFDM symbols #0, #4, #7, #11 of a subframe overlapping with the aggressor ABS.</p> <p>Note 4: This noise is applied in all OFDM symbols of a subframe overlapping with aggressor non-ABS</p> <p>Note 5: ABS pattern as defined in [9].</p> <p>Note 6: Time-domain measurement resource restriction pattern for PCell measurements as defined in [7]</p> <p>Note 7: As configured according to the time-domain measurement resource restriction pattern for CSI measurements defined in [7].</p> <p>Note 8: The number of control OFDM symbols is not available for ABS and is 2 for the subframe indicated by "0" of ABS pattern.</p> <p>Note 9: Downlink physical channel setup in Cell 2 and Cell 3 in accordance with Annex C.3.3 applying OCNG pattern as defined in Annex A.5.</p> <p>Note 10: If the UE reports in an available uplink reporting instance at subframe SF#n based on PMI estimation at a downlink SF not later than SF#(n-4), this reported PMI cannot be applied at the eNB downlink before SF#(n+4).</p> <p>Note 11: For Uplink - downlink configuration 1 the reporting interval will alternate between 1ms and 4ms.</p> <p>Note 12: The number of the CRS ports in Cell 1, Cell 2 and Cell 3 is the same.</p> <p>Note 13: SIB-1 will not be transmitted in Cell 2 and Cell 3 in this test.</p>					

Table 8.2.2.4.1C-2: Minimum Performance Single-Layer Spatial Multiplexing (FRC)– Non-MBSFN ABS

Test Number	Reference Channel	OCNG Pattern			Propagation Conditions (Note1)			Correlation Matrix and Antenna Configuration (Note 2)	Reference Value		UE Category
		Cell 1	Cell 2	Cell 3	Cell 1	Cell 2	Cell 3		Fraction of Maximum Throughput (%) Note 5	SNR (dB) (Note 3)	
1	R.11 TDD Note 4	OP.1 TDD	OP.1 FDD	OP.1 TDD	EPA5	EPA5	EPA5	2x2 High	70	6.4	≥2
<p>Note 1: The propagation conditions for Cell 1, Cell 2 and Cell 3 are statistically independent.</p> <p>Note 2: The correlation matrix and antenna configuration apply for Cell 1, Cell 2 and Cell 3.</p> <p>Note 3: SNR corresponds to \hat{E}_s / N_{oc2} of cell 1.</p> <p>Note 4: Cell 1 Reference channel is modified: PDSCH other than SIB1/paging and its associated PDCCH/PCFICH are transmitted in the serving cell subframe when the subframe is overlapped with the ABS subframe of aggressor cell and the subframe is available in the definition of the reference channel.</p> <p>Note 5: The maximum Throughput is calculated from the total Payload in 2 subframes, averaged over 20ms.</p>											

8.2.2.4.1D Enhanced Performance Requirement Type B - Single-layer Spatial Multiplexing 2 Tx Antenna Port with TM4 interference model

The requirements are specified in Table 8.2.2.4.1D-2, with the addition of the parameters in Table 8.2.2.4.1D-1 and the downlink physical channel setup according to Annex C.3.2. The purpose of these tests is to verify the closed loop rank-one performance with wideband precoding with two transmit antennas when the PDSCH transmission in the serving cell is interfered by PDSCH of two interfering cells applying transmission mode 4 interference model defined in clause B.6.3. In Table 8.2.2.4.1D-1, Cell 1 is the serving cell, and Cell 2, 3 are interfering cells. The downlink physical channel setup is according to Annex C.3.2 for each of Cell 1, Cell 2 and Cell 3, respectively.

Table 8.2.2.4.1D-1: Test Parameters for Single-layer Spatial Multiplexing (FRC) with TM4 interference model

Parameter		Unit	Cell 1	Cell 2		Cell 3	
Uplink downlink Configuration			1	1		1	
Special subframe configuration			4	4		4	
Downlink power allocation	ρ_A	dB	-3	-3		-3	
	ρ_B	dB	-3 (NOTE 1)	-3		-3	
	σ	dB	0	0		0	
Cell-specific reference signals			Antenna ports 0,1	Antenna ports 0,1		Antenna ports 0,1	
N_{oc} at antenna port		dBm/15 kHz	-98				
Test number (NOTE 4)				Test 1	Test 2	Test 1	Test 2
\hat{E}_s/N_{oc}		dB	N/A	13.91	3.28	3.34	0.74
Cell Id				6	1	1	6
CFI indicated in PCFICH in normal subframes				3	Random from set {1,2,3}	3	Random from set {1,2,3}
CFI indicated in PCFICH in special subframes				3	Random from set {1,2}	3	Random from set {1,2}
BW _{Channel}		MHz	10	10		10	
Cyclic Prefix			Normal	Normal		Normal	
Number of control OFDM symbols in normal subframes			3	3		3	
Number of control OFDM symbols in special subframes			2	2		2	
PDSCH transmission mode			4	4		4	
Interference model			N/A	As specified in clause B.6.3		As specified in clause B.6.3	
Precoding			Random wideband precoding per TTI	As specified in clause B.6.3		As specified in clause B.6.3	
Time offset to cell 1		us	N/A	2		3	
Frequency offset to cell 1		Hz	N/A	200		300	
MBSFN			Not configured	Not configured		Not configured	
NeighCellsInfo-r12 (NOTE 3)	p-aList-r12		N/A	{dB-6, dB-3, dB0}		{dB-6, dB-3, dB0}	
	transmissionModeList-r12		N/A	{2,3,4,8,9}		{2,3,4,8,9}	
NOTE 1: $P_b = 1$							
NOTE 2: Cell 1 is the serving cell. Cell 2, 3 are the interfering cells.							
NOTE 3: NeighCellsInfo-r12 is described in subclause 6.3.2 of [7].							
NOTE 4: Test 1 and Test 2 are defined in Table 8.2.2.4.1D-2.							

Table 8.2.2.4.1D-2: Minimum Performance for Enhanced Performance Requirement Type B, Single-layer Spatial Multiplexing (FRC) with TM4 interference model

Test Num	Reference Channel	OCNG Pattern			Propagation Conditions			Correlation Matrix and Antenna Configuration (NOTE 3)	Reference Value		UE Category
		Cell 1	Cell 2	Cell 3	Cell 1	Cell 2	Cell 3		Fraction of Maximum Throughput (%)	SNR (dB) (NOTE 2)	
1	R.11-12 TDD	OP.1 TDD	N/A	N/A	EVA 5	EVA 5	EVA 5	2x2 Low	85	16.1	≥1
2	R.11-11 TDD	OP.1 TDD	N/A	N/A	EPA 5	EPA 5	EPA 5	2x2 Low	85	9.5	≥1

NOTE 1: The propagation conditions for Cell 1, Cell 2 and Cell 3 are statistically independent.

NOTE 2: SNR corresponds to \hat{E}_s/N_{oc} of Cell 1 as defined in clause 8.1.1.

NOTE 3: Correlation matrix and antenna configuration parameters apply for each of Cell 1, Cell 2 and Cell 3.

8.2.2.4.2 Minimum Requirement Multi-Layer Spatial Multiplexing 2 Tx Antenna Port

The requirements are specified in Table 8.2.2.4.2-2, with the addition of the parameters in Table 8.2.2.4.2-1 and the downlink physical channel setup according to Annex C.3.2. The purpose of these tests is to verify the closed loop rank-two performance with wideband and frequency selective precoding.

Table 8.2.2.4.2-1: Test Parameters for Multi-Layer Spatial Multiplexing (FRC)

Parameter	Unit	Test 1-2	Test 3
Downlink power allocation	ρ_A	dB	-3
	ρ_B	dB	-3 (Note 1)
	σ	dB	0
N_{oc} at antenna port	dBm/15kHz	-98	-98
Precoding granularity	PRB	50	8
PMI delay (Note 2)	ms	10 or 11	10 or 11
Reporting interval	ms	1 or 4 (Note 3)	1 or 4 (Note 3)
Reporting mode		PUSCH 3-1	PUSCH 1-2
ACK/NACK feedback mode		Bundling	Bundling
CodeBookSubsetRestriction bitmap		110000	110000
PDSCH transmission mode		4	4
Number of OFDM symbols for PDCCH per component carrier	OFDM symbol	2	1

Note 1: $P_B = 1$.

Note 2: If the UE reports in an available uplink reporting instance at subframe SF#n based on PMI estimation at a downlink SF not later than SF#(n-4), this reported PMI cannot be applied at the eNB downlink before SF#(n+4).

Note 3: For Uplink - downlink configuration 1 the reporting interval will alternate between 1ms and 4ms.

Table 8.2.2.4.2-2: Minimum performance Multi-Layer Spatial Multiplexing (FRC)

Test number	Bandwidth	Reference Channel	OCNG Pattern	Propagation Condition	Correlation Matrix and Antenna Configuration	Reference value		UE Category	UE DL category
						Fraction of Maximum Throughput (%)	SNR (dB)		
1	10 MHz	R.35 TDD	OP.1 TDD	EPA5	2x2 Low	70	19.5	≥2	≥6
2	10 MHz	R.11-1 TDD	OP.1 TDD	ETU70	2x2 Low	70	13.9	≥2	≥6
3	20 MHz 256QAM	R. 65 TDD	OP.1 TDD	EVA5	2x2 Low	70	24.9	11-12	≥11

8.2.2.4.2A Enhanced Performance Requirement Type C Multi-Layer Spatial Multiplexing 2 Tx Antenna Port

The requirements are specified in Table 8.2.2.4.2A-2, with the addition of the parameters in Table 8.2.2.4.2A-1 and the downlink physical channel setup according to Annex C.3.2. The purpose of these tests is to verify the closed loop rank-two performance with wideband precoding.

Table 8.2.2.4.2A-1: Test Parameters for Multi-Layer Spatial Multiplexing (FRC)

Parameter	Unit	Test 1	
Downlink power allocation	ρ_A	dB	-3
	ρ_B	dB	-3 (Note 1)
	σ	dB	0
N_{oc} at antenna port	dBm/15kHz	-98	
Precoding granularity	PRB	50	
PMI delay (Note 2)	ms	10 or 11	
Reporting interval	ms	1 or 4 (Note 3)	
Reporting mode		PUSCH 3-1	
ACK/NACK feedback mode		Bundling	
CodeBookSubsetRestriction bitmap		110000	
PDSCH transmission mode		4	
Note 1: $P_B = 1$.			
Note 2: If the UE reports in an available uplink reporting instance at subframe SF#n based on PMI estimation at a downlink SF not later than SF#(n-4), this reported PMI cannot be applied at the eNB downlink before SF#(n+4).			
Note 3: For Uplink - downlink configuration 1 the reporting interval will alternate between 1ms and 4ms.			

Table 8.2.2.4.2A-2: Enhanced Performance Requirement Type C for Multi-Layer Spatial Multiplexing (FRC)

Test number	Bandwidth	Reference Channel	OCNG Pattern	Propagation Condition	Correlation Matrix and Antenna Configuration	Reference value		UE Category
						Fraction of Maximum Throughput (%)	SNR (dB)	
1	10 MHz	R.11-1 TDD	OP.1 TDD	ETU70	2x2 Medium	70	17.8	≥ 2

8.2.2.4.3 Minimum Requirement Multi-Layer Spatial Multiplexing 4 Tx Antenna Port

For single carrier, the requirements are specified in Table 8.2.2.4.3-2, with the addition of the parameters in Table 8.2.2.4.3-1 and the downlink physical channel setup according to Annex C.3.2.

For CA with 2 DL CCs, the requirements are specified in Table 8.2.2.4.3-4, with the addition of the parameters in Table 8.2.2.4.3-3 and the downlink physical channel setup according to Annex C.3.2. The purpose of these tests is to verify the closed loop rank-two performance with wideband and frequency selective precoding.

For CA with 3 DL CCs, the requirements are specified in Table 8.2.2.4.3-7, based on single carrier requirement specified in Table 8.2.2.4.3-5, with the addition of the parameters in Table 8.2.2.4.3-3 and the downlink physical channel setup according to Annex C.3.2.

The test coverage for different number of component carriers is defined in 8.1.2.4.

Table 8.2.2.4.3-1: Test Parameters for Multi-Layer Spatial Multiplexing (FRC)

Parameter	Unit	Test 1	
Downlink power allocation	ρ_A	dB	-6
	ρ_B	dB	-6 (Note 1)
	σ	dB	3
N_{oc} at antenna port	dBm/15kHz	-98	
Precoding granularity	PRB	6	
PMI delay (Note 2)	ms	10 or 11	
Reporting interval	ms	1 or 4 (Note 3)	
Reporting mode		PUSCH 1-2	
ACK/NACK feedback mode		Bundling	
CodeBookSubsetRestriction bitmap		00000000000000000000000000000000 00001111111111111111111100000000 00000000	
PDSCH transmission mode		4	
Note 1: $P_B = 1$. Note 2: If the UE reports in an available uplink reporting instance at subframe SF#n based on PMI estimation at a downlink SF not later than SF#(n-4), this reported PMI cannot be applied at the eNB downlink before SF#(n+4) Note 3: For Uplink - downlink configuration 1 the reporting interval will alternate between 1ms and 4ms. Note 4: Void. Note 5: Void. Note 6: Void.			

Table 8.2.2.4.3-2: Minimum performance Multi-Layer Spatial Multiplexing (FRC)

Test number	Bandwidth	Reference Channel	OCNG Pattern	Propagation Condition	Correlation Matrix and Antenna Configuration	Reference value		UE Category
						Fraction of Maximum Throughput (%)	SNR (dB)	
1	10 MHz	R.36 TDD	OP.1 TDD	EPA5	4x2 Low	70	15.7	≥ 2
Note 1: Void								

Table 8.2.2.4.3-3: Test Parameters for Multi-Layer Spatial Multiplexing (FRC) for CA

Parameter	Unit	Value	
Downlink power allocation	ρ_A	dB	-6
	ρ_B	dB	-6 (Note 1)
	σ	dB	3
N_{oc} at antenna port	dBm/15kHz	-98	
Precoding granularity	PRB	8	
PMI delay (Note 2)	ms	10 or 11	
Reporting interval	ms	1 or 4 (Note 3)	
Reporting mode		PUSCH 1-2	
ACK/NACK feedback mode		PUCCH format 1b with channel selection for Tests in Table 8.2.2.4.3-4; PUCCH format 3 for Tests in Table 8.2.2.4.3-7	
CodeBookSubsetRestriction bitmap		00000000000000000000000000000000 00001111111111111111111100000000 00000000	
CSI request field (Note 4)		'10'	
PDSCH transmission mode		4	
Note 1: $P_B = 1$. Note 2: If the UE reports in an available uplink reporting instance at subframe SF#n based on PMI estimation at a downlink SF not later than SF#(n-4), this reported PMI cannot be applied at the eNB downlink before SF#(n+4) Note 3: For Uplink - downlink configuration 1 the reporting interval will alternate between 1ms and 4ms. Note 4: Multiple CC-s under test are configured as the 1 st set of serving cells by high layers. Note 5: The same PDSCH transmission mode is applied to each component carrier.			

Table 8.2.2.4.3-4: Minimum performance Multi-Layer Spatial Multiplexing (FRC) for CA with 2DL CCs

Test number	Bandwidth	Reference Channel	OCNG Pattern	Propagation Condition	Correlation Matrix and Antenna Configuration	Reference value		UE Category
						Fraction of Maximum Throughput (%)	SNR (dB)	
1	2x20 MHz	R.43 TDD	OP.1 TDD (Note 1)	EVA5	4x2 Low	70	11.1	≥5
2	20MHz +15MHz z	R.43 TDD for 20MHz CC	OP.1 TDD (Note 1)	EVA5	4x2 Low	70	10.7	≥5
		R.43-5 TDD for 15MHz CC	OP.1 TDD (Note 1)				10.6	
Note 1: The OCNG pattern applies for each CC. Note 2: The applicability of requirements for different CA configurations and bandwidth combination sets is defined in 8.1.2.3.								

Table 8.2.2.4.3-5: Single carrier performance for multiple CA configurations

Band-width	Reference channel	OCNG pattern	Propagation condition	Correlation matrix and antenna config.	Reference value	
					Fraction of maximum throughput (%)	SNR (dB)
1.4MHz	R.43-1 TDD	OP.1 TDD	EVA5	4x2 Low	70	11.0
3MHz	R.43-2 TDD	OP.1 TDD	EVA5	4x2 Low	70	9.8
5MHz	R.43-3 TDD	OP.1 TDD	EVA5	4x2 Low	70	10.0
10 MHz	R.43-4 TDD	OP.1 TDD	EVA5	4x2 Low	70	10.5
15MHz	R.43-5 TDD	OP.1 TDD	EVA5	4x2 Low	70	10.6
20MHz	R.43 TDD	OP. 1 TDD	EVA5	4x2 Low	70	10.7

Table 8.2.2.4.3-6: Void**Table 8.2.2.4.3-7: Minimum performance (FRC) based on single carrier performance for CA with 3 DL CCs**

Test num.	CA Band-width combination	Requirement	UE category
1	3x20MHz	As specified in Table 8.2.2.4.3-5 per CC	≥5
2	20MHz+20MHz+15MHz	As specified in Table 8.2.2.4.3-5 per CC	≥5
Note 1: The applicability of requirements for different CA configurations and bandwidth combination sets is defined in 8.1.2.3			

8.2.2.4.3A Minimum Requirement Multi-Layer Spatial Multiplexing 4 Tx Antenna Port for dual connectivity

For dual connectivity the requirements are specified in Table 8.2.2.4.3A-3, based on single carrier requirement specified in Table 8.2.2.4.3A-2, with the addition of the parameters in Table 8.2.2.4.3A-1 and the downlink physical channel setup according to Annex C.3.2. The purpose of these tests is to verify the closed loop rank-two performance with wideband and frequency selective precoding by using dual connectivity.

Table 8.2.2.4.3A-1: Test Parameters for Multi-Layer Spatial Multiplexing (FRC) for dual connectivity

Parameter	Unit	Value	
Downlink power allocation	ρ_A	dB	-6
	ρ_B	dB	-6 (Note 1)
	σ	dB	3
N_{oc} at antenna port	dBm/15kHz	-98	
Precoding granularity	PRB	6 for 1.4MHz, 4 for 3MHz and 5MHz CCs, 6 for 10MHz CCs, and 8 for 15MHz CCs and 20MHz CCs	
PMI delay (Note 2)	ms	10 or 11	
Reporting interval	ms	1 or 4 (Note 3)	
Reporting mode		PUSCH 1-2	
CodeBookSubsetRestriction bitmap		00000000000000000000000000000000 000011111111111111111100000000 00000000	
PDSCH transmission mode		4	
ACK/NACK transmission		Separate ACK/NACK feedbacks with PUCCH format 1b on the MCG and SCG	
CSI feedback		Separate PUSCH feedbacks on the MCG and SCG	
Time offset between MCG CC and SCG CC	μ s	0 for UE under test supporting synchronous dual connectivity; 334 for UE under test supporting both asynchronous and synchronous dual connectivity (Note 5)	
<p>Note 1: $P_B = 1$.</p> <p>Note 2: If the UE reports in an available uplink reporting instance at subframe SF#n based on PMI estimation at a downlink SF not later than SF#(n-4), this reported PMI cannot be applied at the eNB downlink before SF#(n+4)</p> <p>Note 3: For Uplink - downlink configuration 1 the reporting interval will alternate between 1ms and 4ms.</p> <p>Note 4: The same PDSCH transmission mode is applied to each component carrier.</p> <p>Note 5: As defined in TS36.300 [11].</p> <p>Note 6: If the UE supports both SCG bearer and Split bearer, the SCG bearer is configured.</p>			

Table 8.2.2.4.3A-2: Single carrier performance for multiple dual connectivity configurations

Band-width	Reference channel	OCNG pattern	Propagation condition	Correlation matrix and antenna config.	Reference value	
					Fraction of maximum throughput (%)	SNR (dB)
1.4MHz	R.43-1 TDD	OP.1 TDD	EVA5	4x2 Low	70	11.0
3MHz	R.43-2 TDD	OP.1 TDD	EVA5	4x2 Low	70	9.8
5MHz	R.43-3 TDD	OP.1 TDD	EVA5	4x2 Low	70	10.0
10 MHz	R.43-4 TDD	OP.1 TDD	EVA5	4x2 Low	70	10.5
15MHz	R.43-5 TDD	OP.1 TDD	EVA5	4x2 Low	70	10.6
20MHz	R.43 TDD	OP.1 TDD	EVA5	4x2 Low	70	10.7

Table 8.2.2.4.3A-3: Minimum performance Multi-Layer Spatial Multiplexing (FRC) for dual connectivity

Test num.	Band-width combination	Requirement	UE category
-----------	------------------------	-------------	-------------

1	2x20 MHz	As specified in Table 8.2.2.4.3A-2 per CC	≥5
Note 1: The OCNG pattern applies for each CC.			
Note 2: The applicability of requirements for different dual connectivity configurations and bandwidth combination sets is defined in 8.1.2.3A.			

8.2.2.4.4 Void

8.2.2.5 MU-MIMO

8.2.2.6 [Control channel performance: D-BCH and PCH]

8.2.2.7 Carrier aggregation with power imbalance

The requirements in this section verify the ability of an intraband adjacent carrier aggregation UE to demodulate the signal transmitted by the PCell or SCell in the presence of a stronger SCell or PCell signal on an adjacent frequency. Throughput is measured on the PCell or SCell only.

8.2.2.7.1 Minimum Requirement

For CA, the requirements are specified in Table 8.2.2.7.1-2, with the addition of the parameters in Table 8.2.2.7.1-1 and the downlink physical channel setup according to Annex C.3.2.

Table 8.2.2.7.1-1: Test Parameters for CA

Parameter		Unit	Test 1	Test 2
Downlink power allocation	ρ_A	dB	0	0
	ρ_B	dB	0 (Note 1)	0 (Note 1)
	σ	dB	0	0
N_{oc} at antenna port		dBm/15kHz	Off (Note 2)	Off (Note 2)
Symbols for unused PRBs			OCNG (Note 3)	OCNG (Note 3)
Modulation			64 QAM	64 QAM
Maximum number of HARQ transmission			1	1
Redundancy version coding sequence			{0}	{0}
PDSCH transmission mode of PCell			1	3
PDSCH transmission mode of SCell			3	1
OCNG Pattern	PCell		OP.1 TDD	OP.5 TDD
	SCell		OP.5 TDD	OP.1 TDD
Propagation Conditions	PCell		Clause B.1	Clause B.1
	SCell		Clause B.1	Clause B.1
Correlation Matrix and Antenna	PCell		1x2	2x2
	SCell		2x2	1x2
Note 1: $P_B = 0$ for 1x2 and $P_B = 1$ for 2x2 antenna configuration.				
Note 2: No external noise sources are applied.				
Note 3: These physical resource blocks are assigned to an arbitrary number of virtual UEs with one PDSCH per virtual UE; the data transmitted over the OCNG PDSCHs shall be uncorrelated pseudo random data.				
Note 4: Void.				

Table 8.2.2.7.1-2: Minimum performance (FRC) for CA

Test Number	Bandwidth (MHz)		Reference channel		Power at antenna port (dBm/15KHz)		Reference value Fraction of Maximum Throughput (%)		UE Category
	PCell	SCell	PCell	SCell	\hat{E}_{s_PCell} for PCell	\hat{E}_{s_SCell} for SCell	PCell	SCell	
1	20	20	R.49 TDD	NA	-85	-79	85	NA	≥ 5
2	20	15	NA	R.49-1 TDD	-79	-85.8	NA	85	≥ 5
Note 1:	The OCNG pattern for PCell is used to fill the control channel. The OCNG pattern for SCell is used to fill the control channel and PDSCH.								
Note 2:	The applicability of requirements for different CA configurations and bandwidth combination sets is defined in 8.1.2.3.								

8.2.2.8 Intra-band contiguous carrier aggregation with minimum channel spacing

The requirements in this section verify the ability of an UE supporting intraband contiguous carrier aggregation with minimum channel spacing to demodulate the signal transmitted by the PCell and SCell(s). Throughput is measured on each cell. The minimum channel spacing of intra-band contiguous carrier aggregation refers to the possible minimum channel spacing as any multiple of 300 kHz less than the nominal channel spacing defined in 5.7.1A.

8.2.2.8.1 Minimum Requirement

For CA the requirements are specified in Table 8.2.2.8.1-2, with the addition of the parameters in Table 8.2.2.8.1-1 and the downlink physical channel setup according to Annex C.3.2.

Table 8.2.2.8.1-1: Test Parameters for CA

Parameter		Unit	Test 1-2
Downlink power allocation	ρ_A	dB	0
	ρ_B	dB	0 (Note 1)
	σ	dB	0
N_{oc} at antenna port		dBm/15kHz	-98
Symbols for unused PRBs			OCNG (Note 2)
Modulation			64QAM
ACK/NACK feedback mode			PUCCH format 1b with channel selection for Test 1; PUCCH format 3 for Test 2
PDSCH transmission mode			1
Note 1:	$P_B = 0$		
Note 2:	These physical resource blocks are assigned to an arbitrary number of virtual UEs with one PDSCH per virtual UE; the data transmitted over the OCNG PDSCHs shall be uncorrelated pseudo random data, which is QPSK modulated.		
Note 3:	The same PDSCH transmission mode is applied to each component carrier.		

Table 8.2.2.8.1-2: Minimum performance (FRC) for intra-band CA with minimum channel spacing

Test number	Bandwidth	Reference Channel	OCNG Pattern	Propagation Condition	Correlation Matrix and Antenna Configuration	Reference value		UE Category
						Fraction of Maximum Throughput (%)	SNR (dB)	
1	2x20MHz	R.9 TDD	OP.1 TDD (Note 1)	EVA5	1x2 Low	70	17.16	≥5
		R.9 TDD	OP.1 TDD (Note 1)			70	17.16	
2	3x20MHz	R.9 TDD	OP.1 TDD (Note 1)	EVA5	1x2 Low	70	17.16	≥5
		R.9 TDD	OP.1 TDD (Note 1)			70	17.16	
		R.9 TDD	OP.1 TDD (Note 1)			70	17.16	

Note 1: The OCNG pattern applies for each CC.
Note 2: The applicability and test rules of requirements for different CA configurations and bandwidth combination sets are defined in 8.1.2.3.

8.2.3 TDD FDD CA (Fixed Reference Channel)

The parameters specified in Table 8.2.3-1 are valid for all the TDD FDD CA tests unless otherwise stated.

Table 8.2.3-1: Common Test Parameters

Parameter		Unit	Value
Uplink downlink configuration (Note 1) for TDD CC only			1
Special subframe configuration (Note 2) for TDD CC only			4
Inter-TTI Distance			1
Maximum number of HARQ processes per component carrier	FDD PCell	Processes	8 for FDD and TDD CCs
	TDD PCell	Processes	11 for FDD CC; 7 for TDD CC
Maximum number of HARQ transmission			4
Redundancy version coding sequence			{0,1,2,3} for QPSK and 16QAM {0,0,1,2} for 64QAM
Number of OFDM symbols for PDCCH per component carrier		OFDM symbols	4 for 1.4 MHz bandwidth, 3 for 3 MHz and 5 MHz bandwidths, 2 for 10 MHz, 15 MHz and 20 MHz bandwidths
Cyclic Prefix			Normal
Cell_ID			0
Cross carrier scheduling			Not configured
ACK/NACK feedback mode			PUCCH format 3
Downlink HARQ-ACK timing	FDD PCell		As specified in Clause 7.3.3 in TS36.213 [6]
	TDD PCell		As specified in Clause 7.3.4 in TS36.213 [6]

Note 1: as specified in Table 4.2-2 in TS 36.211 [4].
Note 2: as specified in Table 4.2-1 in TS 36.211 [4].

The applicability of their requirements are specified in Clause 8.1.2.3. The single carrier performance with different bandwidths for multiple CA configurations specified in Clause 8.2.3 cannot be applied for UE single carrier test.

8.2.3.1 Single-antenna port performance

The single-antenna performance in a given multi-path fading environments is determined by the SNR for which a certain relative information bit throughput of the reference measurement channels in Annex A.3.3 is achieved. The purpose of these tests is to verify the single-antenna performance with different channel models and MCS.

8.2.3.1.1 Minimum Requirement for FDD PCell

For TDD FDD CA with FDD PCell and 2DL CCs, the requirements are specified in Table 8.2.3.1.1-4 based on single carrier requirement specified in Table 8.2.3.1.1-2 and Table 8.2.3.1.1-3, with the addition of the parameters in Table 8.2.3.1.1-1 and the downlink physical channel setup according to Annex C.3.2.

For TDD FDD CA with FDD PCell and 3DL CCs, the requirements are specified in Table 8.2.3.1.1-5 based on single carrier requirement specified in Table 8.2.3.1.1-2 and Table 8.2.3.1.1-3, with the addition of the parameters in Table 8.2.3.1.1-1 and the downlink physical channel setup according to Annex C.3.2.

The test coverage for different number of component carriers is defined in 8.1.2.4.

Table 8.2.3.1.1-1: Test Parameters for CA

Parameter	Unit	Value	
Downlink power allocation	ρ_A	dB	0
	ρ_B	dB	0 (Note 1)
	σ	dB	0
N_{oc} at antenna port	dBm/15kHz	-98	
Symbols for unused PRBs		OCNG (Note 2)	
Modulation		QPSK	
PDSCH transmission mode		1	
Note 1: $P_B = 0$.			
Note 2: These physical resource blocks are assigned to an arbitrary number of virtual UEs with one PDSCH per virtual UE; the data transmitted over the OCNG PDSCHs shall be uncorrelated pseudo random data, which is QPSK modulated.			
Note 3: The same PDSCH transmission mode is applied to each component carrier.			

Table 8.2.3.1.1-2: Single carrier performance with different bandwidths for multiple CA configurations for FDD PCell and SCell (FRC)

Band-width	Reference Channel	OCNG Pattern	Propagation Condition	Correlation Matrix and Antenna Configuration	Reference value	
					Fraction of Maximum Throughput (%)	SNR (dB)
1.4 MHz	R.4 FDD	OP.1 FDD	EVA5	1x2 Low	70	-1.3
3 MHz	R.42-1 FDD	OP.1 FDD	EVA5	1x2 Low	70	-1.1
5MHz	R.42-2 FDD	OP.1 FDD	EVA5	1x2 Low	70	-1.0
10MHz	R.2 FDD	OP.1 FDD	EVA5	1x2 Low	70	-1.7
15MHz	R.42-3 FDD	OP.1 FDD	EVA5	1x2 Low	70	-1.6
20MHz	R.42 FDD	OP.1 FDD	EVA5	1x2 Low	70	-1.7

Table 8.2.3.1.1-3: Single carrier performance with different bandwidths for multiple CA configurations for TDD SCell (FRC)

Band-width	Reference Channel	OCNG Pattern	Propagation Condition	Correlation Matrix and Antenna Configuration	Reference value	
					Fraction of Maximum Throughput (%)	SNR (dB)
1.4 MHz	R.4 TDD	OP.1 TDD	EVA5	1x2 Low	70	-0.6
3 MHz	R.42-1 TDD	OP.1 TDD	EVA5	1x2 Low	70	-0.8
5MHz	R.42-2 TDD	OP.1 TDD	EVA5	1x2 Low	70	-1.2
10MHz	R.2 TDD	OP.1 TDD	EVA5	1x2 Low	70	-1.6
15MHz	R.42-3 TDD	OP.1 TDD	EVA5	1x2 Low	70	-1.4
20MHz	R.42 TDD	OP.1 TDD	EVA5	1x2 Low	70	-1.4

Table 8.2.3.1.1-4: Minimum performance for multiple CA configurations with 2DL CCs (FRC)

Test number	CA Bandwidth combination (MHz)			Minimum performance requirement	UE Category
	Total	FDD CC	TDD CC		
1	2x20	20	20	As defined in Table 8.2.3.1.1-2 and Table 8.2.3.1.1-3 per CC	≥5
2	20+10	10	20	As defined in Table 8.2.3.1.1-2 and Table 8.2.3.1.1-3 per CC	≥5
3	20+15	15	20	As defined in Table 8.2.3.1.1-2 and Table 8.2.3.1.1-3 per CC	≥5
Note 1:	The applicability of requirements for different CA configurations and bandwidth combination sets is defined in 8.1.2.3B.				
Note 2:	30usec timing difference between PCell and any SCell is applied in inter-band CA case, where PCell can be assigned on any FDD CC.				

Table 8.2.3.1.1-5: Minimum performance for multiple CA configurations with 3DL CCs (FRC)

Test number	CA Bandwidth combination (MHz)			Minimum performance requirement	UE Category
	Total	FDD CC	TDD CC		
1	3x20	20	2x20	As defined in Table 8.2.3.1.1-2 and Table 8.2.3.1.1-3 per CC	≥5
2	20+20+15	15	2x20	As defined in Table 8.2.3.1.1-2 and Table 8.2.3.1.1-3 per CC	≥5
3	20+20+10	10	2x20	As defined in Table 8.2.3.1.1-2 and Table 8.2.3.1.1-3 per CC	≥5
Note 1:	The applicability of requirements for different CA configurations and bandwidth combination sets is defined in 8.1.2.3B.				
Note 2:	30usec timing difference between PCell and any SCell is applied in inter-band CA case, where PCell can be assigned on any FDD CC.				

8.2.3.1.2 Minimum Requirement for TDD PCell

For TDD FDD CA with TDD PCell and 2DL CCs, the requirements are specified in Table 8.2.3.1.2-4 based on single carrier requirement specified in Table 8.2.3.1.2-2 and Table 8.2.3.1.2-3, with the addition of the parameters in Table 8.2.3.1.2-1 and the downlink physical channel setup according to Annex C.3.2.

For TDD FDD CA with TDD PCell with 3DL CCs, the requirements are specified in Table 8.2.3.1.2-5 based on single carrier requirement specified in Table 8.2.3.1.2-2 and Table 8.2.3.1.2-3, with the addition of the parameters in Table 8.2.3.1.2-1 and the downlink physical channel setup according to Annex C.3.2.

The test coverage for different number of component carriers is defined in 8.1.2.4.

Table 8.2.3.1.2-1: Test Parameters for CA

Parameter		Unit	Value
Downlink power allocation	ρ_A	dB	0
	ρ_B	dB	0 (Note 1)
	σ	dB	0
N_{oc} at antenna port		dBm/15kHz	-98
Symbols for unused PRBs			OCNG (Note 2)
Modulation			QPSK
PDSCH transmission mode			1
Note 1: $P_B = 0$.			
Note 2: These physical resource blocks are assigned to an arbitrary number of virtual UEs with one PDSCH per virtual UE; the data transmitted over the OCNG PDSCHs shall be uncorrelated pseudo random data, which is QPSK modulated.			
Note 3: The same PDSCH transmission mode is applied to each component carrier.			

Table 8.2.3.1.2-2: Single carrier performance with different bandwidths for multiple CA configurations for FDD SCell (FRC)

Band-width	Reference Channel	OCNG Pattern	Propagation Condition	Correlation Matrix and Antenna Configuration	Reference value	
					Fraction of Maximum Throughput (%)	SNR (dB)
1.4 MHz	R.4 FDD	OP.1 FDD	EVA5	1x2 Low	70	-1.3
3 MHz	R.42-1 FDD	OP.1 FDD	EVA5	1x2 Low	70	-1.1
5MHz	R.42-2 FDD	OP.1 FDD	EVA5	1x2 Low	70	-1.0
10MHz	R.2 FDD	OP.1 FDD	EVA5	1x2 Low	70	-1.7
15MHz	R.42-3 FDD	OP.1 FDD	EVA5	1x2 Low	70	-1.6
20MHz	R.42 FDD	OP.1 FDD	EVA5	1x2 Low	70	-1.7

Table 8.2.3.1.2-3: Single carrier performance with different bandwidths for multiple CA configurations for TDD PCell and SCell (FRC)

Band-width	Reference Channel	OCNG Pattern	Propagation Condition	Correlation Matrix and Antenna Configuration	Reference value	
					Fraction of Maximum Throughput (%)	SNR (dB)
1.4 MHz	R.4 TDD	OP.1 TDD	EVA5	1x2 Low	70	-0.6
3 MHz	R.42-1 TDD	OP.1 TDD	EVA5	1x2 Low	70	-0.8
5MHz	R.42-2 TDD	OP.1 TDD	EVA5	1x2 Low	70	-1.2
10MHz	R.2 TDD	OP.1 TDD	EVA5	1x2 Low	70	-1.6
15MHz	R.42-3 TDD	OP.1 TDD	EVA5	1x2 Low	70	-1.4
20MHz	R.42 TDD	OP.1 TDD	EVA5	1x2 Low	70	-1.4

Table 8.2.3.1.2-4: Minimum performance for multiple CA configurations with 2DL CCs (FRC)

Test number	Aggregated Bandwidth (MHz)			Minimum performance requirement	UE Category
	Total	FDD CC	TDD CC		
1	2x20	20	20	As defined in Table 8.2.3.1.2-2 and Table 8.2.3.1.2-3 per CC	≥5
2	20+10	10	20	As defined in Table 8.2.3.1.2-2 and Table 8.2.3.1.2-3 per CC	≥5
3	20+15	15	20	As defined in Table 8.2.3.1.2-2 and Table 8.2.3.1.2-3 per CC	≥5
Note 1:	The applicability of requirements for different CA configurations and bandwidth combination sets is defined in 8.1.2.3B				
Note 2:	30usec timing difference between PCell and any SCell is applied in inter-band CA case, where PCell can be assigned on any TDD CC.				

Table 8.2.3.1.2-5: Minimum performance for multiple CA configurations with 3DL CCs (FRC)

Test number	Aggregated Bandwidth (MHz)			Minimum performance requirement	UE Category
	Total	FDD CC	TDD CC		
1	3x20	20	2x20	As defined in Table 8.2.3.1.2-2 and Table 8.2.3.1.2-3 per CC	≥5
2	20+20+15	15	2x20	As defined in Table 8.2.3.1.2-2 and Table 8.2.3.1.2-3 per CC	≥5
3	20+20+10	10	2x20	As defined in Table 8.2.3.1.2-2 and Table 8.2.3.1.2-3 per CC	≥5
Note 1:	The applicability of requirements for different CA configurations and bandwidth combination sets is defined in 8.1.2.3B.				
Note 2:	30usec timing difference between PCell and any SCell is applied in inter-band CA case, where PCell can be assigned on any TDD CC.				

8.2.3.2 Open-loop spatial multiplexing performance 2Tx Antenna port

8.2.3.2.1 Minimum Requirement for FDD PCell

For TDD FDD CA with FDD PCell and 2DL CCs, the requirements are specified in Table 8.2.3.2.1-4 based on single carrier requirement specified in Table 8.2.3.2.1-2 and Table 8.2.3.2.1-3, with the addition of the parameters in Table 8.2.3.2.1-1 and the downlink physical channel setup according to Annex C.3.2. The purpose is to verify the performance of large delay CDD with 2 transmitter antennas.

For TDD FDD CA with FDD PCell and 3DL CCs, the requirements are specified in Table 8.2.3.2.1-5 based on single carrier requirement specified in Table 8.2.3.2.1-2 and Table 8.2.3.2.1-3, with the addition of the parameters in Table 8.2.3.2.1-1 and the downlink physical channel setup according to Annex C.3.2. The purpose is to verify the performance of large delay CDD with 2 transmitter antennas.

The test coverage for different number of component carriers is defined in 8.1.2.4.

Table 8.2.3.2.1-1: Test Parameters for Large Delay CDD (FRC) for CA

Parameter	Unit	Value
Downlink power allocation	ρ_A	dB
	ρ_B	dB
	σ	dB
N_{oc} at antenna port	dBm/15kHz	-98
PDSCH transmission mode		3
Note 1: $P_B = 1$.		
Note 2: The same PDSCH transmission mode is applied to each component carrier.		

Table 8.2.3.2.1-2: Single carrier performance with different bandwidths for multiple CA configurations for FDD PCell and SCell (FRC)

Band-width	Reference Channel	OCNG Pattern	Propagation Condition	Correlation Matrix and Antenna Configuration	Reference value	
					Fraction of Maximum Throughput (%)	SNR (dB)
1.4 MHz	R.11-5 FDD	OP.1 FDD	EVA70	2x2 Low	70	13.6
3 MHz	R.11-6 FDD	OP.1 FDD	EVA70	2x2 Low	70	12.3
5MHz	R.11-2 FDD	OP.1 FDD	EVA70	2x2 Low	70	12.3
10MHz	R.11 FDD	OP.1 FDD	EVA70	2x2 Low	70	12.9
15MHz	R.11-7 FDD	OP.1 FDD	EVA70	2x2 Low	70	12.8
20MHz	R.30 FDD	OP.1 FDD	EVA70	2x2 Low	70	12.9

Table 8.2.3.2.1-3: Single carrier performance with different bandwidths for multiple CA configurations for TDD SCell (FRC)

Band-width	Reference Channel	OCNG Pattern	Propagation Condition	Correlation Matrix and Antenna Configuration	Reference value	
					Fraction of Maximum Throughput (%)	SNR (dB)
1.4 MHz	R.11-5 TDD	OP.1 TDD	EVA70	2x2 Low	70	13.2
3 MHz	R.11-6 TDD	OP.1 TDD	EVA70	2x2 Low	70	12.8
5MHz	R.11-7 TDD	OP.1 TDD	EVA70	2x2 Low	70	12.6
10MHz	R.11-8 TDD	OP.1 TDD	EVA70	2x2 Low	70	12.8
15MHz	R.11-9 TDD	OP.1 TDD	EVA70	2x2 Low	70	12.9
20MHz	R.30-1 TDD	OP.1 TDD	EVA70	2x2 Low	70	13.0

Table 8.2.3.2.1-4: Minimum performance for multiple CA configurations with 2DL CCs (FRC)

Test number	Aggregated Bandwidth (MHz)			Minimum performance requirement	UE Category
	Total	FDD CC	TDD CC		
1	2x20	20	20	As defined in Table 8.2.3.2.1-2 and Table 8.2.3.2.1-3 per CC	≥5
2	20+10	10	20	As defined in Table 8.2.3.2.1-2 and Table 8.2.3.2.1-3 per CC	≥5
3	20+15	15	20	As defined in Table 8.2.3.2.1-2 and Table 8.2.3.2.1-3 per CC	≥5
Note 1:	The applicability of requirements for different CA configurations and bandwidth combination sets is defined in 8.1.2.3B				

Table 8.2.3.2.1-5: Minimum performance for multiple CA configurations with 3DL CCs (FRC)

Test number	Aggregated Bandwidth (MHz)			Minimum performance requirement	UE Category
	Total	FDD CC	TDD CC		
1	3x20	20	2x20	As defined in Table 8.2.3.2.1-2 and Table 8.2.3.2.1-3 per CC	≥5
2	20+20+15	15	2x20	As defined in Table 8.2.3.2.1-2 and Table 8.2.3.2.1-3 per CC	≥5
3	20+20+10	10	2x20	As defined in Table 8.2.3.2.1-2 and Table 8.2.3.2.1-3 per CC	≥5
Note 1:	The applicability of requirements for different CA configurations and bandwidth combination sets is defined in 8.1.2.3B.				

8.2.3.2.1A Soft buffer management test for FDD PCell

For TDD-FDD CA, the requirements are specified in Table 8.2.3.2.1A-2, with the addition of the parameters in Table 8.2.3.2.1A-1 and the downlink physical channel setup according to Annex C.3.2. The purpose is to verify the UE performance with proper instantaneous buffer implementation for FDD as PCell.

Table 8.2.3.2.1A-1: Test Parameters for CA

Parameter		Unit	Value	
			FDD Carrier	TDD Carrier
Downlink power allocation	ρ_A	dB	-3	-3
	ρ_B	dB	-3 (Note 1)	-3 (Note 1)
	σ	dB	0	0
N_{oc} at antenna port		dBm/15kHz	-98	-98
PDSCH transmission mode			3	3

Note 1: $P_B = 1$.

Note 2: The same PDSCH transmission mode is applied to each component carrier.

Table 8.2.3.2.1A-2: Minimum performance (FRC) for CA

Test num.	Band-width		Reference channel	OCNG pattern	Propagation condition	Correlation matrix and antenna config	Reference value		UE category
							Fraction of maximum throughput (%)	SNR (dB)	
1	PCell	20MHz	R.30 FDD	OP.1 FDD (Note 1)	EVA70	2x2 Low	70	13.2	3
	SCell	20MHz	R.30-2 TDD	OP.1 TDD (Note 1)			70	13.2	
2	PCell	20MHz	R.35-1 FDD	OP.1 FDD (Note 1)	EVA70	2x2 Low	70	16.3	4
	SCell	20MHz	R.35-1 TDD	OP.1 TDD (Note 1)			70	16.3	
3	PCell	10MHz	R.35-3 FDD	OP.1 FDD (Note 1)	EVA70	2x2 Low	70	16.0	3
	SCell	20MHz	R.30-2 TDD	OP.1 TDD (Note 1)			70	13.2	
4	PCell	10MHz	R.35-3 FDD	OP.1 FDD (Note 1)	EVA70	2x2 Low	70	16.0	4
	SCell	20MHz	R.35-1 TDD	OP.1 TDD (Note 1)			70	16.3	
5	PCell	15MHz	R.35-2 FDD	OP.1 FDD (Note 1)	EVA70	2x2 Low	70	16.0	3
	SCell	20MHz	R.30-2 TDD	OP.1 TDD (Note 1)			70	13.2	
6	PCell	15MHz	R.35-2 FDD	OP.1 FDD (Note 1)	EVA70	2x2 Low	70	16.0	4
	SCell	20MHz	R.35-1 TDD	OP.1 TDD (Note 1)			70	16.3	

Note 1: The OCNG pattern applies for each CC.

Note 2: The applicability and test rules of requirements for different CA configurations and bandwidth combination sets are defined in 8.1.2.3B.

8.2.3.2.2 Minimum Requirement for TDD PCell

For TDD FDD CA with TDD PCell and 2DL CCs, the requirements are specified in Table 8.2.3.2.2-4 based on single carrier requirement specified in Table 8.2.3.2.2-2 and Table 8.2.3.2.2-3, with the addition of the parameters in Table

8.2.3.2.2-1 and the downlink physical channel setup according to Annex C.3.2. The purpose is to verify the performance of large delay CDD with 2 transmitter antennas.

For TDD FDD CA with TDD PCell and 3DL CCs, the requirements are specified in Table 8.2.3.2.2-5 based on single carrier requirement specified in Table 8.2.3.2.2-2 and Table 8.2.3.2.2-3, with the addition of the parameters in Table 8.2.3.2.2-1 and the downlink physical channel setup according to Annex C.3.2. The purpose is to verify the performance of large delay CDD with 2 transmitter antennas.

The test coverage for different number of component carriers is defined in 8.1.2.4.

Table 8.2.3.2.2-1: Test Parameters for Large Delay CDD (FRC) for CA

Parameter	Unit	Value	
Downlink power allocation	ρ_A	dB	-3
	ρ_B	dB	-3 (Note 1)
	σ	dB	0
N_{oc} at antenna port	dBm/15kHz	-98	
PDSCH transmission mode		3	
Note 1: $P_B = 1$.			
Note 2: The same PDSCH transmission mode is applied to each component carrier.			

Table 8.2.3.2.2-2: Single carrier performance with different bandwidths for multiple CA configurations for FDD SCell (FRC)

Band-width	Reference Channel	OCNG Pattern	Propagation Condition	Correlation Matrix and Antenna Configuration	Reference value	
					Fraction of Maximum Throughput (%)	SNR (dB)
1.4 MHz	R.11-5 FDD	OP.1 FDD	EVA70	2x2 Low	70	13.6
3 MHz	R.11-6 FDD	OP.1 FDD	EVA70	2x2 Low	70	12.3
5MHz	R.11-2 FDD	OP.1 FDD	EVA70	2x2 Low	70	12.3
10MHz	R.11 FDD	OP.1 FDD	EVA70	2x2 Low	70	12.9
15MHz	R.11-7 FDD	OP.1 FDD	EVA70	2x2 Low	70	12.8
20MHz	R.30 FDD	OP.1 FDD	EVA70	2x2 Low	70	12.9

Table 8.2.3.2.2-3: Single carrier performance with different bandwidths for multiple CA configurations for TDD PCell and SCell (FRC)

Band-width	Reference Channel	OCNG Pattern	Propagation Condition	Correlation Matrix and Antenna Configuration	Reference value	
					Fraction of Maximum Throughput (%)	SNR (dB)
1.4 MHz	R.11-5 TDD	OP.1 TDD	EVA70	2x2 Low	70	13.2
3 MHz	R.11-6 TDD	OP.1 TDD	EVA70	2x2 Low	70	12.8
5MHz	R.11-7 TDD	OP.1 TDD	EVA70	2x2 Low	70	12.6
10MHz	R.11-8 TDD	OP.1 TDD	EVA70	2x2 Low	70	12.8
15MHz	R.11-9 TDD	OP.1 TDD	EVA70	2x2 Low	70	12.9
20MHz	R.30-1 TDD	OP.1 TDD	EVA70	2x2 Low	70	13.0

Table 8.2.3.2.2-4: Minimum performance for multiple CA configurations with 2DL CCs (FRC)

Test number	Aggregated Bandwidth (MHz)			Minimum performance requirement	UE Category
	Total	FDD CC	TDD CC		
1	2x20	20	20	As defined in Table 8.2.3.2.2-2 and Table 8.2.3.2.2-3 per CC	≥5
2	20+10	10	20	As defined in Table 8.2.3.2.2-2 and Table 8.2.3.2.2-3 per CC	≥5
3	20+15	15	20	As defined in Table 8.2.3.2.2-2 and Table 8.2.3.2.2-3 per CC	≥5
Note 1: The applicability of requirements for different CA configurations and bandwidth combination sets is defined in 8.1.2.3B					

Table 8.2.3.2.2-5: Minimum performance for multiple CA configurations with 3DL CCs (FRC)

Test number	Aggregated Bandwidth (MHz)			Minimum performance requirement	UE Category
	Total	FDD CC	TDD CC		
1	3x20	20	2x20	As defined in Table 8.2.3.2.2-2 and Table 8.2.3.2.2-3 per CC	≥5
2	20+20+15	15	2x20	As defined in Table 8.2.3.2.2-2 and Table 8.2.3.2.2-3 per CC	≥5
3	20+20+10	10	2x20	As defined in Table 8.2.3.2.2-2 and Table 8.2.3.2.2-3 per CC	≥5
Note 1: The applicability of requirements for different CA configurations and bandwidth combination sets is defined in 8.1.2.3B.					

8.2.3.2.2A Soft buffer management test for TDD PCell

For TDD-FDD CA, the requirements are specified in Table 8.2.3.2.2A-2, with the addition of the parameters in Table 8.2.3.2.2A-1 and the downlink physical channel setup according to Annex C.3.2. The purpose is to verify the UE performance with proper instantaneous buffer implementation for TDD as PCell.

Table 8.2.3.2.2A-1: Test Parameters for CA

Parameter		Unit	Value	
			FDD Carrier	TDD Carrier
Downlink power allocation	ρ_A	dB	-3	-3
	ρ_B	dB	-3 (Note 1)	-3 (Note 1)
	σ	dB	0	0
N_{oc} at antenna port		dBm/15kHz	-98	-98
PDSCH transmission mode			3	3
Note 1: $P_B = 1$.				
Note 2: The same PDSCH transmission mode is applied to each component carrier.				

Table 8.2.3.2.2A-2: Minimum performance (FRC) for CA

Test num.	Band-width		Reference channel	OCNG pattern	Propagation condition	Correlation matrix and antenna config	Reference value		UE category
							Fraction of maximum throughput (%)	SNR (dB)	
1	PCell	20MHz	R.30-2 TDD	OP.1 TDD (Note 1))	EVA70	2x2 Low	70	13.2	3
	SCell	20MHz	R.30 FDD	OP.1 FDD (Note 1)			70	13.2	
2	PCell	20MHz	R.35-1 TDD	OP.1 TDD (Note 1)	EVA70	2x2 Low	70	16.2	4
	SCell	20MHz	R.35-1 FDD	OP.1 FDD (Note 1)			70	16.2	
3	PCell	20MHz	R.30-2 TDD	OP.1 TDD (Note 1)	EVA70	2x2 Low	70	13.2	3
	SCell	10MHz	R.35-3 FDD	OP.1 FDD (Note 1)			70	16.0	
4	PCell	20MHz	R.35-1 TDD	OP.1 TDD (Note 1)	EVA70	2x2 Low	70	16.2	4
	SCell	10MHz	R.35-3 FDD	OP.1 FDD (Note 1)			70	15.8	
5	PCell	20MHz	R.30-2 TDD	OP.1 TDD (Note 1)	EVA70	2x2 Low	70	13.2	3
	SCell	15MHz	R.35-2 FDD	OP.1 FDD (Note 1)			70	15.8	
6	PCell	20MHz	R.35-1 TDD	OP.1 TDD (Note 1)	EVA70	2x2 Low	70	16.2	4
	SCell	15MHz	R.35-2 FDD	OP.1 FDD (Note 1)			70	15.8	

Note 1: The OCNG pattern applies for each CC.
Note 2: The applicability and test rules of requirements for different CA configurations and bandwidth combination sets are defined in 8.1.2.3B.

8.2.3.3 Closed-loop spatial multiplexing performance 4Tx Antenna Port

8.2.3.3.1 Minimum Requirement for FDD PCell

For TDD FDD CA with FDD PCell and 2DL CCs, the requirements are specified in Table 8.2.3.3.1-4 based on single carrier requirement specified in Table 8.2.3.3.1-2 and Table 8.2.3.3.1-3, with the addition of the parameters in Table 8.2.3.3.1-1 and the downlink physical channel setup according to Annex C.3.2. The purpose of these tests is to verify the closed loop rank-two performance with wideband and frequency selective precoding.

For TDD FDD CA with FDD PCell and 3DL CCs, the requirements are specified in Table 8.2.3.3.1-5 based on single carrier requirement specified in Table 8.2.3.3.1-2 and Table 8.2.3.3.1-3, with the addition of the parameters in Table 8.2.3.3.1-1 and the downlink physical channel setup according to Annex C.3.2. The purpose of these tests is to verify the closed loop rank-two performance with wideband and frequency selective precoding.

The test coverage for different number of component carriers is defined in 8.1.2.4.

Table 8.2.3.3.1-1: Test Parameters for Multi-Layer Spatial Multiplexing (FRC) for CA

Parameter		Unit	Value
Downlink power allocation	ρ_A	dB	-6
	ρ_B	dB	-6 (Note 1)
	σ	dB	3
N_{oc} at antenna port		dBm/15kHz	-98
Precoding granularity		PRB	Wideband precoding for 1.4MHz, 4 for 3MHz and 5MHz CCs, 6 for 10MHz CCs, 8 for 15MHz and 20MHz CCs
PMI delay (Note 2)	FDD CC	ms	8
	TDD CC	ms	10 or 11
Reporting interval	FDD CC	ms	1
	TDD CC	ms	1 or 4 (Note 3)
Reporting mode			PUSCH 1-2
CodeBookSubsetRestriction bitmap			00000000000000000000000000000000 000011111111111111111111111100000000 00000000
CSI request field (Note 3)			'10'
PDSCH transmission mode			4
Note 1: $P_B = 1$.			
Note 2: If the UE reports in an available uplink reporting instance at subframe SF#n based on PMI estimation at a downlink SF not later than SF#(n-4), this reported PMI cannot be applied at the eNB downlink before SF#(n+4).			
Note 3: Multiple CC-s under test are configured as the 1 st set of serving cells by higher layers.			
Note 4: ACK/NACK bits are transmitted using PUSCH with PUCCH format 3.			
Note 5: The same PDSCH transmission mode is applied to each component carrier.			

Table 8.2.3.3.1-2: Single carrier performance with different bandwidths for multiple CA configurations for FDD PCell and SCell (FRC)

Band-width	Reference Channel	OCNG Pattern	Propagation Condition	Correlation Matrix and Antenna Configuration	Reference value	
					Fraction of Maximum Throughput (%)	SNR (dB)
1.4 MHz	R.14-4 FDD	OP.1 FDD	EVA5	4x2 Low	70	10.4
3 MHz	R.14-5 FDD	OP.1 FDD	EVA5	4x2 Low	70	9.5
5MHz	R.14-6 FDD	OP.1 FDD	EVA5	4x2 Low	70	9.5
10MHz	R.14 FDD	OP.1 FDD	EVA5	4x2 Low	70	10.1
15MHz	R.14-7 FDD	OP.1 FDD	EVA5	4x2 Low	70	10.1
20MHz	R.14-3 FDD	OP.1 FDD	EVA5	4x2 Low	70	10.3

Table 8.2.3.3.1-3: Single carrier performance with different bandwidths for multiple CA configurations for TDD SCell (FRC)

Band-width	Reference Channel	OCNG Pattern	Propagation Condition	Correlation Matrix and Antenna Configuration	Reference value	
					Fraction of Maximum Throughput (%)	SNR (dB)
1.4 MHz	R.43-1 TDD	OP.1 TDD	EVA5	4x2 Low	70	11.0
3 MHz	R.43-2 TDD	OP.1 TDD	EVA5	4x2 Low	70	9.8
5MHz	R.43-3 TDD	OP.1 TDD	EVA5	4x2 Low	70	10.0
10MHz	R.43-4 TDD	OP.1 TDD	EVA5	4x2 Low	70	10.5
15MHz	R.43-5 TDD	OP.1 TDD	EVA5	4x2 Low	70	10.6
20MHz	R.43 TDD	OP.1 TDD	EVA5	4x2 Low	70	10.7

Table 8.2.3.3.1-4: Minimum performance for multiple CA configurations with 2DL CCs (FRC)

Test number	Aggregated Bandwidth (MHz)			Minimum performance requirement	UE Category
	Total	FDD CC	TDD CC		
1	2x20	20	20	As defined in Table 8.2.3.3.1-2 and Table 8.2.3.3.1-3 per CC	≥5
2	20+10	10	20	As defined in Table 8.2.3.3.1-2 and Table 8.2.3.3.1-3 per CC	≥5
3	20+15	15	20	As defined in Table 8.2.3.3.1-2 and Table 8.2.3.3.1-3 per CC	≥5
Note 1:	The applicability of requirements for different CA configurations and bandwidth combination sets is defined in 8.1.2.3B				

Table 8.2.3.3.1-5: Minimum performance for multiple CA configurations with 3DL CCs (FRC)

Test number	Aggregated Bandwidth (MHz)			Minimum performance requirement	UE Category
	Total	FDD CC	TDD CC		
1	3x20	20	2x20	As defined in Table 8.2.3.3.1-2 and Table 8.2.3.3.1-3 per CC	≥5
2	20+20+15	15	2x20	As defined in Table 8.2.3.3.1-2 and Table 8.2.3.3.1-3 per CC	≥5
3	20+20+10	10	2x20	As defined in Table 8.2.3.3.1-2 and Table 8.2.3.3.1-3 per CC	≥5
Note 1:	The applicability of requirements for different CA configurations and bandwidth combination sets is defined in 8.1.2.3B				

8.2.3.3.2 Minimum Requirement for TDD PCell

For TDD FDD CA with TDD PCell and 2DL CCs, the requirements are specified in Table 8.2.3.3.2-4 based on single carrier requirement specified in Table 8.2.3.3.2-2 and Table 8.2.3.3.2-3, with the addition of the parameters in Table 8.2.3.3.2-1 and the downlink physical channel setup according to Annex C.3.2. The purpose of these tests is to verify the closed loop rank-two performance with wideband and frequency selective precoding.

For TDD FDD CA with TDD PCell and 3DL CCs, the requirements are specified in Table 8.2.3.3.2-5 based on single carrier requirement specified in Table 8.2.3.3.2-2 and Table 8.2.3.3.2-3, with the addition of the parameters in Table 8.2.3.3.2-1 and the downlink physical channel setup according to Annex C.3.2. The purpose of these tests is to verify the closed loop rank-two performance with wideband and frequency selective precoding.

The test coverage for different number of component carriers is defined in 8.1.2.4.

Table 8.2.3.3.2-1: Test Parameters for Multi-Layer Spatial Multiplexing (FRC) for CA

Parameter		Unit	Value
Downlink power allocation	ρ_A	dB	-6
	ρ_B	dB	-6 (Note 1)
	σ	dB	3
N_{oc} at antenna port		dBm/15kHz	-98
Precoding granularity		PRB	Widelband pre-coding for 1.4MHz, 4 for 3MHz and 5MHz CCs, 6 for 10MHz CCs, 8 for 15MHz and 20MHz CCs
PMI delay (Note 2)	FDD CC	ms	8
	TDD CC	ms	10 or 11
Reporting interval	FDD CC	ms	1
	TDD CC	ms	1 or 4 (Note 3)
Reporting mode			PUSCH 1-2
CodeBookSubsetRestriction bitmap			00000000000000000000000000000000 00001111111111111111111100000000 00000000
CSI request field (Note 3)			'10'
PDSCH transmission mode			TM4
<p>Note 1: $P_B = 1$.</p> <p>Note 2: If the UE reports in an available uplink reporting instance at subframe SF#n based on PMI estimation at a downlink SF not later than SF#(n-4), this reported PMI cannot be applied at the eNB downlink before SF#(n+4).</p> <p>Note 3: Multiple CC-s under test are configured as the 1st set of serving cells by higher layers.</p> <p>Note 4: ACK/NACK bits are transmitted using PUSCH with PUCCH format 3.</p> <p>Note 5: The same PDSCH transmission mode is applied to each component carrier.</p>			

Table 8.2.3.3.2-2: Single carrier performance with different bandwidths for multiple CA configurations for FDD SCell (FRC)

Band-width	Reference Channel	OCNG Pattern	Propagation Condition	Correlation Matrix and Antenna Configuration	Reference value	
					Fraction of Maximum Throughput (%)	SNR (dB)
1.4 MHz	R.14-4 FDD	OP.1 FDD	EVA5	4x2 Low	70	10.4
3 MHz	R.14-5 FDD	OP.1 FDD	EVA5	4x2 Low	70	9.5
5MHz	R.14-6 FDD	OP.1 FDD	EVA5	4x2 Low	70	9.5
10MHz	R.14 FDD	OP.1 FDD	EVA5	4x2 Low	70	10.1
15MHz	R.14-7 FDD	OP.1 FDD	EVA5	4x2 Low	70	10.1
20MHz	R.14-3 FDD	OP.1 FDD	EVA5	4x2 Low	70	10.3

Table 8.2.3.3.2-3: Single carrier performance with different bandwidths for multiple CA configurations for TDD PCell and SCell (FRC)

Band-width	Reference Channel	OCNG Pattern	Propagation Condition	Correlation Matrix and Antenna Configuration	Reference value	
					Fraction of Maximum Throughput (%)	SNR (dB)
1.4 MHz	R.43-1 TDD	OP.1 TDD	EVA5	4x2 Low	70	11.0
3 MHz	R.43-2 TDD	OP.1 TDD	EVA5	4x2 Low	70	9.8
5MHz	R.43-3 TDD	OP.1 TDD	EVA5	4x2 Low	70	10.0
10MHz	R.43-4 TDD	OP.1 TDD	EVA5	4x2 Low	70	10.5
15MHz	R.43-5 TDD	OP.1 TDD	EVA5	4x2 Low	70	10.6
20MHz	R.43 TDD	OP.1 TDD	EVA5	4x2 Low	70	10.7

Table 8.2.3.3.2-4: Minimum performance for multiple CA configurations with 2DL CCs (FRC)

Test number	Aggregated Bandwidth (MHz)			Minimum performance requirement	UE Category
	Total	FDD CC	TDD CC		
1	2x20	20	20	As defined in Table 8.2.3.3.2-2 and Table 8.2.3.3.2-3 per CC	≥5
2	20+10	10	20	As defined in Table 8.2.3.3.2-2 and Table 8.2.3.3.2-3 per CC	≥5
3	20+15	15	20	As defined in Table 8.2.3.3.2-2 and Table 8.2.3.3.2-3 per CC	≥5
Note 1:	The applicability of requirements for different CA configurations and bandwidth combination sets is defined in 8.1.2.3B				

Table 8.2.3.3.2-5: Minimum performance for multiple CA configurations with 3DL CCs (FRC)

Test number	Aggregated Bandwidth (MHz)			Minimum performance requirement	UE Category
	Total	FDD CC	TDD CC		
1	3x20	20	2x20	As defined in Table 8.2.3.3.2-2 and Table 8.2.3.3.2-3 per CC	≥5
2	20+20+15	15	2x20	As defined in Table 8.2.3.3.2-2 and Table 8.2.3.3.2-3 per CC	≥5
3	20+20+10	10	2x20	As defined in Table 8.2.3.3.2-2 and Table 8.2.3.3.2-3 per CC	≥5
Note 1:	The applicability of requirements for different CA configurations and bandwidth combination sets is defined in 8.1.2.3B.				

8.3 Demodulation of PDSCH (User-Specific Reference Symbols)

8.3.1 FDD

The parameters specified in Table 8.3.1-1 are valid for FDD unless otherwise stated.

Table 8.3.1-1: Common Test Parameters for User-specific Reference Symbols

Parameter	Unit	Value
Cyclic prefix		Normal
Cell ID		0
Inter-TTI Distance		1
Number of HARQ processes	Processes	8
Maximum number of HARQ transmission		4
Redundancy version coding sequence		{0,1,2,3} for QPSK and 16QAM {0,0,1,2} for 64QAM and 256QAM
Number of OFDM symbols for PDCCH	OFDM symbols	2
Precoder update granularity		Frequency domain: 1 PRG for Transmission modes 9 and 10 Time domain: 1 ms
Note 1: Void.		
Note 2: Void.		

8.3.1.1 Single-layer Spatial Multiplexing

For single-layer transmission on antenna ports 7 or 8 upon detection of a PDCCH with DCI format 2C, the requirements are specified in Table 8.3.1.1-1 and 8.3.1.1-2, with the addition of the parameters in Table 8.3.1.1-3 and the downlink physical channel setup according to Annex C.3.2. The purpose of these tests is to verify rank-1 performance on one of the antenna ports 7 or 8 with and without a simultaneous transmission on the other antenna port, and to verify rate matching with multiple CSI reference symbol configurations with non-zero and zero transmission power.

Table 8.3.1.1-1: Test Parameters for Testing CDM-multiplexed DM RS (single layer) with multiple CSI-RS configurations

parameter		Unit	Test 1	Test 2	Test 3
Downlink power allocation	ρ_A	dB	0	0	0
	ρ_B	dB	0 (Note 1)	0 (Note 1)	0 (Note 1)
	σ	dB	-3	-3	-3
Beamforming model			Annex B.4.1	Annex B.4.1	Annex B.4.1
Cell-specific reference signals			Antenna ports 0,1		
CSI reference signals			Antenna ports 15,...,18	Antenna ports 15,...,18	Antenna ports 15, ..., 18
CSI-RS periodicity and subframe offset $T_{\text{CSI-RS}} / \Delta_{\text{CSI-RS}}$		Subframes	5 / 2	5 / 2	5 / 2
CSI reference signal configuration			0	3	0
Zero-power CSI-RS configuration $I_{\text{CSI-RS}} / \text{ZeroPowerCSI-RS}$ bitmap		Subframes / bitmap	3 / 0001000000000000	3 / 0001000000000000	3 / 0001000000000000
N_{oc} at antenna port		dBm/15kHz	-98	-98	-98
Symbols for unused PRBs			OCNG (Note 4)	OCNG (Note 4)	OCNG (Note 4)
Number of allocated resource blocks (Note 2)		PRB	50	50	50
Simultaneous transmission			No	Yes (Note 3, 5)	No
PDSCH transmission mode			9	9	9
<p>Note 1: $P_B = 1$.</p> <p>Note 2: The modulation symbols of the signal under test are mapped onto antenna port 7 or 8.</p> <p>Note 3: Modulation symbols of an interference signal is mapped onto the antenna port (7 or 8) not used for the input signal under test.</p> <p>Note 4: These physical resource blocks are assigned to an arbitrary number of virtual UEs with one PDSCH per virtual UE; the data transmitted over the OCNG PDSCHs shall be uncorrelated pseudo random data, which is QPSK modulated.</p> <p>Note 5: The two UEs' scrambling identities n_{SCID} are set to 0 for CDM-multiplexed DM RS with interfering simultaneous transmission test cases.</p>					

Table 8.3.1.1-2: Minimum performance for CDM-multiplexed DM RS without simultaneous transmission (FRC) with multiple CSI-RS configurations

Test number	Bandwidth and MCS	Reference Channel	OCNG Pattern	Propagation Condition	Correlation Matrix and Antenna Configuration	Reference value		UE Category	UE DL Category
						Fraction of Maximum Throughput (%)	SNR (dB)		
1	10 MHz QPSK 1/3	R.43 FDD	OP.1 FDD	EVA5	2x2 Low	70	-1	≥1	≥6
3	10MHz 256QAM	R. 66 FDD	OP.1 FDD	EPA5	2x2 Low	70	24.3	11-12	≥11

Table 8.3.1.1-3: Minimum performance for CDM-multiplexed DM RS with interfering simultaneous transmission (FRC) with multiple CSI-RS configurations

Test number	Bandwidth and MCS	Reference Channel	OCNG Pattern	Propagation Condition	Correlation Matrix and Antenna Configuration	Reference value		UE Category
						Fraction of Maximum Throughput (%)	SNR (dB)	
2	10 MHz 64QAM 1/2	R.50 FDD	OP.1 FDD	EPA5	2x2 Low	70	21.9	≥2

Note 1: The reference channel applies to both the input signal under test and the interfering signal.

8.3.1.1A Enhanced Performance Requirement Type A – Single-layer Spatial Multiplexing with TM9 interference model

The requirements are specified in Table 8.3.1.1A-2, with the addition of the parameters in Table 8.3.1.1A-1 and the downlink physical channel setup according to Annex C.3.2. The purpose of these tests is to verify closed loop rank one performance on one of the antenna ports 7 or 8 without a simultaneous transmission on the other antenna port in the serving cell when the PDSCH transmission in the serving cell is interfered by PDSCH of one dominant interfering cell applying transmission mode 9 interference model defined in clause B.5.4. In 8.3.1.1A-1, Cell 1 is the serving cell, and Cell 2 is the interfering cell. The downlink physical channel setup is according to Annex C.3.2 for each of Cell 1 and Cell 2, respectively.

Table 8.3.1.1A-1: Test Parameters for Testing CDM-multiplexed DM RS (single layer) with TM9 interference model

parameter		Unit	Cell 1	Cell 2
Downlink power allocation	ρ_A	dB	0	0
	ρ_B	dB	0 (Note 1)	0
	σ	dB	-3	-3
Cell-specific reference signals			Antenna ports 0,1	Antenna ports 0,1
CSI reference signals			Antenna ports 15,...,18	N/A
CSI-RS periodicity and subframe offset $T_{\text{CSI-RS}} / \Delta_{\text{CSI-RS}}$		Subframes	5 / 2	N/A
CSI reference signal configuration			0	N/A
N_{oc} at antenna port		dBm/15kHz	-98	N/A
DIP (Note 2)		dB	N/A	-1.73
BW_{Channel}		MHz	10	10
Cyclic Prefix			Normal	Normal
Cell Id			0	126
Number of control OFDM symbols			2	2
PDSCH transmission mode			9	N/A
Beamforming model			As specified in clause B.4.3 (Note 4, 5)	N/A
Interference model			N/A	As specified in clause B.5.4
Probability of occurrence of transmission rank in interfering cells	Rank 1		N/A	70
	Rank 2		N/A	30
Precoder update granularity		PRB	50	6
PMI delay (Note 5)		Ms	8	N/A
Reporting interval		Ms	5	N/A
Reporting mode			PUCCH 1-1	N/A
CodeBookSubsetRestriction bitmap			0000000000000000 0000000000000000 0000000000000000 1111111111111111	N/A
Symbols for unused PRBs			OCNG (Note 6)	N/A
Simultaneous transmission			No simultaneous transmission on the other antenna port in (7 or 8) not used for the input signal under test	N/A
Physical channel for CQI reporting			PUSCH(Note 8)	N/A
cqi-pmi-ConfigurationIndex			5	N/A
Note 1: $P_B = 1$ Note 2: The respective received power spectral density of each interfering cell relative to N_{oc} is defined by its associated DIP value as specified in clause B.5.1. Note 3: The modulation symbols of the signal under test in Cell 1 are mapped onto antenna port 7 or 8.				

Note 4:	The precoder in clause B.4.3 follows UE recommended PMI.
Note 5:	If the UE reports in an available uplink reporting instance at subframe SF#n based on PMI estimation at a downlink SF not later than SF#(n-4), this reported PMI cannot be applied at the eNB downlink before SF#(n+4).
Note 6:	These physical resource blocks are assigned to an arbitrary number of virtual UEs with one PDSCH per virtual UE; the data transmitted over the OCNG PDSCHs shall be uncorrelated pseudo random data, which is QPSK modulated.
Note 7:	All cells are time-synchronous.
Note 8:	To avoid collisions between CQI reports and HARQ-ACK it is necessary to report both on PUSCH instead of PUCCH. PDCCH DCI format 0 shall be transmitted in downlink SF#4 and #9 to allow periodic CQI to multiplex with the HARQ-ACK on PUSCH in uplink subframe SF#8 and #3.

Table 8.3.1.1A-2: Enhanced Performance Requirement Type A, CDM-multiplexed DM RS with TM9 interference model

Test Number	Reference Channel	OCNG Pattern		Propagation Conditions		Correlation Matrix and Antenna Configuration (Note 3)	Reference Value		UE Category
		Cell 1	Cell 2	Cell 1	Cell 2		Fraction of Maximum Throughput (%)	SINR (dB) (Note 2)	
1	R.48 FDD	OP.1 FDD	N/A	EVA5	EVA5	4x2 Low	70	-1.1	≥1
Note 1: The propagation conditions for Cell 1 and Cell 2 are statistically independent. Note 2: SINR corresponds to \hat{E}_s / N_{oc} of Cell 1 as defined in clause 8.1.1. Note 3: Correlation matrix and antenna configuration parameters apply for each of Cell 1 and Cell 2.									

8.3.1.1B Single-layer Spatial Multiplexing (demodulation subframe overlaps with aggressor cell ABS and CRS assistance information are configured)

The requirements are specified in Table 8.3.1.1B -2, with the addition of parameters in Table 8.3.1.1B-1. The purpose is to verify the performance of the antenna ports 7 or 8 without a simultaneous transmission on the other antenna port in the serving cell if the PDSCH transmission in the serving cell takes place in subframes that overlap with ABS [9] of the aggressor cell with CRS assistance information. In Table 8.3.1.1B-1, Cell 1 is the serving cell, and Cell 2 and Cell 3 are the aggressor cells. The downlink physical channel setup for Cell 1 is according to Annex C.3.2 and for Cell 2 and Cell 3 is according to Annex C.3.3, respectively. The CRS assistance information [7] includes Cell 2 and Cell 3.

Table 8.3.1.1B-1: Test parameters of TM9-Single-Layer (2 CSI-RS ports) – Non-MBSFN ABS

Parameter		Unit	Cell 1	Cell 2	Cell 3
Downlink power allocation	ρ_A	dB	0	-3	-3
	ρ_B	dB	0 (Note 1)	-3 (Note 1)	-3 (Note 1)
	σ	dB	-3	N/A	N/A
N_{oc} at antenna port	N_{oc1}	dBm/15kHz	-98 (Note 2)	N/A	N/A
	N_{oc2}	dBm/15kHz	-98 (Note 3)	N/A	N/A
	N_{oc3}	dBm/15kHz	-93 (Note 4)	N/A	N/A
\hat{E}_s / N_{oc2}		dB	Reference Value in Table 8.3.1.1B-2	12	10
BW _{Channel}		MHz	10	10	10
Subframe Configuration			Non-MBSFN	Non-MBSFN	Non-MBSFN
Time Offset between Cells		μs	N/A	3	-1
Frequency shift between Cells		Hz	N/A	300	-100
Cell Id			0	1	126
Cell-specific reference signals			Antenna ports 0,1		
CSI reference signals			Antenna ports 15,16	N/A	N/A
CSI-RS periodicity and subframe offset $T_{CSI-RS} / \Delta_{CSI-RS}$		Subframes	5 / 2	N/A	N/A
CSI reference signal configuration			8	N/A	N/A
Zero-power CSI-RS configuration $I_{CSI-RS} / \text{ZeroPowerCSI-RS bitmap}$		Subframes / bitmap	3 / 00100000000000 00	N/A	N/A
ABS pattern (Note 5)			N/A	11000000 11000000 11000000 11000000 11000000	11000000 11000000 11000000 11000000 11000000
RLM/RRM Measurement Subframe Pattern (Note 6)			10000000 10000000 10000000 10000000 10000000	N/A	N/A
CSI Subframe Sets (Note7)	$C_{CSI,0}$		11000000 11000000 11000000 11000000 11000000	N/A	N/A
	$C_{CSI,1}$		00111111 00111111 00111111 00111111 00111111	N/A	N/A
Number of control OFDM symbols			2	Note 8	Note 8
PDSCH transmission mode			TM9-1layer	Note 9	Note 9
Precoding granularity			Frequency domain: 1 PRG Time domain: 1 ms	N/A	N/A
Beamforming model			Annex B.4.1	N/A	N/A
Cyclic prefix			Normal	Normal	Normal

- Note 1: $P_B = 1$.
- Note 2: This noise is applied in OFDM symbols #1, #2, #3, #5, #6, #8, #9, #10, #12, #13 of a subframe overlapping with the aggressor ABS.
- Note 3: This noise is applied in OFDM symbols #0, #4, #7, #11 of a subframe overlapping with the aggressor ABS.
- Note 4: This noise is applied in all OFDM symbols of a subframe overlapping with aggressor non-ABS
- Note 5: ABS pattern as defined in [9]. PDSCH other than SIB1/paging and its associated PDCCH/PCFICH are transmitted in the serving cell subframe when the subframe is overlapped with the ABS subframe of aggressor cell and the subframe is available in the definition of the reference channel.
- Note 6: Time-domain measurement resource restriction pattern for PCell measurements as defined in [7]
- Note 7: As configured according to the time-domain measurement resource restriction pattern for CSI measurements defined in [7].
- Note 8: The number of control OFDM symbols is not available for ABS and is 2 for the subframe indicated by "0" of ABS pattern.
- Note 9: Downlink physical channel setup in Cell 2 and Cell 3 in accordance with Annex C.3.3 applying OCNNG pattern as defined in Annex A.5.
- Note 10: If the UE reports in an available uplink reporting instance at subframe SF#n based on PMI estimation at a downlink SF not later than SF#(n-4), this reported PMI cannot be applied at the eNB downlink before SF#(n+4).
- Note 11: The number of the CRS ports in Cell 1, Cell 2 and Cell 3 is the same.
- Note 12: SIB-1 will not be transmitted in Cell 2 and Cell 3 in this test.
- Note 13: The modulation symbols of the signal under test are mapped onto antenna port 7 or 8.

Table 8.3.1.1B-2: Minimum Performance of TM9-Single-Layer (2 CSI-RS ports) – Non-MBSFN ABS

Test Number	Reference Channel	OCNG Pattern			Propagation Conditions (Note1)			Correlation Matrix and Antenna Configuration (Note 2)	Reference Value		UE Category
		Cell 1	Cell 2	Cell 3	Cell 1	Cell 2	Cell 3		Fraction of Maximum Throughput (%)	SNR (dB) (Note 3)	
1	R.51 FDD	OP.1 FDD	OP.1 FDD	OP.1 FDD	EVA5			2x2 Low	70	7.8	≥2
Note 1: The propagation conditions for Cell 1, Cell 2 and Cell 3 are statistically independent. Note 2: The correlation matrix and antenna configuration apply for Cell 1, Cell 2 and Cell 3. Note 3: SNR corresponds to \hat{E}_s / N_{oc2} of cell 1.											

8.3.1.1C Enhanced Performance Requirement Type B – Single-layer Spatial Multiplexing with TM9 interference model

The requirements are specified in Table 8.3.1.1C-2, with the addition of the parameters in Table 8.3.1.1C-1 and the downlink physical channel setup according to Annex C.3.2. The purpose of these tests is to verify closed loop rank one performance on one of the antenna ports 7, 8 without a simultaneous transmission on the other antenna port in the serving cell when the PDSCH transmission in the serving cell is interfered by PDSCH of two interfering cells applying transmission mode 9 interference model defined in clause B.6.4. In 8.3.1.1C-1, Cell 1 is the serving cell, and Cell 2, 3 are interfering cells. The downlink physical channel setup is according to Annex C.3.2 for each of Cell 1, Cell 2 and Cell 3, respectively.

Table 8.3.1.1C-1: Test Parameters for Testing CDM-multiplexed DM RS (Single-layer) with TM9 interference model

Parameter		Unit	Cell 1	Cell 2	Cell 3
Downlink power allocation	ρ_A	dB	0	0	0
	ρ_B	dB	0 (NOTE 1)	0	0
	σ	dB	-3	-3	-3
Cell-specific reference signals			Antenna ports 0,1	Antenna ports 0,1	Antenna ports 0,1
N_{oc} at antenna port		dBm/15kHz	-98		
\bar{E}_s/N_{oc}		dB	N/A	13.91	3.34
$BW_{Channel}$		MHz	10	10	10
Cyclic Prefix			Normal	Normal	Normal
Cell Id			0	1	6
Number of control OFDM symbols			3	3	3
CFI indicated in PCFICH			3	3	3
PDSCH transmission mode			9	9	9
Interference model			N/A	As specified in clause B.6.4	As specified in clause B.6.4
Precoding			Random wideband precoding per TTI	As specified in clause B.6.4	As specified in clause B.6.4
CSI reference signals			Antenna ports 15, 16, 17, 18	Antenna ports 15, 16	Antenna ports 15, 16
CSI-RS periodicity and subframe offset $T_{CSI-RS} / \Delta_{CSI-RS}$		Subframes	10 / 1	10 / 1	10 / 1
CSI reference signal configuration			5	6	7
Zero-power CSI-RS configuration $l_{CSI-RS} / ZeroPowerCSI-RS$ bitmap		Subframes / bitmap	6 / 10000000000000000000	6 / 0100000000000000	6 / 0010000000000000
Time offset to cell 1		us	N/A	2	3
Frequency offset to cell 1		Hz	N/A	200	300
MBSFN			Not configured	Not configured	Not configured
NeighCellsInfo-r12 (NOTE 4)	p-aList-r12		N/A	{dB-6, dB-3, dB0}	{dB-6, dB-3, dB0}
	transmissionModelList-r12		N/A	{2,3,4,8,9}	{2,3,4,8,9}
NOTE 1: $P_B = 1$					
NOTE 2: Cell 1 is the serving cell. Cell 2, 3 are the interfering cells.					
NOTE 3: CSI-RS configurations are according to [4] subclause 6.10.5.2.					
NOTE 4: NeighCellsInfo-r12 is described in subclause 6.3.2 of [7].					

Table 8.3.1.1C-2: Minimum Performance for Enhanced Performance Requirement Type B, CDM-multiplexed DM RS with TM9 interference model

Test Number	Reference Channel	OCNG Pattern			Propagation Conditions			Correlation Matrix and Antenna Configuration			Reference Value		UE Category
		Cell 1	Cell 2	Cell 3	Cell 1	Cell 2	Cell 3	Cell 1	Cell 2	Cell 3	Fraction of Maximum Throughput (%)	SNR (dB) (NOTE 2)	
1	R.69 FDD	OP. 1 FDD	N/A	N/A	EP A5	EP A5	EP A5	4x2 Low	2x2 Low	2x2 Low	85	18.5	≥1

NOTE 1: The propagation conditions for Cell 1, Cell 2 and Cell 3 are statistically independent.

NOTE 2: SNR corresponds to \bar{E}_s/N_{oc} of Cell 1 as defined in clause 8.1.1.

8.3.1.1D Enhanced Performance Requirement Type B – Single-layer Spatial Multiplexing with CRS interference model

The requirements are specified in Table 8.3.1.1D-2, with the addition of the parameters in Table 8.3.1.1D-1 and the downlink physical channel setup according to Annex C.3.2. The purpose of these tests is to verify closed loop rank one performance on one of the antenna ports 7 or 8 without a simultaneous transmission on the other antenna port in the serving cell when the PDSCH transmission in the serving cell is interfered by the CRS of the interfering cell, applying the CRS interference model defined in clause B.6.5. In 8.3.1.1D-1, Cell 1 is the serving cell, and Cell 2, 3 are interfering cells. The downlink physical channel setup is according to Annex C.3.2 for each of Cell 1, Cell 2 and Cell 3, respectively.

Table 8.3.1.1D-1: Test Parameters for Testing CDM-multiplexed DM RS (Single-layer) with CRS interference model

Parameter		Unit	Cell 1	Cell 2	Cell 3
Downlink power allocation	ρ_A	dB	0	0	0
	ρ_B	dB	0 (NOTE 1)	0	0
	σ	dB	-3	-3	-3
Cell-specific reference signals			Antenna ports 0,1	Antenna ports 0,1	Antenna ports 0,1
N_{oc} at antenna port		dBm/15kHz	-98		
\widehat{E}_s/N_{oc}		dB	N/A	13.91	3.34
$BW_{Channel}$		MHz	10	10	10
Cyclic Prefix			Normal	Normal	Normal
Cell Id			0	1	6
Number of control OFDM symbols			3	3	3
CFI indicated in PCFICH			3	3	3
PDSCH transmission mode			8	N/A	N/A
Interference model			N/A	As specified in clause B.6.5	As specified in clause B.6.5
Precoding			Random wideband precoding per TTI	N/A	N/A
Time offset to cell 1		us	N/A	2	3
Frequency offset to cell 1		Hz	N/A	200	300
MBSFN			Not configured	Not configured	Not configured
NeighCellsInfo-r12 (NOTE 3)	p-aList-r12		N/A	{dB-6, dB-3, dB0}	{dB-6, dB-3, dB0}
	transmissionModeList-r12		N/A	{2,3,4,8,9}	{2,3,4,8,9}
NOTE 1: $P_B = 1$					
NOTE 2: Cell 1 is the serving cell. Cell 2, 3 are the interfering cells.					
NOTE 3: NeighCellsInfo-r12 is described in subclause 6.3.2 of [7].					

Table 8.3.1.1D-2: Minimum Performance for Enhanced Performance Requirement Type B, CDM-multiplexed DM RS with CRS interference model

Test Number	Reference Channel	OCNG Pattern			Propagation Conditions			Correlation Matrix and Antenna Configuration (NOTE 3)	Reference Value		UE Category
		Cell 1	Cell 2	Cell 3	Cell 1	Cell 2	Cell 3		Fraction of Maximum Throughput (%)	SNR (dB) (NOTE 2)	
1	R.71 FDD	OP. 1 FDD	N/A	N/A	EP A5	EP A5	EP A5	2x2 Low	85	14.3	≥2

NOTE 1: The propagation conditions for Cell 1, Cell 2 and Cell 3 are statistically independent.

NOTE 2: SNR corresponds to \hat{E}_s/N_{oc} of Cell 1 as defined in clause 8.1.1.

NOTE 3: Correlation matrix and antenna configuration parameters apply for each of Cell 1, Cell 2 and Cell 3.

8.3.1.1E Enhanced Performance Requirement Type B – Single-layer Spatial Multiplexing with TM3 interference model

The requirements are specified in Table 8.3.1.1E-2, with the addition of the parameters in Table 8.3.1.1E-1 and the downlink physical channel setup according to Annex C.3.2. The purpose of these tests is to verify closed loop rank one performance on one of the antenna ports 7 or 8 without a simultaneous transmission on the other antenna port in the serving cell when the PDSCH transmission in the serving cell is interfered by PDSCH of two interfering cells applying transmission mode 3 interference model defined in clause B.6.2. In 8.3.1.1E-1, Cell 1 is the serving cell, and Cell 2, 3 are interfering cells. The downlink physical channel setup is according to Annex C.3.2 for each of Cell 1, Cell 2 and Cell 3, respectively.

Table 8.3.1.1E-1: Test Parameters for Testing CDM-multiplexed DM RS (Single-layer) with TM3 interference model

Parameter		Unit	Cell 1	Cell 2	Cell 3
Downlink power allocation	ρ_A	dB	0	-3	-3
	ρ_B	dB	0 (NOTE 1)	-3	-3
	σ	dB	-3	0	0
Cell-specific reference signals			Antenna ports 0,1	Antenna ports 0,1	Antenna ports 0,1
N_{oc} at antenna port		dBm/15kHz	-98		
\bar{E}_s/N_{oc}		dB	N/A	3.28	0.74
$BW_{Channel}$		MHz	10	10	10
Cyclic Prefix			Normal	Normal	Normal
Cell Id			0	1	6
Number of control OFDM symbols			3	3	3
CFI indicated in PCFICH			3	Random from {1,2,3}	Random from {1,2,3}
PDSCH transmission mode			8	3	3
Interference model			N/A	As specified in clause B.6.2	As specified in clause B.6.2
Precoding			Random wideband precoding per TTI	As specified in clause B.6.2	As specified in clause B.6.2
Time offset to cell 1		us	N/A	2	3
Frequency offset to cell 1		Hz	N/A	200	300
MBSFN			Not configured	Not configured	Not configured
NeighCellsInfo-r12 (NOTE 4)	p-aList-r12		N/A	{dB-6, dB-3, dB0}	{dB-6, dB-3, dB0}
	transmissionModeList-r12		N/A	{2,3,4,8,9}	{2,3,4,8,9}
NOTE 1: $P_B = 1$					
NOTE 2: Cell 1 is the serving cell. Cell 2, 3 are the interfering cells.					
NOTE 3: CSI-RS configurations are according to [4] subclause 6.10.5.2.					
NOTE 4: NeighCellsInfo-r12 is described in subclause 6.3.2 of [7].					

Table 8.3.1.1E-2: Minimum Performance for Enhanced Performance Requirement Type B, CDM-multiplexed DM RS with TM3 interference model

Test Number	Reference Channel	OCNG Pattern			Propagation Conditions			Correlation Matrix and Antenna Configuration (NOTE 3)	Reference Value		UE Category
		Cell 1	Cell 2	Cell 3	Cell 1	Cell 2	Cell 3		Fraction of Maximum Throughput (%)	SNR (dB) (NOTE 2)	
1	R.70 FDD	OP. 1 FD D	N/A	N/A	EP A5	EP A5	EP A5	2x2 Low	85	11.5	≥ 1
NOTE 1: The propagation conditions for Cell 1, Cell 2 and Cell 3 are statistically independent.											
NOTE 2: SNR corresponds to \bar{E}_s/N_{oc} of Cell 1 as defined in clause 8.1.1.											
NOTE 3: Correlation matrix and antenna configuration parameters apply for each of Cell 1, Cell 2 and Cell 3.											

8.3.1.1F Enhanced Performance Requirement Type B – Single-layer Spatial Multiplexing with TM10 serving cell configuration and TM9 interference model

The requirements are specified in Table 8.3.1.1F-2, with the addition of the parameters in Table 8.3.1.1F-1 and the downlink physical channel setup according to Annex C.3.2. The purpose of these tests is to verify closed loop rank one performance on one of the antenna ports 7 or 8 without a simultaneous transmission on the other antenna port in the

servicing cell when the PDSCH transmission configured with TM10 in the servicing cell is interfered by PDSCH of one dominant interfering cell applying transmission mode 9 interference model defined in clause B.6.3. The NAICS network assistance is provided when the servicing cell TM10 is configured with QCL-type A and PCID based DM-RS scrambling. The neighbouring cell has transmission mode TM9 and NeighCellsInfo-r12 for interfering cell indicates presence of TM9. In 8.3.1.1F-1, Cell 1 is the servicing cell, and Cell 2, 3 are interfering cells. The downlink physical channel setup is according to Annex C.3.2 for each of Cell 1, Cell 2 and Cell 3, respectively.

Table 8.3.1.1F-1: Test Parameters for Testing CDM-multiplexed DM RS (single layer) with TM10 servicing cell configuration and TM9 interference model

Parameter		Unit	Cell 1	Cell 2	Cell 3
Downlink power allocation	ρ_A	dB	0	0	0
	ρ_B	dB	0 (Note 1)	0	0
	σ	dB	-3	-3	-3
Cell-specific reference signals			Antenna ports 0,1	Antenna ports 0,1	Antenna ports 0,1
N_{oc} at antenna port		dBm/15kHz	-98		
\widehat{E}_s / N_{oc}		dB	N/A	13.91	3.34
BW _{Channel}		MHz	10	10	10
Cyclic Prefix			Normal	Normal	Normal
Cell Id			0	1	6
Number of control OFDM symbols			3	3	3
CFI indicated in PCFICH			3	3	3
PDSCH transmission mode			10	9	9
Interference model			N/A	As specified in clause B.6.4	As specified in clause B.6.4
Precoding			Random wideband precoding per TTI	As specified in clause B.6.4	As specified in clause B.6.4
CSI reference signals			Antenna ports 15, 16, 17, 18	Antenna ports 15, 16	Antenna ports 15, 16
CSI-RS periodicity and subframe offset $T_{CSI-RS} / \Delta_{CSI-RS}$		Subframes	10 / 1	10 / 1	10 / 1
CSI reference signal configuration			5	6	7
Zero-power CSI-RS configuration $I_{CSI-RS} / \text{ZeroPowerCSI-RS}$ bitmap		Subframes / bitmap	6 / 1000000000 00000	6 / 01000000000 0000	6 / 00100000000 00000
Time offset to cell 1		us	N/A	2	3
Frequency offset to cell 1		Hz	N/A	200	300
MBSFN			Not configured	Not configured	Not configured
NeighCellsInfo- r12 (Note 4)	p-aList-r12		N/A	{dB-6, dB-3, dB0}	{dB-6, dB-3, dB0}
	transmissionModeList- r12		N/A	{2,3,4,8,9}	{2,3,4,8,9}
Note 1: $P_B = 1$					
Note 2: Cell 1 is the servicing cell. Cell 2, 3 are the interfering cells.					
Note 3: CSI-RS configurations are according to [4] subclause 6.10.5.2.					
Note 4: NeighCellsInfo-r12 is described in subclause 6.3.2 of [7].					

Table 8.3.1.1F-2: Minimum Performance for Enhanced Performance Requirement Type B, CDM-multiplexed DM RS with TM10 serving cell configuration and TM9 interference model

Test Number	Reference Channel	OCNG Pattern			Propagation Conditions			Correlation Matrix and Antenna Configuration			Reference Value		UE Category
		Cell 1	Cell 2	Cell 3	Cell 1	Cell 2	Cell 3	Cell 1	Cell 2	Cell 3	Fraction of Maximum Throughput (%)	SNR (dB) (Note 2)	
1	R.69 FDD	OP. 1 FDD	N/A	N/A	EP A5	EP A5	EP A5	4x2 Low	2x2 Low	2x2 Low	85	18.2	≥1

Note 1: The propagation conditions for Cell 1, Cell 2 and Cell 3 are statistically independent.

Note 2: SINR corresponds to \hat{E}_s/N_{oc} of Cell 1 as defined in clause 8.1.1.

8.3.1.2 Dual-Layer Spatial Multiplexing

For dual-layer transmission on antenna ports 7 and 8 upon detection of a PDCCH with DCI format 2C, the requirements are specified in Table 8.3.1.2-2, with the addition of the parameters in Table 8.3.1.2-1 where Cell 1 is the serving cell and Cell 2 is the interfering cell. The downlink physical channel setup is set according to Annex C.3.2. The purpose of these tests is to verify the rank-2 performance for full RB allocation, to verify rate matching with multiple CSI reference symbol configurations with non-zero and zero transmission power, and to verify that the UE correctly estimate SNR.

Table 8.3.1.2-1: Test Parameters for Testing CDM-multiplexed DM RS (dual layer) with multiple CSI-RS configurations

Parameter	Unit	Test 1		
		Cell 1	Cell 2	
Downlink power allocation	ρ_A	dB	0	0
	ρ_B	dB	0 (Note 1)	0
	σ	dB	-3	-3
	PDSCH_RA	dB	4	N/A
	PDSCH_RB	dB	4	N/A

Cell-specific reference signals		Antenna ports 0 and 1	Antenna ports 0 and 1
Cell ID		0	126
CSI reference signals		Antenna ports 15,16	NA
Beamforming model		Annex B.4.2	NA
CSI-RS periodicity and subframe offset $T_{CSI-RS} / \Delta_{CSI-RS}$	Subframes	5 / 2	NA
CSI reference signal configuration		8	NA
Zero-power CSI-RS configuration $I_{CSI-RS} / \text{ZeroPowerCSI-RS bitmap}$	Subframes / bitmap	3 / 0010000000000000	NA
N_{oc} at antenna port	dBm/15kHz	-98	-98
\hat{E}_s / N_{oc}		Reference Value in Table 8.3.1.2-2	7.25dB
Symbols for unused PRBs		OCNG (Note 2)	NA
Number of allocated resource blocks (Note 2)	PRB	50	NA
Simultaneous transmission		No	NA
PDSCH transmission mode		9	Blanked
Note 1: $P_B = 1$ Note 2: These physical resource blocks are assigned to an arbitrary number of virtual UEs with one PDSCH per virtual UE; the data transmitted over the OCNG PDSCHs shall be uncorrelated pseudo random data, which is QPSK modulated.			

Table 8.3.1.2-2: Minimum performance for CDM-multiplexed DM RS (FRC) with multiple CSI-RS configurations

Test number	Bandwidth and MCS	Reference Channel	OCNG Pattern		Propagation Condition		Correlation Matrix and Antenna Configuration	Reference value		UE Category
			Cell1	Cell 2	Cell 1	Cell 2		Fraction of Maximum Throughput (%)	SNR (dB)	
1	10 MHz 16QAM 1/2	R.51 FDD	OP.1 FDD	N/A	ETU5	ETU5	2x2 Low	70	14.2	≥ 2
Note 1: The propagation conditions for Cell 1 and Cell 2 are statistically independent. Note 2: Correlation matrix and antenna configuration parameters apply for each of Cell 1 and Cell 2. Note 3: SNR corresponds to \hat{E}_s / N_{oc} of Cell 1.										

8.3.1.2A Enhanced Performance Requirement Type C - Dual-Layer Spatial Multiplexing

The requirements are specified in Table 8.3.1.2A-2, with the addition of the parameters in Table 8.3.1.2A-1 and the downlink physical channel setup according to Annex C.3.2. The purpose of this test is to verify rank two performance for full RB allocation upon antenna ports 7 and 8.

Table 8.3.1.2A-1: Test Parameters for Testing CDM-multiplexed DM RS (dual layer) with multiple CSI-RS configurations

parameter	Unit	Test 1	
Downlink power allocation	ρ_A	dB	0
	ρ_B	dB	0 (Note 1)
	σ	dB	-3
Cell-specific reference signals		Antenna ports 0 and 1	
CSI reference signals		Antenna ports 15,16	
Beamforming model		Annex B.4.2	
CSI-RS periodicity and subframe offset $T_{\text{CSI-RS}} / \Delta_{\text{CSI-RS}}$	Subframes	5 / 2	
CSI reference signal configuration		8	
Zero-power CSI-RS configuration $l_{\text{CSI-RS}} / \text{ZeroPowerCSI-RS}$ bitmap	Subframes / bitmap	3 / 0010000000000000	
N_{oc} at antenna port	dBm/15kHz	-98	
Symbols for unused PRBs		OCNG (Note 2)	
Number of allocated resource blocks (Note 2)	PRB	50	
Simultaneous transmission		No	
PDSCH transmission mode		9	
Note 1: $P_B = 1$ Note 2: These physical resource blocks are assigned to an arbitrary number of virtual UEs with one PDSCH per virtual UE; the data transmitted over the OCNG PDSCHs shall be uncorrelated pseudo random data, which is QPSK modulated.			

Table 8.3.1.2A-2: Enhanced Performance Requirement Type C for CDM-multiplexed DM RS (FRC) with multiple CSI-RS configurations

Test number	Bandwidth and MCS	Reference Channel	OCNG Pattern	Propagation Condition	Correlation Matrix and Antenna Configuration	Reference value		UE Category
						Fraction of Maximum Throughput (%)	SNR (dB)	
1	10 MHz 16QAM 1/2	R.51 FDD	OP.1 FDD	EPA5	2x2 Medium	70	17.4	≥2

8.3.1.3 Performance requirements for DCI format 2D and non Quasi Co-located Antenna Ports

8.3.1.3.1 Minimum requirement with Same Cell ID (with single NZP CSI-RS resource)

The requirements are specified in Table 8.3.1.3.1-3, with the additional parameters in Table 8.3.1.3.1-1 and Table 8.3.1.3.1-2. The purpose of this test is to verify the UE capability of supporting non quasi-co-located antenna ports when the UE receives DCI format 2D in a scenario where the two transmission point share the same Cell ID. In particular the test verifies that the UE, configured with quasi co-location type B, performs correct tracking and compensation of the timing difference between two transmission points, channel parameters estimation and rate matching according to the

‘PDSCH RE Mapping and Quasi-Co-Location Indicator’ (PQI) signalling defined in [6], configured according to Table 8.3.1.3.1-2. In Tables 8.3.1.3.1-1 and 8.3.1.3.1-2, transmission point 1 (TP 1) is the serving cell and transmission point 2 (TP 2) transmits PDSCH. The downlink physical channel setup for TP 1 is according to Table C.3.4-1 and for TP 2 according to Table C.3.4-2.

Table 8.3.1.3.1-1: Test Parameters for quasi co-location type B: same Cell ID

Parameter		Unit	TP 1	TP 2
Downlink power allocation	ρ_A	dB	0	0
	ρ_B	dB	0 (Note 1)	0
	σ	dB	-3	-3
Cell-specific reference signals			Antenna ports 0,1	(Note 2)
CSI-RS 0 antenna ports			NA	Port {15,16}
<i>qcl-CSI-RS-ConfigNZPId-r11</i> , CSI-RS 0 periodicity and subframe offset $T_{CSI-RS} / \Delta_{CSI-RS}$		Subframes	NA	5/2
<i>qcl-CSI-RS-ConfigNZPId-r11</i> , CSI-RS 0 configuration			NA	8
<i>csi-RS-ConfigZPId-r11</i> , Zero-power CSI-RS 0 configuration $I_{CSI-RS} / ZeroPower\ CSI-RS\ bitmap$			NA	2/ 0000010000000000
N_{oc} at antenna port		dBm/15kHz	-98	-98
\hat{E}_s / N_{oc}		dB	Reference point in Table 8.3.1.3.1-3	Reference point in Table 8.3.1.3.1-3
BW _{Channel}		MHz	10	10
Cyclic Prefix			Normal	Normal
Cell Id			0	0
Number of control OFDM symbols			2	2
PDSCH transmission mode			Blanked	10
Number of allocated PRB		PRB	NA	50
<i>qcl-Operation</i> , ‘PDSCH RE Mapping and Quasi-Co-Location Indicator’			Type B, ‘00’	
Time offset between TPs		µs	NA	Reference point in Table 8.3.1.3.1-3
Frequency error between TPs		Hz	NA	0
Beamforming model			NA	Port 7 as specified in clause B.4.1
Symbols for unused PRBs			NA	OCNG (Note 3)
Note 1: $P_B = 1$ Note 2: REs for antenna ports 0 and 1 have zero transmission power. Note 3: These physical resource blocks are assigned to an arbitrary number of virtual UEs with one PDSCH per virtual UE; the data transmitted over the OCNG PDSCHs shall be uncorrelated pseudo random data, which is QPSK modulated.				

Table 8.3.1.3.1-2: Configurations of PQI and DL transmission hypothesis for each PQI set

PQI set index	Parameters in each PQI set		DL transmission hypothesis for each PQI Set	
	NZP CSI-RS Index (For quasi	ZP CSI-RS configuration	TP 1	TP 2

	co-location)			
PQI set 0	CSI-RS 0	ZP CSI-RS 0	Blanked	PDSCH

Table 8.3.1.3.1-3: Minimum performance for quasi co-location type B: same Cell ID

Test Number	Reference Channel	OGCN pattern		Time offset between TPs (μ s)	Propagation Conditions (Note1)		Correlation Matrix and Antenna Configuration (Note 2)	Reference Value		UE Category
		TP 1	TP 2		TP 1	TP 2		Fraction of Maximum Throughput (%)	SNR (dB) (Note 3)	
1	R.52 FDD	NA	OP.1 FDD	2	EPA5	EPA5	2x2 Low	70	12.1	≥ 2
2	R.52 FDD	NA	OP.1 FDD	-0.5	EPA5	EPA5	2x2 Low	70	12.6	≥ 2

Note 1: The propagation conditions for TP 1 and TP 2 are statistically independent.
Note 2: The correlation matrix and antenna configuration apply for TP 1 and TP 2.
Note 3: SNR corresponds to \hat{E}_s / N_{oc} of TP 2 as defined in clause 8.1.1.

8.3.1.3.2 Minimum requirements with Same Cell ID (with multiple NZP CSI-RS resources)

The requirements are specified in Table 8.3.1.3.2-3, with the additional parameters in Tables 8.3.1.3.2-1 and 8.3.1.3.2-2. The purpose of this test is to verify the UE capability of supporting non quasi-co-located antenna ports when the UE receives DCI format 2D in a scenario where the two transmission point share the same Cell ID. In particular the test verifies that the UE, configured with quasi co-location type B, performs correct tracking and compensation of the timing difference between two transmission points, channel parameters estimation and rate matching according to the ‘PDSCH RE Mapping and Quasi-Co-Location Indicator’ (PQI) signalling defined in [6]. In Tables 8.3.1.3.2-1 and 8.3.1.3.2-2, transmission point 1 (TP 1) is the serving cell transmitting PDCCH, synchronization signals and PBCH, and transmission point 2 (TP 2) has same Cell ID as TP 1. Multiple NZP CSI-RS resources and ZP CSI-RS resources are configured. In each sub-frame, DL PDSCH transmission is dynamically switched between 2 TPs with multiple PDSCH RE Mapping and Quasi-Co-Location Indicator configuration (PQI). Configurations of PDSCH RE Mapping and Quasi-Co-Location Indicator and downlink transmission hypothesis are defined in Table 8.3.1.3.2-2. The downlink physical channel setup for TP 1 is according to Table C.3.4-1 and for TP 2 according to Table C.3.4-2.

Table 8.3.1.3.2-1: Test Parameters for timing offset compensation with DPS transmission

parameter	Unit	TP 1	TP 2
Downlink power allocation	ρ_A	dB	0
	ρ_B	dB	0 (Note 1)
	σ	dB	-3

Beamforming model		As specified in clause B.4.1	As specified in clause B.4.1
Cell-specific reference signals		Antenna ports 0,1	(Note 2)
CSI reference signals 0		Antenna ports {15,16}	N/A
CSI-RS 0 periodicity and subframe offset $T_{\text{CSI-RS}} / \Delta_{\text{CSI-RS}}$	Subframes	5 / 2	N/A
CSI reference signal 0 configuration		0	N/A
CSI reference signals 1		N/A	Antenna ports {15,16}
CSI-RS 1 periodicity and subframe offset $T_{\text{CSI-RS}} / \Delta_{\text{CSI-RS}}$	Subframes	N/A	5 / 2
CSI reference signal 1 configuration		N/A	8
Zero-power CSI-RS 0 configuration $l_{\text{CSI-RS}} /$ <i>ZeroPower CSI-RS</i> bitmap	Subframes /bitmap	2/ 0010000000000000	N/A
Zero-power CSI-RS1 configuration $l_{\text{CSI-RS}} /$ <i>ZeroPower CSI-RS</i> bitmaps	Subframes /bitmap	N/A	2/ 0000010000000000
\hat{E}_s / N_{oc}	dB	Reference Value in Table 8.3.1.3.2-3	Reference Value in Table 8.3.1.3.2-3
N_{oc} at antenna port	dBm/15kHz	-98	-98
BW_{Channel}	MHz	10	10
Cyclic Prefix		Normal	Normal
Cell Id		0	0
Number of control OFDM symbols		2	2
Timing offset between TPs		N/A	Reference Value in Table 8.3.1.3.2-3
Frequency offset between TPs	Hz	N/A	0
Number of allocated resource blocks	PRB	50	50
PDSCH transmission mode		10	10
Probability of occurrence of PDSCH transmission(Note 3)	%	30	70
Symbols for unused PRBs		OCNG (Note 4)	OCNG (Note 4)
<p>Note 1: $P_B = 1$</p> <p>Note 2: REs for antenna ports 0 and 1 have zero transmission power.</p> <p>Note 3: PDSCH transmission from TPs shall be randomly determined independently for each subframe. Probabilities of occurrence of PDSCH transmission from TPs are specified.</p> <p>Note 4: These physical resource blocks are assigned to an arbitrary number of virtual UEs with one PDSCH per virtual UE; the data transmitted over the OCNG PDSCHs shall be uncorrelated pseudo random data, which is QPSK modulated.</p>			

Table 8.3.1.3.2-2: Configurations of PQI and DL transmission hypothesis for each PQI set

PQI set index	Parameters in each PQI set		DL transmission hypothesis for each PQI Set	
	NZP CSI-RS Index (For quasi co-location)	ZP CSI-RS configuration	TP 1	TP 2
PQI set 0	CSI-RS 0	ZP CSI-RS 0	PDSCH	Blanked
PQI set 3	CSI-RS 1	ZP CSI-RS 1	Blanked	PDSCH

Table 8.3.1.3.2-3: Performance Requirements for timing offset compensation with DPS transmission

Test Number	Timing offset(us)	Reference Channel	OCNG Pattern		Propagation Conditions		Correlation Matrix and Antenna Configuration (Note 2)	Reference Value		UE Category
			TP 1	TP 2	TP 1	TP 2		Fraction of Maximum Throughput (%)	SNR (dB) (Note 3)	
1	2	R.53 FDD	OP.1 FDD	OP.1 FDD	EPA5	EPA5	2x2 Low	70	12.2	≥2
2	-0.5	R.53 FDD	OP.1 FDD	OP.1 FDD	EPA5	EPA5	2x2 Low	70	12.5	≥2

Note 1: The propagation conditions for TP 1 and TP 2 are statistically independent.
Note 2: Correlation matrix and antenna configuration parameters apply for each of TP 1 and TP 2.
Note 3: SNR corresponds to \hat{E}_s / N_{oc} of both TP 1 and TP 2 as defined in clause 8.1.1.

8.3.1.3.3 Minimum requirement with Different Cell ID and Colliding CRS (with single NZP CSI-RS resource)

The requirements are specified in Table 8.3.1.3.3-2, with the additional parameters in Table 8.3.1.3.3-1. The purpose of this test is to verify the UE capability of supporting non quasi-co-located antenna ports when the UE receives DCI format 2D in a scenario where the two transmission points have different Cell ID and colliding CRS. In particular the test verifies that the UE, configured with quasi co-location type B, performs correct tracking and compensation of the frequency difference between two transmission points, channel parameters estimation and rate matching behaviour according to the 'PDSCH RE Mapping and Quasi-Co-Location Indicator' signalling defined in [6]. In Table 8.3.1.3.3-1, transmission point 1 (TP 1) is serving cell transmitting PDCCH, synchronization signals and PBCH, and transmission point 2 (TP 2) transmits PDSCH with different Cell ID. The downlink physical channel setup for TP 1 is according to Table C.3.4-1 and for TP 2 according to Table C.3.4-2.

Table 8.3.1.3.3-1: Test Parameters for quasi co-location type B with different Cell ID and Colliding CRS

parameter	Unit	TP 1	TP 2
Downlink power allocation	ρ_A	dB	0
	ρ_B	dB	0 (Note 1)
	σ	dB	-3

Beamforming model		N/A	As specified in clause B.4.2
Cell-specific reference signals		Antenna ports 0,1	Antenna ports 0,1
CSI reference signals 0		N/A	Antenna ports {15,16}
CSI-RS 0 periodicity and subframe offset $T_{CSI-RS} / \Delta_{CSI-RS}$	Subframes	N/A	5 / 2
CSI reference signal 0 configuration		N/A	0
Zero-power CSI-RS 0 configuration $I_{CSI-RS} / ZeroPower\ CSI-RS\ bitmap$	Subframes /bitmap	N/A	2/ 0010000000000000
\hat{E}_s / N_{oc}	dB	Reference point in Table 8.3.1.3.3-2 + 4dB	Reference Value in Table 8.3.1.3.3-2
N_{oc} at antenna port	dBm/15kHz	-98	-98
$BW_{Channel}$	MHz	10	10
Cyclic Prefix		Normal	Normal
Cell Id		0	126
Number of control OFDM symbols		1	2
Timing offset between TPs	us	N/A	0
Frequency offset between TPs	Hz	N/A	200
<i>qcl-Operation, PDSCH RE Mapping and Quasi-Co-Location Indicator</i>		Type B, '00'	
PDSCH transmission mode		Blank	10
Number of allocated resource block		N/A	50
Symbols for unused PRBs		N/A	OCNG(Note2)
Note 1: $P_b = 1$ Note 2: These physical resource blocks are assigned to an arbitrary number of virtual UEs with one PDSCH per virtual UE; the data transmitted over the OCNG PDSCHs shall be uncorrelated pseudo random data, which is QPSK modulated.			

Table 8.3.1.3.3-2: Performance Requirements for quasi co-location type B with different Cell ID and Colliding CRS

Test Number	Reference Channel	OCNG Pattern		Propagation Conditions (Note1)		Correlation Matrix and Antenna Configuration (Note 2)	Reference Value		UE Category
		TP 1	TP 2	TP 1	TP 2		Fraction of Maximum Throughput (%)	SNR (dB) (Note 3)	
1	R.54 FDD	N/A	OP.1 FDD	EPA5	ETU5	2x2 Low	70	14.4	≥2
Note 1: The propagation conditions for TP.1 and TP.2 are statistically independent. Note 2: Correlation matrix and antenna configuration parameters apply for each of TP.1 and TP.2. Note 3: SNR corresponds to \hat{E}_s / N_{oc} of TP.2 as defined in clause 8.1.1.									

8.3.2 TDD

The parameters specified in Table 8.3.2-1 are valid for TDD unless otherwise stated.

Table 8.3.2-1: Common Test Parameters for User-specific Reference Symbols

Parameter	Unit	Value
Uplink downlink configuration (Note 1)		1
Special subframe configuration (Note 2)		4
Cyclic prefix		Normal
Cell ID		0
Inter-TTI Distance		1
Number of HARQ processes	Processes	7
Maximum number of HARQ transmission		4
Redundancy version coding sequence		{0,1,2,3} for QPSK and 16QAM {0,0,1,2} for 64QAM and 256QAM
Number of OFDM symbols for PDCCH	OFDM symbols	2
Precoder update granularity		Frequency domain: 1 PRB for Transmission mode 8, 1 PRG for Transmission modes 9 and 10 Time domain: 1 ms
ACK/NACK feedback mode		Multiplexing
Note 1: as specified in Table 4.2-2 in TS 36.211 [4]		
Note 2: as specified in Table 4.2-1 in TS 36.211 [4]		

8.3.2.1 Single-layer Spatial Multiplexing

For single-layer transmission on antenna port 5, the requirements are specified in Table 8.3.2.1-2, with the addition of the parameters in Table 8.3.2.1-1 and the downlink physical channel setup according to Annex C.3.2. The purpose is to verify the demodulation performance using user-specific reference signals with full RB or single RB allocation.

Table 8.3.2.1-1: Test Parameters for Testing DRS

Parameter	Unit	Test 1	Test 2	Test 3	Test 4	
Downlink power allocation	ρ_A	dB	0	0	0	0
	ρ_B	dB	0 (Note 1)	0 (Note 1)	0 (Note 1)	0 (Note 1)
	σ	dB	0	0	0	0
Cell-specific reference signals		Antenna port 0				
Beamforming model		Annex B.4.1				
N_{oc} at antenna port	dB/15kHz	-98	-98	-98	-98	
Symbols for unused PRBs		OCNG (Note 2)	OCNG (Note 2)	OCNG (Note 2)	OCNG (Note 2)	
PDSCH transmission mode		7	7	7	7	
Note 1: $P_B = 0$.						
Note 2: These physical resource blocks are assigned to an arbitrary number of virtual UEs with one PDSCH per virtual UE; the data transmitted over the OCNG PDSCHs shall be uncorrelated pseudo random data, which is QPSK modulated.						

Table 8.3.2.1-2: Minimum performance DRS (FRC)

Test number	Bandwidth and MCS	Reference Channel	OCNG Pattern	Propagation Condition	Correlation Matrix and Antenna Configuration	Reference value		UE Category
						Fraction of Maximum Throughput (%)	SNR (dB)	
1	10 MHz QPSK 1/3	R.25 TDD	OP.1 TDD	EPA5	2x2 Low	70	-0.8	≥1
2	10 MHz 16QAM 1/2	R.26 TDD	OP.1 TDD	EPA5	2x2 Low	70	7.0	≥2
	5MHz 16QAM 1/2	R.26-1 TDD	OP.1 TDD	EPA5	2x2 Low	70	7.0	1
3	10 MHz 64QAM 3/4	R.27 TDD	OP.1 TDD	EPA5	2x2 Low	70	17.0	≥2
	10 MHz 64QAM 3/4	R.27-1 TDD	OP.1 TDD	EPA5	2x2 Low	70	17.0	1
4	10 MHz 16QAM 1/2	R.28 TDD	OP.1 TDD	EPA5	2x2 Low	30	1.7	≥1

For single-layer transmission on antenna ports 7 or 8 upon detection of a PDCCH with DCI format 2B, the requirements are specified in Table 8.3.2.1-4 and 8.3.2.1-5, with the addition of the parameters in Table 8.3.2.1-3 and the downlink physical channel setup according to Annex C.3.2. The purpose of these tests is to verify rank-1 performance on one of the antenna ports 7 or 8 with and without a simultaneous transmission on the other antenna port.

Table 8.3.2.1-3: Test Parameters for Testing CDM-multiplexed DM RS (single layer)

Parameter	Unit	Test 1	Test 2	Test 3	Test 4	Test 5
Downlink power allocation	ρ_A	dB	0	0	0	0
	ρ_B	dB	0 (Note 1)	0 (Note 1)	0 (Note 1)	0 (Note 1)
	σ	dB	-3	-3	-3	-3
Cell-specific reference signals		Antenna port 0 and antenna port 1				
Beamforming model		Annex B.4.1				
N_{oc} at antenna port	dBm/15kHz	-98	-98	-98	-98	-98
Symbols for unused PRBs		OCNG (Note 4)	OCNG (Note 4)	OCNG (Note 4)	OCNG (Note 4)	OCNG (Note 4)
Simultaneous transmission		No	No	No	Yes (Note 3, 5)	Yes (Note 3, 5)
PDSCH transmission mode		8	8	8	8	8
Note 1: $P_B = 1$. Note 2: The modulation symbols of the signal under test is mapped onto antenna port 7 or 8. Note 3: Modulation symbols of an interference signal is mapped onto the antenna port (7 or 8) not used for the input signal under test. Note 4: These physical resource blocks are assigned to an arbitrary number of virtual UEs with one PDSCH per virtual UE; the data transmitted over the OCNG PDSCHs shall be uncorrelated pseudo random data, which is QPSK modulated. Note 5: The two UEs' scrambling identities n_{SCID} are set to 0 for CDM-multiplexed DM RS with interfering simultaneous transmission test cases.						

Table 8.3.2.1-4: Minimum performance for CDM-multiplexed DM RS without simultaneous transmission (FRC)

Test number	Bandwidth and MCS	Reference Channel	OCNG Pattern	Propagation Condition	Correlation Matrix and Antenna Configuration	Reference value		UE Category
						Fraction of Maximum Throughput (%)	SNR (dB)	
1	10 MHz QPSK 1/3	R.31 TDD	OP.1 TDD	EVA5	2x2 Low	70	-1.0	≥1
2	10 MHz 16QAM 1/2	R.32 TDD	OP.1 TDD	EPA5	2x2 Medium	70	7.7	≥2
	5MHz 16QAM 1/2	R.32-1 TDD	OP.1 TDD	EPA5	2x2 Medium	70	7.7	1
3	10 MHz 64QAM 3/4	R.33 TDD	OP.1 TDD	EPA5	2x2 Low	70	17.7	≥2
	10 MHz 64QAM 3/4	R.33-1 TDD	OP.1 TDD	EPA5	2x2 Low	70	17.7	1

Table 8.3.2.1-5: Minimum performance for CDM-multiplexed DM RS with interfering simultaneous transmission (FRC)

Test number	Bandwidth and MCS	Reference Channel	OCNG Pattern	Propagation Condition	Correlation Matrix and Antenna Configuration	Reference value		UE Category
						Fraction of Maximum Throughput (%)	SNR (dB)	
4	10 MHz 16QAM 1/2	R.32 TDD (Note 1)	OP.1 TDD	EPA5	2x2 Medium	70	21.9	≥2
5	10 MHz 64QAM 1/2	R.34 TDD (Note 1)	OP.1 TDD	EPA5	2x2 Low	70	22.0	≥2

Note 1: The reference channel applies to both the input signal under test and the interfering signal.

8.3.2.1A Single-layer Spatial Multiplexing (with multiple CSI-RS configurations)

For single-layer transmission on antenna ports 7 or 8 upon detection of a PDCCH with DCI format 2C, the requirements are specified in Table 8.3.2.1A-2 and 8.3.2.1A-3, with the addition of the parameters in Table 8.3.2.1A-1 and the downlink physical channel setup according to Annex C.3.2. The purpose of these tests is to verify rank-1 performance on one of the antenna ports 7 or 8 with and without a simultaneous transmission on the other antenna port, and to verify rate matching with multiple CSI reference symbol configurations with non-zero and zero transmission power.

Table 8.3.2.1A-1: Test Parameters for Testing CDM-multiplexed DM RS (single layer) with multiple CSI-RS configurations

Parameter		Unit	Test 1	Test 2	Test 3
Downlink power allocation	ρ_A	dB	0	0	0
	ρ_B	dB	0 (Note 1)	0 (Note 1)	0 (Note 1)
	σ	dB	-3	-3	-3
Cell-specific reference signals			Antenna ports 0,1		
CSI reference signals			Antenna ports 15,...,22	Antenna ports 15,...,18	Antenna ports 15,...,18
Beamforming model			Annex B.4.1	Annex B.4.1	Annex B.4.1
CSI-RS periodicity and subframe offset $T_{CSI-RS} / \Delta_{CSI-RS}$		Subframes	5 / 4	5 / 4	5 / 4
CSI reference signal configuration			1	3	3
Zero-power CSI-RS configuration $I_{CSI-RS} / ZeroPowerCSI-RS$ bitmap		Subframes / bitmap	4 / 0010000100000000	4 / 0010000000000000	4 / 0010000000000000
N_{oc} at antenna port		dBm/15kHz	-98	-98	-98
Symbols for unused PRBs			OCNG (Note 4)	OCNG (Note 4)	OCNG (Note 4)
Number of allocated resource blocks (Note 2)		PRB	50	50	100
Simultaneous transmission			No	Yes (Note 3, 5)	No
PDSCH transmission mode			9	9	9
<p>Note 1: $P_B = 1$.</p> <p>Note 2: The modulation symbols of the signal under test are mapped onto antenna port 7 or 8.</p> <p>Note 3: Modulation symbols of an interference signal is mapped onto the antenna port (7 or 8) not used for the input signal under test.</p> <p>Note 4: These physical resource blocks are assigned to an arbitrary number of virtual UEs with one PDSCH per virtual UE; the data transmitted over the OCNG PDSCHs shall be uncorrelated pseudo random data, which is QPSK modulated.</p> <p>Note 5: The two UEs' scrambling identities n_{SCID} are set to 0 for CDM-multiplexed DM RS with interfering simultaneous transmission test cases.</p>					

Table 8.3.2.1A-2: Minimum performance for CDM-multiplexed DM RS without simultaneous transmission (FRC) with multiple CSI-RS configurations

Test number	Bandwidth and MCS	Reference Channel	OCNG Pattern	Propagation Condition	Correlation Matrix and Antenna Configuration	Reference value		UE Category	UE DL Category
						Fraction of Maximum Throughput (%)	SNR (dB)		
1	10 MHz QPSK 1/3	R.50 TDD	OP.1 TDD	EVA5	2x2 Low	70	-0.6	≥1	≥6
3	20MHz 256QAM	R. 66 TDD	OP.1 TDD	EPA5	2x2 Low	70	24.3	11-12	≥11

Table 8.3.2.1A-3: Minimum performance for CDM-multiplexed DM RS with interfering simultaneous transmission (FRC) with multiple CSI-RS configurations

Test number	Bandwidth and MCS	Reference Channel	OCNG Pattern	Propagation Condition	Correlation Matrix and Antenna Configuration	Reference value		UE Category
						Fraction of Maximum Throughput (%)	SNR (dB)	
2	10 MHz 64QAM 1/2	R.44 TDD	OP.1 TDD	EPA5	2x2 Low	70	22.1	≥2

Note 1: The reference channel applies to both the input signal under test and the interfering signal.

8.3.2.1B Enhanced Performance Requirement Type A – Single-layer Spatial Multiplexing with TM9 interference model

The requirements are specified in Table 8.3.2.1B-2, with the addition of the parameters in Table 8.3.2.1B-1 and the downlink physical channel setup according to Annex C.3.2. The purpose of these tests is to verify closed-loop rank one performance on one of the antenna ports 7 or 8 without a simultaneous transmission on the other antenna port in the serving cell when the PDSCH transmission in the serving cell is interfered by PDSCH of one dominant interfering cell applying transmission mode 9 interference model defined in clause B.5.4. In 8.3.2.1B-1, Cell 1 is the serving cell, and Cell 2 is the interfering cell. The downlink physical channel setup is according to Annex C.3.2 for each of Cell 1 and Cell 2, respectively.

Table 8.3.2.1B-1: Test Parameters for Testing CDM-multiplexed DM RS (single layer) with TM9 interference model

parameter		Unit	Cell 1	Cell 2
Downlink power allocation	ρ_A	dB	0	0
	ρ_B	dB	0 (Note 1)	0
	σ	dB	-3	-3
Cell-specific reference signals			Antenna ports 0,1	Antenna ports 0,1
CSI reference signals			Antenna ports 15,...,18	N/A
CSI-RS periodicity and subframe offset $T_{\text{CSI-RS}} / \Delta_{\text{CSI-RS}}$		Subframes	5 / 4	N/A
CSI reference signal configuration			0	N/A
N_{oc} at antenna port		dBm/15kHz	-98	N/A
DIP (Note 2)		dB	N/A	-1.73
BW_{Channel}		MHz	10	10
Cyclic Prefix			Normal	Normal
Cell Id			0	126
Number of control OFDM symbols			2	2
PDSCH transmission mode			9	N/A
Beamforming model			As specified in clause B.4.3 (Note 4, 5)	N/A
Interference model			N/A	As specified in clause B.5.4
Probability of occurrence of transmission rank in interfering cells	Rank 1		N/A	70
	Rank 2		N/A	30
Precoder update granularity		PRB	50	6
PMI delay (Note 5)		ms	10 or 11	N/A
Reporting interval		ms	5	N/A
Reporting mode			PUCCH 1-1	N/A
CodeBookSubsetRestriction bitmap			0000000000000000 0000000000000000 0000000000000000 1111111111111111	N/A
Symbols for unused PRBs			OCNG (Note 6)	N/A
Simultaneous transmission			No simultaneous transmission on the other antenna port in (7 or 8) not used for the input signal under test	N/A
Physical channel for CQI reporting			PUSCH(Note 8)	N/A
cqi-pmi-ConfigurationIndex			4	N/A
<p>Note 1: $P_B = 1$</p> <p>Note 2: The respective received power spectral density of each interfering cell relative to N_{oc} is defined by its associated DIP value as specified in clause B.5.1.</p> <p>Note 3: The modulation symbols of the signal under test in Cell 1 are mapped onto antenna port 7 or 8.</p>				

Note 4:	The precoder in clause B.4.3 follows UE recommended PMI.
Note 5:	If the UE reports in an available uplink reporting instance at subframe SF#n based on PMI estimation at a downlink SF not later than SF#(n-4), this reported PMI cannot be applied at the eNB downlink before SF#(n+4).
Note 6:	These physical resource blocks are assigned to an arbitrary number of virtual UEs with one PDSCH per virtual UE; the data transmitted over the OCNG PDSCHs shall be uncorrelated pseudo random data, which is QPSK modulated.
Note 7:	All cells are time-synchronous.
Note 8:	To avoid collisions between CQI reports and HARQ-ACK it is necessary to report both on PUSCH instead of PUCCH. PDCCH DCI format 0 shall be transmitted in downlink SF#4 and #9 to allow periodic CQI to multiplex with the HARQ-ACK on PUSCH in uplink subframe SF#8 and #3.

Table 8.3.2.1B-2: Enhanced Performance Requirement Type A, CDM-multiplexed DM RS with TM9 interference model

Test Number	Reference Channel	OCNG Pattern		Propagation Conditions		Correlation Matrix and Antenna Configuration (Note 3)	Reference Value		UE Category
		Cell 1	Cell 2	Cell 1	Cell 2		Fraction of Maximum Throughput (%)	SINR (dB) (Note 2)	
1	R.48 TDD	OP.1 TDD	N/A	EVA5	EVA5	4x2 Low	70	-1.0	≥1
Note 1: The propagation conditions for Cell 1 and Cell 2 are statistically independent. Note 2: SINR corresponds to \hat{E}_s / N_{oc} of Cell 1 as defined in clause 8.1.1. Note 3: Correlation matrix and antenna configuration parameters apply for each of Cell 1 and Cell 2.									

8.3.2.1C Single-layer Spatial Multiplexing (demodulation subframe overlaps with aggressor cell ABS and CRS assistance information are configured)

The requirements are specified in Table 8.3.2.1C-2, with the addition of parameters in Table 8.3.2.1C-1. The purpose is to verify the performance of the antenna ports 7 or 8 without a simultaneous transmission on the other antenna port in the serving cell if the PDSCH transmission in the serving cell takes place in subframes that overlap with ABS [9] of the aggressor cell with CRS assistance information. In Table 8.3.2.1C-1, Cell 1 is the serving cell, and Cell 2 and Cell 3 are the aggressor cells. The downlink physical channel setup for Cell 1 is according to Annex C.3.2 and for Cell 2 and Cell 3 is according to Annex C.3.3, respectively. The CRS assistance information [7] includes Cell 2 and Cell 3.

Table 8.3.2.1C-1: Test parameters of TM9-Single-Layer (2 CSI-RS ports) – Non-MBSFN ABS

Parameter		Unit	Cell 1	Cell 2	Cell 3
Uplink downlink Configuration			1	1	1
Special subframe configuration			4	4	4
Downlink power allocation	ρ_A	dB	0	-3	-3
	ρ_B	dB	0 (Note 1)	-3 (Note 1)	-3 (Note 1)
	σ	dB	-3	N/A	N/A
N_{oc} at antenna port	N_{oc1}	dBm/15kHz	-98 (Note 2)	N/A	N/A
	N_{oc2}	dBm/15kHz	-98 (Note 3)	N/A	N/A
	N_{oc3}	dBm/15kHz	-93 (Note 4)	N/A	N/A
\hat{E}_s / N_{oc2}		dB	Reference Value in Table 8.3.2.1C-2	12	10
BW _{Channel}		MHz	10	10	10
Subframe Configuration			Non-MBSFN	Non-MBSFN	Non-MBSFN
Time Offset between Cells		μs	N/A	3	-1
Frequency shift between Cells		Hz	N/A	300	-100
Cell Id			0	1	126
Cell-specific reference signals			Antenna ports 0,1		
CSI reference signals			Antenna ports 15,16	N/A	N/A
CSI-RS periodicity and subframe offset $T_{CSI-RS} / \Delta_{CSI-RS}$		Subframes	5 / 4	N/A	N/A
CSI reference signal configuration			8	N/A	N/A
Zero-power CSI-RS configuration $I_{CSI-RS} / \text{ZeroPowerCSI-RS bitmap}$		Subframes / bitmap	4 / 00100000000000 00	N/A	N/A
ABS pattern (Note 5)			N/A	000000001 000000001	000000001 000000001
RLM/RRM Measurement Subframe Pattern (Note 6)			000000001 000000001	N/A	N/A
CSI Subframe Sets (Note7)	$C_{CSI,0}$		000000001 000000001	N/A	N/A
	$C_{CSI,1}$		1100111000 1100111000	N/A	N/A
Number of control OFDM symbols			2	Note 8	Note 8
PDSCH transmission mode			TM9-1layer	Note 9	Note 9
Precoding granularity			Frequency domain: 1 PRG Time domain: 1 ms	N/A	N/A
Beamforming model			Annex B.4.1	N/A	N/A
Cyclic prefix			Normal	Normal	Normal

- Note 1: $P_B = 1$.
- Note 2: This noise is applied in OFDM symbols #1, #2, #3, #5, #6, #8, #9, #10, #12, #13 of a subframe overlapping with the aggressor ABS.
- Note 3: This noise is applied in OFDM symbols #0, #4, #7, #11 of a subframe overlapping with the aggressor ABS.
- Note 4: This noise is applied in all OFDM symbols of a subframe overlapping with aggressor non-ABS
- Note 5: ABS pattern as defined in [9]. PDSCH other than SIB1/paging and its associated PDCCH/PCFICH are transmitted in the serving cell subframe when the subframe is overlapped with the ABS subframe of aggressor cell and the subframe is available in the definition of the reference channel.
- Note 6: Time-domain measurement resource restriction pattern for PCell measurements as defined in [7]
- Note 7: As configured according to the time-domain measurement resource restriction pattern for CSI measurements defined in [7].
- Note 8: The number of control OFDM symbols is not available for ABS and is 2 for the subframe indicated by "0" of ABS pattern.
- Note 9: Downlink physical channel setup in Cell 2 and Cell 3 in accordance with Annex C.3.3 applying OCNG pattern as defined in Annex A.5.
- Note 10: If the UE reports in an available uplink reporting instance at subframe SF#n based on PMI estimation at a downlink SF not later than SF#(n-4), this reported PMI cannot be applied at the eNB downlink before SF#(n+4).
- Note 11: For Uplink - downlink configuration 1 the reporting interval will alternate between 1ms and 4ms.
- Note 12: The number of the CRS ports in Cell 1, Cell 2 and Cell 3 is the same.
- Note 13: SIB-1 will not be transmitted in Cell 2 and Cell 3 in this test.
- Note 14: The modulation symbols of the signal under test are mapped onto antenna port 7 or 8.

Table 8.3.2.1C-2: Minimum Performance of TM9-Single-Layer (2 CSI-RS ports) – Non-MBSFN ABS

Test Number	Reference Channel	OCNG Pattern			Propagation Conditions (Note1)			Correlation Matrix and Antenna Configuration (Note 2)	Reference Value		UE Category
		Cell 1	Cell 2	Cell 3	Cell 1	Cell 2	Cell 3		Fraction of Maximum Throughput (%)	SNR (dB) (Note 3)	
1	R.51 TDD	OP.1 TDD	OP.1 TDD	OP.1 TDD	EVA5			2x2 Low	70	8.5	≥2
Note 1: The propagation conditions for Cell 1, Cell 2 and Cell 3 are statistically independent. Note 2: The correlation matrix and antenna configuration apply for Cell 1, Cell 2 and Cell 3. Note 3: SNR corresponds to \hat{E}_s / N_{oc2} of cell 1.											

8.3.2.1D Enhanced Performance Requirement Type B – Single-layer Spatial Multiplexing with TM9 interference

The requirements are specified in Table 8.3.2.1D-2, with the addition of the parameters in Table 8.3.2.1D-1 and the downlink physical channel setup according to Annex C.3.2. The purpose of these tests is to verify closed loop rank one performance on one of the antenna ports 7 or 8 without a simultaneous transmission on the other antenna port in the serving cell when the PDSCH transmission in the serving cell is interfered by PDSCH of two interfering cells applying transmission mode 9 interference model defined in clause B.6.4. In 8.3.2.1D-1, Cell 1 is the serving cell, and Cell 2, 3 are interfering cells. The downlink physical channel setup is according to Annex C.3.2 for each of Cell 1, Cell 2 and Cell 3, respectively.

Table 8.3.2.1D-1: Test Parameters for Testing CDM-multiplexed DM RS (Single-layer) with TM9 interference model

Parameter		Unit	Cell 1	Cell 2	Cell 3
Uplink downlink Configuration			1	1	1
Special subframe configuration			4	4	4
Downlink power allocation	ρ_A	dB	0	0	0
	ρ_B	dB	0 (NOTE 1)	0	0
	σ	dB	-3	-3	-3
Cell-specific reference signals			Antenna ports 0,1	Antenna ports 0,1	Antenna ports 0,1
N_{oc} at antenna port		dBm/15kHz	-98		
\hat{E}_s/N_{oc}		dB	N/A	13.91	3.34
$BW_{Channel}$		MHz	10	10	10
Cyclic Prefix			Normal	Normal	Normal
Cell Id			0	1	6
Number of control OFDM symbols in normal subframes			3	3	3
CFI indicated in PCFICH in normal subframes			3	3	3
Number of control OFDM symbols in special subframes			2	2	2
CFI indicated in PCFICH in special subframes			2	2	2
PDSCH transmission mode			9	9	9
Interference model			N/A	As specified in clause B.6.4	As specified in clause B.6.4
Precoding			Random wideband precoding per TTI	As specified in clause B.6.4	As specified in clause B.6.4
CSI reference signals			Antenna ports 15, 16, 17, 18	Antenna ports 15, 16	Antenna ports 15, 16
CSI-RS periodicity and subframe offset $T_{CSI-RS} / \Delta_{CSI-RS}$		Subframes	10 / 4	10 / 4	10 / 4
CSI reference signal configuration			5	6	7
Zero-power CSI-RS configuration $I_{CSI-RS} / ZeroPowerCSI-RS$ bitmap		Subframes / bitmap	9/ 1000000000 00000	9/ 01000000000 0000	9/ 00100000000 00000
Time offset to cell 1		us	N/A	2	3
Frequency offset to cell 1		Hz	N/A	200	300
MBSFN			Not configured	Not configured	Not configured
NeighCellsInfo-r12 (NOTE 4)	p-aList-r12		N/A	{dB-6, dB-3, dB0}	{dB-6, dB-3, dB0}
	transmissionModeList-r12		N/A	{2,3,4,8,9}	{2,3,4,8,9}
NOTE 1: $P_B = 1$					
NOTE 2: Cell 1 is the serving cell. Cell 2, 3 are the interfering cells.					
NOTE 3: CSI-RS configurations are according to [4] subclause 6.10.5.2.					
NOTE 4: NeighCellsInfo-r12 is described in subclause 6.3.2 of [7].					

Table 8.3.2.1D-2: Minimum Performance for Enhanced Performance Requirement Type B, CDM-multiplexed DM RS with TM9 interference model

Test Number	Reference Channel	OCNG Pattern			Propagation Conditions			Correlation Matrix and Antenna Configuration			Reference Value		UE Category
		Cell 1	Cell 2	Cell 3	Cell 1	Cell 2	Cell 3	Cell 1	Cell 2	Cell 3	Fraction of Maximum Throughput (%)	SNR (dB) (NOTE 2)	
1	R.69 TDD	OP. 1 TDD	N/A	N/A	EP A5	EP A5	EP A5	4x2 Low	2x2 Low	2x2 Low	85	18.0	≥1

NOTE 1: The propagation conditions for Cell 1, Cell 2 and Cell 3 are statistically independent.

NOTE 2: SNR corresponds to \hat{E}_s/N_{oc} of Cell 1 as defined in clause 8.1.1.

8.3.2.1E Enhanced Performance Requirement Type B – Single-layer Spatial Multiplexing with CRS interference model

The requirements are specified in Table 8.3.2.1E-2, with the addition of the parameters in Table 8.3.2.1E-1 and the downlink physical channel setup according to Annex C.3.2. The purpose of these tests is to verify closed loop rank one performance on one of the antenna ports 7 or 8 without a simultaneous transmission on the other antenna port in the serving cell when the PDSCH transmission in the serving cell is interfered by the CRS of the interfering cell, applying the CRS interference model defined in clause B.6.5. In 8.3.2.1E-1, Cell 1 is the serving cell, and Cell 2, 3 are interfering cells. The downlink physical channel setup is according to Annex C.3.2 for each of Cell 1, Cell 2 and Cell 3, respectively.

Table 8.3.2.1E-1: Test Parameters for Testing CDM-multiplexed DM RS (Single-layer) with CRS interference model

Parameter		Unit	Cell 1	Cell 2	Cell 3
Uplink downlink Configuration			1	1	1
Special subframe configuration			4	4	4
Downlink power allocation	ρ_A	dB	0	0	0
	ρ_B	dB	0 (NOTE 1)	0	0
	σ	dB	-3	-3	-3
Cell-specific reference signals			Antenna ports 0,1	Antenna ports 0,1	Antenna ports 0,1
N_{oc} at antenna port		dBm/15kHz	-98		
\hat{E}_s/N_{oc}		dB	N/A	13.91	3.34
BW _{Channel}		MHz	10	10	10
Cyclic Prefix			Normal	Normal	Normal
Cell Id			0	1	6
Number of control OFDM symbols in normal subframes			3	3	3
CFI indicated in PCFICH in normal subframes			3	3	3
Number of control OFDM symbols in special subframes			2	2	2
CFI indicated in PCFICH in special subframes			2	2	2
PDSCH transmission mode			8	N/A	N/A
Interference model			N/A	As specified in clause B.6.5	As specified in clause B.6.5
Precoding			Random wideband precoding per TTI	N/A	N/A
Time offset to cell 1		us	N/A	2	3
Frequency offset to cell 1		Hz	N/A	200	300
MBSFN			Not configured	Not configured	Not configured
NeighCellsInfo-r12 (NOTE 3)	p-aList-r12		N/A	{dB-6, dB-3, dB0}	{dB-6, dB-3, dB0}
	transmissionModeList-r12		N/A	{2,3,4,8,9}	{2,3,4,8,9}
NOTE 1: $P_B = 1$					
NOTE 2: Cell 1 is the serving cell. Cell 2, 3 are the interfering cells.					
NOTE 3: NeighCellsInfo-r12 is described in subclause 6.3.2 of [7].					

Table 8.3.2.1E-2: Minimum Performance for Enhanced Performance Requirement Type B, CDM-multiplexed DM RS with CRS interference model

Test Number	Reference Channel	OCNG Pattern			Propagation Conditions			Correlation Matrix and Antenna Configuration (NOTE 3)	Reference Value		UE Category
		Cell 1	Cell 2	Cell 3	Cell 1	Cell 2	Cell 3		Fraction of Maximum Throughput (%)	SNR (dB) (NOTE 2)	
1	R.71 TDD	OP. 1 TD D	N/A	N/A	EP A5	EP A5	EP A5	2x2 Low	85	14.0	≥2
NOTE 1: The propagation conditions for Cell 1, Cell 2 and Cell 3 are statistically independent.											
NOTE 2: SNR corresponds to \hat{E}_s/N_{oc} of Cell 1 as defined in clause 8.1.1.											
NOTE 3: Correlation matrix and antenna configuration parameters apply for each of Cell 1, Cell 2 and Cell 3.											

8.3.2.1F Enhanced Performance Requirement Type B – Single-layer Spatial Multiplexing with TM3 interference

The requirements are specified in Table 8.3.2.1F-2, with the addition of the parameters in Table 8.3.2.1F-1 and the downlink physical channel setup according to Annex C.3.2. The purpose of these tests is to verify closed loop rank one performance on one of the antenna ports 7 or 8 without a simultaneous transmission on the other antenna port in the serving cell when the PDSCH transmission in the serving cell is interfered by PDSCH of two interfering cells applying transmission mode 3 interference model defined in clause B.6.2. In 8.3.2.1F-1, Cell 1 is the serving cell, and Cell 2, 3 are interfering cells. The downlink physical channel setup is according to Annex C.3.2 for each of Cell 1, Cell 2 and Cell 3, respectively.

Table 8.3.2.1F-1: Test Parameters for Testing CDM-multiplexed DM RS (Single-layer) with TM3 interference model

Parameter		Unit	Cell 1	Cell 2	Cell 3
Uplink downlink Configuration			1	1	1
Special subframe configuration			4	4	4
Downlink power allocation	ρ_A	dB	0	-3	-3
	ρ_B	dB	0 (NOTE 1)	-3	-3
	σ	dB	-3	0	0
Cell-specific reference signals			Antenna ports 0,1	Antenna ports 0,1	Antenna ports 0,1
N_{oc} at antenna port		dBm/15kHz	-98		
\hat{E}_s/N_{oc}		dB	N/A	3.28	0.74
BW _{Channel}		MHz	10	10	10
Cyclic Prefix			Normal	Normal	Normal
Cell Id			0	1	6
Number of control OFDM symbols in normal subframes			3	3	3
CFI indicated in PCFICH in normal subframes			3	Random from set {1,2,3}	Random from set {1,2,3}
Number of control OFDM symbols in special subframes			2	2	2
CFI indicated in PCFICH in special subframes			2	Random from set {1,2}	Random from set {1,2}
PDSCH transmission mode			8	3	3
Interference model			N/A	As specified in clause B.6.2	As specified in clause B.6.2
Precoding			Random wideband precoding per TTI	As specified in clause B.6.2	As specified in clause B.6.2
Time offset to cell 1		us	N/A	2	3
Frequency offset to cell 1		Hz	N/A	200	300
MBSFN			Not configured	Not configured	Not configured
NeighCellsInfo-r12 (NOTE 4)	p-aList-r12		N/A	{dB-6, dB-3, dB0}	{dB-6, dB-3, dB0}
	transmissionModelList-r12		N/A	{2,3,4,8,9}	{2,3,4,8,9}
NOTE 1: $P_B = 1$					
NOTE 2: Cell 1 is the serving cell. Cell 2, 3 are the interfering cells.					
NOTE 3: CSI-RS configurations are according to [4] subclause 6.10.5.2.					
NOTE 4: NeighCellsInfo-r12 is described in subclause 6.3.2 of [7].					

Table 8.3.2.1F-2: Minimum Performance for Enhanced Performance Requirement Type B, CDM-multiplexed DM RS with TM3 interference model

Test Number	Reference Channel	OCNG Pattern			Propagation Conditions			Correlation Matrix and Antenna Configuration (NOTE 3)	Reference Value		UE Category
		Cell 1	Cell 2	Cell 3	Cell 1	Cell 2	Cell 3		Fraction of Maximum Throughput (%)	SNR (dB) (NOTE 2)	
1	R.70 TDD	OP. 1 TD D	N/A	N/A	EP A5	EP A5	EP A5	2x2 Low	85	11.3	≥1

NOTE 1: The propagation conditions for Cell 1, Cell 2 and Cell 3 are statistically independent.

NOTE 2: SNR corresponds to \hat{E}_s/N_{oc} of Cell 1 as defined in clause 8.1.1.

NOTE 3: Correlation matrix and antenna configuration parameters apply for each of Cell 1, Cell 2 and Cell 3.

8.3.2.1G Enhanced Performance Requirement Type B – Single-layer Spatial Multiplexing with TM10 serving cell configuration and TM9 interference model

The requirements are specified in Table 8.3.2.1G-2, with the addition of the parameters in Table 8.3.2.1G-1 and the downlink physical channel setup according to Annex C.3.2. The purpose of these tests is to verify closed loop rank one performance on one of the antenna ports 7 or 8 without a simultaneous transmission on the other antenna port in the serving cell when the PDSCH transmission configured with TM10 in the serving cell is interfered by PDSCH of one dominant interfering cell applying transmission mode 9 interference model defined in clause B.6.3. The NAICS network assistance is provided when the serving cell TM10 is configured with QCL-type A and PCID based DM-RS scrambling. The neighbouring cell has transmission mode TM9 and NeighCellsInfo-r12 for interfering cell indicates presence of TM9. In 8.3.2.1G-1, Cell 1 is the serving cell, and Cell 2, 3 are interfering cells. The downlink physical channel setup is according to Annex C.3.2 for each of Cell 1, Cell 2 and Cell 3, respectively.

Table 8.3.2.1G-1: Test Parameters for Testing CDM-multiplexed DM RS (single layer) Multiplexing with TM10 serving cell configuration and TM9 interference model

Parameter		Unit	Cell 1	Cell 2	Cell 3
Uplink downlink Configuration			1	1	1
Special subframe configuration			4	4	4
Downlink power allocation	ρ_A	dB	0	0	0
	ρ_B	dB	0 (Note 1)	0	0
	σ	dB	-3	-3	-3
Cell-specific reference signals			Antenna ports 0,1	Antenna ports 0,1	Antenna ports 0,1
N_{oc} at antenna port		dBm/15kHz	-98		
\hat{E}_s / N_{oc}		dB	N/A	13.91	3.34
BW _{Channel}		MHz	10	10	10
Cyclic Prefix			Normal	Normal	Normal
Cell Id			0	1	6
Number of control OFDM symbols in normal subframes			3	3	3
CFI indicated in PCFICH in normal subframes			3	3	3
Number of control OFDM symbols in special subframes			2	2	2
CFI indicated in PCFICH in special subframes			2	2	2
PDSCH transmission mode			10	9	9
Interference model			N/A	As specified in clause B.6.4	As specified in clause B.6.4
Precoding			Random wideband precoding per TTI	As specified in clause B.6.4	As specified in clause B.6.4
CSI reference signals			Antenna ports 15, 16, 17, 18	Antenna ports 15, 16	Antenna ports 15, 16
CSI-RS periodicity and subframe offset $T_{CSI-RS} / \Delta_{CSI-RS}$		Subframes	10 / 4	10 / 4	10 / 4
CSI reference signal configuration			5	6	7
Zero-power CSI-RS configuration $l_{CSI-RS} / \text{ZeroPowerCSI-RS}$ bitmap		Subframes / bitmap	9 / 1000000000 00000	9 / 01000000000 0000	9 / 00100000000 00000
Time offset to cell 1		us	N/A	2	3
Frequency offset to cell 1		Hz	N/A	200	300
MBSFN			Not configured	Not configured	Not configured
NeighCellsInfo-r12 (Note 4)	p-aList-r12		N/A	{dB-6, dB-3, dB0}	{dB-6, dB-3, dB0}
	transmissionModelList-r12		N/A	{2,3,4,8,9}	{2,3,4,8,9}
Note 1: $P_B = 1$					
Note 2: Cell 1 is the serving cell. Cell 2, 3 are the interfering cells.					
Note 3: CSI-RS configurations are according to [4] subclause 6.10.5.2.					
Note 4: NeighCellsInfo-r12 is described in subclause 6.3.2 of [7].					

Table 8.3.2.1G-2: Minimum Performance for Enhanced Performance Requirement Type B, CDM-multiplexed DM RS Multiplexing with TM10 serving cell configuration and TM9 interference model

Test Number	Reference Channel	OCNG Pattern			Propagation Conditions			Correlation Matrix and Antenna Configuration			Reference Value		UE Category
		Cell 1	Cell 2	Cell 3	Cell 1	Cell 2	Cell 3	Cell 1	Cell 2	Cell 3	Fraction of Maximum Throughput (%)	SNR (dB) (Note 2)	
1	R.69 TDD	OP. 1 TDD	N/A	N/A	EP A5	EP A5	EP A5	4x Low	2x Low	2x Low	85	18.0	≥1

Note 1: The propagation conditions for Cell 1, Cell 2 and Cell 3 are statistically independent.

Note 2: SINR corresponds to \hat{E}_s/N_{oc} of Cell 1 as defined in clause 8.1.1.

8.3.2.2 Dual-Layer Spatial Multiplexing

For dual-layer transmission on antenna ports 7 and 8 upon detection of a PDCCH with DCI format 2B, the requirements are specified in Table 8.3.2.2-2, with the addition of the parameters in Table 8.3.2.2-1 and the downlink physical channel setup according to Annex C.3.2. The purpose of these tests is to verify the rank-2 performance for full RB allocation.

Table 8.3.2.2-1: Test Parameters for Testing CDM-multiplexed DM RS (dual layer)

Parameter		Unit	Test 1	Test 2
Downlink power allocation	ρ_A	dB	0	0
	ρ_B	dB	0 (Note 1)	0 (Note 1)
	σ	dB	-3	-3
Cell-specific reference symbols			Antenna port 0 and antenna port 1	
Beamforming model			Annex B.4.2	
N_{oc} at antenna port		dBm/15kHz	-98	-98
Symbols for unused PRBs			OCNG (Note 2)	OCNG (Note 2)
Number of allocated resource blocks		PRB	50	50
PDSCH transmission mode			8	8
Note 1: $P_B = 1$. Note 2: These physical resource blocks are assigned to an arbitrary number of virtual UEs with one PDSCH per virtual UE; the data transmitted over the OCNG PDSCHs shall be uncorrelated pseudo random data, which is QPSK modulated.				

Table 8.3.2.2-2: Minimum performance for CDM-multiplexed DM RS (FRC)

Test number	Bandwidth and MCS	Reference Channel	OCNG Pattern	Propagation Condition	Correlation Matrix and Antenna Configuration	Reference value		UE Category
						Fraction of Maximum Throughput (%)	SNR (dB)	
1	10 MHz QPSK 1/3	R.31 TDD	OP.1 TDD	EVA5	2x2 Low	70	4.5	≥2
2	10 MHz 16QAM 1/2	R.32 TDD	OP.1 TDD	EPA5	2x2 Medium	70	21.7	≥2

8.3.2.2A Enhanced Performance Requirement Type C - Dual-Layer Spatial Multiplexing

The requirements are specified in Table 8.3.2.2A-2, with the addition of the parameters in Table 8.3.2.2A-1 and the downlink physical channel setup according to Annex C.3.2. The purpose of these tests is to verify the rank-2 performance for full RB allocation upon antenna ports 7 and 8.

Table 8.3.2.2A-1: Test Parameters for Testing CDM-multiplexed DM RS (dual layer)

Parameter		Unit	Test 1
Downlink power allocation	ρ_A	dB	0
	ρ_B	dB	0 (Note 1)
	σ	dB	-3
Cell-specific reference symbols			Antenna port 0 and antenna port 1
Beamforming model			Annex B.4.2
N_{oc} at antenna port		dBm/15kHz	-98
Symbols for unused PRBs			OCNG (Note 2)
Number of allocated resource blocks		PRB	50
PDSCH transmission mode			8
Note 1: $P_B = 1$.			
Note 2: These physical resource blocks are assigned to an arbitrary number of virtual UEs with one PDSCH per virtual UE; the data transmitted over the OCNG PDSCHs shall be uncorrelated pseudo random data, which is QPSK modulated.			

Table 8.3.2.2A-2: Enhanced Performance Requirement Type C for CDM-multiplexed DM RS (FRC)

Test number	Bandwidth and MCS	Reference Channel	OCNG Pattern	Propagation Condition	Correlation Matrix and Antenna Configuration	Reference value		UE Category
						Fraction of Maximum Throughput (%)	SNR (dB)	
1	10 MHz 16QAM 1/2	R.32 TDD	OP.1 TDD	EPA5	2x2 Medium	70	17.0	≥2

8.3.2.3 Dual-Layer Spatial Multiplexing (with multiple CSI-RS configurations)

For dual-layer transmission on antenna ports 7 and 8 upon detection of a PDCCH with DCI format 2C, the requirements are specified in Table 8.3.2.3-2, with the addition of the parameters in Table 8.3.2.3-1 where Cell 1 is the serving cell and Cell 2 is the interfering cell. The downlink physical channel setup is set according to Annex C.3.2. The purpose of these tests is to verify the rank-2 performance for full RB allocation, to verify rate matching with multiple CSI reference symbol configurations with non-zero and zero transmission power, and to verify that the UE correctly estimate SNR.

Table 8.3.2.3-1: Test Parameters for Testing CDM-multiplexed DM RS (dual layer) with multiple CSI-RS configurations

Parameter		Unit	Test 1	
			Cell 1	Cell 2
Downlink power allocation	ρ_A	dB	0	0
	ρ_B	dB	0 (Note 1)	0
	σ	dB	-3	-3
	PDSCH_RA	dB	4	N/A
	PDSCH_RB	dB	4	N/A
Cell-specific reference signals			Antenna ports 0 and 1	Antenna ports 0 and 1
Cell ID			0	126
CSI reference signals			Antenna ports 15,16	NA
Beamforming model			Annex B.4.2	NA
CSI-RS periodicity and subframe offset $T_{\text{CSI-RS}} / \Delta_{\text{CSI-RS}}$		Subframes	5 / 4	NA
CSI reference signal configuration			8	NA
Zero-power CSI-RS configuration $l_{\text{CSI-RS}} / \text{ZeroPowerCSI-RS bitmap}$		Subframes / bitmap	4 / 0010000000000000	NA
N_{oc} at antenna port		dBm/15kHz	-98	-98
\hat{E}_s / N_{oc}			Reference Value in Table 8.3.2.3-2	Test specific, 7.25dB
Symbols for unused PRBs			OCNG (Note 2)	NA
Number of allocated resource blocks (Note 2)		PRB	50	NA
Simultaneous transmission			No	NA
PDSCH transmission mode			9	Blanked
Note 1: $P_B = 1$				
Note 2: These physical resource blocks are assigned to an arbitrary number of virtual UEs with one PDSCH per virtual UE; the data transmitted over the OCNG PDSCHs shall be uncorrelated pseudo random data, which is QPSK modulated.				

Table 8.3.2.3-2: Minimum performance for CDM-multiplexed DM RS (FRC) with multiple CSI-RS configurations

Test number	Bandwidth and MCS	Reference Channel	OCNG Pattern		Propagation Condition		Correlation Matrix and Antenna Configuration	Reference value		UE Category
			Cell 1	Cell 2	Cell 1	Cell 2		Fraction of Maximum Throughput (%)	SNR (dB)	
1	10 MHz 16QAM 1/2	R.51 TDD	OP.1 TDD	N/A	ETU5	ETU5	2x2 Low	70	14.8	≥ 2
Note 1: The propagation conditions for Cell 1 and Cell 2 are statistically independent. Note 2: Correlation matrix and antenna configuration parameters apply for each of Cell 1 and Cell 2. Note 3: SNR corresponds to \hat{E}_s / N_{oc} of Cell 1.										

8.3.2.4 Performance requirements for DCI format 2D and non Quasi Co-located Antenna Ports

8.3.2.4.1 Minimum requirement with Same Cell ID (with single NZP CSI-RS resource)

The requirements are specified in Table 8.3.2.4.1-3, with the additional parameters in Table 8.3.2.4.1-1 and Table 8.3.2.4.1-2. The purpose of this test is to verify the UE capability of supporting non quasi-co-located antenna ports when the UE receives DCI format 2D in a scenario where the two transmission point share the same Cell ID. In particular the test verifies that the UE, configured with quasi co-location type B, performs correct tracking and compensation of the timing difference between two transmission points, channel parameters estimation and rate matching according to the ‘PDSCH RE Mapping and Quasi-Co-Location Indicator’ (PQI) signalling defined in [6], configured according to Table 8.3.2.4.1-2. In Tables 8.3.2.4.1-1 and 8.3.2.4.1-2, transmission point 1 (TP 1) is the serving cell and transmission point 2 (TP 2) transmits PDSCH. The downlink physical channel setup for TP 1 is according to Table C.3.4-1 and for TP 2 according to Table C.3.4-2.

Table 8.3.2.4.1-1: Test Parameters for quasi co-location type B: same Cell ID

Parameter		Unit	TP 1	TP 2
Downlink power allocation	ρ_A	dB	0	0
	ρ_B	dB	0 (Note 1)	0
	σ	dB	-3	-3
Cell-specific reference signals			Antenna ports 0,1	(Note 2)
CSI-RS 0 antenna ports			NA	Port {15,16}
<i>qcl-CSI-RS-ConfigNZPId-r11</i> , CSI-RS 0 periodicity and subframe offset $T_{CSI-RS} / \Delta_{CSI-RS}$		Subframes	NA	5/4
<i>qcl-CSI-RS-ConfigNZPId-r11</i> , CSI-RS 0 configuration			NA	8
<i>csi-RS-ConfigZPId-r11</i> , Zero-power CSI-RS 0 configuration $I_{CSI-RS} / \text{ZeroPower CSI-RS bitmap}$			NA	4/ 0000010000000000
N_{oc} at antenna port		dBm/15kHz	-98	-98
\widehat{E}_s / N_{oc}		dB	Reference point in Table 8.3.2.4.1-3	Reference point in Table 8.3.2.4.1-3
BW _{Channel}		MHz	10	10
Cyclic Prefix			Normal	Normal
Cell Id			0	0
Number of control OFDM symbols			2	2
PDSCH transmission mode			Blanked	10
Number of allocated PRB		PRB	NA	50
<i>qcl-Operation</i> , 'PDSCH RE Mapping and Quasi-Co-Location Indicator'			Type B, '00'	
Time offset between TPs		μs	NA	Reference point in Table 8.3.2.4.1-3
Frequency error between TPs		Hz	NA	0
Beamforming model			NA	Port 7 as specified in clause B.4.1
Symbols for unused PRBs			NA	OCNG (Note 3)
Note 1: $P_B = 1$ Note 2: REs for antenna ports 0 and 1 have zero transmission power. Note 3: These physical resource blocks are assigned to an arbitrary number of virtual UEs with one PDSCH per virtual UE; the data transmitted over the OCNG PDSCHs shall be uncorrelated pseudo random data, which is QPSK modulated.				

Table 8.3.2.4.1-2: Configurations of PQI and DL transmission hypothesis for each PQI set

PQI set index	Parameters in each PQI set		DL transmission hypothesis for each PQI Set	
	NZP CSI-RS Index (For quasi co-location)	ZP CSI-RS configuration	TP 1	TP 2
PQI set 0	CSI-RS 0	ZP CSI-RS 0	Blanked	PDSCH

Table 8.3.2.4.1-3: Minimum performance for quasi co-location type B: same Cell ID

Test Number	Reference Channel	OGCN pattern		Time offset between TPs (μ s)	Propagation Conditions (Note1)		Correlation Matrix and Antenna Configuration (Note 2)	Reference Value		UE Category
		TP 1	TP 2		TP 1	TP 2		Fraction of Maximum Throughput (%)	SNR (dB) (Note 3)	
1	R.52 TDD	NA	OP.1 TDD	2	EPA5	EPA5	2x2 Low	70	12	≥ 2
2	R.52 TDD	NA	OP.1 TDD	-0.5	EPA5	EPA5	2x2 Low	70	12.4	≥ 2

Note 1: The propagation conditions for TP 1 and TP 2 are statistically independent.
Note 2: The correlation matrix and antenna configuration apply for TP 1 and TP 2.
Note 3: SNR corresponds to \hat{E}_s / N_{oc} of TP 2 as defined in clause 8.1.1.

8.3.2.4.2 Minimum requirements with Same Cell ID (with multiple NZP CSI-RS resources)

The requirements are specified in Table 8.3.2.4.2-3, with the additional parameters in Tables 8.3.2.4.2-1 and 8.3.2.4.2-2. The purpose of this test is to verify the UE capability of supporting non quasi-co-located antenna ports when the UE receives DCI format 2D in a scenario where the two transmission point share the same Cell ID. In particular the test verifies that the UE, configured with quasi co-location type B, performs correct tracking and compensation of the timing difference between two transmission points, channel parameters estimation and rate matching according to the ‘PDSCH RE Mapping and Quasi-Co-Location Indicator’ (PQI) signalling defined in [6]. In Tables 8.3.2.4.2-1 and 8.3.2.4.2-2, transmission point 1 (TP 1) is the serving cell transmitting PDCCH, synchronization signals and PBCH, and transmission point 2 (TP 2) has same Cell ID as TP 1. Multiple NZP CSI-RS resources and ZP CSI-RS resources are configured. In each sub-frame, DL PDSCH transmission is dynamically switched between 2 TPs with multiple PDSCH RE Mapping and Quasi-Co-Location Indicator configuration (PQI). Configurations of PDSCH RE Mapping and Quasi-Co-Location Indicator and downlink transmission hypothesis are defined in Table 8.3.2.4.2-2. The downlink physical channel setup for TP 1 is according to Table C.3.4-1 and for TP 2 according to Table C.3.4-2.

Table 8.3.2.4.2-1: Test Parameters for timing offset compensation with DPS transmission

parameter	Unit	TP 1	TP 2
Downlink power allocation	ρ_A	dB	0
	ρ_B	dB	0 (Note 1)
	σ	dB	-3

Beamforming model		As specified in clause B.4.1	As specified in clause B.4.1
Cell-specific reference signals		Antenna ports 0,1	(Note 2)
CSI reference signals 0		Antenna ports {15,16}	N/A
CSI-RS 0 periodicity and subframe offset $T_{\text{CSI-RS}} / \Delta_{\text{CSI-RS}}$	Subframes	5 / 4	N/A
CSI reference signal 0 configuration		0	N/A
CSI reference signals 1		N/A	Antenna ports {15,16}
CSI-RS 1 periodicity and subframe offset $T_{\text{CSI-RS}} / \Delta_{\text{CSI-RS}}$	Subframes	N/A	5 / 4
CSI reference signal 1 configuration		N/A	8
Zero-power CSI-RS 0 configuration $l_{\text{CSI-RS}} /$ <i>ZeroPower CSI-RS</i> bitmap	Subframes /bitmap	4/ 0010000000000000	N/A
Zero-power CSI-RS1 configuration $l_{\text{CSI-RS}} /$ <i>ZeroPower CSI-RS</i> bitmaps	Subframes /bitmap	N/A	4/ 0000010000000000
\hat{E}_s / N_{oc}	dB	Reference Value in Table 8.3.2.4.2-3	Reference Value in Table 8.3.2.4.2-3
N_{oc} at antenna port	dBm/15kHz	-98	-98
BW_{Channel}	MHz	10	10
Cyclic Prefix		Normal	Normal
Cell Id		0	0
Number of control OFDM symbols		2	2
Timing offset between TPs		N/A	Reference Value in Table 8.3.2.4.2-3
Frequency offset between TPs	Hz	N/A	0
Number of allocated resource blocks	PRB	50	50
PDSCH transmission mode		10	10
Probability of occurrence of PDSCH transmission(Note 3)	%	30	70
Symbols for unused PRBs		OCNG (Note 4)	OCNG (Note 4)
<p>Note 1: $P_B = 1$</p> <p>Note 2: REs for antenna ports 0 and 1 have zero transmission power.</p> <p>Note 3: PDSCH transmission from TPs shall be randomly determined independently for each subframe. Probabilities of occurrence of PDSCH transmission from TPs are specified.</p> <p>Note 4: These physical resource blocks are assigned to an arbitrary number of virtual UEs with one PDSCH per virtual UE; the data transmitted over the OCNG PDSCHs shall be uncorrelated pseudo random data, which is QPSK modulated.</p>			

Table 8.3.2.4.2-2: Configurations of PQI and DL transmission hypothesis for each PQI set

PQI set index	Parameters in each PQI set		DL transmission hypothesis for each PQI Set	
	NZP CSI-RS Index (For quasi co-location)	ZP CSI-RS configuration	TP 1	TP 2
PQI set 0	CSI-RS 0	ZP CSI-RS 0	PDSCH	Blanked
PQI set 1	CSI-RS 1	ZP CSI-RS 1	Blanked	PDSCH

Table 8.3.2.4.2-3: Performance Requirements for timing offset compensation with DPS transmission

Test Number	Timing offset(us)	Reference Channel	OCNG Pattern		Propagation Conditions		Correlation Matrix and Antenna Configuration (Note 2)	Reference Value		UE Category
			TP 1	TP 2	TP 1	TP 2		Fraction of Maximum Throughput (%)	SNR (dB) (Note 3)	
1	2	R.53 TDD	OP.1 TDD	OP.1 TDD	EPA5	EPA5	2x2 Low	70	12.3	≥2
2	-0.5	R.53 TDD	OP.1 TDD	OP.1 TDD	EPA5	EPA5	2x2 Low	70	12.5	≥2

Note 1: The propagation conditions for TP 1 and TP 2 are statistically independent.
Note 2: Correlation matrix and antenna configuration parameters apply for each of TP 1 and TP 2.
Note 3: SNR corresponds to \hat{E}_s/N_{oc} of both TP 1 and TP 2 as defined in clause 8.1.1.

8.3.2.4.3 Minimum requirement with Different Cell ID and Colliding CRS (with single NZP CSI-RS resource)

The requirements are specified in Table 8.3.2.4.3-2, with the additional parameters in Table 8.3.2.4.3-1. The purpose of this test is to verify the UE capability of supporting non quasi-co-located antenna ports when the UE receives DCI format 2D in a scenario where the two transmission points have different Cell ID and colliding CRS. In particular the test verifies that the UE, configured with quasi co-location type B, performs correct tracking and compensation of the frequency difference between two transmission points, channel parameters estimation and rate matching behaviour according to the 'PDSCH RE Mapping and Quasi-Co-Location Indicator' signalling defined in [6]. In Table 8.3.2.4.3-1, transmission point 1 (TP 1) is serving cell transmitting PDCCH, synchronization signals and PBCH, and transmission point 2 (TP 2) transmits PDSCH with different Cell ID. The downlink physical channel setup for TP 1 is according to Table C.3.4-1 and for TP 2 according to Table C.3.4-2.

Table 8.3.2.4.3-1: Test Parameters for quasi co-location type B with different Cell ID and Colliding CRS

parameter	Unit	TP 1	TP 2
Downlink power allocation	ρ_A	dB	0
	ρ_B	dB	0 (Note 1)
	σ	dB	-3

Beamforming model		N/A	As specified in clause B.4.2
Cell-specific reference signals		Antenna ports 0,1	Antenna ports 0,1
CSI reference signals 0		N/A	Antenna ports {15,16}
CSI-RS 0 periodicity and subframe offset $T_{CSI-RS} / \Delta_{CSI-RS}$	Subframes	N/A	5 / 4
CSI reference signal 0 configuration		N/A	0
Zero-power CSI-RS 0 configuration $I_{CSI-RS} / ZeroPower\ CSI-RS\ bitmap$	Subframes /bitmap	N/A	4/ 0010000000000000
\hat{E}_s / N_{oc}	dB	Reference point in Table 8.3.2.4.3-2 + 4dB	Reference Value in Table 8.3.2.4.3-2
N_{oc} at antenna port	dBm/15kHz	-98	-98
$BW_{Channel}$	MHz	10	10
Cyclic Prefix		Normal	Normal
Cell Id		0	126
Number of control OFDM symbols		1	2
Timing offset between TPs	us	N/A	0
Frequency offset between TPs	Hz	N/A	200
<i>qcl-Operation, PDSCH RE Mapping and Quasi-Co-Location Indicator</i>		Type B, '00'	
PDSCH transmission mode		Blank	10
Number of allocated resource block		N/A	50
Symbols for unused PRBs		N/A	OCNG(Note2)
Note 1: $P_b = 1$ Note 2: These physical resource blocks are assigned to an arbitrary number of virtual UEs with one PDSCH per virtual UE; the data transmitted over the OCNG PDSCHs shall be uncorrelated pseudo random data, which is QPSK modulated.			

Table 8.3.2.4.3-2: Performance Requirements for quasi co-location type B with different Cell ID and Colliding CRS

Test Number	Reference Channel	OCNG Pattern		Propagation Conditions (Note1)		Correlation Matrix and Antenna Configuration (Note 2)	Reference Value		UE Category
		TP 1	TP 2	TP 1	TP 2		Fraction of Maximum Throughput (%)	SNR (dB) (Note 3)	
1	R.54 TDD	N/A	OP.1 TDD	EPA5	ETU5	2x2 Low	70	14.7	≥2
Note 1: The propagation conditions for TP 1 and TP 2 are statistically independent. Note 2: Correlation matrix and antenna configuration parameters apply for each of TP 1 and TP 2. Note 3: SNR corresponds to \hat{E}_s / N_{oc} of TP 2 as defined in clause 8.1.1.									

8.4 Demodulation of PDCCH/PCFICH

The receiver characteristics of the PDCCH/PCFICH are determined by the probability of miss-detection of the Downlink Scheduling Grant (Pm-dsg). PDCCH and PCFICH are tested jointly, i.e. a miss detection of PCFICH implies a miss detection of PDCCH

8.4.1 FDD

The parameters specified in Table 8.4.1-1 are valid for all FDD tests unless otherwise stated.

Table 8.4.1-1: Test Parameters for PDCCH/PCFICH

Parameter		Unit	Single antenna port	Transmit diversity
Number of PDCCH symbols		symbols	2	2
PHICH Ng (Note 1)			1	1
PHICH duration			Normal	Normal
Unused RE-s and PRB-s			OCNG	OCNG
Cell ID			0	0
Downlink power allocation	PDCCH_RA PHICH_RA OCNG_RA	dB	0	-3
	PCFICH_RB PDCCH_RB PHICH_RB OCNG_RB	dB	0	-3
N_{oc} at antenna port		dBm/15kHz	-98	-98
Cyclic prefix			Normal	Normal
Note 1: According to Clause 6.9 in TS 36.211 [4].				

8.4.1.1 Single-antenna port performance

For the parameters specified in Table 8.4.1-1 the average probability of a missed downlink scheduling grant (Pm-dsg) shall be below the specified value in Table 8.4.1.1-1. The downlink physical setup is in accordance with Annex C.3.2.

Table 8.4.1.1-1: Minimum performance PDCCH/PCFICH

Test number	Bandwidth	Aggregation level	Reference Channel	OCNG Pattern	Propagation Condition	Antenna configuration and correlation Matrix	Reference value	
							Pm-dsg (%)	SNR (dB)
1	10 MHz	8 CCE	R.15 FDD	OP.1 FDD	ETU70	1x2 Low	1	-1.7

8.4.1.2 Transmit diversity performance

8.4.1.2.1 Minimum Requirement 2 Tx Antenna Port

For the parameters specified in Table 8.4.1-1 the average probability of a missed downlink scheduling grant (Pm-dsg) shall be below the specified value in Table 8.4.1.2.1-1. The downlink physical setup is in accordance with Annex C.3.2.

Table 8.4.1.2.1-1: Minimum performance PDCCH/PCFICH

Test number	Bandwidth	Aggregation level	Reference Channel	OCNG Pattern	Propagation Condition	Antenna configuration and correlation Matrix	Reference value	
							Pm-dsg (%)	SNR (dB)
1	10 MHz	4 CCE	R.16 FDD	OP.1 FDD	EVA70	2 x 2 Low	1	-0.6

8.4.1.2.2 Minimum Requirement 4 Tx Antenna Port

For the parameters specified in Table 8.4.1-1 the average probability of a missed downlink scheduling grant (Pm-dsg) shall be below the specified value in Table 8.4.1.2.2-1. The downlink physical setup is in accordance with Annex C.3.2.

Table 8.4.1.2.2-1: Minimum performance PDCCH/PCFICH

Test number	Bandwidth	Aggregation level	Reference Channel	OCNG Pattern	Propagation Condition	Antenna configuration and correlation Matrix	Reference value	
							Pm-dsg (%)	SNR (dB)
1	5 MHz	2 CCE	R.17 FDD	OP.1 FDD	EPA5	4 x 2 Medium	1	6.3

8.4.1.2.3 Minimum Requirement 2 Tx Antenna Port (demodulation subframe overlaps with aggressor cell ABS)

For the parameters for non-MBSFN ABS specified in Table 8.4.1-1 and Table 8.4.1.2.3-1, the average probability of a missed downlink scheduling grant (Pm-dsg) shall be below the specified value in Table 8.4.1.2.3-2. The downlink physical setup is in accordance with Annex C.3.2 and Annex C.3.3. In Table 8.4.1.2.3-1, Cell 1 is the serving cell, and Cell 2 is the aggressor cell. The downlink physical channel setup for Cell 1 is according to Annex C.3.2 and for Cell 2 is according to Annex C.3.3, respectively.

For the parameters for MBSFN ABS specified in Table 8.4.1-1 and Table 8.4.1.2.3-3, the average probability of a missed downlink scheduling grant (Pm-dsg) shall be below the specified value in Table 8.4.1.2.3-4. The downlink physical channel setup for Cell 1 is according to Annex C.3.2 and for Cell 2 is according to Annex C.3.3, respectively.

Table 8.4.1.2.3-1: Test Parameters for PDCCH/PCFICH – Non-MBSFN ABS

Parameter		Unit	Cell 1	Cell 2
Downlink power allocation	PDCCH_RA PHICH_RA OCNG_RA	dB	-3	-3
	PCFICH_RB PDCCH_RB PHICH_RB OCNG_RB	dB	-3	-3
N_{oc} at antenna port	N_{oc1}	dBm/15kHz	-100.5 (Note 1)	N/A
	N_{oc2}	dBm/15kHz	-98 (Note 2)	N/A
	N_{oc3}	dBm/15kHz	-95.3 (Note 3)	N/A
\hat{E}_s / N_{oc2}		dB	Reference Value in Table 8.4.1.2.3-2	1.5
BW _{Channel}		MHz	10	10
Subframe Configuration			Non-MBSFN	Non-MBSFN
Time Offset between Cells		μs	2.5 (synchronous cells)	
Cell Id			0	1
ABS pattern (Note 4)			N/A	00000100 00000100 00000100 01000100 00000100
RLM/RRM Measurement Subframe Pattern (Note 5)			00000100 00000100 00000100 00000100	N/A
CSI Subframe Sets (Note 6)	$C_{csi,0}$		00000100 00000100 00000100 01000100 00000100	N/A
	$C_{csi,1}$		11111011 11111011 11111011 10111011 11111011	N/A
Number of control OFDM symbols			3	3
PHICH Ng (Note 9)			1	N/A
PHICH duration			Extended	N/A
Unused RE-s and PRB-s			OCNG	OCNG
Cyclic prefix			Normal	Normal
<p>Note 1: This noise is applied in OFDM symbols #1, #2, #3, #5, #6, #8, #9, #10, #12, #13 of a subframe overlapping with the aggressor ABS.</p> <p>Note 2: This noise is applied in OFDM symbols #0, #4, #7, #11 of a subframe overlapping with the aggressor ABS.</p> <p>Note 3: This noise is applied in all OFDM symbols of a subframe overlapping with aggressor non-ABS</p> <p>Note 4: ABS pattern as defined in [9]. PDCCH/PCFICH other than that associated with SIB1/Paging are transmitted in the serving cell subframe when the subframe is overlapped with the ABS subframe of aggressor cell.</p> <p>Note 5: Time-domain measurement resource restriction pattern for PCell measurements as defined in [7];</p> <p>Note 6: As configured according to the time-domain measurement resource restriction pattern for CSI measurements defined in [7];</p> <p>Note 7: Cell 1 is the serving cell. Cell 2 is the aggressor cell. The number of the CRS ports in Cell1 and Cell2 is the same.</p> <p>Note 8: SIB-1 will not be transmitted in Cell2 in the test.</p> <p>Note 9: According to Clause 6.9 in TS 36.211 [4].</p>				

Table 8.4.1.2.3-2: Minimum performance PDCCH/PCFICH – Non-MBSFN ABS

Test Number	Aggregation Level	Reference Channel	OCNG Pattern		Propagation Conditions (Note 1)		Correlation Matrix and Antenna Configuration	Reference Value	
			Cell 1	Cell 2	Cell 1	Cell 2		Pm-dsg (%)	SNR (dB) (Note 2)
1	8 CCE	R15-1 FDD	OP.1 FDD	OP.1 FDD	EVA5	EVA5	2x2 Low	1	-3.9
Note 1: The propagation conditions for Cell 1 and Cell 2 are statistically independent. Note 2: SNR corresponds to \hat{E}_s / N_{oc2} of cell 1. Note 3: The correlation matrix and antenna configuration apply for Cell 1 and Cell 2.									

Table 8.4.1.2.3-3: Test Parameters for PDCCH/PCFICH – MBSFN ABS

Parameter		Unit	Cell 1	Cell 2
Downlink power allocation	PDCCH_RA PHICH_RA OCNG_RA	dB	-3	-3
	PCFICH_RB PDCCH_RB PHICH_RB OCNG_RB	dB	-3	-3
N_{oc} at antenna port	N_{oc1}	dBm/15kHz	-100.5 (Note 1)	N/A
	N_{oc2}	dBm/15kHz	-98 (Note 2)	N/A
	N_{oc3}	dBm/15kHz	-95.3 (Note 3)	N/A
\hat{E}_s / N_{oc2}		dB	Reference Value in Table 8.4.1.2.3-4	1.5
$BW_{Channel}$		MHz	10	10
Subframe Configuration			Non-MBSFN	MBSFN
Time Offset between Cells		μ s	2.5 (synchronous cells)	
Cell Id			0	126
ABS pattern (Note 4)			N/A	0001000000 0100000010 0000001000 0000000000
RLM/RRM Measurement Subframe Pattern (Note 5)			0001000000 0100000010 0000001000 0000000000	N/A
CSI Subframe Sets (Note 6)	$C_{CSI,0}$		0001000000 0100000010 0000001000 0000000000	N/A
	$C_{CSI,1}$		1110111111 1011111101 1111110111 1111111111	N/A
MBSFN Subframe Allocation (Note 9)			N/A	001000 100001 000100 000000
Number of control OFDM symbols			3	3
PHICH N_g (Note 11)			1	N/A
PHICH duration			extended	N/A
Unused RE-s and PRB-s			OCNG	OCNG
Cyclic prefix			Normal	Normal

Note 1:	This noise is applied in OFDM symbols #1, #2, #3, #4, #5, #6, #7, #8, #9, #10, #11, #12, #13 of a subframe overlapping with the aggressor ABS.
Note 2:	This noise is applied in OFDM symbols #0 of a subframe overlapping with the aggressor ABS.
Note 3:	This noise is applied in all OFDM symbols of a subframe overlapping with aggressor non-ABS
Note 4:	ABS pattern as defined in [9]. The 4 th , 12 th , 19 th and 27 th subframes indicated by ABS pattern are MBSFN ABS subframes. PDSCH other than SIB1/paging and its associated PDCCH/PCFICH are transmitted in the serving cell subframe when the subframe is overlapped with the MBSFN ABS subframe of aggressor cell and the subframe is available in the definition of the reference channel.
Note 5:	Time-domain measurement resource restriction pattern for PCell measurements as defined in [7].
Note 6:	As configured according to the time-domain measurement resource restriction pattern for CSI measurements defined in [7].
Note 7:	Cell 1 is the serving cell. Cell 2 is the aggressor cell. The number of the CRS ports in Cell1 and Cell2 is the same.
Note 8:	SIB-1 will not be transmitted in Cell2 in this test.
Note 9:	MBSFN Subframe Allocation as defined in [7], four frames with 24 bits is chosen for MBSFN subframe allocation.
Note 10:	The maximum number of uplink HARQ transmission is ≤ 2 so that each PHICH channel transmission is in a subframe protected by MBSFN ABS in this test.
Note 11:	According to Clause 6.9 in TS 36.211 [4].

Table 8.4.1.2.3-4: Minimum performance PDCCH/PCHICH – MBSFN ABS

Test Number	Aggregation Level	Reference Channel	OCNG Pattern		Propagation Conditions (Note 1)		Correlation Matrix and Antenna Configuration	Reference Value	
			Cell 1	Cell 2	Cell 1	Cell 2		Pm-dsg (%)	SNR (dB) (Note 2)
1	8 CCE	R15-1 FDD	OP.1 FDD	OP.1 FDD	EVA5	EVA5	2x2 Low	1	-4.2
Note 1: The propagation conditions for Cell 1 and Cell2 are statistically independent. Note 2: SNR corresponds to \hat{E}_s / N_{oc2} of cell 1. Note 3: The correlation matrix and antenna configuration apply for Cell 1 and Cell 2.									

8.4.1.2.4 Minimum Requirement 2 Tx Antenna Port (demodulation subframe overlaps with aggressor cell ABS and CRS assistance information are configured)

For the parameters for non-MBSFN ABS specified in Table 8.4.1-1 and Table 8.4.1.2.4-1, the average probability of a missed downlink scheduling grant (Pm-dsg) shall be below the specified value in Table 8.4.1.2.4-2.

For the parameters for MBSFN ABS specified in Table 8.4.1-1 and Table 8.4.1.2.4-3, the average probability of a missed downlink scheduling grant (Pm-dsg) shall be below the specified value in Table 8.4.1.2.4-4.

In Tables 8.4.1.2.4-1 and 8.4.1.2.4-3, Cell 1 is the serving cell, and Cell 2 and Cell 3 are the aggressor cells. The downlink physical channel setup for Cell 1 is according to Annex C.3.2 and for Cell 2 and Cell 3 is according to Annex C.3.3, respectively. The CRS assistance information [7] including Cell 2 and Cell 3 is provided.

Table 8.4.1.2.4-1: Test Parameters for PDCCH/PCFICH – Non-MBSFN ABS

Parameter		Unit	Cell 1	Cell 2	Cell 3
Downlink power allocation	PDCCH_RA PHICH_RA OCNG_RA	dB	-3	-3	-3
	PCFICH_RB PDCCH_RB PHICH_RB OCNG_RB	dB	-3	-3	-3
N_{oc} at antenna port	N_{oc1}	dBm/15kHz	-98(Note 1)	N/A	N/A
	N_{oc2}	dBm/15kHz	-98 (Note 2)	N/A	N/A
	N_{oc3}	dBm/15kHz	-93 (Note 3)	N/A	N/A
\hat{E}_s / N_{oc2}		dB	Reference Value in Table 8.4.1.2.4-2	5	3
BW _{Channel}		MHz	10	10	10
Subframe Configuration			Non-MBSFN	Non-MBSFN	Non-MBSFN
Time Offset between Cells		μs	N/A	3	-1
Frequency shift between Cells		Hz	N/A	300	-100
Cell Id			0	126	1
ABS pattern (Note 4)			N/A	00000100 00000100 00000100 00000100 00000100	00000100 00000100 00000100 00000100 00000100
RLM/RRM Measurement Subframe Pattern (Note 5)			00000100 00000100 00000100 00000100 00000100	N/A	N/A
CSI Subframe Sets (Note 6)	C _{CSI,0}		00000100 00000100 00000100 00000100 00000100	N/A	N/A
	C _{CSI,1}		11111011 11111011 11111011 11111011 11111011	N/A	N/A
Number of control OFDM symbols			2	Note 7	Note 7
PHICH Ng (Note 10)			1	N/A	N/A
PHICH duration			Normal	N/A	N/A
Unused RE-s and PRB-s			OCNG	OCNG	OCNG
Cyclic prefix			Normal	Normal	Normal

Note 1:	This noise is applied in OFDM symbols #1, #2, #3, #5, #6, #8, #9, #10, #12, #13 of a subframe overlapping with the aggressor ABS.
Note 2:	This noise is applied in OFDM symbols #0, #4, #7, #11 of a subframe overlapping with the aggressor ABS.
Note 3:	This noise is applied in all OFDM symbols of a subframe overlapping with aggressor non-ABS
Note 4:	ABS pattern as defined in [9]. PDCCH/PCFICH other than that associated with SIB1/Paging are transmitted in the serving cell subframe when the subframe is overlapped with the ABS subframe of aggressor cell.
Note 5:	Time-domain measurement resource restriction pattern for PCell measurements as defined in [7];
Note 6:	As configured according to the time-domain measurement resource restriction pattern for CSI measurements defined in [7];
Note 7:	The number of control OFDM symbols is not available for ABS and is 2 for the subframe indicated by "0" of ABS pattern.
Note 8:	The number of the CRS ports in Cell1, Cell2 and Cell 3 is the same.
Note 9:	SIB-1 will not be transmitted in Cell2 and Cell 3 in the test.
Note 10:	According to Clause 6.9 in TS 36.211 [4]

Table 8.4.1.2.4-2: Minimum performance PDCCH/PCFICH – Non-MBSFN ABS

Test Number	Aggregation Level	Reference Channel	OCNG Pattern			Propagation Conditions (Note 1)			Correlation Matrix and Antenna Configuration (Note 2)	Reference Value	
			Cell 1	Cell 2	Cell 3	Cell 1	Cell 2	Cell 3		Pm-dsg (%)	SNR (dB) (Note 3)
1	8 CCE	R.15-2 FDD	OP.1 FDD	OP.1 FDD	OP.1 FDD	EVA5	EVA5	EVA5	2x2 Low	1	-2.2
Note 1: The propagation conditions for Cell 1, Cell 2 and Cell 3 are statistically independent. Note 2: The correlation matrix and antenna configuration apply for Cell 1, Cell 2 and Cell 3. Note 3: SNR corresponds to \hat{E}_s / N_{oc2} of cell 1.											

Table 8.4.1.2.4-3: Test Parameters for PDCCH/PCFICH – MBSFN ABS

Parameter		Unit	Cell 1	Cell 2	Cell 3
Downlink power allocation	PDCCH_RA PHICH_RA OCNG_RA	dB	-3	-3	-3
	PCFICH_RB PDCCH_RB PHICH_RB OCNG_RB	dB	-3	-3	-3
N_{oc} at antenna port	N_{oc1}	dBm/15kHz	-98(Note 1)	N/A	N/A
	N_{oc2}	dBm/15kHz	-98 (Note 2)	N/A	N/A
	N_{oc3}	dBm/15kHz	-93 (Note 3)	N/A	N/A
\hat{E}_s/N_{oc2}		dB	Reference Value in Table 8.4.1.2.4-4	5	3
$BW_{Channel}$		MHz	10	10	10
Subframe Configuration			Non-MBSFN	MBSFN	MBSFN
Time Offset between Cells		μ s	N/A	3	-1
Frequency shift between Cells		Hz	N/A	300	-100
Cell Id			0	126	1
ABS pattern (Note 4)			N/A	0001000000 0100000010 0000001000 0000000000	0001000000 0100000010 0000001000 0000000000
RLM/RRM Measurement Subframe Pattern (Note 5)			0001000000 0100000010 0000001000 0000000000	N/A	N/A
CSI Subframe Sets (Note 6)	$C_{CSI,0}$		0001000000 0100000010 0000001000 0000000000	N/A	N/A
	$C_{CSI,1}$		1110111111 1011111101 1111110111 1111111111	N/A	N/A
MBSFN Subframe Allocation (Note 7)			N/A	001000 100001 000100 000000	001000 100001 000100 000000
Number of control OFDM symbols			2	Note 8	Note 8
PHICH N_g (Note 12)			1	N/A	N/A
PHICH duration			Normal	N/A	N/A
Unused RE-s and PRB-s			OCNG	OCNG	OCNG
Cyclic prefix			Normal	Normal	Normal

Note 1:	This noise is applied in OFDM symbols #1, #2, #3, #4, #5, #6, #7, #8, #9, #10, #11, #12, #13 of a subframe overlapping with the aggressor ABS.
Note 2:	This noise is applied in OFDM symbols #0 of a subframe overlapping with the aggressor ABS.
Note 3:	This noise is applied in all OFDM symbols of a subframe overlapping with aggressor non-ABS ABS pattern as defined in [9]. The 4 th , 12 th , 19 th and 27 th subframes indicated by ABS pattern
Note 4:	are MBSFN ABS subframes. PDSCH other than SIB1/paging and its associated PDCCH/PCFICH are transmitted in the serving cell subframe when the subframe is overlapped with the MBSFN ABS subframe of aggressor cell and the subframe is available in the definition of the reference channel.
Note 5:	Time-domain measurement resource restriction pattern for PCell measurements as defined in [7].
Note 6:	As configured according to the time-domain measurement resource restriction pattern for CSI measurements defined in [7].
Note 7:	MBSFN Subframe Allocation as defined in [7], four frames with 24 bits are chosen for MBSFN subframe allocation.
Note 8:	The number of control OFDM symbols is not available for ABS and is 2 for the subframe indicated by "0" of ABS pattern.
Note 9:	The maximum number of uplink HARQ transmission is ≤ 2 so that each PHICH channel transmission is in a subframe protected by MBSFN ABS in this test.
Note 10:	The number of the CRS ports in Cell 1, Cell 2 and Cell 3 is the same.
Note 11:	SIB-1 will not be transmitted in Cell 2 and Cell 3 in this test.
Note 12:	According to Clause 6.9 in TS 36.211 [4].

Table 8.4.1.2.4-4: Minimum performance PDCCH/PCFICH – MBSFN ABS

Test Number	Aggregation Level	Reference Channel	OCNG Pattern			Propagation Conditions (Note 1)			Correlation Matrix and Antenna Configuration (Note 2)	Reference Value	
			Cell 1	Cell 2	Cell 3	Cell 1	Cell 2	Cell 3		Pm-dsg (%)	SNR (dB) (Note 3)
1	8 CCE	R.15-2 FDD	OP.1 FDD	OP.1 FDD	OP.1 FDD	EVA5	EVA5	EVA5	2x2 Low	1	-2.0
Note 1: The propagation conditions for Cell 1, Cell 2 and Cell 3 are statistically independent. Note 2: The correlation matrix and antenna configuration apply for Cell 1, Cell 2 and Cell 3. Note 3: SNR corresponds to \hat{E}_s / N_{oc2} of cell 1.											

8.4.2 TDD

The parameters specified in Table 8.4.2-1 are valid for all TDD tests unless otherwise stated.

Table 8.4.2-1: Test Parameters for PDCCH/PCFICH

Parameter		Unit	Single antenna port	Transmit diversity
Uplink downlink configuration (Note 1)			0	0
Special subframe configuration (Note 2)			4	4
Number of PDCCH symbols		symbols	2	2
PHICH Ng (Note 3)			1	1
PHICH duration			Normal	Normal
Unused RE-s and PRB-s			OCNG	OCNG
Cell ID			0	0
Downlink power allocation	PDCCH_RA PHICH_RA OCNG_RA	dB	0	-3
	PCFICH_RB PDCCH_RB PHICH_RB OCNG_RB	dB	0	-3
N_{oc} at antenna port		dBm/15kHz	-98	-98
Cyclic prefix			Normal	Normal
ACK/NACK feedback mode			Multiplexing	Multiplexing
Note 1: as specified in Table 4.2-2 in TS 36.211 [4].				
Note 2: as specified in Table 4.2-1 in TS 36.211 [4].				
Note 3: According to Clause 6.9 in TS 36.211 [4].				

8.4.2.1 Single-antenna port performance

For the parameters specified in Table 8.4.2-1 the average probability of a missed downlink scheduling grant (Pm-dsg) shall be below the specified value in Table 8.4.2.1-1. The downlink physical setup is in accordance with Annex C.3.2.

Table 8.4.2.1-1: Minimum performance PDCCH/PCFICH

Test number	Bandwidth	Aggregation level	Reference Channel	OCNG Pattern	Propagation Condition	Antenna configuration and correlation Matrix	Reference value	
							Pm-dsg (%)	SNR (dB)
1	10 MHz	8 CCE	R.15 TDD	OP.1 TDD	ETU70	1x2 Low	1	-1.6

8.4.2.2 Transmit diversity performance

8.4.2.2.1 Minimum Requirement 2 Tx Antenna Port

For the parameters specified in Table 8.4.2-1 the average probability of a missed downlink scheduling grant (Pm-dsg) shall be below the specified value in Table 8.4.2.2.1-1. The downlink physical setup is in accordance with Annex C.3.2.

Table 8.4.2.2.1-1: Minimum performance PDCCH/PCFICH

Test number	Bandwidth	Aggregation level	Reference Channel	OCNG Pattern	Propagation Condition	Antenna configuration and correlation Matrix	Reference value	
							Pm-dsg (%)	SNR (dB)
1	10 MHz	4 CCE	R.16 TDD	OP.1 TDD	EVA70	2 x 2 Low	1	0.1

8.4.2.2.2 Minimum Requirement 4 Tx Antenna Port

For the parameters specified in Table 8.4.2-1 the average probability of a missed downlink scheduling grant (Pm-dsg) shall be below the specified value in Table 8.4.2.2-1. The downlink physical setup is in accordance with Annex C.3.2.

Table 8.4.2.2-1: Minimum performance PDCCH/PCFICH

Test number	Bandwidth	Aggregation level	Reference Channel	OCNG Pattern	Propagation Condition	Antenna configuration and correlation Matrix	Reference value	
							Pm-dsg (%)	SNR (dB)
1	5 MHz	2 CCE	R.17 TDD	OP.1 TDD	EPA5	4 x 2 Medium	1	6.5

8.4.2.2.3 Minimum Requirement 2 Tx Antenna Port (demodulation subframe overlaps with aggressor cell ABS)

For the parameters for non-MBSFN ABS specified in Table 8.4.2-1 and Table 8.4.2.2.3-1, the average probability of a missed downlink scheduling grant (Pm-dsg) shall be below the specified value in Table 8.4.2.2.3-2. The downlink physical setup is in accordance with Annex C.3.2 and Annex C.3.3. In Table 8.4.2.2.3-1, Cell 1 is the serving cell, and Cell 2 is the aggressor cell. The downlink physical channel setup for Cell 1 is according to Annex C.3.2 and for Cell 2 is according to Annex C.3.3, respectively.

For the parameters for MBSFN ABS specified in Table 8.4.2-1 and Table 8.4.2.2.3-3, the average probability of a missed downlink scheduling grant (Pm-dsg) shall be below the specified value in Table 8.4.2.2.3-4. The downlink physical channel setup for Cell 1 is according to Annex C.3.2 and for Cell 2 is according to Annex C.3.3, respectively.

Table 8.4.2.2.3-1: Test Parameters for PDCCH/PCFICH – Non-MBSFN ABS

Parameter		Unit	Cell 1	Cell 2
Uplink downlink configuration			1	1
Special subframe configuration			4	4
Downlink power allocation	PDCCH_RA PHICH_RA OCNG_RA	dB	-3	-3
	PCFICH_RB PDCCH_RB PHICH_RB OCNG_RB	dB	-3	-3
N_{oc} at antenna port	N_{oc1}	dBm/15kHz	-100.5 (Note 1)	N/A
	N_{oc2}	dBm/15kHz	-98 (Note 2)	N/A
	N_{oc3}	dBm/15kHz	-95.3 (Note 3)	N/A
\hat{E}_s / N_{oc2}		dB	Reference Value in Table 8.4.2.2.3-2	1.5
$BW_{Channel}$		MHz	10	10
Subframe Configuration			Non-MBSFN	Non-MBSFN
Time Offset between Cells		μ s	2.5 (synchronous cells)	
Cell Id			0	1
ABS pattern (Note 4)			N/A	0000010001 0000000001
RLM/RRM Measurement Subframe Pattern(Note 5)			0000000001 0000000001	N/A
CSI Subframe Sets(Note 6)	$C_{CSI,0}$		0000010001 0000000001	N/A
	$C_{CSI,1}$		1100101000 1100111000	N/A
Number of control OFDM symbols			3	3
ACK/NACK feedback mode			Multiplexing	N/A
PHICH Ng (Note 9)			1	N/A
PHICH duration			extended	N/A
Unused RE-s and PRB-s			OCNG	OCNG
Cyclic prefix			Normal	Normal
Note 1:	This noise is applied in OFDM symbols #1, #2, #3, #5, #6, #8, #9, #10,#12, #13 of a subframe overlapping with the aggressor ABS.			
Note 2:	This noise is applied in OFDM symbols #0, #4, #7, #11 of a subframe overlapping with the aggressor ABS.			
Note 3:	This noise is applied in OFDM symbols of a subframe overlapping with aggressor non-ABS			
Note 4:	ABS pattern as defined in [9]. PDCCH/PCFICH other than that associated with SIB1/Paging are transmitted in the serving cell subframe when the subframe is overlapped with the ABS subframe of aggressor cell.			
Note 5:	Time-domain measurement resource restriction pattern for PCell measurements as defined in [7].			
Note 6:	As configured according to the time-domain measurement resource restriction pattern for CSI measurements defined in [7].			
Note 7:	Cell 1 is the serving cell. Cell 2 is the aggressor cell. The number of the CRS ports in Cell1 and Cell2 is the same.			
Note 8:	SIB-1 will not be transmitted in Cell2 in the test.			
Note 9:	According to Clause 6.9 in TS 36.211 [4].			

Table 8.4.2.3-2: Minimum performance PDCCH/PCFICH – Non-MBSFN ABS

Test Number	Aggregation Level	Reference Channel	OCNG Pattern		Propagation Conditions (Note 1)		Correlation Matrix and Antenna Configuration	Reference Value	
			Cell 1	Cell 2	Cell 1	Cell 2		Pm-dsg (%)	SNR (dB) (Note 2)
1	8 CCE	R15-1 TDD	OP.1 TDD	OP.1 TDD	EVA5	EVA5	2x2 Low	1	-3.9
Note 1: The propagation conditions for Cell 1 and Cell 2 are statistically independent. Note 2: SNR corresponds to \hat{E}_s / N_{oc2} of cell 1. Note 3: The correlation matrix and antenna configuration apply for Cell 1 and Cell 2.									

Table 8.4.2.2.3-3: Test Parameters for PDCCH/PCFICH – MBSFN ABS

Parameter		Unit	Cell 1	Cell 2
Uplink downlink configuration			1	1
Special subframe configuration			4	4
Downlink power allocation	PDCCH_RA PHICH_RA OCNG_RA	dB	-3	-3
	PCFICH_RB PDCCH_RB PHICH_RB OCNG_RB	dB	-3	-3
N_{oc} at antenna port	N_{oc1}	dBm/15kHz	-100.5 (Note 1)	N/A
	N_{oc2}	dBm/15kHz	-98 (Note 2)	N/A
	N_{oc3}	dBm/15kHz	-95.3 (Note 3)	N/A
\hat{E}_s / N_{oc2}		dB	Reference Value in Table 8.4.2.2.3-4	1.5
$BW_{Channel}$		MHz	10	10
Subframe Configuration			Non-MBSFN	MBSFN
Time Offset between Cells		μ s	2.5 (synchronous cells)	
Cell Id			0	126
ABS pattern (Note 4)			N/A	000000001 000000001
RLM/RRM Measurement Subframe Pattern(Note 5)			000000001 000000001	N/A
CSI Subframe Sets(Note 6)	$C_{CSI,0}$		000000001 000000001	N/A
	$C_{CSI,1}$		1100111000 1100111000	N/A
MBSFN Subframe Allocation (Note 9)			N/A	000010
Number of control OFDM symbols			3	3
ACK/NACK feedback mode			Multiplexing	N/A
PHICH Ng (Note 10)			1	N/A
PHICH duration			extended	N/A
Unused RE-s and PRB-s			OCNG	OCNG
Cyclic prefix			Normal	Normal
<p>Note 1: This noise is applied in OFDM symbols #1, #2, #3, #4, #5, #6, #7, #8, #9, #10, #11, #12, #13 of a subframe overlapping with the aggressor ABS.</p> <p>Note 2: This noise is applied in OFDM symbols #0 of a subframe overlapping with the aggressor ABS.</p> <p>Note 3: This noise is applied in OFDM symbols of a subframe overlapping with aggressor non-ABS</p> <p>Note 4: ABS pattern as defined in [9]. The 10th and 20th subframes indicated by ABS pattern are MBSFN ABS subframes. PDSCH other than SIB1/paging and its associated PDCCH/PCFICH are transmitted in the serving cell subframe when the subframe is overlapped with the MBSFN ABS subframe of aggressor cell and the subframe is available in the definition of the reference channel.</p> <p>Note 5: Time-domain measurement resource restriction pattern for PCell measurements as defined in [7].</p> <p>Note 6: As configured according to the time-domain measurement resource restriction pattern for CSI measurements defined in [7].</p> <p>Note 7: Cell 1 is the serving cell. Cell 2 is the aggressor cell. The number of the CRS ports in Cell1 and Cell2 is the same.</p> <p>Note 8: SIB-1 will not be transmitted in Cell2 in this test.</p> <p>Note 9: MBSFN Subframe Allocation as defined in [7], one frame with 6 bits is chosen for MBSFN subframe allocation.</p> <p>Note 10: According to Clause 6.9 in TS 36.211 [4].</p>				

Table 8.4.2.2.3-4: Minimum performance PDCCH/PCFICH – MBSFN ABS

Test Number	Aggregation Level	Reference Channel	OCNG Pattern		Propagation Conditions(Note 1)		Correlation Matrix and Antenna Configuration	Reference Value	
			Cell 1	Cell 2	Cell 1	Cell 2		Pm-dsg (%)	SNR (dB) (Note 2)
1	8 CCE	R15-1 TDD	OP.1 TDD	OP.1 TDD	EVA5	EVA5	2x2 Low	1	-4.1
Note 1: The propagation conditions for Cell 1 and Cell2 are statistically independent. Note 2: SNR corresponds to \hat{E}_s / N_{oc2} of cell 1. Note 3: The correlation matrix and antenna configuration apply for Cell 1 and Cell 2.									

8.4.2.2.4 Minimum Requirement 2 Tx Antenna Port (demodulation subframe overlaps with aggressor cell ABS and CRS assistance information are configured)

For the parameters for non-MBSFN ABS specified in Table 8.4.2-1 and Table 8.4.2.2.4-1, the average probability of a missed downlink scheduling grant (Pm-dsg) shall be below the specified value in Table 8.4.2.2.4-2.

For the parameters for MBSFN ABS specified in Table 8.4.2-1 and Table 8.4.2.2.4-3, the average probability of a missed downlink scheduling grant (Pm-dsg) shall be below the specified value in Table 8.4.2.2.4-4.

In Tables 8.4.2.2.4-1 and 8.4.2.2.4-3, Cell 1 is the serving cell, and Cell 2 and Cell 3 are the aggressor cells. The downlink physical channel setup for Cell 1 is according to Annex C.3.2 and for Cell 2 and Cell 3 is according to Annex C.3.3, respectively. The CRS assistance information [7] including Cell 2 and Cell 3 is provided.

Table 8.4.2.2.4-1: Test Parameters for PDCCH/PCFICH – Non-MBSFN ABS

Parameter		Unit	Cell 1	Cell 2	Cell 3
Uplink downlink configuration			1	1	1
Special subframe configuration			4	4	4
Downlink power allocation	PDCCH_RA PHICH_RA OCNG_RA	dB	-3	-3	-3
	PCFICH_RB PDCCH_RB PHICH_RB OCNG_RB	dB	-3	-3	-3
N_{oc} at antenna port	N_{oc1}	dBm/15kHz	-98(Note 1)	N/A	N/A
	N_{oc2}	dBm/15kHz	-98 (Note 2)	N/A	N/A
	N_{oc3}	dBm/15kHz	-93 (Note 3)	N/A	N/A
\hat{E}_s / N_{oc2}		dB	Reference Value in Table 8.4.2.2.4-2	5	3
BW _{Channel}		MHz	10	10	10
Subframe Configuration			Non-MBSFN	Non-MBSFN	Non-MBSFN
Time Offset between Cells		μs	N/A	3	-1
Frequency shift between Cells		Hz	N/A	300	-100
Cell Id			0	126	1
ABS pattern (Note 4)			N/A	000000001 000000001	000000001 000000001
RLM/RRM Measurement Subframe Pattern (Note 5)			000000001 000000001	N/A	N/A
CSI Subframe Sets (Note 6)	$C_{CSI,0}$		000000001 000000001	N/A	N/A
	$C_{CSI,1}$		1100111000 1100111000	N/A	N/A
Number of control OFDM symbols			2	Note 7	Note 7
ACK/NACK feedback mode			Multiplexing	N/A	N/A
PHICH Ng (Note 10)			1	N/A	N/A
PHICH duration			Normal	N/A	N/A
Unused RE-s and PRB-s			OCNG	OCNG	OCNG
Cyclic prefix			Normal	Normal	Normal
<p>Note 1: This noise is applied in OFDM symbols #1, #2, #3, #5, #6, #8, #9, #10, #12, #13 of a subframe overlapping with the aggressor ABS.</p> <p>Note 2: This noise is applied in OFDM symbols #0, #4, #7, #11 of a subframe overlapping with the aggressor ABS.</p> <p>Note 3: This noise is applied in all OFDM symbols of a subframe overlapping with aggressor non-ABS</p> <p>Note 4: ABS pattern as defined in [9]. PDCCH/PCFICH other than that associated with SIB1/Paging are transmitted in the serving cell subframe when the subframe is overlapped with the ABS subframe of aggressor cell.</p> <p>Note 5: Time-domain measurement resource restriction pattern for PCell measurements as defined in [7];</p> <p>Note 6: As configured according to the time-domain measurement resource restriction pattern for CSI measurements defined in [7];</p> <p>Note 7: The number of control OFDM symbols is not available for ABS and is 2 for the subframe indicated by "0" of ABS pattern.</p> <p>Note 8: The number of the CRS ports in Cell1, Cell2 and Cell 3 is the same.</p> <p>Note 9: SIB-1 will not be transmitted in Cell2 and Cell 3 in the test.</p> <p>Note 10: According to Clause 6.9 in TS 36.211 [4].</p>					

Table 8.4.2.2.4-2: Minimum performance PDCCH/PCFICH – Non-MBSFN ABS

Test Number	Aggregation Level	Reference Channel	OCNG Pattern			Propagation Conditions (Note 1)			Correlation Matrix and Antenna Configuration (Note 2)	Reference Value	
			Cell 1	Cell 2	Cell 3	Cell 1	Cell 2	Cell 3		Pm-dsg (%)	SNR (dB) (Note 3)
1	8 CCE	R.15-2 TDD	OP.1 TDD	OP.1 TDD	OP.1 TDD	EVA5	EVA5	EVA5	2x2 Low	1	-2.0
Note 1:	The propagation conditions for Cell 1, Cell 2 and Cell 3 are statistically independent.										
Note 2:	The correlation matrix and antenna configuration apply for Cell 1, Cell 2 and Cell 3.										
Note 3:	SNR corresponds to \hat{E}_s / N_{oc2} of cell 1.										

Table 8.4.2.2.4-3: Test Parameters for PDCCH/PCFICH – MBSFN ABS

Parameter		Unit	Cell 1	Cell 2	Cell 3
Uplink downlink configuration			1	1	1
Special subframe configuration			4	4	4
Downlink power allocation	PDCCH_RA PHICH_RA OCNG_RA	dB	-3	-3	-3
	PCFICH_RB PDCCH_RB PHICH_RB OCNG_RB	dB	-3	-3	-3
N_{oc} at antenna port	N_{oc1}	dBm/15kHz	-98 (Note 1)	N/A	N/A
	N_{oc2}	dBm/15kHz	-98 (Note 2)	N/A	N/A
	N_{oc3}	dBm/15kHz	-93 (Note 3)	N/A	N/A
\hat{E}_s / N_{oc2}		dB	Reference Value in Table 8.4.2.2.4-4	5	3
BW _{Channel}		MHz	10	10	10
Subframe Configuration			Non-MBSFN	MBSFN	MBSFN
Time Offset between Cells		μs	N/A	3	-1
Frequency shift between Cells		Hz	N/A	300	-100
Cell Id			0	126	1
ABS pattern (Note 4)			N/A	000000001 000000001	000000001 000000001
RLM/RRM Measurement Subframe Pattern (Note 5)			000000001 000000001	N/A	N/A
CSI Subframe Sets (Note 6)	C _{CSI,0}		000000001 000000001	N/A	N/A
	C _{CSI,1}		1100111000 1100111000	N/A	N/A
MBSFN Subframe Allocation (Note 7)			N/A	000010	000010
Number of control OFDM symbols			2	Note 8	Note 8
ACK/NACK feedback mode			Multiplexing	N/A	N/A
PHICH Ng (Note 11)			1	N/A	N/A
PHICH duration			Normal	N/A	N/A
Unused RE-s and PRB-s			OCNG	OCNG	OCNG
Cyclic prefix			Normal	Normal	Normal
<p>Note 1: This noise is applied in OFDM symbols #1, #2, #3, #4, #5, #6, #7, #8, #9, #10, #11, #12, #13 of a subframe overlapping with the aggressor ABS.</p> <p>Note 2: This noise is applied in OFDM symbols #0 of a subframe overlapping with the aggressor ABS.</p> <p>Note 3: This noise is applied in OFDM symbols of a subframe overlapping with aggressor non-ABS</p> <p>Note 4: ABS pattern as defined in [9]. The 10th and 20th subframes indicated by ABS pattern are MBSFN ABS subframes. PDSCH other than SIB1/paging and its associated PDCCH/PCFICH are transmitted in the serving cell subframe when the subframe is overlapped with the MBSFN ABS subframe of aggressor cell and the subframe is available in the definition of the reference channel.</p> <p>Note 5: Time-domain measurement resource restriction pattern for PCell measurements as defined in [7].</p> <p>Note 6: As configured according to the time-domain measurement resource restriction pattern for CSI measurements defined in [7].</p> <p>Note 7: MBSFN Subframe Allocation as defined in [7], one frame with 6 bits is chosen for MBSFN subframe allocation.</p> <p>Note 8: The number of control OFDM symbols is not available for ABS and is 2 for the subframe indicated by "0" of ABS pattern.</p> <p>Note 9: Cell 1 is the serving cell. Cell 2 is the aggressor cell. The number of the CRS ports in Cell1 and Cell2 is the same.</p> <p>Note 10: SIB-1 will not be transmitted in Cell2 in this test.</p> <p>Note 11: According to Clause 6.9 in TS 36.211 [4].</p>					

Table 8.4.2.2.4-4: Minimum performance PDCCH/PCFICH – MBSFN ABS

Test Number	Aggregation Level	Reference Channel	OCNG Pattern			Propagation Conditions (Note 1)			Correlation Matrix and Antenna Configuration (Note 2)	Reference Value	
			Cell 1	Cell 2	Cell 3	Cell 1	Cell 2	Cell 3		Pm-dsg (%)	SNR (dB) (Note 3)
1	8 CCE	R.15-2 TDD	OP.1 TDD	OP.1 TDD	OP.1 TDD	EVA5	EVA5	EVA5	2x2 Low	1	-1.8

Note 1: The propagation conditions for Cell 1, Cell 2 and Cell 3 are statistically independent.
Note 2: The correlation matrix and antenna configuration apply for Cell 1, Cell 2 and Cell 3.
Note 3: SNR corresponds to \hat{E}_s/N_{oc2} of cell 1.

8.5 Demodulation of PHICH

The receiver characteristics of the PHICH are determined by the probability of miss-detecting an ACK for a NACK (Pm-an). It is assumed that there is no bias applied to the detection of ACK and NACK (zero-threshold detection).

8.5.1 FDD

The parameters specified in Table 8.5.1-1 are valid for all FDD tests unless otherwise stated.

Table 8.5.1-1: Test Parameters for PHICH

Parameter		Unit	Single antenna port	Transmit diversity
Downlink power allocation	PDCCH_RA PHICH_RA OCNG_RA	dB	0	-3
	PCFICH_RB PDCCH_RB PHICH_RB OCNG_RB	dB	0	-3
PHICH duration			Normal	Normal
PHICH Ng (Note 1)			Ng = 1	Ng = 1
PDCCH Content			UL Grant should be included with the proper information aligned with A.3.6.	
Unused RE-s and PRB-s			OCNG	OCNG
Cell ID			0	0
N_{oc} at antenna port		dBm/15kHz	-98	-98
Cyclic prefix			Normal	Normal
Note 1: according to Clause 6.9 in TS 36.211 [4]				

8.5.1.1 Single-antenna port performance

For the parameters specified in Table 8.5.1-1 the average probability of a miss-detecting ACK for NACK (Pm-an) shall be below the specified value in Table 8.5.1.1-1. The downlink physical setup is in accordance with Annex C.3.2.

Table 8.5.1.1-1: Minimum performance PHICH

Test number	Bandwidth	Reference Channel	OCNG Pattern	Propagation Condition	Antenna configuration and correlation Matrix	Reference value	
						Pm-an (%)	SNR (dB)
1	10 MHz	R.18	OP.1 FDD	ETU70	1 x 2 Low	0.1	5.5
2	10 MHz	R.24	OP.1 FDD	ETU70	1 x 2 Low	0.1	0.6

8.5.1.2 Transmit diversity performance

8.5.1.2.1 Minimum Requirement 2 Tx Antenna Port

For the parameters specified in Table 8.5.1-1 the average probability of a miss-detecting ACK for NACK (P_{m-an}) shall be below the specified value in Table 8.5.1.2-1. The downlink physical setup is in accordance with Annex C.3.2.

Table 8.5.1.2.1-1: Minimum performance PHICH

Test number	Bandwidth	Reference Channel	OCNG Pattern	Propagation Condition	Antenna configuration and correlation Matrix	Reference value	
						Pm-an (%)	SNR (dB)
1	10 MHz	R.19	OP.1 FDD	EVA70	2 x 2 Low	0.1	4.4
1A	5MHz (Note 1)	R.19-1	OP.1 FDD	EVA 70	2x2 Low	0.1	4

Note 1: Test case applicability is defined in 8.1.2.1.

8.5.1.2.2 Minimum Requirement 4 Tx Antenna Port

For the parameters specified in Table 8.5.1-1 the average probability of a miss-detecting ACK for NACK (P_{m-an}) shall be below the specified value in Table 8.5.1.2.2-1. The downlink physical setup is in accordance with Annex C.3.2.

Table 8.5.1.2.2-1: Minimum performance PHICH

Test number	Bandwidth	Reference Channel	OCNG Pattern	Propagation Condition	Antenna configuration and correlation Matrix	Reference value	
						Pm-an (%)	SNR (dB)
1	5 MHz	R.20	OP.1 FDD	EPA5	4 x 2 Medium	0.1	6.1

8.5.1.2.3 Minimum Requirement 2 Tx Antenna Port (demodulation subframe overlaps with aggressor cell ABS)

For the parameters specified in Table 8.5.1-1 and Table 8.5.1.2.3-1, the average probability of a miss-detecting ACK for NACK (P_{m-an}) shall be below the specified value in Table 8.5.1.2.3-2. The downlink physical setup is in accordance with Annex C.3.2 and Annex C.3.3. In Table 8.5.1.2.3-1, Cell 1 is the serving cell, and Cell 2 is the aggressor cell. The downlink physical channel setup for Cell 1 is according to Annex C.3.2 and for Cell 2 is according to Annex C.3.3, respectively.

Table 8.5.1.2.3-1: Test Parameters for PHICH

Parameter		Unit	Cell 1	Cell 2
Downlink power allocation	PDCCH_RA PHICH_RA OCNG_RA	dB	-3	-3
	PCFICH_RB PDCCH_RB PHICH_RB OCNG_RB			
N_{oc} at antenna port	N_{oc1}	dBm/15kHz	-100.5 (Note 1)	N/A
	N_{oc2}			
	N_{oc3}			
\hat{E}_s/N_{oc2}		dB	Reference Value in Table 8.5.1.2.3-2	1.5
BW _{Channel}				
Subframe Configuration			Non-MBSFN	Non-MBSFN
Time Offset between Cells		μ s	2.5 (synchronous cells)	
Cell Id			0	1
ABS pattern (Note 4)			N/A	00000100 00000100 00000100 01000100 00000100
RLM/RRM Measurement Subframe Pattern (Note 5)			00000100 00000100 00000100 00000100 00000100	N/A
CSI Subframe Sets (Note 6)	$C_{CSI,0}$		00000100 00000100 00000100 01000100 00000100	N/A
	$C_{CSI,1}$		11111011 11111011 11111011 10111011 11111011	N/A
Number of control OFDM symbols			3	3
PHICH Ng (Note 9)			1	N/A
PHICH duration			extended	N/A
Unused RE-s and PRB-s			OCNG	OCNG
Cyclic prefix			Normal	Normal
<p>Note 1: This noise is applied in OFDM symbols #1, #2, #3, #5, #6, #8, #9, #10, #12, #13 of a subframe overlapping with the aggressor ABS</p> <p>Note 2: This noise is applied in OFDM symbols #0, #4, #7, #11 of a subframe overlapping with the aggressor ABS</p> <p>Note 3: This noise is applied in OFDM symbols of a subframe overlapping with aggressor non-ABS</p> <p>Note 4: ABS pattern as defined in [9]. PHICH is transmitted in the serving cell subframe when the subframe is overlapped with the ABS subframe of aggressor cell but not in the 26th subframe indicated by the ABS pattern.</p> <p>Note 5: Time-domain measurement resource restriction pattern for PCell measurements as defined in [7]</p> <p>Note 6: As configured according to the time-domain measurement resource restriction pattern for CSI measurements defined in [7]</p> <p>Note 7: Cell 1 is the serving cell. Cell 2 is the aggressor cell. The number of the CRS ports in Cell1 and Cell2 is the same.</p> <p>Note 8: SIB-1 will not be transmitted in Cell2 in the test.</p> <p>Note 9: According to Clause 6.9 in TS 36.211 [4].</p>				

Table 8.5.1.2.3-2: Minimum performance PHICH

Test Number	Reference Channel	OCNG Pattern		Propagation Conditions (Note 1)		Antenna Configuration and Correlation Matrix	Reference Value	
		Cell 1	Cell 2	Cell 1	Cell 2		Pm-an (%)	SNR (dB) (Note 2)
1	R.19	OP.1 FDD	OP.1 FDD	EPA5	EPA5	2x2 Low	0.1	4.6
Note 1: The propagation conditions for Cell 1 and Cell 2 are statistically independent. Note 2: SNR corresponds to \hat{E}_s / N_{oc2} of cell 1. Note 3: The correlation matrix and antenna configuration apply for Cell 1 and Cell 2.								

8.5.1.2.4 Minimum Requirement 2 Tx Antenna Port (demodulation subframe overlaps with aggressor cell ABS and CRS assistance information are configured)

For the parameters specified in Table 8.5.1-1 and Table 8.5.1.2.4-1, the average probability of a miss-detecting ACK for NACK (Pm-an) shall be below the specified value in Table 8.5.1.2.4-2. In Table 8.5.1.2.4-1, Cell 1 is the serving cell, and Cell 2 and Cell 3 are the aggressor cells. The downlink physical channel setup for Cell 1 is according to Annex C.3.2 and for Cell 2 and Cell 3 is according to Annex C.3.3, respectively. The CRS assistance information [7] including Cell 2 and Cell 3 is provided.

Table 8.5.1.2.4-1: Test Parameters for PHICH

Parameter		Unit	Cell 1	Cell 2	Cell 3
Downlink power allocation	PDCCH_RA PHICH_RA OCNG_RA	dB	-3	-3	-3
	PCFICH_RB PDCCH_RB PHICH_RB OCNG_RB	dB	-3	-3	-3
N_{oc} at antenna port	N_{oc1}	dBm/15kHz	-98 (Note 1)	N/A	N/A
	N_{oc2}	dBm/15kHz	-98 (Note 2)	N/A	N/A
	N_{oc3}	dBm/15kHz	-93 (Note 3)	N/A	N/A
\hat{E}_s / N_{oc2}		dB	Reference Value in Table 8.5.1.2.4-2	5	3
$BW_{Channel}$		MHz	10	10	10
Subframe Configuration			Non-MBSFN	Non-MBSFN	Non-MBSFN
Time Offset between Cells		μ s	N/A	3	-1
Frequency shift between Cells		Hz	N/A	300	-100
Cell Id			0	126	1
PDCCH Content			UL Grant should be included with the proper information aligned with A.3.6.	N/A	N/A
ABS pattern (Note 4)			N/A	00000100 00000100 00000100 00000100 00000100	00000100 00000100 00000100 00000100 00000100
RLM/RRM Measurement Subframe Pattern (Note 5)			00000100 00000100 00000100 00000100 00000100	N/A	N/A
CSI Subframe Sets (Note 6)	$C_{CSI,0}$		00000100 00000100 00000100 00000100 00000100	N/A	N/A
	$C_{CSI,1}$		11111011 11111011 11111011 11111011 11111011	N/A	N/A
Number of control OFDM symbols			2	Note 7	Note 7
PHICH N_g (Note 10)			1	N/A	N/A
PHICH duration			Normal	N/A	N/A
Unused RE-s and PRB-s			OCNG	OCNG	OCNG
Cyclic prefix			Normal	Normal	Normal

- Note 1: This noise is applied in OFDM symbols #1, #2, #3, #5, #6, #8, #9, #10, #12, #13 of a subframe overlapping with the aggressor ABS
- Note 2: This noise is applied in OFDM symbols #0, #4, #7, #11 of a subframe overlapping with the aggressor ABS
- Note 3: This noise is applied in OFDM symbols of a subframe overlapping with aggressor non-ABS
- Note 4: ABS pattern as defined in [9]. PHICH is transmitted in the serving cell subframe when the subframe is overlapped with the ABS subframe of aggressor cell but not in the 26th subframe indicated by the ABS pattern.
- Note 5: Time-domain measurement resource restriction pattern for PCell measurements as defined in [7]
- Note 6: As configured according to the time-domain measurement resource restriction pattern for CSI measurements defined in [7]
- Note 7: The number of control OFDM symbols is not available for ABS and is 2 for the subframe indicated by "0" of ABS pattern.
- Note 8: The number of the CRS ports in Cell 1, Cell 2 and Cell 3 is the same.
- Note 9: SIB-1 will not be transmitted in Cell 2 and Cell 3 in the test.
- Note 10: According to Clause 6.9 in TS 36.211 [4].

Table 8.5.1.2.4-2: Minimum performance PHICH

Test Number	Reference Channel	OCNG Pattern			Propagation Conditions (Note 1)			Antenna Configuration and Correlation Matrix (Note 2)	Reference Value	
		Cell 1	Cell 2	Cell 3	Cell 1	Cell 2	Cell 3		Pm-an (%)	SNR (dB) (Note 3)
1	R.19	OP.1 FDD	OP.1 FDD	OP.1 FDD	EPA5	EVA5	EVA5	2x2 Low	0.1	5.0

Note 1: The propagation conditions for Cell 1, Cell 2 and Cell 3 are statistically independent.
 Note 2: The correlation matrix and antenna configuration apply for Cell 1, Cell 2 and Cell 3.
 Note 3: SNR corresponds to \hat{E}_s / N_{oc2} of Cell 1.

8.5.2 TDD

The parameters specified in Table 8.5.2-1 are valid for all TDD tests unless otherwise stated.

Table 8.5.2-1: Test Parameters for PHICH

Parameter		Unit	Single antenna port	Transmit diversity
Uplink downlink configuration (Note 1)			1	1
Special subframe configuration (Note 2)			4	4
Downlink power allocation	PDCCH_RA PHICH_RA OCNG_RA	dB	0	-3
	PCFICH_RB PDCCH_RB PHICH_RB OCNG_RB	dB	0	-3
PHICH duration			Normal	Normal
PHICH Ng (Note 3)			Ng = 1	Ng = 1
PDCCH Content			UL Grant should be included with the proper information aligned with A.3.6.	
Unused RE-s and PRB-s			OCNG	OCNG
Cell ID			0	0
N_{oc} at antenna port		dBm/15kHz	-98	-98
Cyclic prefix			Normal	Normal
ACK/NACK feedback mode			Multiplexing	Multiplexing
Note 1: as specified in Table 4.2-2 in TS 36.211 [4]				
Note 2: as specified in Table 4.2-1 in TS 36.211 [4]				
Note 3: according to Clause 6.9 in TS 36.211 [4]				

8.5.2.1 Single-antenna port performance

For the parameters specified in Table 8.5.2-1 the average probability of a miss-detecting ACK for NACK (P_{m-an}) shall be below the specified value in Table 8.5.2.1-1. The downlink physical setup is in accordance with Annex C.3.2.

Table 8.5.2.1-1: Minimum performance PHICH

Test number	Bandwidth	Reference Channel	OCNG Pattern	Propagation Condition	Antenna configuration and correlation Matrix	Reference value	
						P_{m-an} (%)	SNR (dB)
1	10 MHz	R.18	OP.1 TDD	ETU70	1 x 2 Low	0.1	5.8
2	10 MHz	R.24	OP.1 TDD	ETU70	1 x 2 Low	0.1	1.3

8.5.2.2 Transmit diversity performance

8.5.2.2.1 Minimum Requirement 2 Tx Antenna Port

For the parameters specified in Table 8.5.2-1 the average probability of a miss-detecting ACK for NACK (P_{m-an}) shall be below the specified value in Table 8.5.2.2.1-1. The downlink physical setup is in accordance with Annex C.3.2.

Table 8.5.2.2.1-1: Minimum performance PHICH

Test number	Bandwidth	Reference Channel	OCNG Pattern	Propagation Condition	Antenna configuration and correlation Matrix	Reference value	
						Pm-an (%)	SNR (dB)
1	10 MHz	R.19	OP.1 TDD	EVA70	2 x 2 Low	0.1	4.2

8.5.2.2.2 Minimum Requirement 4 Tx Antenna Port

For the parameters specified in Table 8.5.2-1 the average probability of a miss-detecting ACK for NACK (Pm-an) shall be below the specified value in Table 8.5.2.2.2-1. The downlink physical setup is in accordance with Annex C.3.2.

Table 8.5.2.2.2-1: Minimum performance PHICH

Test number	Bandwidth	Reference Channel	OCNG Pattern	Propagation Condition	Antenna configuration and correlation Matrix	Reference value	
						Pm-an (%)	SNR (dB)
1	5 MHz	R.20	OP.1 TDD	EPA5	4 x 2 Medium	0.1	6.2

8.5.2.2.3 Minimum Requirement 2 Tx Antenna Port (demodulation subframe overlaps with aggressor cell ABS)

For the parameters specified in Table 8.5.2-1 and Table 8.5.2.2.3-1, the average probability of a miss-detecting ACK for NACK (Pm-an) shall be below the specified value in Table 8.5.2.2.3-2. The downlink physical setup is in accordance with Annex C.3.2 and Annex C.3.3, In Table 8.5.2.2.3-1, Cell 1 is the serving cell, and Cell 2 is the aggressor cell. The downlink physical channel setup for Cell 1 is according to Annex C.3.2 and for Cell 2 is according to Annex C.3.3, respectively.

Table 8.5.2.2.3-1: Test Parameters for PHICH

Parameter		Unit	Cell 1	Cell 2
Uplink downlink configuration			1	1
Special subframe configuration			4	4
Downlink power allocation	PDCCH_RA PHICH_RA OCNG_RA	dB	-3	-3
	PCFICH_RB PDCCH_RB PHICH_RB OCNG_RB	dB	-3	-3
N_{oc} at antenna port	N_{oc1}	dBm/15kHz	-100.5 (Note 1)	N/A
	N_{oc2}	dBm/15kHz	-98 (Note 2)	N/A
	N_{oc3}	dBm/15kHz	-95.3 (Note 3)	N/A
\hat{E}_s / N_{oc2}		dB	Reference Value in Table 8.5.2.2.3-2	1.5
$BW_{Channel}$		MHz	10	10
Subframe Configuration			Non-MBSFN	Non-MBSFN
Time Offset between Cells		μ s	2.5 (synchronous cells)	
Cell Id			0	1
ABS pattern (Note 4)			N/A	0000010001 0000000001
RLM/RRM Measurement Subframe Pattern (Note 5)			0000000001 0000000001	N/A
CSI Subframe Sets (Note 6)	$C_{CSI,0}$		0000010001 0000000001	N/A
	$C_{CSI,1}$		1100101000 1100111000	N/A
Number of control OFDM symbols			3	3
ACK/NACK feedback mode			Multiplexing	N/A
PHICH N_g (Note 9)			1	N/A
PHICH duration			extended	N/A
Unused RE-s and PRB-s			OCNG	OCNG
Cyclic prefix			Normal	Normal
<p>Note 1: This noise is applied in OFDM symbols #1, #2, #3, #5, #6, #8, #9, #10, #12, #13 of a subframe overlapping with the aggressor ABS</p> <p>Note 2: This noise is applied in OFDM symbols #0, #4, #7, #11 of a subframe overlapping with the aggressor ABS</p> <p>Note 3: This noise is applied in OFDM symbols of a subframe overlapping with aggressor non-ABS</p> <p>Note 4: ABS pattern as defined in [9]. PHICH is transmitted in the serving cell subframe when the subframe is overlapped with the ABS subframe of aggressor cell but not in subframe 5</p> <p>Note 5: Time-domain measurement resource restriction pattern for PCell measurements as defined in [7]</p> <p>Note 6: As configured according to the time-domain measurement resource restriction pattern for CSI measurements defined in [7]</p> <p>Note 7: Cell 1 is the serving cell. Cell 2 is the aggressor cell. The number of the CRS ports in Cell1 and Cell2 is the same.</p> <p>Note 8: SIB-1 will not be transmitted in Cell2 in the test.</p> <p>Note 9: According to Clause 6.9 in TS 36.211 [4].</p>				

Table 8.5.2.2.3-2: Minimum performance PHICH

Test Number	Reference Channel	OCNG Pattern		Propagation Conditions (Note 1)		Antenna Configuration and Correlation Matrix	Reference Value	
		Cell 1	Cell 2	Cell 1	Cell 2		Pm-an (%)	SNR (dB) (Note 2)
1	R.19	OP.1 TDD	OP.1 TDD	EPA5	EPA5	2x2 Low	0.1	4.6
Note 1: The propagation conditions for Cell 1 and Cell 2 are statistically independent. Note 2: SNR corresponds to \hat{E}_s / N_{oc2} of cell 1. Note 3: The correlation matrix and antenna configuration apply for Cell 1 and Cell 2.								

8.5.2.2.4 Minimum Requirement 2 Tx Antenna Port (demodulation subframe overlaps with aggressor cell ABS and CRS assistance information are configured)

For the parameters specified in Table 8.5.2-1 and Table 8.5.2.2.4-1, the average probability of a miss-detecting ACK for NACK (Pm-an) shall be below the specified value in Table 8.5.2.2.4-2. In Table 8.5.2.2.4-1, Cell 1 is the serving cell, and Cell 2 and Cell 3 are the aggressor cells. The downlink physical channel setup for Cell 1 is according to Annex C.3.2 and for Cell 2 and Cell 3 is according to Annex C.3.3, respectively. The CRS assistance information [7] including Cell 2 and Cell 3 is provided.

Table 8.5.2.4-1: Test Parameters for PHICH

Parameter		Unit	Cell 1	Cell 2	Cell 3
Uplink downlink configuration			1	1	1
Special subframe configuration			4	4	4
Downlink power allocation	PDCCH_RA PHICH_RA OCNG_RA	dB	-3	-3	-3
	PCFICH_RB PDCCH_RB PHICH_RB OCNG_RB	dB	-3	-3	-3
N_{oc} at antenna port	N_{oc1}	dBm/15kHz	-98 (Note 1)	N/A	N/A
	N_{oc2}	dBm/15kHz	-98 (Note 2)	N/A	N/A
	N_{oc3}	dBm/15kHz	-93 (Note 3)	N/A	N/A
\hat{E}_s/N_{oc2}		dB	Reference Value in Table 8.5.2.4-2	5	3
$BW_{Channel}$		MHz	10	10	10
Subframe Configuration			Non-MBSFN	Non-MBSFN	Non-MBSFN
Time Offset between Cells		μ s	N/A	3	-1
Frequency shift between Cells		Hz	N/A	300	-100
Cell Id			0	126	1
PDCCH Content			UL Grant should be included with the proper information aligned with A.3.6.	N/A	N/A
ABS pattern (Note 4)			N/A	000000001 000000001	000000001 000000001
RLM/RRM Measurement Subframe Pattern (Note 5)			000000001 000000001	N/A	N/A
CSI Subframe Sets (Note 6)	$C_{CSI,0}$		000000001 000000001	N/A	N/A
	$C_{CSI,1}$		1100111000 1100111000	N/A	N/A
Number of control OFDM symbols			2	Note 7	Note 7
ACK/NACK feedback mode			Multiplexing	N/A	N/A
PHICH N_g (Note 10)			1	N/A	N/A
PHICH duration			Normal	N/A	N/A
Unused RE-s and PRB-s			OCNG	OCNG	OCNG
Cyclic prefix			Normal	Normal	Normal
<p>Note 1: This noise is applied in OFDM symbols #1, #2, #3, #5, #6, #8, #9, #10, #12, #13 of a subframe overlapping with the aggressor ABS</p> <p>Note 2: This noise is applied in OFDM symbols #0, #4, #7, #11 of a subframe overlapping with the aggressor ABS</p> <p>Note 3: This noise is applied in OFDM symbols of a subframe overlapping with aggressor non-ABS</p> <p>Note 4: ABS pattern as defined in [9]. PHICH is transmitted in the serving cell subframe when the subframe is overlapped with the ABS subframe of aggressor cell but not in subframe 5</p> <p>Note 5: Time-domain measurement resource restriction pattern for PCell measurements as defined in [7]</p> <p>Note 6: As configured according to the time-domain measurement resource restriction pattern for CSI measurements defined in [7]</p> <p>Note 7: The number of control OFDM symbols is not available for ABS and is 2 for the subframe indicated by "0" of ABS pattern.</p> <p>Note 8: The number of the CRS ports in Cell 1, Cell 2 and Cell 3 is the same.</p> <p>Note 9: SIB-1 will not be transmitted in Cell 2 and Cell 3 in the test.</p> <p>Note 10: According to Clause 6.9 in TS 36.211 [4].</p>					

Table 8.5.2.2.4-2: Minimum performance PHICH

Test Number	Reference Channel	OCNG Pattern			Propagation Conditions (Note 1)			Antenna Configuration and Correlation Matrix (Note 2)	Reference Value	
		Cell 1	Cell 2	Cell 3	Cell 1	Cell 2	Cell 3		Pm-an (%)	SNR (dB) (Note 3)
1	R.19	OP.1 TDD	OP.1 TDD	OP.1 TDD	EPA5	EVA5	EVA5	2x2 Low	0.1	5.7
Note 1: The propagation conditions for Cell 1, Cell 2 and Cell 3 are statistically independent. Note 2: The correlation matrix and antenna configuration apply for Cell 1, Cell 2 and Cell 3. Note 3: SNR corresponds to \hat{E}_s / N_{oc2} of Cell 1.										

8.6 Demodulation of PBCH

The receiver characteristics of the PBCH are determined by the probability of miss-detection of the PBCH (Pm-bch), which is defined as

$$P_{m-bch} = 1 - \frac{A}{B}$$

Where A is the number of correctly decoded MIB PDUs and B is the Number of transmitted MIB PDUs (Redundancy versions for the same MIB are not counted separately).

8.6.1 FDD

Table 8.6.1-1: Test Parameters for PBCH

Parameter		Unit	Single antenna port	Transmit diversity
Downlink power allocation	PBCH_RA	dB	0	-3
	PBCH_RB	dB	0	-3
N_{oc} at antenna port		dBm/15kHz	-98	-98
Cyclic prefix			Normal	Normal
Cell ID			0	0
Note 1: as specified in Table 4.2-2 in TS 36.211 [4]				
Note 2: as specified in Table 4.2-1 in TS 36.211 [4]				

8.6.1.1 Single-antenna port performance

For the parameters specified in Table 8.6.1-1 the average probability of a miss-detecting PBCH (Pm-bch) shall be below the specified value in Table 8.6.1.1-1. The downlink physical setup is in accordance with Annex C.3.2.

Table 8.6.1.1-1: Minimum performance PBCH

Test number	Bandwidth	Reference Channel	Propagation Condition	Antenna configuration and correlation Matrix	Reference value	
					Pm-bch (%)	SNR (dB)
1	1.4 MHz	R.21	ETU70	1 x 2 Low	1	-6.1

8.6.1.2 Transmit diversity performance

8.6.1.2.1 Minimum Requirement 2 Tx Antenna Port

For the parameters specified in Table 8.6.1-1 the average probability of a miss-detected PBCH (Pm-bch) shall be below the specified value in Table 8.6.1.2.1-1. The downlink physical setup is in accordance with Annex C.3.2.

Table 8.6.1.2.1-1: Minimum performance PBCH

Test number	Bandwidth	Reference Channel	Propagation Condition	Antenna configuration and correlation Matrix	Reference value	
					Pm-bch (%)	SNR (dB)
1	1.4 MHz	R.22	EPA5	2 x 2 Low	1	-4.8

8.6.1.2.2 Minimum Requirement 4 Tx Antenna Port

For the parameters specified in Table 8.6.1-1 the average probability of a miss-detected PBCH (Pm-bch) shall be below the specified value in Table 8.6.1.2.2-1. The downlink physical setup is in accordance with Annex C.3.2.

Table 8.6.1.2.2-1: Minimum performance PBCH

Test number	Bandwidth	Reference Channel	Propagation Condition	Antenna configuration and correlation Matrix	Reference value	
					Pm-bch (%)	SNR (dB)
1	1.4 MHz	R.23	EVA5	4 x 2 Medium	1	-3.5

8.6.1.2.3 Minimum Requirement 2 Tx Antenna Port under Time Domain Measurement Resource Restriction with CRS Assistance Information

For the parameters specified in Table 8.6.1.2.3-1 and Table 8.6.1.2.3-2, the averaged probability of a miss-detected PBCH (Pm-bch) shall be below the specified value in Table 8.6.1.2.3-2. Cell 1 is the serving cell, and Cell 2 and Cell 3 are the aggressor cells. The downlink physical channel setup for Cell 1 is according to Annex C.3.2 and for Cell 2 and Cell 3 is according to Annex C.3.3, respectively. The CRS assistance information [7] including Cell 2 and Cell 3 is provided.

Table 8.6.1.2.3-1: Test Parameters for PBCH

Parameter		Unit	Cell 1	Cell 2	Cell 3
Downlink power allocation	PBCH_RA OCNG_RA	dB	-3	-3	-3
	PBCH_RB OCNG_RB	dB	-3	-3	-3
N_{oc} at antenna port		dBm/15kHz	-98	N/A	N/A
$\frac{E_s}{N_{oc}}$		dB	Reference Value in Table 8.6.1.2.3-2	4	2
BW _{Channel}		MHz	1.4	1.4	1.4
Time Offset between Cells		μs	N/A	3	-1
Frequency shift between Cells		Hz	N/A	300	-100
Cell Id			0	126	1
ABS Pattern (Note 4)			N/A	01000000 01000000 01000000 01000000 01000000	01000000 01000000 01000000 01000000 01000000
Unused RE-s and PRB-s			OCNG	OCNG	OCNG
Cyclic prefix			Normal	Normal	Normal
<p>Note 1: The number of the CRS ports in Cell1, Cell2 and Cell 3 is the same.</p> <p>Note 2: SIB-1 will not be transmitted in Cell2 and Cell 3 in the test.</p> <p>Note 3: The PBCH transmission from Cell 1, Cell 2 and Cell 3 overlap. The same PBCH transmission redundancy version is used for Cell 1, Cell 2 and Cell 3.</p> <p>Note 4: ABS pattern as defined in [9]. PDSCH other than SIB1/paging and its associated PDCCH/PCFICH are transmitted in the serving cell subframe when the subframe is overlapped with the ABS subframe of aggressor cell and the subframe is available in the definition of the reference channel.</p>					

Table 8.6.1.2.3-2: Minimum performance PBCH

Test Number	Reference Channel	Propagation Conditions (Note 1)			Antenna Configuration and Correlation Matrix (Note 2)	Reference Value	
		Cell 1	Cell 2	Cell 3		Pm-bch (%)	SNR (dB) (Note 3)
1	R.22	ETU30	ETU30	ETU30	2x2 Low	1	-3.0
<p>Note 1: The propagation conditions for Cell 1, Cell 2 and Cell 3 are statistically independent.</p> <p>Note 2: The correlation matrix and antenna configuration apply for Cell 1, Cell 2 and Cell 3.</p> <p>Note 3: SNR corresponds to \hat{E}_s / N_{oc} of cell 1.</p>							

8.6.2 TDD

Table 8.6.2-1: Test Parameters for PBCH

Parameter		Unit	Single antenna port	Transmit diversity
Uplink downlink configuration (Note 1)			1	1
Special subframe configuration (Note 2)			4	4
Downlink power allocation	PBCH_RA	dB	0	-3
	PBCH_RB	dB	0	-3
N_{oc} at antenna port		dBm/15kHz	-98	-98
Cyclic prefix			Normal	Normal
Cell ID			0	0
Note 1: as specified in Table 4.2-2 in TS 36.211 [4].				
Note 2: as specified in Table 4.2-1 in TS 36.211 [4].				

8.6.2.1 Single-antenna port performance

For the parameters specified in Table 8.6.2-1 the average probability of a miss-detected PBCH (Pm-bch) shall be below the specified value in Table 8.6.2.1-1. The downlink physical setup is in accordance with Annex C.3.2.

Table 8.6.2.1-1: Minimum performance PBCH

Test number	Bandwidth	Reference Channel	Propagation Condition	Antenna configuration and correlation Matrix	Reference value	
					Pm-bch (%)	SNR (dB)
1	1.4 MHz	R.21	ETU70	1 x 2 Low	1	-6.4

8.6.2.2 Transmit diversity performance

8.6.2.2.1 Minimum Requirement 2 Tx Antenna Port

For the parameters specified in Table 8.6.2-1 the average probability of a miss-detected PBCH (Pm-bch) shall be below the specified value in Table 8.6.2.2.1-1. The downlink physical setup is in accordance with Annex C.3.2.

Table 8.6.2.2.1-1: Minimum performance PBCH

Test number	Bandwidth	Reference Channel	Propagation Condition	Antenna configuration and correlation Matrix	Reference value	
					Pm-bch (%)	SNR (dB)
1	1.4 MHz	R.22	EPA5	2 x 2 Low	1	-4.8

8.6.2.2.2 Minimum Requirement 4 Tx Antenna Port

For the parameters specified in Table 8.6.2-1 the average probability of a miss-detected PBCH (Pm-bch) shall be below the specified value in Table 8.6.2.2.2-1. The downlink physical setup is in accordance with Annex C.3.2.

Table 8.6.2.2-1: Minimum performance PBCH

Test number	Bandwidth	Reference Channel	Propagation Condition	Antenna configuration and correlation Matrix	Reference value	
					Pm-bch (%)	SNR (dB)
1	1.4 MHz	R.23	EVA5	4 x 2 Medium	1	-4.1

8.6.2.2.3 Minimum Requirement 2 Tx Antenna Port under Time Domain Measurement Resource Restriction with CRS Assistance Information

For the parameters specified in Table 8.6.2.2.3-1 and Table 8.6.2.2.3-2, the averaged probability of a miss-detected PBCH (Pm-bch) shall be below the specified value in Table 8.6.2.2.3-2. Cell 1 is the serving cell, and Cell 2 and Cell 3 are the aggressor cells. The downlink physical channel setup for Cell 1 is according to Annex C.3.2 and for Cell 2 and Cell 3 is according to Annex C3.3, respectively. The CRS assistance information [7] including Cell 2 and Cell 3 is provided.

Table 8.6.2.2.3-1: Test Parameters for PBCH

Parameter		Unit	Cell 1	Cell 2	Cell 3
Downlink power allocation	PBCH_RA OCNG_RA	dB	-3	-3	-3
	PBCH_RB OCNG_RB	dB	-3	-3	-3
N_{oc} at antenna port		dBm/15kHz	-98	N/A	N/A
$\frac{\hat{E}_s}{N_{oc}}$		dB	Reference Value in Table 8.6.2.2.3-2	4	2
BW _{Channel}		MHz	1.4	1.4	1.4
Time Offset between Cells		μs	N/A	3	-1
Frequency shift between Cells		Hz	N/A	300	-100
Cell Id			0	126	1
ABS Pattern (Note 4)			N/A	000000001 000000001	000000001 000000001
Unused RE-s and PRB-s			OCNG	OCNG	OCNG
Cyclic prefix			Normal	Normal	Normal
Note 1: The number of the CRS ports in Cell1, Cell2 and Cell 3is the same. Note 2: SIB-1 will not be transmitted in Cell2 and Cell 3 in the test. Note 3: The PBCH transmission from Cell 1, Cell 2 and Cell 3 overlap. The same PBCH transmission redundancy version is used for Cell 1, Cell 2 and Cell 3. Note 4: ABS pattern as defined in [9]. PDSCH other than SIB1/paging and its associated PDCCH/PCFICH are transmitted in the serving cell subframe when the subframe is overlapped with the ABS subframe of aggressor cell and the subframe is available in the definition of the reference channel.					

Table 8.6.2.2.3-2: Minimum performance PBCH

Test Number	Reference Channel	Propagation Conditions (Note 1)			Antenna Configuration and Correlation Matrix (Note 2)	Reference Value	
		Cell 1	Cell 2	Cell 3		Pm-bch (%)	SNR (dB) (Note 3)
1	R.22	ETU30	ETU30	ETU30	2x2 Low	1	-3.0
Note 1: The propagation conditions for Cell 1, Cell 2 and Cell 3 are statistically independent. Note 2: The correlation matrix and antenna configuration apply for Cell 1, Cell 2 and Cell 3. Note 3: SNR corresponds to \hat{E}_s / N_{oc} of cell 1.							

8.7 Sustained downlink data rate provided by lower layers

The purpose of the test is to verify that the Layer 1 and Layer 2 correctly process in a sustained manner the received packets corresponding to the maximum number of DL-SCH transport block bits received within a TTI for the UE category indicated. The sustained downlink data rate shall be verified in terms of the success rate of delivered PDCP SDU(s) by Layer 2. The test case below specifies the RF conditions and the required success rate of delivered TB by Layer 1 to meet the sustained data rate requirement. The size of the TB per TTI corresponds to the largest possible DL-SCH transport block for each UE category using the maximum number of layers for spatial multiplexing. Transmission modes 1 and 3 are used with radio conditions resembling a scenario where sustained maximum data rates are available.

Test case is selected according to table 8.7-1 depending on UE capability for CA and EPDCCH.

Table 8.7-1: SDR test applicability

	Single carrier UE not supporting EPDCCH	CA UE not supporting EPDCCH	Single carrier UE supporting EPDCCH	CA UE supporting EPDCCH
FDD	8.7.1	8.7.1	8.7.3	8.7.1, 8.7.3
TDD	8.7.2	8.7.2	8.7.4	8.7.2, 8.7.4

8.7.1 FDD (single carrier and CA)

The parameters specified in Table 8.7.1-1 are valid for all FDD tests unless otherwise stated.

Table 8.7.1-1: Common Test Parameters (FDD)

Parameter	Unit	Value
Cyclic prefix		Normal
Cell ID		0
Inter-TTI Distance		1
Number of HARQ processes per component carrier	Processes	8
Maximum number of HARQ transmission		4
Redundancy version coding sequence		{0,0,1,2} for 64QAM and 256QAM
Number of OFDM symbols for PDCCH per component carrier	OFDM symbols	1
Cross carrier scheduling		Not configured
Propagation condition		Static propagation condition No external noise sources are applied

For UE not supporting 256QAM, the requirements are specified in Table 8.7.1-3, with the addition of the parameters in Table 8.7.1-2 and the downlink physical channel setup according to Annex C.3.2. The test points are applied to UE category and bandwidth combination with maximum aggregated bandwidth as specified in Table 8.7.1-4. The TB success rate shall be sustained during at least 300 frames.

For UE supporting 256QAM, the requirements are specified in Table 8.7.1-6, with the addition of the parameters in Table 8.7.1-5 and the downlink physical channel setup according to Annex C.3.2. The test points are applied to UE category and bandwidth combination with maximum aggregated bandwidth as specified in Table 8.7.1-7, the TB success rate shall be sustained during at least 300 frames. For UE supporting 256QAM, the requirement in Table 8.7.1-3 is not applicable.

For UE supporting 256QAM and category 9/10 and category 13, the requirements are specified in both Table 8.7.1-3 and Table 8.7.1-6, with the addition of the parameters in Table 8.7.1-2 and in Table 8.7.1-5 respectively. The downlink physical channel setup according to Annex C.3.2. The test points are applied to UE category and bandwidth combination with maximum aggregated bandwidth as specified in Table 8.7.1-4 and in Table 8.7.1-7 for the category 9/10 and category 13, the TB success rate shall be sustained during at least 300 frames.

The test coverage for different number of component carriers is defined in 8.1.2.4.

Table 8.7.1-2: test parameters for sustained downlink data rate (FDD 64QAM)

Test	Bandwidth (MHz)	Transmission mode	Antenna configuration	Codebook subset restriction	Downlink power allocation (dB)			\hat{E}_s at antenna port (dBm/15kHz)	Symbols for unused PRBs
					ρ_A	ρ_B	σ		
1	10	1	1 x 2	N/A	0	0	0	-85	OP.6 FDD
2	10	3	2 x 2	10	-3	-3	0	-85	OP.1 FDD
3,4,6	20	3	2 x 2	10	-3	-3	0	-85	OP.1 FDD
3A	10	3	2 x 2	10	-3	-3	0	-85	OP.1 FDD
3B, 4A	2x10	3	2 x 2	10	-3	-3	0	-85	OP.1 FDD
3C, 4B	15	3	2 x 2	10	-3	-3	0	-85	OP.1 FDD
6A	2x20	3	2 x 2	10	-3	-3	0	-85	OP.1 FDD
6B	10+15	3	2 x 2	10	-3	-3	0	-85	OP.1 FDD
6C	10+20	3	2 x 2	10	-3	-3	0	-85	OP.1 FDD
6D	15+20	3	2 x 2	10	-3	-3	0	-85	OP.1 FDD
6E	2x15	3	2 x 2	10	-3	-3	0	-85	OP.1 FDD
7	3x20	3	2 x 2	10	-3	-3	0	-85	OP.1 FDD
7A	15+20+20	3	2 x 2	10	-3	-3	0	-85	OP.1 FDD
7B	10+20+20	3	2 x 2	10	-3	-3	0	-85	OP.1 FDD
7C	15+15+20	3	2 x 2	10	-3	-3	0	-85	OP.1 FDD
7D	10+15+20	3	2 x 2	10	-3	-3	0	-85	OP.1 FDD
7E	10+10+20	3	2 x 2	10	-3	-3	0	-85	OP.1 FDD
7F	10+15+15	3	2 x 2	10	-3	-3	0	-85	OP.1 FDD
7G	5+10+20	3	2 x 2	10	-3	-3	0	-85	OP.1 FDD

Note 1: For CA test cases, PUCCH format 1b with channel selection is used to feedback ACK/NACK for Test 1-6E, and PUCCH format 3 is used to feedback ACK/NACK for Test 7-7G.

Table 8.7.1-3: Minimum requirement (FDD 64QAM)

Test	Number of bits of a DL-SCH transport block received within a TTI	Measurement channel	Reference value
			TB success rate [%]
1	10296	R.31-1 FDD	95
2	25456	R.31-2 FDD	95
3	51024	R.31-3 FDD	95
3A	36696 (Note 2)	R.31-3A FDD	85
3B	25456	R.31-2 FDD	95
3C	51024	R.31-3C FDD	85
4	75376 (Note 3)	R.31-4 FDD	85
4A	36696 (Note 2)	R.31-3A FDD	85
4B	55056 (Note 5)	R.31-4B FDD	85
6	75376 (Note 3)	R.31-4 FDD	85
6A	75376 (Note 3)	R.31-4 FDD	85
6B	36696 (Note 2) for 10MHz CC 55056 for 15MHz CC	R.31-3A FDD for 10MHz CC R.31-5 FDD for 15MHz CC	85
6C	36696 (Note 2) for 10MHz CC 75376 (Note 3) for 20MHz CC	R.31-3A FDD for 10MHz CC R.31-4 FDD for 20MHz CC	85
6D	55056 for 15MHz CC 75376 (Note 3) for 20MHz CC	R.31-5 FDD for 15MHz CC R.31-4 FDD for 20MHz CC	85
6E	55056 (Note 5) for two 15MHz CCs	R.31-4B FDD for two 15MHz CCs	85
7	75376 (Note 3)	R.31-4 FDD	85
7A	55056 (Note 5) for 15MHz CC 75376 (Note 3) for 20MHz CC	R.31-5 FDD for 15MHz CC R.31-4 FDD for 20MHz CC	85
7B	36696 (Note 2) for 10MHz CC 75376 (Note 3) for 20MHz CC	R.31-3A FDD for 10MHz CC R.31-4 FDD for 20MHz CC	85
7C	55056 (Note 5) for 15MHz CC 75376 (Note 3) for 20MHz CC	R.31-5 FDD for 15MHz CC R.31-4 FDD for 20MHz CC	85
7D	36696 (Note 2) for 10MHz CC 55056 (Note 5) for 15MHz CC 75376 (Note 3) for 20MHz CC	R.31-3A FDD for 10MHz CC R.31-5 FDD for 15MHz CC R.31-4 FDD for 20MHz CC	85
7E	36696 (Note 2) for 10MHz CC 75376 (Note 3) for 20MHz CC	R.31-3A FDD for 10MHz CC R.31-4 FDD for 20MHz CC	85
7F	36696 (Note 2) for 10MHz CC 55056 (Note 5) for 15MHz CC	R.31-3A FDD for 10MHz CC R.31-5 FDD for 15MHz CC	85
7G	18336 (Note 6) for 5MHz CC 36696 (Note 2) for 10MHz CC 75376 (Note 3) for 20MHz CC	R.31-6 FDD for 5MHz CC R.31-3A FDD for 10MHz CC R.31-4 FDD for 20MHz CC	85
Note 1:	For 2 layer transmissions, 2 transport blocks are received within a TTI.		
Note 2:	35160 bits for sub-frame 5.		
Note 3:	71112 bits for sub-frame 5.		
Note 4:	The TB success rate is defined as $TB\ success\ rate = 100\% * N_{DL_correct_rx} / (N_{DL_newtx} + N_{DL_retx})$, where N_{DL_newtx} is the number of newly transmitted DL transport blocks, N_{DL_retx} is the number of retransmitted DL transport blocks, and $N_{DL_correct_rx}$ is the number of correctly received DL transport blocks.		
Note 5:	52752bits for sub-frame 5.		
Note 6:	15840bits for sub-frame 0.		

Table 8.7.1-4: Test points for sustained data rate (FRC 64QAM)

CA config	Maximum supported Bandwidth/ Bandwidth combination (MHz)	Cat. 1	Cat. 2	Cat. 3	Cat. 4	Cat. 6,7	Cat. 9,10	Cat. 11, 12
								DL Cat. 11, 12
Single carrier	10	1	2	3A	3A	-	-	-
	15	-	-	3C	4B	-	-	-
	20	-	-	3	4	6	-	-
CA with 2CCs	10+10	-	-	3B	4A	4A	4A	-
	10+15	-	-	3B	4A	6B	6B	-
	10+20	-	-	3B	4A	6C	6C	-
	15+15	-	-	3B	4A	6E	6E	-
	15+20	-	-	3B	4A	6D	6D	-
	20+20	-	-	3B or 3 (Note 4)	4A or 4 (Note 4)	6A	6A	-
CA with 3CCs	3x20	-	-	-	-	6A	7	7
	15+20+20	-	-	-	-	6A	7A	7A
	10+20+20	-	-	-	-	6A	7B	7B
	15+15+20	-	-	-	-	6D	7C	7C
	10+15+20	-	-	-	-	6D	7D	7D
	10+10+20	-	-	-	-	7E	7E	7E
	10+15+15	-	-	-	-	7F	7F	7F
5+10+20	-	-	-	-	7G	7G	7G	
Note 1: Void. Note 2: For non-CA UE, test is selected for maximum supported bandwidth. Note 3: Void. Note 4: If the intra-band contiguous CA is the only CA configuration supported by category 3 or 4 UE, the single carrier test is selected, i.e., Test 3 for UE category 3 and Test 4 for UE category 4. Otherwise, Test 3B applies for category 3 UE and Test 4A applies for category 4 UE. Note 5: The applicability of requirements for different CA configurations and bandwidth combination sets is defined in 8.1.2.3.								

Table 8.7.1-5: test parameters for sustained downlink data rate (FDD 256QAM)

Test	Bandwidth (MHz)	Transmission mode	Antenna configuration	Codebook subset restriction	Downlink power allocation (dB)			\hat{E}_s at antenna port (dBm/15kHz)	Symbols for unused PRBs
					ρ_A	ρ_B	σ		
1	20	3	2 x 2	10	-3	-3	0	-85	OP.1 FDD
2	2x10	3	2 x 2	10	-3	-3	0	-85	OP.1 FDD
3	10+15	3	2 x 2	10	-3	-3	0	-85	OP.1 FDD
4	10+20	3	2 x 2	10	-3	-3	0	-85	OP.1 FDD
5	2x15	3	2 x 2	10	-3	-3	0	-85	OP.1 FDD
6	15+20	3	2 x 2	10	-3	-3	0	-85	OP.1 FDD
7	2x20	3	2 x 2	10	-3	-3	0	-85	OP.1 FDD
8	3x20	3	2 x 2	10	-3	-3	0	-85	OP.1 FDD
9	15+20+20	3	2 x 2	10	-3	-3	0	-85	OP.1 FDD
10	10+20+20	3	2 x 2	10	-3	-3	0	-85	OP.1 FDD
11	15+15+20	3	2 x 2	10	-3	-3	0	-85	OP.1 FDD
12	10+15+20	3	2 x 2	10	-3	-3	0	-85	OP.1 FDD
13	10+10+20	3	2 x 2	10	-3	-3	0	-85	OP.1 FDD
14	10+15+15	3	2 x 2	10	-3	-3	0	-85	OP.1 FDD
15	5+10+20	3	2 x 2	10	-3	-3	0	-85	OP.1 FDD
Note 1: For CA test cases, PUCCH format 3 is used to feedback ACK/NACK.									

Table 8.7.1-6: Minimum requirement (FDD 256QAM)

Test	Measurement channel	Reference value
		TB success rate [%]
1	R.68 FDD	85
2	R.68-2 FDD	85
3	R.68-2 FDD for 10MHz CC R.68-1 FDD for 15MHz CC	85
4	R.68-2 FDD for 10MHz CC R.68 FDD for 20MHz CC	85
5	R.68-1 FDD	85
6	R.68-1 FDD for 15MHz CC R.68 FDD for 20MHz CC	85
7	R.68 FDD	85
8	R.68 FDD	85
9	R.68-1 FDD for 15MHz CC R.68 FDD for 20MHz CC	85
10	R.68-2 FDD for 10MHz CC R.68 FDD for 20MHz CC	85
11	R.68-1 FDD for 15MHz CC R.68 FDD for 20MHz CC	85
12	R.68-2 FDD for 10MHz CC R.68-1 FDD for 15MHz CC R.68 FDD for 20MHz CC	85
13	R.68-2 FDD for 10MHz CC R.68 FDD for 20MHz CC	85
14	R.68-2 FDD for 10MHz CC R.68-1 FDD for 15MHz CC	85
15	R.68-3 FDD for 5MHz CC R.68-2 FDD for 10MHz CC R.68 FDD for 20MHz CC	85
Note 1:	For 2 layer transmissions, 2 transport blocks are received within a TTI.	
Note 2:	The TB success rate is defined as TB success rate = $100\% \cdot N_{DL_correct_rx} / (N_{DL_newtx} + N_{DL_retx})$, where N_{DL_newtx} is the number of newly transmitted DL transport blocks, N_{DL_retx} is the number of retransmitted DL transport blocks, and $N_{DL_correct_rx}$ is the number of correctly received DL transport blocks.	

Table 8.7.1-7: Test points for sustained data rate (FRC 256QAM)

CA config	Maximum supported Bandwidth/ Bandwidth combination (MHz)	Cat. 11, 12	DL Cat. 13				
		DL Cat. 11, 12					
Single carrier	20	-	1				
CA with 2CCs	2x10	2	2				
	10+15	3	3				
	10+20	4	4				
	2x15	5	5				
	15+20	6	6				
	20+20	7	7				
CA with 3CCs	3x20	8	7				
	15+20+20	9	7				
	10+20+20	10	7				
	15+15+20	11	6				
	10+15+20	12	6				
	10+10+20	13	13				
	10+15+15	14	14				
	5+10+20	15	15				

8.7.2 TDD (single carrier and CA)

The parameters specified in Table 8.7.2-1 are valid for all TDD tests unless otherwise stated.

Table 8.7.2-1: Common Test Parameters (TDD)

Parameter	Unit	Value
Special subframe configuration (Note 1)		4
Cyclic prefix		Normal
Cell ID		0
Inter-TTI Distance		1
Maximum number of HARQ transmission		4
Redundancy version coding sequence		{0,0,1,2} for 64QAM and 256QAM
Number of OFDM symbols for PDCCH per component carrier	OFDM symbols	1
Cross carrier scheduling		Not configured
Propagation condition		Static propagation condition No external noise sources are applied
Note 1: as specified in Table 4.2-1 in TS 36.211 [4].		

For UE not supporting 256QAM, the requirements are specified in Table 8.7.2-3, with the addition of the parameters in Table 8.7.2-2 and the downlink physical channel setup according to Annex C.3.2. The test points are applied to UE category and bandwidth combination with maximum aggregated bandwidth as specified in Table 8.7.2-4. The TB success rate shall be sustained during at least 300 frames.

For UE supporting 256QAM, the requirements are specified in Table 8.7.2-6, with the addition of the parameters in Table 8.7.2-5 and the downlink physical channel setup according to Annex C.3.2. The test points are applied to UE category and bandwidth combination with maximum aggregated bandwidth as specified in Table 8.7.2-7. The TB success rate shall be sustained during at least 300 frames. For UE supporting 256QAM, the requirement in Table 8.7.2-3 is not applicable.

For UE supporting 256QAM and category 9/10 and category 13, the requirements are specified in both Table 8.7.2-3 and Table 8.7.2-6, with the addition of the parameters in Table 8.7.2-2 and in Table 8.7.2-5 respectively. The downlink physical channel setup according to Annex C.3.2. The test points are applied to UE category and bandwidth combination with maximum aggregated bandwidth as specified in Table 8.7.2-4 and in Table 8.7.2-7 for the category 9/10 and category 13, the TB success rate shall be sustained during at least 300 frames.

The test coverage for different number of component carriers is defined in 8.1.2.4.

Table 8.7.2-2: test parameters for sustained downlink data rate (TDD 64QAM)

Test	Bandwidth (MHz)	Transmission mode	Antenna configuration	Codebook subset restriction	Downlink power allocation (dB)			\hat{E}_s at antenna port (dBm/15 kHz)	ACK/NACK feedback mode	Symbols for unused PRBs
					ρ_A	ρ_B	σ			
1	10	1	1 x 2	N/A	0	0	0	-85	Bundling	OP.6 TDD
2	10	3	2 x 2	10	-3	-3	0	-85	Bundling	OP.1 TDD
3	20	3	2 x 2	10	-3	-3	0	-85	Bundling	OP.1 TDD
3A	15	3	2 x 2	10	-3	-3	0	-85	Multiplexing	OP.2 TDD
4,6	20	3	2 x 2	10	-3	-3	0	-85	Multiplexing	OP.1 TDD
6A	2x20	3	2 x 2	10	-3	-3	0	-85	- (Note 1)	OP.1 TDD
6B	20+15	3	2 x 2	10	-3	-3	0	-85	(Note 1)	OP.1 TDD
7	3x20	3	2 x 2	10	-3	-3	0	-85	(Note 2)	OP.1 TDD
7A	15+20+20	3	2 x 2	10	-3	-3	0	-85	(Note 2)	OP.1 TDD

Note 1: PUCCH format 1b with channel selection is used to feedback ACK/NACK.
Note 2: PUCCH format 3 is used to feedback ACK/NACK.

Table 8.7.2-3: Minimum requirement (TDD 64QAM)

Test	Number of bits of a DL-SCH transport block received within a TTI for normal/special sub-frame	Measurement channel	Reference value
			TB success rate [%]
1	10296/0	R31-1 TDD	95
2	25456/0	R31-2 TDD	95
3	51024/0	R31-3 TDD	95
3A	51024/0	R31-3A TDD	85
4	75376/0 (Note 2)	R31-4 TDD	85
6	75376/0 (Note 2)	R.31-4 TDD	85
6A	75376/0 (Note 2)	R.31-4 TDD	85
6B	55056/0 for 15MHz CC 75376/0 for 20MHz CC (Note 2)	R31-5 TDD for 15MHz CC R.31-4 TDD for 20MHz CC	85
7	75376/0 (Note 2)	R.31-4 TDD	85
7A	55056/0 for 15MHz CC 75376/0 for 20MHz CC (Note 2)	R.31-5 TDD for 15MHz CC R.31-4 TDD for 20MHz CC	85

Note 1: For 2 layer transmissions, 2 transport blocks are received within a TTI.
Note 2: 71112 bits for sub-frame 5.
Note 3: The TB success rate is defined as TB success rate = 100% * $N_{DL_correct_rx} / (N_{DL_newtx} + N_{DL_retx})$, where N_{DL_newtx} is the number of newly transmitted DL transport blocks, N_{DL_retx} is the number of retransmitted DL transport blocks, and $N_{DL_correct_rx}$ is the number of correctly received DL transport blocks.

Table 8.7.2-4: Test points for sustained data rate (FRC 64QAM)

CA config	Bandwidth/ Bandwidth combination (MHz)	Cat. 1	Cat. 2	Cat. 3	Cat. 4	Cat. 6,7	Cat. 9, 10	Cat. 11, 12
								DL Cat. 11, 12
Single carrier	10	1	2	-	-	-	-	-
	15	-	-	3A	3A	-	-	-
	20	-	-	3	4	6	-	-
CA with 2CCs	20+20	-	--	3(Note 4)	4 (Note 4)	6A	6A	-
	15+20	-	-	3(Note 4)	4 (Note 4)	6B	6B	-
CA with 3 CCs	3x20	-	-	-	-	6A	7	7
	15+20+20	-	-	-	-	6A	7A	7A
Note 1: Void. Note 2: For non-CA UE, test is selected for maximum supported bandwidth. Note 3: Void. Note 4: If the intra-band contiguous CA is the only CA configuration supported by category 3 or 4 UE, single carrier test is selected. Note 5: The applicability of requirements for different CA configurations and bandwidth combination sets is defined in 8.1.2.3.								

Table 8.7.2-5: test parameters for sustained downlink data rate (TDD 256QAM)

Test	Bandwidth (MHz)	Transmission mode	Antenna configuration	Codebook subset restriction	Downlink power allocation (dB)			\hat{E}_s at antenna port (dBm/15 kHz)	ACK/NACK feedback mode	Symbols for unused PRBs
					ρ_A	ρ_B	σ			
1	20	3	2 x 2	10	-3	-3	0	-85	Bundling	OP.1 TDD
2	15+20	3	2 x 2	10	-3	-3	0	-85	(Note 1)	OP.1 TDD
3	2x20	3	2 x 2	10	-3	-3	0	-85	(Note 1)	OP.1 TDD
4	3x20	3	2 x 2	10	-3	-3	0	-85	(Note 1)	OP.1 TDD
5	15+20+20	3	2 x 2	10	-3	-3	0	-85	(Note 1)	OP.1 TDD
Note 1: For CA test cases, PUCCH format 3 is used to feedback ACK/NACK.										

Table 8.7.2-6: Minimum requirement (TDD 256QAM)

Test	Measurement channel	Reference value
		TB success rate [%]
1	R.68 TDD	85
2	R.68-1 TDD for 15MHz CC R.68 TDD for 20MHz CC	85
3	R.68 TDD	85
4	R.68 TDD	85
5	R.68-1 TDD for 15MHz CC R.68 TDD for 20MHz CC	85
Note 1: For 2 layer transmissions, 2 transport blocks are received within a TTI. Note 2: The TB success rate is defined as TB success rate = $100\% \cdot N_{DL_correct_rx} / (N_{DL_newtx} + N_{DL_retx})$, where N_{DL_newtx} is the number of newly transmitted DL transport blocks, N_{DL_retx} is the number of retransmitted DL transport blocks, and $N_{DL_correct_rx}$ is the number of correctly received DL transport blocks.		

Table 8.7.2-7: Test points for sustained data rate (FRC 256QAM)

CA config	Bandwidth/ Bandwidth combination (MHz)	Cat. 11, 12	DL Cat. 13				
		DL Cat. 11, 12					
Single carrier	20	-	1				
CA with 2CCs	15+20	2	2				
	2x20	3	3				
CA with 3 CCs	3x20	4	3				
	15+20+20	5	3				

8.7.3 FDD (EPDCCH scheduling)

The parameters specified in Table 8.7.3-1 are valid for all FDD tests unless otherwise stated.

Table 8.7.3-1: Common test parameters (FDD)

Parameter	Unit	Value
Cyclic prefix		Normal
Cell ID		0
Inter-TTI Distance		1
Number of HARQ processes per component carrier	Processes	8
Maximum number of HARQ transmission		4
Redundancy version coding sequence		{0,0,1,2} for 64QAM
Number of OFDM symbols for PDCCH per component carrier	OFDM symbols	1
Cross carrier scheduling		Not configured
Number of EPDCCH sets		1
EPDCCH transmission type		Localized
Number of PRB per EPDCCH set and EPDCCH PRB pair allocation		2 PRB pairs 10MHz BW: Resource blocks $n_{PRB} = 48, 49$ 15MHz BW: Resource blocks $n_{PRB} = 70, 71$ 20MHz BW: Resource blocks $n_{PRB} = 98, 99$
EPDCCH Starting Symbol		Derived from CFI (i.e. default behaviour)
ECCE Aggregation Level		2 ECCEs
Number of EREGs per ECCE		4
EPDCCH scheduling		EPDCCH candidate is randomly assigned in each subframe
EPDCCH precoder (Note 1)		Fixed PMI 0
EPDCCH monitoring SF pattern		1111111111 0000000000 1111111111 0000000000
Timing advance	μ s	100
Propagation condition		Static propagation condition No external noise sources are applied
Note 1:	EPDCCH precoder parameters are defined for tests with 2 x 2 antenna configuration	

The requirements are specified in Table 8.7.3-3, with the addition of the parameters in Table 8.7.3-2 and the downlink physical channel setup according to Annex C.3.2. The test points are applied to UE category, CA capability and

bandwidth combination with maximum aggregated bandwidth as specified in Table 8.7.3-4. The TB success rate shall be sustained during at least 300 frames.

Table 8.7.3-2: Test parameters for SDR test for PDSCH scheduled by EPDCCH (FDD)

Test	Bandwidth (MHz)	Transmission mode	Antenna configuration	Codebook subset restriction	Downlink power allocation (dB)				\hat{E}_s at antenna port (dBm/15kHz)	Symbols for unused PRBs
					ρ_A	ρ_B	σ	δ		
1	10	1	1 x 2	N/A	0	0	0	0	-85	OP.6 FDD
2	10	3	2 x 2	10	-3	-3	0	3	-85	OP.1 FDD
3,4,6	20	3	2 x 2	10	-3	-3	0	3	-85	OP.1 FDD
3A	10	3	2 x 2	10	-3	-3	0	3	-85	OP.1 FDD
3C, 4B	15	3	2 x 2	10	-3	-3	0	3	-85	OP.1 FDD

Table 8.7.3-3: Minimum requirement (FDD)

Test	Number of bits of a DL-SCH transport block received within a TTI	Measurement channel	Reference value
			TB success rate [%]
1	10296	R.31E-1 FDD	95
2	25456	R.31E-2 FDD	95
3	51024	R.31E-3 FDD	95
3A	36696 (Note 2)	R.31E-3A FDD	85
3C	51024	R.31E-3C FDD	85
4	75376 (Note 3)	R.31E-4 FDD	85
4B	55056 (Note 5)	R.31E-4B FDD	85
6	75376 (Note 3)	R.31E-4 FDD	85

Note 1: For 2 layer transmissions, 2 transport blocks are received within a TTI.
Note 2: 35160 bits for sub-frame 5.
Note 3: 71112 bits for sub-frame 5.
Note 4: The TB success rate is defined as TB success rate = 100% * $N_{DL_correct_rx} / (N_{DL_newtx} + N_{DL_retx})$, where N_{DL_newtx} is the number of newly transmitted DL transport blocks, N_{DL_retx} is the number of retransmitted DL transport blocks, and $N_{DL_correct_rx}$ is the number of correctly received DL transport blocks.
Note 5: 52752 bits for sub-frame 5.

Table 8.7.3-4: Test points for sustained data rate (FRC)

CA config	Bandwidth (MHz)	Category 1	Category 2	Category 3	Category 4	Category 6	Category 7
Single carrier	10	1	2	3A	3A	-	-
	15	-	-	3C	4B	-	-
	20	-	-	3	4	6	6

Note 1: The test is selected for maximum supported bandwidth.

8.7.4 TDD (EPDCCH scheduling)

The parameters specified in Table 8.7.4-1 are valid for all TDD tests unless otherwise stated.

Table 8.7.4-1: Common test parameters (TDD)

Parameter	Unit	Value
Special subframe configuration (Note 1)		4
Cyclic prefix		Normal
Cell ID		0
Inter-TTI Distance		1
Maximum number of HARQ transmission		4
Redundancy version coding sequence		{0,0,1,2} for 64QAM
Number of OFDM symbols for PDCCH per component carrier	OFDM symbols	1
Cross carrier scheduling		Not configured
Number of EPDCCH sets		1
EPDCCH transmission type		Localized
Number of PRB per EPDCCH set and EPDCCH PRB pair allocation		2 PRB pairs 10MHz BW: Resource blocks $n_{PRB} = 48, 49$ 15MHz BW: Resource blocks $n_{PRB} = 70, 71$ 20MHz BW: Resource blocks $n_{PRB} = 98, 99$
EPDCCH Starting Symbol		Derived from CFI (i.e. default behaviour)
ECCE Aggregation Level		2 ECCEs
Number of EREGs per ECCE		4 for normal subframe and for special subframe
EPDCCH scheduling		EPDCCH candidate is randomly assigned in each subframe
EPDCCH precoder (Note 2)		Fixed PMI 0
EPDCCH monitoring SF pattern		UL-DL configuration 1: 110111111 000000000 UL-DL configuration 5: 1100111001 000000000
Timing advance	μs	100
Propagation condition		Static propagation condition No external noise sources are applied
Note 1:	As specified in Table 4.2-1 in TS 36.211 [4].	
Note 2:	EPDCCH precoder parameters are defined for tests with 2 x 2 antenna configuration	

The requirements are specified in Table 8.7.4-3, with the addition of the parameters in Table 8.7.4-2 and the downlink physical channel setup according to Annex C.3.2. The test points are applied to UE category, CA capability and bandwidth combination with maximum aggregated bandwidth as specified in Table 8.7.4-4. The TB success rate shall be sustained during at least 300 frames.

Table 8.7.4-2: Test parameters for SDR test for PDSCH scheduled by EPDCCH (TDD)

Test	Bandwidth (MHz)	Transmission mode	Antenna configuration	Codebook subset restriction	Downlink power allocation (dB)				\hat{E}_s at antenna port (dBm/15kHz)	Symbols for unused PRBs	ACK/NACK feedback mode
					ρ_A	ρ_B	σ	δ			
1	10	1	1 x 2	N/A	0	0	0	0	-85	OP.6 TDD	Bundling
2	10	3	2 x 2	10	-3	-3	0	3	-85	OP.1 TDD	Bundling
3	20	3	2 x 2	10	-3	-3	0	3	-85	OP.1 TDD	Bundling
3A	15	3	2 x 2	10	-3	-3	0	3	-85	OP.2 TDD	Multiplexing
4,6	20	3	2 x 2	10	-3	-3	0	3	-85	OP.1 TDD	Multiplexing

Table 8.7.4-3: Minimum requirement (TDD)

Test	Number of bits of a DL-SCH transport block received within a TTI for normal/special sub-frame	Measurement channel	Reference value
			TB success rate [%]
1	10296/0	R.31E-1 TDD	95
2	25456/0	R.31E-2 TDD	95
3	51024/0	R.31E-3 TDD	95
3A	51024/0	R.31E-3A TDD	85
4	75376/0 (Note 2)	R.31E-4 TDD	85
6	75376/0 (Note 2)	R.31E-4 TDD	85

Note 1: For 2 layer transmissions, 2 transport blocks are received within a TTI.
Note 2: 71112 bits for sub-frame 5.
Note 3: The TB success rate is defined as TB success rate = 100% * $N_{DL_correct_rx} / (N_{DL_newtx} + N_{DL_retx})$, where N_{DL_newtx} is the number of newly transmitted DL transport blocks, N_{DL_retx} is the number of retransmitted DL transport blocks, and $N_{DL_correct_rx}$ is the number of correctly received DL transport blocks.

Table 8.7.4-4: Test points for sustained data rate (FRC)

CA config	Bandwidth/ Bandwidth combination (MHz)	Category 1	Category 2	Category 3	Category 4	Category 6	Category 7
Single carrier	10	1	2	-	-	-	-
	15	-	-	3A	3A	-	-
	20	-	-	3	4	6	6

Note 1: The test is selected for maximum supported bandwidth.

8.7.5 TDD FDD CA

The parameters specified in Table 8.7.5-1 are valid for all TDD FDD CA tests unless otherwise stated.

Table 8.7.5-1: Common Test Parameters (TDD FDD CA)

Parameter		Unit	Value
Uplink downlink configuration (Note 1) for TDD CC			1
Special subframe configuration (Note 2) for TDD CC			4
Downlink power allocation	ρ_A	dB	-3
	ρ_B	dB	-3
	σ	dB	0
Cyclic prefix			Normal
Cell ID			0
Inter-TTI Distance			1
Maximum number of HARQ processes per component carrier	FDD PCell	Processes	8 for FDD and TDD CCs
	TDD PCell	Processes	11 for FDD CC; 7 for TDD CC
Maximum number of HARQ transmission			4
Redundancy version coding sequence			{0,0,1,2} for 64QAM, 256QAM
Number of OFDM symbols for PDCCH per component carrier		OFDM symbols	1
Cross carrier scheduling			Not configured
Propagation condition			Static propagation condition No external noise sources are applied
Transmission mode			TM3
Codebook subset restriction			10
Antenna configuration			2 x 2
\hat{E}_s at antenna port (dBm/15kHz)			-85
Symbols for unused PRBs			OP.1 FDD for FDD CC, OP.1 TDD for TDD CC
ACK/NACK feedback mode			PUCCH format 3
Downlink HARQ-ACK timing	FDD PCell		As specified in Clause 7.3.3 in TS36.213 [6]
	TDD PCell		As specified in Clause 7.3.4 in TS36.213 [6]
Note 1:		as specified in Table 4.2-2 in TS 36.211 [4].	
Note 2:		as specified in Table 4.2-1 in TS 36.211 [4].	

8.7.5.1 Minimum Requirement FDD PCell

For UE not supporting 256QAM, the requirements for TDD FDD CA with FDD PCell are specified in Table 8.7.5.1-1 with the additional parameters specified in Table 8.7.5-1, and the downlink physical channel setup according to Annex C.3.2. The test points are applied to UE category and bandwidth combination with maximum aggregated bandwidth as specified in Table 8.7.5.1-2. The TB success rate shall be sustained during at least 300 frames.

For UE supporting 256QAM, the requirements for TDD FDD CA with FDD PCell are specified in Table 8.7.5.1-3 with the additional parameters specified in Table 8.7.5-1, and the downlink physical channel setup according to Annex C.3.2. The test points are applied to UE category or UE DL category, and bandwidth combination with the maximum aggregated bandwidth as specified in Table 8.7.5.1-4. The TB success rate shall be sustained during at least 300 frames. For UE supporting 256QAM, the requirement in Table 8.7.5.1-1 is not applicable.

The applicability of the requirements are specified in Clause 8.1.2.3B. The test coverage for different number of component carriers is defined in 8.1.2.4.

Table 8.7.5.1-1: test parameters for sustained downlink data rate (TDD FDD CA 64QAM)

Test number	Bandwidth (MHz)			Number of bits of a DL-SCH transport block received within a TTI (for normal/special subframe for TDD, except for subframe #5)		Measurement channel		Reference value
	Total	FDD CC	TDD CC	FDD CC	TDD CC	FDD CC	TDD CC	TB success rate [%]
1	2x20	20	20	75376	75376/0	R.31-4 FDD	R.31-4 TDD	85
2	10+20	10	20	36696	75376/0	R.31-3A FDD	R.31-4 TDD	85
2A	15+20	15	20	55056	75376/0	R.31-5 FDD	R.31-4 TDD	85
3	10+10	10	10	36696	36696/0	R.31-3A FDD	R.31-6 TDD	85
4	3x20	20	2x20	75376	75376/0	R.31-4 FDD	R.31-4 TDD	85
5	15+20+20	15	2x20	55056	75376/0	R.31-5 FDD	R.31-4 TDD	85
6	10+20+20	10	2x20	36696	75376/0	R.31-3A FDD	R.31-4 TDD	85

Table 8.7.5.1-2: Test points for sustained data rate (FRC 64QAM)

CA config	Maximum supported Bandwidth/ Bandwidth combination (MHz)			Cat. 1	Cat. 2	Cat. 3	Cat. 4	Cat. 6, 7		Cat. 11, 12,
	Total	FDD CC	TDD CC					DL Cat. 6,7	DL Cat. 9, 10	
CA with 2CCs	2x20	20	20	-	-	3	3	1	1	-
	10+20	10	20	-	-	3	3	2	2	-
	15+20	15	20	-	-	3	3	2A	2A	-
CA with 3CCs	3x20	20	2x20	-	-	-	-	1	4	4
	15+20+20	15	2x20	-	-	-	-	2A	5	5
	10+20+20	10	2x20	-	-	-	-	2	6	6

Note 1: If DL category is signalled by the UE under test, then select the test point according to UE DL Category. Otherwise, select the test point according to the UE category signalled.

Note 2: Void.

Table 8.7.5.1-3: Minimum requirement (TDD FDD CA 256QAM)

Test number	Bandwidth (MHz)			Measurement channel		Reference value
	Total	FDD CC	TDD CC	FDD CC	TDD CC	TB success rate [%]
1	2x20	20	20	R.68 FDD	R.68 TDD	85
2	10+20	10	20	R.68-2 FDD	R.68 TDD	85
3	15+20	15	20	R.68-1 FDD	R.68 TDD	85
4	3x20	20	2x20	R.68 FDD	R.68 TDD	85
5	15+20+20	15	2x20	R.68-1 FDD	R.68 TDD	85
6	10+20+20	10	2x20	R.68-2 FDD	R.68TDD	85

Table 8.7.5.1-4: Test points for sustained data rate (FRC 256QAM)

CA config	Maximum supported Bandwidth/ Bandwidth combination (MHz)			Cat. 11, 12,	DL Cat. 13				
	Total	FDD CC	TDD CC	DL Cat. 11, 12					
CA with 2CCs	2x20	20	20	1	1				
	10+20	10	20	2	2				
	15+20	15	20	3	3				

CA with 3CCs	3x20	20	2x20	4	1				
	15+20+20	15	2x20	5	3				
	10+20+20	10	2x20	6	2				

Note 1: If DL category is signalled by the UE under test, then select the test point according to UE DL Category. Otherwise, select the test point according to the UE category signalled.

8.7.5.2 Minimum Requirement TDD PCell

For UE not supporting 256QAM, the requirements for TDD FDD CA with TDD PCell are specified in Table 8.7.5.2-1 with the additional parameters specified in Table 8.7.5-1, and the downlink physical channel setup according to Annex C.3.2. The test points are applied to UE category and bandwidth combination with maximum aggregated bandwidth as specified in Table 8.7.5.2-2. The TB success rate shall be sustained during at least 300 frames.

For UE supporting 256QAM, the requirements for TDD FDD CA with FDD PCell are specified in Table 8.7.5.2-3 with the additional parameters specified in Table 8.7.5-1, and the downlink physical channel setup according to Annex C.3.2. The test points are applied to UE category or UE DL category, and bandwidth combination with maximum aggregated bandwidth as specified in Table 8.7.5.2-4. The TB success rate shall be sustained during at least 300 frames. For UE supporting 256QAM, the requirements in Table 8.7.5.2-1 is not applicable.

The applicability of their requirements are specified in Clause 8.1.2.3B. The test coverage for different number of component carriers is defined in 8.1.2.4.

Table 8.7.5.2-1: test parameters for sustained downlink data rate (TDD FDD CA 64QAM)

Test number	Bandwidth (MHz)			Number of bits of a DL-SCH transport block received within a TTI (for normal/special subframe for TDD, except for subframe #5)		Measurement channel		Reference value
	Total	FDD CC	TDD CC	FDD CC	TDD CC	FDD CC	TDD CC	TB success rate [%]
1	2x20	20	20	75376	75376/0	R.31-4 FDD	R.31-4 TDD	85
2	10+20	10	20	36696	75376/0	R.31-3A FDD	R.31-4 TDD	85
2A	15+20	15	20	55056	75376/0	R.31-5 FDD	R.31-4 TDD	85
3	10+10	10	10	36696	36696/0	R.31-3A FDD	R.31-6 TDD	85
4	3x20	20	2x20	75376	75376/0	R.31-4 FDD	R.31-4 TDD	85
5	15+20+20	15	2x20	55056	75376/0	R.31-5 FDD	R.31-4 TDD	85
6	10+20+20	10	2x20	36696	75376/0	R.31-3A FDD	R.31-4 TDD	85

Table 8.7.5.2-2: Test points for sustained data rate (FRC 64QAM)

CA config	Maximum supported Bandwidth/ Bandwidth combination (MHz)			Cat. 1	Cat. 2	Cat. 3	Cat. 4	Cat. 6, 7	Cat. 9,10	Cat. 11, 12,
	Total	FDD CC	TDD CC					DL Cat. 6,7	DL Cat. 9, 10	DL Cat. 11, 12
CA with 2CCs	2x20	20	20	-	-	3	3	1	1	-
	10+20	10	20	-	-	3	3	2	2	-
	15+20	15	20	-	-	3	3	2A	2A	-
CA with 3CCs	3x20	20	2x20	-	-	-	-	1	4	4
	15+20+20	15	2x20	-	-	-	-	2A	5	5
	10+20+20	10	2x20	-	-	-	-	2	6	6

Note 1: If DL category is signalled by the UE under test, then select the test point according to UE DL Category. Otherwise, select the test point according to the UE category signalled.

Note 2: Void.

Table 8.7.5.2-3: Minimum requirement (TDD FDD CA 256QAM)

Test number	Bandwidth (MHz)			Measurement channel		Reference value
	Total	FDD CC	TDD CC	FDD CC	TDD CC	TB success rate [%]
1	2x20	20	20	R.68 FDD	R.68 TDD	85
2	10+20	10	20	R.68-2 FDD	R.68 TDD	85
3	15+20	15	20	R.68-1 FDD	R.68 TDD	85
4	3x20	20	2x20	R.68 FDD	R.68 TDD	85
5	15+20+20	15	2x20	R.68-1 FDD	R.68 TDD	85
6	10+20+20	10	2x20	R.68-2 FDD	R.68TDD	85

Table 8.7.5.2-4: Test points for sustained data rate (FRC 256QAM)

CA config	Maximum supported Bandwidth/ Bandwidth combination (MHz)			Cat. 11, 12	DL Cat. 13				
	Total	FDD CC	TDD CC	DL Cat. 11, 12					
CA with 2CCs	2x20	20	20	1	1				
	10+20	10	20	2	2				
	15+20	15	20	3	3				
CA with 3CCs	3x20	20	2x20	4	1				
	15+20+20	15	2x20	5	3				
	10+20+20	10	2x20	6	2				

Note 1: If DL category is signalled by the UE under test, then select the test point according to UE DL Category. Otherwise, select the test point according to the UE category signalled.

8.7.6 FDD (DC)

The parameters specified in Table 8.7.6-1 are valid for all FDD DC tests unless otherwise stated.

Table 8.7.6-1: Common Test Parameters (FDD)

Parameter	Unit	Value	
Cyclic prefix		Normal	
Cell ID		0	
Inter-TTI Distance		1	
Number of HARQ processes per component carrier	Processes	8	
Maximum number of HARQ transmission		4	
Redundancy version coding sequence		{0,0,1,2} for 64QAM and 256QAM	
Number of OFDM symbols for PDCCH per component carrier	OFDM symbols	1	
Cross carrier scheduling		Not configured	
Propagation condition		Static propagation condition No external noise sources are applied	
Transmission mode		TM3	
Codebook subset restriction		10	
Antenna configuration		2x2	
\hat{E}_s at antenna port (dBm/15kHz)		-85	
Symbols for unused PRBs		OP.1 FDD	
ACK/NACK feedback mode		Separate ACK/NACK feedbacks with PUCCH format 3 on the MCG and SCG	
Time offset between MCG CC and SCG CC	μs	0 for UE under test supporting synchronous dual connectivity; 500 for UE under test supporting both asynchronous and synchronous dual connectivity (Note 1)	
Downlink power allocation	ρ_A	dB	-3
	ρ_B	dB	-3
	σ	dB	0
Note 1: Asynchronous and synchrons dual connectivity are defined in TS36.300 [11].			
Note 2: If the UE supports both SCG bearer and Split bearer, the Split bearer is configured.			

For UE not supporting 256QAM, the requirements are specified in Table 8.7.6-2, with the addition of the parameters in Table 8.7.6-1 and the downlink physical channel setup according to Annex C.3.2. The test points are applied to UE category and bandwidth combination with maximum aggregated bandwidth as specified in Table 8.7.6-3. The TB success rate across CGs shall be sustained during at least 300 frames.

For UE supporting 256QAM, the requirements are specified in Table 8.7.6-4, with the addition of the parameters in Table 8.7.6-1 and the downlink physical channel setup according to Annex C.3.2. The test points are applied to UE category and bandwidth combination with maximum aggregated bandwidth as specified in Table 8.7.6-5. The TB success rate across CGs shall be sustained during at least 300 frames. For UE supporting 256QAM, the requirements in Table 8.7.6-2 are not applicable.

The applicability of their requirements are specified in Clause 8.1.2.3A.

Table 8.7.6-2: Minimum requirement (DC 64QAM)

Test number	Bandwidth combination (MHz)	Number of bits of a DL-SCH transport block received within a TTI	Measurement channel	Reference value TB success rate(%)		
				DRB type of Split bearer (Note 2)	DRB type of SCG bearer (Note 3)	
					MCG	SCG
1	2x10	25456	R.31-2 FDD	95	95	95
2	2x10	36696 (Note 4)	R.31-3A FDD	85	85	85
3	10+20	36696 (Note 4) for 10MHz CC 75376 (Note 5) for 20MHz CC	R.31-3A FDD for 10MHz CC R.31-4 FDD for 20MHz CC	85	85	85
4	2x15	55056 (Note 6)	R.31-4B FDD	85	85	85
5	15+20	55056 for 15MHz CC 75376 (Note 5) for 20MHz CC	R.31-5 FDD for 15MHz CC R.31-4 FDD for 20MHz CC	85	85	85
6	2x20	75376 (Note 5)	R.31-4 FDD	85	85	85
Note 1:	For 2 layer transmissions, 2 transport blocks are received within a TTI.					
Note 2:	For the configuration of DRB type of Split bearer, the TB success rate across CGs is defined as TB success rate = $100\% \cdot N_{DL_correct_rx} / (N_{DL_newtx} + N_{DL_retx})$, where N_{DL_newtx} is the number of newly transmitted DL transport blocks, N_{DL_retx} is the number of retransmitted DL transport blocks, and $N_{DL_correct_rx}$ is the number of correctly received DL transport blocks. All the above numbers of transmitted, retransmitted or correctly received DL transport blocks are calculated as the sum of the numbers of DL transport blocks across all the CGs used for DC transmission or reception.					
Note 3:	For the configuration of DRB type of SCG bearer, the TB success rate across CGs is defined as TB success rate = $100\% \cdot N_{DL_correct_rx} / (N_{DL_newtx} + N_{DL_retx})$, where N_{DL_newtx} is the number of newly transmitted DL transport blocks, N_{DL_retx} is the number of retransmitted DL transport blocks, and $N_{DL_correct_rx}$ is the number of correctly received DL transport blocks. All the above numbers of transmitted, retransmitted or correctly received DL transport blocks are calculated as the sum of the numbers of DL transport blocks per CG used for DC transmission or reception, separately.					
Note 4:	35160 bits for sub-frame 5.					
Note 5:	71112 bits for sub-frame 5.					
Note 6:	52752 bits for sub-frame 5.					

Table 8.7.6-3: Test points for sustained data rate (FRC DC 64QAM)

DC config	Maximum supported Bandwidth combination (MHz)	Cat. 3	Cat. 4	Cat. 6, 7	Cat. 9, 10	Cat. 11, 12	
DC with 2CCs	2x10	1	2	2	2	-	
	10+20	1	2	3	3	-	
	2x15	1	2	4	4	-	
	15+20	1	2	5	5	-	
	2x20	1	2	6	6	-	

Table 8.7.6-4: Minimum requirement (DC 256QAM)

Test number	Bandwidth combination (MHz)	Measurement channel	Reference value TB success rate (%)		
			DRB type of Split bearer (Note 2)	DRB type of SCG bearer (Note 3)	
				MCG	SCG
1	2x10	R.68-2 FDD	85	85	85
2	10+20	R.68-2 FDD for 10MHz CC R.68 FDD for 20MHz CC	85	85	85
3	2x15	R.68-1 FDD	85	85	85
4	15+20	R.68-1 FDD for 15MHz CC R.68 FDD for 20MHz CC	85	85	85
5	2x20	R.68 FDD	85	85	85
Note 1:	For 2 layer transmissions, 2 transport blocks are received within a TTI.				
Note 2:	For the configuration of DRB type of Split bearer, the TB success rate across CGs is defined as TB success rate = $100\% \cdot N_{DL_correct_rx} / (N_{DL_newtx} + N_{DL_retx})$, where N_{DL_newtx} is the number of newly transmitted DL transport blocks, N_{DL_retx} is the number of retransmitted DL transport blocks, and $N_{DL_correct_rx}$ is the number of correctly received DL transport blocks. All the above numbers of transmitted, retransmitted or correctly received DL transport blocks are calculated as the sum of the numbers of DL transport blocks across all the CGs used for DC transmission or reception.				
Note 3:	For the configuration of DRB type of SCG bearer, the TB success rate across CGs is defined as TB success rate = $100\% \cdot N_{DL_correct_rx} / (N_{DL_newtx} + N_{DL_retx})$, where N_{DL_newtx} is the number of newly transmitted DL transport blocks, N_{DL_retx} is the number of retransmitted DL transport blocks, and $N_{DL_correct_rx}$ is the number of correctly received DL transport blocks. All the above numbers of transmitted, retransmitted or correctly received DL transport blocks are calculated as the sum of the numbers of DL transport blocks per CG used for DC transmission or reception, separately.				

Table 8.7.6-5: Test points for sustained data rate (FRC DC 256QAM)

DC config	Maximum supported Bandwidth combination (MHz)	Cat. 11, 12	DL Cat. 13				
		DL Cat 11, 12					
DC with 2CCs	2x10	1	1				
	10+20	2	2				
	2x15	3	3				
	15+20	4	4				
	2x20	5	5				

8.7.7 TDD (DC)

The parameters specified in Table 8.7.7-1 are valid for all TDD DC tests unless otherwise stated.

Table 8.7.7-1: Common Test Parameters (TDD)

Parameter	Unit	Value	
Uplink downlink configuration		2 (Note 2)	
Special subframe configuration		4	
Cyclic prefix		Normal	
Cell ID		0	
Inter-TTI Distance		1	
Number of HARQ processes per component carrier	Processes	7	
Maximum number of HARQ transmission		4	
Redundancy version coding sequence		{0,0,1,2} for 64QAM and 256QAM	
Number of OFDM symbols for PDCCH per component carrier	OFDM symbols	1	
Cross carrier scheduling		Not configured	
Propagation condition		Static propagation condition No external noise sources are applied	
Transmission mode		TM3	
Codebook subset restriction		10	
Antenna configuration		2x2	
\hat{E}_s at antenna port (dBm/15kHz)		-85	
Symbols for unused PRBs		OP.1 TDD	
ACK/NACK feedback mode		Separate ACK/NACK feedbacks with PUCCH format 3 on the MCG and SCG	
Time offset between MCG CC and SCG CC	μs	0 for UE under test supporting synchronous dual connectivity; 500 for UE under test supporting both asynchronous and synchronous dual connectivity (Note 1)	
Downlink power allocation	ρ_A	dB	-3
	ρ_B	dB	-3
	σ	dB	0
Note 1: Asynchronous and synchronous dual connectivity are defined in TS36.300 [11].			
Note 2: If the UE supports both SCG bearer and Split bearer, the Split bearer is configured.			

For UE not supporting 256QAM, the requirements are specified in Table 8.7.7-2, with the addition of the parameters in Table 8.7.7-1 and the downlink physical channel setup according to Annex C.3.2. The test points are applied to UE category and bandwidth combination with maximum aggregated bandwidth as specified in Table 8.7.7-3. The TB success rate shall be sustained during at least 300 frames.

For UE supporting 256QAM, the requirements are specified in Table 8.7.7-4, with the addition of the parameters in Table 8.7.7-1 and the downlink physical channel setup according to Annex C.3.2. The test points are applied to UE category and bandwidth combination with maximum aggregated bandwidth as specified in Table 8.7.7-5. The TB success rate shall be sustained during at least 300 frames. For UE supporting 256QAM, the requirements in Table 8.7.7-2 are not applicable.

The applicability of their requirements are specified in Clause 8.1.2.3A.

Table 8.7.7-2: Minimum requirement (DC 64QAM)

Test number	Bandwidth combination (MHz)	Number of bits of a DL-SCH transport block received within a TTI	Measurement channel	Reference value TB success rate across CGs(%)		
				DRB type of Split bearer (Note 2)	DRB type of SCG bearer (Note 3)	
					MCG	SCG
1	2x20	75376/0 (Note 4)	R.31-4A TDD	85	85	85
Note 1:	For 2 layer transmissions, 2 transport blocks are received within a TTI.					
Note 2:	For the configuration of DRB type of Split bearer, the TB success rate across CGs is defined as TB success rate = $100\% \cdot N_{DL_correct_rx} / (N_{DL_newtx} + N_{DL_retx})$, where N_{DL_newtx} is the number of newly transmitted DL transport blocks, N_{DL_retx} is the number of retransmitted DL transport blocks, and $N_{DL_correct_rx}$ is the number of correctly received DL transport blocks. All the above numbers of transmitted, retransmitted or correctly received DL transport blocks are calculated as the sum of the numbers of DL transport blocks across all the CGs used for DC transmission or reception.					
Note 3:	For the configuration of DRB type of SCG bearer, the TB success rate across CGs is defined as TB success rate = $100\% \cdot N_{DL_correct_rx} / (N_{DL_newtx} + N_{DL_retx})$, where N_{DL_newtx} is the number of newly transmitted DL transport blocks, N_{DL_retx} is the number of retransmitted DL transport blocks, and $N_{DL_correct_rx}$ is the number of correctly received DL transport blocks. All the above numbers of transmitted, retransmitted or correctly received DL transport blocks are calculated as the sum of the numbers of DL transport blocks per CG used for DC transmission or reception, separately.					
Note 4:	71112 bits for sub-frame 5.					

Table 8.7.7-3: Test points for sustained data rate (FRC DC 64QAM)

DC config	Maximum supported Bandwidth combination (MHz)	Cat. 3	Cat. 4	Cat. 6, 7	Cat. 9, 10	Cat. 11, 12
DC with 2CCs	2x20	-	-	1	1	-

Table 8.7.7-4: Minimum requirement (DC 256QAM)

Test number	Bandwidth combination (MHz)	Measurement channel	Reference value TB success rate (%)		
			DRB type of Split bearer (Note 2)	DRB type of SCG bearer (Note 3)	
				MCG	SCG
1	2x20	R.68-3 TDD	85	85	85
Note 1:	For 2 layer transmissions, 2 transport blocks are received within a TTI.				
Note 2:	For the configuration of DRB type of Split bearer, the TB success rate across CGs is defined as TB success rate = $100\% \cdot N_{DL_correct_rx} / (N_{DL_newtx} + N_{DL_retx})$, where N_{DL_newtx} is the number of newly transmitted DL transport blocks, N_{DL_retx} is the number of retransmitted DL transport blocks, and $N_{DL_correct_rx}$ is the number of correctly received DL transport blocks. All the above numbers of transmitted, retransmitted or correctly received DL transport blocks are calculated as the sum of the numbers of DL transport blocks across all the CGs used for DC transmission or reception.				
Note 3:	For the configuration of DRB type of SCG bearer, the TB success rate across CGs is defined as TB success rate = $100\% \cdot N_{DL_correct_rx} / (N_{DL_newtx} + N_{DL_retx})$, where N_{DL_newtx} is the number of newly transmitted DL transport blocks, N_{DL_retx} is the number of retransmitted DL transport blocks, and $N_{DL_correct_rx}$ is the number of correctly received DL transport blocks. All the above numbers of transmitted, retransmitted or correctly received DL transport blocks are calculated as the sum of the numbers of DL transport blocks per CG used for DC transmission or reception, separately.				

Table 8.7.7-5: Test points for sustained data rate (FRC DC 256QAM)

DC config	Maximum supported Bandwidth combination (MHz)	Cat. 11, 12	DL Cat. 13				
		DL Cat. 11, 12					
DC with 2CCs	2x20	1	1				

8.8 Demodulation of EPDCCH

The receiver characteristics of the EPDCCH are determined by the probability of miss-detection of the Downlink Scheduling Grant (Pm-dsg). For the distributed transmission tests in 8.8.1, EPDCCH and PCFICH are tested jointly, i.e. a miss detection of PCFICH implies a miss detection of EPDCCH. For other tests, EPDCCH and PCFICH are not tested jointly.

8.8.1 Distributed Transmission

8.8.1.1 FDD

The parameters specified in Table 8.8.1.1-1 are valid for all FDD distributed EPDCCH tests unless otherwise stated.

Table 8.8.1.1-1: Test Parameters for Distributed EPDCCH

Parameter		Unit	Value
Number of PDCCH symbols		symbols	2 (Note 1)
PHICH duration			Normal
Unused RE-s and PRB-s			OCNG
Cell ID			0
Downlink power allocation	ρ_A	dB	-3
	ρ_B	dB	-3
	σ	dB	0
	δ	dB	3
N_{oc} at antenna port		dBm/15 kHz	-98
Cyclic prefix			Normal
Subframe Configuration			Non-MBSFN
Precoder Update Granularity		PRB	1
		ms	1
Beamforming Pre-Coder			Annex B. 4.4
Cell Specific Reference Signal			Port 0 and 1
Number of EPDCCH Sets Configured			2 (Note 2)
Number of PRB per EPDCCH Set			4 (1 st Set)
			8 (2 nd Set)
EPDCCH Subframe Monitoring			NA
PDSCH TM			TM3
DCI Format			2A
Note 1:	The starting symbol for EPDCCH is derived from the PCFICH. RRC signalling <i>epdcch-StartSymbol-r11</i> is not configured.		
Note 2:	The two sets are distributed EPDCCH sets and non-overlapping with PRB = {3, 17, 31, 45} for the first set and PRB = {0, 7, 14, 21, 28, 35, 42, 49} for the second set. EPDCCH is scheduled in the first set for Test 1 and second set for Test 2, respectively. Both sets are always configured.		

For the parameters specified in Table 8.8.1.1-1 the average probability of a missed downlink scheduling grant (Pm-dsg) shall be below the specified value in Table 8.8.1.1-2. The downlink physical setup is in accordance with Annex C.3.2.

Table 8.8.1.1-2: Minimum performance Distributed EPDCCH

Test number	Bandwidth	Aggregation level	Reference Channel	OCNG Pattern	Propagation Condition	Antenna configuration and correlation Matrix	Reference value	
							Pm-dsg (%)	SNR (dB)
1	10 MHz	4 ECCE	R.55 FDD	OP.7 FDD	EVA5	2 x 2 Low	1	2.60
2	10 MHz	16 ECCE	R.56 FDD	OP.7 FDD	EVA70	2 x 2 Low	1	-3.20

8.8.1.1.1 Void

Table 8.8.1.1.1-1: Void

8.8.1.2 TDD

The parameters specified in Table 8.8.1.2-1 are valid for all TDD distributed EPDCCH tests unless otherwise stated.

Table 8.8.1.2-1: Test Parameters for Distributed EPDCCH

Parameter		Unit	Value
Number of PDCCH symbols		symbols	2 (Note 1)
PHICH duration			Normal
Unused RE-s and PRB-s			OCNG
Cell ID			0
Downlink power allocation	ρ_A	dB	-3
	ρ_B	dB	-3
	σ	dB	0
	δ	dB	3
N_{oc} at antenna port		dBm/15 kHz	-98
Cyclic prefix			Normal
Subframe Configuration			Non-MBSFN
Precoder Update Granularity	PRB		1
	ms		1
Beamforming Pre-Coder			Annex B. 4.4
Cell Specific Reference Signal			Port 0 and 1
Number of EPDCCH Sets Configured			2 (Note 2)
Number of PRB per EPDCCH Set			4 (1 st Set) 8 (2 nd Set)
EPDCCH Subframe Monitoring			NA
PDSCH TM			TM3
DCI Format			2A
TDD UL/DL Configuration			0
TDD Special Subframe			1 (Note 3)
Note 1:	The starting symbol for EPDCCH is derived from the PCFICH. RRC signalling <i>epdcch-StartSymbol-r11</i> is not configured.		
Note 2:	The two sets are distributed EPDCCH sets and non-overlapping with PRB = {3, 17, 31, 45} for the first set and PRB = {0, 7, 14, 21, 28, 35, 42, 49} for the second set. EPDCCH is scheduled in the first set for Test 1 and second set for Test 2, respectively. Both sets are always configured.		
Note 3:	Demodulation performance is averaged over normal and special subframe.		

For the parameters specified in Table 8.8.1.2-1 the average probability of a missed downlink scheduling grant (Pm-dsg) shall be below the specified value in Table 8.8.1.2-2. The downlink physical setup is in accordance with Annex C.3.2.

Table 8.8.1.2-2: Minimum performance Distributed EPDCCH

Test number	Bandwidth	Aggregation level	Reference Channel	OCNG Pattern	Propagation Condition	Antenna configuration and correlation Matrix	Reference value	
							Pm-dsg (%)	SNR (dB)
1	10 MHz	4 ECCE	R.55 TDD	OP.7 TDD	EVA5	2 x 2 Low	1	2.80
2	10 MHz	16 ECCE	R.56 TDD	OP.7 TDD	EVA70	2 x 2 Low	1	-3.10

8.8.1.2.1 Void

Table 8.8.1.2.1-1: Void

8.8.2 Localized Transmission with TM9

8.8.2.1 FDD

The parameters specified in Table 8.8.2.1-1 are valid for all FDD TM9 localized ePDCCH tests unless otherwise stated.

Table 8.8.2.1-1: Test Parameters for Localized EPDCCH with TM9

Parameter	Unit	Value	
Number of PDCCH symbols	symbols	1 (Note 1)	
EPDCCH starting symbol	symbols	2 (Note 1)	
PHICH duration		Normal	
Unused RE-s and PRB-s		OCNG	
Cell ID		0	
Downlink power allocation	ρ_A	dB	0
	ρ_B	dB	0
	σ	dB	-3
	δ	dB	0
N_{oc} at antenna port	dBm/15 kHz	-98	
Cyclic prefix		Normal	
Subframe Configuration		Non-MBSFN	
Precoder Update Granularity	PRB	1	
	ms	1	
Beamforming Pre-Coder		Annex B.4.5	
Cell Specific Reference Signal		Port 0 and 1	
CSI-RS Reference Signal		Port 15 and 16	
CSI-RS reference signal resource configuration		0	
CSI reference signal subframe configuration l_{CSI-RS}		2	
ZP-CSI-RS configuration bitmap		0000010000000000	
ZP-CSI-RS subframe configuration $l_{ZP-CSI-RS}$		2	
Number of EPDCCH Sets		2 (Note 2)	
EPDCCH Subframe Monitoring pattern <i>subframePatternConfig-r11</i>		1111111110 1111111101 1111111011 1111110111 (Note 3)	
PDSCH TM		TM9	
Note 1:	The starting symbol for EPDCCH is signalled with <i>epdcch-StartSymbol-r11</i> . However, CFI is set to 1.		
Note 2:	The first set is distributed transmission with PRB = {0, 49} and the second set is localized transmission with PRB = {0, 7, 14, 21, 28, 35, 42, 49}. ePDCCH is scheduled in the second set for all tests.		
Note 3:	EPDCCH is scheduled in every SF. UE is required to monitor ePDCCH for UE-specific search space only in SFs configured by <i>subframePatternConfig-r11</i> . Legacy PDCCH is not scheduled.		

For the parameters specified in Table 8.8.2.1-1 the average probability of a missed downlink scheduling grant (Pm-dsg) shall be below the specified value in Table 8.8.2.1-2. EPDCCH subframe monitoring is configured and the subframe monitoring requirement in EPDCCH restricted subframes is statDTX of 99.9%.

The downlink physical setup is in accordance with Annex C.3.2.

Table 8.8.2.1-2: Minimum performance Localized EPDCCH with TM9

Test number	Bandwidth	Aggregation level	Reference Channel	OCNG Pattern	Propagation Condition	Antenna configuration and correlation Matrix	Reference value	
							Pm-dsg (%)	SNR (dB)
1	10 MHz	2 ECCE	R.57 FDD	OP.7 FDD	EVA5	2 x 2 Low	1	12.2
2	10 MHz	8 ECCE	R.58 FDD	OP.7 FDD	EVA5	2 x 2 Low	1	2.5

8.8.2.1.1 Void

Table 8.8.2.1.1-1: Void

8.8.2.1.2 Void

Table 8.8.2.1.2-1: Void

Table 8.8.2.1.2-2: Void

Table 8.8.2.1.2-3: Void

8.8.2.2 TDD

The parameters specified in Table 8.8.2.2-1 are valid for all TDD TM9 localized ePDCCH tests unless otherwise stated.

Table 8.8.2.2-1: Test Parameters for Localized EPDCCH with TM9

Parameter		Unit	Value
Number of PDCCH symbols		symbols	1 (Note 1)
EPDCCH starting symbol		symbols	2 (Note 1)
PHICH duration			Normal
Unused RE-s and PRB-s			OCNG
Cell ID			0
Downlink power allocation	ρ_A	dB	0
	ρ_B	dB	0
	σ	dB	-3
	δ	dB	0
N_{oc} at antenna port		dBm/15 kHz	-98
Cyclic prefix			Normal
Subframe Configuration			Non-MBSFN
Precoder Update Granularity	PRB		1
	ms		1
Beamforming Pre-Coder			Annex B.4.5
Cell Specific Reference Signal			Port 0 and 1
CSI-RS Reference Signal			Port 15 and 16
CSI-RS reference signal resource configuration			0
CSI reference signal subframe configuration l_{CSI-RS}			0
ZP-CSI-RS configuration bitmap			0000010000000000
ZP-CSI-RS subframe configuration $l_{ZP-CSI-RS}$			0
Number of EPDCCH Sets			2 (Note 2)
EPDCCH Subframe Monitoring pattern <i>subframePatternConfig-r11</i>			1100011000 1100010000 1100011000 1100001000 1100011000 1000011000 1100011000 (Note 3)
PDSCH TM			TM9
TDD UL/DL Configuration			0
TDD Special Subframe			1 (Note 4)
Note 1: The starting symbol for EPDCCH is signalled with <i>epdcch-StartSymbol-r11</i> . However, CFI is set to 1.			
Note 2: The first set is distributed transmission with PRB = {0, 49} and the second set is localized transmission with PRB = {0, 7, 14, 21, 28, 35, 42, 49}. ePDCCH is scheduled in the second set for all tests.			
Note 3: EPDCCH is scheduled in every SF. UE is required to monitor ePDCCH for UE-specific search space only in SFs configured by <i>subframePatternConfig-r11</i> . Legacy PDCCH is not scheduled.			
Note 4: Demodulation performance is averaged over normal and special subframe.			

For the parameters specified in Table 8.8.2.2-1 the average probability of a missed downlink scheduling grant (Pm-dsg) shall be below the specified value in Table 8.2.2.2-2. EPDCCH subframe monitoring is configured and the subframe monitoring requirement in EPDCCH restricted subframes is statDTX of 99.9%.

The downlink physical setup is in accordance with Annex C.3.2.

Table 8.8.2.2-2: Minimum performance Localized EPDCCH with TM9

Test number	Bandwidth	Aggregation level	Reference Channel	OCNG Pattern	Propagation Condition	Antenna configuration and correlation Matrix	Reference value	
							Pm-dsg (%)	SNR (dB)
1	10 MHz	2 ECCE	R.57 TDD	OP.7 TDD	EVA5	2 x 2 Low	1	12.8
2	10 MHz	8 ECCE	R.58 TDD	OP.7 TDD	EVA5	2 x 2 Low	1	2.0

8.8.2.2.1 Void

Table 8.8.2.2.1-1: Void

8.8.2.2.2 Void

Table 8.8.2.2.2-1: Void

Table 8.8.2.2.2-2: Void

Table 8.8.2.2.2-3: Void

8.8.3 Localized transmission with TM10 Type B quasi co-location type

8.8.3.1 FDD

For the parameters specified in Table 8.8.3.1-1 the average probability of a missed downlink scheduling grant (P_{m-dsg}) shall be below the specified values in Table 8.8.3.1-2. In Table 8.8.3.1-1, transmission point 1 (TP 1) is the serving cell. The downlink physical setup is in accordance with Annex C.3.2.

Table 8.8.3.1-1: Test Parameters for Localized Transmission TM10 Type B quasi co-location type

Parameter		Unit	Test 1		Test 2	
			TP 1	TP 2	TP 1	TP 2
PHICH duration			Normal			
Downlink power allocation	ρ_A	dB	0			
	ρ_B	dB	0			
	σ	dB	-3			
	δ	dB	0			
\hat{E}_s/N_{oc}		dB	0dB power imbalance is considered between TP 1 and TP 2,	Reference value in Table 8.8.3.1-2	Reference value in Table 8.8.3.1-2	Reference value in Table 8.8.3.1-2
N_{oc} at antenna port		dBm/15kHz	-98			
Bandwidth		MHz	10	10	10	10
Number of configured EPDCCH Sets			2 (Note 1)		2 (Note1)	
EPDCCH-PRB-Set ID (setConfigId)			0	1	0	1
Transmission type of EPDCCH-PRB-set			Localized	Localized	Localized	Localized
Number of PRB pair per EPDCCH-PRB-set		PRB	8	8	8	8
EPDCCH beamforming model			Annex B.4.5	Annex B.4.5	Annex B.4.5	Annex B.4.5
PDSCH transmission mode			TM10	TM10	TM10	TM10
PDSCH transmission scheduling			Blanked in all the subframes	Transmit in all the subframes	Probability of occurrence of PDSCH transmission is 30% (Note 3)	Probability of occurrence of PDSCH transmission is 70% (Note 3)
Non-zero power CSI reference signal (NZPId=1)	CSI reference signal configuration		N/A	0	N/A	0
	CSI reference signal subframe configuration I_{CSI-RS}		N/A	2	N/A	2
Non-zero power CSI reference signal (NZPId=2)	CSI reference signal configuration		N/A	N/A	10	N/A
	CSI reference signal subframe configuration I_{CSI-RS}		N/A	N/A	2	N/A
Zero power CSI reference signal (ZPId=1)	CSI-RS Configuration list (ZeroPowerCSI-RS bitmap)	Bitmap	N/A	000001000000000	N/A	100001000000000
	CSI-RS subframe configuration I_{CSI-RS}		N/A	2	N/A	2
Zero power CSI reference signal (ZPId=2)	CSI-RS Configuration list (ZeroPowerCSI-RS bitmap)	Bitmap	N/A	N/A	100001000000000	N/A
	CSI-RS subframe configuration I_{CSI-RS}		N/A	N/A	2	N/A
PQI set 0 (Note 4)	Non-Zero power CSI RS Identity (NZPId)		N/A	1	N/A	1

	Zero power CSI RS Identity (ZPId)		N/A	1	N/A	1
PQI set 1 (Note 4)	Non-Zero power CSI RS Identity (NZPId)		N/A	N/A	2	N/A
	Zero power CSI RS Identity (ZPId)		N/A	N/A	2	N/A
Number of PDCCH symbols	Symbols	1 (Note 2)				
EPDCCH starting position		pdsch-Start-r11=2 (Note 2)	pdsch-Start-r11=2 (Note 2)	pdsch-Start-r11=2 (Note 2)	pdsch-Start-r11=2 (Note 2)	
Subframe configuration		Non-MBSFN	Non-MBSFN	Non-MBSFN	Non-MBSFN	
Time offset between TPs	μ s	N/A	2	N/A	2	
Frequency shift between TPs	Hz	N/A	200	N/A	200	
Cell ID		0	126	0	126	
Note 1:	Resource blocks $n_{PRB} = 0, 7, 14, 21, 28, 35, 42, 49$ are allocated for both the first set and the second set.					
Note 2:	The starting OFDM symbol for EPDCCH is determined from the higher layer signalling pdsch-Start-r11. And CFI is set to 1.					
Note 3:	The TP from which PDSCH is transmitted shall be randomly determined independently for each subframe. Probabilities of occurrence of PDSCH transmission from TP 1 and TP 2 are specified.					
Note 4:	For PQI set 0, PDSCH and EPDCCH are transmitted from TP 2. For PQI set 1, PDSCH and EPDCCH are transmitted from TP1. EPDCCH and PDSCH are transmitted from same TP.					

Table 8.8.3.1-2: Minimum Performance

Test number	Aggregation level	Reference Channel	OCNG Pattern	Propagation Condition	Antenna configuration and correlation Matrix	Reference value	
						Pm-dsg (%)	SNR (dB)
1	2 ECCE	R.59 FDD	OP.7 FDD	EVA5	2 x 2 Low	1	13.4
2	2 ECCE	R.59 FDD	OP.7 FDD	EVA5	2 x 2 Low	1	13.4

8.8.3.2 TDD

For the parameters specified in Table 8.8.3.2-1 the average probability of a missed downlink scheduling grant (Pm-dsg) shall be below the specified values in Table 8.8.3.2-2. In Table 8.8.3.2-1, transmission point 1 (TP1) is the serving cell. The downlink physical setup is in accordance with Annex C.3.2.

Table 8.8.3.2-1: Test Parameters for Localized Transmission TM10 Type B quasi co-location type

Parameter		Unit	Test 1		Test 2	
			TP 1	TP 2	TP 1	TP 2
PHICH duration			Normal			
Downlink power allocation	ρ_A	dB	0			
	ρ_B	dB	0			
	σ	dB	-3			
	δ	dB	0			
\hat{E}_s / N_{oc}		dB	0dB power imbalance is considered between TP 1 and TP 2,	Reference value in Table 8.8.3.2-2	Reference value in Table 8.8.3.2-2	Reference value in Table 8.8.3.2-2
N_{oc} at antenna port		dBm/15kHz	-98			
Bandwidth		MHz	10	10	10	10
Number of EPDCCH Sets			2 (Note 1)		2 (Note1)	
EPDCCH-PRB-Set ID (setConfigId)			0	1	0	1
Transmission type of EPDCCH-PRB-set			Localized	Localized	Localized	Localized
Number of PRB pair per EPDCCH-PRB-set		PRB	8	8	8	8
EPDCCH beamforming model			Annex B.4.5	Annex B.4.5	Annex B.4.5	Annex B.4.5
PDSCH transmission mode			TM10	TM10	TM10	TM10
PDSCH transmission scheduling			Blanked in all the subframes	Transmit in all the subframes	Probability of occurrence of PDSCH transmission is 30% (Note 3)	Probability of occurrence of PDSCH transmission is 70% (Note 3)
CSI reference signal configurations			Antenna ports 15,16	Antenna ports 15,16	Antenna ports 15,16	Antenna ports 15,16
Non-zero power CSI reference signal (NZPId=1)	CSI reference signal configuration		N/A	0	N/A	0
	CSI reference signal subframe configuration l_{CSI-RS}		N/A	0	N/A	0
Non-zero power CSI reference signal (NZPId=2)	CSI reference signal configuration		N/A	N/A	10	N/A
	CSI reference signal subframe configuration l_{CSI-RS}		N/A	N/A	0	N/A
Zero power CSI reference signal (ZPId=1)	CSI-RS Configuration list (ZeroPowerCSI-RS bitmap)	Bitmap	N/A	000001000000000	N/A	100001000000000
	CSI-RS subframe configuration l_{CSI-RS}		N/A	0	N/A	0
Zero power CSI reference signal (ZPId=2)	CSI-RS Configuration list (ZeroPowerCSI-RS bitmap)	Bitmap	N/A	N/A	100001000000000	N/A
	CSI-RS subframe configuration l_{CSI-RS}		N/A	N/A	0	N/A

PQI set 0 (Note 4)	Non-Zero power CSI RS Identity (NZPId)		N/A	1	N/A	1
	Zero power CSI RS Identity (ZPId)		N/A	1	N/A	1
PQI set 1 (Note 4)	Non-Zero power CSI RS Identity (NZPId)		N/A	N/A	2	N/A
	Zero power CSI RS Identity (ZPId)		N/A	N/A	2	N/A
Number of PDCCH symbols		Symbols	1 (Note 2)			
EPDCCH starting position			pdsch-Start-r11=2 (Note 2)	pdsch-Start-r11=2 (Note 2)	pdsch-Start-r11=2 (Note 2)	pdsch-Start-r11=2 (Note 2)
Subframe configuration			Non-MBSFN	Non-MBSFN	Non-MBSFN	Non-MBSFN
Time offset between TPs		μs	N/A	2	N/A	2
Frequency shift between TPs		Hz	N/A	200	N/A	200
Cell ID			0	126	0	126
TDD UL/DL configuration			0			
TDD special subframe			1			
<p>Note 1: Resource blocks $n_{PRB} = 0, 7, 14, 21, 28, 35, 42, 49$ are allocated for both the first set and the second set.</p> <p>Note 2: The starting OFDM symbol for EPDCCH is determined from the higher layer signalling pdsch-Start-r11. And CFI is set to 1.</p> <p>Note 3: The TP from which PDSCH is transmitted shall be randomly determined independently for each subframe. Probabilities of occurrence of PDSCH transmission from TP 1 and TP 2 are specified.</p> <p>Note 4: For PQI set 0, PDSCH and EPDCCH are transmitted from TP 2. For PQI set 1, PDSCH and EPDCCH are transmitted from TP1. EPDCCH and PDSCH are transmitted from same TP.</p>						

Table 8.8.3.2-2: Minimum Performance

Test number	Aggregation level	Reference Channel	OCNG Pattern	Propagation Condition	Antenna configuration and correlation Matrix	Reference value	
						Pm-dsg (%)	SNR (dB)
1	2 ECCE	R.59 TDD	OP.7 TDD	EVA5	2 x 2 Low	1	13.6
2	2 ECCE	R.59 TDD	OP.7 TDD	EVA5	2 x 2 Low	1	13.6

8.9 Demodulation (single receiver antenna)

The SNR definition is given in Clause 8.1.1 where the number of receiver antennas N_{RX} assumed for the minimum performance requirement in this clause is 1.

8.9.1 PDSCH

8.9.1.1 FDD and half-duplex FDD (Fixed Reference Channel)

The parameters specified in Table 8.9.1.1-1 are valid for FDD and half-duplex FDD tests unless otherwise stated.

Table 8.9.1.1-1: Common Test Parameters (FDD and half-duplex FDD)

Parameter	Unit	Value
Inter-TTI Distance		1
Number of HARQ processes per component carrier	Processes	8
Maximum number of HARQ transmission		4
Redundancy version coding sequence		{0,1,2,3} for QPSK and 16QAM {0,0,1,2} for 64QAM
Number of OFDM symbols for PDCCH per component carrier	OFDM symbols	4 for 1.4 MHz bandwidth, 3 for 3 MHz and 5 MHz bandwidths, 2 for 10 MHz, 15 MHz and 20 MHz bandwidths
Cyclic Prefix		Normal
Precoder update granularity		Frequency domain: 1 PRG Time domain: 1 ms for Transmission mode 9

8.9.1.1.1 Transmit diversity performance (Cell-Specific Reference Symbols)

8.9.1.1.1.1 Minimum Requirement 2 Tx Antenna Port

The requirements are specified in Table 8.9.1.1.1-2, with the addition of the parameters in Table 8.9.1.1.1-1 and the downlink physical channel setup according to Annex C.3.2. The purpose is to verify the performance of transmit diversity (SFBC) with 2 transmitter antennas.

Table 8.9.1.1.1-1: Test Parameters for Transmit diversity Performance (FRC)

Parameter	Unit	Test 1	
Downlink power allocation	ρ_A	dB	-3
	ρ_B	dB	-3 (Note 1)
	σ	dB	0
N_{oc} at antenna port	dBm/15kHz	-98	
PDSCH transmission mode		2	
Note 1: $P_B = 1$.			

Table 8.9.1.1.1-2: Minimum performance Transmit Diversity (FRC)

Test number	Bandwidth and MCS	Reference Channel	OCNG Pattern	Propagation Condition	Correlation Matrix and Antenna Configuration	Reference value		UE DL category
						Fraction of Maximum Throughput (%)	SNR (dB)	
1	10 MHz 16QAM 1/2	R.62 FDD	OP.1 FDD	EPA5	2x1 Low	70	9.0	0

8.9.1.1.2 Closed-loop spatial multiplexing performance (Cell-Specific Reference Symbols)

8.9.1.1.2.1 Minimum Requirement Single-Layer Spatial Multiplexing 2 Tx Antenna Port

The requirements are specified in Table 8.9.1.1.2-2, with the addition of the parameters in Table 8.9.1.1.2.1-1 and the downlink physical channel setup according to Annex C.3.2. The purpose of these tests is to verify the closed loop rank-one performance with frequency selective precoding.

Table 8.9.1.1.2.1-1: Test Parameters for Single-Layer Spatial Multiplexing (FRC)

Parameter		Unit	Test 1
Downlink power allocation	ρ_A	dB	-3
	ρ_B	dB	-3 (Note 1)
	σ	dB	0
N_{oc} at antenna port		dBm/15kHz	-98
Precoding granularity		PRB	6
PMI delay (Note 2)		ms	8
Reporting interval		ms	8
Reporting mode			PUSCH 1-2
CodeBookSubsetRestriction bitmap			001111
PDSCH transmission mode			4
Note 1: $P_B = 1$.			
Note 2: If the UE reports in an available uplink reporting instance at subframe SF#n based on PMI estimation at a downlink SF not later than SF#(n-4), this reported PMI cannot be applied at the eNB downlink before SF#(n+4).			

Table 8.9.1.1.2.1-2: Minimum performance Single-Layer Spatial Multiplexing (FRC)

Test number	Bandwidth and MCS	Reference Channel	OCNG Pattern	Propagation Condition	Correlation Matrix and Antenna Configuration	Reference value		UE DL category
						Fraction of Maximum Throughput (%)	SNR (dB)	
1	10 MHz 64QAM 1/2	R.63 FDD	OP.1 FDD	EPA5	2x1 Low	70	13.2	0

8.9.1.1.3 Closed-loop spatial multiplexing performance (User-Specific Reference Symbols)

8.9.1.1.3.1 Single-layer Spatial Multiplexing

For single-layer transmission on antenna ports 7 or 8 upon detection of a PDCCH with DCI format 2C, the requirements are specified in Table 8.9.1.1.3.1-2 with the addition of the parameters in Table 8.9.1.1.3.1-1 and the downlink physical channel setup according to Annex C.3.2. The purpose of these tests is to verify rank-1 performance on one of the antenna ports 7 or 8, and to verify rate matching with multiple CSI reference symbol configurations with non-zero and zero transmission power.

Table 8.9.1.1.3.1-1: Test Parameters for Testing CDM-multiplexed DM RS (single layer) with multiple CSI-RS configurations

parameter		Unit	Test 1
Downlink power allocation	ρ_A	dB	0
	ρ_B	dB	0 (Note 1)
	σ	dB	-3
Beamforming model			Annex B.4.1
Cell-specific reference signals			Antenna ports 0,1
CSI reference signals			Antenna ports 15,...,18
CSI-RS periodicity and subframe offset $T_{\text{CSI-RS}} / \Delta_{\text{CSI-RS}}$		Subframes	5 / 2
CSI reference signal configuration			0
Zero-power CSI-RS configuration $I_{\text{CSI-RS}} / \text{ZeroPowerCSI-RS}$ bitmap		Subframes / bitmap	3 / 0001000000000000
N_{oc} at antenna port		dBm/15kHz	-98
Symbols for unused PRBs			OCNG (Note 4)
Number of allocated resource blocks (Note 2)		PRB	6
PDSCH transmission mode			9
Note 1: $P_B = 1$. Note 2: The modulation symbols of the signal under test are mapped onto antenna port 7 or 8. Note 3: These physical resource blocks are assigned to an arbitrary number of virtual UEs with one PDSCH per virtual UE; the data transmitted over the OCNG PDSCHs shall be uncorrelated pseudo random data, which is QPSK modulated.			

Table 8.9.1.1.3.1-2: Minimum performance for CDM-multiplexed DM RS (FRC) with multiple CSI-RS configurations

Test number	Bandwidth and MCS	Reference Channel	OCNG Pattern	Propagation Condition	Correlation Matrix and Antenna Configuration	Reference value		UE DL category
						Fraction of Maximum Throughput (%)	SNR (dB)	
1	10 MHz QPSK 1/3	R.64 FDD	OP.1 FDD	EPA5	2x1 Low	70	4.7	0

8.9.1.2 TDD (Fixed Reference Channel)

The parameters specified in Table 8.9.1.2-1 are valid for all TDD tests unless otherwise stated.

Table 8.9.1.2-1: Common Test Parameters (TDD)

Parameter	Unit	Value
Uplink downlink configuration (Note 1)		1
Special subframe configuration (Note 2)		4
Cyclic prefix		Normal
Cell ID		0
Inter-TTI Distance		1
Number of HARQ processes per component carrier	Processes	7
Maximum number of HARQ transmission		4
Redundancy version coding sequence		{0,1,2,3} for QPSK and 16QAM {0,0,1,2} for 64QAM
Number of OFDM symbols for PDCCH per component carrier	OFDM symbols	4 for 1.4 MHz bandwidth, 3 for 3 MHz and 5 MHz bandwidths, 2 for 10 MHz, 15 MHz and 20 MHz bandwidths
Precoder update granularity		Frequency domain: 1 PRG Time domain: 1 ms for Transmission mode 9
ACK/NACK feedback mode		Multiplexing
Note 1: as specified in Table 4.2-2 in TS 36.211 [4].		
Note 2: as specified in Table 4.2-1 in TS 36.211 [4].		

8.9.1.2.1 Transmit diversity performance (Cell-Specific Reference Symbols)

8.9.1.2.1.1 Minimum Requirement 2 Tx Antenna Port

The requirements are specified in Table 8.9.1.2.1.1-2, with the addition of the parameters in Table 8.9.1.2.1.1-1 and the downlink physical channel setup according to Annex C.3.2. The purpose is to verify the performance of transmit diversity (SFBC) with 2 transmitter antennas.

Table 8.9.1.2.1.1-1: Test Parameters for Transmit diversity Performance (FRC)

Parameter	Unit	Test 1-2
Downlink power allocation	ρ_A	dB
	ρ_B	dB
	σ	dB
N_{oc} at antenna port	dBm/15kHz	-98
ACK/NACK feedback mode		Multiplexing
PDSCH transmission mode		2
Note 1: $P_B = 1$		

Table 8.9.1.2.1.1-2: Minimum performance Transmit Diversity (FRC)

Test number	Bandwidth	Reference Channel	OCNG Pattern	Propagation Condition	Correlation Matrix and Antenna Configuration	Reference value		UE DL category
						Fraction of Maximum Throughput (%)	SNR (dB)	
1	10 MHz 16QAM 1/2	R.62 TDD	OP.1 TDD	EPA5	2x1 Low	70	8.8	0

8.9.1.2.2 Closed-loop spatial multiplexing performance (Cell-Specific Reference Symbols)

8.9.1.2.2.1 Minimum Requirement Single-Layer Spatial Multiplexing 2 Tx Antenna Port

The requirements are specified in Table 8.9.1.2.2.1-2, with the addition of the parameters in Table 8.9.1.2.2.1-1 and the downlink physical channel setup according to Annex C.3.2. The purpose of these tests is to verify the closed loop rank-one performance with frequency selective precoding.

Table 8.9.1.2.2.1-1: Test Parameters for Single-Layer Spatial Multiplexing (FRC)

Parameter	Unit	Test 1	
Downlink power allocation	ρ_A	dB	-3
	ρ_B	dB	-3 (Note 1)
	σ	dB	0
N_{oc} at antenna port	dBm/15kHz	-98	
Precoding granularity	PRB	6	
PMI delay (Note 2)	ms	10 or 11	
Reporting interval	ms	1 or 4 (Note 3)	
Reporting mode		PUSCH 1-2	
CodeBookSubsetRestriction bitmap		001111	
ACK/NACK feedback mode		Multiplexing	
PDSCH transmission mode		4	
Note 1: $P_B = 1$. Note 2: If the UE reports in an available uplink reporting instance at subframe SF#n based on PMI estimation at a downlink SF not later than SF#(n-4), this reported PMI cannot be applied at the eNB downlink before SF#(n+4). Note 3: For Uplink - downlink configuration 1 the reporting interval will alternate between 1ms and 4ms.			

Table 8.9.1.2.2.1-2: Minimum performance Single-Layer Spatial Multiplexing (FRC)

Test number	Bandwidth	Reference Channel	OCNG Pattern	Propagation Condition	Correlation Matrix and Antenna Configuration	Reference value		UE DL category
						Fraction of Maximum Throughput (%)	SNR (dB)	
1	10 MHz 64QAM 1/2	R.63 TDD	OP.1 TDD	EPA5	2x1 Low	70	13.1	0

8.9.1.2.3 Closed-loop spatial multiplexing performance (User-Specific Reference Symbols)

8.9.1.2.3.1 Single-layer Spatial Multiplexing

For single-layer transmission on antenna ports 7 or 8 upon detection of a PDCCH with DCI format 2C, the requirements are specified in Table 8.9.1.2.3.1-2 with the addition of the parameters in Table 8.9.1.2.3.1-1 and the downlink physical channel setup according to Annex C.3.2. The purpose of these tests is to verify rank-1 performance on one of the

antenna ports 7 or 8, and to verify rate matching with multiple CSI reference symbol configurations with non-zero and zero transmission power.

Table 8.9.1.2.3.1-1: Test Parameters for Testing CDM-multiplexed DM RS (single layer) with multiple CSI-RS configurations

Parameter	Unit	Test 1	
Downlink power allocation	ρ_A	dB	0
	ρ_B	dB	0 (Note 1)
	σ	dB	-3
Cell-specific reference signals		Antenna ports 0,1	
CSI reference signals		Antenna ports 15,...,18	
Beamforming model		Annex B.4.1	
CSI-RS periodicity and subframe offset $T_{\text{CSI-RS}} / \Delta_{\text{CSI-RS}}$	Subframes	5 / 4	
CSI reference signal configuration		1	
Zero-power CSI-RS configuration $l_{\text{CSI-RS}} / \text{ZeroPowerCSI-RS}$ bitmap	Subframes / bitmap	4 / 0010000100000000	
N_{oc} at antenna port	dBm/15kHz	-98	
Symbols for unused PRBs		OCNG (Note 4)	
Number of allocated resource blocks (Note 2)	PRB	6	
Simultaneous transmission		No	
PDSCH transmission mode		9	
Note 1: $P_B = 1$. Note 2: The modulation symbols of the signal under test are mapped onto antenna port 7 or 8. Note 3: These physical resource blocks are assigned to an arbitrary number of virtual UEs with one PDSCH per virtual UE; the data transmitted over the OCNG PDSCHs shall be uncorrelated pseudo random data, which is QPSK modulated.			

Table 8.9.1.2.3.1-2: Minimum performance for CDM-multiplexed DM RS without simultaneous transmission (FRC) with multiple CSI-RS configurations

Test number	Bandwidth and MCS	Reference Channel	OCNG Pattern	Propagation Condition	Correlation Matrix and Antenna Configuration	Reference value		UE DL category
						Fraction of Maximum Throughput (%)	SNR (dB)	
1	10 MHz QPSK 1/3	R.64 TDD	OP.1 TDD	EPA5	2x1 Low	70	4.5	0

8.9.2 PHICH

8.9.2.1 FDD and half-duplex FDD

8.9.2.1.1 Transmit diversity performance

For the parameters specified in Table 8.5.1-1 the average probability of a miss-detecting ACK for NACK (P_{m-an}) shall be below the specified value in Table 8.9.2.1.1-1. The downlink physical setup is in accordance with Annex C.3.2.

Table 8.9.2.1.1-1: Minimum performance PHICH

Test number	Bandwidth	Reference Channel	OCNG Pattern	Propagation Condition	Antenna configuration and correlation Matrix	Reference value	
						Pm-an (%)	SNR (dB)
1	10 MHz	R.19	OP.1 FDD	EPA5	2 x 1 Low	0.1	8.6

8.9.2.2 TDD

8.9.2.2.1 Transmit diversity performance

For the parameters specified in Table 8.5.2-1 the average probability of a miss-detecting ACK for NACK (P_{m-an}) shall be below the specified value in Table 8.9.2.2.1-1. The downlink physical setup is in accordance with Annex C.3.2.

Table 8.9.2.2.1-1: Minimum performance PHICH

Test number	Bandwidth	Reference Channel	OCNG Pattern	Propagation Condition	Antenna configuration and correlation Matrix	Reference value	
						Pm-an (%)	SNR (dB)
1	10 MHz	R.19	OP.1 TDD	EPA5	2 x 1 Low	0.1	8.6

8.9.3 PBCH

8.9.3.1 FDD and half-duplex FDD

8.9.3.1.1 Transmit diversity performance

For the parameters specified in Table 8.6.1-1 the average probability of a miss-detected PBCH (P_{m-bch}) shall be below the specified value in Table 8.9.3.1.1-1. The downlink physical setup is in accordance with Annex C.3.2.

Table 8.9.3.1.1-1: Minimum performance PBCH

Test number	Bandwidth	Reference Channel	Propagation Condition	Antenna configuration and correlation Matrix	Reference value	
					Pm-bch (%)	SNR (dB)
1	1.4 MHz	R.22	EPA5	2 x 1 Low	1	-1.3

8.9.3.2 TDD

8.9.3.2.1 Transmit diversity performance

For the parameters specified in Table 8.6.2-1 the average probability of a miss-detected PBCH (Pm-bch) shall be below the specified value in Table 8.9.3.2.1-1. The downlink physical setup is in accordance with Annex C.3.2.

Table 8.9.3.2.1-1: Minimum performance PBCH

Test number	Bandwidth	Reference Channel	Propagation Condition	Antenna configuration and correlation Matrix	Reference value	
					Pm-bch (%)	SNR (dB)
1	1.4 MHz	R.22	EPA5	2 x 1 Low	1	-1.7

9 Reporting of Channel State Information

9.1 General

This section includes requirements for the reporting of channel state information (CSI). For all test cases in this section, the definition of SNR and SINR are in accordance with the one given in clause 8.1.1.

For the performance requirements specified in this clause, it is assumed that $N_{RX}=2$ unless otherwise stated.

Unless otherwise stated, 4-bit CQI Table in Table 7.2.3-1 in TS 36.213 [6], and Modulation and TBS index table in Table 7.1.7.1-1 for PDSCH in TS 36.213 [6] are applied in all the CSI requirements.

9.1.1 Applicability of requirements

9.1.1.1 Applicability of requirements for different channel bandwidths

In Clause 9 the test cases may be defined with different channel bandwidth to verify the same CSI requirement.

Test cases defined for 5MHz channel bandwidth that reference this clause are applicable to UEs that support only Band 31.

9.1.1.2 Applicability and test rules for different CA configurations and bandwidth combination sets

The performance requirement for CA CQI tests in Clause 9 are defined independent of CA configurations and bandwidth combination sets specified in Clause 5.6A.1. For UEs supporting different CA configurations and bandwidth combination sets, the applicability and test rules are defined for the tests for 2 DL CCs in Table 9.1.1.2-1 and 3 DL CCs in Table 9.1.1.2-2. For simplicity, CA configuration below refers to combination of CA configuration and bandwidth combination set.

Table 9.1.1.2-1: Applicability and test rules for CA UE CQI tests with 2 DL CCs

Tests	CA capability where the tests apply	CA configuration from the selected CA capability where the tests apply	CA Bandwidth combination to be tested in priority order
CA tests with 2CCs in Clause 9.6.1.1	Any of one of the supported CA capabilities	Any one of the supported FDD CA configurations	10+10 MHz, 20+20 MHz, 5+5 MHz, and 10MHz+5MHz.
CA tests with 2CCs in Clause 9.6.1.2	Any of one of the supported CA capabilities with largest aggregated CA bandwidth combination	Any one of the supported TDD CA configurations with largest aggregated CA bandwidth combination	Largest aggregated CA bandwidth combination
Note 1: The applicability and test rules are specified in this table, unless otherwise stated. Note 2: Number of the supported bandwidth combinations to be tested from each selected CA configuration is 1. Note 3: A single Uplink CC is configured for all tests			

Table 9.1.1.2-2: Applicability and test rules for CA UE CQI tests with 3 DL CCs

Tests	CA capability where the tests apply	CA configuration from the selected CA capability where the tests apply	CA Bandwidth combination to be tested in priority order
CA tests with 3CCs in Clause 9.6.1.1	Any of one of the supported CA capabilities with largest aggregated CA bandwidth combination	Any one of the supported FDD CA configurations with largest aggregated CA bandwidth combination	Largest aggregated CA bandwidth combination
CA tests with 3CCs in Clause 9.6.1.2	Any of one of the supported CA capabilities with largest aggregated CA bandwidth combination	Any one of the supported TDD CA configurations with largest aggregated CA bandwidth combination	Largest aggregated CA bandwidth combination
Note 1: The applicability and test rules are specified in this table, unless otherwise stated. Note 2: Number of the supported bandwidth combinations to be tested from each selected CA configuration is 1. Note 3: A single Uplink CC is configured for all tests			

9.1.1.2A Applicability and test rules for different TDD-FDD CA configurations and bandwidth combination sets

The performance requirement for TDD-FDD CA CQI tests in Clause 9 are defined independent of CA configurations and bandwidth combination sets specified in Clause 5.6A.1. For UEs supporting different CA configurations and bandwidth combination sets, the applicability and test rules are defined for the tests for 2 DL TDD-FDD CA in Table 9.1.1.2A-1 and for 3 DL TDD-FDD CA in Table 9.1.1.2A-2. For simplicity, CA configuration below refers to combination of CA configuration and bandwidth combination set.

Table 9.1.1.2A-1: Applicability and test rules for CA UE CQI tests for TDD-FDD CA with 2 DL CCs

Tests	CA capability where the tests apply	CA configuration from the selected CA capability where the tests apply	CA Bandwidth combination to be tested in priority order
CA tests with 2CCs in Clause 9.6.1.3	Any of one of the supported CA capabilities	Any one of the supported TDD-FDD CA configurations with FDD PCell with largest aggregated CA bandwidth combination	Largest aggregated CA bandwidth combination
CA tests with 2CCs in Clause 9.6.1.4	Any of one of the supported CA capabilities	Any one of the supported TDD-FDD CA configurations with TDD PCell with largest aggregated CA bandwidth combination	Largest aggregated CA bandwidth combination
Note 1: The applicability and test rules are specified in this table, unless otherwise stated.			
Note 2: Number of the supported bandwidth combinations to be tested from each selected CA configuration is 1.			
Note 3: A single Uplink CC is configured for all tests			

Table 9.1.1.2A-2: Applicability and test rules for CA UE CQI tests for TDD-FDD CA with 3 DL CCs

Tests	CA capability where the tests apply	CA configuration from the selected CA capability where the tests apply	CA Bandwidth combination to be tested in priority order
CA tests with 3CCs in Clause 9.6.1.3	Any of one of the supported CA capabilities	Any one of the supported TDD-FDD CA configurations with FDD PCell with largest aggregated CA bandwidth combination	Largest aggregated CA bandwidth combination
CA tests with 3CCs in Clause 9.6.1.4	Any of one of the supported CA capabilities	Any one of the supported TDD-FDD CA configurations with TDD PCell with largest aggregated CA bandwidth combination	Largest aggregated CA bandwidth combination
Note 1: The applicability and test rules are specified in this table, unless otherwise stated.			
Note 2: Number of the supported bandwidth combinations to be tested from each selected CA configuration is 1.			
Note 3: A single Uplink CC is configured for all tests			

9.1.1.3 Test coverage for different number of component carriers

For FDD CA tests specified in 9.6.1.1, among all supported CA capabilities, if corresponding CA tests with the largest number of CCs supported by the UE are tested, the test coverage can be considered fulfilled without executing the CA tests with less than the largest number of CCs supported by the UE.

For TDD CA tests specified in 9.6.1.2, among all supported CA capabilities, if corresponding CA tests with the largest number of CCs supported by the UE are tested, the test coverage can be considered fulfilled without executing the CA tests with less than the largest number of CCs supported by the UE.

For TDD FDD CA tests specified in 9.6.1.3 and 9.6.1.4, among all supported CA capabilities, if corresponding CA tests with the largest number of CCs supported by the UE are tested, the test coverage can be considered fulfilled without executing the TDD FDD CA tests with less than the largest number of CCs supported by the UE.

9.2 CQI reporting definition under AWGN conditions

The reporting accuracy of the channel quality indicator (CQI) under frequency non-selective conditions is determined by the reporting variance and the BLER performance using the transport format indicated by the reported CQI median. The purpose is to verify that the reported CQI values are in accordance with the CQI definition given in TS 36.213 [6]. To account for sensitivity of the input SNR the reporting definition is considered to be verified if the reporting accuracy is met for at least one of two SNR levels separated by an offset of 1 dB.

9.2.1 Minimum requirement PUCCH 1-0 (Cell-Specific Reference Symbols)

9.2.1.1 FDD

The following requirements apply to UE Category ≥ 1 . For the parameters specified in Table 9.2.1.1-1 and Table 9.2.1.1-2, and using the downlink physical channels specified in tables C.3.2-1 and C.3.2-2, the reported CQI value according to RC.1 FDD / RC.14 FDD in Table A.4-1 shall be in the range of ± 1 of the reported median more than 90% of the time. If the PDSCH BLER using the transport format indicated by median CQI is less than or equal to 0.1, the BLER using the transport format indicated by the (median CQI + 1) shall be greater than 0.1. If the PDSCH BLER using the transport format indicated by the median CQI is greater than 0.1, the BLER using transport format indicated by (median CQI – 1) shall be less than or equal to 0.1.

The applicability of the requirement with 5MHz bandwidth as specified in Table 9.2.1.1-2 is defined in 9.1.1.1.

Table 9.2.1.1-1: PUCCH 1-0 static test (FDD)

Parameter	Unit	Test 1		Test 2	
Bandwidth	MHz	10			
PDSCH transmission mode		1			
Downlink power allocation	ρ_A	dB		0	
	ρ_B	dB		0	
	σ	dB		0	
Propagation condition and antenna configuration		AWGN (1 x 2)			
SNR (Note 2)	dB	0	1	6	7
$\hat{I}_{or}^{(j)}$	dB[mW/15kHz]	-98	-97	-92	-91
$N_{oc}^{(j)}$	dB[mW/15kHz]	-98		-98	
Max number of HARQ transmissions		1			
Physical channel for CQI reporting		PUCCH Format 2			
PUCCH Report Type		4			
Reporting periodicity	ms	$N_{pd} = 5$			
<i>cqi-pmi-ConfigurationIndex</i>		6			
Note 1:	Reference measurement channel RC.1 FDD according to Table A.4-1 with one sided dynamic OCNG Pattern OP.1 FDD as described in Annex A.5.1.1, except for category 1 UE use RC.4 FDD with two sided dynamic OCNG Pattern OP.2 FDD as described in Annex A.5.1.2.				
Note 2:	For each test, the minimum requirements shall be fulfilled for at least one of the two SNR(s) and the respective wanted signal input level.				

Table 9.2.1.1-2: PUCCH 1-0 static test (FDD 5MHz)

Parameter		Unit	Test 1		Test 2	
Bandwidth		MHz	5			
PDSCH transmission mode			1			
Downlink power allocation	ρ_A	dB	0			
	ρ_B	dB	0			
	σ	dB	0			
Propagation condition and antenna configuration			AWGN (1 x 2)			
SNR (Note 2)		dB	0	1	6	7
$\hat{I}_{or}^{(j)}$		dB[mW/15kHz]	-98	-97	-92	-91
$N_{oc}^{(j)}$		dB[mW/15kHz]	-98		-98	
Max number of HARQ transmissions			1			
Physical channel for CQI reporting			PUCCH Format 2			
PUCCH Report Type			4			
Reporting periodicity		ms	$N_{pd} = 5$			
<i>cqi-pmi-ConfigurationIndex</i>			6			
<p>Note 1: Reference measurement channel RC.14 FDD according to Table A.4-1 with one sided dynamic OCNG Pattern OP.1 FDD as described in Annex A.5.1.1, except for category 1 UE use RC.15 FDD with two sided dynamic OCNG Pattern OP.2 FDD as described in Annex A.5.1.2.</p> <p>Note 2: For each test, the minimum requirements shall be fulfilled for at least one of the two SNR(s) and the respective wanted signal input level.</p>						

9.2.1.2 TDD

The following requirements apply to UE Category ≥ 1 . For the parameters specified in Table 9.2.1.2-1, and using the downlink physical channels specified in tables C.3.2-1 and C.3.2-2, the reported CQI value according to RC.1 TDD in Table A.4-1 shall be in the range of ± 1 of the reported median more than 90% of the time. If the PDSCH BLER using the transport format indicated by median CQI is less than or equal to 0.1, the BLER using the transport format indicated by the (median CQI + 1) shall be greater than 0.1. If the PDSCH BLER using the transport format indicated by the median CQI is greater than 0.1, the BLER using transport format indicated by (median CQI – 1) shall be less than or equal to 0.1.

Table 9.2.1.2-1: PUCCH 1-0 static test (TDD)

Parameter		Unit	Test 1		Test 2	
Bandwidth		MHz			10	
PDSCH transmission mode					1	
Uplink downlink configuration					2	
Special subframe configuration					4	
Downlink power allocation	ρ_A	dB			0	
	ρ_B	dB			0	
	σ	dB			0	
Propagation condition and antenna configuration			AWGN (1 x 2)			
SNR (Note 2)		dB	0	1	6	7
$\hat{I}_{or}^{(j)}$		dB[mW/15kHz]	-98	-97	-92	-91
$N_{oc}^{(j)}$		dB[mW/15kHz]	-98		-98	
Max number of HARQ transmissions			1			
Physical channel for CQI reporting			PUSCH (Note 3)			
PUCCH Report Type			4			
Reporting periodicity		ms	$N_{pd} = 5$			
<i>cqi-pmi-ConfigurationIndex</i>			3			
ACK/NACK feedback mode			Multiplexing			
Note 1:		Reference measurement channel RC.1 TDD according to Table A.4-1 with one sided dynamic OCNG Pattern OP.1 TDD as described in Annex A.5.2.1, except for category 1 UE use RC.4 TDD with two sided dynamic OCNG Pattern OP.2 TDD as described in Annex A.5.2.2.				
Note 2:		For each test, the minimum requirements shall be fulfilled for at least one of the two SNR(s) and the respective wanted signal input level.				
Note 3:		To avoid collisions between CQI reports and HARQ-ACK it is necessary to report both on PUSCH instead of PUCCH. PDCCH DCI format 0 shall be transmitted in downlink SF#3 and #8 to allow periodic CQI to multiplex with the HARQ-ACK on PUSCH in uplink subframe SF#7 and #2.				

9.2.1.3 FDD (CSI measurements in case two CSI subframe sets are configured)

The following requirements apply to UE Category ≥ 1 . For the parameters specified in Table 9.2.1.3-1, and using the downlink physical channels specified in tables C.3.2-1 for Cell 1, C.3.3-1 for Cell 2 and C.3.2-2, the reported CQI value according to RC.2 FDD / RC.6 FDD in Table A.4-1 in subframes overlapping with aggressor cell ABS and non-ABS subframes shall be in the range of ± 1 of the reported median more than 90% of the time. If the PDSCH BLER in non-ABS subframes using the transport format indicated by median CQI obtained by reports in CSI subframe sets $C_{CSI,1}$ is less than or equal to 0.1, the BLER in non-ABS subframes using the transport format indicated by the (median CQI + 1) shall be greater than 0.1. If the PDSCH BLER in non-ABS subframes using the transport format indicated by the median CQI is greater than 0.1, the BLER in non-ABS subframes using transport format indicated by (median CQI – 1) shall be less than or equal to 0.1. The value of the median CQI obtained by reports in CSI subframe sets $C_{CSI,0}$ minus the median CQI obtained by reports in CSI subframe sets $C_{CSI,1}$ shall be larger than or equal to 2 and less than or equal to 5 in Test 1 and shall be larger than or equal to 0 and less than or equal to 1 in Test 2.

Table 9.2.1.3-1: PUCCH 1-0 static test (FDD)

Parameter		Unit	Test 1			Test 2		
			Cell 1	Cell 2		Cell 1	Cell 2	
Bandwidth		MHz	10			10		
PDSCH transmission mode			2	Note 10		2	Note 10	
Downlink power allocation	ρ_A	dB	-3			-3		
	ρ_B	dB	-3			-3		
	σ	dB	0			0		
Propagation condition and antenna configuration			Clause B.1 (2x2)			Clause B.1 (2x2)		
\hat{E}_s/N_{oc2} (Note 1)		dB	4	5	6	4	5	-12
$N_{oc}^{(j)}$ at antenna port	$N_{oc1}^{(j)}$	dBm/15kHz	-102 (Note 7)		N/A	-98(Note 7)		N/A
	$N_{oc2}^{(j)}$	dBm/15kHz	-98 (Note 8)		N/A	-98(Note 8)		N/A
	$N_{oc3}^{(j)}$	dBm/15kHz	-94.8 (Note 9)		N/A	-98(Note 9)		N/A
$\hat{I}_{or}^{(j)}$		dB[mW/15kHz]	-94	-93	-92	-94	-93	-110
Subframe Configuration			Non-MBSFN		Non-MBSFN	Non-MBSFN		Non-MBSFN
Cell Id			0		1	0		1
Time Offset between Cells		μ s	2.5 (synchronous cells)			2.5 (synchronous cells)		
ABS pattern (Note 2)			N/A		01010101 01010101 01010101 01010101 01010101	N/A		01010101 01010101 01010101 01010101 01010101
RLM/RRM Measurement Subframe Pattern (Note 4)			00000100 00000100 00000100 00000100 00000100		N/A	00000100 00000100 00000100 00000100 00000100		N/A
CSI Subframe Sets (Note 3)	$C_{CSI,0}$		01010101 01010101 01010101 01010101 01010101		N/A	01010101 01010101 01010101 01010101 01010101		N/A
	$C_{CSI,1}$		10101010 10101010 10101010 10101010 10101010		N/A	10101010 10101010 10101010 10101010 10101010		N/A
Number of control OFDM symbols			3			3		
Max number of HARQ transmissions			1			1		
Physical channel for $C_{CSI,0}$ CQI reporting			PUCCH Format 2			PUCCH Format 2		
Physical channel for $C_{CSI,1}$ CQI reporting			PUSCH (Note 12)			PUSCH (Note 12)		
PUCCH Report Type			4			4		
Reporting periodicity		Ms	$N_{pd} = 5$			$N_{pd} = 5$		
$cqi-pmi-ConfigurationIndex_{C_{CSI,0}}$ (Note 13)			6	N/A		6	N/A	
$cqi-pmi-ConfigurationIndex2_{C_{CSI,1}}$ (Note 14)			5	N/A		5	N/A	

Note 1:	For each test, the minimum requirements shall be fulfilled for at least one of the two SNR(s) and the respective wanted signal input level.
Note 2:	ABS pattern as defined in [9].
Note 3:	Time-domain measurement resource restriction pattern for PCell measurements as defined in [7]
Note 4:	As configured according to the time-domain measurement resource restriction pattern for CSI measurements defined in [7]
Note 5:	Time-domain measurement resource restriction pattern for PCell measurements as defined in [7]
Note 6:	Cell 1 is the serving cell. Cell 2 is the aggressor cell. The number of the CRS ports in Cell1 and Cell2 is the same.
Note 7:	This noise is applied in OFDM symbols #1, #2, #3, #5, #6, #8, #9, #10,#12, #13 of a subframe overlapping with the aggressor ABS.
Note 8:	This noise is applied in OFDM symbols #0, #4, #7, #11 of a subframe overlapping with the aggressor ABS.
Note 9:	This noise is applied in all OFDM symbols of a subframe overlapping with aggressor non-ABS.
Note 10:	Downlink physical channel setup in Cell 2 in accordance with Annex C.3.3 applying OCNG pattern as defined in Annex A.5.1.5
Note 11:	Reference measurement channel in Cell 1 RC.2 FDD according to Table A.4-1 for UE Category 2-8 with one sided dynamic OCNG Pattern OP.1 FDD as described in Annex A.5.1.1, and RC.6 FDD according to Table A.4-1 for Category 1 with one/two sided dynamic OCNG Pattern OP. 1/2 FDD as described in Annex A.5.1.1 and A.5.1.2.
Note 12:	To avoid collisions between HARQ-ACK and wideband CQI it is necessary to report both on PUSCH instead of PUCCH. PDCCH DCI format 0 shall be transmitted in downlink SF#4 and #9 to allow periodic CQI to multiplex with the HARQ-ACK on PUSCH in uplink subframe SF#8 and #3.
Note 13:	<i>cqi-pmi-ConfigurationIndex</i> is applied for $C_{CSI,0}$.
Note 14:	<i>cqi-pmi-ConfigurationIndex2</i> is applied for $C_{CSI,1}$.

9.2.1.4 TDD (CSI measurements in case two CSI subframe sets are configured)

The following requirements apply to UE Category ≥ 1 . For the parameters specified in Table 9.2.1.4-1, and using the downlink physical channels specified in tables C.3.2-1 for Cell 1, C.3.3-1 for Cell 2 and C.3.2-2, the reported CQI value according to RC.2 TDD / RC.6 TDD in Table A.4-1 in subframes overlapping with aggressor cell ABS and non-ABS subframes shall be in the range of ± 1 of the reported median more than 90% of the time. If the PDSCH BLER in non-ABS subframes using the transport format indicated by median CQI obtained by reports in CSI subframe sets $C_{CSI,1}$ is less than or equal to 0.1, the BLER in non-ABS subframes using the transport format indicated by the (median CQI + 1) shall be greater than 0.1. If the PDSCH BLER in non-ABS subframes using the transport format indicated by the median CQI is greater than 0.1, the BLER in non-ABS subframes using transport format indicated by (median CQI – 1) shall be less than or equal to 0.1. The value of the median CQI obtained by reports in CSI subframe sets $C_{CSI,0}$ minus the median CQI obtained by reports in CSI subframe sets $C_{CSI,1}$ shall be larger than or equal to 2 and less than or equal to 5 in Test 1 and shall be larger than or equal to 0 and less than or equal to 1 in Test 2.

Table 9.2.1.4-1: PUCCH 1-0 static test (TDD)

Parameter	Unit	Test 1			Test 2			
		Cell 1		Cell 2	Cell 1		Cell 2	
Bandwidth	MHz	10			10			
PDSCH transmission mode		2		Note 10	2		Note 10	
Uplink downlink configuration		1			1			
Special subframe configuration		4			4			
Downlink power allocation	ρ_A	dB			-3			
	ρ_B	dB			-3			
	σ	dB			0			
Propagation condition and antenna configuration		Clause B.1 (2x2)			Clause B.1 (2x2)			
\hat{E}_s / N_{oc2} (Note 1)	dB	4	5	6	4	5	-12	
$N_{oc}^{(j)}$ at antenna port	$N_{oc1}^{(j)}$	dBm/15kHz		-102 (Note 7)	N/A		-98 (Note 7)	N/A
	$N_{oc2}^{(j)}$	dBm/15kHz		-98 (Note 8)	N/A		-98 (Note 8)	N/A
	$N_{oc3}^{(j)}$	dBm/15kHz		-94.8 (Note 9)	N/A		-98 (Note 9)	N/A
$\hat{I}_{or}^{(j)}$	dB[mW/15kHz]	-94	-93	-92	-94	-93	-110	
Subframe Configuration		Non-MBSFN		Non-MBSFN	Non-MBSFN		Non-MBSFN	
Cell Id		0		1	0		1	
Time Offset between Cells	μ s	2.5 (synchronous cells)			2.5 (synchronous cells)			
ABS pattern (Note 2)		N/A		0100010001 0100010001	N/A		0100010001 0100010001	
RLM/RRM Measurement Subframe Pattern (Note 4)		0000000001 0000000001		N/A	0000000001 0000000001		N/A	
CSI Subframe Sets (Note 3)	$C_{CSI,0}$	0100010001 0100010001		N/A	0100010001 0100010001		N/A	
	$C_{CSI,1}$	1000101000 1000101000		N/A	1000101000 1000101000		N/A	
Number of control OFDM symbols		3			3			
Max number of HARQ transmissions		1			1			
Physical channel for $C_{CSI,0}$ CQI reporting		PUCCH Format 2			PUCCH Format 2			
Physical channel for $C_{CSI,1}$ CQI reporting		PUSCH (Note 12)			PUSCH			
PUCCH Report Type		4			4			
Reporting periodicity	ms	$N_{pd} = 5$			$N_{pd} = 5$			
$cqi-pmi-ConfigurationIndex$ $C_{CSI,0}$ (Note 13)		3		N/A	3		N/A	
$cqi-pmi-ConfigurationIndex2$ $C_{CSI,1}$ (Note 14)		4		N/A	4		N/A	
ACK/NACK feedback mode		Multiplexing			Multiplexing			

Note 1:	For each test, the minimum requirements shall be fulfilled for at least one of the two SNR(s) and the respective wanted signal input level.
Note 2:	ABS pattern as defined in [9].
Note 3:	Time-domain measurement resource restriction pattern for PCell measurements as defined in [7]
Note 4:	As configured according to the time-domain measurement resource restriction pattern for CSI measurements defined in [7].
Note 5:	Time-domain measurement resource restriction pattern for PCell measurements as defined in [7]
Note 6:	Cell 1 is the serving cell. Cell 2 is the aggressor cell. The number of the CRS ports in Cell1 and Cell2 is the same.
Note 7:	This noise is applied in OFDM symbols #1, #2, #3, #5, #6, #8, #9, #10,#12, #13 of a subframe overlapping with the aggressor ABS.
Note 8:	This noise is applied in OFDM symbols #0, #4, #7, #11 of a subframe overlapping with the aggressor ABS
Note 9:	This noise is applied in all OFDM symbols of a subframe overlapping with aggressor non-ABS.
Note 10:	Downlink physical channel setup in Cell 2 in accordance with Annex C.3.3 applying OCNG pattern as defined in Annex A.5.2.5
Note 11:	Reference measurement channel in Cell 1 RC.2 TDD according to Table A.4-1 for UE Category ≥ 2 with one sided dynamic OCNG Pattern OP.1 TDD as described in Annex A.5.2.1, and RC.6 TDD according to Table A.4-1 for Category 1 with one/two sided dynamic OCNG Pattern OP.1/2 TDD as described in Annex A.5.2.1 and Annex A.5.2.2.
Note 12:	To avoid collisions between HARQ-ACK and wideband CQI it is necessary to report both on PUSCH instead of PUCCH. PDCCH DCI format 0 shall be transmitted in downlink SF#4 and #9 to allow periodic CQI to multiplex with the HARQ-ACK on PUSCH in uplink subframe SF#8 and #3.
Note 13:	<i>cqi-pmi-ConfigurationIndex</i> is applied for $C_{CSI,0}$.
Note 14:	<i>cqi-pmi-ConfigurationIndex2</i> is applied for $C_{CSI,1}$.

9.2.1.5 FDD (CSI measurements in case two CSI subframe sets are configured and with CRS assistance information)

The following requirements apply to UE Category ≥ 2 . For the parameters specified in Table 9.2.1.5-1, and using the downlink physical channels specified in tables C.3.2-1 for Cell 1, C.3.3-2 for Cell 2 and Cell 3, and C.3.2-2, the reported CQI value according to RC.2 FDD in Table A.4-1 in subframes overlapping with aggressor cell ABS and non-ABS subframes shall be in the range of ± 1 of the reported median more than 90% of the time.

For test 1 and test 2, if the PDSCH BLER in ABS subframes using the transport format indicated by median CQI obtained by reports in CSI subframe sets $C_{CSI,0}$ is less than or equal to 0.1, the BLER in ABS subframes using the transport format indicated by the (median CQI + 1) shall be greater than 0.1. If the PDSCH BLER in ABS subframes using the transport format indicated by the median CQI is greater than 0.1, the BLER in ABS subframes using transport format indicated by (median CQI – 1) shall be less than or equal to 0.1.

For test 2, if the PDSCH BLER in non-ABS subframes using the transport format indicated by median CQI obtained by reports in CSI subframe sets $C_{CSI,1}$ is less than or equal to 0.1, the BLER in non-ABS subframes using the transport format indicated by the (median CQI + 2) shall be greater than 0.1. If the PDSCH BLER in non-ABS subframes using the transport format indicated by the median CQI is greater than 0.1, the BLER in non-ABS subframes using transport format indicated by (median CQI – 1) shall be less than or equal to 0.1.

Table 9.2.1.5-1: PUCCH 1-0 static test (FDD)

Parameter		Unit	Test 1			Test 2		
			Cell 1		Cell 2 and 3	Cell 1		Cell 2 and 3
Bandwidth		MHz	10			10		
PDSCH transmission mode			2		Note 10	2		Note 10
Downlink power allocation	ρ_A	dB	-3			-3		
	ρ_B	dB	-3			-3		
	σ	dB	0			0		
Propagation condition and antenna configuration			Clause B.1 (2x2)			Clause B.1 (2x2)		
\widehat{E}_s/N_{oc2} (Note 1)		dB	4	5	Cell 2: 12 Cell 3: 10	13	14	Cell 2: 12 Cell 3: 10
$N_{oc}^{(j)}$ at antenna port	$N_{oc1}^{(j)}$	dBm/15kHz	-98 (Note 7)		N/A	-98 (Note 7)		N/A
	$N_{oc2}^{(j)}$	dBm/15kHz	-98 (Note 8)		N/A	-98 (Note 8)		N/A
	$N_{oc3}^{(j)}$	dBm/15kHz	-93 (Note 9)		N/A	-93 (Note 9)		N/A
Subframe Configuration			Non-MBSFN		Non-MBSFN	Non-MBSFN		Non-MBSFN
Cell Id			0		Cell 2: 6 Cell 3: 1	0		Cell 2: 6 Cell 3: 1
Time Offset between Cells		μ s	Cell 2: 3 usec Cell 3: -1usec			Cell 2: 3 usec Cell 3: -1usec		
Frequency Shift between Cells		Hz	Cell 2: 300Hz Cell 3: -100Hz			Cell 2: 300Hz Cell 3: -100Hz		
ABS pattern (Note 2)			N/A		01010101 01010101 01010101 01010101 01010101	N/A		01010101 01010101 01010101 01010101 01010101
RLM/RRM Measurement Subframe Pattern (Note 4)			00000100 00000100 00000100 00000100 00000100		N/A	00000100 00000100 00000100 00000100 00000100		N/A
CSI Subframe Sets (Note 3)	$C_{CSI,0}$		01010101 01010101 01010101 01010101 01010101		N/A	01010101 01010101 01010101 01010101 01010101		N/A
	$C_{CSI,1}$		10101010 10101010 10101010 10101010 10101010		N/A	10101010 10101010 10101010 10101010 10101010		N/A
Number of control OFDM symbols			3			3		
Max number of HARQ transmissions			1			1		
Physical channel for $C_{CSI,0}$ CQI reporting			PUCCH Format 2			PUCCH Format 2		
Physical channel for $C_{CSI,1}$ CQI reporting			PUSCH (Note 12)			PUSCH (Note 12)		
PUCCH Report Type			4			4		
Reporting periodicity		Ms	$N_{pd} = 5$			$N_{pd} = 5$		
$cqi-pmi-ConfigurationIndex$ $C_{CSI,0}$ (Note 13)			6		N/A	6		N/A
$cqi-pmi-ConfigurationIndex2$ $C_{CSI,1}$ (Note 14)			5		N/A	5		N/A

Note 1:	For each test, the minimum requirements shall be fulfilled for at least one of the two SNR(s) and the respective wanted signal input level.
Note 2:	ABS pattern as defined in [9].
Note 3:	Time-domain measurement resource restriction pattern for PCell measurements as defined in [7]
Note 4:	As configured according to the time-domain measurement resource restriction pattern for CSI measurements defined in [7]
Note 5:	Time-domain measurement resource restriction pattern for PCell measurements as defined in [7]
Note 6:	Cell 1 is the serving cell. Cell 2 and Cell 3 are the aggressor cells. The number of the CRS ports in Cell1, Cell2, and Cell3 are the same.
Note 7:	This noise is applied in OFDM symbols #1, #2, #3, #5, #6, #8, #9, #10,#12, #13 of a subframe overlapping with the aggressor ABS.
Note 8:	This noise is applied in OFDM symbols #0, #4, #7, #11 of a subframe overlapping with the aggressor ABS.
Note 9:	This noise is applied in all OFDM symbols of a subframe overlapping with aggressor non-ABS.
Note 10:	Downlink physical channel setup in Cell 2 and Cell 3 in accordance with Annex C.3.3 applying OCNG pattern as defined in Annex A.5.1.5
Note 11:	Reference measurement channel in Cell 1 RC.2 FDD according to Table A.4-1 with one sided dynamic OCNG Pattern OP.1 FDD as described in Annex A.5.1.1.
Note 12:	To avoid collisions between HARQ-ACK and wideband CQI it is necessary to report both on PUSCH instead of PUCCH. PDCCH DCI format 0 shall be transmitted in downlink SF#4 and #9 to allow periodic CQI to multiplex with the HARQ-ACK on PUSCH in uplink subframe SF#8 and #3.
Note 13:	<i>cqi-pmi-ConfigurationIndex</i> is applied for $C_{CSI,0}$.
Note 14:	<i>cqi-pmi-ConfigurationIndex2</i> is applied for $C_{CSI,1}$.

9.2.1.6 TDD (CSI measurements in case two CSI subframe sets are configured and with CRS assistance information)

The following requirements apply to UE Category ≥ 2 . For the parameters specified in Table 9.2.1.6-1, and using the downlink physical channels specified in tables C.3.2-1 for Cell 1, C3.3-2 for Cell 2 and Cell 3, and C.3.2-2, the reported CQI value according to RC.2 TDD in Table A.4-1 in subframes overlapping with aggressor cell ABS and non-ABS subframes shall be in the range of ± 1 of the reported median more than 90% of the time.

For test 1 and test 2, if the PDSCH BLER in ABS subframes using the transport format indicated by median CQI obtained by reports in CSI subframe sets $C_{CSI,0}$ is less than or equal to 0.1, the BLER in ABS subframes using the transport format indicated by the (median CQI + 1) shall be greater than 0.1. If the PDSCH BLER in ABS subframes using the transport format indicated by the median CQI is greater than 0.1, the BLER in ABS subframes using transport format indicated by (median CQI – 1) shall be less than or equal to 0.1.

For test 2, if the PDSCH BLER in non-ABS subframes using the transport format indicated by median CQI obtained by reports in CSI subframe sets $C_{CSI,1}$ is less than or equal to 0.1, the BLER in non-ABS subframes using the transport format indicated by the (median CQI + 2) shall be greater than 0.1. If the PDSCH BLER in non-ABS subframes using the transport format indicated by the median CQI is greater than 0.1, the BLER in non-ABS subframes using transport format indicated by (median CQI – 1) shall be less than or equal to 0.1.

Table 9.2.1.6-1: PUCCH 1-0 static test (TDD)

Parameter	Unit	Test 1			Test 2		
		Cell 1	Cell 2 and 3		Cell 1	Cell 2 and 3	
Bandwidth	MHz	10			10		
PDSCH transmission mode		2	Note 10		2	Note 10	
Uplink downlink configuration		1			1		
Special subframe configuration		4			4		
Downlink power allocation	ρ_A	dB			-3		
	ρ_B	dB			-3		
	σ	dB			0		
Propagation condition and antenna configuration		Clause B.1 (2x2)			Clause B.1 (2x2)		
\hat{E}_s / N_{oc2} (Note 1)	dB	4	5	Cell 2: 12 Cell 3: 10	13	14	Cell 2: 12 Cell 3: 10
$N_{oc}^{(j)}$ at antenna port	$N_{oc1}^{(j)}$	dBm/15kHz		-98 (Note 7)	N/A		-98 (Note 7)
	$N_{oc2}^{(j)}$	dBm/15kHz		-98 (Note 8)	N/A		-98 (Note 8)
	$N_{oc3}^{(j)}$	dBm/15kHz		-93 (Note 9)	N/A		-93 (Note 9)
Subframe Configuration		Non-MBSFN		Non-MBSFN	Non-MBSFN		Non-MBSFN
Cell Id		0		Cell 2: 6 Cell 3: 1	0		Cell 2: 6 Cell 3: 1
Time Offset between Cells	μ s	Cell 2: 3 usec Cell 3: -1usec			Cell 2: 3 usec Cell 3: -1usec		
Frequency shift between Cells	Hz	Cell 2: 300Hz Cell 3: -100Hz			Cell 2: 300Hz Cell 3: -100Hz		
ABS pattern (Note 2)		N/A		0100010001 0100010001	N/A		0100010001 0100010001
RLM/RRM Measurement Subframe Pattern (Note 4)		0000000001 0000000001		N/A		0000000001 0000000001	
CSI Subframe Sets (Note 3)	$C_{CSI,0}$	0100010001 0100010001		N/A		0100010001 0100010001	
	$C_{CSI,1}$	1000101000 1000101000		N/A		1000101000 1000101000	
Number of control OFDM symbols		3			3		
Max number of HARQ transmissions		1			1		
Physical channel for $C_{CSI,0}$ CQI reporting		PUCCH Format 2			PUCCH Format 2		
Physical channel for $C_{CSI,1}$ CQI reporting		PUSCH (Note 12)			PUSCH (Note 12)		
PUCCH Report Type		4			4		
Reporting periodicity	ms	$N_{pd} = 5$			$N_{pd} = 5$		
$cqi-pmi-ConfigurationIndex_{C_{CSI,0}}$ (Note 13)		3	N/A		3	N/A	
$cqi-pmi-ConfigurationIndex2_{C_{CSI,1}}$ (Note 14)		4	N/A		4	N/A	
ACK/NACK feedback mode		Multiplexing			Multiplexing		

Note 1:	For each test, the minimum requirements shall be fulfilled for at least one of the two SNR(s) and the respective wanted signal input level.
Note 2:	ABS pattern as defined in [9].
Note 3:	Time-domain measurement resource restriction pattern for PCell measurements as defined in [7]
Note 4:	As configured according to the time-domain measurement resource restriction pattern for CSI measurements defined in [7].
Note 5:	Time-domain measurement resource restriction pattern for PCell measurements as defined in [7]
Note 6:	Cell 1 is the serving cell. Cell 2 and Cell 3 are the aggressor cells. The number of the CRS ports in Cell1, Cell2, and Cell3 is the same.
Note 7:	This noise is applied in OFDM symbols #1, #2, #3, #5, #6, #8, #9, #10,#12, #13 of a subframe overlapping with the aggressor ABS.
Note 8:	This noise is applied in OFDM symbols #0, #4, #7, #11 of a subframe overlapping with the aggressor ABS
Note 9:	This noise is applied in all OFDM symbols of a subframe overlapping with aggressor non-ABS.
Note 10:	Downlink physical channel setup in Cell 2 and Cell 3 in accordance with Annex C.3.3 applying OCNG pattern as defined in Annex A.5.2.5
Note 11:	Reference measurement channel in Cell 1 RC.2 TDD according to Table A.4-1 with one sided dynamic OCNG Pattern OP.1 TDD as described in Annex A.5.2.1.
Note 12:	To avoid collisions between HARQ-ACK and wideband CQI it is necessary to report both on PUSCH instead of PUCCH. PDCCH DCI format 0 shall be transmitted in downlink SF#4 and #9 to allow periodic CQI to multiplex with the HARQ-ACK on PUSCH in uplink subframe SF#8 and #3.
Note 13:	<i>cqi-pmi-ConfigurationIndex</i> is applied for $C_{CSI,0}$.
Note 14:	<i>cqi-pmi-ConfigurationIndex2</i> is applied for $C_{CSI,1}$.

9.2.1.7 FDD (Modulation and TBS index Table 2 and 4-bit CQI Table 2 are used)

The following requirements apply to UE Category 11-12 and DL Category ≥ 11 . For the parameters specified in Table 9.2.1.7-1, and using the downlink physical channels specified in tables C.3.2-1 and C.3.2-2, the reported CQI value according to RC.1A FDD in Table A.4-1 shall be in the range of ± 1 of the reported median more than 90% of the time. If the PDSCH BLER using the transport format indicated by median CQI is less than or equal to 0.1, the BLER using the transport format indicated by the (median CQI + 1) shall be greater than 0.1, or the BLER using the transport format indicated by the (median CQI + 1) shall be less than or equal to 0.1 when the highest MCS value of the test case has reached. If the PDSCH BLER using the transport format indicated by the median CQI is greater than 0.1, the BLER using transport format indicated by (median CQI – 1) shall be less than or equal to 0.1.

In this test, 4-bit CQI Table 2 in Table 7.2.3-2 in TS 36.213 [6], and Modulation and TBS index table 2 in Table 7.1.7.1-1A for PDSCH in TS 36.213 [6] are applied.

Table 9.2.1.7-1: PUCCH 1-0 static test (FDD)

Parameter	Unit	Test 1		Test 2	
Bandwidth	MHz	10			
PDSCH transmission mode		1			
Downlink power allocation	ρ_A	dB		0	
	ρ_B	dB		0	
	σ	dB		0	
Propagation condition and antenna configuration		AWGN (1 x 2)			
SNR (Note 2)	dB	-1	0	20	21
$\hat{I}_{or}^{(j)}$	dB[mW/15kHz]	-99	-98	-78	-77
$N_{oc}^{(j)}$	dB[mW/15kHz]	-98		-98	
Max number of HARQ transmissions		1			
Physical channel for CQI reporting		PUCCH Format 2			
PUCCH Report Type		4			
Reporting periodicity	ms	$N_{pd} = 5$			
<i>cqi-pmi-ConfigurationIndex</i>		6			
Note 1:	Reference measurement channel RC.1A FDD according to Table A.4-1 with one sided dynamic OCNG Pattern OP.1 FDD as described in Annex A.5.1.1.				
Note 2:	For each test, the minimum requirements shall be fulfilled for at least one of the two SNR(s) and the respective wanted signal input level.				

9.2.1.8 TDD (Modulation and TBS index Table 2 and 4-bit CQI Table 2 are used)

The following requirements apply to UE Category 11-12 and UE DL Category ≥ 11 . For the parameters specified in Table 9.2.1.8-1, and using the downlink physical channels specified in tables C.3.2-1 and C.3.2-2, the reported CQI value according to RC.1A TDD in Table A.4-1 shall be in the range of ± 1 of the reported median more than 90% of the time. If the PDSCH BLER using the transport format indicated by median CQI is less than or equal to 0.1, the BLER using the transport format indicated by the (median CQI + 1) shall be greater than 0.1, or the BLER using the transport format indicated by the (median CQI + 1) shall be less than or equal to 0.1 when the highest MCS value of the test case has reached. If the PDSCH BLER using the transport format indicated by the median CQI is greater than 0.1, the BLER using transport format indicated by (median CQI – 1) shall be less than or equal to 0.1.

In this test, 4-bit CQI Table 2 in Table 7.2.3-2 in TS 36.213 [6], and Modulation and TBS index table 2 in Table 7.1.7.1-1A for PDSCH in TS 36.213 [6] are applied.

Table 9.2.1.8-1: PUCCH 1-0 static test (TDD)

Parameter		Unit	Test 1		Test 2	
Bandwidth		MHz	20			
PDSCH transmission mode			1			
Uplink downlink configuration			2			
Special subframe configuration			4			
Downlink power allocation	ρ_A	dB	0			
	ρ_B	dB	0			
	σ	dB	0			
Propagation condition and antenna configuration			AWGN (1 x 2)			
SNR (Note 2)		dB	-1	0	20	21
$\hat{I}_{or}^{(j)}$		dB[mW/15kHz]	-99	-98	-78	-77
$N_{oc}^{(j)}$		dB[mW/15kHz]	-98		-98	
Max number of HARQ transmissions			1			
Physical channel for CQI reporting			PUSCH (Note 3)			
PUCCH Report Type			4			
Reporting periodicity		ms	$N_{pd} = 5$			
<i>cqi-pmi-ConfigurationIndex</i>			3			
ACK/NACK feedback mode			Multiplexing			
Note 1: Reference measurement channel RC.1A TDD according to Table A.4-1 with one sided dynamic OCNG Pattern OP.1 TDD as described in Annex A.5.2.1. Note 2: For each test, the minimum requirements shall be fulfilled for at least one of the two SNR(s) and the respective wanted signal input level. Note 3: To avoid collisions between CQI reports and HARQ-ACK it is necessary to report both on PUSCH instead of PUCCH. PDCCH DCI format 0 shall be transmitted in downlink SF#3 and #8 to allow periodic CQI to multiplex with the HARQ-ACK on PUSCH in uplink subframe SF#7 and #2.						

9.2.2 Minimum requirement PUCCH 1-1 (Cell-Specific Reference Symbols)

The minimum requirements for dual codeword transmission are defined in terms of a reporting spread of the wideband CQI value for codeword #1, and their BLER performance using the transport format indicated by the reported CQI median of codeword #0 and codeword #1. The precoding used at the transmitter is a fixed precoding matrix specified by the bitmap parameter *codebookSubsetRestriction*. The propagation condition assumed for the minimum performance requirement is defined in subclause B.1.

9.2.2.1 FDD

The following requirements apply to UE Category ≥ 2 . For the parameters specified in table 9.2.2.1-1, and using the downlink physical channels specified in tables C.3.2-1 and C.3.2-2, the reported offset level of the wideband spatial

differential CQI for codeword #1 (Table 7.2-2 in TS 36.213 [6]) shall be used to determine the wideband CQI index for codeword #1 as

$$\text{wideband CQI}_1 = \text{wideband CQI}_0 - \text{Codeword 1 offset level}$$

The wideband CQI₁ shall be within the set {median CQI₁ -1, median CQI₁, median CQI₁ +1} for more than 90% of the time, where the resulting wideband values CQI₁ shall be used to determine the median CQI values for codeword #1. For both codewords #0 and #1, the PDSCH BLER using the transport format indicated by the respective median CQI₀ - 1 and median CQI₁ - 1 shall be less than or equal to 0.1. Furthermore, for both codewords #0 and #1, the PDSCH BLER using the transport format indicated by the respective median CQI₀ + 1 and median CQI₁ + 1 shall be greater than or equal to 0.1.

Table 9.2.2.1-1: PUCCH 1-1 static test (FDD)

Parameter	Unit	Test 1		Test 2	
Bandwidth	MHz	10			
PDSCH transmission mode		4			
Downlink power allocation	ρ_A	dB		-3	
	ρ_B	dB		-3	
	σ	dB		0	
Propagation condition and antenna configuration		Clause B.1 (2 x 2)			
CodeBookSubsetRestriction bitmap		010000			
SNR (Note 2)	dB	10	11	16	17
$\hat{I}_{or}^{(j)}$	dB[mW/15kHz]	-88	-87	-82	-81
$N_{oc}^{(j)}$	dB[mW/15kHz]	-98		-98	
Max number of HARQ transmissions		1			
Physical channel for CQI/PMI reporting		PUCCH Format 2			
PUCCH Report Type for CQI/PMI		2			
PUCCH Report Type for RI		3			
Reporting periodicity	ms	$N_{pd} = 5$			
<i>cqi-pmi-ConfigurationIndex</i>		6			
<i>ri-ConfigIndex</i>		1 (Note 3)			
Note 1:	Reference measurement channel RC.2 FDD according to Table A.4-1 with one sided dynamic OCNG Pattern OP.1 FDD as described in Annex A.5.1.1.				
Note 2:	For each test, the minimum requirements shall be fulfilled for at least one of the two SNR(s) and the respective wanted signal input level.				
Note 3:	It is intended to have UL collisions between RI reports and HARQ-ACK, since the RI reports shall not be used by the eNB in this test.				

9.2.2.2 TDD

The following requirements apply to UE Category ≥ 2 . For the parameters specified in table 9.2.2.2-1, and using the downlink physical channels specified in tables C.3.2-1 and C.3.2-2, the reported offset level of the wideband spatial differential CQI for codeword #1 (Table 7.2-2 in TS 36.213 [6]) shall be used to determine the wideband CQI index for codeword #1 as

$$\text{wideband CQI}_1 = \text{wideband CQI}_0 - \text{Codeword 1 offset level}$$

The wideband CQI₁ shall be within the set {median CQI₁ -1, median CQI₁, median CQI₁ +1} for more than 90% of the time, where the resulting wideband values CQI₁ shall be used to determine the median CQI values for codeword #1. For both codewords #0 and #1, the PDSCH BLER using the transport format indicated by the respective median CQI₀ - 1 and median CQI₁ - 1 shall be less than or equal to 0.1. Furthermore, for both codewords #0 and #1, the PDSCH BLER using the transport format indicated by the respective median CQI₀ + 1 and median CQI₁ + 1 shall be greater than or equal to 0.1.

Table 9.2.2.2-1: PUCCH 1-1 static test (TDD)

Parameter		Unit	Test 1		Test 2	
Bandwidth		MHz			10	
PDSCH transmission mode					4	
Uplink downlink configuration					2	
Special subframe configuration					4	
Downlink power allocation	ρ_A	dB			-3	
	ρ_B	dB			-3	
	σ	dB			0	
Propagation condition and antenna configuration			Clause B.1 (2 x 2)			
CodeBookSubsetRestriction bitmap			010000			
SNR (Note 2)		dB	10	11	16	17
$\hat{I}_{or}^{(j)}$		dB[mW/15kHz]	-88	-87	-82	-81
$N_{oc}^{(j)}$		dB[mW/15kHz]	-98		-98	
Max number of HARQ transmissions			1			
Physical channel for CQI/PMI reporting			PUSCH (Note 3)			
PUCCH Report Type			2			
Reporting periodicity		ms	$N_{pd} = 5$			
<i>cqi-pmi-ConfigurationIndex</i>			3			
<i>ri-ConfigIndex</i>			805 (Note 4)			
ACK/NACK feedback mode			Multiplexing			
Note 1:		Reference measurement channel RC.2 TDD according to Table A.4-1 with one sided dynamic OCNG Pattern OP.1 TDD as described in Annex A.5.2.1.				
Note 2:		For each test, the minimum requirements shall be fulfilled for at least one of the two SNR(s) and the respective wanted signal input level.				
Note 3:		To avoid collisions between CQI/PMI reports and HARQ-ACK it is necessary to report both on PUSCH instead of PUCCH. PDCCH DCI format 0 shall be transmitted in downlink SF#3 and #8 to allow periodic CQI/PMI to multiplex with the HARQ-ACK on PUSCH in uplink subframe SF#7 and #2.				
Note 4:		RI reporting interval is set to the maximum allowable length of 160ms to minimise collisions between RI, CQI/PMI and HARQ-ACK reports. In the case when all three reports collide, it is expected that CQI/PMI reports will be dropped, while RI and HARQ-ACK will be multiplexed. At eNB, CQI report collection shall be skipped every 160ms during performance verification.				

9.2.3 Minimum requirement PUCCH 1-1 (CSI Reference Symbols)

The minimum requirements for dual codeword transmission are defined in terms of a reporting spread of the wideband CQI value for codeword #1, and their BLER performance using the transport format indicated by the reported CQI median of codeword #0 and codeword #1. The precoding used at the transmitter is a fixed precoding matrix specified by the bitmap parameter *codebookSubsetRestriction*. The propagation condition assumed for the minimum performance requirement is defined in subclause B.1.

9.2.3.1 FDD

The following requirements apply to UE Category ≥ 2 . For the parameters specified in table 9.2.3.1-1, and using the downlink physical channels specified in tables C.3.2-1 and C.3.2-2, the reported offset level of the wideband spatial differential CQI for codeword #1 (Table 7.2-2 in TS 36.213 [6]) shall be used to determine the wideband CQI index for codeword #1 as

$$\text{wideband CQI}_1 = \text{wideband CQI}_0 - \text{Codeword 1 offset level}$$

The wideband CQI₁ shall be within the set {median CQI₁ - 1, median CQI₁, median CQI₁ + 1} for more than 90% of the time, where the resulting wideband values CQI₁ shall be used to determine the median CQI values for codeword #1. For both codewords #0 and #1, the PDSCH BLER using the transport format indicated by the respective median CQI₀ - 1 and median CQI₁ - 1 shall be less than or equal to 0.1. Furthermore, for both codewords #0 and #1, the PDSCH BLER

using the transport format indicated by the respective median $CQI_0 + 1$ and median $CQI_1 + 1$ shall be greater than or equal to 0.1.

Table 9.2.3.1-1: PUCCH 1-1 static test (FDD)

Parameter		Unit	Test 1		Test 2	
Bandwidth		MHz	10			
PDSCH transmission mode			9			
Downlink power allocation	ρ_A	dB	0			
	ρ_B	dB	0			
	P_c	dB	-3			
	σ	dB	-3			
Cell-specific reference signals			Antenna ports 0, 1			
CSI reference signals			Antenna ports 15,...,18			
CSI-RS periodicity and subframe offset $T_{CSI-RS} / \Delta_{CSI-RS}$			5/1			
CSI reference signal configuration			0			
Propagation condition and antenna configuration			Clause B.1 (4 x 2)			
Beamforming Model			As specified in Section B.4.3			
CodeBookSubsetRestriction bitmap			0x0000 0000 0100 0000			
SNR (Note 2)		dB	7	8	13	14
$\hat{I}_{or}^{(j)}$		dB[mW/15kHz]	-91	-90	-85	-84
$N_{oc}^{(j)}$		dB[mW/15kHz]	-98		-98	
Max number of HARQ transmissions			1			
Physical channel for CQI/PMI reporting			PUSCH (Note3)			
PUCCH Report Type for CQI/PMI			2			
Physical channel for RI reporting			PUCCH Format 2			
PUCCH Report Type for RI			3			
Reporting periodicity		ms	$N_{pd} = 5$			
CQI delay		ms	8			
<i>cqi-pmi-ConfigurationIndex</i>			2			
<i>ri-ConfigIndex</i>			1			
<p>Note 1: Reference measurement channel RC.7 FDD according to Table A.4-1 with one sided dynamic OCNG Pattern OP.1 FDD as described in Annex A.5.1.1.</p> <p>Note 2: For each test, the minimum requirements shall be fulfilled for at least one of the two SNR(s) and the respective wanted signal input level.</p> <p>Note 3: To avoid collisions between CQI/PMI reports and HARQ-ACK it is necessary to report both on PUSCH instead of PUCCH. PDCCH DCI format 0 shall be transmitted in downlink SF#1 and #6 to allow periodic CQI/PMI to multiplex with the HARQ-ACK on PUSCH in uplink SF#0 and #5.</p>						

9.2.3.2 TDD

The following requirements apply to UE Category ≥ 2 . For the parameters specified in table 9.2.3.2-1, and using the downlink physical channels specified in tables C.3.2-1 and C.3.2-2, the reported offset level of the wideband spatial differential CQI for codeword #1 (Table 7.2-2 in TS 36.213 [6]) shall be used to determine the wideband CQI index for codeword #1 as

$$\text{wideband } CQI_1 = \text{wideband } CQI_0 - \text{Codeword 1 offset level}$$

The wideband CQI_1 shall be within the set $\{\text{median } CQI_1 - 1, \text{median } CQI_1, \text{median } CQI_1 + 1\}$ for more than 90% of the time, where the resulting wideband values CQI_1 shall be used to determine the median CQI values for codeword #1. For both codewords #0 and #1, the PDSCH BLER using the transport format indicated by the respective median $CQI_0 - 1$ and median $CQI_1 - 1$ shall be less than or equal to 0.1. Furthermore, for both codewords #0 and #1, the PDSCH BLER using the transport format indicated by the respective median $CQI_0 + 1$ and median $CQI_1 + 1$ shall be greater than or equal to 0.1.

Table 9.2.3.2-1: PUCCH 1-1 submode 1 static test (TDD)

Parameter		Unit	Test 1		Test 2	
Bandwidth		MHz	10			
PDSCH transmission mode			9			
Uplink downlink configuration			2			
Special subframe configuration			4			
Downlink power allocation	ρ_A	dB	0			
	ρ_B	dB	0			
	P_c	dB	-6			
	σ	dB	-3			
CRS reference signals			Antenna ports 0, 1			
CSI reference signals			Antenna ports 15,...,22			
CSI-RS periodicity and subframe offset $T_{\text{CSI-RS}} / \Delta_{\text{CSI-RS}}$			5/3			
CSI reference signal configuration			0			
Propagation condition and antenna configuration			Clause B.1 (8 x 2)			
Beamforming Model			As specified in Section B.4.3			
CodeBookSubsetRestriction bitmap			0x0000 0000 0020 0000 0000 0001 0000			
SNR (Note 2)		dB	4	5	10	11
$\hat{I}_{or}^{(j)}$		dB[mW/15kHz]	-94	-93	-88	-87
$N_{oc}^{(j)}$		dB[mW/15kHz]	-98		-98	
Max number of HARQ transmissions			1			
Physical channel for CQI/PMI reporting			PUSCH (Note 3)			
PUCCH Report Type for CQI/second PMI			2b			
Physical channel for RI reporting			PUSCH			
PUCCH Report Type for RI/ first PMI			5			
Reporting periodicity		ms	$N_{pd} = 5$			
CQI delay		ms	10 or 11			
<i>cqi-pmi-ConfigurationIndex</i>			3			
<i>ri-ConfigIndex</i>			805 (Note 4)			
ACK/NACK feedback mode			Multiplexing			
Note 1: Reference measurement channel RC.7 TDD according to Table A.4-1 with one sided dynamic OCNG Pattern OP.1 TDD as described in Annex A.5.2.1.						
Note 2: For each test, the minimum requirements shall be fulfilled for at least one of the two SNR(s) and the respective wanted signal input level.						
Note 3: To avoid collisions between CQI/PMI reports and HARQ-ACK it is necessary to report both on PUSCH instead of PUCCH. PDCCH DCI format 0 shall be transmitted in downlink SF#3 and #8 to allow periodic CQI/PMI to multiplex with the HARQ-ACK on PUSCH in uplink SF#7 and #2.						
Note 4: RI reporting interval is set to the maximum allowable length of 160ms to minimise collisions between RI, CQI/PMI and HARQ-ACK reports. In the case when all three reports collide, it is expected that CQI/PMI reports will be dropped, while RI and HARQ-ACK will be multiplexed. At eNB, CQI report collection shall be skipped every 160ms during performance verification.						

9.2.4 Minimum requirement PUCCH 1-1 (With Single CSI Process)

The minimum requirements for dual codeword transmission are defined in terms of a reporting spread of the wideband CQI value for codeword #1, and their BLER performance using the transport format indicated by the reported CQI median of codeword #0 and codeword #1. The precoding used at the transmitter is a fixed precoding matrix specified by the bitmap parameter *codebookSubsetRestriction*. The propagation condition assumed for the minimum performance requirement is defined in subclause B.1.

9.2.4.1 FDD

The following requirements apply to UE Category ≥ 2 . For the parameters specified in table 9.2.4.1-1, and using the downlink physical channels specified in Tables C.3.4-1 and C.3.4-2, the reported offset level of the wideband spatial

differential CQI for codeword #1 (Table 7.2-2 in TS 36.213 [6]) shall be used to determine the wideband CQI index for codeword #1 as

$$\text{wideband CQI}_1 = \text{wideband CQI}_0 - \text{Codeword 1 offset level}$$

The wideband CQI₁ shall be within the set {median CQI₁ -1, median CQI₁, median CQI₁ +1} for more than 90% of the time, where the resulting wideband values CQI₁ shall be used to determine the median CQI values for codeword #1. For both codewords #0 and #1, the PDSCH BLER using the transport format indicated by the respective median CQI₀ - 1 and median CQI₁ - 1 shall be less than or equal to 0.1. Furthermore, for both codewords #0 and #1, the PDSCH BLER using the transport format indicated by the respective median CQI₀ + 1 and median CQI₁ + 1 shall be greater than or equal to 0.1.

Table 9.2.4.1-1: PUCCH 1-1 static test (FDD)

Parameter	Unit	Test 1			Test 2		
		TP1	TP2		TP1	TP2	
Bandwidth	MHz	10					
PDSCH transmission mode		10					
Downlink power allocation (Note 1)	ρ_A	dB	0	0	0	0	0
	ρ_B	dB	0	0	0	0	0
	P_c	dB	-3	-3	-3	-3	-3
	σ	dB	-3	N/A	-3	N/A	N/A
Cell ID		0			0		
Cell-specific reference signals		Antenna ports 0, 1	(Note 2)		Antenna ports 0, 1	(Note 2)	
CSI reference signals		Antenna ports 15, ..., 18	N/A		Antenna ports 15, ..., 18	N/A	
CSI-RS periodicity and subframe offset $T_{\text{CSI-RS}} / \Delta_{\text{CSI-RS}}$		5/1	N/A		5/1	N/A	
CSI-RS configuration		0	N/A		0	N/A	
Zero-Power CSI-RS configuration $l_{\text{CSI-RS}} / \text{ZeroPowerCSI-RS}$ bitmap		1 / 001000000000 0000	1 / 100000000000 00000		1 / 001000000000 0000	1 / 100000000000 00000	
CSI-IM configuration $l_{\text{CSI-RS}} / \text{ZeroPowerCSI-RS}$ bitmap		1 / 001000000000 0000	N/A		1 / 001000000000 0000	N/A	
CSI process configuration Signal/Interference/Reporting mode		CSI-RS/CSI-IM/PUCCH 1-1			CSI-RS/CSI-IM/PUCCH 1-1		
Propagation condition and antenna configuration		Clause B.1 (4 x 2)	Clause B.1 (2 x 2)		Clause B.1 (4 x 2)	Clause B.1 (2 x 2)	
CodeBookSubsetRestriction bitmap		0x0000 0000 0100 0000	100000		0x0000 0000 0100 0000	100000	
SNR (Note 3)	dB	20	6	7	20	14	15
$\hat{I}_{or}^{(j)}$	dB[mW/15kHz]	-78	-92	-91	-78	-84	-83
$N_{oc}^{(j)}$	dB[mW/15kHz]	-98			-98		
Modulation / Information bit payload		(Note4)	QPSK / 4392		(Note4)	QPSK / 4392	
Max number of HARQ transmissions		1	N/A		1	N/A	
Physical channel for CQI/PMI reporting		PUSCH (Note5)	N/A		PUSCH (Note5)	N/A	
PUCCH Report Type for CQI/PMI		2	N/A		2	N/A	
PUCCH Report Type for RI		3	N/A		3	N/A	
Reporting periodicity	ms	$N_{pd} = 5$	N/A		$N_{pd} = 5$	N/A	
CQI Delay	ms	8	N/A		8	N/A	
$cqi-pmi-ConfigurationIndex$		2	N/A		2	N/A	
$ri-ConfigIndex$		1	N/A		1	N/A	
PDSCH scheduled sub-frames		1,2,3,4,6,7,8,9			1,2,3,4,6,7,8,9		
Timing offset between TPs	us	0			0		
Frequency offset between TPs	Hz	0			0		
Note 1:	Reference measurement channel RC.10 FDD according to Table A.4-1 with one sided dynamic OCNG Pattern OP.1 FDD as described in Annex A.5.1.1.						
Note 2:	REs for antenna ports 0 and 1 CRS have zero transmission power.						
Note 3:	For each test, the minimum requirements shall be fulfilled for at least one of the two SNR(s) and the respective wanted signal input level.						
Note 4:	N/A.						
Note 5:	To avoid collisions between CQI/PMI reports and HARQ-ACK it is necessary to report both on PUSCH instead of PUCCH. PDCCH DCI format 0 shall be transmitted in downlink SF#1 and #6 to allow periodic CQI/PMI to multiplex with the HARQ-ACK on PUSCH in uplink SF#0 and #5.						

9.2.4.2 TDD

The following requirements apply to UE Category ≥ 2 . For the parameters specified in table 9.2.4.2-1, and using the downlink physical channels specified in Tables C.3.4-1 and C.3.4-2, the reported offset level of the wideband spatial differential CQI for codeword #1 (Table 7.2-2 in TS 36.213 [6]) shall be used to determine the wideband CQI index for codeword #1 as

$$\text{wideband CQI}_1 = \text{wideband CQI}_0 - \text{Codeword 1 offset level}$$

The wideband CQI_1 shall be within the set $\{\text{median CQI}_1 - 1, \text{median CQI}_1, \text{median CQI}_1 + 1\}$ for more than 90% of the time, where the resulting wideband values CQI_1 shall be used to determine the median CQI values for codeword #1. For both codewords #0 and #1, the PDSCH BLER using the transport format indicated by the respective median $\text{CQI}_0 - 1$ and median $\text{CQI}_1 - 1$ shall be less than or equal to 0.1. Furthermore, for both codewords #0 and #1, the PDSCH BLER using the transport format indicated by the respective median $\text{CQI}_0 + 1$ and median $\text{CQI}_1 + 1$ shall be greater than or equal to 0.1.

Table 9.2.4.2-1: PUCCH 1-1 static test (TDD)

Parameter		Unit	Test 1			Test 2		
			TP1	TP2		TP1	TP2	
Bandwidth		MHz	10					
PDSCH transmission mode			10					
Uplink downlink configuration			2					
Special subframe configuration			4					
Downlink power allocation (Note 1)	ρ_A	dB	0	0	0	0	0	
	ρ_B	dB	0	0	0	0	0	
	P_c	dB	-6	-6	-6	-6	-6	
	σ	dB	-3	N/A	-3	N/A	N/A	
Cell ID			0			0		
Cell-specific reference signals			Antenna ports 0, 1	(Note 2)	Antenna ports 0, 1	(Note 2)		
CSI reference signals			Antenna ports 15, ..., 22	N/A	Antenna ports 15, ..., 22	N/A		
CSI-RS periodicity and subframe offset $T_{CSI-RS} / \Delta_{CSI-RS}$			5/3	N/A	5/3	N/A		
CSI-RS configuration			0	N/A	0	N/A		
Zero-Power CSI-RS configuration $l_{CSI-RS} / ZeroPowerCSI-RS$ bitmap			3 / 001000000000 0000	3 / 10000100000 00000	3 / 001000000000 0000	3 / 10000100000 00000		
CSI-IM configuration $l_{CSI-RS} / ZeroPowerCSI-RS$ bitmap			3 / 001000000000 0000	N/A	3 / 001000000000 0000	N/A		
CSI process configuration Signal/Interference/Reporting mode			CSI-RS/CSI-IM/PUCCH 1-1			CSI-RS/CSI-IM/PUCCH 1-1		
Propagation condition and antenna configuration			Clause B.1 (8 x 2)	Clause B.1 (2 x 2)	Clause B.1 (8 x 2)	Clause B.1 (2 x 2)		
CodeBookSubsetRestriction bitmap			0x0000 0000 0020 0000 0000 0001 0000	100000	0x0000 0000 0020 0000 0000 0001 0000	100000		
SNR (Note 3)		dB	17	6	7	17	14	15
$\hat{I}_{or}^{(j)}$		dB[mW/15kHz]	-81	-92	-91	-81	-84	-83
$N_{oc}^{(j)}$		dB[mW/15kHz]	-98			-98		
Modulation / Information bit payload			(Note4)	QPSK / 4392		(Note4)	QPSK / 4392	
Max number of HARQ transmissions			1	N/A		1	N/A	
Physical channel for CQI/PMI reporting			PUSCH (Note5)	N/A		PUSCH (Note5)	N/A	
PUCCH Report Type for CQI/second PMI			2b	N/A		2b	N/A	
Physical channel for RI reporting			PUSCH	N/A		PUSCH	N/A	
PUCCH Report Type for RI/ first PMI			5	N/A		5	N/A	
Reporting periodicity		ms	$N_{pd} = 5$		N/A	$N_{pd} = 5$		N/A
CQI Delay		ms	10 or 11		N/A	10 or 11		N/A
<i>cqi-pmi-ConfigurationIndex</i>			3		N/A	3		N/A
<i>ri-ConfigIndex</i>			805 (Note 6)		N/A	805 (Note 6)		N/A
ACK/NACK feedback mode			Multiplexing		N/A	Multiplexing		N/A
PDSCH scheduled sub-frames			3,4,8,9			3,4,8,9		
Timing offset between TPs		us	0			0		
Frequency offset between TPs		Hz	0			0		

Note 1:	Reference measurement channel RC.10 TDD according to Table A.4-1 with one sided dynamic OCNG Pattern OP.1 TDD as described in Annex A.5.2.1.
Note 2:	REs for antenna ports 0 and 1 CRS have zero transmission power.
Note 3:	For each test, the minimum requirements shall be fulfilled for at least one of the two SNR(s) and the respective wanted signal input level.
Note 4:	N/A.
Note 5:	To avoid collisions between CQI/PMI reports and HARQ-ACK it is necessary to report both on PUSCH instead of PUCCH. PDCCH DCI format 0 shall be transmitted in downlink SF#3 and #8 to allow periodic CQI/PMI to multiplex with the HARQ-ACK on PUSCH in uplink SF#7 and #2.
Note 6:	RI reporting interval is set to the maximum allowable length of 160ms to minimise collisions between RI, CQI/PMI and HARQ-ACK reports. In the case when all three reports collide, it is expected that CQI/PMI reports will be dropped, while RI and HARQ-ACK will be multiplexed. At eNB, CQI report collection shall be skipped every 160ms during performance verification.

9.2.5 Minimum requirement PUCCH 1-1 (when *csi-SubframeSet-r12* and *EIMTA-MainConfigServCell-r12* are configured)

The following requirements apply to UE Category ≥ 2 which supports eIMTA TDD UL-DL reconfiguration for TDD serving cell(s) via monitoring PDCCH with eIMTA-RNTI and Rel-12 CSI subframe sets. For the parameters specified in table 9.2.5-1, and using the downlink physical channels specified in Tables C.3.2-1 and C.3.2-2, for each CSI subframe set, the reported CQI value shall be in the range of ± 1 of the reported median more than 90% of the time. For each CSI subframe set, if the PDSCH BLER using the transport format indicated by median CQI is less than or equal to 0.1, the BLER using the transport format indicated by the (median CQI + 1) shall be greater than 0.1. If the PDSCH BLER using the transport format indicated by the median CQI is greater than 0.1, the BLER using transport format indicated by (median CQI - 1) shall be less than or equal to 0.1. The difference of the median CQI obtained by reports in CSI subframe sets $C_{CSI,0}$ and the median CQI obtained by reports in CSI subframe sets $C_{CSI,1}$ shall be larger than or equal to 3.

Table 9.2.5 -1: PUCCH 1-1 static test (TDD)

Parameter	Unit	Test	
Bandwidth	MHz	10	
PDSCH transmission mode		9	
Uplink downlink configuration in SIB1		0	
Downlink HARQ reference configuration (eimta-HarqReferenceConfig-r12) (Note 4)		2	
Set of dynamic TDD UL-DL configurations (Notes 4,5)		{0, 2}	
Periodicity of monitoring the L1 reconfiguration DCI (eimta-CommandPeriodicity-r12)	ms	10	
Set of subframes to monitor the L1 reconfiguration DCI (eimta-CommandSubframeSet-r12)		SF#5	
CSI-MeasSubframeSet-r12		0001100011	
Special subframe configuration		4	
Downlink power allocation	ρ_A	dB	0
	ρ_B	dB	0
	P_c	dB	0
	σ	dB	-3
CRS reference signals		Antenna ports 0, 1	
CSI reference signals		Antenna ports 15,16	
CSI-RS periodicity and subframe offset $T_{\text{CSI-RS}} / \Delta_{\text{CSI-RS}}$		5/4	
CSI reference signal configuration		4	
Zero-Power CSI-RS configuration 0 $I_{\text{CSI-RS}} / \text{ZeroPowerCSI-RS}$ bitmap		0 / 0000010000000000	
Zero-Power CSI-RS configuration 1 $I_{\text{CSI-RS}} / \text{ZeroPowerCSI-RS}$ bitmap		4 / 0100000000000000	
Propagation condition and antenna configuration		Clause B.1 (2 x 2)	
Beamforming Model		As specified in Section B.4.3	
CodeBookSubsetRestriction bitmap		'000001'	
SNR in CSI subframe set 0	dB	0	1
SNR in CSI subframe set 1	dB	10	11
$\hat{I}_{or}^{(j)}$	dB[mW/15kHz]	-98	-97
$N_{oc1}^{(j)}$ for CSI subframe set 0	dB[mW/15kHz]	-98	-98
$N_{oc2}^{(j)}$ for CSI subframe set 1	dB[mW/15kHz]	-108	-108
PDSCH scheduled subframes for CSI subframe set 0		0,5	
PDSCH scheduled subframes for CSI subframe set 1		3,4,8,9	
Max number of HARQ transmissions		1	
Physical channel for CQI/PMI reporting		PUSCH (Note 6)	
PUCCH Report Type for CQI/second PMI		2b	
Physical channel for RI reporting		PUSCH	
PUCCH Report Type for RI/ first PMI		5	
Reporting periodicity	ms	$N_{pd} = 10$ for each Rel-12 CSI subframe set	
CQI delay	ms	14 for CSI subframe set 0 12 for CSI subframe set 1	
<i>cqi-pmi-ConfigurationIndex</i>		8 for set 0 13 for set 1	
<i>ri-ConfigIndex</i>		805 for both set 0 and set 1 (Note 7)	
ACK/NACK feedback mode		Multiplexing	

Note 1:	Reference measurement channel RC.19 TDD according to Table A.4-1 with one sided dynamic OCNG Pattern OP.1 TDD and dynamic OCNG Pattern with multiple non-contiguous blocks OP.7 TDD as described in Annex A.5.2.1/7 for CSI subframe set 0.
Note 2:	Reference measurement channel RC.20 TDD according to Table A.4-1 with one sided dynamic OCNG Pattern OP.1 TDD as described in Annex A.5.2.1 for CSI subframe set 1.
Note 3:	In the test, the minimum requirements shall be fulfilled for at least one of the two SNR(s) and the respective wanted signal input level for each CSI subframe set separately.
Note 4:	As specified in Table 4.2-2 in TS 36.211.
Note 5:	UL/DL configuration in PDCCH with eIMTA-RNTI is cyclically selected from the given set on a per-DCI basis.
Note 6:	To avoid collisions between CQI/PMI reports and HARQ-ACK it is necessary to report both on PUSCH instead of PUCCH. PDCCH DCI format 0 shall be transmitted in downlink SF#1 and #6 to allow periodic CQI/PMI to multiplex with the HARQ-ACK on PUSCH in uplink SF#7 and #2. CQI/PMI reports for CSI subframe set 0 is transmitted in SF#2 and CQI/PMI reports for CSI subframe set 1 is transmitted in SF#7.
Note 7:	RI reporting interval is set to the maximum allowable length of 160ms to minimise collisions between RI, CQI/PMI and HARQ-ACK reports. In the case when all three reports collide, it is expected that CQI/PMI reports will be dropped, while RI and HARQ-ACK will be multiplexed. At eNB, CQI report collection shall be skipped every 160ms during performance verification.

9.3 CQI reporting under fading conditions

9.3.1 Frequency-selective scheduling mode

The accuracy of sub-band channel quality indicator (CQI) reporting under frequency selective fading conditions is determined by a double-sided percentile of the reported differential CQI offset level 0 per sub-band, and the relative increase of the throughput obtained when transmitting on a randomly selected sub-band among the sub-bands with the highest reported differential CQI offset level the corresponding transport format compared to the case for which a fixed format is transmitted on any sub-band in set S of TS 36.213 [6]. The purpose is to verify that preferred sub-bands can be used for frequently-selective scheduling. To account for sensitivity of the input SNR the sub-band CQI reporting under frequency selective fading conditions is considered to be verified if the reporting accuracy is met for at least one of two SNR levels separated by an offset of 1 dB.

9.3.1.1 Minimum requirement PUSCH 3-0 (Cell-Specific Reference Symbols)

9.3.1.1.1 FDD

For the parameters specified in Table 9.3.1.1.1-1, and using the downlink physical channels specified in Annex C.3.2, the minimum requirements are specified in Table 9.3.1.1.1-2 and by the following

- a sub-band differential CQI offset level of 0 shall be reported at least $\alpha\%$ of the time but less than $\beta\%$ for each sub-band;
- the ratio of the throughput obtained when transmitting on a randomly selected sub-band among the sub-bands with the highest differential CQI offset level the corresponding TBS and that obtained when transmitting the TBS indicated by the reported wideband CQI median on a randomly selected sub-band in set S shall be $\geq \gamma$;
- when transmitting on a randomly selected sub-band among the sub-bands with the highest differential CQI offset level the corresponding TBS, the average BLER for the indicated transport formats shall be greater or equal to 0.05.

The requirements only apply for sub-bands of full size and the random scheduling across the sub-bands is done by selecting a new sub-band in each TTI for FDD, each available downlink transmission instance for TDD.

Table 9.3.1.1.1-1 Sub-band test for single antenna transmission (FDD)

Parameter		Unit	Test 1		Test 2	
Bandwidth		MHz	10 MHz			
Transmission mode			1 (port 0)			
Downlink power allocation	ρ_A	dB	0			
	ρ_B	dB	0			
	σ	dB	0			
SNR (Note 3)		dB	9	10	14	15
$\hat{I}_{or}^{(j)}$		dB[mW/15kHz]	-89	-88	-84	-83
$N_{oc}^{(j)}$		dB[mW/15kHz]	-98		-98	
Propagation channel			Clause B.2.4 with $\tau_d = 0.45 \mu s$, $a = 1$, $f_D = 5$ Hz			
Antenna configuration			1 x 2			
Reporting interval		ms	5			
CQI delay		ms	8			
Reporting mode			PUSCH 3-0			
Sub-band size		RB	6 (full size)			
Max number of HARQ transmissions			1			
<p>Note 1: If the UE reports in an available uplink reporting instance at subframe SF#n based on CQI estimation at a downlink subframe not later than SF#(n-4), this reported subband or wideband CQI cannot be applied at the eNB downlink before SF#(n+4)</p> <p>Note 2: Reference measurement channel RC.3 FDD according to Table A.4-1 with one/two sided dynamic OCNG Pattern OP.1/2 FDD as described in Annex A.5.1.1/2.</p> <p>Note 3: For each test, the minimum requirements shall be fulfilled for at least one of the two SNR(s) and the respective wanted signal input level.</p>						

Table 9.3.1.1.1-2 Minimum requirement (FDD)

	Test 1	Test 2
α [%]	2	2
β [%]	55	55
γ	1.1	1.1
UE Category	≥ 1	≥ 1

9.3.1.1.2 TDD

For the parameters specified in Table 9.3.1.1.2-1, and using the downlink physical channels specified in Annex C.3.2, the minimum requirements are specified in Table 9.3.1.1.2-2 and by the following

- a sub-band differential CQI offset level of 0 shall be reported at least α % of the time but less than β % for each sub-band;
- the ratio of the throughput obtained when transmitting on a randomly selected sub-band among the sub-bands with the highest differential CQI offset level the corresponding TBS and that obtained when transmitting the TBS indicated by the reported wideband CQI median on a randomly selected sub-band in set S shall be $\geq \gamma$;
- when transmitting on a randomly selected sub-band among the sub-bands with the highest differential CQI offset level the corresponding TBS, the average BLER for the indicated transport formats shall be greater or equal to 0.05.

The requirements only apply for sub-bands of full size and the random scheduling across the sub-bands is done by selecting a new sub-band in each TTI for FDD, each available downlink transmission instance for TDD.

Table 9.3.1.1.2-1 Sub-band test for single antenna transmission (TDD)

Parameter		Unit	Test 1		Test 2	
Bandwidth		MHz	10 MHz			
Transmission mode			1 (port 0)			
Downlink power allocation	ρ_A	dB	0			
	ρ_B	dB	0			
	σ	dB	0			
Uplink downlink configuration			2			
Special subframe configuration			4			
SNR (Note 3)		dB	9	10	14	15
$\hat{I}_{or}^{(j)}$		dB[mW/15kHz]	-89	-88	-84	-83
$N_{oc}^{(j)}$		dB[mW/15kHz]	-98		-98	
Propagation channel			Clause B.2.4 with $\tau_d = 0.45 \mu\text{s}$, $a = 1$, $f_D = 5 \text{ Hz}$			
Antenna configuration			1 x 2			
Reporting interval		ms	5			
CQI delay		ms	10 or 11			
Reporting mode			PUSCH 3-0			
Sub-band size		RB	6 (full size)			
Max number of HARQ transmissions			1			
ACK/NACK feedback mode			Multiplexing			
<p>Note 1: If the UE reports in an available uplink reporting instance at subframe SF#n based on CQI estimation at a downlink subframe not later than SF#(n-4), this reported subband or wideband CQI cannot be applied at the eNB downlink before SF#(n+4)</p> <p>Note 2: Reference measurement channel RC.3 TDD according to Table A.4-1 with one/two sided dynamic OCNG Pattern OP.1/2 TDD as described in Annex A.5.2.1/2.</p> <p>Note 3: For each test, the minimum requirements shall be fulfilled for at least one of the two SNR(s) and the respective wanted signal input level.</p>						

Table 9.3.1.1.2-2 Minimum requirement (TDD)

	Test 1	Test 2
α [%]	2	2
β [%]	55	55
γ	1.1	1.1
UE Category	≥ 1	≥ 1

9.3.1.1.3 FDD (CSI measurements in case two CSI subframe sets are configured and with CRS assistance information)

For the parameters specified in Table 9.3.1.1.3-1, and using the downlink physical channels specified in Annex C.3.2, the minimum requirements are specified in Table 9.3.1.1.3-2 and by the following

- a sub-band differential CQI offset level of 0 shall be reported at least α % of the time but less than β % for each sub-band;
- the ratio of the throughput in ABS subframes obtained when transmitting on a randomly selected sub-band among the sub-bands with the highest differential CQI offset level the corresponding TBS and that obtained when transmitting the TBS indicated by the reported wideband CQI median on a randomly selected sub-band in set S shall be $\geq \gamma$;

- c) when transmitting on a randomly selected sub-band among the sub-bands with the highest differential CQI offset level the corresponding TBS, the average BLER in ABS subframes for the indicated transport formats shall be greater than or equal to ϵ .

The requirements only apply for sub-bands of full size and the random scheduling across the sub-bands is done by selecting a new sub-band in each TTI for FDD, each available downlink transmission instance for TDD.

Table 9.3.1.1.3-1 Sub-band test for single antenna transmission (FDD)

Parameter		Unit	Test 1			Test 2		
			Cell 1		Cell 2 and 3	Cell 1		Cell 2 and 3
Bandwidth		MHz	10			10		
PDSCH transmission mode			1		Note 10	1		Note 10
Downlink power allocation	ρ_A	dB	0			0		
	ρ_B	dB	0			0		
	σ	dB	0			0		
Propagation condition			Clause B.2.4 with Td = 0.45 us, a = 1, fd = 5 Hz		EVA5 Low antenna correlation	Clause B.2.4 with Td = 0.45 us, a = 1, fd = 5 Hz		EVA5 Low antenna correlation
Antenna configuration			1x2			1x2		
\widehat{E}_s / N_{oc2} (Note 1)		dB	4	5	Cell 2: 12 Cell 3: 10	14	15	Cell 2: 12 Cell 3: 10
$N_{oc}^{(j)}$ at antenna port	$N_{oc1}^{(j)}$	dBm/15kHz	-98 (Note 7)		N/A	-98 (Note 7)		N/A
	$N_{oc2}^{(j)}$	dBm/15kHz	-98 (Note 8)		N/A	-98 (Note 8)		N/A
	$N_{oc3}^{(j)}$	dBm/15kHz	-93 (Note 9)		N/A	-93 (Note 9)		N/A
Subframe Configuration			Non-MBSFN		Non-MBSFN	Non-MBSFN		Non-MBSFN
Cell Id			0		Cell 2: 6 Cell 3: 1	0		Cell 2: 6 Cell 3: 1
Time Offset between Cells		μ s	Cell 2: 3 usec Cell 3: -1usec			Cell 2: 3 usec Cell 3: -1usec		
Frequency Shift between Cells		Hz	Cell 2: 300Hz Cell 3: -100Hz			Cell 2: 300Hz Cell 3: -100Hz		
ABS pattern (Note 2)			N/A		01010101 01010101 01010101 01010101 01010101	N/A		01010101 01010101 01010101 01010101 01010101
RLM/RRM Measurement Subframe Pattern (Note 4)			00000100 00000100 00000100 00000100 00000100		N/A	00000100 00000100 00000100 00000100 00000100		N/A
CSI Subframe Sets (Note 3)	$C_{CSI,0}$		01010101 01010101 01010101 01010101 01010101		N/A	01010101 01010101 01010101 01010101 01010101		N/A
	$C_{CSI,1}$		10101010 10101010 10101010 10101010 10101010		N/A	10101010 10101010 10101010 10101010 10101010		N/A
Number of control OFDM symbols			3			3		
Max number of HARQ transmissions			1			1		
CQI delay		ms	8					
Reporting interval (Note 13)		ms	10					
Reporting mode			PUSCH 3-0					
Sub-band size		RB	6 (full size)					

Note 1:	For each test, the minimum requirements shall be fulfilled for at least one of the two SNR(s) and the respective wanted signal input level.
Note 2:	ABS pattern as defined in [9]. PDSCH other than SIB1/paging and its associated PDCCH/PCFICH are transmitted in the serving cell subframe when the subframe is overlapped with the ABS subframe of aggressor cell and the subframe is available in the definition of the reference channel.
Note 3:	Time-domain measurement resource restriction pattern for PCell measurements as defined in [7]
Note 4:	As configured according to the time-domain measurement resource restriction pattern for CSI measurements defined in [7]
Note 5:	Time-domain measurement resource restriction pattern for PCell measurements as defined in [7]
Note 6:	Cell 1 is the serving cell. Cell 2 and Cell 3 are the aggressor cells. The number of the CRS ports in Cell1, Cell2, and Cell3 are the same.
Note 7:	This noise is applied in OFDM symbols #1, #2, #3, #5, #6, #8, #9, #10,#12, #13 of a subframe overlapping with the aggressor ABS.
Note 8:	This noise is applied in OFDM symbols #0, #4, #7, #11 of a subframe overlapping with the aggressor ABS.
Note 9:	This noise is applied in all OFDM symbols of a subframe overlapping with aggressor non-ABS.
Note 10:	Downlink physical channel setup in Cell 2 and Cell 3 in accordance with Annex C.3.3 applying OCNB pattern as defined in Annex A.5.1.5
Note 11:	Reference measurement channel in Cell 1 RC.3 FDD according to Table A.4-1 with one/two sided dynamic OCNB Pattern OP.1/2 FDD as described in Annex A.5.1.1/2.
Note 12:	If the UE reports in an available uplink reporting instance at subframe SF#n based on CQI estimation at a downlink subframe not later than SF#(n-4), this reported subband or wideband CQI cannot be applied at the eNB downlink before SF#(n+4).
Note 13:	The CSI reporting is such that reference subframes belong to $C_{csi,0}$.

Table 9.3.1.1.3-2 Minimum requirement (FDD)

	Test 1	Test 2
α [%]	2	2
β [%]	55	55
γ	1.1	1.1
ϵ	0.01	0.01
UE Category	≥ 1	≥ 1

9.3.1.1.4 TDD (CSI measurements in case two CSI subframe sets are configured and with CRS assistance information)

For the parameters specified in Table 9.3.1.1.4-1, and using the downlink physical channels specified in Annex C.3.2, the minimum requirements are specified in Table 9.3.1.1.4-2 and by the following

- a sub-band differential CQI offset level of 0 shall be reported at least $\alpha\%$ of the time but less than $\beta\%$ for each sub-band;
- the ratio of the throughput in ABS subframes obtained when transmitting on a randomly selected sub-band among the sub-bands with the highest differential CQI offset level the corresponding TBS and that obtained when transmitting the TBS indicated by the reported wideband CQI median on a randomly selected sub-band in set S shall be $\geq \gamma$;
- when transmitting on a randomly selected sub-band among the sub-bands with the highest differential CQI offset level the corresponding TBS, the average BLER in ABS subframes for the indicated transport formats shall be greater than or equal to ϵ .

The requirements only apply for sub-bands of full size and the random scheduling across the sub-bands is done by selecting a new sub-band in each TTI for FDD, each available downlink transmission instance for TDD.

Table 9.3.1.1.4-1: Sub-band test for single antenna transmission (TDD)

Parameter	Unit	Test 1		Test 2			
		Cell 1	Cell 2 and 3	Cell 1	Cell 2 and 3		
Bandwidth	MHz	10		10			
PDSCH transmission mode		1	Note 10	1	Note 10		
Uplink downlink configuration		1		1			
Special subframe configuration		4		4			
Downlink power allocation	ρ_A	dB		0			
	ρ_B	dB		0			
	σ	dB		0			
Propagation condition		Clause B.2.4 with $T_d = 0.45$ μ s, $a = 1$, $f_d = 5$ Hz	EVA5 Low antenna correlation	Clause B.2.4 with $T_d = 0.45$ μ s, $a = 1$, $f_d = 5$ Hz	EVA5 Low antenna correlation		
Antenna configuration		1x2		1x2			
\hat{E}_s / N_{oc2} (Note 1)	dB	4	5	Cell 2: 12 Cell 3: 10	14 15 Cell 2: 12 Cell 3: 10		
$N_{oc}^{(j)}$ at antenna port	$N_{oc1}^{(j)}$	dBm/15kHz		-98 (Note 7)	N/A	-98 (Note 7)	N/A
	$N_{oc2}^{(j)}$	dBm/15kHz		-98 (Note 8)	N/A	-98 (Note 8)	N/A
	$N_{oc3}^{(j)}$	dBm/15kHz		-93 (Note 9)	N/A	-93 (Note 9)	N/A
Subframe Configuration		Non-MBSFN	Non-MBSFN	Non-MBSFN	Non-MBSFN		
Cell Id		0	Cell 2: 6 Cell 3: 1	0	Cell 2: 6 Cell 3: 1		
Time Offset between Cells	μ s	Cell 2: 3 usec Cell 3: -1usec		Cell 2: 3 usec Cell 3: -1usec			
Frequency shift between Cells	Hz	Cell 2: 300Hz Cell 3: -100Hz		Cell 2: 300Hz Cell 3: -100Hz			
ABS pattern (Note 2)		N/A	0100010001 0100010001	N/A	0100010001 0100010001		
RLM/RRM Measurement Subframe Pattern (Note 4)		0000000001 0000000001	N/A	0000000001 0000000001	N/A		
CSI Subframe Sets (Note 3)	$C_{CSI,0}$	0100010001 0100010001	N/A	0100010001 0100010001	N/A		
	$C_{CSI,1}$	1000101000 1000101000	N/A	1000101000 1000101000	N/A		
Number of control OFDM symbols		3		3			
Max number of HARQ transmissions		1		1			
CQI delay	ms	10					
Reporting interval (Note 13)	ms	10					
Reporting mode		PUSCH 3-0					
Sub-band size	RB	6 (full size)					
ACK/NACK feedback mode		Multiplexing		Multiplexing			

Note 1:	For each test, the minimum requirements shall be fulfilled for at least one of the two SNR(s) and the respective wanted signal input level.
Note 2:	ABS pattern as defined in [9]. PDSCH other than SIB1/paging and its associated PDCCH/PCFICH are transmitted in the serving cell subframe when the subframe is overlapped with the ABS subframe of aggressor cell and the subframe is available in the definition of the reference channel.
Note 3:	Time-domain measurement resource restriction pattern for PCell measurements as defined in [7]
Note 4:	As configured according to the time-domain measurement resource restriction pattern for CSI measurements defined in [7].
Note 5:	Time-domain measurement resource restriction pattern for PCell measurements as defined in [7]
Note 6:	Cell 1 is the serving cell. Cell 2 and Cell 3 are the aggressor cells. The number of the CRS ports in Cell1, Cell2, and Cell3 is the same.
Note 7:	This noise is applied in OFDM symbols #1, #2, #3, #5, #6, #8, #9, #10,#12, #13 of a subframe overlapping with the aggressor ABS.
Note 8:	This noise is applied in OFDM symbols #0, #4, #7, #11 of a subframe overlapping with the aggressor ABS
Note 9:	This noise is applied in all OFDM symbols of a subframe overlapping with aggressor non-ABS.
Note 10:	Downlink physical channel setup in Cell 2 and Cell 3 in accordance with Annex C.3.3 applying OCNG pattern as defined in Annex A.5.2.5
Note 11:	Reference measurement channel in Cell 1 RC.3 TDD according to Table A.4-1 with one/two sided dynamic OCNG Pattern OP.1/2 TDD as described in Annex A.5.2.1/2.
Note 12:	If the UE reports in an available uplink reporting instance at subframe SF#n based on CQI estimation at a downlink subframe not later than SF#(n-4), this reported subband or wideband CQI cannot be applied at the eNB downlink before SF#(n+4).
Note 13:	The CSI reporting is such that reference subframes belong to $C_{csi,0}$.

Table 9.3.1.1.4-2 Minimum requirement (TDD)

	Test 1	Test 2
α [%]	2	2
β [%]	55	55
γ	1.1	1.1
ε	0.01	0.01
UE Category	≥ 1	≥ 1

9.3.1.1.5 TDD (when *csi-SubframeSet* $-r12$ is configured)

The following requirements apply to UE Category ≥ 1 which supports Rel-12 CSI subframe sets. For the parameters specified in Table 9.3.1.1.5-1, and using the downlink physical channels specified in Annex C.3.2, the minimum requirements are specified in Table 9.3.1.1.5-2 and by the following

- a sub-band differential CQI offset level of 0 shall be reported at least α % of the time but less than β % for each sub-band for each CSI subframe set;
- the ratio of the throughput obtained when transmitting on a randomly selected sub-band among the sub-bands with the highest differential CQI offset level the corresponding TBS and that obtained when transmitting the TBS indicated by the reported wideband CQI median on a randomly selected sub-band in set S shall be $\geq \gamma$ for each CSI subframe set;
- when transmitting on a randomly selected sub-band among the sub-bands with the highest differential CQI offset level the corresponding TBS, the average BLER for the indicated transport formats shall be greater or equal to 0.05 and less than 0.60 for each CSI subframe set.
- the difference of the wide-band median CQI obtained by reports in CSI subframe sets $C_{csi,0}$ and the wide-band median CQI obtained by reports in CSI subframe sets $C_{csi,1}$ shall be larger than or equal to 3.

The requirements only apply for sub-bands of full size and the random scheduling across the sub-bands is done by selecting a new sub-band in each available downlink transmission instance. Sub-bands of a size smaller than full size are excluded from the test.

Table 9.3.1.1.5-1: Sub-band test for TDD

Parameter		Unit	Test	
Bandwidth		MHz	10	
Transmission mode			2	
Uplink downlink configuration			2	
Special subframe configuration			4	
CSI-MeasSubframeSet-r12			0001100000	
Downlink power allocation	ρ_A	dB	-3	
	ρ_B	dB	-3	
	σ	dB	0	
SNR in CSI subframe set 0		dB	0	1
SNR in CSI subframe set 1		dB	10	11
$\hat{I}_{or}^{(j)}$		dB[mW/15kHz]	-98	-97
$N_{oc1}^{(j)}$ for CSI subframe set 0		dB[mW/15kHz]	-98	-98
$N_{oc2}^{(j)}$ for CSI subframe set 1		dB[mW/15kHz]	-108	-108
Propagation channel			Clause B.2.4 with $\tau_d = 0.45 \mu s$, $a = 1$, $f_D = 5$ Hz	
Antenna configuration			2x2	
CRS reference signals			Antenna port 0 and 1	
Zero-Power CSI-RS configuration 0 $I_{CSI-RS} / ZeroPowerCSI-RS$ bitmap			3 / 0000010000000000	
Zero-Power CSI-RS configuration 1 $I_{CSI-RS} / ZeroPowerCSI-RS$ bitmap			4 / 0100000000000000	
PDSCH scheduled subframes for CSI subframe set 0			8,9	
PDSCH scheduled subframes for CSI subframe set 1			3,4	
Reporting interval (Note 4)		ms	10 per subframe set	
CQI delay		ms	15 for CSI subframe set 0 15 for CSI subframe set 1	
Reporting mode			PUSCH 3-0	
Sub-band size		RB	6 (full size)	
Max number of HARQ transmissions			1	
ACK/NACK feedback mode			Multiplexing	
Number of EPDCCH Sets Configured			2 (Note 5,6)	
Number of PRB per EPDCCH Set			4	
EPDCCH Subframe Monitoring			NA	
EPDCCH Aggregation level			8ECCE	
EPDCCH beamforming model			Annex B.4.4	
<p>Note 1: If the UE reports in an available uplink reporting instance at subframe SF#n based on CQI estimation at a downlink subframe not later than SF#(n-4), this reported subband or wideband CQI cannot be applied at the eNB downlink before SF#(n+4)</p> <p>Note 2: Reference measurement channel RC.17 TDD according to Table A.4-1 with one/two sided dynamic OCNG Pattern OP.1/2 TDD as described in Annex A.5.2.1/2.</p> <p>Note 3: In the test, the minimum requirements shall be fulfilled for at least one of the two SNR(s) and the respective wanted signal input level for each subframe set separately..</p> <p>Note 4: For CSI subframe set 0, PDCCH DCI format 0 with a trigger for aperiodic CQI shall be transmitted in downlink SF#3 to allow aperiodic CQI/PMI/RI to be transmitted on uplink SF #7. For CSI subframe set 1, PDCCH DCI format 0 with a trigger for aperiodic CQI shall be transmitted in downlink SF#8 to allow aperiodic CQI/PMI/RI to be transmitted on uplink SF#2.</p> <p>Note 5: In case UE supports EPDCCH, the PDSCH scheduling grants are transmitted via EPDCCH, otherwise PDCCH is used.</p> <p>Note 6: The two sets are distributed EPDCCH sets and non-overlapping with PRB = {0, 3, 6, 9} for the first set and PRB = {40, 43, 46, 49} for the second set. EPDCCH set is selected after scheduling decision for PDSCH to avoid collision between PDSCH and EPDCCH PRBs, respectively. EPDCCH is only transmitted from one set. The starting symbol for EPDCCH is derived from the PCFICH. RRC signalling epdcch-StartSymbol-r11 is not configured</p>				

Table 9.3.1.1.5-2: Minimum requirement (TDD)

	Test
α [%]	2
β [%]	55
γ	1.1
UE Category	≥ 1

9.3.1.2 Minimum requirement PUSCH 3-1 (CSI Reference Symbol)

9.3.1.2.1 FDD

For the parameters specified in Table 9.3.1.2.1-1, and using the downlink physical channels specified in Annex C.3.2, the minimum requirements are specified in Table 9.3.1.2.1-2 and by the following

- a) a sub-band differential CQI offset level of 0 shall be reported at least α % of the time but less than β % for each sub-band;
- b) the ratio of the throughput obtained when transmitting on a randomly selected sub-band among the sub-bands with the highest differential CQI offset level the corresponding TBS and that obtained when transmitting the TBS indicated by the reported wideband CQI median on a randomly selected sub-band in set S shall be $\geq \gamma$;
- c) when transmitting on a randomly selected sub-band among the sub-bands with the highest differential CQI offset level the corresponding TBS, the average BLER for the indicated transport formats shall be greater or equal to 0.05.

The requirements only apply for sub-bands of full size and the random scheduling across the sub-bands is done by selecting a new sub-band in each TTI for FDD, each available downlink transmission instance for TDD. Sub-bands of a size smaller than full size are excluded from the test.

Table 9.3.1.2.1-1 Sub-band test for FDD

Parameter		Unit	Test 1		Test 2	
Bandwidth		MHz	10 MHz			
Transmission mode			9			
Downlink power allocation	ρ_A	dB	0			
	ρ_B	dB	0			
	P_c	dB	0			
	σ	dB	0			
SNR (Note 3)		dB	4	5	11	12
$\hat{I}_{or}^{(j)}$		dB[mW/15kHz]	-94	-93	-87	-86
$N_{oc}^{(j)}$		dB[mW/15kHz]	-98		-98	
Propagation channel			Clause B.2.4 with $\tau_d = 0.45 \mu s$, $a = 1$, $f_D = 5$ Hz			
Antenna configuration			2x2			
Beamforming Model			As specified in Section B.4.3			
CRS reference signals			Antenna ports 0			
CSI reference signals			Antenna ports 15, 16			
CSI-RS periodicity and subframe offset $T_{CSI-RS} / \Delta_{CSI-RS}$			5/ 1			
CSI-RS reference signal configuration			4			
CodeBookSubsetRestriction bitmap			000001			
Reporting interval (Note 4)		ms	5			
CQI delay		ms	8			
Reporting mode			PUSCH 3-1			
Sub-band size		RB	6 (full size)			
Max number of HARQ transmissions			1			
<p>Note 1: If the UE reports in an available uplink reporting instance at subframe SF#n based on CQI estimation at a downlink subframe not later than SF#(n-4), this reported subband or wideband CQI cannot be applied at the eNB downlink before SF#(n+4)</p> <p>Note 2: Reference measurement channel RC.8 FDD according to Table A.4-1 with one/two sided dynamic OCNG Pattern OP.1/2 FDD as described in Annex A.5.1.1/2.</p> <p>Note 3: For each test, the minimum requirements shall be fulfilled for at least one of the two SNR(s) and the respective wanted signal input level.</p> <p>Note 4: PDCCH DCI format 0 with a trigger for aperiodic CQI shall be transmitted in downlink SF#1 and #6 to allow aperiodic CQI/PMI/RI to be transmitted in uplink SF#0 and #5.</p>						

Table 9.3.1.2.1-2 Minimum requirement (FDD)

	Test 1	Test 2
α [%]	2	2
β [%]	40	40
γ	1.1	1.1
UE Category	≥ 1	≥ 1

9.3.1.2.2 TDD

For the parameters specified in Table 9.3.1.2.2-1, and using the downlink physical channels specified in Annex C.3.2, the minimum requirements are specified in Table 9.3.1.2.2-2 and by the following

- a sub-band differential CQI offset level of 0 shall be reported at least α % of the time but less than β % for each sub-band;
- the ratio of the throughput obtained when transmitting on a randomly selected sub-band among the sub-bands with the highest differential CQI offset level the corresponding TBS and that obtained when transmitting the TBS indicated by the reported wideband CQI median on a randomly selected sub-band in set S shall be $\geq \gamma$;

- c) when transmitting on a randomly selected sub-band among the sub-bands with the highest differential CQI offset level the corresponding TBS, the average BLER for the indicated transport formats shall be greater or equal to 0.05.

The requirements only apply for sub-bands of full size and the random scheduling across the sub-bands is done by selecting a new sub-band in each TTI for FDD, each available downlink transmission instance for TDD. Sub-bands of a size smaller than full size are excluded from the test.

Table 9.3.1.2.2-1 Sub-band test for TDD

Parameter		Unit	Test 1		Test 2	
Bandwidth		MHz	10 MHz			
Transmission mode			9			
Uplink downlink configuration			2			
Special subframe configuration			4			
Downlink power allocation	ρ_A	dB	0			
	ρ_B	dB	0			
	P_c	dB	0			
	σ	dB	0			
SNR (Note 3)		dB	4	5	11	12
$\hat{I}_{or}^{(j)}$		dB[mW/15kHz]	-94	-93	-87	-86
$N_{oc}^{(j)}$		dB[mW/15kHz]	-98		-98	
Propagation channel			Clause B.2.4 with $\tau_d = 0.45 \mu s$, $a = 1, f_D = 5 \text{ Hz}$			
Antenna configuration			2x2			
Beamforming Model			As specified in Section B.4.3			
CRS reference signals			Antenna port 0			
CSI reference signals			Antenna port 15,16			
CSI-RS periodicity and subframe offset $T_{CSI-RS} / \Delta_{CSI-RS}$			5/ 3			
CSI-RS reference signal configuration			4			
CodeBookSubsetRestriction bitmap			000001			
Reporting interval (Note 4)		ms	5			
CQI delay		ms	10			
Reporting mode			PUSCH 3-1			
Sub-band size		RB	6 (full size)			
Max number of HARQ transmissions			1			
ACK/NACK feedback mode			Multiplexing			
Note 1: If the UE reports in an available uplink reporting instance at subframe SF#n based on CQI estimation at a downlink subframe not later than SF#(n-4), this reported subband or wideband CQI cannot be applied at the eNB downlink before SF#(n+4) Note 2: Reference measurement channel RC.8 TDD according to Table A.4-1 with one/two sided dynamic OCNG Pattern OP.1/2 TDD as described in Annex A.5.2.1/2. Note 3: For each test, the minimum requirements shall be fulfilled for at least one of the two SNR(s) and the respective wanted signal input level. Note 4: PDCCH DCI format 0 with a trigger for aperiodic CQI shall be transmitted in downlink SF#3 and #8 to allow aperiodic CQI/PMI/RI to be transmitted on uplink SF#2 and #7.						

Table 9.3.1.2.2-2 Minimum requirement (TDD)

	Test 1	Test 2
α [%]	2	2
β [%]	40	40
γ	1.1	1.1
UE Category	≥ 1	≥ 1

9.3.1.2.3 FDD (Modulation and TBS index Table 2 and 4-bit CQI Table 2 are used)

For the parameters specified in Table 9.3.1.2.3-1, and using the downlink physical channels specified in Annex C.3.2, the minimum requirements are specified in Table 9.3.1.2.3-2 and by the following

- a sub-band differential CQI offset level of 0 shall be reported at least $\alpha\%$ of the time but less than $\beta\%$ for each sub-band;
- the ratio of the throughput obtained when transmitting on a randomly selected sub-band among the sub-bands with the highest differential CQI offset level the corresponding TBS and that obtained when transmitting the TBS indicated by the reported wideband CQI median on a randomly selected sub-band in set S shall be $\geq \gamma$;
- when transmitting on a randomly selected sub-band among the sub-bands with the highest differential CQI offset level the corresponding TBS, the average BLER for the indicated transport formats shall be greater or equal to 0.05.

The requirements only apply for sub-bands of full size and the random scheduling across the sub-bands is done by selecting a new sub-band in each TTI for FDD, each available downlink transmission instance for TDD. Sub-bands of a size smaller than full size are excluded from the test.

In this test, 4-bit CQI Table 2 in Table 7.2.3-2 in TS 36.213 [6], and Modulation and TBS index table 2 in Table 7.1.7.1-1A for PDSCH in TS 36.213 [6] are applied.

Table 9.3.1.2.3-1 Sub-band test for FDD

Parameter	Unit	Test 1	
Bandwidth	MHz	10 MHz	
Transmission mode		9	
Downlink power allocation	ρ_A	dB	0
	ρ_B	dB	0
	P_c	dB	0
	σ	dB	0
SNR (Note 3)	dB	16	17
$\hat{I}_{or}^{(j)}$	dB[mW/15kHz]	-82	-81
$N_{oc}^{(j)}$	dB[mW/15kHz]	-98	-98
Propagation channel		Clause B.2.4 with $\tau_d = 0.45 \mu s$, $a = 1$, $f_D = 5$ Hz	
Antenna configuration		2x2	
Beamforming Model		As specified in Section B.4.3	
CRS reference signals		Antenna ports 0	
CSI reference signals		Antenna ports 15, 16	
CSI-RS periodicity and subframe offset $T_{CSI-RS} / \Delta_{CSI-RS}$		5/ 1	
CSI-RS reference signal configuration		4	
CodeBookSubsetRestriction bitmap		000001	
Reporting interval (Note 4)	ms	5	
CQI delay	ms	8	
Reporting mode		PUSCH 3-1	
Sub-band size	RB	6 (full size)	
Max number of HARQ transmissions		1	
Note 1:	If the UE reports in an available uplink reporting instance at subframe SF#n based on CQI estimation at a downlink subframe not later than SF#(n-4), this reported subband or wideband CQI cannot be applied at the eNB downlink before SF#(n+4)		
Note 2:	Reference measurement channel RC.8A FDD according to Table A.4-1 with one/two sided dynamic OCN Pattern OP.1/2 FDD as described in Annex A.5.1.1/2.		
Note 3:	For each test, the minimum requirements shall be fulfilled for at least one of the two SNR(s) and the respective wanted signal input level.		
Note 4:	PDCCH DCI format 0 with a trigger for aperiodic CQI shall be transmitted in downlink SF#1 and #6 to allow aperiodic CQI/PMI/RI to be transmitted in uplink SF#0 and #5.		

Table 9.3.1.2.3-2 Minimum requirement (FDD)

	Test 1
α [%]	2
β [%]	40
γ	1.1
UE Category	11-12
UE DL Category	≥ 11

9.3.1.2.4 TDD (Modulation and TBS index Table 2 and 4-bit CQI Table 2 are used)

For the parameters specified in Table 9.3.1.2.4-1, and using the downlink physical channels specified in Annex C.3.2, the minimum requirements are specified in Table 9.3.1.2.4-2 and by the following

- a sub-band differential CQI offset level of 0 shall be reported at least α % of the time but less than β % for each sub-band;
- the ratio of the throughput obtained when transmitting on a randomly selected sub-band among the sub-bands with the highest differential CQI offset level the corresponding TBS and that obtained when transmitting the TBS indicated by the reported wideband CQI median on a randomly selected sub-band in set S shall be $\geq \gamma$;
- when transmitting on a randomly selected sub-band among the sub-bands with the highest differential CQI offset level the corresponding TBS, the average BLER for the indicated transport formats shall be greater or equal to 0.05.

The requirements only apply for sub-bands of full size and the random scheduling across the sub-bands is done by selecting a new sub-band in each TTI for FDD, each available downlink transmission instance for TDD. Sub-bands of a size smaller than full size are excluded from the test.

In this test, 4-bit CQI Table 2 in Table 7.2.3-2 in TS 36.213 [6], and Modulation and TBS index table 2 in Table 7.1.7.1-1A for PDSCH in TS 36.213 [6] are applied.

Table 9.3.1.2.4-1 Sub-band test for TDD

Parameter		Unit	Test 1
Bandwidth		MHz	20 MHz
Transmission mode			9
Uplink downlink configuration			2
Special subframe configuration			4
Downlink power allocation	ρ_A	dB	0
	ρ_B	dB	0
	P_c	dB	0
	σ	dB	0

SNR (Note 3)	dB	16	17
$\hat{I}_{or}^{(j)}$	dB[mW/15kHz]	-82	-81
$N_{oc}^{(j)}$	dB[mW/15kHz]	-98	-98
Propagation channel		Clause B.2.4 with $\tau_d = 0.45 \mu\text{s}$, $a = 1$, $f_D = 5 \text{ Hz}$	
Antenna configuration		2x2	
Beamforming Model		As specified in Section B.4.3	
CRS reference signals		Antenna port 0	
CSI reference signals		Antenna port 15,16	
CSI-RS periodicity and subframe offset $T_{\text{CSI-RS}} / \Delta_{\text{CSI-RS}}$		5/ 3	
CSI-RS reference signal configuration		4	
CodeBookSubsetRestriction bitmap		000001	
Reporting interval (Note 4)	ms	5	
CQI delay	ms	10	
Reporting mode		PUSCH 3-1	
Sub-band size	RB	8 (full size)	
Max number of HARQ transmissions		1	
ACK/NACK feedback mode		Multiplexing	
<p>Note 1: If the UE reports in an available uplink reporting instance at subframe SF#n based on CQI estimation at a downlink subframe not later than SF#(n-4), this reported subband or wideband CQI cannot be applied at the eNB downlink before SF#(n+4)</p> <p>Note 2: Reference measurement channel RC.8A TDD according to Table A.4-1 with one/two sided dynamic OCNG Pattern OP.1/2 TDD as described in Annex A.5.2.1/2.</p> <p>Note 3: For each test, the minimum requirements shall be fulfilled for at least one of the two SNR(s) and the respective wanted signal input level.</p> <p>Note 4: PDCCH DCI format 0 with a trigger for aperiodic CQI shall be transmitted in downlink SF#3 and #8 to allow aperiodic CQI/PMI/RI to be transmitted on uplink SF#2 and #7.</p>			

Table 9.3.1.2.4-2 Minimum requirement (TDD)

	Test 1
α [%]	2
β [%]	40
γ	1.1
UE Category	11-12
UE DL Category	≥ 11

9.3.1.2.5 Void

9.3.1.2.6 TDD (when *csi-SubframeSet* –r12 is configured with one CSI process)

The following requirements apply to UE Category ≥ 1 which supports Rel-12 CSI subframe sets and TM10. For the parameters specified in Table 9.3.1.2.6-1, and using the downlink physical channels specified in Annex C.3.2, the minimum requirements are specified in Table 9.3.1.2.6-2 and by the following

- a sub-band differential CQI offset level of 0 shall be reported at least α % of the time but less than β % for each sub-band for each CSI subframe set;
- the ratio of the throughput obtained when transmitting on a randomly selected sub-band among the sub-bands with the highest differential CQI offset level the corresponding TBS and that obtained when transmitting the TBS indicated by the reported wideband CQI median on a randomly selected sub-band in set S shall be $\geq \gamma$ for each CSI subframe set;
- when transmitting on a randomly selected sub-band among the sub-bands with the highest differential CQI offset level the corresponding TBS, the average BLER for the indicated transport formats shall be greater or equal to 0.01 for each CSI subframe set.

- d) The difference of the wide-band median CQI obtained by reports in CSI subframe sets $C_{\text{CSI},0}$ and the wide-band median CQI obtained by reports in CSI subframe sets $C_{\text{CSI},1}$ shall be larger than or equal to 3.

The requirements only apply for sub-bands of full size and the random scheduling across the sub-bands is done by selecting a new sub-band in each available downlink transmission instance. Sub-bands of a size smaller than full size are excluded from the test.

Table 9.3.1.2.6-1: Sub-band test for TDD

Parameter		Unit	Test	
Bandwidth		MHz	10	
Transmission mode			10	
Uplink downlink configuration			2	
Special subframe configuration			4	
CSI-MeasSubframeSet-r12			0001100000	
Downlink power allocation	ρ_A	dB	0	
	ρ_B	dB	0	
	P_C	dB	-3	
	σ	dB	-3	
SNR in CSI subframe set 0		dB	0	1
SNR in CSI subframe set 1		dB	10	11
$\hat{I}_{or}^{(j)}$		dB[mW/15kHz]	-98	-97
$N_{oc1}^{(j)}$ for CSI subframe set 0		dB[mW/15kHz]	-98	-98
$N_{oc2}^{(j)}$ for CSI subframe set 1		dB[mW/15kHz]	-108	-108
Propagation channel			Clause B.2.4 with $\tau_d = 0.45 \mu\text{s}$, $a = 1$, $f_D = 5 \text{ Hz}$	
Antenna configuration			2x2	
Beamforming Model			As specified in Section B.4.3	
CRS reference signals			Antenna port 0 and 1	
CSI reference signals			Antenna port 15,16	
CSI-RS periodicity and subframe offset $T_{\text{CSI-RS}} / \Delta_{\text{CSI-RS}}$			5/ 0	
CSI-RS reference signal configuration			0	
Zero-Power CSI-RS configuration 0 $l_{\text{CSI-RS}} / \text{ZeroPowerCSI-RS}$ bitmap			3 / 0000010000000000	
Zero-Power CSI-RS configuration 1 $l_{\text{CSI-RS}} / \text{ZeroPowerCSI-RS}$ bitmap			4 / 0100000000000000	
CSI-IM configuration 0 $l_{\text{CSI-RS}} / \text{ZeroPowerCSI-RS}$ bitmap			3 / 0000010000000000	
CSI-IM configuration 1 $l_{\text{CSI-RS}} / \text{ZeroPowerCSI-RS}$ bitmap			4 / 0100000000000000	
CSI process configuration Signal/Interference/Reporting mode for CSI subframe set 0			CSI-RS/CSI-IM 0/PUSCH 3-1	
CSI process configuration Signal/Interference/Reporting mode for CSI subframe set 1			CSI-RS/CSI-IM 1/PUSCH 3-1	
CodeBookSubsetRestriction bitmap			000001	
Reporting interval (Note 4)		ms	10 per subframe set	
CQI delay		ms	15 for CSI subframe set 0 15 for CSI subframe set 1	
Sub-band size		RB	6 (full size)	
PDSCH scheduled subframes for CSI subframe set 0			8,9	
PDSCH scheduled subframes for CSI subframe set 1			3,4	
Max number of HARQ transmissions			1	
ACK/NACK feedback mode			Multiplexing	
Note 1: If the UE reports in an available uplink reporting instance at subframe SF#n based on CQI estimation at a downlink subframe not later than SF#(n-4), this reported subband or wideband CQI cannot be applied at the eNB downlink before SF#(n+4)				
Note 2: Reference measurement channel RC.18 TDD according to Table A.4-1 with one/two sided dynamic OCN Pattern OP.1/2 TDD as described in Annex A.5.2.1/2.				
Note 3: For each test, the minimum requirements shall be fulfilled for at least one of the two SNR(s) and the respective wanted signal input level for each subframe set separately.				
Note 4: For CSI subframe set 0, PDCCH DCI format 0 with a trigger for aperiodic CQI/PMI/RI shall be transmitted in downlink SF#3 to allow aperiodic CQI/PMI/RI to be transmitted on uplink SF #7. For CSI subframe set 1, PDCCH DCI format 0 with a trigger for aperiodic CQI shall be transmitted in downlink SF#8 to allow aperiodic CQI/PMI/RI to be transmitted				

on uplink SF#2.

Table 9.3.1.2.6-2: Minimum requirement (TDD)

	Test
α [%]	2
β [%]	55
γ	1.02
UE Category	≥ 1

9.3.2 Frequency non-selective scheduling mode

The reporting accuracy of the channel quality indicator (CQI) under frequency non-selective fading conditions is determined by the reporting variance, and the relative increase of the throughput obtained when the transport format transmitted is that indicated by the reported CQI compared to the case for which a fixed transport format configured according to the reported median CQI is transmitted. In addition, the reporting accuracy is determined by a minimum BLER using the transport formats indicated by the reported CQI. The purpose is to verify that the UE is tracking the channel variations and selecting the largest transport format possible according to the prevailing channel state for frequently non-selective scheduling. To account for sensitivity of the input SNR the CQI reporting under frequency non-selective fading conditions is considered to be verified if the reporting accuracy is met for at least one of two SNR levels separated by an offset of 1 dB.

9.3.2.1 Minimum requirement PUCCH 1-0 (Cell-Specific Reference Symbol)

9.3.2.1.1 FDD

For the parameters specified in Table 9.3.2.1.1-1 and Table 9.3.2.1.1-3, and using the downlink physical channels specified in Annex C.3.2, the minimum requirements are specified in Table 9.3.2.1.1-2 and Table 9.3.2.1.1-4 and by the following

- a) a CQI index not in the set {median CQI -1, median CQI, median CQI +1} shall be reported at least α % of the time;
- b) the ratio of the throughput obtained when transmitting the transport format indicated by each reported wideband CQI index and that obtained when transmitting a fixed transport format configured according to the wideband CQI median shall be $\geq \gamma$;
- c) when transmitting the transport format indicated by each reported wideband CQI index, the average BLER for the indicated transport formats shall be greater or equal to 0.02

The applicability of the requirement with 5MHz bandwidth as specified in Table 9.3.2.1.1-3 and Table 9.3.2.1.1-4 is defined in 9.1.1.1.

Table 9.3.2.1.1-1 Fading test for single antenna (FDD)

Parameter		Unit	Test 1		Test 2	
Bandwidth		MHz	10 MHz			
Transmission mode			1 (port 0)			
Downlink power allocation	ρ_A	dB	0			
	ρ_B	dB	0			
	σ	dB	0			
SNR (Note 3)		dB	6	7	12	13
$\hat{I}_{or}^{(j)}$		dB[mW/15kHz]	-92	-91	-86	-85
$N_{oc}^{(j)}$		dB[mW/15kHz]	-98		-98	
Propagation channel			EPA5			
Correlation and antenna configuration			High (1 x 2)			
Reporting mode			PUCCH 1-0			
Reporting periodicity		ms	$N_{pd} = 2$			
CQI delay		ms	8			
Physical channel for CQI reporting			PUSCH (Note 4)			
PUCCH Report Type			4			
<i>cqi-pmi-ConfigurationIndex</i>			1			
Max number of HARQ transmissions			1			
<p>Note 1: If the UE reports in an available uplink reporting instance at subframe SF#n based on CQI estimation at a downlink SF not later than SF#(n-4), this reported wideband CQI cannot be applied at the eNB downlink before SF#(n+4)</p> <p>Note 2: Reference measurement channel RC.1 FDD according to Table A.4-1 for Category 2-8 with one sided dynamic OCNG Pattern OP.1 FDD as described in Annex A.5.1.1 and RC.4 FDD according to Table A.4-1 for Category 1 with one/two sided dynamic OCNG Pattern OP.1/2 FDD as described in Annex A.5.1.1/2.</p> <p>Note 3: For each test, the minimum requirements shall be fulfilled for at least one of the two SNR(s) and the respective wanted signal input level.</p> <p>Note 4: To avoid collisions between CQI reports and HARQ-ACK it is necessary to report both on PUSCH instead of PUCCH. PDCCH DCI format 0 shall be transmitted in downlink SF#1, #3, #7 and #9 to allow periodic CQI to multiplex with the HARQ-ACK on PUSCH in uplink subframe SF#5, #7, #1 and #3.</p>						

Table 9.3.2.1.1-2 Minimum requirement (FDD)

	Test 1	Test 2
α [%]	20	20
γ	1.05	1.05
UE Category	≥ 1	≥ 1

Table 9.3.2.1.1-3 Fading test for single antenna (FDD)

Parameter		Unit	Test 1		Test 2	
Bandwidth		MHz	5 MHz			
Transmission mode			1 (port 0)			
Downlink power allocation	ρ_A	dB	0			
	ρ_B	dB	0			
	σ	dB	0			
SNR (Note 3)		dB	6	7	12	13
$\hat{I}_{or}^{(j)}$		dB[mW/15kHz]	-92	-91	-86	-85
$N_{oc}^{(j)}$		dB[mW/15kHz]	-98		-98	
Propagation channel			EPA5			
Correlation and antenna configuration			High (1 x 2)			
Reporting mode			PUCCH 1-0			
Reporting periodicity		ms	$N_{pd} = 2$			
CQI delay		ms	8			
Physical channel for CQI reporting			PUSCH (Note 4)			
PUCCH Report Type			4			
<i>cqi-pmi-ConfigurationIndex</i>			1			
Max number of HARQ transmissions			1			
<p>Note 1: If the UE reports in an available uplink reporting instance at subframe SF#n based on CQI estimation at a downlink SF not later than SF#(n-4), this reported wideband CQI cannot be applied at the eNB downlink before SF#(n+4)</p> <p>Note 2: Reference measurement channel RC.14 FDD according to Table A.4-1 for Category ≥ 2 with one sided dynamic OCNG Pattern OP.1 FDD as described in Annex A.5.1.1 and RC.15 FDD according to Table A.4-1 for Category 1 with one/two sided dynamic OCNG Pattern OP.1/2 FDD as described in Annex A.5.1.1/2. Note 3: For each test, the minimum requirements shall be fulfilled for at least one of the two SNR(s) and the respective wanted signal input level.</p> <p>Note 4: To avoid collisions between CQI reports and HARQ-ACK it is necessary to report both on PUSCH instead of PUCCH. PDCCH DCI format 0 shall be transmitted in downlink SF#1, #3, #7 and #9 to allow periodic CQI to multiplex with the HARQ-ACK on PUSCH in uplink subframe SF#5, #7, #1 and #3.</p>						

Table 9.3.2.1.1-4 Minimum requirement (FDD)

	Test 1	Test 2
α [%]	20	20
γ	1.05	1.05
UE Category	≥ 1	≥ 1

9.3.2.1.2 TDD

For the parameters specified in Table 9.3.2.1.2-1, and using the downlink physical channels specified in Annex C.3.2, the minimum requirements are specified in Table 9.3.2.1.2-2 and by the following

- a CQI index not in the set {median CQI -1, median CQI, median CQI +1} shall be reported at least $\alpha\%$ of the time;
- the ratio of the throughput obtained when transmitting the transport format indicated by each reported wideband CQI index and that obtained when transmitting a fixed transport format configured according to the wideband CQI median shall be $\geq \gamma$;
- when transmitting the transport format indicated by each reported wideband CQI index, the average BLER for the indicated transport formats shall be greater or equal to 0.02.

Table 9.3.2.1.2-1 Fading test for single antenna (TDD)

Parameter		Unit	Test 1		Test 2	
Bandwidth		MHz	10 MHz			
Transmission mode			1 (port 0)			
Downlink power allocation	ρ_A	dB	0			
	ρ_B	dB	0			
	σ	dB	0			
Uplink downlink configuration			2			
Special subframe configuration			4			
SNR (Note 3)		dB	6	7	12	13
$\hat{I}_{or}^{(j)}$		dB[mW/15kHz]	-92	-91	-86	-85
$N_{oc}^{(j)}$		dB[mW/15kHz]	-98		-98	
Propagation channel			EPA5			
Correlation and antenna configuration			High (1 x 2)			
Reporting mode			PUCCH 1-0			
Reporting periodicity		ms	$N_{pd} = 5$			
CQI delay		ms	10 or 11			
Physical channel for CQI reporting			PUSCH (Note 4)			
PUCCH Report Type			4			
<i>cqi-pmi-ConfigurationIndex</i>			3			
Max number of HARQ transmissions			1			
ACK/NACK feedback mode			Multiplexing			
<p>Note 1: If the UE reports in an available uplink reporting instance at subframe SF#n based on CQI estimation at a downlink SF not later than SF#(n-4), this reported wideband CQI cannot be applied at the eNB downlink before SF#(n+4).</p> <p>Note 2: Reference measurement channel RC.1 TDD according to Table A.4-1 for Category 2-8 with one sided dynamic OCNG Pattern OP.1 TDD as described in Annex A.5.2.1 and RC.4 TDD according to Table A.4-1 for Category 1 with one/two sided dynamic OCNG Pattern OP.1/2 TDD as described in Annex A.5.2.1/2.</p> <p>Note 3: For each test, the minimum requirements shall be fulfilled for at least one of the two SNR(s) and the respective wanted signal input level.</p> <p>Note 4: To avoid collisions between CQI reports and HARQ-ACK it is necessary to report both on PUSCH instead of PUCCH. PDCCH DCI format 0 shall be transmitted in downlink SF#3 and #8 to allow periodic CQI to multiplex with the HARQ-ACK on PUSCH in uplink subframe SF#7 and #2.</p>						

Table 9.3.2.1.2-2 Minimum requirement (TDD)

	Test 1	Test 2
α [%]	20	20
γ	1.05	1.05
UE Category	≥ 1	≥ 1

9.3.2.2 Minimum requirement PUCCH 1-1 (CSI Reference Symbol)

9.3.2.2.1 FDD

For the parameters specified in Table 9.3.2.2.1-1, and using the downlink physical channels specified in Annex C.3.2, the minimum requirements are specified in Table 9.3.2.2.1-2 and by the following

- a CQI index not in the set {median CQI -1, median CQI, median CQI +1} shall be reported at least $\alpha\%$ of the time;
- the ratio of the throughput obtained when transmitting the transport format indicated by each reported wideband CQI index and that obtained when transmitting a fixed transport format configured according to the wideband CQI median shall be $\geq \gamma$;
- when transmitting the transport format indicated by each reported wideband CQI index, the average BLER for the indicated transport formats shall be greater or equal to 0.02.

Table 9.3.2.2.1-1 Fading test for FDD

Parameter		Unit	Test 1		Test 2	
Bandwidth		MHz	10 MHz			
Transmission mode			9			
Downlink power allocation	ρ_A	dB	0			
	ρ_B	dB	0			
	P_C	dB	-3			
	σ	dB	-3			
SNR (Note 3)		dB	2	3	7	8
$\hat{I}_{or}^{(j)}$		dB[mW/15kHz]	-96	-95	-91	-90
$N_{oc}^{(j)}$		dB[mW/15kHz]	-98		-98	
Propagation channel			EPA5			
Correlation and antenna configuration			ULA High (4 x 2)			
Beamforming Model			As specified in Section B.4.3			
Cell-specific reference signals			Antenna ports 0,1			
CSI reference signals			Antenna ports 15,...,18			
CSI-RS periodicity and subframe offset $T_{CSI-RS} / \Delta_{CSI-RS}$			5/1			
CSI-RS reference signal configuration			2			
CodeBookSubsetRestriction bitmap			0x0000 0000 0000 0001			
Reporting mode			PUCCH 1-1			
Reporting periodicity		ms	$N_{pd} = 5$			
CQI delay		ms	8			
Physical channel for CQI/ PMI reporting			PUSCH (Note 4)			
PUCCH Report Type for CQI/PMI			2			
PUCCH channel for RI reporting			PUCCH Format 2			
PUCCH report type for RI			3			
<i>cqi-pmi-ConfigurationIndex</i>			2			
<i>ri-ConfigIndex</i>			1			
Max number of HARQ transmissions			1			
<p>Note 1: If the UE reports in an available uplink reporting instance at subframe SF#n based on CQI estimation at a downlink SF not later than SF#(n-4), this reported wideband CQI cannot be applied at the eNB downlink before SF#(n+4)</p> <p>Note 2: Reference measurement channel RC.7 FDD according to Table A.4-1 with one sided dynamic OCNG Pattern OP.1 FDD as described in Annex A.5.1.1.</p> <p>Note 3: For each test, the minimum requirements shall be fulfilled for at least one of the two SNR(s) and the respective wanted signal input level.</p> <p>Note 4: To avoid collisions between CQI/ PMI reports and HARQ-ACK it is necessary to report both on PUSCH instead of PUCCH. PDCCH DCI format 0 shall be transmitted in downlink SF#1 and #6 to allow periodic CQI/ PMI to multiplex with the HARQ-ACK on PUSCH in uplink subframe SF#0 and #5.</p>						

Table 9.3.2.2.1-2 Minimum requirement (FDD)

	Test 1	Test 2
α [%]	20	20
γ	1.05	1.05
UE Category	≥ 2	≥ 2

9.3.2.2.2 TDD

For the parameters specified in Table 9.3.2.2.2-1, and using the downlink physical channels specified in Annex C.3.2, the minimum requirements are specified in Table 9.3.2.2.2-2 and by the following

- a) a CQI index not in the set {median CQI -1, median CQI, median CQI +1} shall be reported at least α % of the time;
- b) the ratio of the throughput obtained when transmitting the transport format indicated by each reported wideband CQI index and that obtained when transmitting a fixed transport format configured according to the wideband CQI median shall be $\geq \gamma$;
- c) when transmitting the transport format indicated by each reported wideband CQI index, the average BLER for the indicated transport formats shall be greater or equal to 0.02.

Table 9.3.2.2-1 Fading test for TDD

Parameter		Unit	Test 1		Test 2	
Bandwidth		MHz	10 MHz			
Transmission mode			9			
Uplink downlink configuration			2			
Special subframe configuration			4			
Downlink power allocation	ρ_A	dB	0			
	ρ_B	dB	0			
	P_C	dB	-6			
	σ	dB	-3			
SNR (Note 3)		dB	1	2	7	8
$\hat{I}_{or}^{(j)}$		dB[mW/15kHz]	-97	-96	-91	-90
$N_{oc}^{(j)}$		dB[mW/15kHz]	-98		-98	
Propagation channel			EPA5			
Correlation and antenna configuration			XP High (8 x 2)			
Beamforming Model			As specified in Section B.4.3			
CRS reference signals			Antenna ports 0, 1			
CSI reference signals			Antenna ports 15,...,22			
CSI-RS periodicity and subframe offset $T_{CSI-RS} / \Delta_{CSI-RS}$			5/ 3			
CSI-RS reference signal configuration			2			
CodeBookSubsetRestriction bitmap			0x0000 0000 0000 0020 0000 0000 0001			
Reporting mode			PUCCH 1-1 (Sub-mode: 2)			
Reporting periodicity		ms	$N_{pd} = 5$			
CQI delay		ms	10			
Physical channel for CQI/ PMI reporting			PUSCH (Note 4)			
PUCCH Report Type for CQI/ PMI			2c			
Physical channel for RI reporting			PUCCH Format 2			
PUCCH report type for RI			3			
<i>cqi-pmi-ConfigurationIndex</i>			3			
<i>ri-ConfigIndex</i>			805 (Note 5)			
Max number of HARQ transmissions			1			
ACK/NACK feedback mode			Multiplexing			
<p>Note 1: If the UE reports in an available uplink reporting instance at subframe SF#n based on CQI estimation at a downlink SF not later than SF#(n-4), this reported wideband CQI cannot be applied at the eNB downlink before SF#(n+4)</p> <p>Note 2: Reference measurement channel RC.7 TDD according to Table A.4-1 with one sided dynamic OCNG Pattern OP.1 TDD as described in Annex A.5.2.1.</p> <p>Note 3: For each test, the minimum requirements shall be fulfilled for at least one of the two SNR(s) and the respective wanted signal input level.</p> <p>Note 4: To avoid collisions between CQI/ PMI reports and HARQ-ACK it is necessary to report both on PUSCH instead of PUCCH. PDCCH DCI format 0 shall be transmitted in downlink SF#3 and #8 to allow periodic CQI/ PMI to multiplex with the HARQ-ACK on PUSCH in uplink subframe SF#2 and #7.</p> <p>Note 5: RI reporting interval is set to the maximum allowable length of 160ms to minimise collisions between RI, CQI/PMI and HARQ-ACK reports. In the case when all three reports collide, it is expected that CQI/PMI reports will be dropped, while RI and HARQ-ACK will be multiplexed. At eNB, CQI report collection shall be skipped every 160ms during performance verification and the reported CQI in subframe SF#7 of the previous frame is applied in downlink subframes until a new CQI (after CQI/PMI dropping) is available.</p>						

Table 9.3.2.2-2 Minimum requirement (TDD)

	Test 1	Test 2
α [%]	20	20
γ	1.05	1.05
UE Category	≥ 2	≥ 2

9.3.3 Frequency-selective interference

The accuracy of sub-band channel quality indicator (CQI) reporting under frequency selective interference conditions is determined by a percentile of the reported differential CQI offset level +2 for a preferred sub-band, and the relative increase of the throughput obtained when transmitting on a randomly selected sub-band among the sub-bands with the highest reported differential CQI offset level the corresponding transport format compared to the case for which a fixed format is transmitted on any sub-band in set S of TS 36.213 [6]. The purpose is to verify that preferred sub-bands are used for frequently-selective scheduling under frequency-selective interference conditions.

9.3.3.1 Minimum requirement PUSCH 3-0 (Cell-Specific Reference Symbol)

9.3.3.1.1 FDD

For the parameters specified in Table 9.3.3.1.1-1, and using the downlink physical channels specified in Annex C.3.2, the minimum requirements are specified in Table 9.3.3.1.1-2 and by the following

- a sub-band differential CQI offset level of +2 shall be reported at least $\alpha\%$ for at least one of the sub-bands of full size at the channel edges;
- the ratio of the throughput obtained when transmitting on a randomly selected sub-band among the sub-bands with the highest differential CQI offset level the corresponding TBS and that obtained when transmitting the TBS indicated by the reported wideband CQI median on a randomly selected sub-band in set S shall be $\geq \gamma$;

The requirements only apply for sub-bands of full size and the random scheduling across the sub-bands is done by selecting a new sub-band in each TTI for FDD, each available downlink transmission instance for TDD. Sub-bands of a size smaller than full size are excluded from the test.

Table 9.3.3.1.1-1 Sub-band test for single antenna transmission (FDD)

Parameter		Unit	Test 1	Test 2
Bandwidth		MHz	10 MHz	10 MHz
Transmission mode			1 (port 0)	1 (port 0)
Downlink power allocation	ρ_A	dB	0	0
	ρ_B	dB	0	0
	σ	dB	0	0
$I_{ot}^{(j)}$ for RB 0...5		dB[mW/15kHz]	-102	-93
$I_{ot}^{(j)}$ for RB 6...41		dB[mW/15kHz]	-93	-93
$I_{ot}^{(j)}$ for RB 42...49		dB[mW/15kHz]	-93	-102
$\hat{I}_{or}^{(j)}$		dB[mW/15kHz]	-94	-94
Max number of HARQ transmissions			1	
Propagation channel			Clause B.2.4 with $\tau_d = 0.45 \mu s$, $a = 1$, $f_D = 5$ Hz	
Reporting interval		ms	5	
Antenna configuration			1 x 2	
CQI delay		ms	8	
Reporting mode			PUSCH 3-0	
Sub-band size		RB	6 (full size)	
Note 1: If the UE reports in an available uplink reporting instance at subframe SF#n based on CQI estimation at a downlink subframe not later than SF#(n-4), this reported subband or wideband CQI cannot be applied at the eNB downlink before SF#(n+4) Note 2: Reference measurement channel RC.3 FDD according to Table A.4-1 with one/two sided dynamic OCNG Pattern OP.1/2 FDD as described in Annex A.5.1.1/2.				

Table 9.3.3.1.1-2 Minimum requirement (FDD)

	Test 1	Test 2
α [%]	60	60
γ	1.6	1.6
UE Category	≥ 1	≥ 1

9.3.3.1.2 TDD

For the parameters specified in Table 9.3.3.1.2-1, and using the downlink physical channels specified in Annex C.3.2, the minimum requirements are specified in Table 9.3.3.1.2-2 and by the following

- a sub-band differential CQI offset level of +2 shall be reported at least $\alpha\%$ for at least one of the sub-bands of full size at the channel edges;
- the ratio of the throughput obtained when transmitting on a randomly selected sub-band among the sub-bands with the highest differential CQI offset level the corresponding TBS and that obtained when transmitting the TBS indicated by the reported wideband CQI median on a randomly selected sub-band in set S shall be $\geq \gamma$;

The requirements only apply for sub-bands of full size and the random scheduling across the sub-bands is done by selecting a new sub-band in each TTI for FDD, each available downlink transmission instance for TDD. Sub-bands of a size smaller than full size are excluded from the test.

Table 9.3.3.1.2-1 Sub-band test for single antenna transmission (TDD)

Parameter	Unit	Test 1	Test 2
Bandwidth	MHz	10 MHz	10 MHz
Transmission mode		1 (port 0)	1 (port 0)
Downlink power allocation	ρ_A	dB	0
	ρ_B	dB	0
	σ	dB	0
Uplink downlink configuration		2	
Special subframe configuration		4	
$I_{ot}^{(j)}$ for RB 0...5	dB[mW/15kHz]	-102	-93
$I_{ot}^{(j)}$ for RB 6...41	dB[mW/15kHz]	-93	-93
$I_{ot}^{(j)}$ for RB 42...49	dB[mW/15kHz]	-93	-102
$\hat{I}_{or}^{(j)}$	dB[mW/15kHz]	-94	-94
Max number of HARQ transmissions		1	
Propagation channel		Clause B.2.4 with $\tau_d = 0.45 \mu s$, $a = 1$, $f_D = 5$ Hz	
Antenna configuration		1 x 2	
Reporting interval	ms	5	
CQI delay	ms	10 or 11	
Reporting mode		PUSCH 3-0	
Sub-band size	RB	6 (full size)	
ACK/NACK feedback mode		Multiplexing	
Note 1:	If the UE reports in an available uplink reporting instance at subframe SF#n based on CQI estimation at a downlink subframe not later than SF#(n-4), this reported subband or wideband CQI cannot be applied at the eNB downlink before SF#(n+4).		
Note 2:	Reference measurement channel RC.3 TDD according to table A.4-1 with one/two sided dynamic OCNG Pattern OP.1/2 TDD as described in Annex A.5.2.1/2.		

Table 9.3.3.1.2-2 Minimum requirement (TDD)

	Test 1	Test 2
α [%]	60	60
γ	1.6	1.6
UE Category	≥ 1	≥ 1

9.3.3.2 Void

9.3.3.2.1 Void

9.3.3.2.2 Void

9.3.4 UE-selected subband CQI

The accuracy of UE-selected subband channel quality indicator (CQI) reporting under frequency-selective fading conditions is determined by the relative increase of the throughput obtained when transmitting on the UE-selected subbands with the corresponding transport format compared to the case for which a fixed format is transmitted on any subband in set S of TS 36.213 [6]. The purpose is to verify that correct subbands are accurately reported for frequency-selective scheduling. To account for sensitivity of the input SNR the subband CQI reporting under frequency-selective fading conditions is considered to be verified if the reporting accuracy is met for at least one of two SNR levels separated by an offset of 1 dB.

9.3.4.1 Minimum requirement PUSCH 2-0 (Cell-Specific Reference Symbols)

9.3.4.1.1 FDD

For the parameters specified in Table 9.3.4.1.1-1, and using the downlink physical channels specified in Annex C.3.2, the minimum requirements are specified in Table 9.3.4.1.1-2 and by the following

- a) the ratio of the throughput obtained when transmitting on a randomly selected subband among the best M subbands reported by the UE the corresponding TBS and that obtained when transmitting the TBS indicated by the reported wideband CQI median on a randomly selected subband in set S shall be $\geq \gamma$;

The requirements only apply for subbands of full size and the random scheduling across the subbands is done by selecting a new subband in each TTI for FDD. The transport block size TBS (wideband CQI median) is that resulting from the code rate which is closest to that indicated by the wideband CQI median and the N_{PRB} entry in Table 7.1.7.2.1-1 of TS 36.213 [6] that corresponds to the subband size.

Table 9.3.4.1.1-1 Subband test for single antenna transmission (FDD)

Parameter		Unit	Test 1		Test 2	
Bandwidth		MHz	10 MHz			
Transmission mode			1 (port 0)			
Downlink power allocation	ρ_A	dB	0			
	ρ_B	dB	0			
	σ	dB	0			
SNR (Note 3)		dB	9	10	14	15
$\hat{I}_{or}^{(j)}$		dB[mW/15kHz]	-89	-88	-84	-83
$N_{oc}^{(j)}$		dB[mW/15kHz]	-98		-98	
Propagation channel			Clause B.2.4 with $\tau_d = 0.45 \mu\text{s}$, $a = 1$, $f_D = 5 \text{ Hz}$			
Reporting interval		ms	5			
CQI delay		ms	8			
Reporting mode			PUSCH 2-0			
Max number of HARQ transmissions			1			
Subband size (k)		RBs	3 (full size)			
Number of preferred subbands (M)			5			
<p>Note 1: If the UE reports in an available uplink reporting instance at subframe SF#n based on CQI estimation at a downlink subframe not later than SF#$(n-4)$, this reported subband or wideband CQI cannot be applied at the eNB downlink before SF#$(n+4)$</p> <p>Note 2: Reference measurement channel RC.5 FDD according to Table A.4-1 with one/two sided dynamic OCNG Pattern OP.1/2 FDD as described in Annex A.5.1.1/2.</p> <p>Note 3: For each test, the minimum requirements shall be fulfilled for at least one of the two SNR(s) and the respective wanted signal input level.</p>						

Table 9.3.4.1.1-2 Minimum requirement (FDD)

	Test 1	Test 2
γ	1.2	1.2
UE Category	≥ 1	≥ 1

9.3.4.1.2 TDD

For the parameters specified in Table 9.3.4.1.2-1, and using the downlink physical channels specified in Annex C.3.2, the minimum requirements are specified in Table 9.3.4.1.2-2 and by the following

- a) the ratio of the throughput obtained when transmitting on a randomly selected subband among the best M subbands reported by the UE the corresponding TBS and that obtained when transmitting the TBS indicated by the reported wideband CQI median on a randomly selected subband in set S shall be $\geq \gamma$;

The requirements only apply for subbands of full size and the random scheduling across the subbands is done by selecting a new subband in each available downlink transmission instance for TDD. The transport block size TBS (wideband CQI median) is that resulting from the code rate which is closest to that indicated by the wideband CQI median and the N_{PRB} entry in Table 7.1.7.2.1-1 of TS 36.213 [6] that corresponds to the subband size.

Table 9.3.4.1.2-1 Sub-band test for single antenna transmission (TDD)

Parameter		Unit	Test 1		Test 2	
Bandwidth		MHz	10 MHz			
Transmission mode			1 (port 0)			
Downlink power allocation	ρ_A	dB	0			
	ρ_B	dB	0			
	σ	dB	0			
Uplink downlink configuration			2			
Special subframe configuration			4			
SNR (Note 3)		dB	9	10	14	15
$\hat{I}_{or}^{(j)}$		dB[mW/15kHz]	-89	-88	-84	-83
$N_{oc}^{(j)}$		dB[mW/15kHz]	-98		-98	
Propagation channel			Clause B.2.4 with $\tau_d = 0.45 \mu\text{s}$, $a = 1$, $f_D = 5 \text{ Hz}$			
Reporting interval		ms	5			
CQI delay		ms	10 or 11			
Reporting mode			PUSCH 2-0			
Max number of HARQ transmissions			1			
Subband size (k)		RBs	3 (full size)			
Number of preferred subbands (M)			5			
ACK/NACK feedback mode			Multiplexing			
<p>Note 1: If the UE reports in an available uplink reporting instance at subframe SF#n based on CQI estimation at a downlink subframe not later than SF#(n-4), this reported subband or wideband CQI cannot be applied at the eNB downlink before SF#(n+4)</p> <p>Note 2: Reference measurement channel RC.5 TDD according to Table A.4-1 with one/two sided dynamic OCNG Pattern OP.1/2 TDD as described in Annex A.5.2.1/2.</p> <p>Note 3: For each test, the minimum requirements shall be fulfilled for at least one of the two SNR(s) and the respective wanted signal input level.</p>						

Table 9.3.4.1.2-2 Minimum requirement (TDD)

	Test 1	Test 2
γ	1.2	1.2
UE Category	≥ 1	≥ 1

9.3.4.2 Minimum requirement PUCCH 2-0 (Cell-Specific Reference Symbols)

9.3.4.2.1 FDD

For the parameters specified in Table 9.3.4.2.1-1, and using the downlink physical channels specified in Annex C.3.2, the minimum requirements are specified in Table 9.3.4.2.1-2 and by the following

- a) the ratio of the throughput obtained when transmitting on subbands reported by the UE the corresponding TBS and that obtained when transmitting the TBS indicated by the reported wideband CQI median on a randomly selected subband in set S shall be $\geq \gamma$;

The requirements only apply for subbands of full size and the random scheduling across the subbands is done by selecting a new subband in each TTI for FDD. The transport block size TBS (wideband CQI median) is that resulting

from the code rate which is closest to that indicated by the wideband CQI median and the N_{PRB} entry in Table 7.1.7.2.1-1 of TS 36.213 [6] that corresponds to the subband size.

Table 9.3.4.2.1-1 Subband test for single antenna transmission (FDD)

Parameter	Unit	Test 1		Test 2	
Bandwidth	MHz	10 MHz			
Transmission mode		1 (port 0)			
Downlink power allocation	ρ_A	dB			
	ρ_B	dB			
	σ	dB			
SNR (Note 3)	dB	8	9	13	14
$\hat{I}_{or}^{(j)}$	dB[mW/15kHz]	-90	-89	-85	-84
$N_{oc}^{(j)}$	dB[mW/15kHz]	-98		-98	
Propagation channel		Clause B.2.4 with $\tau_d = 0.45 \mu\text{s}$, $a = 1$, $f_D = 5 \text{ Hz}$			
Reporting periodicity	ms	$N_P = 2$			
CQI delay	ms	8			
Physical channel for CQI reporting		PUSCH (Note 4)			
PUCCH Report Type for wideband CQI		4			
PUCCH Report Type for subband CQI		1			
Max number of HARQ transmissions		1			
Subband size (k)	RBs	6 (full size)			
Number of bandwidth parts (J)		3			
K		1			
<i>cqi-pmi-ConfigIndex</i>		1			
Note 1:	If the UE reports in an available uplink reporting instance at subframe SF# n based on CQI estimation at a downlink subframe not later than SF#($n-4$), this reported subband or wideband CQI cannot be applied at the eNB downlink before SF#($n+4$)				
Note 2:	Reference measurement channel RC.3 FDD according to Table A.4-1 with one/two sided dynamic OCNG Pattern OP.1/2 FDD as described in Annex A.5.1.1/2.				
Note 3:	For each test, the minimum requirements shall be fulfilled for at least one of the two SNR(s) and the respective wanted signal input level.				
Note 4:	To avoid collisions between CQI reports and HARQ-ACK it is necessary to report both on PUSCH instead of PUCCH. PDCCH DCI format 0 shall be transmitted in downlink SF#1, #3, #7 and #9 to allow periodic CQI to multiplex with the HARQ-ACK on PUSCH in uplink subframe SF#5, #7, #1 and #3.				
Note 5:	CQI reports for the short subband (having 2RBs in the last bandwidth part) are to be disregarded and data scheduling according to the most recent subband CQI report for bandwidth part with $j=1$.				
Note 6:	In the case where wideband CQI is reported, data is to be scheduled according to the most recently used subband CQI report.				

Table 9.3.4.2.1-2 Minimum requirement (FDD)

	Test 1	Test 2
γ	1.15	1.15
UE Category	≥ 1	≥ 1

9.3.4.2.2 TDD

For the parameters specified in Table 9.3.4.2.2-1, and using the downlink physical channels specified in Annex C.3.2, the minimum requirements are specified in Table 9.3.4.2.2-2 and by the following

a) the ratio of the throughput obtained when transmitting on subbands reported by the UE the corresponding TBS and that obtained when transmitting the TBS indicated by the reported wideband CQI median on a randomly selected subband in set S shall be $\geq \gamma$;

The requirements only apply for subbands of full size and the random scheduling across the subbands is done by selecting a new subband in each available downlink transmission instance for TDD. The transport block size TBS (wideband CQI median) is that resulting from the code rate which is closest to that indicated by the wideband CQI median and the N_{PRB} entry in Table 7.1.7.2.1-1 of TS 36.213 [6] that corresponds to the subband size.

Table 9.3.4.2.2-1 Sub-band test for single antenna transmission (TDD)

Parameter		Unit	Test 1		Test 2	
Bandwidth		MHz	10 MHz			
Transmission mode			1 (port 0)			
Downlink power allocation	ρ_A	dB	0			
	ρ_B	dB	0			
	σ	dB	0			
Uplink downlink configuration			2			
Special subframe configuration			4			
SNR (Note 3)		dB	8	9	13	14
$\hat{I}_{or}^{(j)}$		dB[mW/15kHz]	-90	-89	-85	-84
$N_{oc}^{(j)}$		dB[mW/15kHz]	-98		-98	
Propagation channel			Clause B.2.4 with $\tau_d = 0.45 \mu\text{s}$, $a = 1$, $f_D = 5 \text{ Hz}$			
Reporting periodicity		ms	$N_p = 5$			
CQI delay		ms	10 or 11			
Physical channel for CQI reporting			PUSCH (Note 4)			
PUCCH Report Type for wideband CQI			4			
PUCCH Report Type for subband CQI			1			
Max number of HARQ transmissions			1			
Subband size (k)		RBs	6 (full size)			
Number of bandwidth parts (J)			3			
K			1			
$cqi-pmi-ConfigIndex$			3			
ACK/NACK feedback mode			Multiplexing			
<p>Note 1: If the UE reports in an available uplink reporting instance at subframe SF#n based on CQI estimation at a downlink subframe not later than SF#$(n-4)$, this reported subband or wideband CQI cannot be applied at the eNB downlink before SF#$(n+4)$.</p> <p>Note 2: Reference measurement channel RC.3 TDD according to Table A.4-1 with one/two sided dynamic OCNG Pattern OP.1/2 TDD as described in Annex A.5.2.1/2.</p> <p>Note 3: For each test, the minimum requirements shall be fulfilled for at least one of the two SNR(s) and the respective wanted signal input level.</p> <p>Note 4: To avoid collisions between CQI reports and HARQ-ACK it is necessary to report both on PUSCH instead of PUCCH. PDCCH DCI format 0 shall be transmitted in downlink SF#3 and #8 to allow periodic CQI to multiplex with the HARQ-ACK on PUSCH in uplink subframe SF#7 and #2.</p> <p>Note 5: CQI reports for the short subband (having 2RBs in the last bandwidth part) are to be disregarded and data scheduling according to the most recent subband CQI report for bandwidth part with $j=1$.</p> <p>Note 6: In the case where wideband CQI is reported, data is to be scheduled according to the most recently used subband CQI report.</p>						

Table 9.3.4.2.2-2 Minimum requirement (TDD)

	Test 1	Test 2
γ	1.15	1.15
UE Category	≥ 1	≥ 1

9.3.5 Additional requirements for enhanced receiver Type A

The purpose of the test is to verify that the reporting of the channel quality is based on the receiver of the enhanced Type A. Performance requirements are specified in terms of the relative increase of the throughput obtained when the transport format is that indicated by the reported CQI subject to an interference model compared to the case with a white Gaussian noise model, and a requirement on the minimum BLER of the transmitted transport formats indicated by the reported CQI subject to an interference model.

9.3.5.1 Minimum requirement PUCCH 1-0 (Cell-Specific Reference Symbol)

9.3.5.1.1 FDD

For the parameters specified in Table 9.3.5.1.1-1, and using the downlink physical channels specified in Annex C, the minimum requirements are specified in Table 9.3.5.1.1-2 and by the following

- a) the ratio of the throughput obtained when transmitting the transport format indicated by each reported wideband CQI index subject to an interference source with specified DIP and that obtained when transmitting the transport format indicated by each reported wideband CQI index subject to a white Gaussian noise source shall be $\geq \gamma$;
- b) when transmitting the transport format indicated by each reported wideband CQI index subject to an interference source with specified DIP, the average BLER for the indicated transport formats shall be greater than or equal to 2%.

Table 9.3.5.1.1-1 Fading test for single antenna (FDD)

Parameter	Unit	Cell 1	Cell 2
Bandwidth	MHz	10 MHz	
Transmission mode		1 (port 0)	
Cyclic Prefix		Normal	Normal
Cell ID		0	1
SINR (Note 8)	dB	-2	N/A
$N_{oc}^{(j)}$	dB[mW/15kHz]	-98	N/A
Propagation channel		EPA5	Static (Note 7)
Correlation and antenna configuration		Low (1 x 2)	(1 x 2)
DIP (Note 4)	dB	N/A	-0.41
Reference measurement channel		Note 2	R.2 FDD
Reporting mode		PUCCH 1-0	N/A
Reporting periodicity	ms	$N_{pd} = 2$	N/A
CQI delay	ms	8	N/A
Physical channel for CQI reporting		PUSCH (Note 3)	N/A
PUCCH Report Type		4	N/A
<i>cqi-pmi-ConfigurationIndex</i>		1	N/A
Max number of HARQ transmissions		1	N/A
<p>Note 1: If the UE reports in an available uplink reporting instance at subframe SF#n based on CQI estimation at a downlink SF not later than SF#(n-4), this reported wideband CQI cannot be applied at the eNB downlink before SF#(n+4)</p> <p>Note 2: Reference measurement channel RC.1 FDD according to Table A.4-1 for Category 2-8 with one sided dynamic OCNG Pattern OP.1 FDD as described in Annex A.5.1.1 and RC.4 FDD according to Table A.4-1 for Category 1 with one/two sided dynamic OCNG Pattern OP.1/2 FDD as described in Annex A.5.1.1/2.</p> <p>Note 3: To avoid collisions between CQI reports and HARQ-ACK it is necessary to report both on PUSCH instead of PUCCH. PDCCH DCI format 0 shall be transmitted in downlink SF#1, #3, #7 and #9 to allow periodic CQI to multiplex with the HARQ-ACK on PUSCH in uplink subframe SF#5, #7, #1 and #3.</p> <p>Note 4: The respective received power spectral density of each interfering cell relative to N_{oc} is defined by its associated DIP value as specified in clause B.5.1.</p> <p>Note 5: Two cells are considered in which Cell 1 is the serving cell and Cell 2 is the interfering cell. The number of the CRS ports in both cells is the same. Interfering cell is fully loaded.</p> <p>Note 6: Both cells are time-synchronous.</p> <p>Note 7: Static channel is used for the interference model. In case for white Gaussian noise model Cell 2 is not present.</p> <p>Note 8: SINR corresponds to \hat{E}_s / N_{oc} of Cell 1 as defined in clause 8.1.1.</p>			

Table 9.3.5.1.1-2 Minimum requirement (FDD)

γ	1.8
UE Category	≥ 1

9.3.5.1.2 TDD

For the parameters specified in Table 9.3.5.1.2-1, and using the downlink physical channels specified in Annex C, the minimum requirements are specified in 9.3.5.1.2-2 and by the following

- a) the ratio of the throughput obtained when transmitting the transport format indicated by each reported wideband CQI index subject to an interference source with specified DIP and that obtained when transmitting the transport format indicated by each reported wideband CQI index subject to a white Gaussian noise source shall be $\geq \gamma$;
- b) when transmitting the transport format indicated by each reported wideband CQI index subject to an interference source with specified DIP, the average BLER for the indicated transport formats shall be greater than or equal to 2%.

Table 9.3.5.1.2-1 Fading test for single antenna (TDD)

Parameter	Unit	Cell 1	Cell 2
Bandwidth	MHz	10 MHz	
Transmission mode		1 (port 0)	
Uplink downlink configuration		2	
Special subframe configuration		4	
Cyclic Prefix		Normal	Normal
Cell ID		0	1
SINR (Note 8)	dB	-2	N/A
$N_{oc}^{(j)}$	dB[mW/15kHz]	-98	-98
Propagation channel		EPA5	Static (Note 7)
Correlation and antenna configuration		Low (1 x 2)	(1 x 2)
DIP (Note 4)	dB	N/A	-0.41
Reference measurement channel		Note 2	R.2A TDD
Reporting mode		PUCCH 1-0	N/A
Reporting periodicity	ms	$N_{pd} = 5$	N/A
CQI delay	ms	10 or 11	N/A
Physical channel for CQI reporting		PUSCH (Note 3)	N/A
PUCCH Report Type		4	N/A
<i>cqi-pmi-ConfigurationIndex</i>		3	N/A
Max number of HARQ transmissions		1	N/A
ACK/NACK feedback mode		Multiplexing	N/A
<p>Note 1: If the UE reports in an available uplink reporting instance at subframe SF#n based on CQI estimation at a downlink SF not later than SF#(n-4), this reported wideband CQI cannot be applied at the eNB downlink before SF#(n+4)</p> <p>Note 2: Reference measurement channel RC.1 TDD according to Table A.4-1 for Category 2-8 with one sided dynamic OCNG Pattern OP.1 TDD as described in Annex A.5.2.1 and RC.4 TDD according to Table A.4-1 for Category 1 with one/two sided dynamic OCNG Pattern OP.1/2 TDD as described in Annex A.5.2.1/2.</p> <p>Note 3: To avoid collisions between CQI reports and HARQ-ACK it is necessary to report both on PUSCH instead of PUCCH. PDCCH DCI format 0 shall be transmitted in downlink SF#3 and #8 to allow periodic CQI to multiplex with the HARQ-ACK on PUSCH in uplink subframe SF#7 and #2.</p> <p>Note 4: The respective received power spectral density of each interfering cell relative to N_{oc} is defined by its associated DIP value as specified in clause B.5.1.</p> <p>Note 5: Two cells are considered in which Cell 1 is the serving cell and Cell 2 is the interfering cell. The number of the CRS ports in both cells is the same. Interfering cell is fully loaded.</p> <p>Note 6: Both cells are time-synchronous.</p> <p>Note 7: Static channel is used for the interference model. In case for white Gaussian noise model Cell 2 is not present.</p> <p>Note 8: SINR corresponds to \hat{E}_s / N_{oc} of Cell 1 as defined in clause 8.1.1.</p>			

Table 9.3.5.1.2-2 Minimum requirement (TDD)

γ	1.8
UE Category	≥ 1

9.3.5.2 Minimum requirement PUCCH 1-1 (CSI Reference Symbol)

9.3.5.2.1 FDD

For the parameters specified in Table 9.3.5.2.1-1, and using the downlink physical channels specified in Annex C, the minimum requirements are specified in Table 9.3.5.2.1-2 and by the following

- a) the ratio of the throughput obtained when transmitting the transport format indicated by each reported wideband CQI index subject to an interference source with specified DIP and that obtained when transmitting the transport format indicated by each reported wideband CQI index subject to a white Gaussian noise source shall be $\geq \gamma$;
- b) when transmitting the transport format indicated by each reported wideband CQI index subject to an interference source with specified DIP, the average BLER for the indicated transport formats shall be greater than or equal to 2%.

Table 9.3.5.2.1-1 Fading test for two antennas (FDD)

Parameter	Unit	Cell 1	Cell 2
Bandwidth	MHz	10 MHz	
Transmission mode		9	
Cyclic Prefix		Normal	Normal
Cell ID		0	1
SINR (Note 8)	dB	-2	N/A
$N_{oc}^{(j)}$	dB[mW/15kHz]	-98	N/A
Propagation channel		EPA5	Static (Note 7)
Correlation and antenna configuration		Low (2 x 2)	(1 x 2)
Beamforming Model		As specified in Section B.4.3 (Note 10, 11)	N/A
DIP (Note 4)	dB	N/A	-0.41
Cell-specific reference signals		Antenna ports 0,1	Antenna port 0
CSI reference signals		Antenna ports 15,16	N/A
CSI-RS periodicity and subframe offset		5/1	N/A
CSI-RS reference signal configuration		2	N/A
Zero-power CSI-RS configuration I_{CSI-RS} / ZeroPowerCSI-RS bitmap	Subframes / bitmap	N/A	1 / 001000000000 000
CodeBookSubsetRestriction bitmap		001111	N/A
Reference measurement channel		Note 2	R.2 FDD
Reporting mode		PUCCH 1-1	N/A
Reporting periodicity	ms	$N_{pd} = 5$	N/A
CQI delay	ms	8	N/A
Physical channel for CQI/PMI reporting		PUSCH (Note 3)	N/A
PUCCH Report Type for CQI/PMI		2	N/A
PUCCH channel for RI reporting		PUCCH Format 2	N/A
PUCCH Report Type for RI		3	N/A
$cqi-pmi-ConfigurationIndex$		2	N/A
$ri-ConfigIndex$		1	N/A
Max number of HARQ transmissions		1	N/A
Note 1:	If the UE reports in an available uplink reporting instance at subframe SF#n based on CQI estimation at a downlink SF not later than SF#(n-4), this reported wideband CQI cannot be applied at the eNB downlink before SF#(n+4)		
Note 2:	Reference measurement channel RC.11 FDD according to Table A.4-1 with one sided dynamic OCN Pattern OP.1 FDD as described in Annex A.5.1.1.		
Note 3:	To avoid collisions between CQI/ PMI reports and HARQ-ACK it is necessary to report both on PUSCH instead of PUCCH. PDCCH DCI format 0 shall be transmitted in downlink SF#1 and #6 to allow periodic CQI/ PMI to multiplex with the HARQ-ACK on PUSCH in uplink subframe SF#0 and #5.		
Note 4:	The respective received power spectral density of each interfering cell relative to N_{oc} is defined by its associated DIP value as specified in clause B.5.1.		
Note 5:	Two cells are considered in which Cell 1 is the serving cell and Cell 2 is the interfering cell. Interfering cell is fully loaded.		

Note 6:	Both cells are time-synchronous.
Note 7:	Static channel is used for the interference model. In case for white Gaussian noise model Cell 2 is not present.
Note 8:	SINR corresponds to \widehat{E}_s / N_{oc} of Cell 1 as defined in clause 8.1.1.
Note 9:	N/A
Note 10:	The precoder in clause B.4.3 follows UE recommended PMI.
Note 11:	If the UE reports in an available uplink reporting instance at subframe SF#n based on PMI estimation at a downlink SF not later than SF#(n-4), this reported PMI cannot be applied at the eNB downlink before SF#(n+4).

Table 9.3.5.2.1-2 Minimum requirement (FDD)

γ	1.8
UE Category	≥ 2

9.3.5.2.2 TDD

For the parameters specified in Table 9.3.5.2.2-1, and using the downlink physical channels specified in Annex C, the minimum requirements are specified in 9.3.5.2.2-2 and by the following

- a) the ratio of the throughput obtained when transmitting the transport format indicated by each reported wideband CQI index subject to an interference source with specified DIP and that obtained when transmitting the transport format indicated by each reported wideband CQI index subject to a white Gaussian noise source shall be $\geq \gamma$;
- b) when transmitting the transport format indicated by each reported wideband CQI index subject to an interference source with specified DIP, the average BLER for the indicated transport formats shall be greater than or equal to 2%.

Table 9.3.5.2.2-1: Fading test for single antenna (TDD)

Parameter	Unit	Cell 1	Cell 2
Bandwidth	MHz	10 MHz	
Transmission mode		9	
Uplink downlink configuration		2	
Special subframe configuration		4	
Cyclic Prefix		Normal	Normal
Cell ID		0	1
SINR (Note 8)	dB	-2	N/A
$N_{oc}^{(j)}$	dB[mW/15kHz]	-98	-98
Propagation channel		EPA5	Static (Note 7)
Correlation and antenna configuration		Low (2 x 2)	(1 x 2)
Beamforming Model		As specified in Section B.4.3 (Note 11, 12)	N/A
DIP (Note 4)	dB	N/A	-0.41
Cell-specific reference signals		Antenna ports 0,1	Antenna port 0
CSI reference signals		Antenna ports 15,16	N/A
CSI-RS periodicity and subframe offset		5/3	N/A
CSI-RS reference signal configuration		2	N/A
Zero-power CSI-RS configuration I_{CSI-RS} / <i>ZeroPowerCSI-RS</i> bitmap	Subframes / bitmap	N/A	3 / 001000000000 0000
CodeBookSubsetRestriction bitmap		001111	N/A
Reference measurement channel		Note 2	R.2A TDD
Reporting mode		PUCCH 1-1	N/A
Reporting periodicity	ms	$N_{pd} = 5$	N/A
CQI delay	ms	10	N/A
Physical channel for CQI/PMI reporting		PUSCH (Note 3)	N/A
PUCCH Report Type for CQI/PMI		2	N/A
Physical channel for RI reporting		PUCCH Format 2	N/A
PUCCH Report Type for RI		3	N/A
<i>cqi-pmi-ConfigurationIndex</i>		3	N/A
<i>ri-ConfigIndex</i>		805 (Note 9)	N/A
Max number of HARQ transmissions		1	N/A
ACK/NACK feedback mode		Multiplexing	N/A
<p>Note 1: If the UE reports in an available uplink reporting instance at subframe SF#n based on CQI estimation at a downlink SF not later than SF#(n-4), this reported wideband CQI cannot be applied at the eNB downlink before SF#(n+4)</p> <p>Note 2: Reference measurement channel RC.11 TDD according to Table A.4-1 with one sided dynamic OCNG Pattern OP.1 TDD as described in Annex A.5.2.1.</p> <p>Note 3: To avoid collisions between CQI/ PMI reports and HARQ-ACK it is necessary to report both on PUSCH instead of PUCCH. PDCCH DCI format 0 shall be transmitted in downlink SF#3 and #8 to allow periodic CQI/ PMI to multiplex with the HARQ-ACK on PUSCH in</p>			

Note 4:	uplink subframe SF#2 and #7. The respective received power spectral density of each interfering cell relative to N_{oc} is defined by its associated DIP value as specified in clause B.5.1.
Note 5:	Two cells are considered in which Cell 1 is the serving cell and Cell 2 is the interfering cell. Interfering cell is fully loaded.
Note 6:	Both cells are time-synchronous.
Note 7:	Static channel is used for the interference model. In case for white Gaussian noise model Cell 2 is not present.
Note 8:	SINR corresponds to \hat{E}_s / N_{oc} of Cell 1 as defined in clause 8.1.1.
Note 9:	RI reporting interval is set to the maximum allowable length of 160ms to minimise collisions between RI, CQI/PMI and HARQ-ACK reports. In the case when all three reports collide, it is expected that CQI/PMI reports will be dropped, while RI and HARQ-ACK will be multiplexed. At eNB, CQI report collection shall be skipped every 160ms during performance verification and the reported CQI in subframe SF#7 of the previous frame is applied in downlink subframes until a new CQI (after CQI/PMI dropping) is available.
Note 10:	N/A.
Note 11:	The precoder in clause B.4.3 follows UE recommended PMI.
Note 12:	If the UE reports in an available uplink reporting instance at subframe SF#n based on PMI estimation at a downlink SF not later than SF#(n-4), this reported PMI cannot be applied at the eNB downlink before SF#(n+4).

Table 9.3.5.2-2 Minimum requirement (TDD)

γ	1.8
UE Category	≥ 2

9.3.6 Minimum requirement (With multiple CSI processes)

The purpose of the test is to verify the reporting accuracy of the CQI and the UE processing capability for multiple CSI processes. Each CSI process is associated with a CSI-RS resource and a CSI-IM resource as shown in Table 9.3.6-1. For UE supports one CSI process, CSI process 2 is configured and the corresponding requirements shall be fulfilled. For UE supports three CSI processes, CSI processes 0, 1 and 2 are configured and the corresponding requirements shall be fulfilled. For UE supports four CSI processes, CSI processes 0, 1, 2 and 3 are configured and the corresponding requirements shall be fulfilled.

Table 9.3.6-1: Configuration of CSI processes

	CSI process 0	CSI process 1	CSI process 2	CSI process 3
CSI-RS resource	CSI-RS signal 0	CSI-RS signal 1	CSI-RS signal 0	CSI-RS signal 1
CSI-IM resource	CSI-IM resource 0	CSI-IM resource 0	CSI-IM resource 1	CSI-IM resource 2

9.3.6.1 FDD

For the parameters specified in Table 9.3.6.1-1, and using the downlink physical channels specified in Annex C.3.2, the minimum requirements are specified in Table 9.3.6.1-2 and by the following

- a sub-band differential CQI offset level of 0 shall be reported at least $\alpha\%$ of the time but less than $\beta\%$ for each sub-band for CSI process 1, 2, or 3;
- a CQI index not in the set {median CQI -1, median CQI, median CQI +1} shall be reported at least $\delta\%$ of the time for CSI process 0;
- the difference of the median CQIs of the reported wideband CQI for configured CSI processes shall be greater or equal to the values as in Table 9.3.6.1-3;

- d) the ratio of the throughput obtained when transmitting on a randomly selected sub-band among the sub-bands with the highest differential CQI offset level the corresponding TBS and that obtained when transmitting the TBS indicated by the reported wideband CQI median on a randomly selected sub-band in set S shall be $\geq \gamma$;
- e) when transmitting on a randomly selected sub-band among the sub-bands with the highest differential CQI offset level the corresponding TBS, the average BLER for the indicated transport formats shall be greater or equal to 0.02.

The requirements only apply for sub-bands of full size and the random scheduling across the sub-bands is done by selecting a new sub-band in each TTI for FDD, each available downlink transmission instance for TDD. Sub-bands of a size smaller than full size are excluded from the test.

Table 9.3.6.1-1: Fading test for FDD

Parameter	Unit	Test 1				Test 2			
		TP1		TP2		TP1		TP2	
Bandwidth	MHz	10 MHz				10 MHz			
Transmission mode		10		10		10		10	
Downlink power allocation	ρ_A	0				0			
	ρ_B	0				0			
	P_c	-3		0		-3		0	
	σ	-3				-3			
SNR (Note 7)	dB	10	11	7	8	14	15	9	10
$\hat{I}_{or}^{(j)}$	dB[mW/15kHz]	-88	-87	-91	-90	-84	-85	-89	-88
$N_{oc}^{(j)}$	dB[mW/15kHz]	-98				-98			
Propagation channel		EPA 5 Low		Clause B.2.4.1 with $\tau_d = 0.45 \mu\text{s}$, $a = 1$, $f_D = 5 \text{ Hz}$		EPA 5 Low		Clause B.2.4.1 with $\tau_d = 0.45 \mu\text{s}$, $a = 1$, $f_D = 5 \text{ Hz}$	
Antenna configuration		4x2		2x2		4x2		2x2	
Beamforming Model		As specified in Section B.4.3				As specified in Section B.4.3			
Timing offset between TPs	us	0				0			
Frequency offset between TPs	Hz	0				0			
Cell-specific reference signals		Antenna ports 0,1				Antenna ports 0,1			
CSI-RS signal 0		Antenna ports 15,...,18		N/A		Antenna ports 15,...,18		N/A	
CSI-RS 0 periodicity and subframe offset $T_{\text{CSI-RS}} / \Delta_{\text{CSI-RS}}$		5/1		N/A		5/1		N/A	
CSI-RS 0 configuration		0		N/A		0		N/A	
CSI-RS signal 1		N/A		Antenna ports 15,16		N/A		Antenna ports 15,16	
CSI-RS 1 periodicity and subframe offset $T_{\text{CSI-RS}} / \Delta_{\text{CSI-RS}}$		N/A		5/1		N/A		5/1	
CSI-RS 1 configuration		N/A		5		N/A		5	
Zero-power CSI-RS 0 configuration $I_{\text{CSI-RS}} / \text{ZeroPowerCSI-RS}$ bitmap		N/A		1 / 111000000000 0000		N/A		1 / 111000000000 0000	
Zero-power CSI-RS 1 configuration $I_{\text{CSI-RS}} / \text{ZeroPowerCSI-RS}$ bitmap		1 / 00100110000 00000		N/A		1 / 00100110000 00000		N/A	
CSI-IM 0 periodicity and subframe offset $T_{\text{CSI-IM}} / \Delta_{\text{CSI-IM}}$		5/1		5/1		5/1		5/1	
CSI-IM 0 configuration		2		2		2		2	
CSI-IM 1 periodicity and subframe offset $T_{\text{CSI-IM}} / \Delta_{\text{CSI-IM}}$		5/1		N/A		5/1		N/A	
CSI-IM 1 configuration		6		N/A		6		N/A	
CSI-IM 2 periodicity and subframe offset $T_{\text{CSI-IM}} / \Delta_{\text{CSI-IM}}$		N/A		5/1		N/A		5/1	
CSI-IM 2 configuration		N/A		1		N/A		1	
CSI process 0	CSI-RS	CSI-RS 0				CSI-RS 0			
	CSI-IM	CSI-IM 0				CSI-IM 0			
	Reporting mode	PUCCH 1-1				PUCCH 1-1			
	CodeBookSubsetRestriction bitmap	0x0000 0000 0000 0001				0x0000 0000 0000 0001			
	Reporting periodicity	ms		$N_{pd} = 5$		ms		$N_{pd} = 5$	
	CQI delay	ms		11		ms		11	
	Physical channel for CQI/ PMI reporting	PUSCH (Note 6)				PUSCH (Note 6)			
	PUCCH Report Type for CQI/PMI	2				2			
	PUCCH channel	PUCCH Format 2				PUCCH Format 2			

	for RI reporting					
	PUCCH report type for RI		3		3	
	<i>cqi-pmi-ConfigurationIndex</i>		4		4	
	<i>ri-ConfigIndex</i>		2		2	
CSI process 1	CSI-RS		CSI-RS 1		CSI-RS 1	
	CSI-IM		CSI-IM 0		CSI-IM 0	
	Reporting mode		PUSCH 3-1		PUSCH 3-1	
	CodeBookSubsetRestriction bitmap		000001		000001	
	Reporting interval (Note 10)	ms	5		5	
	CQI delay	ms	11		11	
	Sub-band size	RB	6 (full size)		6 (full size)	
CSI process 2 (For UE configured single process)	CSI-RS		CSI-RS 0		CSI-RS 0	
	CSI-IM		CSI-IM 1		CSI-IM 1	
	Reporting mode		PUSCH 3-1		PUSCH 3-1	
	CodeBookSubsetRestriction bitmap		0x0000 0000 0000 0001		0x0000 0000 0000 0001	
	Reporting interval (Note 8)	ms	5		5	
	CQI delay	ms	8		8	
	Sub-band size	RB	6 (full size) (Note 9)		6 (full size) (Note 9)	
CSI process 2 (For UE configured multiple processes)	CSI-RS		CSI-RS 0		CSI-RS 0	
	CSI-IM		CSI-IM 1		CSI-IM 1	
	Reporting mode		PUSCH 3-1		PUSCH 3-1	
	CodeBookSubsetRestriction bitmap		0x0000 0000 0000 0001		0x0000 0000 0000 0001	
	Reporting interval (Note 10)	ms	5		5	
	CQI delay	ms	11		11	
	Sub-band size	RB	6 (full size) (Note 9)		6 (full size) (Note 9)	
CSI process 3	CSI-RS		CSI-RS 1		CSI-RS 1	
	CSI-IM		CSI-IM 2		CSI-IM 2	
	Reporting mode		PUSCH 3-1		PUSCH 3-1	
	CodeBookSubsetRestriction bitmap		000001		000001	
	Reporting interval (Note 10)	ms	5		5	
	CQI delay	ms	11		11	
	Sub-band size	RB	6 (full size)		6 (full size)	
CSI process for PDSCH scheduling			CSI process 2		CSI process 2	
Cell ID			0	6	0	6
Quasi-co-located CSI-RS			CSI-RS 0	CSI-RS 1	CSI-RS 0	CSI-RS 1
Quasi-co-located CRS			Same Cell ID as Cell 1	Same Cell ID as Cell 2	Same Cell ID as Cell 1	Same Cell ID as Cell 2
PMI for subframe 2, 3, 4, 7, 8 and 9			0x0000 0000 0000 0001	100000	0x0000 0000 0000 0001	100000
PMI for subframe 1 and 6			0x0000 0000 0001 0000	100000	0x0000 0000 0001 0000	100000
Max number of HARQ transmissions			1	N/A	1	N/A
<p>Note 1: If the UE reports in an available uplink reporting instance at subframe SF#n based on CQI estimation at a downlink SF not later than SF#(n-4), this reported wideband CQI cannot be applied at the eNB downlink before SF#(n+4)</p> <p>Note 2: 3 symbols allocated to PDCCH</p> <p>Note 3: Reference measurement channel RC.12 FDD according to Table A.4-1. PDSCH transmission is scheduled on subframe 2, 3, 4, 7, 8 and 9 from TP1.</p> <p>Note 4: TM10 OCNG OP.8 FDD as specified in A.5.1.8 is transmitted on subframe 1 and 6 from TP1.</p> <p>Note 5: TM10 OCNG OP.8 FDD as specified in A.5.1.8 is transmitted on subframe 1, 2, 3, 4, 6, 7, 8 and 9 from TP2</p> <p>Note 6: To avoid collisions between CQI/PMI reports and HARQ-ACK it is necessary to report both on PUSCH instead of PUCCH. PDCCH DCI format 0 shall be transmitted in downlink SF#3 and #8 to allow periodic CQI/PMI to multiplex with the HARQ-ACK on PUSCH in uplink SF#2 and #7.</p> <p>Note 7: For each test, the minimum requirements shall be fulfilled for at least one of the two SNR(s) and the respective wanted signal input level.</p> <p>Note 8: PDCCH DCI format 0 with a trigger for aperiodic CQI shall be transmitted in downlink SF#1 and #6 to allow aperiodic CQI/PMI/RI to be transmitted in uplink SF#0 and #5.</p> <p>Note 9: For these sub-bands which are not selected for PDSCH transmission, TM10 OCNG should be transmitted.</p>						

Note 10: PDCCH DCI format 0 with a trigger for aperiodic CQI shall be transmitted in downlink SF#2 and #7 to allow aperiodic CQI/PMI/RI to be transmitted in uplink SF#1 and #6.

Table 9.3.6.1-2: Minimum requirement (FDD)

	CSI process 0	CSI process 1	CSI process 2	CSI process 3
α [%]	N/A	2	2	2
β [%]	N/A	40	40	40
δ [%]	10	N/A	N/A	N/A
γ	N/A	N/A	1.02	N/A
UE Category	≥ 1			

Table 9.3.6.1-3: Minimum median CQI difference between configured CSI processes (FDD)

	CSI process 1	CSI process 2	CSI process 3
CSI process 0	N/A	1	3
UE Category	≥ 1		

9.3.6.2 TDD

For the parameters specified in Table 9.3.6.2-1, and using the downlink physical channels specified in Annex C.3.2, the minimum requirements are specified in Table 9.3.6.2-2 and by the following

- a) a sub-band differential CQI offset level of 0 shall be reported at least α % of the time but less than β % for each sub-band for CSI process 1, 2, or 3;
- b) a CQI index not in the set {median CQI -1, median CQI, median CQI +1} shall be reported at least δ % of the time for CSI process 0;
- c) the difference of the median CQIs of the reported wideband CQI for configured CSI processes shall be greater or equal to the values as in Table 9.3.6.2-3;
- d) the ratio of the throughput obtained when transmitting on a randomly selected sub-band among the sub-bands with the highest differential CQI offset level the corresponding TBS and that obtained when transmitting the TBS indicated by the reported wideband CQI median on a randomly selected sub-band in set S shall be $\geq \gamma$;
- e) when transmitting on a randomly selected sub-band among the sub-bands with the highest differential CQI offset level the corresponding TBS, the average BLER for the indicated transport formats shall be greater or equal to 0.02.

The requirements only apply for sub-bands of full size and the random scheduling across the sub-bands is done by selecting a new sub-band in each TTI for FDD, each available downlink transmission instance for TDD. Sub-bands of a size smaller than full size are excluded from the test.

Table 9.3.6.2-1: Fading test for TDD

Parameter		Unit	Test 1				Test 2			
			TP1		TP2		TP1		TP2	
Bandwidth		MHz	10 MHz				10 MHz			
Transmission mode			10		10		10		10	
Uplink downlink configuration			2		2		2		2	
Special subframe configuration			4		4		4		4	
Downlink power allocation	ρ_A	dB	0				0			
	ρ_B	dB	0				0			
	P_C	dB	-3		0		-3		0	
	σ	dB	-3				-3			
SNR (Note 7)		dB	10	11	7	8	14	15	9	10
$\hat{I}_{or}^{(j)}$		dB[mW/15kHz]	-88	-87	-91	-90	-84	-85	-89	-88
$N_{oc}^{(j)}$		dB[mW/15kHz]	-98				-98			
Propagation channel			EPA 5 Low		Clause B.2.4.1 with $\tau_d = 0.45 \mu s$, $a = 1$, $f_D = 5 \text{ Hz}$		EPA 5 Low		Clause B.2.4.1 with $\tau_d = 0.45 \mu s$, $a = 1$, $f_D = 5 \text{ Hz}$	
Antenna configuration			4x2		2x2		4x2		2x2	
Beamforming Model			As specified in Section B.4.3				As specified in Section B.4.3			
Timing offset between TPs		us	0				0			
Frequency offset between TPs		Hz	0				0			
Cell-specific reference signals			Antenna ports 0,1				Antenna ports 0,1			
CSI-RS signal 0			Antenna ports 15,..., 18		N/A		Antenna ports 15,..., 18		N/A	
CSI-RS 0 periodicity and subframe offset $T_{\text{CSI-RS}} / \Delta_{\text{CSI-RS}}$			5/3		N/A		5/3		N/A	
CSI-RS 0 configuration			0		N/A		0		N/A	
CSI-RS signal 1			N/A		Antenna ports 15, 16		N/A		Antenna ports 15, 16	
CSI-RS 1 periodicity and subframe offset $T_{\text{CSI-RS}} / \Delta_{\text{CSI-RS}}$			N/A		5/3		N/A		5/3	
CSI-RS 1 configuration			N/A		5		N/A		5	
Zero-power CSI-RS 0 configuration $l_{\text{CSI-RS}} / \text{ZeroPowerCSI-RS}$ bitmap			N/A		3 / 1110000000 00000		N/A		3 / 1110000000 00000	
Zero-power CSI-RS 1 configuration $l_{\text{CSI-RS}} / \text{ZeroPowerCSI-RS}$ bitmap			3 / 00100110000 00000		N/A		3 / 00100110000 00000		N/A	
CSI-IM 0 periodicity and subframe offset $T_{\text{CSI-IM}} / \Delta_{\text{CSI-IM}}$			5/3		5/3		5/3		5/3	
CSI-IM 0 configuration			2		2		2		2	
CSI-IM 1 periodicity and subframe offset $T_{\text{CSI-IM}} / \Delta_{\text{CSI-IM}}$			5/3		N/A		5/3		N/A	
CSI-IM 1 configuration			6		N/A		6		N/A	
CSI-IM 2 periodicity and subframe offset $T_{\text{CSI-IM}} / \Delta_{\text{CSI-IM}}$			N/A		5/3		N/A		5/3	
CSI-IM 2 configuration			N/A		1		N/A		1	
CSI process 0	CSI-RS		CSI-RS 0				CSI-RS 0			
	CSI-IM		CSI-IM 0				CSI-IM 0			
	Reporting mode		PUCCH 1-1				PUCCH 1-1			
	CodeBookSubsetRestriction bitmap		0x0000 0000 0000 0001				0x0000 0000 0000 0001			
	Reporting periodicity	ms	$N_{pd} = 5$				$N_{pd} = 5$			
	CQI delay	ms	12				12			
	Physical channel for CQI/ PMI reporting		PUSCH (Note 6)				PUSCH (Note 6)			
	PUCCH Report		2				2			

	Type for CQI/PMI				
	PUCCH channel for RI reporting		PUCCH Format 2		PUCCH Format 2
	PUCCH report type for RI		3		3
	<i>cqi-pmi-ConfigurationIndex</i>		3		3
	<i>ri-ConfigIndex</i>		805 (Note 10)		805 (Note 10)
CSI process 1	CSI-RS		CSI-RS 1		CSI-RS 1
	CSI-IM		CSI-IM 0		CSI-IM 0
	Reporting mode		PUSCH 3-1		PUSCH 3-1
	CodeBookSubsetRestriction bitmap		000001		000001
	Reporting interval (Note 9)	ms	5		5
	CQI delay	ms	12		12
	Sub-band size	RB	6 (full size)		6 (full size)
CSI process 2	CSI-RS		CSI-RS 0		CSI-RS 0
	CSI-IM		CSI-IM 1		CSI-IM 1
	Reporting mode		PUSCH 3-1		PUSCH 3-1
	CodeBookSubsetRestriction bitmap		0x0000 0000 0000 0001		0x0000 0000 0000 0001
	Reporting interval (Note 9)	ms	5		5
	CQI delay	ms	12		12
	Sub-band size	RB	6 (full size) (Note 8)		6 (full size) (Note 8)
CSI process 3	CSI-RS		CSI-RS 1		CSI-RS 1
	CSI-IM		CSI-IM 2		CSI-IM 2
	Reporting mode		PUSCH 3-1		PUSCH 3-1
	CodeBookSubsetRestriction bitmap		000001		000001
	Reporting interval (Note 9)	ms	5		5
	CQI delay	ms	12		12
	Sub-band size	RB	6 (full size)		6 (full size)
CSI process for PDSCH scheduling			CSI process 2		CSI process 2
Cell ID		0	6	0	6
Quasi-co-located CSI-RS		CSI-RS 0	CSI-RS 1	CSI-RS 0	CSI-RS 1
Quasi-co-located CRS		Same Cell ID as Cell 1	Same Cell ID as Cell 2	Same Cell ID as Cell 1	Same Cell ID as Cell 2
PMI for subframe 4 and 9		0x0000 0000 0000 0001	100000	0x0000 0000 0000 0001	100000
PMI for subframe 3 and 8		0x0000 0000 0001 0000	100000	0x0000 0000 0001 0000	100000
Max number of HARQ transmissions		1	N/A	1	N/A
ACK/NACK feedback mode		Multiplexing	N/A	Multiplexing	N/A
Note 1:	If the UE reports in an available uplink reporting instance at subframe SF#n based on CQI estimation at a downlink SF not later than SF#(n-4), this reported wideband CQI cannot be applied at the eNB downlink before SF#(n+4)				
Note 2:	3 symbols allocated to PDCCH				
Note 3:	Reference measurement channel RC.12 TDD according to Table A.4-1. PDSCH transmission is scheduled on subframe 4 and 9 from TP1.				
Note 4:	TM10 OCNG OP.8 TDD is transmitted as specified in A.5.2.8 on subframe 3 and 8 from TP1.				
Note 5:	TM10 OCNG OP.8 TDD is transmitted as specified in A.5.2.8 on subframe 3, 4, 8 and 9 from TP2				
Note 6:	To avoid collisions between CQI/PMI reports and HARQ-ACK it is necessary to report both on PUSCH instead of PUCCH. PDCCH DCI format 0 shall be transmitted in downlink SF#3 and #8 to allow periodic CQI/PMI to multiplex with the HARQ-ACK on PUSCH in uplink SF#7 and #2.				
Note 7:	For each test, the minimum requirements shall be fulfilled for at least one of the two SNR(s) and the respective wanted signal input level.				
Note 8:	PDCCH DCI format 0 with a trigger for aperiodic CQI shall be transmitted in downlink SF#3 and #8 to allow aperiodic CQI/PMI/RI to be transmitted in uplink SF#7 and #2.				
Note 9:	For these sub-bands which are not selected for PDSCH transmission, TM10 OCNG should be transmitted.				
Note 10:	RI reporting interval is set to the maximum allowable length of 160ms to minimise collisions between RI, CQI/PMI and HARQ-ACK reports. In the case when all three reports collide, it is expected that CQI/PMI reports will be dropped, while RI and HARQ-ACK will be multiplexed. At eNB, CQI report collection shall be skipped every 160ms during performance verification and the reported CQI in subframe SF#7 of the previous frame is applied in downlink subframes until a new CQI (after CQI/PMI dropping) is available.				

Table 9.3.6.2-2: Minimum requirement (TDD)

	CSI process 0	CSI process 1	CSI process 2	CSI process 3
α [%]	N/A	2	2	2
β [%]	N/A	40	40	40
δ [%]	10	N/A	N/A	N/A
γ	N/A	N/A	1.02	N/A
UE Category	≥ 1			

Table 9.3.6.2-3: Minimum median CQI difference between configured CSI processes (TDD)

	CSI process 1	CSI process 2	CSI process 3
CSI process 0	N/A	1	3
UE Category	≥ 1		

9.3.7 Minimum requirement PUSCH 3-2

9.3.7.1 FDD

For the parameters specified in Table 9.3.7.1-1, and using the downlink physical channels specified in Annex C.3.2, the minimum requirements are specified in Table 9.3.7.1-2 and by the following.

- the ratio of the throughput obtained when transmitting based on UE PUSCH 3-2 reported wideband CQI and subband PMI and that obtained when transmitting based on PUSCH 3-1 reported wideband CQI and wideband PMI shall be $\geq \alpha$;
- The ratio of the throughput obtained when transmitting on a randomly selected sub-band among the sub-bands with the highest differential CQI offset level the corresponding TBS based on UE PUSCH3-2 reported subband CQI and subband PMI and that obtained when transmitting on a randomly selected sub-band in set S based on PUSCH 1-2 reported wideband CQI and subband PMI shall be $\geq \beta$;

The transport block sizes TBS for wideband CQI and subband CQI are selected according to RC.17 FDD for test 1 and according to RC.18 FDD for test 2.

Table 9.3.7.1-1 Sub-band test for FDD

Parameter		Unit	Test 1		Test 2	
Bandwidth		MHz	10MHz			
PDSCH resource allocation		RB	50PRB		a subband, 6PRB	
Transmission mode			TM6		TM9	
Downlink power allocation	ρ_A	dB	-6		0	
	ρ_B	dB	-6		0	
	P_c	dB	-		-3	
	σ	dB	3		-3	
SNR (Note 3)		dB	0	1	5	6
$\hat{I}_{or}^{(j)}$		dB[mW/15kHz]	-98	-97	-93	-92
$N_{oc}^{(j)}$		dB[mW/15kHz]	-98	-98	-98	-98
Propagation channel			EVA5		EVA5	
Antenna configuration			4x2 ULA low		4x2 XP high (Note 4)	
Beamforming Model			-		B.4.3	
CRS reference signals			Antenna ports 0, 1, 2, 3		Antenna ports 0, 1	
Time offset between TX antenna (Note 5)		ns	65		-	
CSI reference signals					Antenna ports 15, 16, 17, 18	
CSI-RS periodicity and subframe offset $T_{CSI-RS} / \Delta_{CSI-RS}$			-		5/ 1	
CSI-RS reference signal configuration alternativeCodebookEnabledFor4TX			-		4	
			No		Yes	
CodeBookSubsetRestriction bitmap			0x0000 0000 0000 FFFF		0x0000 0000 0000 FFFF 0000 FFFF	
Reporting interval (Note 6)		ms	5		5	
CQI delay		ms	8		8	
Reporting mode			PUSCH 3-2, PUSCH 3-1		PUSCH 3-2, PUSCH 1-2	
Sub-band size		RB	6 (full size)		6 (full size)	
Max number of HARQ transmissions			1		1	
<p>Note 1: If the UE reports in an available uplink reporting instance at subframe SF#n based on CQI estimation at a downlink subframe not later than SF#(n-4), this reported subband or wideband CQI cannot be applied at the eNB downlink before SF#(n+4)</p> <p>Note 2: Reference measurement channel RC.17 FDD / RC.18 FDD for Test 1 / 2 according to Table A.4-1 with one/two sided dynamic OCN Pattern OP.1/2 FDD as described in Annex A.5.1.1/2.</p> <p>Note 3: For each test, the minimum requirements shall be fulfilled for at least one of the two SNR(s) and the respective wanted signal input level.</p> <p>Note 4: Randomization of the principle beam direction shall be used as specified in B.2.3A.4.</p> <p>Note 5: The values of time offset are [0ns 65ns 0ns 65ns] for antenna port [0, 1, 2, 3] respectively.</p> <p>Note 6: PDCCH DCI format 0 with a trigger for aperiodic CQI shall be transmitted in downlink SF#1 and #6 to allow aperiodic CQI/PMI/RI to be transmitted in uplink SF#0 and #5.</p>						

Table 9.3.7.1-2 Minimum requirement (FDD)

	Test 1	Test 2
α	1.05	-
β	-	1.15
UE Category	≥ 2	≥ 2

9.3.7.2 TDD

For the parameters specified in Table 9.3.7.2-1, and using the downlink physical channels specified in Annex C.3.2, the minimum requirements are specified in Table 9.3.7.2-2 and by the following.

- a) the ratio of the throughput obtained when transmitting based on UE PUSCH 3-2 reported wideband CQI and subband PMI and that obtained when transmitting based on PUSCH 3-1 reported wideband CQI and wideband PMI shall be $\geq \alpha$;

- b) The ratio of the throughput obtained when transmitting on a randomly selected sub-band among the sub-bands with the highest differential CQI offset level the corresponding TBS based on UE PUSCH3-2 reported subband CQI and subband PMI and that obtained when transmitting on a randomly selected sub-band in set S based on PUSCH 1-2 reported wideband CQI and subband PMI shall be $\geq \beta$;

The transport block sizes TBS for wideband CQI and subband CQI are selected according to RC.17 TDD for test 1 and RC.18 TDD for test 2.

Table 9.3.7.2-1 Sub-band test for TDD

Parameter		Unit	Test 1		Test 2	
Bandwidth		MHz	10MHz			
PDSCH resource allocation		RB	50PRB		a subband, 6PRB	
Transmission mode			TM6		TM9	
Uplink downlink configuration			1		1	
Special subframe configuration			4		4	
Downlink power allocation	ρ_A	dB	-6		0	
	ρ_B	dB	-6		0	
	P_c	dB	-		-3	
	σ	dB	3		-3	
SNR (Note 3)		dB	0	1	5	6
$\hat{I}_{or}^{(j)}$		dB[mW/15kHz]	-98	-97	-93	-92
$N_{oc}^{(j)}$		dB[mW/15kHz]	-98	-98	-98	-98
Propagation channel			EVA5		EVA5	
Antenna configuration			4x2 ULA low		4x2 XP high (Note 4)	
Beamforming Model			-		B.4.3	
CRS reference signals			Antenna ports 0, 1, 2, 3		Antenna ports 0, 1	
Time offset between TX antenna (Note 5)		ns	65		-	
CSI reference signals					Antenna ports 15, 16, 17, 18	
CSI-RS periodicity and subframe offset $T_{CSI-RS} / \Delta_{CSI-RS}$			-		5/ 4	
CSI-RS reference signal configuration alternativeCodebookEnabledFor4TX			-		4	
CodeBookSubsetRestriction bitmap			No		Yes	
CodeBookSubsetRestriction bitmap			0x0000 0000 0000 FFFF		0x0000 0000 0000 FFFF 0000 FFFF	
Reporting interval (Note 6)		ms	5		5	
CQI delay		ms	8		8	
Reporting mode			PUSCH 3-2, PUSCH 3-1		PUSCH 3-2, PUSCH 1-2	
Sub-band size		RB	6 (full size)		6 (full size)	
Max number of HARQ transmissions			1		1	
<p>Note 1: If the UE reports in an available uplink reporting instance at subframe SF#n based on CQI estimation at a downlink subframe not later than SF#(n-4), this reported subband or wideband CQI cannot be applied at the eNB downlink before SF#(n+4)</p> <p>Note 2: Reference measurement channel RC.17 TDD / RC.18 TDD for Test 1 / 2 according to Table A.4-1 with one/two sided dynamic OCNB Pattern OP.1/2 TDD as described in Annex A.5.2.1/2.</p> <p>Note 3: For each test, the minimum requirements shall be fulfilled for at least one of the two SNR(s) and the respective wanted signal input level.</p> <p>Note 4: Randomization of the principle beam direction shall be used as specified in B.2.3A.4.</p> <p>Note 5: The values of time offset are [0ns 65ns 0ns 65ns] for antenna port [0, 1, 2, 3] respectively.</p> <p>Note 6: PDCCH DCI format 0 with a trigger for aperiodic CQI shall be transmitted in downlink SF#4 and #9 to allow aperiodic CQI/PMI/RI to be transmitted in uplink SF#3 and #8.</p>						

Table 9.3.7.2-2 Minimum requirement (TDD)

	Test 1	Test 2
α	1.05	-
β	-	1.15
UE Category	≥ 2	≥ 2

9.3.8 Additional requirements for enhanced receiver Type B

The purpose of the test is to verify that the reporting of the channel quality based on the receiver of the enhanced Type B meets a minimum performance. Performance requirements are specified in terms of the relative throughput obtained when the transport format is that indicated by the reported CQI with NeighCellsInfo-r12 configured compared to the case without NeighCellsInfo-r12 configured. Cell 1 is the serving cell, and Cell 2 and Cell 3 are the interference cells.

9.3.8.1 Minimum requirement PUCCH 1-1 (Cell-Specific Reference Symbols)

9.3.8.1.1 FDD

For the parameters specified in Table 9.3.8.1.1-1, and using the downlink physical channels specified in Annex C, the minimum requirements are specified in Table 9.3.8.1.1-2 and by the following

- a) the ratio of the throughput obtained when transmitting the transport format indicated by each reported wideband CQI index subject to interference sources with NeighCellsInfo-r12 configured and that obtained when transmitting the transport format indicated by each reported wideband CQI index subject to interference sources without NeighCellsInfo-r12 configured shall be $\geq \gamma$;

Table 9.3.8.1.1-1 Fading test for FDD

Parameter		Unit	Cell 1	Cell 2	Cell 3
Bandwidth		MHz	10		
Transmission mode			4		
Downlink power allocation	ρ_A	dB	-3		
	ρ_B	dB	-3		
	σ	dB	0		
Cyclic Prefix			Normal	Normal	Normal
Cell ID			0	1	6
SNR		dB	8.34	N/A	N/A
\hat{E}_s/N_{oc}			N/A	3.28	0.74
$\hat{I}_{or}^{(j)}$		dB [mW/15kHz]	-89.66	-94.72	-97.26
N_{oc}		dB [mW/15kHz]	-98		
Propagation channel			EPA5	EPA5	EPA5
Correlation and antenna configuration			Low 2 x 2	Low 2 x 2	Low 2 x 2
Cell-specific reference signals			Antenna ports 0,1	Antenna ports 0,1	Antenna ports 0,1
Interference model			N/A	As specified in clause B.6.3	As specified in clause B.6.3
Reporting periodicity		ms	$N_{pd} = 5$	N/A	N/A
Physical channel for CQI/PMI reporting			PUCCH Format 2	N/A	N/A
PUCCH Report Type for CQI/PMI			2	N/A	N/A
PUCCH Report Type for RI			3	N/A	N/A
<i>cqi-pmi-ConfigurationIndex</i>			6	N/A	N/A
<i>ri-ConfigurationIndex</i>			1	N/A	N/A
<i>CodeBookSubsetRestriction bitmap</i>			000001	N/A	N/A
Max number of HARQ transmissions			1	N/A	N/A
NeighCellsInfo-r12 (Note 4)	p-aList-r12		N/A	{dB-6, dB-3, dB0}	{dB-6, dB-3, dB0}
	transmissionModeList-r12		N/A	{2,3,4,8,9}	{2,3,4,8,9}
Note 1: If the UE reports in an available uplink reporting instance at subframe SF#n based on CQI estimation at a downlink SF not later than SF#(n-4), this reported wideband CQI cannot be applied at the eNB downlink before SF#(n+4)					
Note 2: Reference measurement channel RC.2 FDD according to Table A.4-1 with one sided dynamic OCNG Pattern OP.1 FDD as described in Annex A.5.1.1.					
Note 3: All cells are time-synchronous.					
Note 4: NeighCellsInfo-r12 is described in subclause 6.3.2 of [7].					

Table 9.3.8.1.1-2 Minimum requirement (FDD)

	Test
γ	0.925
UE Category	≥ 2

9.3.8.1.2 TDD

For the parameters specified in Table 9.3.8.1.2-1, and using the downlink physical channels specified in Annex C, the minimum requirements are specified in 9.3.8.1.2-2 and by the following

- the ratio of the throughput obtained when transmitting the transport format indicated by each reported wideband CQI index subject to interference sources with NeighCellsInfo-r12 configured and that obtained when transmitting the transport format indicated by each reported wideband CQI index subject to interference sources without NeighCellsInfo-r12 configured shall be $\geq \gamma$;

Table 9.3.8.1.2-1 Fading test for TDD

Parameter		Unit	Cell 1	Cell 2	Cell 3
Bandwidth		MHz		10	
Transmission mode				4	
Uplink downlink configuration				2	
Special subframe configuration				4	
Downlink power allocation	ρ_A	dB		-3	
	ρ_B	dB		-3	
	σ	dB		0	
Cyclic Prefix			Normal	Normal	Normal
Cell ID			0	1	6
SNR		dB	8.34	N/A	N/A
\hat{E}_s/N_{oc}			N/A	3.28	0.74
$\hat{I}_{or}^{(j)}$		dB [mW/15kHz]	-89.66	-94.72	-97.26
N_{oc}		dB [mW/15kHz]		-98	
Propagation channel			EPA5	EPA5	EPA5
Correlation and antenna configuration			Low 2 x 2	Low 2 x 2	Low 2 x 2
Cell-specific reference signals			Antenna ports 0,1	Antenna ports 0,1	Antenna ports 0,1
Interference model			N/A	As specified in clause B.6.3	As specified in clause B.6.3
Reporting periodicity		ms	$N_{pd} = 5$	N/A	N/A
Physical channel for CQI/PMI reporting			PUSCH (Note 3)	N/A	N/A
PUCCH Report Type			2	N/A	N/A
<i>cqi-pmi-ConfigurationIndex</i>			3	N/A	N/A
<i>ri-ConfigIndex</i>			805 (Note 5)	N/A	N/A
<i>CodeBookSubsetRestriction bitmap</i>			000001	N/A	N/A
Max number of HARQ transmissions			1	N/A	N/A
ACK/NACK feedback mode			Multiplexing	N/A	N/A
NeighCellsInfo-r12 (Note 6)	p-aList-r12		N/A	{dB-6, dB-3, dB0}	{dB-6, dB-3, dB0}
	transmissionModeList-r12		N/A	{2,3,4,8,9}	{2,3,4,8,9}
<p>Note 1: If the UE reports in an available uplink reporting instance at subframe SF#n based on CQI estimation at a downlink SF not later than SF#(n-4), this reported wideband CQI cannot be applied at the eNB downlink before SF#(n+4)</p> <p>Note 2: Reference measurement channel RC.2 TDD according to Table A.4-1 with one sided dynamic OCNG Pattern OP.1 TDD as described in Annex A.5.2.1.</p> <p>Note 3: To avoid collisions between CQI reports and HARQ-ACK it is necessary to report both on PUSCH instead of PUCCH. PDCCH DCI format 0 shall be transmitted in downlink SF#3 and #8 to allow periodic CQI to multiplex with the HARQ-ACK on PUSCH in uplink subframe SF#7 and #2.</p> <p>Note 4: All cells are time-synchronous.</p> <p>Note 5: RI reporting interval is set to the maximum allowable length of 160ms to minimise collisions between RI, CQI/PMI and HARQ-ACK reports. In the case when all three reports collide, it is expected that CQI/PMI reports will be dropped, while RI and HARQ-ACK will be multiplexed. At eNB, CQI report collection shall be skipped every 160ms during performance verification.</p> <p>Note 6: NeighCellsInfo-r12 is described in subclause 6.3.2 of [7].</p>					

Table 9.3.8.1.2-2 Minimum requirement (TDD)

	Test
γ	0.925
UE Category	≥ 2

9.3.8.2 Minimum requirement PUCCH 1-1 (CSI Reference Symbols)

9.3.8.2.1 FDD

For the parameters specified in Table 9.3.8.2.1-1, and using the downlink physical channels specified in Annex C, the minimum requirements are specified in Table 9.3.8.2.1-2 and by the following

- a) the ratio of the throughput obtained when transmitting the transport format indicated by each reported wideband CQI index subject to interference sources with NeighCellsInfo-r12 configured and that obtained when transmitting the transport format indicated by each reported wideband CQI index subject to interference sources without NeighCellsInfo-r12 configured shall be $\geq \gamma$;

Table 9.3.8.2.1-1 Fading test for FDD

Parameter		Unit	Cell 1	Cell 2	Cell 3
Bandwidth		MHz		10	
Transmission mode				9	
Downlink power allocation	ρ_A	dB		0	
	ρ_B	dB		0	
	P_c	dB		0	
	σ	dB		0	
Cyclic Prefix			Normal	Normal	Normal
Cell ID			0	1	6
SNR		dB	8.34	N/A	N/A
\hat{E}_s/N_{oc}			N/A	3.28	0.74
$\hat{I}_{or}^{(j)}$		dB [mW/15kHz]	-89.66	-94.72	-97.26
N_{oc}		dB [mW/15kHz]		-98	
Propagation channel			EPA5	EPA5	EPA5
Correlation and antenna configuration			Low 2 x 2	Low 2 x 2	Low 2 x 2
Cell-specific reference signals			Antenna ports 0,1	Antenna ports 0,1	Antenna ports 0,1
Beamforming Model			As specified in Section B.4.3		
CSI reference signals			Antenna ports 15,16	N/A	N/A
CSI-RS periodicity and subframe offset			5/1	N/A	N/A
CSI-RS reference signal configuration			2	N/A	N/A
Zero-power CSI-RS configuration $I_{CSI-RS} / ZeroPowerCSI-RS$ bitmap		Subframes / bitmap	N/A	1 / 00010000000000 00	1 / 00010000000000 00
CodeBookSubsetRestriction bitmap			000001	N/A	N/A
Interference model			N/A	As specified in clause B.6.4	As specified in clause B.6.4
Reporting periodicity		ms	$N_{pd} = 5$	N/A	N/A
Physical channel for CQI/PMI reporting			PUSCH (Note 3)	N/A	N/A
PUCCH Report Type for CQI/PMI			2	N/A	N/A
PUCCH channel for RI reporting			PUCCH Format 2	N/A	N/A
PUCCH Report Type for RI			3	N/A	N/A
$cqi-pmi-ConfigurationIndex$			2	N/A	N/A
$ri-ConfigIndex$			1	N/A	N/A
Max number of HARQ transmissions			1	N/A	N/A
NeighCellsInfo- r12 (Note 5)	p-aList-r12 transmission		N/A	{dB-6, dB-3, dB0}	{dB-6, dB-3, dB0}
	ModeList-r12		N/A	{2,3,4,8,9}	{2,3,4,8,9}
<p>Note 1: If the UE reports in an available uplink reporting instance at subframe SF#n based on CQI estimation at a downlink SF not later than SF#(n-4), this reported wideband CQI cannot be applied at the eNB downlink before SF#(n+4)</p> <p>Note 2: Reference measurement channel RC.11 FDD according to Table A.4-1 with one sided dynamic OCNG Pattern OP.1 FDD as described in Annex A.5.1.1.</p> <p>Note 3: To avoid collisions between CQI/PMI reports and HARQ-ACK it is necessary to report both on PUSCH instead of PUCCH. PDCCH DCI format 0 shall be transmitted in downlink SF#1 and #6 to allow periodic CQI/ PMI to multiplex with the HARQ-ACK on PUSCH in uplink subframe SF#0 and #5.</p> <p>Note 4: All cells are time-synchronous.</p> <p>Note 5: NeighCellsInfo-r12 is described in subclause 6.3.2 of [7].</p>					

Table 9.3.8.2.1-2 Minimum requirement (FDD)

	Test
γ	0.925
UE Category	≥ 2

9.3.8.2.2 TDD

For the parameters specified in Table 9.3.8.2.2-1, and using the downlink physical channels specified in Annex C, the minimum requirements are specified in 9.3.8.2.2-2 and by the following

- a) the ratio of the throughput obtained when transmitting the transport format indicated by each reported wideband CQI index subject to interference sources with NeighCellsInfo-r12 configured and that obtained when transmitting the transport format indicated by each reported wideband CQI index subject to interference sources without NeighCellsInfo-r12 configured shall be $\geq \gamma$;

Table 9.3.8.2.2-1 Fading test for TDD

Parameter		Unit	Cell 1	Cell 2	Cell 3
Bandwidth		MHz		10	
Transmission mode				9	
Downlink power allocation	ρ_A	dB		0	
	ρ_B	dB		0	
	ρ_C	dB		0	
	σ	dB		0	
Uplink downlink configuration				2	
Special subframe configuration				4	
Cyclic Prefix			Normal	Normal	Normal
Cell ID			0	1	6
SNR		dB	8.34	N/A	N/A
\tilde{E}_s/N_{oc}			N/A	3.28	0.74
$\hat{I}_{or}^{(j)}$		dB [mW/15kHz]	-89.66	-94.72	-97.26
N_{oc}		dB [mW/15kHz]		-98	
Propagation channel			EPA5	EPA5	EPA5
Correlation and antenna configuration			Low 2 x 2	Low 2 x 2	Low 2 x 2
Cell-specific reference signals			Antenna ports 0,1	Antenna ports 0,1	Antenna ports 0,1
Beamforming Model			As specified in Section B.4.3		
CSI reference signals			Antenna ports 15,16	N/A	N/A
CSI-RS periodicity and subframe offset			5/3	N/A	N/A
CSI-RS reference signal configuration			2	N/A	N/A
Zero-power CSI-RS configuration $I_{CSI-RS} / \text{ZeroPowerCSI-RS}$ bitmap		Subframes / bitmap	N/A	3 / 000100000000000	3 / 000100000000000
CodeBookSubsetRestriction bitmap			000001	N/A	N/A
Interference model			N/A	As specified in clause B.6.4	As specified in clause B.6.4
Reporting periodicity		ms	$N_{pd} = 5$	N/A	N/A
Physical channel for CQI/PMI reporting			PUSCH (Note 3)	N/A	N/A
PUCCH Report Type for CQI/PMI			2	N/A	N/A
Physical channel for RI reporting			PUCCH Format 2	N/A	N/A
PUCCH Report Type for RI			3	N/A	N/A
$cqi\text{-}pmi\text{-}ConfigurationIndex$			3	N/A	N/A
$ri\text{-}ConfigIndex$			805 (Note 5)	N/A	N/A
Max number of HARQ transmissions			1	N/A	N/A
ACK/NACK feedback mode			Multiplexing	N/A	N/A
NeighCellsInfo-r12 (Note 6)	p-aList-r12		N/A	{dB-6, dB-3, dB0}	{dB-6, dB-3, dB0}
	transmission ModeList-r12		N/A	{2,3,4,8,9}	{2,3,4,8,9}
<p>Note 1: If the UE reports in an available uplink reporting instance at subframe SF#n based on CQI estimation at a downlink SF not later than SF#(n-4), this reported wideband CQI cannot be applied at the eNB downlink before SF#(n+4)</p> <p>Note 2: Reference measurement channel RC.11 TDD according to Table A.4-1 with one sided dynamic OCNG Pattern OP.1 TDD as described in Annex A.5.2.1.</p> <p>Note 3: To avoid collisions between CQI/PMI reports and HARQ-ACK it is necessary to report both on PUSCH instead of PUCCH. PDCCH DCI format 0 shall be transmitted in downlink SF#3 and #8 to allow periodic CQI/ PMI to multiplex with the HARQ-ACK on PUSCH in uplink subframe SF#2 and #7.</p> <p>Note 4: All cells are time-synchronous.</p>					

Note 5:	RI reporting interval is set to the maximum allowable length of 160ms to minimise collisions between RI, CQI/PMI and HARQ-ACK reports. In the case when all three reports collide, it is expected that CQI/PMI reports will be dropped, while RI and HARQ-ACK will be multiplexed. At eNB, CQI report collection shall be skipped every 160ms during performance verification and the reported CQI in subframe SF#7 of the previous frame is applied in downlink subframes until a new CQI (after CQI/PMI dropping) is available.
Note 6:	NeighCellsInfo-r12 is described in subclause 6.3.2 of [7].

Table 9.3.8.2.2-2 Minimum requirement (TDD)

	Test
γ	0.925
UE Category	≥ 2

9.3.8.3 Minimum requirement with CSI process

9.3.8.3.1 FDD

For the parameters specified in Table 9.3.8.3.1-1, and using the downlink physical channels specified in Annex C, the minimum requirements are specified in Table 9.3.8.3.1-2 and by the following

- a) the ratio of the throughput obtained for the Type B receiver with NAICS assistance information when transmitting the transport format indicated by each reported wideband CQI index subject to interference sources with specified \hat{E}_s/N_{oc} and that obtained for the Type B receiver without NAICS assistance information when transmitting the transport format indicated by each reported wideband CQI index subject to interference sources with the same specified \hat{E}_s/N_{oc} shall be $\geq \gamma$;

Table 9.3.8.3.1-1 Fading test for single antenna (FDD)

Parameter		Unit	Cell 1	Cell 2	Cell 3
Bandwidth		MHz	10		
Transmission mode			10	9	9
Downlink power allocation	ρ_A	dB	0		
	ρ_B	dB	0		
	P_c	dB	0		
	σ	dB	0		
Cyclic Prefix			Normal	Normal	Normal
Cell ID			0	1	6
SNR		dB	8.34	N/A	N/A
\bar{E}_s/N_{oc}		dB	N/A	3.28	0.74
$\hat{I}_{or}^{(j)}$		dB [mW/15kHz]	-89.66	-94.72	-97.26
N_{oc}		dB[mW/15kHz]	-98		
Propagation channel			EPA5	EPA5	EPA5
Correlation and antenna configuration			Low 2 x 2	Low 2 x 2	Low 2 x 2
Cell-specific reference signals			Antenna ports 0,1	Antenna port 0, 1	Antenna port 0, 1
Beamforming Model			As specified in Section B.4.3		
CSI reference signals			Antenna ports 15,16	N/A	N/A
CSI-RS periodicity and subframe offset			5/1	N/A	N/A
CSI-RS reference signal configuration			2	N/A	N/A
Zero-power CSI-RS configuration l_{CSI-RS} / $ZeroPowerCSI-RS$ bitmap		Subframes / bitmap	N/A	1 / 000100000000 0000	1 / 000100000000 000
Interference model			N/A	As specified in clause B.6.4	As specified in clause B.6.4
CSI process	CSI-RS		CSI-RS	N/A	N/A
	CSI-IM		CSI-IM	N/A	N/A
	Reporting mode		PUCCH 1-1	N/A	N/A
	CodeBookSubsetRestriction bitmap		000001	N/A	N/A
	Reporting periodicity	ms	$N_{pd} = 5$	N/A	N/A
	CQI delay	ms	8	N/A	N/A
	Physical channel for CQI/ PMI reporting		PUSCH (Note 3)	N/A	N/A
	PUCCH Report Type for CQI/PMI		2	N/A	N/A
	PUCCH channel for RI reporting		PUCCH Format 2	N/A	N/A
	PUCCH report type for RI		3	N/A	N/A
	$cqi-pmi-ConfigurationIndex$		2	N/A	N/A
$ri-ConfigIndex$		1	N/A	N/A	
CSI-IM periodicity and subframe offset $T_{CSI-RS} / \Delta_{CSI-RS}$			5/1	N/A	N/A
CSI-IM configuration			6	N/A	N/A
CSI process for PDSCH scheduling			CSI process	N/A	N/A
Quasi-co-located CSI-RS			CSI-RS	N/A	N/A
Quasi-co-located CRS			Same Cell ID as Cell 1	N/A	N/A
Reference measurement channel			Note 2	N/A	N/A
Max number of HARQ transmissions			1	N/A	N/A
NeighCellsInfo-r12 (Note 5)	p-aList-r12		N/A	{dB-6, dB-3, dB0}	{dB-6, dB-3, dB0}
	transmissionModeList-r12		N/A	{2,3,4,8,9}	{2,3,4,8,9}
Note 1: If the UE reports in an available uplink reporting instance at subframe SF#n based on CQI estimation at a downlink SF not later than SF#(n-4), this reported wideband CQI cannot be applied at the eNB downlink before SF#(n+4)					
Note 2: Reference measurement channel RC.11 FDD according to Table A.4-1 with one sided dynamic OCNB Pattern					

	OP.1 FDD as described in Annex A.5.1.1.
Note 3:	To avoid collisions between CQI/ PMI reports and HARQ-ACK it is necessary to report both on PUSCH instead of PUCCH. PDCCH DCI format 0 shall be transmitted in downlink SF#1 and #6 to allow periodic CQI/ PMI to multiplex with the HARQ-ACK on PUSCH in uplink subframe SF#0 and #5.
Note 4:	All cells are time-synchronous.
Note 5:	NeighCellsInfo-r12 is described in subclause 6.3.2 of [7].

Table 9.3.8.3.1-2 Minimum requirement (FDD)

	Test
γ	0.925
UE Category	≥ 2

9.3.8.3.2 TDD

For the parameters specified in Table 9.3.8.3.2-1, and using the downlink physical channels specified in Annex C, the minimum requirements are specified in Table 9.3.8.3.2-2 and by the following

- a) the ratio of the throughput obtained for the Type B receiver with NAICS assistance information when transmitting the transport format indicated by each reported wideband CQI index subject to interference sources with specified \hat{E}_s/N_{oc} and that obtained for the Type B receiver without NAICS assistance information when transmitting the transport format indicated by each reported wideband CQI index subject to interference sources with the same specified \hat{E}_s/N_{oc} shall be $\geq \gamma$;

Table 9.3.8.3.2-1 Fading test for single antenna (TDD)

Parameter		Unit	Cell 1	Cell 2	Cell 3
Bandwidth		MHz	10		
Transmission mode			10	9	9
Downlink power allocation	ρ_A	dB	0		
	ρ_B	dB	0		
	ρ_C	dB	0		
	σ	dB	0		
Uplink downlink configuration			2		
Special subframe configuration			4		
Cyclic Prefix			Normal	Normal	Normal
Cell ID			0	1	6
SNR		dB	8.34	N/A	N/A
\hat{E}_s/N_{oc}		dB	N/A	3.28	0.74
$\hat{I}_{or}^{(j)}$		dB [mW/15kHz]	-89.66	-94.72	-97.26
N_{oc}		dB[mW/15kHz]	-98		
Propagation channel			EPA5	EPA5	EPA5
Correlation and antenna configuration			Low 2 x 2	Low 2 x 2	Low 2 x 2
Cell-specific reference signals			Antenna ports 0,1	Antenna port 0,1	Antenna port 0,1
Beamforming Model			As specified in Section B.4.3		
CSI reference signals			Antenna ports 15,16	N/A	N/A
CSI-RS periodicity and subframe offset			5/3	N/A	N/A
CSI-RS reference signal configuration			2	N/A	N/A
Zero-power CSI-RS configuration l_{CSI-RS} / $ZeroPowerCSI-RS$ bitmap		Subframes / bitmap	N/A	3 / 000100000000 0000	3 / 000100000000 000
Interference model			N/A	As specified in clause B.6.4	As specified in clause B.6.4
CSI process	CSI-RS		CSI-RS	N/A	N/A
	CSI-IM		CSI-IM	N/A	N/A
	Reporting mode		PUCCH 1-1	N/A	N/A
	CodeBookSubsetRestriction bitmap		000001	N/A	N/A
	Reporting periodicity	ms	$N_{pd} = 5$	N/A	N/A
	CQI delay	ms	8	N/A	N/A
	Physical channel for CQI/ PMI reporting		PUSCH (Note 3)	N/A	N/A
	PUCCH Report Type for CQI/PMI		2	N/A	N/A
	PUCCH channel for RI reporting		PUCCH Format 2	N/A	N/A
	PUCCH report type for RI		3	N/A	N/A
	$cqi-pmi-ConfigurationIndex$		3	N/A	N/A
$ri-ConfigIndex$		805 (Note 5)	N/A	N/A	
CSI-IM periodicity and subframe offset T_{CSI-RS} / Δ_{CSI-RS}			5/1	N/A	N/A
CSI-IM configuration			6	N/A	N/A
CSI process for PDSCH scheduling			CSI process	N/A	N/A
Quasi-co-located CSI-RS			CSI-RS	N/A	N/A
Quasi-co-located CRS			Same Cell ID as Cell 1	N/A	N/A
Reference measurement channel			Note 2	N/A	N/A
Max number of HARQ transmissions			1	N/A	N/A
ACK/NACK feedback mode			Multiplexing	N/A	N/A
NeighCellsInfo-r12 (Note 6)	p-aList-r12		N/A	{dB-6, dB-3, dB0}	{dB-6, dB-3, dB0}
	transmissionModeList-r12		N/A	{2,3,4,8,9}	{2,3,4,8,9}
Note 1: If the UE reports in an available uplink reporting instance at subframe SF#n based on CQI estimation at a					

	downlink SF not later than SF#(n-4), this reported wideband CQI cannot be applied at the eNB downlink before SF#(n+4)
Note 2:	Reference measurement channel RC.11 TDD according to Table A.4-1 with one sided dynamic OCNG Pattern OP.1 TDD as described in Annex A.5.2.1.
Note 3:	To avoid collisions between CQI/ PMI reports and HARQ-ACK it is necessary to report both on PUSCH instead of PUCCH. PDCCH DCI format 0 shall be transmitted in downlink SF#1 and #6 to allow periodic CQI/ PMI to multiplex with the HARQ-ACK on PUSCH in uplink subframe SF#0 and #5.
Note 4:	All cells are time-synchronous.
Note 5:	RI reporting interval is set to the maximum allowable length of 160ms to minimise collisions between RI, CQI/PMI and HARQ-ACK reports. In the case when all three reports collide, it is expected that CQI/PMI reports will be dropped, while RI and HARQ-ACK will be multiplexed. At eNB, CQI report collection shall be skipped every 160ms during performance verification and the reported CQI in subframe SF#7 of the previous frame is applied in downlink subframes until a new CQI (after CQI/PMI dropping) is available.
Note 6:	NeighCellsInfo-r12 is described in subclause 6.3.2 of [7].

Table 9.3.8.3.2-2 Minimum requirement (TDD)

	Test
γ	0.925
UE Category	≥ 2

9.4 Reporting of Precoding Matrix Indicator (PMI)

The minimum performance requirements of PMI reporting are defined based on the precoding gain, expressed as the relative increase in throughput when the transmitter is configured according to the UE reports compared to the case when the transmitter is using random precoding, respectively. When the transmitter uses random precoding, for each PDSCH allocation a precoder is randomly generated and applied to the PDSCH. A fixed transport format (FRC) is configured for all requirements.

The requirements for transmission mode 6 and transmission mode 9 with 4 TX are specified in terms of the ratio

$$\gamma = \frac{t_{ue}}{t_{rnd}}$$

In the definition of γ , for PUSCH 3-1 single PMI and PUSCH 1-2 multiple PMI requirements, t_{rnd} is 60% of the maximum throughput obtained at SNR_{rnd} using random precoding, and t_{ue} the throughput measured at SNR_{rnd} with precoders configured according to the UE reports;

For the PUCCH 2-1 single PMI requirement, t_{rnd} is 60% of the maximum throughput obtained at SNR_{rnd} using random precoding on a randomly selected full-size subband in set S subbands, and t_{ue} the throughput measured at SNR_{rnd} with both the precoder and the preferred full-size subband applied according to the UE reports;

For PUSCH 2-2 multiple PMI requirements, t_{rnd} is 60% of the maximum throughput obtained at SNR_{rnd} using random precoding on a randomly selected full-size subband in set S subbands, and t_{ue} the throughput measured at SNR_{rnd} with both the subband precoder and a randomly selected full-size subband (within the preferred subbands) applied according to the UE reports.

The requirements for transmission mode 9 with 8 TX and transmission mode 9 with 4TX enhanced codebook are specified in terms of the ratio

$$\gamma = \frac{t_{ue, follow1, follow2}}{t_{rnd1, rnd2}}$$

In the definition of γ , for PUSCH 3-1 single PMI, PUCCH 1-1 single PMI and PUSCH 1-2 multiple PMI requirements, $t_{follow1, follow2}$ is 70% of the maximum throughput obtained at $SNR_{follow1, follow2}$ using the precoders configured according to the UE reports, and $t_{rnd1, rnd2}$ is the throughput measured at $SNR_{follow1, follow2}$ with random precoding .

9.4.1 Single PMI

9.4.1.1 Minimum requirement PUSCH 3-1 (Cell-Specific Reference Symbols)

9.4.1.1.1 FDD

For the parameters specified in Table 9.4.1.1.1-1, and using the downlink physical channels specified in Annex C.3.2, the minimum requirements are specified in Table 9.4.1.1.1-2.

Table 9.4.1.1.1-1: PMI test for single-layer (FDD)

Parameter	Unit	Test 1	
Bandwidth	MHz	10	
Transmission mode		6	
Propagation channel		EVA5	
Precoding granularity	PRB	50	
Correlation and antenna configuration		Low 2 x 2	
Downlink power allocation	ρ_A	dB	-3
	ρ_B	dB	-3
	σ	dB	0
$N_{oc}^{(j)}$	dB[mW/15kHz]	-98	
Reporting mode		PUSCH 3-1	
Reporting interval	ms	1	
PMI delay (Note 2)	ms	8	
Measurement channel		R. 10 FDD	
OCNG Pattern		OP.1 FDD	
Max number of HARQ transmissions		4	
Redundancy version coding sequence		{0,1,2,3}	
Note 1: For random precoder selection, the precoder shall be updated in each TTI (1 ms granularity). Note 2: If the UE reports in an available uplink reporting instance at subframe SF#n based on PMI estimation at a downlink SF not later than SF#(n-4), this reported PMI cannot be applied at the eNB downlink before SF#(n+4).			

Table 9.4.1.1.1-2 Minimum requirement (FDD)

Parameter	Test 1
γ	1.1
UE Category	≥ 1

9.4.1.1.2 TDD

For the parameters specified in Table 9.4.1.1.2-1, and using the downlink physical channels specified in Annex C.3.2, the minimum requirements are specified in 9.4.1.1.2-2.

Table 9.4.1.1.2-1: PMI test for single-layer (TDD)

Parameter	Unit	Test 1	
Bandwidth	MHz	10	
Transmission mode		6	
Uplink downlink configuration		1	
Special subframe configuration		4	
Propagation channel		EVA5	
Precoding granularity	PRB	50	
Correlation and antenna configuration		Low 2 x 2	
Downlink power allocation	ρ_A	dB	-3
	ρ_B	dB	-3
	σ	dB	0
$N_{oc}^{(j)}$	dB[mW/15kHz]	-98	
Reporting mode		PUSCH 3-1	
Reporting interval	ms	1	
PMI delay (Note 2)	ms	10 or 11	
Measurement channel		R.10 TDD	
OCNG Pattern		OP.1 TDD	
Max number of HARQ transmissions		4	
Redundancy version coding sequence		{0,1,2,3}	
ACK/NACK feedback mode		Multiplexing	
Note 1: For random precoder selection, the precoder shall be updated in each available downlink transmission instance. Note 2: If the UE reports in an available uplink reporting instance at subframe SF#n based on PMI estimation at a downlink SF not later than SF#(n-4), this reported PMI cannot be applied at the eNB downlink before SF#(n+4).			

Table 9.4.1.1.2-2: Minimum requirement (TDD)

Parameter	Test 1
γ	1.1
UE Category	≥ 1

9.4.1.2 Minimum requirement PUCCH 2-1 (Cell-Specific Reference Symbols)

9.4.1.2.1 FDD

For the parameters specified in Table 9.4.1.2.1-1, and using the downlink physical channels specified in Annex C.3.2, the minimum requirements are specified in Table 9.4.1.2.1-2.

Table 9.4.1.2.1-1: PMI test for single-layer (FDD)

Parameter		Unit	Test 1
Bandwidth		MHz	10
Transmission mode			6
Propagation channel			EVA5
Correlation and antenna configuration			Low 4 x 2
Downlink power allocation	ρ_A	dB	-6
	ρ_B	dB	-6
	σ	dB	3
$N_{oc}^{(j)}$		dB[mW/15kHz]	-98
PMI delay		ms	8 or 9
Reporting mode			PUCCH 2-1 (Note 6)
Reporting periodicity		ms	$N_{pd} = 2$
Physical channel for CQI reporting			PUSCH (Note 3)
PUCCH Report Type for wideband CQI/PMI			2
PUCCH Report Type for subband CQI			1
Measurement channel			R.14-1 FDD
OCNG Pattern			OP. 1/2 FDD
Precoding granularity		PRB	6 (full size)
Number of bandwidth parts (J)			3
K			1
<i>cqi-pmi-ConfigIndex</i>			1
Max number of HARQ transmissions			4
Redundancy version coding sequence			{0,1,2,3}
<p>Note 1: For random precoder selection, the precoder shall be updated every two TTI (2 ms granularity).</p> <p>Note 2: If the UE reports in an available uplink reporting instance at subframe SF#n based on PMI estimation at a downlink SF not later than SF#(n-4), this reported PMI cannot be applied at the eNB downlink before SF#(n+4).</p> <p>Note 3: To avoid collisions between HARQ-ACK and wideband CQI/PMI or subband CQI, it is necessary to report both on PUSCH instead of PUCCH. PDCCH DCI format 0 shall be transmitted in downlink SF#1, #3, #7 and #9 to allow periodic CQI to multiplex with the HARQ-ACK on PUSCH in uplink subframe SF#5, #7, #1 and #3.</p> <p>Note 4: Reports for the short subband (having 2RBs in the last bandwidth part) are to be disregarded and instead data is to be transmitted on the most recently used subband for bandwidth part with $j=1$.</p> <p>Note 5: In the case where wideband PMI is reported, data is to be transmitted on the most recently used subband.</p> <p>Note 6: The bit field for PMI confirmation in DCI format 1B shall be mapped to "0" and TPMI information shall indicate the codebook index used in Table 6.3.4.2.3-2 of TS36.211 [4] according to the latest PMI report on PUCCH.</p>			

Table 9.4.1.2.1-2: Minimum requirement (FDD)

	Test 1
γ	1.2
UE Category	≥ 1

9.4.1.2.2 TDD

For the parameters specified in Table 9.4.1.2.2-1, and using the downlink physical channels specified in Annex C.3.2, the minimum requirements are specified in Table 9.4.1.2.2-2.

Table 9.4.1.2.2-1: PMI test for single-layer (TDD)

Parameter	Unit	Test 1	
Bandwidth	MHz	10	
Transmission mode		6	
Uplink downlink configuration		1	
Special subframe configuration		4	
Propagation channel		EVA5	
Correlation and antenna configuration		Low 4 x 2	
Downlink power allocation	ρ_A	dB	-6
	ρ_B	dB	-6
	σ	dB	3
$N_{oc}^{(j)}$	dB[mW/15kHz]	-98	
PMI delay	ms	10	
Reporting mode		PUCCH 2-1 (Note 6)	
Reporting periodicity	ms	$N_P = 5$	
Physical channel for CQI reporting		PUSCH (Note 3)	
PUCCH Report Type for wideband CQI/PMI		2	
PUCCH Report Type for subband CQI		1	
Measurement channel		R.14-1 TDD	
OCNG Pattern		OP.1/2 TDD	
Precoding granularity	PRB	6 (full size)	
Number of bandwidth parts (J)		3	
K		1	
$cqi-pmi-ConfigIndex$		4	
Max number of HARQ transmissions		4	
Redundancy version coding sequence		{0,1,2,3}	
ACK/NACK feedback mode		Multiplexing	
Note 1:	For random precoder selection, the precoder shall be updated in each available downlink transmission instance.		
Note 2:	If the UE reports in an available uplink reporting instance at subframe SF#n based on PMI estimation at a downlink SF not later than SF#(n-4), this reported PMI cannot be applied at the eNB downlink before SF#(n+4).		
Note 3:	To avoid collisions between HARQ-ACK and wideband CQI/PMI or subband CQI it is necessary to report both on PUSCH instead of PUCCH. PDCCH DCI format 0 shall be transmitted in downlink SF#4 and #9 to allow periodic CQI to multiplex with the HARQ-ACK on PUSCH in uplink subframe SF#8 and #3.		
Note 4:	Reports for the short subband (having 2RBs in the last bandwidth part) are to be disregarded and instead data is to be transmitted on the most recently used subband for bandwidth part with $j=1$.		
Note 5:	In the case where wideband PMI is reported, data is to be transmitted on the most recently used subband.		
Note 6:	The bit field for PMI confirmation in DCI format 1B shall be mapped to "0" and TPMI information shall indicate the codebook index used in Table 6.3.4.2.3-2 of TS36.211 [4] according to the latest PMI report on PUCCH.		

Table 9.4.1.2.2-2: Minimum requirement (TDD)

	Test 1
γ	1.2
UE Category	≥ 1

9.4.1.3 Minimum requirement PUSCH 3-1 (CSI Reference Symbol)

9.4.1.3.1 FDD

For the parameters specified in Table 9.4.1.3.1-1, and using the downlink physical channels specified in Annex C.3.2, the minimum requirements are specified in Table 9.4.1.3.1-2.

Table 9.4.1.3.1-1: PMI test for single-layer (FDD)

Parameter	Unit	Test 1	
Bandwidth	MHz	10	
Transmission mode		9	
Propagation channel		EPA5	
Precoding granularity	PRB	50	
Correlation and antenna configuration		Low ULA 4 x 2	
Cell-specific reference signals		Antenna ports 0,1	
CSI reference signals		Antenna ports 15,...,18	
Beamforming model		Annex B.4.3	
CSI-RS periodicity and subframe offset $T_{\text{CSI-RS}} / \Delta_{\text{CSI-RS}}$		5/ 1	
CSI-RS reference signal configuration		6	
CodeBookSubsetRestriction bitmap		0x0000 0000 0000 FFFF	
Downlink power allocation	ρ_A	dB	0
	ρ_B	dB	0
	P_c	dB	-3
	σ	dB	-3
$N_{oc}^{(j)}$	dB[mW/15kHz]	-98	
Reporting mode		PUSCH 3-1	
Reporting interval	ms	5	
PMI delay (Note 2)	ms	8	
Measurement channel		R.44 FDD	
OCNG Pattern		OP.1 FDD	
Max number of HARQ transmissions		4	
Redundancy version coding sequence		{0,1,2,3}	
Note 1:	For random precoder selection, the precoder shall be updated in each TTI (1 ms granularity).		
Note 2:	If the UE reports in an available uplink reporting instance at subframe SF#n based on PMI estimation at a downlink SF not later than SF#(n-4), this reported PMI cannot be applied at the eNB downlink before SF#(n+4).		
Note 3:	PDSCH_RA= 0 dB, PDSCH_RB= 0 dB in order to have the same PDSCH and OCNG power per subcarrier at the receiver.		

Table 9.4.1.3.1-2: Minimum requirement (FDD)

Parameter	Test 1
γ	1.2
UE Category	≥ 1

9.4.1.3.2 TDD

For the parameters specified in Table 9.4.1.3.2-1, and using the downlink physical channels specified in Annex C.3.2, the minimum requirements are specified in Table 9.4.1.3.2-2.

Table 9.4.1.3.2-1: PMI test for single-layer (TDD)

Parameter	Unit	Test 1	
Bandwidth	MHz	10	
Transmission mode		9	
Uplink downlink configuration		1	
Special subframe configuration		4	
Propagation channel		EVA5	
Precoding granularity	PRB	50	
Antenna configuration		8 x 2	
Correlation modeling		High, Cross polarized	
Cell-specific reference signals		Antenna ports 0,1	
CSI reference signals		Antenna ports 15,...,22	
Beamforming model		Annex B.4.3	
CSI-RS periodicity and subframe offset $T_{\text{CSI-RS}} / \Delta_{\text{CSI-RS}}$		5/ 4	
CSI-RS reference signal configuration		0	
CodeBookSubsetRestriction bitmap		0x0000 0000 001F FFE0 0000 0000 FFFF	
Downlink power allocation	ρ_A	dB	0
	ρ_B	dB	0
	P_c	dB	-6
	σ	dB	-3
$N_{oc}^{(j)}$	dB[mW/15kHz]	-98	
Reporting mode		PUSCH 3-1	
Reporting interval	ms	5	
PMI delay (Note 2)	ms	10	
Measurement channel		R.45-1 TDD for UE Category 1, R.45 TDD for UE Category ≥ 2	
OCNG Pattern		OP.7 TDD for UE Category 1, and OP.1 TDD for UE Category ≥ 2	
Max number of HARQ transmissions		4	
Redundancy version coding sequence		{0,1,2,3}	
ACK/NACK feedback mode		Multiplexing	
Note 1:	For random precoder selection, the precoder shall be updated in each TTI (1 ms granularity).		
Note 2:	If the UE reports in an available uplink reporting instance at subframe SF#n based on PMI estimation at a downlink SF not later than SF#(n-4), this reported PMI cannot be applied at the eNB downlink before SF#(n+4).		
Note 3:	PDCCH DCI format 0 with a trigger for aperiodic CQI shall be transmitted in downlink SF#4 and #9 to allow aperiodic CQI/PMI/RI to be transmitted on uplink SF#3 and #8.		

Note 4: Randomization of the principle beam direction shall be used as specified in B.2.3A.4
--

Table 9.4.1.3.2-2: Minimum requirement (TDD)

Parameter	Test 1
γ	3
UE Category	≥ 1

9.4.1.4 Minimum requirement PUCCH 1-1 (CSI Reference Symbol)

9.4.1.4.1 FDD (with 4Tx enhanced codebook)

For the parameters specified in Table 9.4.1.4.1-1, and using the downlink physical channels specified in Annex C.3.2, the minimum requirements are specified in Table 9.4.1.4.1-2.

Table 9.4.1.4.1-1 PMI test for single-layer (FDD)

Parameter	Unit	Test 1	
Bandwidth	MHz	10	
Transmission mode		9	
Propagation channel		EPA5	
Precoding granularity	PRB	50	
Correlation and antenna configuration		High XP 4 x 2	
Beamforming model		Annex B.4.3	
Cell-specific reference signals		Antenna ports 0,1	
CSI reference signals		Antenna ports 15,...,18	
CSI-RS periodicity and subframe offset $T_{\text{CSI-RS}} / \Delta_{\text{CSI-RS}}$		5/ 1	
CSI-RS reference signal configuration		6	
CodeBookSubsetRestriction bitmap		0x0000 0000 0000 FFFF 0000 00FF	
Downlink power allocation	ρ_A	dB	0
	ρ_B	dB	0
	P_c	dB	-3
	σ	dB	-3
$N_{oc}^{(j)}$	dB[mW/15kHz]	-98	
Reporting mode		PUCCH 1-1 submode1	
Reporting interval	ms	5	
PMI delay (Note 2)	ms	10	
Physical channel for CQI/PMI reporting		PUSCH (Note 3)	
PUCCH Report Type for CQI/second PMI		2b	
Physical channel for RI reporting		PUSCH	
PUCCH Report Type for RI/first PMI		5	
<i>cqi-pmi-ConfigurationIndex</i>		4	
<i>ri-ConfigIndex</i>		1	
Measurement channel		R.60 FDD	
OCNG Pattern		OP.1 FDD	
Max number of HARQ transmissions		4	
Redundancy version coding sequence		{0,1,2,3}	
alternativeCodeBookEnable dFor4TX-r12		True	
Note 1:	For random precoder selection, the precoder shall be updated in each TTI (1 ms granularity)		
Note 2:	If the UE reports in an available uplink reporting instance at subframe SF#n based on PMI estimation at a downlink SF not later than SF#(n-4), this reported PMI cannot be applied at the eNB downlink before SF#(n+4).		
Note 3:	To avoid collisions between CQI/PMI reports and HARQ-ACK it is necessary to report both on PUSCH instead of PUCCH.		
Note 4:	PDSCH_RA= 0 dB, PDSCH_RB= 0 dB in order to have the same PDSCH and OCNG power per subcarrier at the receiver.		
Note 5:	Randomization of the principle beam direction shall be used as specified in B.2.3A.4		

Table 9.4.1.4.1-2 Minimum requirement (FDD)

Parameter	Test 1
γ	1.8
UE Category	≥ 1

9.4.1.4.2 TDD (with 4Tx enhanced codebook)

For the parameters specified in Table 9.4.1.4.2-1, and using the downlink physical channels specified in Annex C.3.2, the minimum requirements are specified in Table 9.4.1.4.2-2.

Table 9.4.1.4.2-1 PMI test for single-layer (TDD)

Parameter	Unit	Test 1	
Bandwidth	MHz	10	
Transmission mode		9	
Uplink downlink configuration		1	
Special subframe configuration		4	
Propagation channel		EPA5	
Precoding granularity	PRB	50	
Correlation and antenna configuration		High XP 4 x 2	
Beamforming model		Annex B.4.3	
Cell-specific reference signals		Antenna ports 0,1	
CSI reference signals		Antenna ports 15,...,18	
CSI-RS periodicity and subframe offset $T_{\text{CSI-RS}} / \Delta_{\text{CSI-RS}}$		5/ 4	
CSI-RS reference signal configuration		6	
CodeBookSubsetRestriction bitmap		0x0000 0000 0000 FFFF 0000 00FF	
Downlink power allocation	ρ_A	dB	0
	ρ_B	dB	0
	P_c	dB	-3
	σ	dB	-3
$N_{oc}^{(j)}$	dB[mW/15kHz]	-98	
Reporting mode		PUCCH 1-1 submode1	
Reporting interval	ms	5	
PMI delay (Note 2)	ms	15	
Physical channel for CQI/PMI reporting		PUSCH (Note 3)	
PUCCH Report Type for CQI/second PMI		2b	
Physical channel for RI reporting		PUSCH	
PUCCH Report Type for RI/first PMI		5	
<i>cqi-pmi-ConfigurationIndex</i>		4	
<i>ri-ConfigIndex</i>		1	
Measurement channel		R.60 TDD	
OCNG Pattern		OP.1 TDD	
Max number of HARQ transmissions		4	
Redundancy version coding sequence		{0,1,2,3}	
ACK/NACK feedback mode		Multiplexing	
alternativeCodeBookEnable dFor4TX-r12		True	
Note 1:	For random precoder selection, the precoder shall be updated in each TTI (1 ms granularity)		
Note 2:	If the UE reports in an available uplink reporting instance at subframe SF#n based on PMI estimation at a downlink SF not later than SF#(n-4), this reported PMI cannot be applied at the eNB downlink before SF#(n+4).		
Note 3:	To avoid collisions between CQI/PMI reports and HARQ-ACK it is necessary to report both on PUSCH instead of PUCCH.		
Note 4:	PDCCH DCI format 0 with a trigger for aperiodic CQI shall be transmitted in downlink SF#4 and #9 to allow aperiodic		

Note 5: CQI/PMI/RI to be transmitted on uplink SF#3 and #8.
Randomization of the principle beam direction shall be used as specified in B.2.3A.4.

Table 9.4.1.4.2-2 Minimum requirement (TDD)

Parameter	Test 1
γ	1.8
UE Category	≥ 1

9.4.1a Void

9.4.1a.1 Void

9.4.1a.1.1 Void

9.4.1a.1.2 Void

9.4.2 Multiple PMI

9.4.2.1 Minimum requirement PUSCH 1-2 (Cell-Specific Reference Symbols)

9.4.2.1.1 FDD

For the parameters specified in Table 9.4.2.1.1-1, and using the downlink physical channels specified in Annex C.3.2, the minimum requirements are specified in 9.4.2.1.1-2.

Table 9.4.2.1.1-1: PMI test for single-layer (FDD)

Parameter	Unit	Test 1	
Bandwidth	MHz	10	
Transmission mode		6	
Propagation channel		EPA5	
Precoding granularity (only for reporting and following PMI)	PRB	6	
Correlation and antenna configuration		Low 2 x 2	
Downlink power allocation	ρ_A	dB	-3
	ρ_B	dB	-3
	σ	dB	0
$N_{oc}^{(j)}$	dB[mW/15kHz]	-98	
Reporting mode		PUSCH 1-2	
Reporting interval	ms	1	
PMI delay	ms	8	
Measurement channel		R.11-3 FDD for UE Category 1, R.11 FDD for UE Category ≥ 2	
OCNG Pattern		OP.1/2 FDD	
Max number of HARQ transmissions		4	
Redundancy version coding sequence		{0,1,2,3}	
Note 1:	For random precoder selection, the precoders shall be updated in each TTI (1 ms granularity).		
Note 2:	If the UE reports in an available uplink reporting instance at subframe SF#n based on PMI estimation at a downlink SF not later than SF#(n-4), this reported PMI cannot be applied at the eNB downlink before SF#(n+4).		
Note 3:	One/two sided dynamic OCNG Pattern OP.1/2 FDD as described in Annex A.5.1.1/2 shall be used.		

Table 9.4.2.1.1-2: Minimum requirement (FDD)

Parameter	Test 1
γ	1.2
UE Category	≥ 1

9.4.2.1.2 TDD

For the parameters specified in Table 9.4.2.1.2-1, and using the downlink physical channels specified in Annex C.3.2, the minimum requirements are specified in 9.4.2.1.2-2.

Table 9.4.2.1.2-1: PMI test for single-layer (TDD)

Parameter		Unit	Test 1
Bandwidth		MHz	10
Transmission mode			6
Uplink downlink configuration			1
Special subframe configuration			4
Propagation channel			EPA5
Precoding granularity (only for reporting and following PMI)		PRB	6
Correlation and antenna configuration			Low 2 x 2
Downlink power allocation	ρ_A	dB	-3
	ρ_B	dB	-3
	σ	dB	0
$N_{oc}^{(j)}$		dB[mW/15kHz]	-98
Reporting mode			PUSCH 1-2
Reporting interval		ms	1
PMI delay		ms	10 or 11
Measurement channel			R.11-3 TDD for UE Category 1 R.11 TDD for UE Category ≥ 2
OCNG Pattern			OP.1/2 TDD
Max number of HARQ transmissions			4
Redundancy version coding sequence			{0,1,2,3}
ACK/NACK feedback mode			Multiplexing
<p>Note 1: For random precoder selection, the precoders shall be updated in each available downlink transmission instance.</p> <p>Note 2: If the UE reports in an available uplink reporting instance at subframe SF#n based on PMI estimation at a downlink SF not later than SF#(n-4), this reported PMI cannot be applied at the eNB downlink before SF#(n+4).</p> <p>Note 3: One/two sided dynamic OCNG Pattern OP.1/2 TDD as described in Annex A.5.2.1/2 shall be used.</p>			

Table 9.4.2.1.2-2: Minimum requirement (TDD)

Parameter	Test 1
γ	1.2
UE Category	≥ 1

9.4.2.2 Minimum requirement PUSCH 2-2 (Cell-Specific Reference Symbols)

9.4.2.2.1 FDD

For the parameters specified in Table 9.4.2.2.1-1, and using the downlink physical channels specified in Annex C.3.2, the minimum requirements are specified in Table 9.4.2.2.1-2.

Table 9.4.2.2.1-1: PMI test for single-layer (FDD)

Parameter		Unit	Test 1
Bandwidth		MHz	10
Transmission mode			6
Propagation channel			EVA5
Correlation and antenna configuration			Low 4 x 2
Downlink power allocation	ρ_A	dB	-6
	ρ_B	dB	-6
	σ	dB	3
$N_{oc}^{(j)}$		dB[mW/15kHz]	-98
PMI delay		ms	8
Reporting mode			PUSCH 2-2
Reporting interval		ms	1
Measurement channel			R.14-2 FDD
OCNG Pattern			OP. 1/2 FDD
Subband size (k)		RBs	3 (full size)
Number of preferred subbands (M)			5
Max number of HARQ transmissions			4
Redundancy version coding sequence			{0,1,2,3}
Note 1: For random precoder selection, the precoder shall be updated in each TTI (1 ms granularity)			
Note 2: If the UE reports in an available uplink reporting instance at subframe SF#n based on PMI estimation at a downlink SF not later than SF#(n-4), this reported PMI cannot be applied at the eNB downlink before SF#(n+4)			

Table 9.4.2.2.1-2: Minimum requirement (FDD)

	Test 1
γ	1.2
UE Category	≥ 1

9.4.2.2.2 TDD

For the parameters specified in Table 9.4.2.2.2-1, and using the downlink physical channels specified in Annex C.3.2, the minimum requirements are specified in Table 9.4.2.2.2-2.

Table 9.4.2.2-1: PMI test for single-layer (TDD)

Parameter	Unit	Test 1	
Bandwidth	MHz	10	
Transmission mode		6	
Uplink downlink configuration		1	
Special subframe configuration		4	
Propagation channel		EVA5	
Correlation and antenna configuration		Low 4 x 2	
Downlink power allocation	ρ_A	dB	-6
	ρ_B	dB	-6
	σ	dB	3
$N_{oc}^{(j)}$	dB[mW/15kHz]	-98	
PMI delay	ms	10	
Reporting mode		PUSCH 2-2	
Reporting interval	ms	1	
Measurement channel		R.14-2 TDD	
OCNG Pattern		OP.1/2 TDD	
Subband size (k)	RBs	3 (full size)	
Number of preferred subbands (M)		5	
Max number of HARQ transmissions		4	
Redundancy version coding sequence		{0,1,2,3}	
ACK/NACK feedback mode		Multiplexing	
Note 1: For random precoder selection, the precoders shall be updated in each available downlink transmission instance. Note 2: If the UE reports in an available uplink reporting instance at subframe SF# n based on PMI estimation at a downlink SF not later than SF#(n-4), this reported PMI cannot be applied at the eNB downlink before SF#(n+4).			

Table 9.4.2.2-2 Minimum requirement (TDD)

	Test 1
γ	1.15
UE Category	≥ 1

9.4.2.3 Minimum requirement PUSCH 1-2 (CSI Reference Symbol)

9.4.2.3.1 FDD

For the parameters specified in Table 9.4.2.3.1-1, and using the downlink physical channels specified in Annex C.3.2, the minimum requirements are specified in 9.4.2.3.1-2.

Table 9.4.2.3.1-1: PMI test for single-layer (FDD)

Parameter	Unit	Test 1	
Bandwidth	MHz	10	
Transmission mode		9	
Propagation channel		EVA5	
Precoding granularity (only for reporting and following PMI)	PRB	6	
Correlation and antenna configuration		Low ULA 4 x 2	
Cell-specific reference signals		Antenna ports 0,1	
CSI reference signals		Antenna ports 15,...,18	
Beamforming model		Annex B.4.3	
CSI-RS periodicity and subframe offset $T_{\text{CSI-RS}} / \Delta_{\text{CSI-RS}}$		5/ 1	
CSI-RS reference signal configuration		8	
CodeBookSubsetRestriction restriction bitmap		0x0000 0000 0000 FFFF	
Downlink power allocation	ρ_A	dB	0
	ρ_B	dB	0
	P_c	dB	-3
	σ	dB	-3
$N_{oc}^{(j)}$	dB[mW/15kHz]	-98	
Reporting mode		PUSCH 1-2	
Reporting interval	ms	5	
PMI delay	ms	8	
Measurement channel		R.45-1 FDD for UE Category 1, R.45 FDD for UE Category ≥ 2	
OCNG Pattern		OP.7 FDD for UE Category 1 OP.1 FDD for UE Category ≥ 2	
Max number of HARQ transmissions		4	
Redundancy version coding sequence		{0,1,2,3}	
<p>Note 1: For random precoder selection, the precoders shall be updated in each TTI (1 ms granularity).</p> <p>Note 2: If the UE reports in an available uplink reporting instance at subframe SF#n based on PMI estimation at a downlink SF not later than SF#(n-4), this reported PMI cannot be applied at the eNB downlink before SF#(n+4).</p> <p>Note 3: Void.</p> <p>Note 4: PDSCH_RA= 0 dB, PDSCH_RB= 0 dB in order to have the same PDSCH and OCNG power per subcarrier at the receiver.</p>			

Table 9.4.2.3.1-2: Minimum requirement (FDD)

Parameter	Test 1
γ	1.3
UE Category	≥ 1

9.4.2.3.2 TDD

For the parameters specified in Table 9.4.2.3.2-1, and using the downlink physical channels specified in Annex C.3.2, the minimum requirements are specified in 9.4.2.3.2-2.

Table 9.4.2.3.2-1: PMI test for single-layer (TDD)

Parameter	Unit	Test 1	
Bandwidth	MHz	10	
Transmission mode		9	
Uplink downlink configuration		1	
Special subframe configuration		4	
Propagation channel		EVA5	
Precoding granularity (only for reporting and following PMI)	PRB	6	
Antenna configuration		8 x 2	
Correlation modeling		High, Cross polarized	
Cell-specific reference signals		Antenna ports 0,1	
CSI reference signals		Antenna ports 15,...,22	
Beamforming model		Annex B.4.3	
CSI-RS periodicity and subframe offset $T_{\text{CSI-RS}} / \Delta_{\text{CSI-RS}}$		5/ 4	
CSI-RS reference signal configuration		4	
CodeBookSubsetRestriction bitmap		0x0000 0000 001F FFE0 0000 0000 FFFF	
Downlink power allocation	ρ_A	dB	0
	ρ_B	dB	0
	P_c	db	-6
	σ	dB	-3
$N_{oc}^{(j)}$	dB[mW/15kHz]	-98	
Reporting mode		PUSCH 1-2	
Reporting interval	ms	5 (Note 4)	
PMI delay	ms	10	
Measurement channel		R.45-1 TDD for UE Category 1, R.45 TDD for UE Category ≥ 2	
OCNG Pattern		OP.7 TDD for UE Category 1 OP.1 TDD for UE Category ≥ 2	
Max number of HARQ transmissions		4	
Redundancy version coding sequence		{0,1,2,3}	
ACK/NACK feedback mode		Multiplexing	
<p>Note 1: For random precoder selection, the precoders shall be updated in each TTI (1 ms granularity).</p> <p>Note 2: If the UE reports in an available uplink reporting instance at subframe SF#n based on PMI estimation at a downlink SF not later than SF#(n-4), this reported PMI cannot be applied at the eNB downlink before SF#(n+4).</p> <p>Note 3: One/two sided dynamic OCNG Pattern OP.1/2 TDD as described in Annex A.5.2.1/2 shall be</p>			

	used.
Note 4:	PDCCH DCI format 0 with a trigger for aperiodic CQI shall be transmitted in downlink SF#4 and #9 to allow aperiodic CQI/PMI/RI to be transmitted on uplink SF#3 and #8.
Note 5:	Randomization of the principle beam direction shall be used as specified in B.2.3A.4.

Table 9.4.2.3.2-2: Minimum requirement (TDD)

Parameter	Test 1
γ	3.5
UE Category	≥ 1

9.4.2.3.3 FDD (with 4Tx enhanced codebook)

For the parameters specified in Table 9.4.2.3.3-1, and using the downlink physical channels specified in Annex C.3.2, the minimum requirements are specified in 9.4.2.3.3-2.

Table 9.4.2.3.3-1 PMI test for dual-layer (FDD)

Parameter		Unit	Test 1
Bandwidth		MHz	10
Transmission mode			9
Propagation channel			EVA5
Precoding granularity (only for reporting and following PMI)		PRB	6
Correlation and antenna configuration			High XP 4 x 2
Beamforming model			Annex B.4.3
Cell-specific reference signals			Antenna ports 0,1
CSI reference signals			Antenna ports 15,...,18
CSI-RS periodicity and subframe offset $T_{\text{CSI-RS}} / I_{\text{CSI-RS}}$			5/ 1
CSI-RS reference signal configuration			8
CodeBookSubsetRestriction bitmap			0x0000 0000 FFFF 0000 FFFF 0000
Downlink power allocation	ρ_A	dB	0
	ρ_B	dB	0
	P_c	dB	-3
	σ	dB	-3
$N_{oc}^{(j)}$		dB[mW/15kHz]	-98
Reporting mode			PUSCH1-2
Reporting interval		ms	5
PMI delay (Note 2)		ms	8
Measurement channel			R.45-1 FDD for UE Category 1, R.45 FDD for UE Category ≥ 2
Rank Number of PDSCH			2
OCNG Pattern			OP.7 FDD for UE Category 1 OP.1 FDD for UE Category ≥ 2
Max number of HARQ transmissions			4
Redundancy version coding sequence			{0,1,2,3}
alternativeCodeBookEnable dFor4TX-r12			True
<p>Note 1: For random precoder selection, the precoder shall be updated in each TTI (1 ms granularity)</p> <p>Note 2: If the UE reports in an available uplink reporting instance at subframe SF#n based on PMI estimation at a downlink SF not later than SF#(n-4), this reported PMI cannot be applied at the eNB downlink before SF#(n+4).</p> <p>Note 3: Void.</p> <p>Note 4: PDSCH_RA= 0 dB, PDSCH_RB= 0 dB in order to have the same PDSCH and OCNG power per subcarrier at the receiver.</p> <p>Note 5: Randomization of the principle beam direction shall be used as specified in B.2.3A.4</p>			

Table 9.4.2.3.3-2 Minimum requirement (FDD)

Parameter	Test 1
γ	1.2
UE Category	≥ 1

9.4.2.3.4 TDD (with 4Tx enhanced codebook)

For the parameters specified in Table 9.4.2.3.4-1, and using the downlink physical channels specified in Annex C.3.2, the minimum requirements are specified in 9.4.2.3.4-2.

Table 9.4.2.3.4-1 PMI test for dual-layer (TDD)

Parameter	Unit	Test 1	
Bandwidth	MHz	10	
Transmission mode		9	
Uplink downlink configuration		1	
Special subframe configuration		4	
Propagation channel		EVA5	
Precoding granularity (only for reporting and following PMI)	PRB	6	
Correlation and antenna configuration		XP High 4 x 2	
Beamforming model		Annex B.4.3	
Cell-specific reference signals		Antenna ports 0,1	
CSI reference signals		Antenna ports 15,...,18	
CSI-RS periodicity and subframe offset $T_{\text{CSI-RS}} / I_{\text{CSI-RS}}$		5/ 4	
CSI-RS reference signal configuration		4	
CodeBookSubsetRestriction bitmap		0x0000 0000 FFFF 0000 FFFF 0000	
Downlink power allocation	ρ_A	dB	0
	ρ_B	dB	0
	P_c	dB	-3
	σ	dB	-3
$N_{oc}^{(j)}$	dB[mW/15kHz]	-98	
Reporting mode		PUSCH1-2	
Reporting interval	ms	5	
PMI delay (Note 2)	ms	10	
Measurement channel		R.61-1 TDD for UE Category 1, R.61 TDD for UE Category ≥ 2	
Rank Number of PDSCH		2	
OCNG Pattern		OP.7 FDD for UE Category 1 OP.1 FDD for UE Category ≥ 2	
Max number of HARQ transmissions		4	
Redundancy version coding sequence		{0,1,2,3}	
ACK/NACK feedback mode		Multiplexing	
alternativeCodeBookEnable dFor4TX-r12		True	
Note 1:	For random precoder selection, the precoder shall be updated in each TTI (1 ms granularity)		
Note 2:	If the UE reports in an available uplink reporting instance at subframe SF#n based on PMI estimation at a downlink SF not later than SF#(n-4), this reported PMI cannot be applied at the eNB downlink before SF#(n+4).		
Note3:	Void.		
Note 4:	PDCCH DCI format 0 with a trigger for aperiodic CQI shall be transmitted in downlink SF#4 and #9 to allow aperiodic CQI/PMI/RI to be transmitted on uplink SF#3 and #8.		
Note 5:	Randomization of the principle beam direction shall be used as specified in B.2.3A.4.		

Table 9.4.2.3.4-2 Minimum requirement (TDD)

Parameter	Test 1
γ	1.2
UE Category	≥ 1

9.4.3 Void

9.4.3.1 Void

9.4.3.1.1 Void

9.4.3.1.2 Void

9.5 Reporting of Rank Indicator (RI)

The purpose of this test is to verify that the reported rank indicator accurately represents the channel rank. The accuracy of RI (CQI) reporting is determined by the relative increase of the throughput obtained when transmitting based on the reported rank compared to the case for which a fixed rank is used for transmission. Transmission mode 4 is used with the specified CodebookSubSetRestriction in section 9.5.1, transmission mode 9 is used with the specified CodebookSubSetRestriction in section 9.5.2 and transmission mode 3 is used with the specified CodebookSubSetRestriction in section 9.5.3, and transmission mode 10 is used with the specified CodebookSubSetRestriction in section 9.5.5.

For fixed rank 1 transmission in sections 9.5.1, 9.5.2 and 9.5.5, the RI and PMI reporting is restricted to two single-layer precoders, For fixed rank 2 transmission in sections 9.5.1, 9.5.2 and 9.5.5, the RI and PMI reporting is restricted to one two-layer precoder, For follow RI transmission in sections 9.5.1 and 9.5.2, the RI and PMI reporting is restricted to select the union of these precoders. Channels with low and high correlation are used to ensure that RI reporting reflects the channel condition.

For fixed rank 1 transmission in section 9.5.3, the RI reporting is restricted to single-layer, for fixed rank 2 transmission in section 9.5.3, the RI reporting is restricted to two-layers. For follow RI transmission in section 9.5.3, the RI reporting is either one or two layers.

9.5.1 Minimum requirement (Cell-Specific Reference Symbols)

9.5.1.1 FDD

The minimum performance requirement in Table 9.5.1.1-2 is defined as

- a) The ratio of the throughput obtained when transmitting based on UE reported RI and that obtained when transmitting with fixed rank 1 shall be $\geq \gamma_1$;
- b) The ratio of the throughput obtained when transmitting based on UE reported RI and that obtained when transmitting with fixed rank 2 shall be $\geq \gamma_2$;

For the parameters specified in Table 9.5.1.1-1, and using the downlink physical channels specified in Annex C.3.2, the minimum requirements are specified in Table 9.5.1.1-2.

Table 9.5.1.1-1: RI Test (FDD)

Parameter	Unit	Test 1	Test 2	Test 3
Bandwidth	MHz		10	
PDSCH transmission mode			4	
Downlink power allocation	ρ_A	dB	-3	
	ρ_B	dB	-3	
	σ	dB	0	
Propagation condition and antenna configuration		2 x 2 EPA5		
CodeBookSubsetRestriction bitmap		000011 for fixed RI = 1 010000 for fixed RI = 2 010011 for UE reported RI		
Antenna correlation		Low	Low	High
RI configuration		Fixed RI=2 and follow RI	Fixed RI=1 and follow RI	Fixed RI=1 and follow RI
SNR	dB	0	20	20
$N_{oc}^{(j)}$	dB[mW/15kHz]	-98	-98	-98
$\hat{I}_{or}^{(j)}$	dB[mW/15kHz]	-98	-78	-78
Maximum number of HARQ transmissions		1		
Reporting mode		PUCCH 1-1 (Note 4)		
Physical channel for CQI/PMI reporting		PUCCH Format 2		
PUCCH Report Type for CQI/PMI		2		
Physical channel for RI reporting		PUSCH (Note 3)		
PUCCH Report Type for RI		3		
Reporting periodicity	ms	$N_{pd}=5$		
PMI and CQI delay	ms	8		
<i>cqi-pmi-ConfigurationIndex</i>		6		
<i>ri-ConfigurationInd</i>		1 (Note 5)		
<p>Note 1: If the UE reports in an available uplink reporting instance at subframe SF#n based on PMI and CQI estimation at a downlink subframe not later than SF#(n-4), this reported PMI and wideband CQI cannot be applied at the eNB downlink before SF#(n+4).</p> <p>Note 2: Reference measurement channel RC.2 FDD according to Table A.4-1 with one sided dynamic OCNG Pattern OP.1 FDD as described in Annex A.5.1.1.</p> <p>Note 3: To avoid collisions between RI reports and HARQ-ACK it is necessary to report both on PUSCH instead of PUCCH. PDCCH DCI format 0 shall be transmitted in downlink SF#4 and #9 to allow periodic RI to multiplex with the HARQ-ACK on PUSCH in uplink subframe SF#8 and #3.</p> <p>Note 4: The bit field for precoding information in DCI format 2 shall be mapped as:</p> <ul style="list-style-type: none"> • For reported RI = 1 and PMI = 0 >> precoding information bit field index = 1 • For reported RI = 1 and PMI = 1 >> precoding information bit field index = 2 • For reported RI = 2 and PMI = 0 >> precoding information bit field index = 0 <p>Note 5: To avoid the ambiguity of TE behaviour when applying CQI and PMI during rank switching, RI reports are to be applied at the TE with one subframe delay in addition to Note 1 to align with CQI and PMI reports.</p>				

Table 9.5.1.1-2: Minimum requirement (FDD)

	Test 1	Test 2	Test 3
γ_1	N/A	1.05	0.9
γ_2	1	N/A	N/A
UE Category	≥ 2	≥ 2	≥ 2

9.5.1.2 TDD

The minimum performance requirement in Table 9.5.1.2-2 is defined as

- a) The ratio of the throughput obtained when transmitting based on UE reported RI and that obtained when transmitting with fixed rank 1 shall be $\geq \gamma_1$;
- b) The ratio of the throughput obtained when transmitting based on UE reported RI and that obtained when transmitting with fixed rank 2 shall be $\geq \gamma_2$;

For the parameters specified in Table 9.5.1.2-1, and using the downlink physical channels specified in Annex C.3.2, the minimum requirements are specified in Table 9.5.1.2-2.

Table 9.5.1.2-1: RI Test (TDD)

Parameter	Unit	Test 1	Test 2	Test 3
Bandwidth	MHz	10		
PDSCH transmission mode		4		
Downlink power allocation	ρ_A	dB	-3	
	ρ_B	dB	-3	
	σ	dB	0	
Uplink downlink configuration		2		
Special subframe configuration		4		
Propagation condition and antenna configuration		2 x 2 EPA5		
CodeBookSubsetRestriction bitmap		000011 for fixed RI = 1 010000 for fixed RI = 2 010011 for UE reported RI		
Antenna correlation		Low	Low	High
RI configuration		Fixed RI=2 and follow RI	Fixed RI=1 and follow RI	Fixed RI=1 and follow RI
SNR	dB	0	20	20
$N_{oc}^{(j)}$	dB[mW/15kHz]	-98	-98	-98
$\hat{I}_{or}^{(j)}$	dB[mW/15kHz]	-98	-78	-78
Maximum number of HARQ transmissions		1		
Reporting mode		PUSCH 3-1 (Note 3)		
Reporting interval	ms	5		
PMI and CQI delay	ms	10 or 11		
ACK/NACK feedback mode		Bundling		
Note 1:	If the UE reports in an available uplink reporting instance at subframe SF#n based on PMI and CQI estimation at a downlink subframe not later than SF#(n-4), this reported PMI and wideband CQI cannot be applied at the eNB downlink before SF#(n+4).			
Note 2:	Reference measurement channel RC.2 TDD according to Table A.4-1 with one sided dynamic OCNG Pattern OP.1 TDD as described in Annex A.5.2.1.			
Note 3:	Reported wideband CQI and PMI are used and sub-band CQI is discarded.			

Table 9.5.1.2-2: Minimum requirement (TDD)

	Test 1	Test 2	Test 3
γ_1	N/A	1.05	0.9
γ_2	1	N/A	N/A
UE Category	≥ 2	≥ 2	≥ 2

9.5.2 Minimum requirement (CSI Reference Symbols)

9.5.2.1 FDD

The minimum performance requirement in Table 9.5.2.1-2 is defined as

- a) The ratio of the throughput obtained when transmitting based on UE reported RI and that obtained when transmitting with fixed rank 1 shall be $\geq \gamma_1$;

- b) The ratio of the throughput obtained when transmitting based on UE reported RI and that obtained when transmitting with fixed rank 2 shall be $\geq \gamma_2$;

For the parameters specified in Table 9.5.2.1-1, and using the downlink physical channels specified in Annex C.3.2, the minimum requirements are specified in Table 9.5.2.1-2.

Table 9.5.2.1-1: RI Test (FDD)

Parameter		Unit	Test 1	Test 2	Test 3
Bandwidth		MHz	10		
PDSCH transmission mode			9		
Downlink power allocation	ρ_A	dB	0		
	ρ_B	dB	0		
	ρ_C	dB	0		
	σ	dB	0		
Propagation condition and antenna configuration			2 x 2 EPA5		
Cell-specific reference signals			Antenna ports 0		
Beamforming Model			As specified in Section B.4.3		
CSI reference signals			Antenna ports 15, 16		
CSI-RS periodicity and subframe offset $T_{\text{CSI-RS}} / \Delta_{\text{CSI-RS}}$			5/1		
CSI reference signal configuration			6		
CodeBookSubsetRestriction bitmap			000011 for fixed RI = 1 010000 for fixed RI = 2 010011 for UE reported RI		
Antenna correlation			Low	Low	High
RI configuration			Fixed RI=2 and follow RI	Fixed RI=1 and follow RI	Fixed RI=1 and follow RI
SNR		dB	0	20	20
$N_{oc}^{(j)}$		dB[mW/15kHz]	-98	-98	-98
$\hat{I}_{or}^{(j)}$		dB[mW/15kHz]	-98	-78	-78
Maximum number of HARQ transmissions			1		
Reporting mode			PUCCH 1-1		
Physical channel for CQI/PMI reporting			PUSCH (Note 3)		
PUCCH Report Type for CQI/PMI			2		
Physical channel for RI reporting			PUCCH Format 2		
PUCCH Report Type for RI			3		
Reporting periodicity		ms	$N_{pd} = 5$		
PMI and CQI delay		ms	8		
<i>cqi-pmi-ConfigurationIndex</i>			2		
<i>ri-ConfigurationIndex</i>			1 (Note 4)		
<p>Note 1: If the UE reports in an available uplink reporting instance at subframe SF#n based on PMI and CQI estimation at a downlink subframe not later than SF#(n-4), this reported PMI and wideband CQI cannot be applied at the eNB downlink before SF#(n+4).</p> <p>Note 2: Reference measurement channel RC.9 FDD according to Table A.4-1 with one sided dynamic OCNG Pattern OP.1 FDD as described in Annex A.5.1.1.</p> <p>Note 3: To avoid collisions between CQI/ PMI reports and HARQ-ACK it is necessary to report both on PUSCH instead of PUCCH. PDCCH DCI format 0 shall be transmitted in downlink SF#1 and #6 to allow periodic CQI/ PMI to multiplex with the HARQ-ACK on PUSCH in uplink SF#0 and #5.</p> <p>Note 4: To avoid the ambiguity of TE behaviour when applying CQI and PMI during rank switching, RI reports are to be applied at the TE with one subframe delay in addition to Note 1 to align with CQI and PMI reports.</p>					

Table 9.5.2.1-2: Minimum requirement (FDD)

	Test 1	Test 2	Test 3
γ_1	N/A	1.05	0.9
γ_2	1	N/A	N/A
UE Category	≥ 2	≥ 2	≥ 2

9.5.2.2 TDD

The minimum performance requirement in Table 9.5.2.2-2 is defined as

- a) The ratio of the throughput obtained when transmitting based on UE reported RI and that obtained when transmitting with fixed rank 1 shall be $\geq \gamma_1$;
- b) The ratio of the throughput obtained when transmitting based on UE reported RI and that obtained when transmitting with fixed rank 2 shall be $\geq \gamma_2$;

For the parameters specified in Table 9.5.2.2-1, and using the downlink physical channels specified in Annex C.3.2, the minimum requirements are specified in Table 9.5.2.2-2.

Table 9.5.2.2-1: RI Test (TDD)

Parameter		Unit	Test 1	Test 2	Test 3
Bandwidth		MHz		10	
PDSCH transmission mode				9	
Downlink power allocation	ρ_A	dB		0	
	ρ_B	dB		0	
	P_c	dB		0	
	σ	dB		0	
Uplink downlink configuration				1	
Special subframe configuration				4	
Propagation condition and antenna configuration				2 x 2 EPA5	
Cell-specific reference signals				Antenna ports 0	
CSI reference signals				Antenna ports 15, 16	
Beamforming Model				As specified in Section B.4.3	
CSI reference signal configuration				4	
CSI-RS periodicity and subframe offset $T_{\text{CSI-RS}} / \Delta_{\text{CSI-RS}}$				5/4	
CodeBookSubsetRestriction bitmap				000011 for fixed RI = 1 010000 for fixed RI = 2 010011 for UE reported RI	
Antenna correlation			Low	Low	High
RI configuration			Fixed RI=2 and follow RI	Fixed RI=1 and follow RI	Fixed RI=1 and follow RI
SNR		dB	0	20	20
$N_{oc}^{(j)}$		dB[mW/15kHz]	-98	-98	-98
$\hat{I}_{or}^{(j)}$		dB[mW/15kHz]	-98	-78	-78
Maximum number of HARQ transmissions			1		
Reporting mode			PUCCH 1-1		
Physical channel for CQI/ PMI reporting			PUSCH (Note 3)		
PUCCH report type for CQI/ PMI			2		
Physical channel for RI reporting			PUCCH Format 2		
Reporting periodicity		ms	$N_{pd} = 5$		
PMI and CQI delay		ms	10		
ACK/NACK feedback mode			Bundling		
<i>cqi-pmi-ConfigurationIndex</i>			4		
<i>ri-ConfigurationInd</i>			1		
<p>Note 1: If the UE reports in an available uplink reporting instance at subframe SF#n based on PMI and CQI estimation at a downlink subframe not later than SF#(n-4), this reported PMI and wideband CQI cannot be applied at the eNB downlink before SF#(n+4).</p> <p>Note 2: Reference measurement channel RC.9 TDD according to Table A.4-1 with one sided dynamic OCNG Pattern OP.1 TDD as described in Annex A.5.2.1.</p> <p>Note 3: To avoid collisions between CQI/PMI reports and HARQ-ACK it is necessary to report both on PUSCH instead of PUCCH. PDCCH DCI format 0 shall be transmitted in downlink SF#4 and #9 to allow periodic CQI/PMI to multiplex with the HARQ-ACK on PUSCH in uplink SF#3 and #8.</p>					

Table 9.5.2.2-2: Minimum requirement (TDD)

	Test 1	Test 2	Test 3
γ_1	N/A	1.05	0.9
γ_2	1	N/A	N/A
UE Category	≥ 2	≥ 2	≥ 2

9.5.3 Minimum requirement (CSI measurements in case two CSI subframe sets are configured)

9.5.3.1 FDD

The minimum performance requirement in Table 9.5.3.1-2 is defined as

- a) The ratio of the throughput obtained when transmitting based on UE reported RI and that obtained when transmitting with fixed rank 1 shall be $\geq \gamma_1$

For the parameters specified in Table 9.5.3.1-1, and using the downlink physical channels specified in Annex C.3.2, the minimum requirements are specified in Table 9.5.3.1-2.

Table 9.5.3.1-1: RI Test (FDD)

Parameter	Unit	Test 1		Test 2		
		Cell 1	Cell 2	Cell 1	Cell 2	
Bandwidth	MHz	10		10		
PDSCH transmission mode		3	Note 10	3	Note 10	
Downlink power allocation	ρ_A	-3		-3		
	ρ_B	-3		-3		
	σ	0		0		
Propagation condition and antenna configuration		2 x 2 EPA5		2 x 2 EPA5		
CodeBookSubsetRestriction bitmap		01 for fixed RI = 1 10 for fixed RI = 2 11 for UE reported RI	N/A	01 for fixed RI = 1 10 for fixed RI = 2 11 for UE reported RI	N/A	
Antenna correlation		Low		Low		
RI configuration		Fixed RI=1 and follow RI	N/A	Fixed RI=1 and follow RI	N/A	
\hat{E}_s / N_{oc2}	dB	0	-12	20	6	
$N_{oc}^{(j)}$	$N_{oc1}^{(j)}$	dBmW/15kHz	-98 (Note 3)	N/A	-102 (Note 3)	N/A
	$N_{oc2}^{(j)}$		-98 (Note 4)	N/A	-98 (Note 4)	N/A
	$N_{oc3}^{(j)}$		-98 (Note 5)	N/A	-94.8 (Note 5)	N/A
$\hat{I}_{or}^{(j)}$	dB[mW/15k Hz]	-98	-110	-78	-92	
Subframe Configuration		Non-MBSFN	Non-MBSFN	Non-MBSFN	Non-MBSFN	
Cell Id		0	1	0	1	
Time Offset between Cells	μ s	2.5 (synchronous cells)		2.5 (synchronous cells)		
ABS Pattern (Note 6)		N/A	10000000 10000000 10000000 10000000 10000000	N/A	10000000 10000000 10000000 10000000 10000000	
RLM/RRM Measurement Subframe Pattern (Note 7)		10000000 10000000 10000000 10000000 10000000	N/A	10000000 10000000 10000000 10000000 10000000	N/A	
CSI Subframe Sets (Note 8)	$C_{csi,0}$	10000000 10000000 10000000 10000000 10000000	N/A	10000000 10000000 10000000 10000000 10000000	N/A	
	$C_{csi,1}$	01111111 01111111 01111111 01111111 01111111		01111111 01111111 01111111 01111111 01111111		
Number of control OFDM Symbols		3	3	3	3	
Maximum number of HARQ transmissions		1		1		
Reporting mode		PUCCH 1-0		PUCCH 1-0		
Physical channel for CQI reporting		PUCCH Format 2		PUCCH Format 2		
PUCCH Report Type for CQI		4		4		

Physical channel for RI reporting		PUCCH Format 2		PUCCH Format 2	
PUCCH Report Type for RI		3		3	
Reporting periodicity	ms	$N_{pd}= 10$		$N_{pd}= 10$	
<i>cqi-pmi-ConfigurationIndex</i>		11		11	
<i>ri-ConfigurationInd</i>		5		5	
<i>cqi-pmi-ConfigurationIndex2</i>		10		10	
<i>ri-ConfigurationInd2</i>		2		2	
Cyclic prefix		Normal	Normal	Normal	Normal
Note 1:	If the UE reports in an available uplink reporting instance at subframe SF#n based on CQI estimation at a downlink subframe not later than SF#(n-4), this reported wideband CQI cannot be applied at the eNB downlink before SF#(n+4).				
Note 2:	Reference measurement channel in Cell 1 RC.2 FDD according to Table A.4-1 with one sided dynamic OCNG Pattern OP.1 FDD as described in Annex A.5.1.1.				
Note 3:	This noise is applied in OFDM symbols #1, #2, #3, #5, #6, #8, #9, #10,#12, #13 of a subframe overlapping with the aggressor ABS.				
Note 4:	This noise is applied in OFDM symbols #0, #4, #7, #11 of a subframe overlapping with the aggressor ABS.				
Note 5:	This noise is applied in all OFDM symbols of a subframe overlapping with aggressor non-ABS				
Note 6:	ABS pattern as defined in [9].				
Note 7:	Time-domain measurement resource restriction pattern for PCell measurements as defined in [7].				
Note 8:	As configured according to the time-domain measurement resource restriction pattern for CSI measurements defined in [7].				
Note 9:	Cell 1 is the serving cell. Cell 2 is the aggressor cell. The number of the CRS ports in Cell 1 and Cell 2 is the same.				
Note 10:	Downlink physical channel setup in Cell 2 in accordance with Annex C.3.3 applying OCNG pattern as defined in Annex A.5.1.5.				

Table 9.5.3.1-2: Minimum requirement (FDD)

	Test 1	Test 2
γ	0.9	1.05
UE Category	≥ 2	≥ 2

9.5.3.2 TDD

The minimum performance requirement in Table 9.5.3.2-2 is defined as

- a) The ratio of the throughput obtained when transmitting based on UE reported RI and that obtained when transmitting with fixed rank 1 shall be $\geq \gamma_1$.

For the parameters specified in Table 9.5.3.2-1, and using the downlink physical channels specified in Annex C.3.2, the minimum requirements are specified in Table 9.5.3.2-2.

Table 9.5.3.2-1: RI Test (TDD)

Parameter		Unit	Test1		Test2	
			Cell 1	Cell 2	Cell 1	Cell 2
Bandwidth		MHz	10		10	
PDSCH transmission mode			3	Note 11	3	Note 11
Uplink downlink configuration			1		1	
Special subframe configuration			4		4	
Downlink power allocation	ρ_A	dB	-3		-3	
	ρ_B	dB	-3		-3	
	σ	dB	0		0	
Propagation condition and antenna configuration			2 x 2 EPA5		2 x 2 EPA5	
CodeBookSubsetRestriction bitmap			01 for fixed RI = 1 10 for fixed RI = 2 11 for UE reported RI	N/A	01 for fixed RI = 1 10 for fixed RI = 2 11 for UE reported RI	N/A
Antenna correlation			Low		Low	
RI configuration			Fixed RI=1 and follow RI	N/A	Fixed RI=1 and follow RI	N/A
\widehat{E}_s / N_{oc2}		dB	0	-12	20	6
$N_{oc}^{(j)}$	$N_{oc1}^{(j)}$	dB[mW/15k Hz]	-98 (Note 4)	N/A	-102 (Note 4)	N/A
	$N_{oc2}^{(j)}$		-98 (Note 5)	N/A	-98 (Note 5)	N/A
	$N_{oc3}^{(j)}$		-98 (Note 6)	N/A	-94.8 (Note 6)	N/A
$\widehat{I}_{or}^{(j)}$		dB[mW/15k Hz]	-98	-110	-78	-92
Subframe Configuration			Non-MBSFN	Non-MBSFN	Non-MBSFN	Non-MBSFN
Cell Id			0	1	0	1
Time Offset between Cells		μ s	2.5 (synchronous cells)		2.5 (synchronous cells)	
ABS Pattern (Note 7)			N/A	0000000 001 0000000 001	N/A	000000001 000000001
RLM/RRM Measurement Subframe Pattern (Note 8)			00000000 01 00000000 01	N/A	0000000001 0000000001	N/A
CSI Subframe Sets (Note 9)	$C_{CSI,0}$		00000000 01 00000000 01	N/A	0000000001 0000000001	N/A
	$C_{CSI,1}$		11001110 00 11001110 00		1100111000 1100111000	
Number of control OFDM Symbols			3	3	3	3
Maximum number of HARQ transmissions			1		1	
Reporting mode			PUCCH 1-0		PUCCH 1-0	
Physical channel for $C_{CSI,0}$ CQI and RI reporting			PUCCH Format 2		PUCCH Format 2	
PUCCH Report Type for CQI			4		4	

Physical channel for C _{CSI,1} CQI and RI reporting		PUSCH (Note 3)		PUSCH (Note 3)	
PUCCH Report Type for RI		3		3	
Reporting periodicity	ms	N _{pd} = 10		N _{pd} = 10	
ACK/NACK feedback mode		Multiplexing		Multiplexing	
<i>cqi-pmi-ConfigurationIndex</i>		8		8	
<i>ri-ConfigurationInd</i>		5		5	
<i>cqi-pmi-ConfigurationIndex2</i>		9		9	
<i>ri-ConfigurationInd2</i>		0		0	
Cyclic prefix		Normal	Normal	Normal	Normal
Note 1:	If the UE reports in an available uplink reporting instance at subframe SF#n based on CQI estimation at a downlink subframe not later than SF#(n-4), this reported wideband CQI cannot be applied at the eNB downlink before SF#(n+4).				
Note 2:	Reference measurement channel in Cell 1 RC.2 TDD according to Table A.4-1 with one sided dynamic OCNNG Pattern OP.1 TDD as described in Annex A.5.2.1.				
Note 3:	To avoid collisions between RI/CQI reports and HARQ-ACK it is necessary to report them on PUSCH instead of PUCCH. PDCCH DCI format 0 shall be transmitted in downlink SF#4 and #9 to allow periodic RI/CQI to multiplex with the HARQ-ACK on PUSCH in uplink subframe SF#8 and #3.				
Note 4:	This noise is applied in OFDM symbols #1, #2, #3, #5, #6, #8, #9, #10,#12, #13 of a subframe overlapping with the aggressor ABS				
Note 5:	This noise is applied in OFDM symbols #0, #4, #7, #11 of a subframe overlapping with the aggressor ABS.				
Note 6:	This noise is applied in all OFDM symbols of a subframe overlapping with aggressor non-ABS				
Note 7:	ABS pattern as defined in [9].				
Note 8:	Time-domain measurement resource restriction pattern for PCell measurements as defined in [7].				
Note 9:	As configured according to the time-domain measurement resource restriction pattern for CSI measurements defined in [7].				
Note 10:	Cell 1 is the serving cell. Cell 2 is the aggressor cell. The number of the CRS ports in Cell 1 and Cell 2 is the same.				
Note 11:	Downlink physical channel setup in Cell 2 in accordance with Annex C.3.3 applying OCNNG pattern as defined in Annex A.5.2.5.				

Table 9.5.3.2-2: Minimum requirement (TDD)

	Test 1	Test 2
γ	0.9	1.05
UE Category	≥ 2	≥ 2

9.5.4 Minimum requirement (CSI measurements in case two CSI subframe sets are configured and CRS assistance information are configured)

9.5.4.1 FDD

For the parameters specified in Table 9.5.4.1-1, the minimum performance requirement in Table 9.5.4.1-2 is defined as

- The ratio of the throughput obtained when transmitting based on UE reported RI and that obtained when transmitting with fixed rank 1 shall be $\geq \gamma_1$;
- The ratio of the throughput obtained when transmitting based on UE reported RI and that obtained when transmitting with fixed rank 2 shall be $\geq \gamma_2$;

In Table 9.5.4.1-1, Cell 1 is the serving cell, and Cell 2 and Cell 3 are the aggressor cells. The downlink physical channel setup for Cell 1 is according to Annex C.3.2 and for Cell 2 and Cell 3 is according to Annex C.3.3, respectively. The CRS assistance information [7] including Cell 2 and Cell 3 is provided.

Table 9.5.4.1-1: RI Test (FDD)

Parameter		Unit	Cell 1	Cell 2	Cell 3
Bandwidth		MHz	10	10	10
PDSCH transmission mode			3	As defined in Note 1	As defined in Note 1
Downlink power allocation	ρ_A	dB	-3	-3	-3
	ρ_B	dB	-3	-3	-3
	σ	dB	0	N/A	N/A
Propagation condition and antenna configuration			2x2 EPA5 (Note 2)	2x2 EPA5 (Note 2)	2x2 EPA5 (Note 2)
CodeBookSubsetRestriction bitmap			01 for fixed RI = 1 10 for fixed RI = 2 11 for UE reported RI	As defined in Note 1	As defined in Note 1
N_{oc} at antenna port	N_{oc1}	dB[mW/15k Hz]	-98 (Note 3)	N/A	N/A
	N_{oc2}	dB[mW/15k Hz]	-98 (Note 4)	N/A	N/A
	N_{oc3}	dB[mW/15k Hz]	-93 (Note 5)	N/A	N/A
\widehat{E}_s / N_{oc2}		dB	Reference Value in Table 9.5.4.1-2 for each test	12	10
$\widehat{I}_{or}^{(j)}$		dB[mW/15k Hz]	Reference Value in Table 9.5.4.1-2 for each test	-86	-88
Subframe Configuration			Non-MBSFN	Non-MBSFN	Non-MBSFN
Time Offset between Cells		μ s	N/A	3	-1
Frequency shift between Cells		Hz	N/A	300	-100
Cell Id			0	126	1
ABS pattern (Note 6)			N/A	10000000 10000000 10000000 10000000 10000000	10000000 10000000 10000000 10000000 10000000
RLM/RRM Measurement Subframe Pattern (Note 7)			10000000 10000000 10000000 10000000 10000000	N/A	N/A
CSI Subframe Sets (Note 8)	$C_{csi,0}$		10000000 10000000 10000000 10000000 10000000	N/A	N/A
	$C_{csi,1}$		01111111 01111111 01111111 01111111 01111111	N/A	N/A
Number of control OFDM symbols			3	Note 9	Note 9
Maximum number of HARQ transmissions			1	N/A	N/A
Reporting mode			PUCCH 1-0	N/A	N/A
Physical channel for CQI reporting			PUCCH format 2	N/A	N/A
PUCCH Report Type for CQI			4	N/A	N/A
Physical channel for RI reporting			PUCCH Format 2	N/A	N/A
PUCCH Report Type for RI			3	N/A	N/A
Reporting periodicity		ms	$N_{pd} = 10$	N/A	N/A

<i>cqi-pmi-ConfigurationIndex</i>		11	N/A	N/A
<i>ri-ConfigurationInd</i>		5	N/A	N/A
<i>cqi-pmi-ConfigurationIndex2</i>		10	N/A	N/A
<i>ri-ConfigurationInd2</i>		2	N/A	N/A
Cyclic prefix		Normal	Normal	Normal
Note 1:	Downlink physical channel setup in Cell 2 and Cell 3 in accordance with Annex C.3.3 applying OCNG pattern OP.5 FDD as defined in Annex A.5.1.5.			
Note 2:	The propagation conditions for Cell 1, Cell 2 and Cell 3 are statistically independent.			
Note 3:	This noise is applied in OFDM symbols #1, #2, #3, #5, #6, #8, #9, #10, #12, #13 of a subframe overlapping with the aggressor ABS.			
Note 4:	This noise is applied in OFDM symbols #0, #4, #7, #11 of a subframe overlapping with the aggressor ABS.			
Note 5:	This noise is applied in all OFDM symbols of a subframe overlapping with aggressor non-ABS			
Note 6:	ABS pattern as defined in [9]. PDSCH other than SIB1/paging and its associated PDCCH/PCFICH are transmitted in the serving cell subframe when the subframe is overlapped with the ABS subframe of aggressor cell and the subframe is available in the definition of the reference channel.			
Note 7:	Time-domain measurement resource restriction pattern for PCell measurements as defined in [7]			
Note 8:	As configured according to the time-domain measurement resource restriction pattern for CSI measurements defined in [7].			
Note 9:	The number of control OFDM symbols is not available for ABS and is 3 for the subframe indicated by "0" of ABS pattern.			
Note 10:	If the UE reports in an available uplink reporting instance at subframe SF#n based on CQI estimation at a downlink subframe not later than SF#(n-4), this reported wideband CQI cannot be applied at the eNB downlink before SF#(n+4).			
Note 11:	Reference measurement channel in Cell 1 RC.2 FDD according to Table A.4-1 with one sided dynamic OCNG Pattern OP.1 FDD as described in Annex A.5.1.1.			
Note 12:	The number of the CRS ports in Cell1, Cell2 and Cell 3 is the same.			
Note 13:	SIB-1 will not be transmitted in Cell2 and Cell 3 in this test.			

Table 9.5.4.1-2: Minimum requirement (FDD)

	Test 1	Test 2	Test 3
\hat{E}_s / N_{oc2} for Cell 1 (dB)	4	20	20
$\hat{I}_{or}^{(j)}$ for Cell 1 (dB[mW/15kHz])	-94	-78	-78
Antenna correlation	High for Cell 1, low for Cell 2 and Cell 3	Low for Cell 1, Cell 2 and Cell 3	High for Cell 1, low for Cell 2 and Cell 3
γ_1	N/A	1.05	0.9
γ_2	1.05	N/A	N/A
UE Category	≥ 2	≥ 2	≥ 2

9.5.4.2 TDD

For the parameters specified in Table 9.5.4.2-1, the minimum performance requirement in Table 9.5.4.2-2 is defined as

- The ratio of the throughput obtained when transmitting based on UE reported RI and that obtained when transmitting with fixed rank 1 shall be $\geq \gamma_1$;
- The ratio of the throughput obtained when transmitting based on UE reported RI and that obtained when transmitting with fixed rank 2 shall be $\geq \gamma_2$;

In Table 9.5.4.2-1, Cell 1 is the serving cell, and Cell 2 and Cell 3 are the aggressor cells. The downlink physical channel setup for Cell 1 is according to Annex C.3.2 and for Cell 2 and Cell 3 is according to Annex C.3.3, respectively. The CRS assistance information [7] including Cell 2 and Cell 3 is provided.

Table 9.5.4.2-1: RI Test (TDD)

Parameter		Unit	Cell 1	Cell 2	Cell 3
Bandwidth		MHz	10	10	10
PDSCH transmission mode			3	As defined in Note 1	As defined in Note 1
Uplink downlink configuration			1	1	1
Special subframe configuration			4	4	4
Downlink power allocation	ρ_A	dB	-3	-3	-3
	ρ_B	dB	-3	-3	-3
	σ	dB	0	N/A	N/A
Propagation condition and antenna configuration			2x2 EPA5 (Note 2)	2x2 EPA5 (Note 2)	2x2 EPA5 (Note 2)
CodeBookSubsetRestriction bitmap			01 for fixed RI = 1 10 for fixed RI = 2 11 for UE reported RI	As defined in Note 1	As defined in Note 1
N_{oc} at antenna port	N_{oc1}	dB[mW/15k Hz]	-98 (Note 3)	N/A	N/A
	N_{oc2}	dB[mW/15k Hz]	-98 (Note 4)	N/A	N/A
	N_{oc3}	dB[mW/15k Hz]	-93 (Note 5)	N/A	N/A
\hat{E}_s / N_{oc2}		dB	Reference Value in Table 9.5.4.2-2 for each test	12	10
$\hat{I}_{or}^{(j)}$		dB[mW/15k Hz]	Reference Value in Table 9.5.4.2-2 for each test	-86	-88
Subframe Configuration			Non-MBSFN	Non-MBSFN	Non-MBSFN
Time Offset between Cells		μ s	N/A	3	-1
Frequency shift between Cells		Hz	N/A	300	-100
Cell Id			0	126	1
ABS pattern (Note 6)			N/A	000000001 000000001	000000001 000000001
RLM/RRM Measurement Subframe Pattern (Note 7)			000000001 000000001	N/A	N/A
CSI Subframe Sets (Note 8)	$C_{CSI,0}$		000000001 000000001	N/A	N/A
	$C_{CSI,1}$		1100111000 1100111000	N/A	N/A
Number of control OFDM symbols			3	Note 9	Note 9
Maximum number of HARQ transmissions			1	N/A	N/A
Reporting mode			PUCCH 1-0	N/A	N/A
Physical channel for $C_{CSI,0}$ CQI and RI reporting			PUCCH format 2	N/A	N/A
Physical channel for $C_{CSI,1}$ CQI and RI reporting			PUSCH (Note 14)	N/A	N/A
PUCCH Report Type for CQI			4	N/A	N/A
PUCCH Report Type for RI			3	N/A	N/A
Reporting periodicity		ms	$N_{pd}= 10$	N/A	N/A
ACK/NACK feedback mode			Multiplexing	N/A	N/A
$cqi-pmi-ConfigurationIndex$			8	N/A	N/A
$ri-ConfigurationInd$			5	N/A	N/A
$cqi-pmi-ConfigurationIndex2$			9	N/A	N/A
$ri-ConfigurationInd2$			0	N/A	N/A
Cyclic prefix			Normal	Normal	Normal

Note 1:	Downlink physical channel setup in Cell 2 and Cell 3 in accordance with Annex C.3.3 applying OCNB pattern OP.5 TDD as defined in Annex A.5.2.5.
Note 2:	The propagation conditions for Cell 1, Cell 2 and Cell 3 are statistically independent.
Note 3:	This noise is applied in OFDM symbols #1, #2, #3, #5, #6, #8, #9, #10, #12, #13 of a subframe overlapping with the aggressor ABS.
Note 4:	This noise is applied in OFDM symbols #0, #4, #7, #11 of a subframe overlapping with the aggressor ABS.
Note 5:	This noise is applied in all OFDM symbols of a subframe overlapping with aggressor non-ABS
Note 6:	ABS pattern as defined in [9]. PDSCH other than SIB1/paging and its associated PDCCH/PCFICH are transmitted in the serving cell subframe when the subframe is overlapped with the ABS subframe of aggressor cell and the subframe is available in the definition of the reference channel.
Note 7:	Time-domain measurement resource restriction pattern for PCell measurements as defined in [7]
Note 8:	As configured according to the time-domain measurement resource restriction pattern for CSI measurements defined in [7].
Note 9:	The number of control OFDM symbols is not available for ABS and is 3 for the subframe indicated by "0" of ABS pattern.
Note 10:	If the UE reports in an available uplink reporting instance at subframe SF#n based on CQI estimation at a downlink subframe not later than SF#(n-4), this reported wideband CQI cannot be applied at the eNB downlink before SF#(n+4).
Note 11:	Reference measurement channel in Cell 1 RC.2 TDD according to Table A.4-1 with one sided dynamic OCNB Pattern OP.1 TDD as described in Annex A.5.2.1.
Note 12:	The number of the CRS ports in Cell1, Cell2 and Cell 3 is the same.
Note 13:	SIB-1 will not be transmitted in Cell2 and Cell 3 in this test.
Note 14:	To avoid collisions between RI/CQI reports and HARQ-ACK it is necessary to report them on PUSCH instead of PUCCH. PDCCH DCI format 0 shall be transmitted in downlink SF#4 and #9 to allow periodic RI/CQI to multiplex with the HARQ-ACK on PUSCH in uplink subframe SF#8 and #3.

Table 9.5.4-2: Minimum requirement (TDD)

	Test 1	Test 2	Test 3
\hat{E}_s / N_{oc2} for Cell 1 (dB)	4	20	20
$\hat{I}_{or}^{(j)}$ for Cell 1 (dB[mW/15kHz])	-94	-78	-78
Antenna correlation	High for Cell 1, low for Cell 2 and Cell 3	Low for Cell 1, Cell 2 and Cell 3	High for Cell 1, low for Cell 2 and Cell 3
γ_1	N/A	1.05	0.9
γ_2	1.05	N/A	N/A
UE Category	≥ 2	≥ 2	≥ 2

9.5.5 Minimum requirement (with CSI process)

Each CSI process is associated with a CSI-RS resource and a CSI-IM resource as shown in Table 9.5.5-1.

For UE supports one CSI process, CSI process 0 is configured for Test 1 and Test 2, but CSI process 1 is not configured for Test 2. The corresponding γ requirements for Test 1 and Test 2 shall be fulfilled. The requirement on reported RI for CSI process 1 in Test 2 is not applicable.

For UE supports multiple CSI processes, CSI process 0 is configured for Test 1 and CSI processes 0 and 1 are configured for Test 2. The corresponding γ requirements for Test 1 and Test 2 shall be fulfilled, and also the requirement on reported RI for CSI process 1 in Test 2.

Table 9.5.5-1: Configuration of CSI processes

	CSI process 0	CSI process 1
CSI-RS resource	CSI-RS signal 0	CSI-RS signal 1
CSI-IM resource	CSI-IM resource 0	CSI-IM resource 1

9.5.5.1 FDD

The minimum performance requirement in Table 9.5.5.1-2 is defined as

- a) The ratio of the throughput obtained when transmitting based on UE reported RI and that obtained when transmitting with fixed rank 1 shall be $\geq \gamma_1$;
- b) The ratio of the throughput obtained when transmitting based on UE reported RI and that obtained when transmitting with fixed rank 2 shall be $\geq \gamma_2$;
- c) For Test 2, the RI reported for CSI process 1 shall be the same as the most recent RI reported for CSI process 0 if UE is configured with multiple CSI processes.

For the parameters specified in Table 9.5.5.1-1, and using the downlink physical channels specified in Annex C.3.2, the minimum requirements are specified in Table 9.5.5.1-2.

Table 9.5.5.1-1: RI Test (FDD)

Parameter		Unit	Test 1		Test 2	
			TP1	TP2	TP1	TP2
Bandwidth		MHz	10 MHz		10 MHz	
Transmission mode			10	10	10	10
Downlink power allocation	ρ_A	dB	0		0	
	ρ_B	dB	0		0	
	P_c	dB	0	0	0	0
	σ	dB	0		0	
SNR		dB	0	0	20	20
$\hat{I}_{or}^{(j)}$		dB[mW/15kHz]	-98	-98	-78	-78
$N_{oc}^{(j)}$		dB[mW/15kHz]	-98		-98	
Propagation channel			EPA 5 Low	EPA 5 Low	EPA 5 Low	EPA 5 High
Antenna configuration			2x2	2x2	2x2	2x2
Beamforming Model			As specified in Section B.4.3		As specified in Section B.4.3	
Timing offset between TPs		us	0		0	
Frequency offset between TPs		Hz	0		0	
Cell-specific reference signals			Antenna ports 0		Antenna ports 0	
CSI-RS signal 0			Antenna ports 15,16	N/A	Antenna ports 15,16	N/A
CSI-RS 0 periodicity and subframe offset $T_{CSI-RS} / \Delta_{CSI-RS}$			5/1	N/A	5/1	N/A
CSI-RS 0 configuration			0	N/A	0	N/A
CSI-RS signal 1			N/A	Antenna ports 15,16	N/A	Antenna ports 15,16
CSI-RS 1 periodicity and subframe offset $T_{CSI-RS} / \Delta_{CSI-RS}$			N/A	5/1	N/A	5/1
CSI-RS 1 configuration			N/A	3	N/A	3
Zero-power CSI-RS 0 configuration $l_{CSI-RS} / ZeroPowerCSI-RS$ bitmap			N/A	1 / 10000010000 00000	N/A	1] / 10000010000 00000
Zero-power CSI-RS 1 configuration $l_{CSI-RS} / ZeroPowerCSI-RS$ bitmap			1 / 00110000000 00000	N/A	1 / 00110000000 00000	N/A
CSI-IM 0 periodicity and subframe offset $T_{CSI-RS} / \Delta_{CSI-RS}$			5/1	N/A	5/1	N/A
CSI-IM 0 configuration			2	N/A	2	N/A
CSI-IM 1 periodicity and subframe offset $T_{CSI-RS} / \Delta_{CSI-RS}$			N/A	5/1	N/A	5/1
CSI-IM 1 configuration			N/A	6	N/A	6
RI configuration			Fixed RI=2 and follow RI	N/A	Fixed RI=1 and follow RI	N/A
Physical channel for CQI/PMI reporting			PUSCH (Note 6)	N/A	PUSCH (Note 6)	PUSCH (Note 6)
PUCCH Report Type for CQI/PMI			2	N/A	2	2
Physical channel for RI reporting			PUCCH Format 2	N/A	PUCCH Format 2	PUCCH Format 2
PUCCH Report Type for RI			3	N/A	3	3
CSI process 0 (Note 7)	CSI-RS		CSI-RS 0	N/A	CSI-RS 0	N/A
	CSI-IM		CSI-IM 0	N/A	CSI-IM 0	N/A
	Reporting mode		PUCCH 1-1	N/A	PUCCH 1-1	N/A
	Reporting periodicity	ms	$N_{pd} = 5$	N/A	$N_{pd} = 5$	N/A
	CQI delay	ms	8	N/A	10	N/A
	$cqi-pmi-ConfigurationIndex$		6	N/A	6	N/A
	$ri-ConfigIndex$		1	N/A	1	N/A
CSI process 1 (Note 7, Note 9)	CSI-RS		N/A	N/A	N/A	CSI-RS 1
	CSI-IM		N/A	N/A	N/A	CSI-IM 1
	Reporting mode		N/A	N/A	N/A	PUCCH 1-1
	Reporting periodicity	ms	N/A	N/A	N/A	$N_{pd} = 5$

	CQI delay	ms	N/A	N/A	N/A	10
	<i>cqi-pmi-ConfigurationIndex</i>		N/A	N/A	N/A	4
	<i>ri-ConfigIndex</i>		N/A	N/A	N/A	1
CSI process for PDSCH scheduling			CSI process 0		CSI process 0	
Cell ID			0	6	0	6
Quasi-co-located CSI-RS			CSI-RS 0	CSI-RS 1	CSI-RS 0	CSI-RS 1
Quasi-co-located CRS			Same Cell ID as Cell 1	Same Cell ID as Cell 2	Same Cell ID as Cell 1	Same Cell ID as Cell 2
PMI for subframe 2, 3, 4, 7, 8 and 9			010000 for fixed RI = 2 010011 for UE reported RI	100000	000011 for fixed RI = 1 010011 for UE reported RI	N/A
PMI for subframe 1 and 6			100000	100000	100000	N/A
Max number of HARQ transmissions			1	N/A	1	N/A
Note 1:	If the UE reports in an available uplink reporting instance at subframe SF#n based on CQI estimation at a downlink SF not later than SF#(n-4), this reported wideband CQI cannot be applied at the eNB downlink before SF#(n+4)					
Note 2:	3 symbols allocated to PDCCH					
Note 3:	Reference measurement channel RC.13 FDD according to Table A.4-1. PDSCH transmission is scheduled on subframe 2, 3, 4, 7, 8 and 9 from TP1.					
Note 4:	TM10 OCNG as specified in A.5.1.8 is transmitted on subframe 1 and 6 from TP1.					
Note 5:	TM10 OCNG as specified in A.5.1.8 is transmitted on subframe 1, 2, 3, 4, 6, 7, 8 and 9 from TP2 for Test 1; TP2 is blanked for Test 2.					
Note 6:	To avoid collisions between CQI/PMI reports and HARQ-ACK it is necessary to report both on PUSCH instead of PUCCH. PDCCH DCI format 0 shall be transmitted in downlink SF#1 and #6 to allow periodic CQI/PMI to multiplex with the HARQ-ACK on PUSCH in uplink SF#0 and #5.					
Note 7:	If UE supports multiple CSI processes, CSI process 0 is configured as 'RI-reference CSI process' for CSI process 1.					
Note 8:	PDCCH DCI format 0 with a trigger for aperiodic CQI shall be transmitted in downlink SF#1 and #6 to allow aperiodic CQI/PMI/RI to be transmitted in uplink SF#0 and #5.					
Note 9:	If UE supports one CSI process, CSI process 1 is not configured in Test 2.					

Table 9.5.5.1-2: Minimum requirement (FDD)

	Test 1	Test 2
γ_1	N/A	1.0
γ_2	1.0	N/A
UE Category	≥ 2	≥ 2

9.5.5.2 TDD

The minimum performance requirement in Table 9.5.5.2-2 is defined as

- The ratio of the throughput obtained when transmitting based on UE reported RI and that obtained when transmitting with fixed rank 1 shall be $\geq \gamma_1$;
- The ratio of the throughput obtained when transmitting based on UE reported RI and that obtained when transmitting with fixed rank 2 shall be $\geq \gamma_2$;
- For Test 2, the RI reported for CSI process 1 shall be the same as the most recent RI reported for CSI process 0 if UE is configured with multiple CSI processes.

For the parameters specified in Table 9.5.5.2-1, and using the downlink physical channels specified in Annex C.3.2, the minimum requirements are specified in Table 9.5.5.2-2.

Table 9.5.5.2-1: RI Test (TDD)

Parameter		Unit	Test 1		Test 2	
			TP1	TP2	TP1	TP2
Bandwidth		MHz	10 MHz		10 MHz	
Transmission mode			10	10	10	10
Downlink power allocation	ρ_A	dB	0		0	
	ρ_B	dB	0		0	
	P_c	dB	0	0	0	0
	σ	dB	0		0	
Uplink downlink configuration			2	2	2	2
Special subframe configuration			4	4	4	4
SNR		dB	0	0	20	20
$\hat{I}_{or}^{(j)}$		dB[mW/15kHz]	-98	-98	-78	-78
$N_{oc}^{(j)}$		dB[mW/15kHz]	-98		-98	
Propagation channel			EPA 5 Low	EPA 5 Low	EPA 5 Low	EPA 5 High
Antenna configuration			2x2	2x2	2x2	2x2
Beamforming Model			As specified in Section B.4.3		As specified in Section B.4.3	
Timing offset between TPs		us	0		0	
Frequency offset between TPs		Hz	0		0	
Cell-specific reference signals			Antenna ports 0		Antenna ports 0	
CSI-RS signal 0			Antenna ports 15,16	N/A	Antenna ports 15,16	N/A
CSI-RS 0 periodicity and subframe offset $T_{CSI-RS} / \Delta_{CSI-RS}$			5/3	N/A	5/3	N/A
CSI-RS 0 configuration			0	N/A	0	N/A
CSI-RS signal 1			N/A	Antenna ports 15,16	N/A	Antenna ports 15,16
CSI-RS 1 periodicity and subframe offset $T_{CSI-RS} / \Delta_{CSI-RS}$			N/A	5/3	N/A	5/3
CSI-RS 1 configuration			N/A	3	N/A	3
Zero-power CSI-RS 0 configuration $l_{CSI-RS} / ZeroPowerCSI-RS$ bitmap			N/A	3 / 10000010000 00000	N/A	3 / 10000010000 00000
Zero-power CSI-RS 1 configuration $l_{CSI-RS} / ZeroPowerCSI-RS$ bitmap			3 / 00110000000 00000	N/A	3 / 00110000000 00000	N/A
CSI-IM 0 periodicity and subframe offset $T_{CSI-RS} / \Delta_{CSI-RS}$			5/3	N/A	5/3	N/A
CSI-IM 0 configuration			2	N/A	2	N/A
CSI-IM 1 periodicity and subframe offset $T_{CSI-RS} / \Delta_{CSI-RS}$			N/A	5/3	N/A	5/3
CSI-IM 1 configuration			N/A	6	N/A	6
RI configuration			Fixed RI=2 and follow RI	N/A	Fixed RI=1 and follow RI	N/A
CSI process 0 (Note 6, 7)	CSI-RS		CSI-RS 0	N/A	CSI-RS 0	N/A
	CSI-IM		CSI-IM 0	N/A	CSI-IM 0	N/A
	Reporting mode		PUSCH 3-1	N/A	PUSCH 3-1	N/A
	Reporting Interval	ms	5	N/A	5	N/A
CSI process 1 (Note 6, 7, 8)	CQI delay	ms	11	N/A	11	N/A
	CSI-RS		N/A	N/A	N/A	CSI-RS 1
	CSI-IM		N/A	N/A	N/A	CSI-IM 1
	Reporting mode		N/A	N/A	N/A	PUSCH 3-1
Reporting Interval	ms	N/A	N/A	N/A	5	
CQI delay	ms	N/A	N/A	N/A	11	
CSI process for PDSCH scheduling			CSI process 0		CSI process 0	
Cell ID			0	6	0	6
Quasi-co-located CSI-RS			CSI-RS 0	CSI-RS 1	CSI-RS 0	CSI-RS 1
Quasi-co-located CRS			Same Cell ID as Cell 1	Same Cell ID as Cell 2	Same Cell ID as Cell 1	Same Cell ID as Cell 2
PMI for subframe 4 and 9			010000 for fixed RI = 2 010011 for UE	100000	000011 for fixed RI = 1 010011 for UE	N/A

		reported RI		reported RI	
PMI for subframe 3 and 8		100000	100000	100000	N/A
Max number of HARQ transmissions		1	N/A	1	N/A
ACK/NACK feedback mode		Multiplexing	N/A	Multiplexing	N/A
Note 1:	If the UE reports in an available uplink reporting instance at subframe SF#n based on CQI estimation at a downlink SF not later than SF#(n-4), this reported wideband CQI cannot be applied at the eNB downlink before SF#(n+4)				
Note 2:	3 symbols allocated to PDCCH				
Note 3:	Reference measurement channel RC.13 TDD according to Table A.4-1. PDSCH transmission is scheduled on subframe 4 and 9 from TP1.				
Note 4:	TM10 OCNG as specified in A.5.2.8 is transmitted on subframe 3 and 8 from TP1.				
Note 5:	TM10 OCNG as specified in A.5.2.8 is transmitted on subframe 3, 4, 8 and 9 from TP2 for Test 1; TP2 is blanked for Test 2.				
Note 6:	Reported wideband CQI and PMI are used and sub-band CQI is discarded.				
Note 7:	If UE supports multiple CSI processes, CSI process 0 is configured as 'RI-reference CSI process' for CSI process 1.				
Note 8:	If UE supports one CSI process, CSI process 1 is not configured in Test 2.				
Note 9:	PDCCH DCI format 0 with a trigger for aperiodic CQI shall be transmitted in downlink SF#3 and #8 to allow aperiodic CQI/PMI/RI to be transmitted in uplink SF#7 and #2.				

Table 9.5.5.2-2: Minimum requirement (TDD)

	Test 1	Test 2
γ_1	N/A	1.0
γ_2	1.0	N/A
UE Category	≥ 2	≥ 2

9.6 Additional requirements for carrier aggregation

This clause includes requirements for the reporting of channel state information (CSI) with the UE configured for carrier aggregation. The purpose is to verify that the channel state for each cell is correctly reported with multiple cells configured for periodic reporting.

9.6.1 Periodic reporting on multiple cells (Cell-Specific Reference Symbols)

9.6.1.1 FDD

The following requirements apply to UE Category ≥ 3 . For CA with 2 DL CC, for the parameters specified in Table 9.6.1.1-1 and Table 9.6.1.1-2, and using the downlink physical channels specified in tables C.3.2-1 and C.3.2-2 on each cell, the difference between the wideband CQI indices of Pcell and Scell reported shall be such that

$$\text{wideband CQI}_{\text{Pcell}} - \text{wideband CQI}_{\text{Scell}} \geq 2$$

for more than 90% of the time.

Table 9.6.1.1-1: Parameters for PUCCH 1-0 static test on multiple cells (FDD, 2 DL CA)

Parameter	Unit	Pcell	Scell
PDSCH transmission mode			1
Downlink power allocation	ρ_A	dB	0
	ρ_B	dB	0
Propagation condition and antenna configuration		AWGN (1 x 2)	
SNR	dB	10	4
$\hat{I}_{or}^{(j)}$	dB[mW/15kHz]	-88	-94
$N_{oc}^{(j)}$	dB[mW/15kHz]	-98	-98
Physical channel for CQI reporting		PUCCH Format 2	
PUCCH Report Type		4	
Reporting periodicity	ms	$N_{pd} = 10$	
<i>cqi-pmi-ConfigurationIndex</i>		11	16 (shift of 5 ms relative to Pcell)
Note 1: 3 symbols are allocated to PDCCH. No PDSCH for user data is scheduled for the UE with one sided dynamic OCNG Pattern OP.1 FDD as described in Annex A.5.1.1.			

Table 9.6.1.1-2: PUCCH 1-0 static test (FDD, 2 DL CA)

Test number	Bandwidth combination
1	10MHz for both cells
2	20MHz for both cells
3	5MHz for both cells
4	5MHz for PCell and 10MHz for SCell
Note 1: The applicability of requirements for different CA configurations and bandwidth combination sets is defined in 9.1.1.2. The test coverage for different number of component carriers is defined in 9.1.1.3.	
Note 2: Mapping of PCell and SCell to the CCs shall be constant for all the iterations during the test. Each execution of the test shall use the same mapping.	

The following requirements apply to UE Category ≥ 5 . For CA with 3 DL CC, for the parameters specified in Table 9.6.1.1-3 and Table 9.6.1.1-4, and using the downlink physical channels specified in tables C.3.2-1 and C.3.2-2 on each cell, the difference between the wideband CQI indices of PCell and SCell1 reported, and the difference between the wideband CQI indices of SCell 1 and SCell2 reported shall be such that

$$\text{wideband CQI}_{\text{PCell}} - \text{wideband CQI}_{\text{SCell1}} \geq 2$$

$$\text{wideband CQI}_{\text{SCell1}} - \text{wideband CQI}_{\text{SCell2}} \geq 2$$

for more than 90% of the time.

Table 9.6.1.1-3: Parameters for PUCCH 1-0 static test on multiple cells (FDD, 3 DL CA)

Parameter		Unit	Pcell	Scell1	Scell2
PDSCH transmission mode				1	
Downlink power allocation	ρ_A	dB		0	
	ρ_B	dB		0	
Propagation condition and antenna configuration			AWGN (1 x 2)		
SNR		dB	12	6	0
$\hat{I}_{or}^{(j)}$		dB[mW/15kHz]	-86	-92	-98
$N_{oc}^{(j)}$		dB[mW/15kHz]	-98	-98	-98
Physical channel for CQI reporting			PUCCH Format 2		
PUCCH Report Type			4		
Reporting periodicity		ms	$N_{pd} = 20$		
<i>cqi-pmi-ConfigurationIndex</i>			21	26 (shift of 5 ms relative to Pcell)	31 (shift of 10 ms relative to Pcell)
Note 1:	3 symbols are allocated to PDCCH. No PDSCH for user data is scheduled for the UE with one sided dynamic OCNG Pattern OP.1 FDD as described in Annex A.5.1.1.				
Note 2:	Void				

Table 9.6.1.1-4: PUCCH 1-0 static test (FDD, 3 DL CA)

Test number	Bandwidth combination (MHz)
1	3x20
2	20+20+15
3	20+20+10
4	20+15+15
5	20+15+10
6	20+10+10
7	15+15+10
8	20+10+5
Note 1:	The applicability of requirements for different CA configurations and bandwidth combination sets is defined in 9.1.1.2. The test coverage for different number of component carriers is defined in 9.1.1.3.
Note 2:	If more than one cell can be configured as PCell, choose one with the smallest bandwidth as PCell. Mapping of PCell and Scells to the CCs shall be constant for all the iterations during the test. Each execution of the test shall use the same mapping.

9.6.1.2 TDD

The following requirements apply to UE Category ≥ 3 . For CA with 2 DL CC, for the parameters specified in Table 9.6.1.2-1 and Table 9.6.1.2-2, and using the downlink physical channels specified in tables C.3.2-1 and C.3.2-2 on each cell, the difference between the wideband CQI indices of Pcell and Scell reported shall be such that

$$\text{wideband CQI}_{\text{Pcell}} - \text{wideband CQI}_{\text{Scell}} \geq 2$$

for more than 90% of the time.

Table 9.6.1.2-1: PUCCH 1-0 static test on multiple cells (TDD, 2 DL CA)

Parameter		Unit	Pcell	Scell
PDSCH transmission mode				1
Uplink downlink configuration				2
Special subframe configuration				4
Downlink power allocation	ρ_A	dB		0
	ρ_B	dB		0
Propagation condition and antenna configuration			AWGN (1 x 2)	
SNR		dB	10	4
$\hat{I}_{or}^{(j)}$		dB[mW/15kHz]	-88	-94
$N_{oc}^{(j)}$		dB[mW/15kHz]	-98	-98
Physical channel for CQI reporting			PUCCH Format 2	
PUCCH Report Type			4	
Reporting periodicity		ms	$N_{pd} = 10$	
<i>cqi-pmi-ConfigurationIndex</i>			8	13 (shift of 5 ms relative to Pcell)
Note 1:		3 symbols are allocated to PDCCH. No PDSCH for user data is scheduled for the UE with one sided dynamic OCNG Pattern OP.1 TDD as described in Annex A.5.2.1.		
Note 2:		Void		

Table 9.6.1.2-2: PUCCH 1-0 static test (TDD, 2 DL CA)

Test number	Bandwidth combination
1	20MHz for both cells
2	15MHz for PCell and 20MHz for SCell
Note 1: The applicability of requirements for different CA configurations and bandwidth combination sets is defined in 9.1.1.2. The test coverage for different number of component carriers is defined in 9.1.1.3.	

The following requirements apply to UE Category ≥ 5 . For CA with 3 DL CC, for the parameters specified in Table 9.6.1.2-3 and Table 9.6.1.2-4, and using the downlink physical channels specified in tables C.3.2-1 and C.3.2-2 on each cell, the difference between the wideband CQI indices of PCell and SCell1 reported, and the difference between the wideband CQI indices of SCell 1 and SCell2 reported shall be such that

$$\text{wideband CQI}_{\text{PCell}} - \text{wideband CQI}_{\text{SCell1}} \geq 2$$

$$\text{wideband CQI}_{\text{SCell1}} - \text{wideband CQI}_{\text{SCell2}} \geq 2$$

for more than 90% of the time.

Table 9.6.1.2-3: PUCCH 1-0 static test on multiple cells (TDD, 3 DL CA)

Parameter		Unit	Pcell	Scell1	Scell2
PDSCH transmission mode				1	
Uplink downlink configuration				2	
Special subframe configuration				4	
Downlink power allocation	ρ_A	dB		0	
	ρ_B	dB		0	
Propagation condition and antenna configuration			AWGN (1 x 2)		
SNR		dB	12	6	0
$\hat{I}_{or}^{(j)}$		dB[mW/15kHz]	-86	-92	-98
$N_{oc}^{(j)}$		dB[mW/15kHz]	-98	-98	-98
Physical channel for CQI reporting			PUCCH Format 2		
PUCCH Report Type			4		
Reporting periodicity		ms	$N_{pd} = 20$		
<i>cqi-pmi-ConfigurationIndex</i>			18	23 (shift of 5 ms relative to Pcell)	28 (shift of 10 ms relative to Pcell)
Note 1: 3 symbols are allocated to PDCCH. No PDSCH for user data is scheduled for the UE with one sided dynamic OCNB Pattern OP.1 TDD as described in Annex A.5.2.1.					
Note 2: Void					

Table 9.6.1.2-4: PUCCH 1-0 static test (TDD, 3 DL CA)

Test number	Bandwidth combination (MHz)
1	3x20
2	20+20+15
Note 1: The applicability of requirements for different CA configurations and bandwidth combination sets is defined in 9.1.1.2. The test coverage for different number of component carriers is defined in 9.1.1.3.	
Note 2: If more than one cell can be configured as PCell, choose one of the cells with the smallest bandwidth as PCell.	

9.6.1.3 TDD-FDD CA with FDD PCell

The following requirements apply to UE Category ≥ 5 . For TDD-FDD CA with FDD PCell with 2 DL CC, for the parameters specified in Table 9.6.1.3-1 and Table 9.6.1.3-2, and using the downlink physical channels specified in tables C.3.2-1 and C.3.2-2 on each cell, the difference between the wideband CQI indices of PCell and SCell reported shall be such that

$$\text{wideband CQI}_{\text{PCell}} - \text{wideband CQI}_{\text{SCell}} \geq 2$$

for more than 90% of the time.

Table 9.6.1.3-1: Parameters for PUCCH 1-0 static test on multiple cells (TDD-FDD CA with FDD PCell, 2 DL CA)

Parameter		Unit	PCell	SCell
PDSCH transmission mode				1
Uplink downlink configuration			N/A	2
Special subframe configuration			N/A	4
Downlink power allocation	ρ_A	dB	0	
	ρ_B	dB	0	
Propagation condition and antenna configuration			AWGN (1 x 2)	
SNR		dB	10	4
$\hat{I}_{or}^{(j)}$		dB[mW/15kHz]	-88	-94
$N_{oc}^{(j)}$		dB[mW/15kHz]	-98	-98
Physical channel for CQI reporting			PUCCH Format 2	
PUCCH Report Type			4	
Reporting periodicity		ms	$N_{pd} = 10$	
<i>cqi-pmi-ConfigurationIndex</i>			9	14 (shift of 5 ms relative to Pcell)
Note 1:	3 symbols are allocated to PDCCH. No PDSCH for user data is scheduled for the UE with one sided dynamic OCNG Pattern OP.1 FDD and OP.1 TDD as described in Annex A.5.1.1 and A.5.2.1.			
Note 2:	Void			
Note 3:	Void			

Table 9.6.1.3-2: PUCCH 1-0 static test (TDD-FDD CA with FDD PCell, 2 DL CA)

Test number	Bandwidth combination
1	20MHz for FDD cell and 20MHz for TDD cell
2	10MHz for FDD cell and 20MHz for TDD cell
3	15MHz for FDD cell and 20MHz for TDD cell
Note 1:	The applicability of requirements for different CA configurations and bandwidth combination sets is defined in 9.1.1.2A. The test coverage for different number of component carriers is defined in 9.1.1.3.

The following requirements apply to UE Category ≥ 5 . For TDD-FDD CA with FDD PCell with 3 DL CC, for the parameters specified in Table 9.6.1.3-3 and Table 9.6.1.3-4, and using the downlink physical channels specified in tables C.3.2-1 and C.3.2-2 on each cell, the difference between the wideband CQI indices of PCell and SCell1 reported, and the difference between the wideband CQI indices of SCell1 and SCell2 reported shall be such that

$$\text{wideband CQI}_{\text{PCell}} - \text{wideband CQI}_{\text{SCell1}} \geq 2$$

$$\text{wideband CQI}_{\text{SCell1}} - \text{wideband CQI}_{\text{SCell2}} \geq 2$$

for more than 90% of the time.

Table 9.6.1.3-3: PUCCH 1-0 static test on multiple cells (TDD-FDD CA with FDD PCell, 3 DL CA)

Parameter		Unit	PCell	SCell1	SCell2
PDSCH transmission mode				1	
Uplink downlink configuration			N/A	2 if SCell1 is TDD Cell N/A if SCell1 is FDD Cell	2
Special subframe configuration			N/A	4 if SCell1 is TDD Cell N/A if SCell1 is FDD Cell	4
Downlink power allocation	ρ_A	dB	0		
	ρ_B	dB	0		
Propagation condition and antenna configuration			AWGN (1 x 2)		
SNR		dB	12	6	0
$\hat{I}_{or}^{(j)}$		dB[mW/15kHz]	-86	-92	-98
$N_{oc}^{(j)}$		dB[mW/15kHz]	-98	-98	-98
Physical channel for CQI reporting			PUCCH Format 2		
PUCCH Report Type			4		
Reporting periodicity		ms	$N_{pd} = 20$		
<i>cqi-pmi-ConfigurationIndex</i>			19	24 (shift of 5 ms relative to Pcell)	29 (shift of 10 ms relative to Pcell)
Note 1: 3 symbols are allocated to PDCCH. No PDSCH for user data is scheduled for the UE with one sided dynamic OCNB Pattern OP.1 FDD and OP.1 TDD as described in Annex A.5.1.1 and A.5.2.1.					
Note 2: Void					
Note 3: Void					

Table 9.6.1.4-4: PUCCH 1-0 static test (TDD-FDD CA with FDD PCell, 3 DL CA)

Test number	Bandwidth combination (MHz)
1	20MHz for FDD cell and 2x20MHz for TDD cell
2	15MHz for FDD cell and 2x20MHz for TDD cell
3	10MHz for FDD cell and 2x20MHz for TDD cell
Note 1: The applicability of requirements for different CA configurations and bandwidth combination sets is defined in 9.1.1.2A. The test coverage for different number of component carriers is defined in 9.1.1.3.	

9.6.1.4 TDD-FDD CA with TDD PCell

The following requirements apply to UE Category ≥ 5 . For TDD-FDD CA with TDD PCell with 2 DL CC, for the parameters specified in Table 9.6.1.4-1 and Table 9.6.1.4-2, and using the downlink physical channels specified in tables C.3.2-1 and C.3.2-2 on each cell, the difference between the wideband CQI indices of PCell and SCell reported shall be such that

$$\text{wideband CQI}_{\text{PCell}} - \text{wideband CQI}_{\text{SCell}} \geq 2$$

for more than 90% of the time.

Table 9.6.1.4-1: Parameters for PUCCH 1-0 static test on multiple cells (TDD-FDD CA with TDD PCell, 2 DL CA)

Parameter		Unit	PCell	SCell
PDSCH transmission mode				1
Uplink downlink configuration			2	N/A
Special subframe configuration			4	N/A
Downlink power allocation	ρ_A	dB	0	
	ρ_B	dB	0	
Propagation condition and antenna configuration			AWGN (1 x 2)	
SNR		dB	10	4
$\hat{I}_{or}^{(j)}$		dB[mW/15kHz]	-88	-94
$N_{oc}^{(j)}$		dB[mW/15kHz]	-98	-98
Physical channel for CQI reporting			PUCCH Format 2	
PUCCH Report Type			4	
Reporting periodicity		ms	$N_{pd} = 10$	
<i>cqi-pmi-ConfigurationIndex</i>			8	13 (shift of 5 ms relative to Pcell)
Note 1:	3 symbols are allocated to PDCCH. No PDSCH for user data is scheduled for the UE with one sided dynamic OCNG Pattern OP.1 FDD and OP.1 TDD as described in Annex A.5.1.1 and A.5.2.1.			
Note 2:	Void			
Note 3:	Void			

Table 9.6.1.4-2: PUCCH 1-0 static test (TDD-FDD CA with TDD PCell, 2 DL CA)

Test number	Bandwidth combination
1	20MHz for TDD cell and 20MHz for FDD cell
2	20MHz for TDD cell and 10MHz for FDD cell
3	20MHz for TDD cell and 15MHz for FDD cell
Note 1:	The applicability of requirements for different CA configurations and bandwidth combination sets is defined in 9.1.1.2A. The test coverage for different number of component carriers is defined in 9.1.1.3.

The following requirements apply to UE Category ≥ 5 . For TDD-FDD CA with TDD PCell with 3 DL CC, for the parameters specified in Table 9.6.1.4-3 and Table 9.6.1.4-4, and using the downlink physical channels specified in tables C.3.2-1 and C.3.2-2 on each cell, the difference between the wideband CQI indices of PCell and SCell1 reported, and the difference between the wideband CQI indices of SCell1 and SCell2 reported shall be such that

$$\text{wideband CQI}_{\text{PCell}} - \text{wideband CQI}_{\text{SCell1}} \geq 2$$

$$\text{wideband CQI}_{\text{SCell1}} - \text{wideband CQI}_{\text{SCell2}} \geq 2$$

for more than 90% of the time.

Table 9.6.1.4-3: PUCCH 1-0 static test on multiple cells (TDD-FDD CA with TDD PCell, 3 DL CA)

Parameter		Unit	PCell	SCell1	SCell2
PDSCH transmission mode				1	
Uplink downlink configuration			2	2 if SCell1 is TDD Cell N/A if SCell1 is FDD Cell	N/A
Special subframe configuration			4	4 if SCell1 is TDD Cell N/A if SCell1 is FDD Cell	N/A
Downlink power allocation	ρ_A	dB	0		
	ρ_B	dB	0		
Propagation condition and antenna configuration			AWGN (1 x 2)		
SNR		dB	12	6	0
$\hat{I}_{or}^{(j)}$		dB[mW/15kHz]	-86	-92	-98
$N_{oc}^{(j)}$		dB[mW/15kHz]	-98	-98	-98
Physical channel for CQI reporting			PUCCH Format 2		
PUCCH Report Type			4		
Reporting periodicity		ms	$N_{pd} = 20$		
<i>cqi-pmi-ConfigurationIndex</i>			18	23 (shift of 5 ms relative to Pcell)	28 (shift of 10 ms relative to Pcell)
Note 1: 3 symbols are allocated to PDCCH. No PDSCH for user data is scheduled for the UE with one sided dynamic OCN Pattern OP.1 FDD and OP.1 TDD as described in Annex A.5.1.1 and A.5.2.1.					
Note 2: Void					
Note 3: Void					

Table 9.6.1.3-4: PUCCH 1-0 static test (TDD-FDD CA with FDD PCell, 3 DL CA)

Test number	Bandwidth combination (MHz)
1	2x20MHz for TDD cell and 20MHz for FDD cell
2	2x20MHz for TDD cell and 15MHz for FDD cell
3	2x20MHz for TDD cell and 10MHz for FDD cell
Note 1: The applicability of requirements for different CA configurations and bandwidth combination sets is defined in 9.1.1.2A. The test coverage for different number of component carriers is defined in 9.1.1.3.	

9.7 CSI reporting (Single receiver antenna)

The number of receiver antennas N_{RX} assumed for the minimum performance requirement in this clause is 1.

9.7.1 CQI reporting definition under AWGN conditions

9.7.1.1 FDD and half-duplex FDD

The following requirements apply to UE DL Category 0. For the parameters specified in Table 9.7.1.1-1, and using the downlink physical channels specified in tables C.3.2-1 and C.3.2-2, the reported CQI value according to RC.16 FDD in Table A.4-1 shall be in the range of ± 1 of the reported median more than 90% of the time. If the PDSCH BLER using the transport format indicated by median CQI is less than or equal to 0.1, the BLER using the transport format indicated by the (median CQI + 1) shall be greater than 0.1. If the PDSCH BLER using the transport format indicated by the median CQI is greater than 0.1, the BLER using transport format indicated by (median CQI – 1) shall be less than or equal to 0.1.

Table 9.7.1.1-1: PUCCH 1-0 static test (FDD and half-duplex FDD)

Parameter		Unit	Test 1		Test 2	
Bandwidth		MHz	10			
PDSCH transmission mode			1			
Downlink power allocation	ρ_A	dB	0			
	ρ_B	dB	0			
	σ	dB	0			
Propagation condition and antenna configuration			AWGN (1 x 1)			
SNR (Note 2)		dB	0	1	6	7
$\hat{I}_{or}^{(j)}$		dB[mW/15kHz]	-98	-97	-92	-91
$N_{oc}^{(j)}$		dB[mW/15kHz]	-98		-98	
Max number of HARQ transmissions			1			
Physical channel for CQI reporting			PUCCH Format 2			
PUCCH Report Type			4			
Reporting periodicity		ms	$N_{pd} = 40$			
<i>cqi-pmi-ConfigurationIndex</i>			41			
Note 1: Reference measurement channel RC.16 FDD according to Table A.4-1 with one/two sided dynamic OCNG Pattern OP.1/OP.2 FDD as described in Annex A.5.1.1/A.5.1.2.						
Note 2: For each test, the minimum requirements shall be fulfilled for at least one of the two SNR(s) and the respective wanted signal input level.						

9.7.1.2 TDD

The following requirements apply to UE DL Category 0. For the parameters specified in Table 9.7.1.2-1, and using the downlink physical channels specified in tables C.3.2-1 and C.3.2-2, the reported CQI value according to RC.16 TDD in Table A.4-1 shall be in the range of ± 1 of the reported median more than 90% of the time. If the PDSCH BLER using the transport format indicated by median CQI is less than or equal to 0.1, the BLER using the transport format indicated by the (median CQI + 1) shall be greater than 0.1. If the PDSCH BLER using the transport format indicated by the median CQI is greater than 0.1, the BLER using transport format indicated by (median CQI – 1) shall be less than or equal to 0.1.

Table 9.7.1.2-1: PUCCH 1-0 static test (TDD)

Parameter		Unit	Test 1		Test 2	
Bandwidth		MHz			10	
PDSCH transmission mode					1	
Uplink downlink configuration					2	
Special subframe configuration					4	
Downlink power allocation	ρ_A	dB			0	
	ρ_B	dB			0	
	σ	dB			0	
Propagation condition and antenna configuration			AWGN (1 x 1)			
SNR (Note 2)		dB	0	1	6	7
$\hat{I}_{or}^{(j)}$		dB[mW/15kHz]	-98	-97	-92	-91
$N_{oc}^{(j)}$		dB[mW/15kHz]	-98		-98	
Max number of HARQ transmissions			1			
Physical channel for CQI reporting			PUSCH (Note 3)			
PUCCH Report Type			4			
Reporting periodicity		ms	$N_{pd} = 5$			
<i>cqi-pmi-ConfigurationIndex</i>			3			
ACK/NACK feedback mode			Multiplexing			
<p>Note 1: Reference measurement channel RC.16 TDD according to Table A.4-1 with one/two sided dynamic OCNG Pattern OP.1/OP.2 TDD as described in Annex A.5.2.1/A.5.2.2.</p> <p>Note 2: For each test, the minimum requirements shall be fulfilled for at least one of the two SNR(s) and the respective wanted signal input level.</p> <p>Note 3: To avoid collisions between CQI reports and HARQ-ACK it is necessary to report both on PUSCH instead of PUCCH. PDCCH DCI format 0 shall be transmitted in downlink SF#3 and #8 to allow periodic CQI to multiplex with the HARQ-ACK on PUSCH in uplink subframe SF#7 and #2.</p>						

9.7.2 CQI reporting under fading conditions

9.7.2.1 FDD and half-duplex FDD

For the parameters specified in Table 9.7.2.1-1, and using the downlink physical channels specified in Annex C.3.2, the minimum requirements are specified in Table 9.7.2.1-2 and by the following

- a sub-band differential CQI offset level of 0 shall be reported at least α % of the time but less than β % for each sub-band;
- the ratio of the throughput obtained when transmitting on a randomly selected sub-band among the sub-bands with the highest differential CQI offset level the corresponding TBS and that obtained when transmitting the TBS indicated by the reported wideband CQI median on a randomly selected sub-band in set S shall be $\geq \gamma$;
- when transmitting on a randomly selected sub-band among the sub-bands with the highest differential CQI offset level the corresponding TBS, the average BLER for the indicated transport formats shall be greater or equal to 0.05.

The requirements only apply for sub-bands of full size and the random scheduling across the sub-bands is done by selecting a new sub-band in each TTI for FDD and in each available downlink transmission instance for half-duplex FDD.

Table 9.7.2.1-1 Sub-band test for single antenna transmission (FDD and half-duplex FDD)

Parameter		Unit	Test 1		Test 2	
Bandwidth		MHz	10 MHz			
Transmission mode			1 (port 0)			
Downlink power allocation	ρ_A	dB	0			
	ρ_B	dB	0			
	σ	dB	0			
SNR (Note 3)		dB	8	9	13	14
$\hat{I}_{or}^{(j)}$		dB[mW/15kHz]	-90	-89	-85	-84
$N_{oc}^{(j)}$		dB[mW/15kHz]	-98		-98	
Propagation channel			Clause B.2.4 with $\tau_d = 0.45 \mu s$, $a = 1$, $f_D = 5$ Hz			
Antenna configuration			1 x 1			
Reporting interval		ms	8			
CQI delay		ms	8			
Reporting mode			PUSCH 3-0			
Sub-band size		RB	6 (full size)			
Max number of HARQ transmissions			1			
<p>Note 1: If the UE reports in an available uplink reporting instance at subframe SF#n based on CQI estimation at a downlink subframe not later than SF#(n-4), this reported subband or wideband CQI cannot be applied at the eNB downlink before SF#(n+4)</p> <p>Note 2: Reference measurement channel RC.16 FDD according to Table A.4-1 with one/two sided dynamic OCNG Pattern OP.1/2 FDD as described in Annex A.5.1.1/2.</p> <p>Note 3: For each test, the minimum requirements shall be fulfilled for at least one of the two SNR(s) and the respective wanted signal input level.</p>						

Table 9.7.2.1-2 Minimum requirement (FDD and half-duplex FDD)

	Test 1	Test 2
α [%]	2	2
β [%]	55	55
γ	1.1	1.1
UE DL Category	0	0

9.7.2.2 TDD

For the parameters specified in Table 9.7.2.2-1, and using the downlink physical channels specified in Annex C.3.2, the minimum requirements are specified in Table 9.7.2.2-2 and by the following

- a sub-band differential CQI offset level of 0 shall be reported at least α % of the time but less than β % for each sub-band;
- the ratio of the throughput obtained when transmitting on a randomly selected sub-band among the sub-bands with the highest differential CQI offset level the corresponding TBS and that obtained when transmitting the TBS indicated by the reported wideband CQI median on a randomly selected sub-band in set S shall be $\geq \gamma$;
- when transmitting on a randomly selected sub-band among the sub-bands with the highest differential CQI offset level the corresponding TBS, the average BLER for the indicated transport formats shall be greater or equal to 0.05.

The requirements only apply for sub-bands of full size and the random scheduling across the sub-bands is done by selecting a new sub-band in each available downlink transmission instance for TDD.

Table 9.7.2.2-1 Sub-band test for single antenna transmission (TDD)

Parameter		Unit	Test 1		Test 2	
Bandwidth		MHz	10 MHz			
Transmission mode			1 (port 0)			
Downlink power allocation	ρ_A	dB	0			
	ρ_B	dB	0			
	σ	dB	0			
Uplink downlink configuration			2			
Special subframe configuration			4			
SNR (Note 3)		dB	8	9	13	14
$\hat{I}_{or}^{(j)}$		dB[mW/15kHz]	-90	-89	-85	-84
$N_{oc}^{(j)}$		dB[mW/15kHz]	-98		-98	
Propagation channel			Clause B.2.4 with $\tau_d = 0.45 \mu\text{s}$, $a = 1$, $f_D = 5 \text{ Hz}$			
Antenna configuration			1 x 1			
Reporting interval		ms	5			
CQI delay		ms	10 or 11			
Reporting mode			PUSCH 3-0			
Sub-band size		RB	6 (full size)			
Max number of HARQ transmissions			1			
ACK/NACK feedback mode			Multiplexing			
<p>Note 1: If the UE reports in an available uplink reporting instance at subframe SF#n based on CQI estimation at a downlink subframe not later than SF#(n-4), this reported subband or wideband CQI cannot be applied at the eNB downlink before SF#(n+4)</p> <p>Note 2: Reference measurement channel RC.16 TDD according to Table A.4-1 with one/two sided dynamic OCNG Pattern OP.1/2 TDD as described in Annex A.5.2.1/2.</p> <p>Note 3: For each test, the minimum requirements shall be fulfilled for at least one of the two SNR(s) and the respective wanted signal input level.</p>						

Table 9.7.2.2-2 Minimum requirement (TDD)

	Test 1	Test 2
α [%]	2	2
β [%]	55	55
γ	1.1	1.1
UE DL Category	0	0

10 Performance requirement (MBMS)

10.1 FDD (Fixed Reference Channel)

The parameters specified in Table 10.1-1 are valid for all FDD tests unless otherwise stated. For the requirements defined in this section, the difference between CRS EPRE and the MBSFN RS EPRE should be set to 0 dB as the UE demodulation performance might be different when this condition is not met (e.g. in scenarios where power offsets are present, such as scenarios when reserved cells are present).

Table 10.1-1: Common Test Parameters (FDD)

Parameter	Unit	Value
Number of HARQ processes	Processes	None
Subcarrier spacing	kHz	15 kHz
Allocated subframes per Radio Frame (Note 1)		6 subframes
Number of OFDM symbols for PDCCH		2
Cyclic Prefix		Extended
Note1: For FDD mode, up to 6 subframes (#1/2/3/6/7/8) are available for MBMS, in line with TS 36.331.		

10.1.1 Minimum requirement

The receive characteristic of MBMS is determined by the BLER. The requirement is valid for all RRC states for which the UE has capabilities for MBMS.

For the parameters specified in Table 10.1-1 and Table 10.1.1-1 and Annex A.3.8.1, the average downlink SNR shall be below the specified value for the BLER shown in Table 10.1.1-2.

Table 10.1.1-1: Test Parameters for Testing

Parameter	Unit	Test 1-4	
Downlink power allocation	ρ_A	dB	0
	ρ_B	dB	0 (Note 1)
	σ	dB	0
N_{oc} at antenna port	dBm/15kHz	-98	
Note 1: $P_B = 0$.			

Table 10.1.1-2: Minimum performance

Test number	Bandwidth	Reference Channel	OCNG Pattern	Propagation condition	Correlation Matrix and antenna	Reference value		MBMS UE Category
						BLER (%)	SNR(dB)	
1	10 MHz	R.37 FDD	OP.4 FDD	MBSFN channel model (Table B.2.6-1)	1x2 low	1	4.1	≥ 1
2	10 MHz	R.38 FDD	OP.4 FDD				11.0	≥ 1
3	10 MHz	R.39 FDD	OP.4 FDD				20.1	≥ 2
	5.0MHz	R.39-1 FDD	OP.4 FDD				20.5	1

10.2 TDD (Fixed Reference Channel)

The parameters specified in Table 10.2-1 are valid for all TDD tests unless otherwise stated. For the requirements defined in this section, the difference between CRS EPRE and the MBSFN RS EPRE should be set to 0 dB as the UE demodulation performance might be different when this condition is not met (e.g. in scenarios where power offsets are present, such as scenarios when reserved cells are present).

Table 10.2-1: Common Test Parameters (TDD)

Parameter	Unit	Value
Number of HARQ processes	Processes	None
Subcarrier spacing	kHz	15 kHz
Allocated subframes per Radio Frame (Note 1)		5 subframes
Number of OFDM symbols for PDCCH		2
Cyclic Prefix		Extended
Note1: For TDD mode, in line with TS 36.331, Uplink-Downlink Configuration 5 is proposed, up to 5 subframes (#3/4/7/8/9) are available for MBMS.		

10.2.1 Minimum requirement

The receive characteristic of MBMS is determined by the BLER. The requirement is valid for all RRC states for which the UE has capabilities for MBMS.

For the parameters specified in Table 10.2-1 and Table 10.2.1-1 and Annex A.3.8.2, the average downlink SNR shall be below the specified value for the BLER shown in Table 10.2.1-2.

Table 10.2.1-1: Test Parameters for Testing

Parameter	Unit	Test 1-4	
Downlink power allocation	ρ_A	dB	0
	ρ_B	dB	0 (Note 1)
	σ	dB	0
N_{oc} at antenna port	dBm/15kHz	-98	
Note 1: $P_B = 0$.			

Table 10.2.1-2: Minimum performance

Test number	Bandwidth	Reference Channel	OCNG Pattern	Propagation condition	Correlation Matrix and antenna	Reference value		MBMS UE Category
						BLER (%)	SNR(dB)	
1	10 MHz	R.37 TDD	OP.4 TDD	MBSFN channel model (Table B.2.6-1)	1x2 low	1	3.4	≥ 1
2	10 MHz	R.38 TDD	OP.4 TDD				11.1	≥ 1
3a	10 MHz	R.39 TDD	OP.4 TDD				20.1	≥ 2
3b	5MHz	R.39-1 TDD	OP.4 TDD				20.5	1

11 Performance requirement (ProSe Direct Discovery)

This clause contains the performance requirements for the Sidelink physical channels specified for ProSe Direct Discovery.

11.1 General

11.1.1 Applicability of requirements

The requirements in this clause are applicable to UEs that support ProSe Direct Discovery. Some of the tests defined in this clause are applicable only to UEs that additionally support transmission and reception of Sidelink synchronization signal (indicated using *disc-SLSS*). The test case applicability is in according to table 11.1.1-1 depending on UE capability.

Table 11.1.1-1: ProSe Direct Discovery test applicability

	ProSe Direct Discovery without support of SLSS	ProSe Direct Discovery with support of SLSS
FDD	11.2.1, 11.3.1, 11.5.1	11.3.1, 11.4.1, 11.5.1
TDD	11.2.2, 11.3.2, 11.5.2	11.2.2, 11.3.2, 11.5.2

For maximum Sidelink Processes test specified in clause 11.5, the UE is required to only meet the test for the maximum channel bandwidth over the ProSe operating bands supported by the UE.

11.1.2 Reference DRX configuration

Table 11.1.2-1: Reference DRX configuration

Parameter	Value	Comments
onDurationTimer	psf1	
drx-InactivityTimer	psf1	
drx-RetransmissionTimer	psf1	
longDRX-CycleStartOffset	sf2560, 0	
shortDRX	disabled	
NOTE: For further information see clause 6.3.2 in TS 36.331.		

11.2 Demodulation of PSDCH (single link performance)

The purpose of the requirements in this subclause is to verify the PSDCH demodulation performance with a single active PSDCH link under different operating scenarios and channel conditions.

The active cell(s), when present, are specified in the test parameters specific to the test.

11.2.1 FDD

The minimum requirements are specified in Table 11.2.1-2 with the test parameters specified in Table 11.2.1-1. The receiver UE under test is associated with Cell 1.

Table 11.2.1-1: Test Parameters

Parameter		Unit	Test 1	
Discovery resource pool configuration			As specified in Table A.7.1.1-1 (Configuration #1-FDD)	
DRX configuration			As specified in Table 11.1.2-1	
N_{oc} at antenna port (NOTE 3)		dBm/15kHz	-98	
Active cell(s)			Cell 1 (Serving cell)	
Cell 1	Cyclic prefix		Normal	
	Cell ID		0	
	Downlink power allocation	ρ_A	dB	0
		ρ_B	dB	0 (NOTE 1)
		σ	dB	0
	OCNG Pattern (NOTE 2)			OP.1 FDD
	Propagation channel			AWGN
	Antenna configuration			1x2
RSRP		dBm/15kHz	-92	
Active Sidelink UE(s)			Sidelink UE 1	
Sidelink UE 1	Sidelink Transmissions		PSDCH	
	PSDCH RB allocation		PRB pairs $\{2i, 2i+1\}$, where i is chosen randomly uniformly from $[0,11]$ in each discovery period.	
	Time offset (NOTE 4)		μ s	+1
	Frequency offset (NOTE 5)		Hz	+200
	Propagation Channel			EPA5
	Antenna configuration			1x2 Low
NOTE 1: $P_B = 0$.				
NOTE 2: OCNG is used to fully allocate the available resource blocks to virtual UEs.				
NOTE 3: Applicable to both DL channel and ProSe Direct Discovery Subframes on UL.				
NOTE 4: Time offset of Sidelink UE receive signal with respect to Cell 1 downlink timing at the tested UE.				
NOTE 5: Frequency offset of Sidelink UE with respect to Cell 1 uplink frequency.				

Table 11.2.1-2: Minimum performance

Test num.	Sidelink UE	Band-width	Reference channel	Reference value	
				BLER of PSDCH (%)	SNR (dB)
1	1	5 MHz	D.1 FDD	30	4.6

11.2.2 TDD

The minimum requirements are specified in Table 11.2.2-2 with the test parameters specified in Table 11.2.2-1. The receiver UE under test is associated with Cell 1.

Table 11.2.2-1: Test Parameters

Parameter		Unit	Test 1	
Discovery resource pool configuration			As specified in Table A.7.1.2-1 (Configuration #1-TDD)	
DRX configuration			As specified in Table 11.1.2-1	
N_{oc} at antenna port (NOTE 5)		dBm/15kHz	-98	
Active cell(s)			Cell 1 (Serving cell)	
Cell 1	Cyclic prefix		Normal	
	Uplink downlink configuration (NOTE 3)		0	
	Special subframe configuration (NOTE 4)		4	
	Cell ID		0	
	Downlink power allocation	ρ_A	dB	0
		ρ_B	dB	0 (NOTE 1)
		σ	dB	0
	OCNG Pattern ^{NOTE 2}		OP.1 TDD	
	Propagation channel		AWGN	
	Antenna configuration		1x2	
RSRP	dBm/15kHz	-92		
Active Sidelink UE(s)			Sidelink UE 1	
Sidelink UE 1	Sidelink Transmissions		PSDCH	
	RB allocation		PRB pairs $\{2i, 2i+1\}$, where i is chosen randomly uniformly from $[0,11]$ in each discovery period.	
	Time offset (NOTE 6)	μ s	+1	
	Frequency offset (NOTE 7)	Hz	+200	
	Propagation Channel		EPA5	
	Antenna configuration		1x2 Low	
NOTE 1: $P_B = 0$.				
NOTE 2: OCNG is used to fully allocate the available resource blocks to virtual UEs.				
NOTE 3: As specified in Table 4.2-2 in TS 36.211 [4].				
NOTE 4: As specified in Table 4.2-1 in TS 36.211 [4].				
NOTE 5: Applicable to both DL subframes and UL subframes configured for ProSe Direct Discovery.				
NOTE 6: Time offset of Sidelink UE receive signal with respect to Cell 1 downlink timing at the tested UE.				
NOTE 7: Frequency offset of Sidelink UE with respect to Cell 1 uplink frequency.				

Table 11.2.2-2: Minimum performance

Test num.	Sidelink UE	Band-width	Reference channel	Reference value	
				BLER of PSDCH (%)	SNR (dB)
1	1	5 MHz	D.1 TDD	30	4.6

11.3 Power imbalance performance with two links

The purpose of this test is to check the demodulation performance when receiving PSDCH transmissions from two Sidelink UEs with power imbalance in one subframe.

11.3.1 FDD

The minimum requirements are specified in Table 11.3.1-2 with the test parameters specified in Table 11.3.1-1. The receiver UE under test is associated with Cell 1. The Sidelink UE 1 and 2 are synchronized to Cell 1 and transmit PSDCH on adjacent RBs.

Table 11.3.1-1: Test Parameters

Parameter		Unit	Test 1	
Discovery resource pool configuration			As specified in Table A.7.1.1-1 (Configuration #1-FDD)	
DRX configuration			As specified in Table 11.1.2-1	
N_{oc} at antenna port (NOTE 3)		dBm/15kHz	-98	
Active cell(s)			Cell 1 (Serving cell)	
Cell 1	Cyclic prefix		Normal	
	Cell ID		0	
	Downlink power allocation	ρ_A	dB	0
		ρ_B	dB	0 (NOTE 1)
		σ	dB	0
	OCNG Pattern (NOTE 2)			OP.1 FDD
	Propagation channel			AWGN
	Antenna configuration			1x2
RSRP		dBm/15kHz	-92	
Active Sidelink UE(s)			Sidelink UE 1, Sidelink UE 2	
Sidelink UE 1	Sidelink Transmissions		PSDCH	
	PSDCH RB allocation		PRB pairs {4, 5}	
	Time offset (NOTE 3)		μ s	0
	Frequency offset (NOTE 4)		Hz	0
	Propagation Channel			AWGN
	Antenna configuration			1x2 Low
Sidelink UE 2	Sidelink Transmissions		PSDCH	
	PSDCH RB allocation		PRB pairs {6, 7}	
	Time offset (w.r.t. Cell 1 DL)		μ s	0
	Frequency offset (w.r.t. Cell 1 UL)		Hz	0
	Propagation Channel			AWGN
	Antenna configuration			1x2 Low
Applicability to UEs supporting			Discovery	
NOTE 1: $P_B = 0$.				
NOTE 2: OCNG is used to fully allocate the available resource blocks to virtual UEs.				
NOTE 3: Applicable to both DL channel and ProSe Direct Discovery Subframes on UL.				
NOTE 4: Time offset of Sidelink UE receive signal with respect to Cell 1 downlink timing at the tested UE.				
NOTE 5: Frequency offset of Sidelink UE with respect to Cell 1 uplink frequency.				

Table 11.3.1-2: Minimum performance

Test num.	Band-width	Sidelink UE	Reference channel	Reference value	
				BLER of PSDCH (%)	SNR (dB)
1	5 MHz	1	D.1 FDD	(NOTE 1)	24.3
		2	D.1 FDD	30	6.9

NOTE 1: There is no BLER requirement for Sidelink UE 1.

11.3.2 TDD

The minimum requirements are specified in Table 11.3.2-2 with the test parameters specified in Table 11.3.2-1. The receiver UE under test is associated with Cell 1. The Sidelink UE 1 and 2 are synchronized to Cell 1 and transmit PSDCH on adjacent RBs.

Table 11.3.2-1: Test Parameters

Parameter		Unit	Test 1	
Discovery resource pool configuration			As specified in Table A.7.1.2-1 (Configuration #1-TDD)	
DRX configuration			As specified in Table 11.1.2-1	
N_{oc} at antenna port (NOTE 5)		dBm/15kHz	-98	
Active cell(s)			Cell 1 (Serving cell)	
Cell 1	Cyclic prefix		Normal	
	Uplink downlink configuration (NOTE 3)		0	
	Special subframe configuration (NOTE 4)		4	
	Cell ID		0	
	Downlink power allocation	ρ_A	dB	0
		ρ_B	dB	0 (NOTE 1)
		σ	dB	0
	OCNG Pattern ^{NOTE 2}		OP.1 TDD	
	Propagation channel		AWGN	
	Antenna configuration		1x2	
RSRP	dBm/15kHz	-92		
Active Sidelink UE(s)			Sidelink UE 1, Sidelink UE 2	
Sidelink UE 1	Sidelink Transmissions		PSDCH	
	PSDCH RB allocation		PRB pairs {4, 5}	
	Time offset (NOTE 6)	μ s	0	
	Frequency offset (NOTE 7)	Hz	0	
	Propagation Channel		AWGN	
	Antenna configuration		1x2 Low	
Sidelink UE 2	Sidelink Transmissions		PSDCH	
	RB allocation		PRB pairs {6, 7}	
	Time offset (NOTE 6)	μ s	0	
	Frequency offset (NOTE 7)	Hz	0	
	Propagation Channel		AWGN	
	Antenna configuration		1x2 Low	
NOTE 1: $P_B = 0$.				
NOTE 2: OCNG is used to fully allocate the available resource blocks to virtual UEs.				
NOTE 3: As specified in Table 4.2-2 in TS 36.211 [4].				
NOTE 4: As specified in Table 4.2-1 in TS 36.211 [4].				
NOTE 5: Applicable to both DL subframes and UL subframes configured for ProSe Direct Discovery.				
NOTE 6: Time offset of Sidelink UE receive signal with respect to Cell 1 downlink timing at the tested UE.				
NOTE 7: Frequency offset of Sidelink UE with respect to Cell 1 uplink frequency.				

Table 11.3.2-2: Minimum performance

Test num.	Band-width	Sidelink UE	Reference channel	Reference value	
				BLER of PSDCH (%)	SNR (dB)
1	5 MHz	1	D.1 TDD	(NOTE 1)	24.3
		2	D.1 TDD	30	6.9
NOTE 1: There is no BLER requirement for Sidelink UE 1.					

11.4 Multiple timing reference test

The purpose of this test is to check the demodulation performance when receiving from two Sidelink UEs that follow different timing references and transmitting on different resources (non-overlapping in time).

11.4.1 FDD

The test parameters are specified in Table 11.4.1-1. Sidelink UE 2 and the receiver UE under test are associated with Cell 1. Sidelink UE 1 and 3 are associated with another cell and use a different timing, and UE 1 acts as a synchronization reference. The minimum requirements are specified in Table 11.4.1-2.

Table 11.4.1-1: Test Parameters

Parameter		Unit	Test 1	
Discovery resource pool configuration			As specified in Table A.7.1.1-2 (Configuration #2-FDD)	
DRX configuration			As specified in Table 11.1.2-1	
N_{oc} at antenna port (NOTE 3)		dBm/15kHz	-98	
Active cell(s)			Cell 1 (Serving cell)	
Cell 1	Cyclic prefix		Normal	
	Cell ID		0	
	Downlink power allocation	ρ_A	dB	0
		ρ_B	dB	0 (NOTE 1)
		σ	dB	0
	OCNG Pattern ^{NOTE 2}		OP.1 FDD	
	Propagation channel		AWGN	
	Antenna configuration		1x2	
RSRP	dBm/15kHz	-92		
Active Sidelink UE(s)			Sidelink UEs 1, 2, 3	
Sidelink UE 1	Sidelink Transmissions		SLSS	
	networkControlledSyncTx		ON	
	slssid		30	
	Time offset (NOTE 4)	μ s	3511	
	Frequency offset (NOTE 5)	Hz	-100	
	Propagation channel		EPA5	
	Antenna configuration		1x2 Low	
	\widehat{E}_s of SLSS at antenna port	dBm/15kHz	-82	
Sidelink UE 2	Sidelink Transmissions		PSDCH	
	Resource pool used for transmissions		<i>discRxPool(0)</i>	
	RB allocation		PRB pairs $\{2i, 2i+1\}$, where i is chosen randomly uniformly from $[0, 11]$ in each discovery period.	
	Time offset (NOTE 4)	μ s	+1	
	Frequency offset (NOTE 5)	Hz	+200	
	Propagation Channel		EPA5	
	Antenna configuration		1x2 Low	
Sidelink UE 3	Sidelink Transmissions		PSDCH	
	Resource pool used for transmissions		<i>discRxPool(1)</i>	
	RB allocation		PRB pairs $\{2i, 2i+1\}$, where i is chosen randomly uniformly from $[0, 11]$ in each discovery period.	
	Time offset (NOTE 4)	μ s	3511	
	Frequency offset (NOTE 5)	Hz	+300	
	Propagation Channel		EPA5	
Antenna configuration		1x2 Low		
NOTE 1: $P_B = 0$.				
NOTE 2: OCNG is used to fully allocate the available resource blocks to virtual UEs.				
NOTE 3: Applicable to both DL channel and ProSe Direct Discovery Subframes on UL.				
NOTE 4: Time offset of Sidelink UE receive signal with respect to Cell 1 downlink timing at the tested UE.				
NOTE 5: Frequency offset of Sidelink UE with respect to Cell 1 uplink frequency.				

Table 11.4.1-2: Minimum performance

Test num.	Band-width	Sidelink UE	Reference channel	Reference value	
				BLER of PSDCH (%) ^{NOTE 1}	SNR (dB)
1	5 MHz	2	D.1 FDD	30	4.6
		3	D.1 FDD	30	4.6

NOTE 1: The BLER is measured after 5 D2D Discovery periods (1600 frames) of lead time during which the test UE detects and synchronizes to Sidelink UE 1 SLSS.

11.5 Maximum Sidelink processes test

The purpose of this test is to verify the maximum number of Sidelink processes supported by the UE as reported using UE capability signalling (*discSupportedProc*).

The UE is required to meet only the test for the maximum channel bandwidth over the ProSe operating bands supported by the UE.

11.5.1 FDD

The test parameters are specified in Table 11.5.1-1. Multiple discovery resource pools are interleaved. Each Sidelink UE transmits in one of the resource pools with 3 retransmissions. The minimum requirements are specified in Table 11.5.1-2.

Table 11.5.1-1: Test Parameters

Parameter		Unit	Test 1-7	
Discovery resource pool configuration			As specified in Table A.7.1.1-3 (Configuration #3-FDD) with parameters $BW_{Channel}$, N_{Pools} = Number of configured resource pools (as specified in Table 11.5.1-2), and $N = discSupportedProc$	
DRX configuration			As specified in Table 11.1.2-1	
Active cell(s)			Cell 1 (Serving cell)	
Cell 1	Cyclic prefix		Normal	
	Cell ID		0	
	Downlink power allocation	ρ_A	dB	0
		ρ_B	dB	0 (NOTE 1)
		σ	dB	0
	OCNG Pattern <small>NOTE 2</small>		OP.1 FDD	
	Propagation channel		Static propagation condition No external noise sources are applied	
	Antenna configuration		1x2	
RSRP	dBm/15kHz	-85		
Active Sidelink UE(s)			Sidelink UE i , $i = 0, \dots, discSupportedProc-1$	
Sidelink UE i	Sidelink Transmissions		PSDCH (D.1 FDD)	
	Resource pool index (NOTE 3)		$\lfloor \frac{i}{N_{MAX_SF}} \rfloor$	
	PSDCH RB allocation (NOTE 3)		PRB pairs $\{2*(i \% N_{MAX_SF}), 2*(i \% N_{MAX_SF})+1\}$	
	Time offset (NOTE 4)	μs	0	
	Frequency offset (NOTE 5)	Hz	0	
	Propagation Channel		Static propagation condition No external noise sources are applied	
	Antenna configuration		1x2 Low	
NOTE 1: $P_b = 0$.				
NOTE 2: OCNG is used to fully allocate the available resource blocks to virtual UEs..				
NOTE 3: N_{MAX_SF} represents the maximum number of Sidelink UEs transmitting in one subframe. $N_{MAX_SF} = 12$ (5 MHz), 25 (10MHz), 37 (15MHz), 50 (10MHz).				
NOTE 4: Time offset of Sidelink UE receive signal with respect to Cell 1 downlink timing at the tested UE.				
NOTE 5: Frequency offset of Sidelink UE with respect to Cell 1 uplink frequency.				

Table 11.5.1-2: Minimum performance

Test num.	Bandwidth	discSupportedProc	Number of configured resource pools	\hat{E}_s at antenna port (dBm/15kHz)	Reference value for Sidelink UE $i=0\dots discSupportedProc-1$
					Fraction of maximum throughput (%)
1	5 MHz	50	5	-85	95
2	10 MHz	50	2	-85	95
3	15 MHz	50	2	-85	95
4	20 MHz	50	1	-85	95
5	10 MHz	400	16	-85	95
6	15 MHz	400	11	-85	95
7	20 MHz	400	8	-85	95

11.5.2 TDD

The test parameters are specified in Table 11.5.2-1. Multiple discovery resource pools are interleaved. Each Sidelink UE transmits in one of the resource pools with 3 retransmissions. The minimum requirements are specified in Table 11.5.2-2.

Table 11.5.2-1: Test Parameters

Parameter		Unit	Test 1-7	
Discovery resource pool configuration			As specified in Table A.7.1.2-2 (Configuration #2-TDD) with parameters $BW_{Channel}$, N_{Pools} = Number of configured resource pools (as specified in Table 11.5.2-2), and $N = discSupportedProc$	
DRX configuration			As specified in Table 11.1.2-1	
Active cell(s)			Cell 1 (Serving cell)	
Cell 1	Cyclic prefix		Normal	
	Uplink downlink configuration (NOTE 3)		0	
	Special subframe configuration (NOTE 4)		4	
	Cell ID		0	
	Downlink power allocation	ρ_A	dB	0
		ρ_B	dB	0 (NOTE 1)
		σ	dB	0
	OCNG Pattern ^{NOTE 2}		OP.1 TDD	
	Propagation channel		Static propagation condition No external noise sources are applied	
	Antenna configuration		1x2	
RSRP	dBm/15kHz	-85		
Active Sidelink UE(s)			Sidelink UE i , $i = 0, \dots, discSupportedProc-1$	
Sidelink UE i	Sidelink Transmissions		PSDCH (D.1 TDD)	
	PSDCH Resource pool (NOTE 5)		$\lfloor \frac{i}{N_{MAX_SF}} \rfloor$	
	PSDCH RB allocation (NOTE 5)		PRB pairs $\{2*(i \% N_{MAX_SF}), 2*(i \% N_{MAX_SF})+1\}$	
	Time offset (NOTE 6)	μs	0	
	Frequency offset (NOTE 7)	Hz	0	
	Propagation Channel		Static propagation condition No external noise sources are applied	
	Antenna configuration		1x2 Low	
<p>NOTE 1: $P_B = 0$.</p> <p>NOTE 2: OCNG is used to fully allocate the available resource blocks to virtual UEs.</p> <p>NOTE 3: As specified in Table 4.2-2 in TS 36.211 [4].</p> <p>NOTE 4: As specified in Table 4.2-1 in TS 36.211 [4].</p> <p>NOTE 5: N_{MAX_SF} represents the maximum number of Sidelink UEs transmitting in one subframe. $N_{MAX_SF} = 12$ (5 MHz), 25 (10MHz), 37 (15MHz), 50 (10MHz).</p> <p>NOTE 6: Time offset of Sidelink UE receive signal with respect to Cell 1 downlink timing at the tested UE.</p> <p>NOTE 7: Frequency offset of Sidelink UE with respect to Cell 1 uplink frequency.</p>				

Table 11.5.2-2: Minimum performance

Test num.	Bandwidth	discSupportedProc	Number of configured resource pools	\hat{E}_s at antenna port (dBm/15kHz)	Reference value
					Fraction of maximum throughput (%) for Sidelink UE $i=0\dots\text{discSupportedProc}-1$
1	5 MHz	50	5	-85	95
2	10 MHz	50	2	-85	95
3	15 MHz	50	2	-85	95
4	20 MHz	50	1	-85	95
5	10 MHz	400	16	-85	95
6	15 MHz	400	11	-85	95
7	20 MHz	400	8	-85	95

12 Performance requirement (ProSe Direct Communication)

This clause contains the performance requirements for the Sidelink physical channels specified for ProSe Direct Communication in TS 36.211 [4].

12.1 General

12.1.1 Applicability of requirements

The requirements in this clause are applicable to UEs that support ProSe Direct Communication. Test cases defined for 5MHz channel bandwidth are applicable to UEs that support ProSe Direct Communication on only Band 31.

12.1.2 Reference DRX configuration

Table 12.1.2-1: Reference DRX configuration

Parameter	Value	Comments
onDurationTimer	psf1	
drx-InactivityTimer	psf1	
drx-RetransmissionTimer	psf1	
longDRX-CycleStartOffset	sf2560, 0	
shortDRX	disabled	
NOTE: For further information see clause 6.3.2 in TS 36.331.		

12.2 Demodulation of PSSCH

The purpose of the requirements in this subclause is to verify the PSSCH demodulation performance with a single active PSSCH link.

12.2.1 FDD

The minimum requirements are specified in Table 12.2.1-2 with the test parameters specified in Table 12.2.1-1. This test specifies an out-of-coverage scenario where Sidelink UE 1 is the synchronization reference only and Sidelink UE 2 transmits PSSCH and PSSCH.

Table 12.2.1-1: Test Parameters

Parameter		Unit	Test 1	
Communication resource pool configuration			As specified in Table A.7.2.1-1 (Configuration #1-FDD)	
N_{oc} at antenna port (NOTE 1)		dBm/15 kHz	-98	
Active cell(s)			None	
Sidelink UE 1	Sidelink Transmissions		SLSS + PSBCH	
	networkControlledSyncTx		ON	
	slssid		30	
	inCoverage (in MIB-SL)		FALSE	
	syncOffsetIndicator		Set same as syncOffsetIndicator1 in Configuration #1-FDD	
	Propagation channel		EPA5	
	Antenna configuration		1x2 Low	
	\widehat{E}_s at antenna port	dBm/15 kHz	-85	
Sidelink UE 2	Sidelink Transmissions		PSCCH + PSSCH	
	PSCCH RMC		5MHz: CC.3 FDD 10 MHz: CC.4 FDD	
	PSCCH subframe allocation		As defined by TS 36.213 with n_{PSCCH} chosen randomly (uniformly) in $[0, \lfloor M_{RB}^{PSCCH_RP} / 2 \rfloor L_{PSCCH} - 1]$ every sc-period	
	PSCCH RB allocation			
		\widehat{E}_s of PSCCH at antenna port	dBm/15 kHz	-85
		PSSCH RMC		As specified in Table 12.2.1-2
		PSSCH subframe allocation		As per time repetition pattern specified in PSCCH
		PSSCH RB allocation		First transmission: Chosen randomly (uniformly) among the allowed RBs as per TS36.213 HARQ retransmission: As per frequency hopping indicated in PSCCH and specified in TS36.213
		Time offset (NOTE 2)	μ s	+1
		Frequency offset (NOTE 3)	Hz	+200
	Propagation Channel		EVA70	
	Antenna configuration		1x2 Low	
NOTE 1: Applicable to both DL channel and ProSe Direct Communication Subframes on UL.				
NOTE 2: Time offset of Sidelink UE 2 receive signal timing with respect to Sidelink UE 1 receive signal timing at the tested UE.				
NOTE 3: Frequency offset of Sidelink UE 2 with respect to Sidelink UE 1 transmit frequency.				

Table 12.2.1-2: Minimum performance

Test num.	Sidelink UE	Band-width	PSSCH Reference channel	Reference value	
				Fraction of maximum throughput (%) (NOTE 1)	SNR (dB) of PSSCH
1	2	10 MHz	CD.1 FDD	70	-3.4
		5 MHz		70	-3.3
NOTE 1: The throughput is measured after 40 radio frames of lead time during which the test UE detects and synchronizes to Sidelink UE 1.					

12.3 Demodulation of PSCCH

The purpose of the requirements in this subclause is to verify the PSCCH demodulation performance with a single active PSSCH link.

12.3.1 FDD

The minimum requirements are specified in Table 12.3.1-2 with the test parameters specified in Table 12.3.1-1. This test specifies an out-of-coverage scenario where Sidelink UE 1 is the synchronization reference only and Sidelink UE 2 transmits PSCCH and PSSCH.

Table 12.3.1-1: Test Parameters

Parameter		Unit	Test 1
Communication resource pool configuration			As specified in Table A.7.2.1-1 (Configuration #1-FDD)
N_{oc} at antenna port (NOTE 1)		dBm/15 kHz	-98
Active cell(s)			None
Sidelink UE 1	Sidelink Transmissions		SLSS + PSBCH
	networkControlledSyncTx		ON
	slssid		30
	inCoverage (in MIB-SL)		FALSE
	syncOffsetIndicator		Set same as syncOffsetIndicator1 in Configuration #1-FDD
	Propagation channel		EPA5
	Antenna configuration		1x2 Low
\hat{E}_s at antenna port	dBm/15 kHz		-85
Sidelink UE 2	Sidelink Transmissions		PSCCH + PSSCH
	PSCCH RMC		As specified in Table 12.3.1-2
	PSCCH subframe allocation		As defined by TS 36.213 with n_{PSCCH} chosen randomly (uniformly) in $[0, \lfloor M_{RB}^{PSCCH-RP} / 2 \rfloor L_{PSCCH} - 1]$ every sc-period
	PSCCH RB allocation		
	PSSCH RMC		CD.1 FDD
	PSSCH subframe allocation		As per time repetition pattern specified in PSCCH
	PSSCH RB allocation		First transmission: Chosen randomly (uniformly) among the allowed RBs as per TS36.213 HARQ retransmission: As per frequency hopping indicated in PSCCH and specified in TS36.213
	Time offset (NOTE 2)	μ s	+1
	Frequency offset (NOTE 3)	Hz	+200
	Propagation Channel		EVA70
Antenna configuration		1x2 Low	
NOTE 1: Applicable to both DL channel and ProSe Direct Communication Subframes on UL.			
NOTE 2: Time offset of Sidelink UE 2 receive signal timing with respect to Sidelink UE 1 receive signal timing at the tested UE.			
NOTE 3: Frequency offset of Sidelink UE 2 with respect to Sidelink UE 1 transmit frequency.			

Table 12.3.1-2: Minimum performance

Test num.	Sidelink UE	Bandwidth	PSCCH Reference channel	Reference value	
				Probability of missed PSCCH (%) (NOTE 1)	SNR (dB) of PSCCH
1	2	10 MHz	CC.4 FDD	1	4.7
		5 MHz	CC.3 FDD	1	4.8
NOTE 1: The probability is measured after 40 radio frames of lead time during which the test UE detects and synchronizes to Sidelink UE 1.					

12.4 Demodulation of PSBCH

The purpose of the requirements in this subclause is to verify the PSBCH demodulation performance with a single active link.

12.4.1 FDD

The minimum requirements are specified in Table 12.4.1-2 with the test parameters specified in Table 12.4.1-1.

Table 12.4.1-1: Test Parameters

Parameter		Unit	Test 1
Communication resource pool configuration			As specified in Table A.7.2.1-1 (Configuration #1-FDD)
N_{oc} at antenna port		dBm/15kHz	-98
Active cell(s)			None
Sidelink UE 1	Sidelink Transmissions		SLSS + PSBCH (CP.1 FDD)
	networkControlledSyncTx		ON
	slssid		30
	inCoverage (in MIB-SL)		FALSE
	syncOffsetIndicator		Set same as syncOffsetIndicator1 in Configuration #1-FDD
	Propagation channel		EPA5
	Antenna configuration		1x2 Low

Table 12.4.1-2: Minimum performance

Test num.	Sidelink UE	Band-width	Reference channel	Reference value	
				Probability of missed PSBCH (%) (NOTE 1)	SNR (dB)
1	1	10 MHz	PSBCH (CP.1 FDD)	1	4.4
		5 MHz			
NOTE 1: The probability is measured after 40 radio frames of lead time during which the test UE detects and synchronizes to Sidelink UE 1.					

12.5 Power imbalance performance with two links

The purpose of this test is to check the demodulation performance when receiving PSSCH transmissions from two Sidelink UEs with power imbalance in one subframe.

12.5.1 FDD

The test parameters in Table 12.5.1-1 specifies an in-coverage scenario where Sidelink UE 1 and 2 are synchronized to Cell 1 and transmit PSSCH on adjacent RBs. The minimum requirements are specified in Table 12.5.1-2.

Table 12.5.1-1: Test Parameters

Parameter		Unit	Test 1	
Communication resource pool configuration			As specified in Table A.7.2.1-2 (Configuration #2-FDD)	
DRX configuration			As specified in Table 12.1.2-1	
N_{oc} at antenna port (NOTE 3)		dBm/15kHz	-98	
Active cell(s)			Cell 1 (Serving cell)	
Cell 1	Cyclic prefix		Normal	
	Cell ID		0	
	Downlink power allocation	ρ_A	dB	0
		ρ_B	dB	0 (NOTE 1)
		σ	dB	0
	OCNG Pattern (NOTE 2)			OP.1 FDD
	Propagation channel			AWGN
	Antenna configuration			1x2
RSRP		dBm/15kHz	-92	
Active Sidelink UE(s)			Sidelink UE 1, Sidelink UE 2	
Sidelink UE 1	Sidelink Transmissions		PSCCH + PSSCH	
	PSCCH RMC		5 MHz: CC.1 FDD 10 MHz: CC.2 FDD	
	PSCCH subframe allocation		$n_{PSCCH} = 0$ (as defined in TS 36.213)	
	PSCCH RB allocation			
	\hat{E}_s of PSCCH at antenna port		dBm/15kHz	-85
	PSSCH RMC		As specified in Table 12.5.1-2	
	PSSCH subframe allocation		As per time repetition pattern specified in PSCCH	
	PSSCH RB allocation		PRB pairs {4, 5}	
	Time offset (NOTE 4)		μ s	0
	Frequency offset (NOTE 5)		Hz	0
	Propagation Channel			AWGN
Antenna configuration			1x2	
Sidelink UE 2	Sidelink Transmissions		PSCCH + PSSCH	
	PSCCH RMC		5 MHz: CC.1 FDD 10 MHz: CC.2 FDD	
	PSCCH subframe allocation		$n_{PSCCH} = 2$ (as defined in TS 36.213)	
	PSCCH RB allocation			
	\hat{E}_s of PSCCH at antenna port		dBm/15kHz	-85
	PSSCH RMC		As specified in Table 12.5.1-2	
	PSSCH subframe allocation		As per time repetition pattern specified in PSCCH	
	PSSCH RB allocation		PRB pairs {6, 7}	
	Time offset (NOTE 4)		μ s	0
	Frequency offset (NOTE 5)		Hz	0
	Propagation Channel			AWGN
Antenna configuration			1x2	

NOTE 1: $P_B = 0$.

NOTE 2: OCNG is used to fully allocate the available resource blocks to virtual UEs.

NOTE 3: Applicable to both DL channel and ProSe Direct Communication Subframes on UL.

NOTE 4: Time offset of Sidelink UE receive signal with respect to Cell 1 downlink timing at the tested UE.

NOTE 5: Frequency offset of Sidelink UE with respect to Cell 1 uplink frequency.

Table 12.5.1-2: Minimum performance

Test num.	Bandwidth	Sidelink UE	PSSCH Reference channel	Reference value	
				Fraction of maximum throughput (%)	SNR (dB) of PSSCH
1	5 / 10 MHz	1	CD.5 FDD	(NOTE 1)	24.35
		2	CD.5 FDD	70	2.4

NOTE 1: There is no throughput requirement for Sidelink UE 1.

12.6 Multiple timing reference test

The purpose of this test is to check the PSSCH demodulation performance when receiving from two Sidelink UEs that follow different timing references and transmitting on different resources (non-overlapping in time).

12.6.1 FDD

The test parameters are specified in Table 12.6.1-1. Sidelink UE 2 and the receiver UE under test are associated with Cell 1. Sidelink UE 1 and Sidelink UE 3 are associated with another cell and use a different timing, and Sidelink UE 1 acts as a synchronization reference only. The minimum requirements are specified in Table 12.6.1-2.

Table 12.6.1-1: Test Parameters

Parameter		Unit	Test 1	
Communication resource pool configuration			As specified in Table A.7.2.1-3 (Configuration #3-FDD)	
DRX configuration			As specified in Table 12.1.2-1	
N_{oc} at antenna port (NOTE 3)		dBm/15kHz	-98	
Active cell(s)			Cell 1 (Serving cell)	
Cell 1	Cyclic prefix		Normal	
	Cell ID		0	
	Downlink power allocation	ρ_A	dB	0
		ρ_B	dB	0 (NOTE 1)
		σ	dB	0
	OCNG Pattern ^{NOTE 2}		OP.1 FDD	
	Propagation channel		AWGN	
	Antenna configuration		1x2	
RSRP	dBm/15kHz	-92		
Active Sidelink UE(s)			Sidelink UE 1, Sidelink UE 2, Sidelink UE 3	
Sidelink UE 1	Sidelink Transmissions		SLSS + PSBCH	
	networkControlledSyncTx		ON	
	slssid		30	
	inCoverage (in MIB-SL)		TRUE	
	syncOffsetIndicator		Set same as syncOffsetIndicator in Configuration #3-FDD	
	Time offset (NOTE 5)	ms	+12.51	
	Frequency offset (NOTE 6)	Hz	-100	
	Propagation channel		EPA5	
	Antenna configuration		1x2 Low	
\widehat{E}_s at antenna port	dBm/15kHz	-85		
Sidelink UE 2	Sidelink Transmissions		PSCCH + PSSCH	
	Resource pool		<i>commRxPool(0)</i>	
	PSCCH RMC		5MHz: CC.1 FDD 10 MHz: CC.2 FDD (NOTE 5)	
	PSCCH subframe allocation		As defined by TS 36.213 with n_{PSCCH} chosen randomly (uniformly) in	
	PSCCH RB allocation		$[0, \lfloor M_{RB}^{PSCCH - RP} / 2 \rfloor L_{PSCCH} - 1]$ every sc-period	
	\widehat{E}_s of PSCCH at antenna port	dBm/15kHz	-85	
	PSSCH RMC		As specified in Table 12.6.1-2	
	PSSCH subframe allocation		As per time repetition pattern specified in PSCCH	
	PSSCH RB allocation		First transmission: Chosen randomly (uniformly) among the allowed RBs as per TS36.213 HARQ retransmission: As per frequency hopping indicated in PSCCH and specified in TS36.213	
	Time offset (NOTE 4, 5)		PSCCH: +1 μ s PSSCH: +1 μ s – 288T _s	
	Frequency offset (NOTE 6)	Hz	+200	
	Propagation Channel		EVA70	
Antenna configuration		1x2 Low		
Sidelink UE 3	Sidelink Transmissions		PSCCH + PSSCH	
	Resource pool		<i>commRxPool(1)</i>	
	PSCCH RMC		5MHz: CC.5 FDD 10 MHz: CC.6 FDD	
	PSCCH subframe allocation		As defined by TS 36.213 with n_{PSCCH} chosen randomly (uniformly) in	
	PSCCH RB allocation		$[0, \lfloor M_{RB}^{PSCCH - RP} / 2 \rfloor L_{PSCCH} - 1]$ every sc-period	
	\widehat{E}_s of PSCCH at antenna port	dBm/15kHz	-85	
	PSSCH RMC		As specified in Table 12.6.1-2	

	PSSCH subframe allocation		As per time repetition pattern specified in PSCCH
	PSSCH RB allocation		First transmission: Chosen randomly (uniformly) among the allowed RBs as per TS36.213 HARQ retransmission: As per frequency hopping indicated in PSCCH and specified in TS36.213
	Time offset (NOTE 5)	ms	+12.509
	Frequency offset (NOTE 6)	Hz	+300
	Propagation Channel		EVA70
	Antenna configuration		1x2 Low
NOTE 1: $P_B = 0$.			
NOTE 2: OCNG is used to fully allocate the available resource blocks to virtual UEs.			
NOTE 3: Applicable to both DL channel and ProSe Direct Communication Subframes on UL.			
NOTE 4: Timing advance indication in PSSCH is set as 18 ($=288T_s$) in this test. PSSCH timing is advanced with respect to PSCCH timing by the quantity (i.e., PSSCH timing shall be $+1\mu s - 288T_s$ in this test).			
NOTE 5: Time offset of Sidelink UE receive signal with respect to Cell 1 downlink timing at the tested UE.			
NOTE 6: Frequency offset of Sidelink UE with respect to Cell 1 uplink frequency.			

Table 12.6.1-2: Minimum performance

Test num.	Bandwidth	Sidelink UE	PSSCH Reference channel	Reference value	
				Fraction of maximum throughput (%) (NOTE 1)	SNR (dB)
1	10 MHz	2	CD.4 FDD	70	3.0
		3	CD.2 FDD	70	2.8
	5 MHz	2	CD.3 FDD	70	2.9
		3	CD.2 FDD	70	2.8
NOTE 1: The throughput is measured after 40 radio frames of lead time during which the test UE detects and synchronizes to Sidelink UE 1.					

12.7 Maximum Sidelink processes test

The purpose of this test is to verify the maximum number of Sidelink processes and the maximum number of bits per TTI supported by the UE.

12.7.1 FDD

The test parameters are specified in Table 12.7.1-1. Multiple communication resource pools are interleaved. Each active Sidelink UE transmits in one of the resource pools with 3 retransmissions. The minimum requirements are specified in Table 12.7.1-2.

Table 12.7.1-1: Test Parameters

Parameter		Unit	Test 1	
Communication resource pool configuration			As specified in Table A.7.2.1-4 (Configuration #4-FDD)	
DRX configuration			As specified in Table 12.1.2-1	
Active cell(s)			Cell 1 (Serving cell)	
Cell 1	Cyclic prefix		Normal	
	Cell ID		0	
	Downlink power allocation	ρ_A	dB	0
		ρ_B	dB	0 (NOTE 1)
		σ	dB	0
	OCNG Pattern (NOTE 2)			OP.1 FDD
	Propagation channel			Static propagation condition No external noise sources are applied
	Antenna configuration			1x2
RSRP		dBm/15kHz	-85	
Active Sidelink UE(s)			Sidelink UE i , $0 \leq i \leq 15$	
Sidelink UE i , $0 \leq i \leq 15$	Sidelink Transmissions		PSCCH + PSSCH	
	Resource pool		$commRxPool(\lfloor \frac{i}{8} \rfloor)$	
	PSCCH RMC		5MHz: CC.1 FDD with $I_{TRP}=i\%8$ (NOTE 3) 10 MHz: CC.2 FDD with $I_{TRP}=i\%8$ (NOTE 3)	
	PSCCH subframe allocation		As defined by TS 36.213 with $n_{PSCCH} = i$	
	PSCCH RB allocation			
	PSSCH RMC		As specified in Table 12.7.1-2	
	PSSCH subframe allocation		As per time repetition pattern specified in PSCCH	
	PSSCH RB allocation		Fully allocated	
	Time offset (NOTE 4)		μs	0
	Frequency offset (NOTE 5)		Hz	0
	Propagation Channel			Static propagation condition No external noise sources are applied
	Antenna configuration			1x2 Low
NOTE 1: $P_B = 0$.				
NOTE 2: OCNG is used to fully allocate the available resource blocks to virtual UEs.				
NOTE 3: For $N_{TRP} = 8$ (FDD) and $trpt-Subset = 001$, $I_{TRP} = 0$ corresponds to a time repetition pattern of (1,0,0,0,0,0,0,0), $I_{TRP} = 1$ corresponds to a time repetition pattern of (0,1,0,0,0,0,0,0), etc.				
NOTE 4: Time offset of Sidelink UE receive signal with respect to Cell 1 downlink timing at the tested UE.				
NOTE 5: Frequency offset of Sidelink UE with respect to Cell 1 uplink frequency.				

Table 12.7.1-2: Minimum performance

Test num.	Bandwidth	PSCCH Reference channel	\hat{E}_s at antenna port (dBm/15kHz)	Reference value for Sidelink UE $i=0...15$
				Fraction of maximum throughput (%)
1	10 MHz	CD.7 FDD	-85	95
	5 MHz	CD.6 FDD	-85	95

12.8 Sustained downlink data rate with active Sidelink

The purpose of this test is to verify the downlink data rate is not impacted when Sidelink resource are also configured. The test parameters are in Table 12.8.1-1. Cell 1 is the serving cell and UE 1 and UE 2 are transmitters of Prose Direct Communication. The test UE is expected to receive all PDSCH transmissions, and prioritize the transmission of ACK/NACK over the reception of UE 2's PSSCH.

The test cases apply to UE categories and bandwidth combinations with maximum aggregated bandwidth as specified in Table 12.8.1-2. The minimum requirements are specified in Table 12.8.1-3. The TB success rate in the cellular link shall be sustained during at least 300 frames.

Table 12.8.1-1: Test parameters for sustained downlink data rate (FDD 64QAM) with active Sidelink

Parameter		Unit	Test 1, 2, 3A
Communication resource pool configuration			As specified in Table A.7.2.1-5 (Configuration #5-FDD)
Active cell(s)			Cell 1 (Serving cell)
Cell 1	Test parameters		As specified in clause 8.7.1: Table 8.7.1-1 and Test 1, 2, 3A in Table 8.7.1-2
Active Sidelink UE(s)			Sidelink UE 1, Sidelink UE 2
Sidelink UE 1	Sidelink Transmissions		PSCCH + PSSCH
	PSCCH RMC		10 MHz: CC.2 FDD with $I_{TRP}=0$ (NOTE 1)
	PSCCH subframe allocation		As defined by TS 36.213 with $n_{PSCCH} = 0$
	PSCCH RB allocation		
	PSSCH RMC		10 MHz: CD.7 FDD
	PSSCH subframe allocation		As per time repetition pattern specified in PSCCH
	PSSCH RB allocation		Fully allocated
	Time offset (NOTE 3)	μs	0
	Frequency offset (NOTE 4)	Hz	0
	Propagation Channel		Static propagation condition No external noise sources are applied
	Antenna configuration		1x2 Low
\widehat{E}_s at antenna port	dBm/15kHz	-85	
Sidelink UE 2	Sidelink Transmissions		PSCCH (NOTE 2)
	PSCCH RMC		10 MHz: CC.2 FDD with $I_{TRP}=1$ (NOTE 1)
	PSCCH subframe allocation		As defined by TS 36.213 with $n_{PSCCH} = 1$
	PSCCH RB allocation		
	Time offset (NOTE 3)	μs	0
	Frequency offset (NOTE 4)	Hz	0
	Propagation Channel		Static propagation condition No external noise sources are applied
	Antenna configuration		1x2 Low
	\widehat{E}_s at antenna port	dBm/15kHz	-85

NOTE 1: For $N_{TRP} = 8$ (FDD) and $trpt-Subset = 001$, $I_{TRP} = 0$ corresponds to a time repetition pattern of (1,0,0,0,0,0,0,0), $I_{TRP} = 1$ corresponds to a time repetition pattern of (0,1,0,0,0,0,0,0).

NOTE 2: Sidelink UE 2 transmits PSCCH but not PSSCH.

NOTE 3: Time offset of Sidelink UE receive signal with respect to Cell 1 downlink timing at the tested UE.

NOTE 4: Frequency offset of Sidelink UE with respect to Cell 1 uplink frequency.

Table 12.8.1-2: Test cases for sustained data rate

CA config	Maximum supported Bandwidth/ Bandwidth combination (MHz)	Cat. 1	Cat. 2	Cat. 3	Cat. 4	Cat. 6,7	Cat. 9,10	Cat 11, 12
Single carrier	10	1	2	3A	3A	3A	3A	3A

Table 12.8.1-3: Minimum requirements (FDD 64QAM) with active Sidelink

Test	Bandwidth (MHz)	Number of bits of a DL-SCH transport block received within a TTI	Measurement channel	Reference value
				PDSCH TB success rate (%)
1	10	10296	R.31-1 FDD (NOTE 2)	95
2	10	25456	R.31-2 FDD (NOTE 2)	95
3A	10	36696 (NOTE 1)	R.31-3A FDD (NOTE 2)	85
NOTE 1: 35160 bits for sub-frame 5.				
NOTE 2: PDSCH scheduling pattern is changed as per the following bitmap that repeats every 40ms. PDSCH scheduling subframe bitmap = {01110111 11110111 11110111 11110111 11111110}.				

Annex A (normative): Measurement channels

A.1 General

The throughput values defined in the measurement channels specified in Annex A, are calculated and are valid per datastream (codeword). For multi-stream (more than one codeword) transmissions, the throughput referenced in the minimum requirements is the sum of throughputs of all datastreams (codewords).

The UE category entry in the definition of the reference measurement channel in Annex A is only informative and reveals the UE categories, which can support the corresponding measurement channel. Whether the measurement channel is used for testing a certain UE category or not is specified in the individual minimum requirements.

A.2 UL reference measurement channels

A.2.1 General

The measurement channels in the following subclauses are defined to derive the requirements in clause 6 (Transmitter Characteristics) and clause 7 (Receiver Characteristics). The measurement channels represent example configurations of physical channels for different data rates.

A.2.1.1 Applicability and common parameters

The UL reference measurement channels comprise transmission of PUSCH and Demodulation Reference signals only. The following conditions apply:

- 1 HARQ transmission
- Cyclic Prefix normal
- PUSCH hopping off
- Link adaptation off
- Demodulation Reference signal as per TS 36.211 [4] subclause 5.5.2.1.2.

Where ACK/NACK is transmitted, it is assumed to be multiplexed on PUSCH as per TS 36.212 [5] subclause 5.2.2.6.

- ACK/NACK 1 bit
- ACK/NACK mapping adjacent to Demodulation Reference symbol
- ACK/NACK resources punctured into data
- Max number of resources for ACK/NACK: 4 SC-FDMA symbols per subframe
- No CQI transmitted, no RI transmitted

A.2.1.2 Determination of payload size

The algorithm for determining the payload size A is as follows; given a desired coding rate R and radio block allocation N_{RB}

1. Calculate the number of channel bits N_{ch} that can be transmitted during the first transmission of a given sub-frame.
2. Find A such that the resulting coding rate is as close to R as possible, that is,

$$\min |R - (A + 24 * (N_{CB} + 1)) / N_{ch}|, \text{ where } N_{CB} = \begin{cases} 0, & \text{if } C = 1 \\ C, & \text{if } C > 1 \end{cases}$$

subject to

- a) A is a valid TB size according to section 7.1.7 of TS 36.213 [6] assuming an allocation of N_{RB} resource blocks.
- b) C is the number of Code Blocks calculated according to section 5.1.2 of TS 36.212 [5].
- c) For RMC-s, which at the nominal target coding rate do not cover all the possible UE categories for the given modulation, reduce the target coding rate gradually (within the same modulation), until the maximal possible number of UE categories is covered.

3. If there is more than one A that minimises the equation above, then the larger value is chosen per default and the chosen code rate should not exceed 0.93.

A.2.1.3 Overview of UL reference measurement channels

In Table A.2.1.3-1 to A.2.1.3-1G are listed the UL reference measurement channels specified in annexes A.2.2 and A.2.3 of this release of TS 36.101. This table is informative and serves only to a better overview. The reference for the concrete reference measurement channels and corresponding implementation's parameters as to be used for requirements are annexes A.2.2 and A.2.3 as appropriate.

Table A.2.1.3-1: Overview of UL reference measurement channels (FDD, Full RB allocation, QPSK)

Duplex	Table	Name	BW	Mod	TCR	RB	RB Off set	UE Cat eg	Notes
FDD	Table A.2.2.1.1-1		1.4	QPSK	1/3	6		≥ 1	
FDD	Table A.2.2.1.1-1		3	QPSK	1/3	15		≥ 1	
FDD	Table A.2.2.1.1-1		5	QPSK	1/3	25		≥ 1	
FDD	Table A.2.2.1.1-1		10	QPSK	1/3	50		≥ 1	
FDD	Table A.2.2.1.1-1		15	QPSK	1/5	75		≥ 1	
FDD	Table A.2.2.1.1-1		20	QPSK	1/6	100		≥ 1	
FDD / HD-FDD	Table A.2.2.1.1-1a		1.4	QPSK	1/3	6		-	UE UL category 0
FDD / HD-FDD	Table A.2.2.1.1-1a		3	QPSK	1/5	15		-	UE UL category 0
FDD / HD-FDD	Table A.2.2.1.1-1a		5	QPSK	1/8	25		-	UE UL category 0
FDD / HD-FDD	Table A.2.2.1.1-1a		10	QPSK	1/10	36		-	UE UL category 0
FDD / HD-FDD	Table A.2.2.1.1-1a		15	QPSK	1/10	36		-	UE UL category 0
FDD / HD-FDD	Table A.2.2.1.1-1a		20	QPSK	1/10	36		-	UE UL category 0

Table A.2.1.3-1A: Overview of UL reference measurement channels (FDD, Full RB allocation, 16-QAM)

Duplex	Table	Name	BW	Mod	TCR	RB	RB Off set	UE Cat eg	Notes
FDD	Table A.2.2.1.2-1		1.4	16QAM	3/4	6		≥ 1	
FDD	Table A.2.2.1.2-1		3	16QAM	1/2	15		≥ 1	
FDD	Table A.2.2.1.2-1		5	16QAM	1/3	25		≥ 1	
FDD	Table A.2.2.1.2-1		10	16QAM	3/4	50		≥ 2	
FDD	Table A.2.2.1.2-1		15	16QAM	1/2	75		≥ 2	
FDD	Table A.2.2.1.2-1		20	16QAM	1/3	100		≥ 2	
FDD / HD-FDD	Table A.2.2.1.2-1a		1.4	16QAM	1/3	5		-	UE UL category 0
FDD / HD-FDD	Table A.2.2.1.2-1a		3	16QAM	1/3	5		-	UE UL category 0
FDD / HD-FDD	Table A.2.2.1.2-1a		5	16QAM	1/3	5		-	UE UL category 0
FDD / HD-FDD	Table A.2.2.1.2-1a		10	16QAM	1/3	5		-	UE UL category 0
FDD / HD-FDD	Table A.2.2.1.2-1a		15	16QAM	1/3	5		-	UE UL category 0
FDD / HD-FDD	Table A.2.2.1.2-1a		20	16QAM	1/3	5		-	UE UL category 0

Table A.2.1.3-1B: Overview of UL reference measurement channels (FDD, Partial RB allocation, QPSK)

Duplex	Table	Name	BW	Mod	TCR	RB	RB Off set	UE Cat eg	Notes
FDD	Table A.2.2.2.1-1		1.4 - 20	QPSK	1/3	1		≥ 1	
FDD	Table A.2.2.2.1-1		1.4 - 20	QPSK	1/3	2		≥ 1	
FDD	Table A.2.2.2.1-1		1.4 - 20	QPSK	1/3	3		≥ 1	
FDD	Table A.2.2.2.1-1		1.4 - 20	QPSK	1/3	4		≥ 1	
FDD	Table A.2.2.2.1-1		1.4 - 20	QPSK	1/3	5		≥ 1	
FDD	Table A.2.2.2.1-1		3 - 20	QPSK	1/3	6		≥ 1	
FDD	Table A.2.2.2.1-1		3 - 20	QPSK	1/3	8		≥ 1	
FDD	Table A.2.2.2.1-1		3 - 20	QPSK	1/3	9		≥ 1	
FDD	Table A.2.2.2.1-1		3 - 20	QPSK	1/3	10		≥ 1	
FDD	Table A.2.2.2.1-1		3 - 20	QPSK	1/3	12		≥ 1	
FDD	Table A.2.2.2.1-1		5 - 20	QPSK	1/3	15		≥ 1	
FDD	Table A.2.2.2.1-1		5 - 20	QPSK	1/3	16		≥ 1	
FDD	Table A.2.2.2.1-1		5 - 20	QPSK	1/3	18		≥ 1	
FDD	Table A.2.2.2.1-1		5 - 20	QPSK	1/3	20		≥ 1	
FDD	Table A.2.2.2.1-1		5 - 20	QPSK	1/3	24		≥ 1	
FDD	Table A.2.2.2.1-1		10 - 20	QPSK	1/3	25		≥ 1	
FDD	Table A.2.2.2.1-1		10 - 20	QPSK	1/3	27		≥ 1	
FDD	Table A.2.2.2.1-1		10 - 20	QPSK	1/3	30		≥ 1	
FDD	Table A.2.2.2.1-1		10 - 20	QPSK	1/3	32		≥ 1	
FDD	Table A.2.2.2.1-1		10 - 20	QPSK	1/3	36		≥ 1	
FDD	Table A.2.2.2.1-1		10 - 20	QPSK	1/3	40		≥ 1	
FDD	Table A.2.2.2.1-1		10 - 20	QPSK	1/3	45		≥ 1	
FDD	Table A.2.2.2.1-1		10 - 20	QPSK	1/3	48		≥ 1	
FDD	Table A.2.2.2.1-1		15 - 20	QPSK	1/3	50		≥ 1	
FDD	Table A.2.2.2.1-1		15 - 20	QPSK	1/3	54		≥ 1	
FDD	Table A.2.2.2.1-1		15 - 20	QPSK	1/4	60		≥ 1	
FDD	Table A.2.2.2.1-1		15 - 20	QPSK	1/4	64		≥ 1	
FDD	Table A.2.2.2.1-1		15 - 20	QPSK	1/4	72		≥ 1	
FDD	Table A.2.2.2.1-1		20	QPSK	1/5	75		≥ 1	
FDD	Table A.2.2.2.1-1		20	QPSK	1/5	80		≥ 1	
FDD	Table A.2.2.2.1-1		20	QPSK	1/5	81		≥ 1	
FDD	Table A.2.2.2.1-1		20	QPSK	1/6	90		≥ 1	
FDD	Table A.2.2.2.1-1		20	QPSK	1/6	96		≥ 1	
FDD / HD-FDD	Table A.2.2.2.1-1a		1.4 - 20	QPSK	1/3	1		-	UE UL category 0
FDD / HD-FDD	Table A.2.2.2.1-1a		1.4 - 20	QPSK	1/3	2		-	UE UL category 0
FDD / HD-FDD	Table A.2.2.2.1-1a		1.4 - 20	QPSK	1/3	3		-	UE UL category 0
FDD / HD-FDD	Table A.2.2.2.1-1a		1.4 - 20	QPSK	1/3	4		-	UE UL category 0
FDD / HD-FDD	Table A.2.2.2.1-1a		1.4 - 20	QPSK	1/3	5		-	UE UL category 0
FDD / HD-FDD	Table A.2.2.2.1-1a		3-20	QPSK	1/3	6		-	UE UL category 0
FDD / HD-FDD	Table A.2.2.2.1-1a		3-20	QPSK	1/3	8		-	UE UL category 0
FDD / HD-FDD	Table A.2.2.2.1-1a		3-20	QPSK	1/3	9		-	UE UL category 0
FDD / HD-FDD	Table A.2.2.2.1-1a		3-20	QPSK	1/3	10		-	UE UL category 0
FDD / HD-FDD	Table A.2.2.2.1-1a		3-20	QPSK	1/4	12		-	UE UL category 0
FDD / HD-FDD	Table A.2.2.2.1-1a		5-20	QPSK	1/5	15		-	UE UL category 0

FDD / HD-FDD	Table A.2.2.2.1-1a		5-20	QPSK	1/5	16		-	UE UL category 0
FDD / HD-FDD	Table A.2.2.2.1-1a		5-20	QPSK	1/6	18		-	UE UL category 0
FDD / HD-FDD	Table A.2.2.2.1-1a		5-20	QPSK	1/6	20		-	UE UL category 0
FDD / HD-FDD	Table A.2.2.2.1-1a		5-20	QPSK	1/8	24		-	UE UL category 0
FDD / HD-FDD	Table A.2.2.2.1-1a		10-20	QPSK	1/8	25		-	UE UL category 0
FDD / HD-FDD	Table A.2.2.2.1-1a		10-20	QPSK	1/8	27		-	UE UL category 0
FDD / HD-FDD	Table A.2.2.2.1-1a		10-20	QPSK	1/10	30		-	UE UL category 0

Table A.2.1.3-1C: Overview of UL reference measurement channels (FDD, Partial RB allocation, 16-QAM)

Duplex	Table	Name	BW	Mod	TCR	RB	RB Off set	UE Cat eg	Notes
FDD	Table A.2.2.2.2-1		1.4 - 20	16QAM	3/4	1		≥ 1	
FDD	Table A.2.2.2.2-1		1.4 - 20	16QAM	3/4	2		≥ 1	
FDD	Table A.2.2.2.2-1		1.4 - 20	16QAM	3/4	3		≥ 1	
FDD	Table A.2.2.2.2-1		1.4 - 20	16QAM	3/4	4		≥ 1	
FDD	Table A.2.2.2.2-1		1.4 - 20	16QAM	3/4	5		≥ 1	
FDD	Table A.2.2.2.2-1		3 - 20	16QAM	3/4	6		≥ 1	
FDD	Table A.2.2.2.2-1		3 - 20	16QAM	3/4	8		≥ 1	
FDD	Table A.2.2.2.2-1		3 - 20	16QAM	3/4	9		≥ 1	
FDD	Table A.2.2.2.2-1		3 - 20	16QAM	3/4	10		≥ 1	
FDD	Table A.2.2.2.2-1		3 - 20	16QAM	3/4	12		≥ 1	
FDD	Table A.2.2.2.2-1		5 - 20	16QAM	1/2	15		≥ 1	
FDD	Table A.2.2.2.2-1		5 - 20	16QAM	1/2	16		≥ 1	
FDD	Table A.2.2.2.2-1		5 - 20	16QAM	1/2	18		≥ 1	
FDD	Table A.2.2.2.2-1		5 - 20	16QAM	1/3	20		≥ 1	
FDD	Table A.2.2.2.2-1		5 - 20	16QAM	1/3	24		≥ 1	
FDD	Table A.2.2.2.2-1		10 - 20	16QAM	1/3	25		≥ 1	
FDD	Table A.2.2.2.2-1		10 - 20	16QAM	1/3	27		≥ 1	
FDD	Table A.2.2.2.2-1		10 - 20	16QAM	3/4	30		≥ 2	
FDD	Table A.2.2.2.2-1		10 - 20	16QAM	3/4	32		≥ 2	
FDD	Table A.2.2.2.2-1		10 - 20	16QAM	3/4	36		≥ 2	
FDD	Table A.2.2.2.2-1		10 - 20	16QAM	3/4	40		≥ 2	
FDD	Table A.2.2.2.2-1		10 - 20	16QAM	3/4	45		≥ 2	
FDD	Table A.2.2.2.2-1		10 - 20	16QAM	3/4	48		≥ 2	
FDD	Table A.2.2.2.2-1		15 - 20	16QAM	3/4	50		≥ 2	
FDD	Table A.2.2.2.2-1		15 - 20	16QAM	3/4	54		≥ 2	
FDD	Table A.2.2.2.2-1		15 - 20	16QAM	2/3	60		≥ 2	
FDD	Table A.2.2.2.2-1		15 - 20	16QAM	2/3	64		≥ 2	
FDD	Table A.2.2.2.2-1		15 - 20	16QAM	1/2	72		≥ 2	
FDD	Table A.2.2.2.2-1		20	16QAM	1/2	75		≥ 2	
FDD	Table A.2.2.2.2-1		20	16QAM	1/2	80		≥ 2	
FDD	Table A.2.2.2.2-1		20	16QAM	1/2	81		≥ 2	
FDD	Table A.2.2.2.2-1		20	16QAM	2/5	90		≥ 2	
FDD	Table A.2.2.2.2-1		20	16QAM	2/5	96		≥ 2	
FDD / HD-FDD	Table A.2.2.2.2-1a		1.4 - 20	16QAM	3/4	1		-	UE UL category 0
FDD / HD-FDD	Table A.2.2.2.2-1a		1.4 - 20	16QAM	3/4	2		-	UE UL category 0
FDD / HD-FDD	Table A.2.2.2.2-1a		1.4 - 20	16QAM	2/5	4		-	UE UL category 0

Table A.2.1.3-1D: Overview of UL reference measurement channels (TDD, Full RB allocation, QPSK)

Duplex	Table	Name	BW	Mod	TCR	RB	RB Off set	UE Cat eg	Notes
TDD	Table A.2.3.1.1-1		1.4	QPSK	1/3	6		≥ 1	
TDD	Table A.2.3.1.1-1		3	QPSK	1/3	15		≥ 1	
TDD	Table A.2.3.1.1-1		5	QPSK	1/3	25		≥ 1	
TDD	Table A.2.3.1.1-1		10	QPSK	1/3	50		≥ 1	
TDD	Table A.2.3.1.1-1		15	QPSK	1/5	75		≥ 1	
TDD	Table A.2.3.1.1-1		20	QPSK	1/6	100		≥ 1	
TDD	Table A.2.3.1.1-1a		1.4	QPSK	1/3	6		-	UE UL category 0
TDD	Table A.2.3.1.1-1a		3	QPSK	1/5	15		-	UE UL category 0
TDD	Table A.2.3.1.1-1a		5	QPSK	1/8	25		-	UE UL category 0
TDD	Table A.2.3.1.1-1a		10	QPSK	1/10	36		-	UE UL category 0
-	Table A.2.3.1.1-1a		15	QPSK	1/10	36		-	UE UL category 0
TDD	Table A.2.3.1.1-1a		20	QPSK	1/10	36		-	UE UL category 0

Table A.2.1.3-1E: Overview of UL reference measurement channels (TDD, Full RB allocation, 16-QAM)

Duplex	Table	Name	BW	Mod	TCR	RB	RB Off set	UE Cat eg	Notes
TDD	Table A.2.3.1.2-1		1.4	16QAM	3/4	6		≥ 1	
TDD	Table A.2.3.1.2-1		3	16QAM	1/2	15		≥ 1	
TDD	Table A.2.3.1.2-1		5	16QAM	1/3	25		≥ 1	
TDD	Table A.2.3.1.2-1		10	16QAM	3/4	50		≥ 2	
TDD	Table A.2.3.1.2-1		15	16QAM	1/2	75		≥ 2	
TDD	Table A.2.3.1.2-1		20	16QAM	1/3	100		≥ 2	
TDD	Table A.2.3.1.2-1a		1.4	16QAM	1/3	5		-	UE UL category 0
TDD	Table A.2.3.1.2-1a		3	16QAM	1/3	5		-	UE UL category 0
TDD	Table A.2.3.1.2-1a		5	16QAM	1/3	5		-	UE UL category 0
TDD	Table A.2.3.1.2-1a		10	16QAM	1/3	5		-	UE UL category 0
TDD	Table A.2.3.1.2-1a		15	16QAM	1/3	5		-	UE UL category 0
TDD	Table A.2.3.1.2-1a		20	16QAM	1/3	5		-	UE UL category 0

Table A.2.1.3-1F: Overview of UL reference measurement channels (TDD, Partial RB allocation, QPSK)

Duplex	Table	Name	BW	Mod	TCR	RB	RB Off set	UE Cat eg	Notes
TDD	Table A.2.3.2.1-1		1.4 - 20	QPSK	1/3	1		≥ 1	
TDD	Table A.2.3.2.1-1		1.4 - 20	QPSK	1/3	2		≥ 1	
TDD	Table A.2.3.2.1-1		1.4 - 20	QPSK	1/3	3		≥ 1	
TDD	Table A.2.3.2.1-1		1.4 - 20	QPSK	1/3	4		≥ 1	
TDD	Table A.2.3.2.1-1		1.4 - 20	QPSK	1/3	5		≥ 1	
TDD	Table A.2.3.2.1-1		3 - 20	QPSK	1/3	6		≥ 1	
TDD	Table A.2.3.2.1-1		3 - 20	QPSK	1/3	8		≥ 1	
TDD	Table A.2.3.2.1-1		3 - 20	QPSK	1/3	9		≥ 1	
TDD	Table A.2.3.2.1-1		3 - 20	QPSK	1/3	10		≥ 1	
TDD	Table A.2.3.2.1-1		3 - 20	QPSK	1/3	12		≥ 1	
TDD	Table A.2.3.2.1-1		5 - 20	QPSK	1/3	15		≥ 1	
TDD	Table A.2.3.2.1-1		5 - 20	QPSK	1/3	16		≥ 1	
TDD	Table A.2.3.2.1-1		5 - 20	QPSK	1/3	18		≥ 1	
TDD	Table A.2.3.2.1-1		5 - 20	QPSK	1/3	20		≥ 1	
TDD	Table A.2.3.2.1-1		5 - 20	QPSK	1/3	24		≥ 1	
TDD	Table A.2.3.2.1-1		10 - 20	QPSK	1/3	25		≥ 1	
TDD	Table A.2.3.2.1-1		10 - 20	QPSK	1/3	27		≥ 1	
TDD	Table A.2.3.2.1-1		10 - 20	QPSK	1/3	30		≥ 1	
TDD	Table A.2.3.2.1-1		10 - 20	QPSK	1/3	32		≥ 1	
TDD	Table A.2.3.2.1-1		10 - 20	QPSK	1/3	36		≥ 1	
TDD	Table A.2.3.2.1-1		10 - 20	QPSK	1/3	40		≥ 1	
TDD	Table A.2.3.2.1-1		10 - 20	QPSK	1/3	45		≥ 1	
TDD	Table A.2.3.2.1-1		10 - 20	QPSK	1/3	48		≥ 1	
TDD	Table A.2.3.2.1-1		15 - 20	QPSK	1/3	50		≥ 1	
TDD	Table A.2.3.2.1-1		15 - 20	QPSK	1/3	54		≥ 1	
TDD	Table A.2.3.2.1-1		15 - 20	QPSK	1/4	60		≥ 1	
TDD	Table A.2.3.2.1-1		15 - 20	QPSK	1/4	64		≥ 1	
TDD	Table A.2.3.2.1-1		15 - 20	QPSK	1/4	72		≥ 1	
TDD	Table A.2.3.2.1-1		20	QPSK	1/5	75		≥ 1	
TDD	Table A.2.3.2.1-1		20	QPSK	1/5	80		≥ 1	
TDD	Table A.2.3.2.1-1		20	QPSK	1/5	81		≥ 1	
TDD	Table A.2.3.2.1-1		20	QPSK	1/6	90		≥ 1	
TDD	Table A.2.3.2.1-1		20	QPSK	1/6	96		≥ 1	
TDD	Table A.2.3.2.1-1a		1.4 - 20	QPSK	1/3	1		-	UE UL category 0
TDD	Table A.2.3.2.1-1a		1.4 - 20	QPSK	1/3	2		-	UE UL category 0
TDD	Table A.2.3.2.1-1a		1.4 - 20	QPSK	1/3	3		-	UE UL category 0
TDD	Table A.2.3.2.1-1a		1.4 - 20	QPSK	1/3	4		-	UE UL category 0
TDD	Table A.2.3.2.1-1a		1.4 - 20	QPSK	1/3	5		-	UE UL category 0
TDD	Table A.2.3.2.1-1a		3-20	QPSK	1/3	6		-	UE UL category 0
TDD	Table A.2.3.2.1-1a		3-20	QPSK	1/3	8		-	UE UL category 0
TDD	Table A.2.3.2.1-1a		3-20	QPSK	1/3	9		-	UE UL category 0
TDD	Table A.2.3.2.1-1a		3-20	QPSK	1/3	10		-	UE UL category 0
TDD	Table A.2.3.2.1-1a		3-20	QPSK	1/4	12		-	UE UL category 0
TDD	Table A.2.3.2.1-1a		5-20	QPSK	1/5	15		-	UE UL category 0

TDD	Table A.2.3.2.1-1a		5-20	QPSK	1/5	16		-	UE UL category 0
TDD	Table A.2.3.2.1-1a		5-20	QPSK	1/6	18		-	UE UL category 0
TDD	Table A.2.3.2.1-1a		5-20	QPSK	1/6	20		-	UE UL category 0
TDD	Table A.2.3.2.1-1a		5-20	QPSK	1/8	24		-	UE UL category 0
TDD	Table A.2.3.2.1-1a		10-20	QPSK	1/8	25		-	UE UL category 0
TDD	Table A.2.3.2.1-1a		10-20	QPSK	1/8	27		-	UE UL category 0
TDD	Table A.2.3.2.1-1a		10-20	QPSK	1/10	30		-	UE UL category 0

Table A.2.1.3-1G: Overview of UL reference measurement channels (TDD, Partial RB allocation, 16-QAM)

Duplex	Table	Name	BW	Mod	TCR	RB	RB Off set	UE Cat eg	Notes
TDD	Table A.2.3.2.2-1		1.4 - 20	16QAM	3/4	1		≥ 1	
TDD	Table A.2.3.2.2-1		1.4 - 20	16QAM	3/4	2		≥ 1	
TDD	Table A.2.3.2.2-1		1.4 - 20	16QAM	3/4	3		≥ 1	
TDD	Table A.2.3.2.2-1		1.4 - 20	16QAM	3/4	4		≥ 1	
TDD	Table A.2.3.2.2-1		1.4 - 20	16QAM	3/4	5		≥ 1	
TDD	Table A.2.3.2.2-1		3 - 20	16QAM	3/4	6		≥ 1	
TDD	Table A.2.3.2.2-1		3 - 20	16QAM	3/4	8		≥ 1	
TDD	Table A.2.3.2.2-1		3 - 20	16QAM	3/4	9		≥ 1	
TDD	Table A.2.3.2.2-1		3 - 20	16QAM	3/4	10		≥ 1	
TDD	Table A.2.3.2.2-1		3 - 20	16QAM	3/4	12		≥ 1	
TDD	Table A.2.3.2.2-1		5 - 20	16QAM	1/2	15		≥ 1	
TDD	Table A.2.3.2.2-1		5 - 20	16QAM	1/2	16		≥ 1	
TDD	Table A.2.3.2.2-1		5 - 20	16QAM	1/2	18		≥ 1	
TDD	Table A.2.3.2.2-1		5 - 20	16QAM	1/3	20		≥ 1	
TDD	Table A.2.3.2.2-1		5 - 20	16QAM	1/3	24		≥ 1	
TDD	Table A.2.3.2.2-1		10 - 20	16QAM	1/3	25		≥ 1	
TDD	Table A.2.3.2.2-1		10 - 20	16QAM	1/3	27		≥ 1	
TDD	Table A.2.3.2.2-1		10 - 20	16QAM	3/4	30		≥ 2	
TDD	Table A.2.3.2.2-1		10 - 20	16QAM	3/4	32		≥ 2	
TDD	Table A.2.3.2.2-1		10 - 20	16QAM	3/4	36		≥ 2	
TDD	Table A.2.3.2.2-1		10 - 20	16QAM	3/4	40		≥ 2	
TDD	Table A.2.3.2.2-1		10 - 20	16QAM	3/4	45		≥ 2	
TDD	Table A.2.3.2.2-1		10 - 20	16QAM	3/4	48		≥ 2	
TDD	Table A.2.3.2.2-1		15 - 20	16QAM	3/4	50		≥ 2	
TDD	Table A.2.3.2.2-1		15 - 20	16QAM	3/4	54		≥ 2	
TDD	Table A.2.3.2.2-1		15 - 20	16QAM	2/3	60		≥ 2	
TDD	Table A.2.3.2.2-1		15 - 20	16QAM	2/3	64		≥ 2	
TDD	Table A.2.3.2.2-1		15 - 20	16QAM	1/2	72		≥ 2	
TDD	Table A.2.3.2.2-1		20	16QAM	1/2	75		≥ 2	
TDD	Table A.2.3.2.2-1		20	16QAM	1/2	80		≥ 2	
TDD	Table A.2.3.2.2-1		20	16QAM	1/2	81		≥ 2	
TDD	Table A.2.3.2.2-1		20	16QAM	2/5	90		≥ 2	
TDD	Table A.2.3.2.2-1		20	16QAM	2/5	96		≥ 2	
TDD	Table A.2.3.2.2-1a		1.4 - 20	16QAM	3/4	1		-	UE UL category 0
TDD	Table A.2.3.2.2-1a		1.4 - 20	16QAM	3/4	2		-	UE UL category 0
TDD	Table A.2.3.2.2-1a		1.4 - 20	16QAM	2/5	4		-	UE UL category 0

A.2.2 Reference measurement channels for FDD

A.2.2.1 Full RB allocation

A.2.2.1.1 QPSK

Table A.2.2.1.1-1 Reference Channels for QPSK with full RB allocation

Parameter	Unit	Value					
		1.4	3	5	10	15	20
Channel bandwidth	MHz	1.4	3	5	10	15	20
Allocated resource blocks		6	15	25	50	75	100
DFT-OFDM Symbols per Sub-Frame		12	12	12	12	12	12
Modulation		QPSK	QPSK	QPSK	QPSK	QPSK	QPSK
Target Coding rate		1/3	1/3	1/3	1/3	1/5	1/6
Payload size	Bits	600	1544	2216	5160	4392	4584
Transport block CRC	Bits	24	24	24	24	24	24
Number of code blocks per Sub-Frame (Note 1)		1	1	1	1	1	1
Total number of bits per Sub-Frame	Bits	1728	4320	7200	14400	21600	28800
Total symbols per Sub-Frame		864	2160	3600	7200	10800	14400
UE Category		≥ 1	≥ 1	≥ 1	≥ 1	≥ 1	≥ 1

Note 1: If more than one Code Block is present, an additional CRC sequence of L = 24 Bits is attached to each Code Block (otherwise L = 0 Bit)

Table A.2.2.1.1-1a Reference Channels for QPSK with full/maximum RB allocation for UE UL category 0

Parameter	Unit	Value					
		1.4	3	5	10	15	20
Channel bandwidth	MHz	1.4	3	5	10	15	20
Allocated resource blocks		6	15	25	36	36	36
DFT-OFDM Symbols per Sub-Frame		12	12	12	12	12	12
Modulation		QPSK	QPSK	QPSK	QPSK	QPSK	QPSK
Target Coding rate		1/3	1/5	1/8	1/10	1/10	1/10
Payload size	Bits	600	872	904	1000	1000	1000
Transport block CRC	Bits	24	24	24	24	24	24
Number of code blocks per Sub-Frame (NOTE 1)		1	1	1	1	1	1
Total number of bits per Sub-Frame	Bits	1728	4320	7200	10368	10368	10368
Total symbols per Sub-Frame		864	2160	3600	5184	5184	5184
UE UL Category		0	0	0	0	0	0

NOTE 1: If more than one Code Block is present, an additional CRC sequence of L = 24 Bits is attached to each Code Block (otherwise L = 0 Bit)

NOTE 2: For HD-FDD UE, the uplink subframes are scheduled at the 4th, 5th, 6th, 12th, 13th, 14th, 20th, 21st, 22nd, 28th, 29th, 30th, 36th, 37th, and 38th subframes every 40ms. Information bit payload is available if uplink subframe is scheduled.

A.2.2.1.2 16-QAM

Table A.2.2.1.2-1 Reference Channels for 16-QAM with full RB allocation

Parameter	Unit	Value					
		1.4	3	5	10	15	20
Channel bandwidth	MHz	1.4	3	5	10	15	20
Allocated resource blocks		6	15	25	50	75	100
DFT-OFDM Symbols per Sub-Frame		12	12	12	12	12	12
Modulation		16QAM	16QAM	16QAM	16QAM	16QAM	16QAM
Target Coding rate		3/4	1/2	1/3	3/4	1/2	1/3
Payload size	Bits	2600	4264	4968	21384	21384	19848
Transport block CRC	Bits	24	24	24	24	24	24
Number of code blocks per Sub-Frame (Note 1)		1	1	1	4	4	4
Total number of bits per Sub-Frame	Bits	3456	8640	14400	28800	43200	57600
Total symbols per Sub-Frame		864	2160	3600	7200	10800	14400
UE Category		≥ 1	≥ 1	≥ 1	≥ 2	≥ 2	≥ 2
Note 1: If more than one Code Block is present, an additional CRC sequence of L = 24 Bits is attached to each Code Block (otherwise L = 0 Bit)							

Table A.2.2.1.2-1a Reference Channels for 16-QAM with maximum RB allocation for UE UL category 0

Parameter	Unit	Value					
		1.4	3	5	10	15	20
Channel bandwidth	MHz	1.4	3	5	10	15	20
Allocated resource blocks		5	5	5	5	5	5
DFT-OFDM Symbols per Sub-Frame		12	12	12	12	12	12
Modulation		16QAM	16QAM	16QAM	16QAM	16QAM	16QAM
Target Coding rate		1/3	1/3	1/3	1/3	1/3	1/3
Payload size	Bits	872	872	872	872	872	872
Transport block CRC	Bits	24	24	24	24	24	24
Number of code blocks per Sub-Frame		1	1	1	1	1	1
Total number of bits per Sub-Frame	Bits	2880	2880	2880	2880	2880	2880
Total symbols per Sub-Frame		720	720	720	720	720	720
UE UL Category		0	0	0	0	0	0
NOTE 1: If more than one Code Block is present, an additional CRC sequence of L = 24 Bits is attached to each Code Block (otherwise L = 0 Bit)							
NOTE 2: For HD-FDD UE, the uplink subframes are scheduled at the 4th, 5th, 6th, 12th, 13th, 14th, 20th, 21st, 22nd, 28th, 29th, 30th, 36th, 37th, and 38th subframes every 40ms. Information bit payload is available if uplink subframe is scheduled.							

A.2.2.1.3 64-QAM

[FFS]

A.2.2.2 Partial RB allocation

For each channel bandwidth, various partial RB allocations are specified. The number of allocated RBs is chosen according to values specified in the Tx and Rx requirements. The single allocated RB case is included.

The allocated RBs are contiguous and start from one end of the channel bandwidth. A single allocated RB is at one end of the channel bandwidth.

A.2.2.2.1 QPSK

Table A.2.2.2.1-1 Reference Channels for QPSK with partial RB allocation

Parameter	Ch BW	Allocated RBs	DFT-OFDM Symbols per Sub-Frame	Mod'n	Target Coding rate	Payload size	Transport block CRC	Number of code blocks per Sub-Frame (Note 1)	Total number of bits per Sub-Frame	Total symbols per Sub-Frame	UE Category
Unit	MHz					Bits	Bits		Bits		
	1.4 - 20	1	12	QPSK	1/3	72	24	1	288	144	≥ 1
	1.4 - 20	2	12	QPSK	1/3	176	24	1	576	288	≥ 1
	1.4 - 20	3	12	QPSK	1/3	256	24	1	864	432	≥ 1
	1.4 - 20	4	12	QPSK	1/3	392	24	1	1152	576	≥ 1
	1.4 - 20	5	12	QPSK	1/3	424	24	1	1440	720	≥ 1
	3-20	6	12	QPSK	1/3	600	24	1	1728	864	≥ 1
	3-20	8	12	QPSK	1/3	808	24	1	2304	1152	≥ 1
	3-20	9	12	QPSK	1/3	776	24	1	2592	1296	≥ 1
	3-20	10	12	QPSK	1/3	872	24	1	2880	1440	≥ 1
	3-20	12	12	QPSK	1/3	1224	24	1	3456	1728	≥ 1
	5-20	15	12	QPSK	1/3	1320	24	1	4320	2160	≥ 1
	5-20	16	12	QPSK	1/3	1384	24	1	4608	2304	≥ 1
	5-20	18	12	QPSK	1/3	1864	24	1	5184	2592	≥ 1
	5-20	20	12	QPSK	1/3	1736	24	1	5760	2880	≥ 1
	5-20	24	12	QPSK	1/3	2472	24	1	6912	3456	≥ 1
	10-20	25	12	QPSK	1/3	2216	24	1	7200	3600	≥ 1
	10-20	27	12	QPSK	1/3	2792	24	1	7776	3888	≥ 1
	10-20	30	12	QPSK	1/3	2664	24	1	8640	4320	≥ 1
	10-20	32	12	QPSK	1/3	2792	24	1	9216	4608	≥ 1
	10-20	36	12	QPSK	1/3	3752	24	1	10368	5184	≥ 1
	10-20	40	12	QPSK	1/3	4136	24	1	11520	5760	≥ 1
	10-20	45	12	QPSK	1/3	4008	24	1	12960	6480	≥ 1
	10-20	48	12	QPSK	1/3	4264	24	1	13824	6912	≥ 1
	15 - 20	50	12	QPSK	1/3	5160	24	1	14400	7200	≥ 1
	15 - 20	54	12	QPSK	1/3	4776	24	1	15552	7776	≥ 1
	15 - 20	60	12	QPSK	1/4	4264	24	1	17280	8640	≥ 1
	15 - 20	64	12	QPSK	1/4	4584	24	1	18432	9216	≥ 1
	15 - 20	72	12	QPSK	1/4	5160	24	1	20736	10368	≥ 1
	20	75	12	QPSK	1/5	4392	24	1	21600	10800	≥ 1
	20	80	12	QPSK	1/5	4776	24	1	23040	11520	≥ 1
	20	81	12	QPSK	1/5	4776	24	1	23328	11664	≥ 1
	20	90	12	QPSK	1/6	4008	24	1	25920	12960	≥ 1
	20	96	12	QPSK	1/6	4264	24	1	27648	13824	≥ 1

Note 1: If more than one Code Block is present, an additional CRC sequence of L = 24 Bits is attached to each Code Block (otherwise L = 0 Bit)

Table A.2.2.2.1-1a Reference Channels for QPSK with partial RB allocation for UE UL category 0

Parameter	Ch BW	Allocated RBs	DFT-OFDM Symbols per Sub-Frame	Mod'n	Target Coding rate	Payload size	Transport block CRC	Number of code blocks per Sub-Frame (Note 1)	Total number of bits per Sub-Frame	Total symbols per Sub-Frame	UE UL Category
Unit	MHz					Bits	Bits		Bits		
	1.4 - 20	1	12	QPSK	1/3	72	24	1	288	144	0
	1.4 - 20	2	12	QPSK	1/3	176	24	1	576	288	0
	1.4 - 20	3	12	QPSK	1/3	256	24	1	864	432	0
	1.4 - 20	4	12	QPSK	1/3	392	24	1	1152	576	0
	1.4 - 20	5	12	QPSK	1/3	424	24	1	1440	720	0
	3-20	6	12	QPSK	1/3	600	24	1	1728	864	0
	3-20	8	12	QPSK	1/3	808	24	1	2304	1152	0
	3-20	9	12	QPSK	1/3	776	24	1	2592	1296	0
	3-20	10	12	QPSK	1/3	872	24	1	2880	1440	0
	3-20	12	12	QPSK	1/4	840	24	1	3456	1728	0
	5-20	15	12	QPSK	1/5	872	24	1	4320	2160	0
	5-20	16	12	QPSK	1/5	904	24	1	4608	2304	0
	5-20	18	12	QPSK	1/6	776	24	1	5184	2592	0
	5-20	20	12	QPSK	1/6	872	24	1	5760	2880	0
	5-20	24	12	QPSK	1/8	872	24	1	6912	3456	0
	10-20	25	12	QPSK	1/8	904	24	1	7200	3600	0
	10-20	27	12	QPSK	1/8	968	24	1	7776	3888	0
	10-20	30	12	QPSK	1/10	808	24	1	8640	4320	0
Note 1:	If more than one Code Block is present, an additional CRC sequence of L = 24 Bits is attached to each Code Block (otherwise L = 0 Bit)										
Note 2:	For HD-FDD UE, the uplink subframes are scheduled at the 4th, 5th, 6th, 12th, 13th, 14th, 20th, 21st, 22nd, 28th, 29th, 30th, 36th, 37th, and 38th subframes every 40ms. Information bit payload is available if uplink subframe is scheduled.										

A.2.2.2.2 16-QAM

Table A.2.2.2-1 Reference Channels for 16-QAM with partial RB allocation

Parameter	Ch BW	Allocated RBs	DFT-OFDM Symbols per Sub-Frame	Mod'n	Target Coding rate	Payload size	Transport block CRC	Number of code blocks per Sub-Frame (Note 1)	Total number of bits per Sub-Frame	Total symbols per Sub-Frame	UE Category
Unit	MHz					Bits	Bits		Bits		
	1.4 - 20	1	12	16QAM	3/4	408	24	1	576	144	≥ 1
	1.4 - 20	2	12	16QAM	3/4	840	24	1	1152	288	≥ 1
	1.4 - 20	3	12	16QAM	3/4	1288	24	1	1728	432	≥ 1
	1.4 - 20	4	12	16QAM	3/4	1736	24	1	2304	576	≥ 1
	1.4 - 20	5	12	16QAM	3/4	2152	24	1	2880	720	≥ 1
	3-20	6	12	16QAM	3/4	2600	24	1	3456	864	≥ 1
	3-20	8	12	16QAM	3/4	3496	24	1	4608	1152	≥ 1
	3-20	9	12	16QAM	3/4	3880	24	1	5184	1296	≥ 1
	3-20	10	12	16QAM	3/4	4264	24	1	5760	1440	≥ 1
	3-20	12	12	16QAM	3/4	5160	24	1	6912	1728	≥ 1
	5-20	15	12	16QAM	1/2	4264	24	1	8640	2160	≥ 1
	5-20	16	12	16QAM	1/2	4584	24	1	9216	2304	≥ 1
	5-20	18	12	16QAM	1/2	5160	24	1	10368	2592	≥ 1
	5-20	20	12	16QAM	1/3	4008	24	1	11520	2880	≥ 1
	5-20	24	12	16QAM	1/3	4776	24	1	13824	3456	≥ 1
	10-20	25	12	16QAM	1/3	4968	24	1	14400	3600	≥ 1
	10-20	27	12	16QAM	1/3	4776	24	1	15552	3888	≥ 1
	10-20	30	12	16QAM	3/4	12960	24	3	17280	4320	≥ 2
	10-20	32	12	16QAM	3/4	13536	24	3	18432	4608	≥ 2
	10-20	36	12	16QAM	3/4	15264	24	3	20736	5184	≥ 2
	10-20	40	12	16QAM	3/4	16992	24	3	23040	5760	≥ 2
	10-20	45	12	16QAM	3/4	19080	24	4	25920	6480	≥ 2
	10-20	48	12	16QAM	3/4	20616	24	4	27648	6912	≥ 2
	15 - 20	50	12	16QAM	3/4	21384	24	4	28800	7200	≥ 2
	15 - 20	54	12	16QAM	3/4	22920	24	4	31104	7776	≥ 2
	15 - 20	60	12	16QAM	2/3	23688	24	4	34560	8640	≥ 2
	15 - 20	64	12	16QAM	2/3	25456	24	4	36864	9216	≥ 2
	15 - 20	72	12	16QAM	1/2	20616	24	4	41472	10368	≥ 2
	20	75	12	16QAM	1/2	21384	24	4	43200	10800	≥ 2
	20	80	12	16QAM	1/2	22920	24	4	46080	11520	≥ 2
	20	81	12	16QAM	1/2	22920	24	4	46656	11664	≥ 2
	20	90	12	16QAM	2/5	20616	24	4	51840	12960	≥ 2
	20	96	12	16QAM	2/5	22152	24	4	55296	13824	≥ 2

Note 1: If more than one Code Block is present, an additional CRC sequence of L = 24 Bits is attached to each Code Block (otherwise L = 0 Bit)

Table A.2.2.2-1a Reference Channels for 16-QAM with partial RB allocation for UE UL category 0

Parameter	Ch BW	Allocated RBs	DFT-OFDM Symbols per Sub-Frame	Mod'n	Target Coding rate	Payload size	Transport block CRC	Number of code blocks per Sub-Frame (Note 1)	Total number of bits per Sub-Frame	Total symbols per Sub-Frame	UE UL Category
Unit	MHz					Bits	Bits		Bits		
	1.4 - 20	1	12	16QAM	3/4	408	24	1	576	144	0
	1.4 - 20	2	12	16QAM	3/4	840	24	1	1152	288	0
	1.4 - 20	4	12	16QAM	2/5	904	24	1	2304	576	0

Note 1: If more than one Code Block is present, an additional CRC sequence of L = 24 Bits is attached to each Code Block (otherwise L = 0 Bit)

Note 2: For HD-FDD UE, the uplink subframes are scheduled at the 4th, 5th, 6th, 12th, 13th, 14th, 20th, 21st, 22nd, 28th, 29th, 30th, 36th, 37th, and 38th subframes every 40ms. Information bit payload is available if uplink subframe is scheduled.

A.2.2.2.3 64-QAM

[FFS]

A.2.2.3 Void

Table A.2.2.3-1: Void

A.2.3 Reference measurement channels for TDD

For TDD, the measurement channel is based on DL/UL configuration ratio of 2DL:2UL.

A.2.3.1 Full RB allocation

A.2.3.1.1 QPSK

Table A.2.3.1.1-1 Reference Channels for QPSK with full RB allocation

Parameter	Unit	Value					
Channel bandwidth	MHz	1.4	3	5	10	15	20
Allocated resource blocks		6	15	25	50	75	100
Uplink-Downlink Configuration (Note 2)		1	1	1	1	1	1
DFT-OFDM Symbols per Sub-Frame		12	12	12	12	12	12
Modulation		QPSK	QPSK	QPSK	QPSK	QPSK	QPSK
Target Coding rate		1/3	1/3	1/3	1/3	1/5	1/6
Payload size							
For Sub-Frame 2,3,7,8	Bits	600	1544	2216	5160	4392	4584
Transport block CRC	Bits	24	24	24	24	24	24
Number of code blocks per Sub-Frame (Note 1)							
For Sub-Frame 2,3,7,8		1	1	1	1	1	1
Total number of bits per Sub-Frame							
For Sub-Frame 2,3,7,8	Bits	1728	4320	7200	14400	21600	28800
Total symbols per Sub-Frame							
For Sub-Frame 2,3,7,8		864	2160	3600	7200	10800	14400
UE Category		≥ 1	≥ 1	≥ 1	≥ 1	≥ 1	≥ 1
Note 1:	If more than one Code Block is present, an additional CRC sequence of L = 24 Bits is attached to each Code Block (otherwise L = 0 Bit)						
Note 2:	As per Table 4.2-2 in TS 36.211 [4]						

Table A.2.3.1.1-1a Reference Channels for QPSK with full/maximum RB allocation for UE UL category 0

Parameter	Unit	Value					
		1.4	3	5	10	15	20
Channel bandwidth	MHz	1.4	3	5	10	15	20
Allocated resource blocks		6	15	25	36	36	36
Uplink-Downlink Configuration (Note 2)		1	1	1	1	1	1
DFT-OFDM Symbols per Sub-Frame		12	12	12	12	12	12
Modulation		QPSK	QPSK	QPSK	QPSK	QPSK	QPSK
Target Coding rate		1/3	1/5	1/8	1/10	1/10	1/10
Payload size							
For Sub-Frame 2,3,7,8	Bits	600	872	904	1000	1000	1000
Transport block CRC	Bits	24	24	24	24	24	24
Number of code blocks per Sub-Frame (Note 1)							
For Sub-Frame 2,3,7,8		1	1	1	1	1	1
Total number of bits per Sub-Frame							
For Sub-Frame 2,3,7,8	Bits	1728	4320	7200	[10368	10368	10368
Total symbols per Sub-Frame							
For Sub-Frame 2,3,7,8		864	2160	3600	5184	5184	5184
UE UL Category		0	0	0	0	0	0
NOTE 1: If more than one Code Block is present, an additional CRC sequence of L = 24 Bits is attached to each Code Block (otherwise L = 0 Bit)							
NOTE 2: As per Table 4.2-2 in TS 36.211							

A.2.3.1.2 16-QAM**Table A.2.3.1.2-1 Reference Channels for 16-QAM with full RB allocation**

Parameter	Unit	Value					
		1.4	3	5	10	15	20
Channel bandwidth	MHz	1.4	3	5	10	15	20
Allocated resource blocks		6	15	25	50	75	100
Uplink-Downlink Configuration (Note 2)		1	1	1	1	1	1
DFT-OFDM Symbols per Sub-Frame		12	12	12	12	12	12
Modulation		16QAM	16QAM	16QAM	16QAM	16QAM	16QAM
Target Coding rate		3/4	1/2	1/3	3/4	1/2	1/3
Payload size							
For Sub-Frame 2,3,7,8	Bits	2600	4264	4968	21384	21384	19848
Transport block CRC	Bits	24	24	24	24	24	24
Number of code blocks per Sub-Frame (Note 1)							
For Sub-Frame 2,3,7,8		1	1	1	4	4	4
Total number of bits per Sub-Frame							
For Sub-Frame 2,3,7,8	Bits	3456	8640	14400	28800	43200	57600
Total symbols per Sub-Frame							
For Sub-Frame 2,3,7,8		864	2160	3600	7200	10800	14400
UE Category		≥ 1	≥ 1	≥ 1	≥ 2	≥ 2	≥ 2
Note 1: If more than one Code Block is present, an additional CRC sequence of L = 24 Bits is attached to each Code Block (otherwise L = 0 Bit)							
Note 2: As per Table 4.2-2 in TS 36.211 [4]							

Table A.2.3.1.2-1a Reference Channels for 16-QAM with maximum RB allocation for UE UL category 0

Parameter	Unit	Value					
		1.4	3	5	10	15	20
Channel bandwidth	MHz	1.4	3	5	10	15	20
Allocated resource blocks		5	5	5	5	5	5
Uplink-Downlink Configuration (Note 2)		1	1	1	1	1	1
DFT-OFDM Symbols per Sub-Frame		12	12	12	12	12	12
Modulation		16QAM	16QAM	16QAM	16QAM	16QAM	16QAM
Target Coding rate		1/3	1/3	1/3	1/3	1/3	1/3
Payload size							
For Sub-Frame 2,3,7,8	Bits	872	872	872	872	872	872
Transport block CRC	Bits	24	24	24	24	24	24
Number of code blocks per Sub-Frame (Note 1)							
For Sub-Frame 2,3,7,8		1	1	1	1	1	1
Total number of bits per Sub-Frame							
For Sub-Frame 2,3,7,8	Bits	2880	2880	2880	2880	2880	2880
Total symbols per Sub-Frame							
For Sub-Frame 2,3,7,8		720	720	720	720	720	720
UE UL Category		0	0	0	0	0	0
NOTE 1: If more than one Code Block is present, an additional CRC sequence of L = 24 Bits is attached to each Code Block (otherwise L = 0 Bit)							
NOTE 2: As per Table 4.2-2 in TS 36.211[4]							

A.2.3.1.3 64-QAM

[FFS]

A.2.3.2 Partial RB allocation

For each channel bandwidth, various partial RB allocations are specified. The number of allocated RBs is chosen according to values specified in the Tx and Rx requirements. The single allocated RB case is included.

The allocated RBs are contiguous and start from one end of the channel bandwidth. A single allocated RB is at one end of the channel bandwidth.

A.2.3.2.1 QPSK

Table A.2.3.2.1-1 Reference Channels for QPSK with partial RB allocation

Parameter	Ch BW	Allocated RBs	UDL Configuration (Note 2)	DFT-OFDM Symbols per Sub-Frame	Mod'n	Target Coding rate	Payload size for Sub-Frame 2, 3, 7, 8	Transport block CRC	Number of code blocks per Sub-Frame (Note 1)	Total number of bits per Sub-Frame for Sub-Frame 2, 3, 7, 8	Total symbols per Sub-Frame for Sub-Frame 2, 3, 7, 8	UE Category
Unit	MHz						Bits	Bits		Bits		
	1.4 - 20	1	1	12	QPSK	1/3	72	24	1	288	144	≥ 1
	1.4 - 20	2	1	12	QPSK	1/3	176	24	1	576	288	≥ 1
	1.4 - 20	3	1	12	QPSK	1/3	256	24	1	864	432	≥ 1
	1.4 - 20	4	1	12	QPSK	1/3	392	24	1	1152	576	≥ 1
	1.4 - 20	5	1	12	QPSK	1/3	424	24	1	1440	720	≥ 1
	3-20	6	1	12	QPSK	1/3	600	24	1	1728	864	≥ 1
	3-20	8	1	12	QPSK	1/3	808	24	1	2304	1152	≥ 1
	3-20	9	1	12	QPSK	1/3	776	24	1	2592	1296	≥ 1
	3-20	10	1	12	QPSK	1/3	872	24	1	2880	1440	≥ 1
	3-20	12	1	12	QPSK	1/3	1224	24	1	3456	1728	≥ 1
	5-20	15	1	12	QPSK	1/3	1320	24	1	4320	2160	≥ 1
	5-20	16	1	12	QPSK	1/3	1384	24	1	4608	2304	≥ 1
	5-20	18	1	12	QPSK	1/3	1864	24	1	5184	2592	≥ 1
	5-20	20	1	12	QPSK	1/3	1736	24	1	5760	2880	≥ 1
	5-20	24	1	12	QPSK	1/3	2472	24	1	6912	3456	≥ 1
	10-20	25	1	12	QPSK	1/3	2216	24	1	7200	3600	≥ 1
	10-20	27	1	12	QPSK	1/3	2792	24	1	7776	3888	≥ 1
	10-20	30	1	12	QPSK	1/3	2664	24	1	8640	4320	≥ 1
	10-20	32	1	12	QPSK	1/3	2792	24	1	9216	4608	≥ 1
	10-20	36	1	12	QPSK	1/3	3752	24	1	10368	5184	≥ 1
	10-20	40	1	12	QPSK	1/3	4136	24	1	11520	5760	≥ 1
	10-20	45	1	12	QPSK	1/3	4008	24	1	12960	6480	≥ 1
	10-20	48	1	12	QPSK	1/3	4264	24	1	13824	6912	≥ 1
	15 - 20	50	1	12	QPSK	1/3	5160	24	1	14400	7200	≥ 1
	15 - 20	54	1	12	QPSK	1/3	4776	24	1	15552	7776	≥ 1
	15 - 20	60	1	12	QPSK	1/4	4264	24	1	17280	8640	≥ 1
	15 - 20	64	1	12	QPSK	1/4	4584	24	1	18432	9216	≥ 1
	15 - 20	72	1	12	QPSK	1/4	5160	24	1	20736	10368	≥ 1
	20	75	1	12	QPSK	1/5	4392	24	1	21600	10800	≥ 1
	20	80	1	12	QPSK	1/5	4776	24	1	23040	11520	≥ 1
	20	81	1	12	QPSK	1/5	4776	24	1	23328	11664	≥ 1
	20	90	1	12	QPSK	1/6	4008	24	1	25920	12960	≥ 1
	20	96	1	12	QPSK	1/6	4264	24	1	27648	13824	≥ 1
Note 1:	If more than one Code Block is present, an additional CRC sequence of L = 24 Bits is attached to each Code Block (otherwise L = 0 Bit)											
Note 2:	As per Table 4.2-2 in TS 36.211 [4]											

Table A.2.3.2.1-1a Reference Channels for QPSK with partial RB allocation for UE UL category 0

Parameter	Ch BW	Allocated RBs	UDL Configuration (Note 2)	DFT-OFDM Symbols per Sub-Frame	Mod'n	Target Coding rate	Payload size for Sub-Frame 2, 3, 7, 8	Transport block CRC	Number of code blocks per Sub-Frame (Note 1)	Total number of bits per Sub-Frame for Sub-Frame 2, 3, 7, 8	Total symbols per Sub-Frame for Sub-Frame 2, 3, 7, 8	UE UL Category
Unit	MHz						Bits	Bits		Bits		
	1.4 - 20	1	1	12	QPSK	1/3	72	24	1	288	144	0
	1.4 - 20	2	1	12	QPSK	1/3	176	24	1	576	288	0
	1.4 - 20	3	1	12	QPSK	1/3	256	24	1	864	432	0
	1.4 - 20	4	1	12	QPSK	1/3	392	24	1	1152	576	0
	1.4 - 20	5	1	12	QPSK	1/3	424	24	1	1440	720	0
	3-20	6	1	12	QPSK	1/3	600	24	1	1728	864	0
	3-20	8	1	12	QPSK	1/3	808	24	1	2304	1152	0
	3-20	9	1	12	QPSK	1/3	776	24	1	2592	1296	0
	3-20	10	1	12	QPSK	1/3	872	24	1	2880	1440	0
	3-20	12	1	12	QPSK	1/4	840	24	1	3456	1728	0
	5-20	15	1	12	QPSK	1/5	872	24	1	4320	2160	0
	5-20	16	1	12	QPSK	1/5	904	24	1	4608	2304	0
	5-20	18	1	12	QPSK	1/6	776	24	1	5184	2592	0
	5-20	20	1	12	QPSK	1/6	872	24	1	5760	2880	0
	5-20	24	1	12	QPSK	1/8	872	24	1	6912	3456	0
	10-20	25	1	12	QPSK	1/8	904	24	1	7200	3600	0
	10-20	27	1	12	QPSK	1/8	968	24	1	7776	3888	0
	10-20	30	1	12	QPSK	1/10	808	24	1	8640	4320	0

Note 1: If more than one Code Block is present, an additional CRC sequence of L = 24 Bits is attached to each Code Block (otherwise L = 0 Bit)

Note 2: As per Table 4.2-2 in TS 36.211 [4]

A.2.3.2.2 16-QAM

Table A.2.3.2.2-1 Reference Channels for 16QAM with partial RB allocation

Parameter	Ch BW	Allocated RBs	UDL Configuration (Note 2)	DFT-OFDM Symbols per Sub-Frame	Mod'n	Target Coding rate	Payload size for Sub-Frame 2, 3, 7, 8	Transport block CRC	Number of code blocks per Sub-Frame (Note 1)	Total number of bits per Sub-Frame for Sub-Frame 2, 3, 7, 8	Total symbols per Sub-Frame for Sub-Frame 2, 3, 7, 8	UE Category
Unit	MHz						Bits	Bits		Bits		
	1.4 - 20	1	1	12	16QAM	3/4	408	24	1	576	144	≥ 1
	1.4 - 20	2	1	12	16QAM	3/4	840	24	1	1152	288	≥ 1
	1.4 - 20	3	1	12	16QAM	3/4	1288	24	1	1728	432	≥ 1
	1.4 - 20	4	1	12	16QAM	3/4	1736	24	1	2304	576	≥ 1
	1.4 - 20	5	1	12	16QAM	3/4	2152	24	1	2880	720	≥ 1
	3-20	6	1	12	16QAM	3/4	2600	24	1	3456	864	≥ 1
	3-20	8	1	12	16QAM	3/4	3496	24	1	4608	1152	≥ 1
	3-20	9	1	12	16QAM	3/4	3880	24	1	5184	1296	≥ 1
	3-20	10	1	12	16QAM	3/4	4264	24	1	5760	1440	≥ 1
	3-20	12	1	12	16QAM	3/4	5160	24	1	6912	1728	≥ 1
	5-20	15	1	12	16QAM	1/2	4264	24	1	8640	2160	≥ 1
	5-20	16	1	12	16QAM	1/2	4584	24	1	9216	2304	≥ 1
	5-20	18	1	12	16QAM	1/2	5160	24	1	10368	2592	≥ 1
	5-20	20	1	12	16QAM	1/3	4008	24	1	11520	2880	≥ 1
	5-20	24	1	12	16QAM	1/3	4776	24	1	13824	3456	≥ 1
	10-20	25	1	12	16QAM	1/3	4968	24	1	14400	3600	≥ 1
	10-20	27	1	12	16QAM	1/3	4776	24	1	15552	3888	≥ 1
	10-20	30	1	12	16QAM	3/4	12960	24	3	17280	4320	≥ 2
	10-20	32	1	12	16QAM	3/4	13536	24	3	18432	4608	≥ 2
	10-20	36	1	12	16QAM	3/4	15264	24	3	20736	5184	≥ 2
	10-20	40	1	12	16QAM	3/4	16992	24	3	23040	5760	≥ 2
	10-20	45	1	12	16QAM	3/4	19080	24	4	25920	6480	≥ 2
	10-20	48	1	12	16QAM	3/4	20616	24	4	27648	6912	≥ 2
	15 - 20	50	1	12	16QAM	3/4	21384	24	4	28800	7200	≥ 2
	15 - 20	54	1	12	16QAM	3/4	22920	24	4	31104	7776	≥ 2
	15 - 20	60	1	12	16QAM	2/3	23688	24	4	34560	8640	≥ 2
	15 - 20	64	1	12	16QAM	2/3	25456	24	4	36864	9216	≥ 2
	15 - 20	72	1	12	16QAM	1/2	20616	24	4	41472	10368	≥ 2
	20	75	1	12	16QAM	1/2	21384	24	4	43200	10800	≥ 2
	20	80	1	12	16QAM	1/2	22920	24	4	46080	11520	≥ 2
	20	81	1	12	16QAM	1/2	22920	24	4	46656	11664	≥ 2
	20	90	1	12	16QAM	2/5	20616	24	4	51840	12960	≥ 2
	20	96	1	12	16QAM	2/5	22152	24	4	55296	13824	≥ 2

Note 1: If more than one Code Block is present, an additional CRC sequence of L = 24 Bits is attached to each Code Block (otherwise L = 0 Bit)
 Note 2: As per Table 4.2-2 in TS 36.211 [4]

Table A.2.3.2.2-1a Reference Channels for 16QAM with partial RB allocation UE UL category 0

Parameter	Ch BW	Allocated RBs	UDL Configuration (Note 2)	DFT-OFDM Symbols per Sub-Frame	Mod'n	Target Coding rate	Payload size for Sub-Frame 2, 3, 7, 8	Transport block CRC	Number of code blocks per Sub-Frame (Note 1)	Total number of bits per Sub-Frame for Sub-Frame 2, 3, 7, 8	Total symbols per Sub-Frame for Sub-Frame 2, 3, 7, 8	UE UL Category
Unit	MHz						Bits	Bits		Bits		
	1.4 - 20	1	1	12	16QAM	3/4	408	24	1	576	144	0
	1.4 - 20	2		12	16QAM	3/4	840	24	1	1152	288	0
	1.4 - 20	4		12	16QAM	2/5	904	24	1	2304	576	0

Note 1: If more than one Code Block is present, an additional CRC sequence of L = 24 Bits is attached to each Code Block (otherwise L = 0 Bit)
 Note 2: As per Table 4.2-2 in TS 36.211 [4]

A.2.3.2.3 64-QAM

[FFS]

A.2.3.3 Void

Table A.2.3.3-1: Void

A.3 DL reference measurement channels

A.3.1 General

The number of available channel bits varies across the sub-frames due to PBCH and PSS/SSS overhead. The payload size per sub-frame is varied in order to keep the code rate constant throughout a frame.

No user data is scheduled on subframes #5 in order to facilitate the transmission of system information blocks (SIB).

The algorithm for determining the payload size A is as follows; given a desired coding rate R and radio block allocation N_{RB}

1. Calculate the number of channel bits N_{ch} that can be transmitted during the first transmission of a given sub-frame.
2. Find A such that the resulting coding rate is as close to R as possible, that is,

$$\min \left| R - (A + 24 * (N_{CB} + 1)) / N_{ch} \right|, \text{ where } N_{CB} = \begin{cases} 0, & \text{if } C = 1 \\ C, & \text{if } C > 1 \end{cases}$$

subject to

- a) A is a valid TB size according to section 7.1.7 of TS 36.213 [6] assuming an allocation of N_{RB} resource blocks.
 - b) C is the number of Code Blocks calculated according to section 5.1.2 of TS 36.212 [5].
3. If there is more than one A that minimizes the equation above, then the larger value is chosen per default and the chosen code rate should not exceed 0.93.
 4. For TDD, the measurement channel is based on DL/UL configuration ratio of 2DL+DwPTS (12 OFDM symbol):
2UL

A.3.1.1 Overview of DL reference measurement channels

In Table A.3.1.1-1 to A.3.1.1-1Q are listed the DL reference measurement channels specified in annexes A.3.2 to A.3.10 of this release of TS 36.101. This table is informative and serves only to a better overview. The reference for the concrete reference measurement channels and corresponding implementation's parameters as to be used for requirements are annexes A.3.2 to A.3.10 as appropriate.

Table A.3.1.1-1: Overview of DL reference measurement channels (FDD, Receiver requirements)

Duplex	Table	Name	BW	Mod	TCR	RB	RB Off set	UE Cat eg	Notes
FDD	Table A.3.2-1		1.4	QPSK	1/3	6		≥ 1	
FDD	Table A.3.2-1		3	QPSK	1/3	15		≥ 1	
FDD	Table A.3.2-1		5	QPSK	1/3	25		≥ 1	
FDD	Table A.3.2-1		10	QPSK	1/3	50		≥ 1	
FDD	Table A.3.2-1		15	QPSK	1/3	75		≥ 1	
FDD	Table A.3.2-1		20	QPSK	1/3	100		≥ 1	
FDD / HD-FDD	Table A.3.2-1a		1.4	QPSK	1/3	6		-	UE DL Category 0
FDD / HD-FDD	Table A.3.2-1a		3	QPSK	1/3	14		-	UE DL Category 0
FDD / HD-FDD	Table A.3.2-1a		5	QPSK	1/3	14		-	UE DL Category 0
FDD / HD-FDD	Table A.3.2-1a		10	QPSK	1/3	14		-	UE DL Category 0
FDD / HD-FDD	Table A.3.2-1a		15	QPSK	1/3	14		-	UE DL Category 0
FDD / HD-FDD	Table A.3.2-1a		20	QPSK	1/3	14		-	UE DL Category 0

Table A.3.1.1-1A: Overview of DL reference measurement channels (TDD, Receiver requirements)

Duplex	Table	Name	BW	Mod	TCR	RB	RB Off set	UE Cat eg	Notes
TDD	Table A.3.2-2		1.4	QPSK	1/3	6		≥ 1	
TDD	Table A.3.2-2		3	QPSK	1/3	15		≥ 1	
TDD	Table A.3.2-2		5	QPSK	1/3	25		≥ 1	
TDD	Table A.3.2-2		10	QPSK	1/3	50		≥ 1	
TDD	Table A.3.2-2		15	QPSK	1/3	75		≥ 1	
TDD	Table A.3.2-2		20	QPSK	1/3	100		≥ 1	
TDD	Table A.3.2-2a		1.4	QPSK	1/3	6		-	UE DL Category 0
TDD	Table A.3.2-2a		3	QPSK	1/3	14		-	UE DL Category 0
TDD	Table A.3.2-2a		5	QPSK	1/3	14		-	UE DL Category 0
TDD	Table A.3.2-2a		10	QPSK	1/3	14		-	UE DL Category 0
TDD	Table A.3.2-2a		15	QPSK	1/3	14		-	UE DL Category 0
-	Table A.3.2-2a		20	QPSK	1/3	14		-	UE DL Category 0

Table A.3.1.1-1B: Overview of DL reference measurement channels (FDD, Receiver requirements, Maximum input level)

Duplex	Table	Name	BW	Mod	TCR	RB	RB Off set	UE Cat eg	Notes
UE Categories ≥ 3									
FDD	Table A.3.2-3		1.4	64QAM	3/4	6		-	
FDD	Table A.3.2-3		3	64QAM	3/4	15		-	
FDD	Table A.3.2-3		5	64QAM	3/4	25		-	
FDD	Table A.3.2-3		10	64QAM	3/4	50		-	
FDD	Table A.3.2-3		15	64QAM	3/4	75		-	
FDD	Table A.3.2-3		20	64QAM	3/4	100		-	
UE Categories 1									
FDD	Table A.3.2-3a		1.4	64QAM	3/4	6		-	
FDD	Table A.3.2-3a		3	64QAM	3/4	15		-	
FDD	Table A.3.2-3a		5	64QAM	3/4	18		-	
FDD	Table A.3.2-3a		10	64QAM	3/4	17		-	
FDD	Table A.3.2-3a		15	64QAM	3/4	17		-	
FDD	Table A.3.2-3a		20	64QAM	3/4	17		-	
UE Categories 2									
FDD	Table A.3.2-3b		1.4	64QAM	3/4	6		-	
FDD	Table A.3.2-3b		3	64QAM	3/4	15		-	
FDD	Table A.3.2-3b		5	64QAM	3/4	25		-	
FDD	Table A.3.2-3b		10	64QAM	3/4	50		-	
FDD	Table A.3.2-3b		15	64QAM	3/4	75		-	
FDD	Table A.3.2-3b		20	64QAM	3/4	83		-	
UE DL Categories 0									
FDD	Table A.3.2-3c		1.4	64QAM	3/4	2		-	
FDD	Table A.3.2-3c		3	64QAM	3/4	2		-	
FDD	Table A.3.2-3c		5	64QAM	3/4	2		-	
FDD	Table A.3.2-3c		10	64QAM	3/4	2		-	
FDD	Table A.3.2-3c		15	64QAM	3/4	2		-	
FDD	Table A.3.2-3c		20	64QAM	3/4	2		-	

Table A.3.1.1-1C: Overview of DL reference measurement channels (TDD, Receiver requirements, Maximum input level)

Duplex	Table	Name	BW	Mod	TCR	RB	RB Off set	UE Cat eg	Notes
UE Categories ≥ 3									
TDD	Table A.3.2-4		1.4	64QAM	3/4	6		-	
TDD	Table A.3.2-4		3	64QAM	3/4	15		-	
TDD	Table A.3.2-4		5	64QAM	3/4	25		-	
TDD	Table A.3.2-4		10	64QAM	3/4	50		-	
TDD	Table A.3.2-4		15	64QAM	3/4	75		-	
TDD	Table A.3.2-4		20	64QAM	3/4	100		-	
UE Categories 1									
TDD	Table A.3.2-4a		1.4	64QAM	3/4	6		-	
TDD	Table A.3.2-4a		3	64QAM	3/4	15		-	
TDD	Table A.3.2-4a		5	64QAM	3/4	18		-	
TDD	Table A.3.2-4a		10	64QAM	3/4	17		-	
TDD	Table A.3.2-4a		15	64QAM	3/4	17		-	
TDD	Table A.3.2-4a		20	64QAM	3/4	17		-	
UE Categories 2									
TDD	Table A.3.2-4b		1.4	64QAM	3/4	6		-	
TDD	Table A.3.2-4b		3	64QAM	3/4	15		-	
TDD	Table A.3.2-4b		5	64QAM	3/4	25		-	
TDD	Table A.3.2-4b		10	64QAM	3/4	50		-	
TDD	Table A.3.2-4b		15	64QAM	3/4	75		-	
TDD	Table A.3.2-4b		20	64QAM	3/4	83		-	
UE DL Categories 0									
TDD	Table A.3.2-4c		1.4	64QAM	3/4	2		-	
TDD	Table A.3.2-4c		3	64QAM	3/4	2		-	
TDD	Table A.3.2-4c		5	64QAM	3/4	2		-	
TDD	Table A.3.2-4c		10	64QAM	3/4	2		-	
TDD	Table A.3.2-4c		15	64QAM	3/4	2		-	
TDD	Table A.3.2-4c		20	64QAM	3/4	2		-	
UE Categories 11/12 and UE DL categories ≥ 11									
FDD	Table A.3.2-5		1.4	256QAM	4/5	6		-	
FDD	Table A.3.2-5		3	256QAM	4/5	15		-	
FDD	Table A.3.2-5		5	256QAM	4/5	25		-	
FDD	Table A.3.2-5		10	256QAM	4/5	50		-	
FDD	Table A.3.2-5		15	256QAM	4/5	75		-	
FDD	Table A.3.2-5		20	256QAM	4/5	100		-	
UE Categories 11/12 and UE DL categories ≥ 11									
TDD	Table A.3.2-6		1.4	256QAM	4/5	6		-	
TDD	Table A.3.2-6		3	256QAM	4/5	15		-	
TDD	Table A.3.2-6		5	256QAM	4/5	25		-	
TDD	Table A.3.2-6		10	256QAM	4/5	50		-	
TDD	Table A.3.2-6		15	256QAM	4/5	75		-	
TDD	Table A.3.2-6		20	256QAM	4/5	100		-	

Table A.3.1.1-1D: Overview of DL reference measurement channels (FDD, PDSCH Performance, Single-antenna transmission (CRS))

Duplex	Table	Name	BW	Mod	TCR	RB	RB Off set	UE Cat eg	Notes
FDD	Table A.3.3.1-1	R.4 FDD	1.4	QPSK	1/3	6		≥ 1	
FDD	Table A.3.3.1-1	R.42 FDD	20	QPSK	1/3	100		≥ 1	
FDD	Table A.3.3.1-1	R.42-1 FDD	3	QPSK	1/3	15		≥ 1	
FDD	Table A.3.3.1-1	R.42-2 FDD	5	QPSK	1/3	25		≥ 1	
FDD	Table A.3.3.1-1	R.42-3 FDD	15	QPSK	1/3	75		≥ 1	
FDD	Table A.3.3.1-1	R.2 FDD	10	QPSK	1/3	50		≥ 1	
FDD	Table A.3.3.1-2	R.3-1 FDD	5	16QAM	1/2	25		≥ 1	
FDD	Table A.3.3.1-2	R.3 FDD	10	16QAM	1/2	50		≥ 2	
FDD	Table A.3.3.1-3	R.5 FDD	3	64QAM	3/4	15		≥ 1	
FDD	Table A.3.3.1-3	R.6 FDD	5	64QAM	3/4	25		≥ 2	
FDD	Table A.3.3.1-3	R.7 FDD	10	64QAM	3/4	50		≥ 2	
FDD	Table A.3.3.1-3	R.8 FDD	15	64QAM	3/4	75		≥ 2	
FDD	Table A.3.3.1-3	R.9 FDD	20	64QAM	3/4	100		≥ 3	
FDD	Table A.3.3.1-3a	R.6-1 FDD	5	64QAM	3/4	18		≥ 1	
FDD	Table A.3.3.1-3a	R.7-1 FDD	10	64QAM	3/4	17		≥ 1	
FDD	Table A.3.3.1-3a	R.8-1 FDD	15	64QAM	3/4	17		≥ 1	
FDD	Table A.3.3.1-3a	R.9-1 FDD	20	64QAM	3/4	17		≥ 1	
FDD	Table A.3.3.1-3a	R.9-2 FDD	20	64QAM	3/4	83		≥ 2	
FDD	Table A.3.3.1-6	R.41 FDD	10	QPSK	1/10	50		≥ 1	
Single PRB (Channel edge)									
FDD	Table A.3.3.1-4	R.0 FDD	3	16QAM	1/2	1		≥ 1	
FDD	Table A.3.3.1-4	R.1 FDD	10/ 20	16QAM	1/2	1		≥ 1	
Single PRB (MBSFN Configuration)									
FDD	Table A.3.3.1-5	R.29 FDD	10	16QAM	1/2	1		≥ 1	

Table A.3.1.1-1E: Overview of DL reference measurement channels (PDSCH Performance: Carrier aggregation with power imbalance)

Duplex	Table	Name	BW	Mod	TCR	RB	RB Off set	UE Cat eg	Notes
FDD									
FDD	Table A.3.3.1-7	R.49 FDD	20	64QAM	0.84- 0.87	100		≥ 5	
FDD	Table A.3.3.1-7	R.49-1 FDD	10	64QAM	0.84- 0.87	50		≥ 2	
FDD	Table A.3.3.1-7	R.49-2 FDD	5	64QAM	0.84- 0.86	25		≥ 2	
TDD									
TDD	Table A.3.4.1-7	R.49 TDD	20	64QAM	0.81- 0.87	100		≥ 5	
TDD	Table A.3.4.1-7	R.49-1 TDD	15	64QAM	0.80- 0.86	75		≥ 3	

Table A.3.1.1-1F: Overview of DL reference measurement channels (FDD, PDSCH Performance, Multi-antenna transmission (CRS))

Duplex	Table	Name	BW	Mod	TCR	RB	RB Off set	UE Cat eg	Notes
Two antenna ports									
FDD	Table A.3.3.2.1-1	R.10 FDD	10	QPSK	1/3	50		≥ 1	
FDD	Table A.3.3.2.1-1	R.11 FDD	10	16QAM	1/2	50		≥ 2	
FDD	Table A.3.3.2.1-1	R.11-1 FDD	10	16QAM	1/2	50		≥ 2	
FDD	Table A.3.3.2.1-1	R.11-2 FDD	5	16QAM	1/2	25		≥ 1	
FDD	Table A.3.3.2.1-1	R.11-3 FDD	10	16QAM	1/2	40		≥ 1	
FDD	Table A.3.3.2.1-1	R.11-4 FDD	10	QPSK	1/2	50		≥ 1	
FDD	Table A.3.3.2.1-1	R.30 FDD	20	16QAM	1/2	100		≥ 2	
FDD	Table A.3.3.2.1-1	R.30-1 FDD	15	16QAM	1/2	75		≥ 2	
FDD	Table A.3.3.2.1-1	R.35 FDD	10	64QAM	1/2	50		≥ 2	
FDD	Table A.3.3.2.1-1	R.35-1 FDD	20	64QAM	0.39	100		4	
FDD	Table A.3.3.2.1-1	R.35-2 FDD	15	64QAM	0.39	75		≥ 2	
FDD	Table A.3.3.2.1-1	R.35-3 FDD	10	64QAM	0.39	50		≥ 2	
FDD	Table A.3.3.2.1-2	R.35-4 FDD	10	64QAM	0.47	50		≥ 2	
FDD	Table A.3.3.2.1-2	R.46 FDD	10	QPSK		50		≥ 1	
FDD	Table A.3.3.2.1-2	R.47 FDD	10	16QAM		50		≥ 1	
FDD	Table A.3.3.2.1-2	R.11-5 FDD	1.4	16QAM	1/2	6		≥ 1	
FDD	Table A.3.3.2.1-2	R.11-6 FDD	3	16QAM	1/2	15		≥ 1	
FDD	Table A.3.3.2.1-2	R.11-7 FDD	15	16QAM	1/2	75		≥ 2	
FDD	Table A.3.3.2.1-2	R.11-8 FDD	10	QPSK	3/5	50		≥ 2	
FDD	Table A.3.3.2.1-2	R.11-9 FDD	10	QPSK	0.58	50		≥ 1	
FDD	Table A.3.3.2.1-2	R.11-10 FDD	10	QPSK	0.67	50		≥ 1	
FDD	Table A.3.3.2.1-2	R.10-2 FDD	5	QPSK	1/3	25		≥ 1	
FDD	Table A.3.3.2.1-2	R.65 FDD	10	256QAM	0.55	50		11-15	
FDD	Table A.3.3.2.1-3	R. 62 FDD	10	16QAM	1/2	3		0	
FDD	Table A.3.3.2.1-3	R.63 FDD	10	64QAM	1/2	1		0	
Four antenna ports									
FDD	Table A.3.3.2.2-1	R.12 FDD	1.4	QPSK	1/3	6		≥ 1	
FDD	Table A.3.3.2.2-1	R.13 FDD	10	QPSK	1/3	50		≥ 1	
FDD	Table A.3.3.2.2-1	R.14 FDD	10	16QAM	1/2	50		≥ 2	
FDD	Table A.3.3.2.2-1	R.14-1 FDD	10	16QAM	1/2	6		≥ 1	
FDD	Table A.3.3.2.2-1	R.14-2 FDD	10	16QAM	1/2	3		≥ 1	
FDD	Table A.3.3.2.2-1	R.14-3 FDD	20	16QAM	1/2	100		≥ 2	
FDD	Table A.3.3.2.2-1	R.36 FDD	10	64QAM	1/2	50		≥ 2	
FDD	Table A.3.3.2.2-1	R.14-4 FDD	1.4	16QAM	1/2	6		≥ 1	
FDD	Table A.3.3.2.2-1	R.14-5 FDD	3	16QAM	1/2	15		≥ 1	
FDD	Table A.3.3.2.2-1	R.14-6 FDD	5	16QAM	1/2	25		≥ 1	
FDD	Table A.3.3.2.2-1	R.14-7 FDD	15	16QAM	1/2	75		≥ 2	

Table A.3.1.1-1G: Overview of DL reference measurement channels (FDD, PDSCH Performance (UE specific RS))

Duplex	Table	Name	BW	Mod	TCR	RB	RB Off set	UE Cat eg	Notes
Without CSI-RS									
FDD	Table A.3.3.3.0-1	R.70 FDD	10	QPSK	0.65	50		≥ 1	
FDD	Table A.3.3.3.0-1	R.71 FDD	10	16QAM	0.6	50		≥ 2	
Two antenna ports (CSI-RS)									
FDD	Table A.3.3.3.1-1	R.51 FDD	10	16QAM	1/2	50		≥ 2	
Two antenna ports (CSI-RS, non Quasi Co-located)									
FDD	Table A.3.3.3.1-2	R.52 FDD	10	64QAM	1/2	50		≥ 2	
FDD	Table A.3.3.3.1-2	R.53 FDD	10	64QAM	1/2	50		≥ 2	
FDD	Table A.3.3.3.1-2	R.54 FDD	10	16QAM	1/2	50		≥ 2	
Four antenna ports (CSI-RS)									
FDD	Table A.3.3.3.2-1	R.43 FDD	10	QPSK	1/3	50		≥ 1	
FDD	Table A.3.3.3.2-1	R.50 FDD	10	64QAM	1/2	50		≥ 2	
FDD	Table A.3.3.3.2-2	R.44 FDD	10	QPSK	1/3	50		≥ 1	
FDD	Table A.3.3.3.2-2	R.45 FDD	10	16QAM	1/2	50		≥ 2	
FDD	Table A.3.3.3.2-2	R.45-1 FDD	10	16QAM	1/2	39		≥ 1	
FDD	Table A.3.3.3.2-1	R.48 FDD	10	QPSK		50		≥ 1	
FDD	Table A.3.3.3.2-2	R.60 FDD	10	QPSK	1/2	50		≥ 1	
FDD	Table A.3.3.3.2-3	R.64 FDD	10	QPSK	1/3	6		0	
FDD	Table A.3.3.3.2-1	R.66 FDD	10	256QAM	0.77	50		11-15	
FDD	Table A.3.3.3.2-4	R.69 FDD	10	QPSK	0.74-0.8	50		≥ 1	

Table A.3.1.1-1H: Overview of DL reference measurement channels (TDD, PDSCH Performance, Single-antenna transmission (CRS))

Duplex	Table	Name	BW	Mod	TCR	RB	RB Off set	UE Cat eg	Notes
TDD	Table A.3.4.1-1	R.4 TDD	1.4	QPSK	1/3	6		≥ 1	
TDD	Table A.3.4.1-1	R.42 TDD	20	QPSK	1/3	100		≥ 1	
TDD	Table A.3.4.1-1	R.2 TDD	10	QPSK	1/3	50		≥ 1	
TDD	Table A.3.4.1-1	R.2A TDD	10	QPSK	1/3	50		≥ 1	
TDD	Table A.3.4.1-1	R.42-1 TDD	3	QPSK	1/3	15		≥ 1	
TDD	Table A.3.4.1-1	R.42-2 TDD	5	QPSK	1/3	25		≥ 1	
TDD	Table A.3.4.1-1	R.42-3 TDD	15	QPSK	1/3	75		≥ 1	
TDD	Table A.3.4.1-2	R.3-1 TDD	5	16QAM	1/2	25		≥ 1	
TDD	Table A.3.4.1-2	R.3 TDD	10	16QAM	1/2	50		≥ 2	
TDD	Table A.3.4.1-3	R.5 TDD	3	64QAM	3/4	15		≥ 1	
TDD	Table A.3.4.1-3	R.6 TDD	5	64QAM	3/4	25		≥ 2	
TDD	Table A.3.4.1-3	R.7 TDD	10	64QAM	3/4	50		≥ 2	
TDD	Table A.3.4.1-3	R.8 TDD	15	64QAM	3/4	75		≥ 2	
TDD	Table A.3.4.1-3	R.9 TDD	20	64QAM	3/4	100		≥ 3	
TDD	Table A.3.4.1-3a	R.6-1 TDD	5	64QAM	3/4	18		≥ 1	
TDD	Table A.3.4.1-3a	R.7-1 TDD	10	64QAM	3/4	17		≥ 1	
TDD	Table A.3.4.1-3a	R.8-1 TDD	15	64QAM	3/4	17		≥ 1	
TDD	Table A.3.4.1-3a	R.9-1 TDD	20	64QAM	3/4	17		≥ 1	
TDD	Table A.3.4.1-3a	R.9-2 TDD	20	64QAM	3/4	83		≥ 2	
TDD	Table A.3.4.1-6	R.41 TDD	10	QPSK	1/10	50		≥ 1	
Single PRB (Channel edge)									
TDD	Table A.3.4.1-4	R.0 TDD	3	16QAM	1/2	1		≥ 1	
TDD	Table A.3.4.1-4	R.1 TDD	10 / 20	16QAM	1/2	1		≥ 1	
Single PRB (MBSFN Configuration)									
TDD	Table A.3.4.1-5	R.29 TDD	10	16QAM	1/2	1		≥ 1	

Table A.3.1.1-1I: Overview of DL reference measurement channels (TDD, PDSCH Performance, Multi-antenna transmission (CRS))

Duplex	Table	Name	BW	Mod	TCR	RB	RB Off set	UE Cat eg	Notes
Two antenna ports									
TDD	Table A.3.4.2.1-1	R.10 TDD	10	QPSK	1/3	50		≥ 1	
TDD	Table A.3.4.2.1-1	R.11 TDD	10	16QAM	1/2	50		≥ 2	
TDD	Table A.3.4.2.1-1	R.11-1 TDD	10	16QAM	1/2	50		≥ 2	
TDD	Table A.3.4.2.1-1	R.11-2 TDD	5	16QAM	1/2	25		≥ 1	
TDD	Table A.3.4.2.1-1	R.11-3 TDD	10	16QAM	1/2	40		≥ 1	
TDD	Table A.3.4.2.1-1	R.11-4 TDD	10	QPSK	1/2	50		≥ 1	
TDD	Table A.3.4.2.1-1	R.30 TDD	20	16QAM	1/2	100		≥ 2	
TDD	Table A.3.4.2.1-1	R.30-1 TDD	20	16QAM	1/2	100		≥ 2	
TDD	Table A.3.4.2.1-1	R.30-2 TDD	20	16QAM	1/2	100		3	
TDD	Table A.3.4.2.1-1	R.35 TDD	10	64QAM	1/2	50		≥ 2	
TDD	Table A.3.4.2.1-1	R.35-1 TDD	20	64QAM	0.39	100		4	
TDD	Table A.3.4.2.1-2	R.35-2 TDD	10	64QAM	0.47	50		≥ 2	
TDD	Table A.3.4.2.1-2	R.46 TDD	10	QPSK		50		≥ 1	
TDD	Table A.3.4.2.1-2	R.47 TDD	10	16QAM		50		≥ 1	
TDD	Table A.3.4.2.1-2	R.11-5 TDD	1.4	16QAM	1/2	6		≥ 1	
TDD	Table A.3.4.2.1-2	R.11-6 TDD	3	16QAM	1/2	15		≥ 1	
TDD	Table A.3.4.2.1-2	R.11-7 TDD	5	16QAM	1/2	25		≥ 1	
TDD	Table A.3.4.2.1-2	R.11-8 TDD	10	16QAM	1/2	50		≥ 2	
TDD	Table A.3.4.2.1-2	R.11-9 TDD	15	16QAM	1/2	75		≥ 2	
TDD	Table A.3.4.2.1-2	R.11-10 TDD	10	QPSK	3/5	50		≥ 2	
TDD	Table A.3.4.2.1-2	R.11-11 TDD	10	QPSK	0.48-0.58	50		≥ 1	
TDD	Table A.3.4.2.1-2	R.11-12 TDD	10	QPSK	0.54-0.66	50		≥ 1	
TDD	Table A.3.4.2.1-3	R.62 TDD	10	16QAM	1/2	3		0	
TDD	Table A.3.4.2.1-3	R.63 TDD	10	64QAM	1/2	1		0	
TDD	Table A.3.4.2.1-4	R.65 TDD	20	256QAM	0.6	100		11-15	
TDD	Table A.3.4.2.1-5	R.67 TDD	10	16QAM	0.4	50		≥ 1	
Four antenna ports									
TDD	Table A.3.4.2.2-1	R.12 TDD	1.4	QPSK	1/3	6		≥ 1	
TDD	Table A.3.4.2.2-1	R.13 TDD	10	QPSK	1/3	50		≥ 1	
TDD	Table A.3.4.2.2-1	R.14 TDD	10	16QAM	1/2	50		≥ 2	
TDD	Table A.3.4.2.2-1	R.14-1 TDD	10	16QAM	1/2	6		≥ 1	
TDD	Table A.3.4.2.2-1	R.14-2 TDD	10	16QAM	1/2	3		≥ 1	
TDD	Table A.3.4.2.2-1	R.43 TDD	20	16QAM	1/2	100		≥ 2	
TDD	Table A.3.4.2.2-1	R.36 TDD	10	64QAM	1/2	50		≥ 2	
TDD	Table A.3.4.2.2-1	R.43-1 TDD	1.4	16QAM	1/2	6		≥ 1	
TDD	Table A.3.4.2.2-1	R.43-2 TDD	3	16QAM	1/2	15		≥ 1	
TDD	Table A.3.4.2.2-1	R.43-3 TDD	5	16QAM	1/2	25		≥ 1	
TDD	Table A.3.4.2.2-1	R.43-4 TDD	10	16QAM	1/2	50		≥ 2	
TDD	Table A.3.4.2.2-1	R.43-5 TDD	15	16QAM	1/2	75		≥ 2	

Table A.3.1.1-1J: Overview of DL reference measurement channels (TDD, PDSCH Performance (DRS))

Duplex	Table	Name	BW	Mod	TCR	RB	RB Off set	UE Cat eg	Notes
Single antenna port									
TDD	Table A.3.4.3.1-1	R.25 TDD	10	QPSK	1/3	50		≥ 1	
TDD	Table A.3.4.3.1-1	R.26 TDD	10	16QAM	1/2	50		≥ 2	
TDD	Table A.3.4.3.1-1	R.26-1 TDD	5	16QAM	1/2	25		≥ 1	
TDD	Table A.3.4.3.1-1	R.27 TDD	10	64QAM	3/4	50		≥ 2	
TDD	Table A.3.4.3.1-1	R.27-1 TDD	10	64QAM	3/4	18		≥ 1	
TDD	Table A.3.4.3.1-1	R.28 TDD	10	16QAM	1/2	1		≥ 1	
Two antenna ports									
TDD	Table A.3.4.3.2-1	R.31 TDD	10	QPSK	1/3	50		≥ 1	
TDD	Table A.3.4.3.2-1	R.32 TDD	10	16QAM	1/2	50		≥ 2	
TDD	Table A.3.4.3.2-1	R.32-1 TDD	5	16QAM	1/2	[25]		≥ 1	
TDD	Table A.3.4.3.2-1	R.33 TDD	10	64QAM	3/4	50		≥ 2	
TDD	Table A.3.4.3.2-1	R.33-1 TDD	10	64QAM	3/4	[18]		≥ 1	
TDD	Table A.3.4.3.2-1	R.34 TDD	10	64QAM	1/2	50		≥ 2	
TDD	Table A.3.4.3.2	R.70 TDD	10	QPSK	0.54-0.65	50		≥ 1	
TDD	Table A.3.4.3.2	R.71 TDD	10	16QAM	0.5-0.6	50		≥ 2	

Table A.3.1.1-1K: Overview of DL reference measurement channels (TDD, PDSCH Performance (UE specific RS))

Duplex	Table	Name	BW	Mod	TCR	RB	RB Off set	UE Cat eg	Notes
Two antenna ports (CSI-RS)									
TDD	Table A.3.4.3.3-1	R.51 TDD	10	16QAM	1/2	50		≥ 2	
Two antenna ports (CSI-RS, non Quasi Co-located)									
TDD	Table A.3.4.3.3-2	R.52 TDD	10	64QAM	1/2	50		≥ 2	
TDD	Table A.3.4.3.3-2	R.53 TDD	10	64QAM	1/2	50		≥ 2	
TDD	Table A.3.4.3.3-2	R.54 TDD	10	16QAM	1/2	50		≥ 2	
Four antenna ports (CSI-RS)									
TDD	Table A.3.4.3.4-1	R.44 TDD	10	64QAM	1/2	50		≥ 2	
TDD	Table A.3.4.3.4-1	R.48 TDD	10	QPSK		50		≥ 1	
TDD	Table A.3.4.3.4-2	R.60 TDD	10	QPSK	1/2	50		≥ 1	
TDD	Table A.3.4.3.4-2	R.61 TDD	10	16QAM	1/2	50		≥ 2	
TDD	Table A.3.4.3.4-2	R.61-1 TDD	10	16QAM	1/2	39		≥ 1	
TDD	Table A.3.4.3.4-3	R.64 TDD	10	QPSK	1/3	6		0	
TDD	Table A.3.4.3.4-1	R.66 TDD	20	256QAM		100		11-15	
TDD	Table A.3.4.3.4-4	R.69 TDD	10	QPSK	0.61-0.8	50		≥ 1	
Eight antenna ports (CSI-RS)									
TDD	Table A.3.4.3.5-1	R.50 TDD	10	QPSK	1/3	50		≥ 1	
TDD	Table A.3.4.3.5-2	R.45 TDD	10	16QAM	1/2	50		≥ 2	
TDD	Table A.3.4.3.5-2	R.45-1 TDD	10	16QAM	1/2	39		≥ 1	

Table A.3.1.1-1L: Overview of DL reference measurement channels (PDCCH / PCFICH Performance)

Duplex	Table	Name	BW	Mod	TCR	RB	RB Off set	UE Cat eg	Notes
FDD									
FDD	Table A.3.5.1-1	R.15 FDD	10	PDCCH					
FDD	Table A.3.5.1-1	R.15-1 FDD	10	PDCCH					
FDD	Table A.3.5.1-1	R.15-2 FDD	10	PDCCH					
FDD	Table A.3.5.1-1	R.16 FDD	10	PDCCH					
FDD	Table A.3.5.1-1	R.17 FDD	5	PDCCH					
TDD									
TDD	Table A.3.5.2-1	R.15 TDD	10	PDCCH					
TDD	Table A.3.5.2-1	R.15-1 TDD	10	PDCCH					
TDD	Table A.3.5.2-1	R.15-2 TDD	10	PDCCH					
TDD	Table A.3.5.2-1	R.16 TDD	10	PDCCH					
TDD	Table A.3.5.2-1	R.17 TDD	5	PDCCH					

Table A.3.1.1-1M: Overview of DL reference measurement channels (PHICH Performance)

Duplex	Table	Name	BW	Mod	TCR	RB	RB Off set	UE Cat eg	Notes
FDD / TDD	Table A.3.6-1	R.18	10	PHICH					
FDD / TDD	Table A.3.6-1	R.19	10	PHICH					
FDD	Table A.3.6.1	R.19-1	5	PHICH					
FDD / TDD	Table A.3.6-1	R.20	5	PHICH					
FDD / TDD	Table A.3.6-1	R.24	10	PHICH					

Table A.3.1.1-1N: Overview of DL reference measurement channels (PBCH Performance)

Duplex	Table	Name	BW	Mod	TCR	RB	RB Off set	UE Cat eg	Notes
FDD / TDD	Table A.3.7-1	R.21	1.4	QPSK	40/1920				
FDD / TDD	Table A.3.7-1	R.22	1.4	QPSK	40/1920				
FDD / TDD	Table A.3.7-1	R.23	1.4	QPSK	40/1920				

Table A.3.1.1-10: Overview of DL reference measurement channels (PMCH Performance)

Duplex	Table	Name	BW	Mod	TCR	RB	RB Off set	UE Cat eg	Notes
FDD									
FDD	Table A.3.8.1-1	R.40 FDD	1.4	QPSK	1/3	6		≥ 1	
FDD	Table A.3.8.1-1	R.37 FDD	10	QPSK	1/3	50		≥ 1	
FDD	Table A.3.8.1-2	R.38 FDD	10	16QAM	1/2	50		≥ 1	
FDD	Table A.3.8.1-3	R.39-1 FDD	5	64QAM	2/3	25		≥ 1	
FDD	Table A.3.8.1-3	R.39 FDD	10	64QAM	2/3	50		≥ 2	
TDD									
TDD	Table A.3.8.2-1	R.40 TDD	1.4	QPSK	1/3	6		≥ 1	
TDD	Table A.3.8.2-1	R.37 TDD	10	QPSK	1/3	50		≥ 1	
TDD	Table A.3.8.2-2	R.38 TDD	10	16QAM	1/2	50		≥ 1	
TDD	Table A.3.8.2-3	R.39-1 TDD	5	64QAM	2/3	25		≥ 1	
TDD	Table A.3.8.2-3	R.39 TDD	10	64QAM	2/3	50		≥ 2	

Table A.3.1.1-1P: Overview of DL reference measurement channels (Sustained data rate)

Duplex	Table	Name	BW	Mod	TCR	RB	RB Off set	UE Cat eg	Notes
FDD									
FDD	Table A.3.9.1-1	R.31-1 FDD	10	64QAM	0.40			≥ 1	
FDD	Table A.3.9.1-1	R.31-2 FDD	10	64QAM	0.59-0.64			≥ 2	
FDD	Table A.3.9.1-1	R.31-3 FDD	20	64QAM	0.59-0.62			≥ 2	
FDD	Table A.3.9.1-1	R.31-3A FDD	10	64QAM	0.85-0.90			≥ 2	
FDD	Table A.3.9.1-1	R.31-3C FDD	15	64QAM	0.87-0.91			≥ 3	
FDD	Table A.3.9.1-1	R.31-4 FDD	20	64QAM	0.87-0.90			≥ 3	
FDD	Table A.3.9.1-1	R.31-4B FDD	15	64QAM	0.85-0.88			≥ 4	
FDD	Table A.3.9.1-1	R.31-5 FDD	15	64QAM	0.85-0.91			≥ 3	
FDD	Table A.3.9.1-2	R.31-6 FDD	5	64QAM	0.83-0.85			≥ 2	
FDD	Table A.3.9.1-3	R.68 FDD	20	256QAM	0.74-0.85			11-12	
FDD	Table A.3.9.1-3	R.68-1 FDD	15	256QAM	0.74-0.88			11-12	
FDD	Table A.3.9.1-3	R.68-2 FDD	10	256QAM	0.74-0.85			11-12	
FDD	Table A.3.9.1-3	R.68-3 FDD	5	256QAM	0.77-0.85			11-12	
TDD									
TDD	Table A.3.9.2-1	R.31-1 TDD	10	64QAM	0.40			≥ 1	
TDD	Table A.3.9.2-1	R.31-2 TDD	10	64QAM	0.59-0.64			≥ 2	
TDD	Table A.3.9.2-1	R.31-3 TDD	20	64QAM	0.59-0.62			≥ 2	
TDD	Table A.3.9.2-1	R.31-3A TDD	15	64QAM	0.87-0.90			≥ 2	
TDD	Table A.3.9.2-1	R.31-4 TDD	20	64QAM	0.87-0.90			≥ 3	
TDD	Table A.3.9.2-1	R.31-4A TDD	20	64QAM	0.87-0.90			≥ 3	
TDD	Table A.3.9.2-1	R.31-5 TDD	15	64QAM	0.85-0.88			≥ 3	
TDD	Table A.3.9.2-1	R.31-5A TDD	15	64QAM	0.85-0.88			≥ 3	
TDD	Table A.3.9.2-1	R.31-6 TDD	10	64QAM	0.85-0.88			≥ 2	
TDD	Table A.3.9.2-2	R.68 TDD	20	256QAM				11-12	
TDD	Table A.3.9.2-2	R.68-1 TDD	15	256QAM				11-12	
TDD	Table A.3.9.2-2	R.68-2 TDD	10	256QAM				11-12	
TDD	Table A.3.9.2-2	R.68-3 TDD	20	256QAM				11-12	
TDD	Table A.3.9.2-2	R.68-4 TDD	15	256QAM				11-12	
FDD, EPDCCH scheduling									
FDD	Table A.3.9.3-1	R.31E-1 FDD	10	64QAM	0.40-0			≥ 1	
FDD	Table A.3.9.3-1	R.31E-2 FDD	10	64QAM	0.59-0.66			≥ 2	
FDD	Table A.3.9.3-1	R.31E-3 FDD	20	64QAM	0.59-0.63			≥ 2	
FDD	Table A.3.9.1-1	R.31E-3C FDD	15	64QAM	0.87-0.92			≥ 3	
FDD	Table A.3.9.3-1	R.31E-3A FDD	10	64QAM	0.85-0.92			≥ 2	
FDD	Table A.3.9.3-1	R.31E-4 FDD	20	64QAM	0.87-0.91			≥ 3	

FDD	Table A.3.9.1-1	R.31E-4B FDD	15	64QAM	0.87-0.90			≥ 4	
TDD, EPDCCH scheduling									
TDD	Table A.3.9.4-1	R.31E-1 TDD	10	64QAM	0.40-0.41			≥ 1	
TDD	Table A.3.9.4-1	R.31E-2 TDD	10	64QAM	0.59-0.65			≥ 2	
TDD	Table A.3.9.4-1	R.31E-3 TDD	20	64QAM	0.59-0.63			≥ 2	
TDD	Table A.3.9.4-1	R.31E-3A TDD	15	64QAM	0.87-0.92			≥ 2	
TDD	Table A.3.9.4-1	R.31E-4 TDD	20	64QAM	0.87-0.90			≥ 3	

Table A.3.1.1-1Q: Overview of DL reference measurement channels (EPDCCH)

Duplex	Table	Name	BW	Mod	TCR	RB	RB Off set	UE Cat eg	Notes
FDD									
FDD	Table A.3.10.1-1	R.55 FDD	10	EPDCC H					
FDD	Table A.3.10.1-1	R.56 FDD	10	EPDCC H					
FDD	Table A.3.10.1-1	R.57 FDD	10	EPDCC H					
FDD	Table A.3.10.1-1	R.58 FDD	10	EPDCC H					
FDD	Table A.3.10.1-1	R.59 FDD	10	EPDCC H					
TDD									
TDD	Table A.3.10.2-1	R.55 TDD	10	EPDCC H					
TDD	Table A.3.10.2-1	R.56 TDD	10	EPDCC H					
TDD	Table A.3.10.2-1	R.57 TDD	10	EPDCC H					
TDD	Table A.3.10.2-1	R.58 TDD	10	EPDCC H					
TDD	Table A.3.10.2-1	R.59 TDD	10	EPDCC H					

A.3.2 Reference measurement channel for receiver characteristics

Tables A.3.2-1 and A.3.2-2 are applicable for measurements on the Receiver Characteristics (clause 7) with the exception of subclause 7.4 (Maximum input level).

Tables A.3.2-3, A.3.2-3a, A.3.2-3b, A.3.2-4, A.3.2-4a and A.3.2-4b are applicable for subclause 7.4 (Maximum input level).

Tables A.3.2-1 and A.3.2-2 also apply for the modulated interferer used in Clauses 7.5, 7.6 and 7.8 with test specific bandwidths.

Table A.3.2-1 Fixed Reference Channel for Receiver Requirements (FDD)

Parameter	Unit	Value					
		1.4	3	5	10	15	20
Channel bandwidth	MHz	1.4	3	5	10	15	20
Allocated resource blocks		6	15	25	50	75	100
Subcarriers per resource block		12	12	12	12	12	12
Allocated subframes per Radio Frame		9	9	9	9	9	9
Modulation		QPSK	QPSK	QPSK	QPSK	QPSK	QPSK
Target Coding Rate		1/3	1/3	1/3	1/3	1/3	1/3
Number of HARQ Processes	Processes	8	8	8	8	8	8
Maximum number of HARQ transmissions		1	1	1	1	1	1
Information Bit Payload per Sub-Frame							
For Sub-Frames 1,2,3,4,6,7,8,9	Bits	408	1320	2216	4392	6712	8760
For Sub-Frame 5	Bits	N/A	N/A	N/A	N/A	N/A	N/A
For Sub-Frame 0	Bits	152	872	1800	4392	6712	8760
Transport block CRC	Bits	24	24	24	24	24	24
Number of Code Blocks per Sub-Frame (Note 3)							
For Sub-Frames 1,2,3,4,6,7,8,9	Bits	1	1	1	1	2	2
For Sub-Frame 5	Bits	N/A	N/A	N/A	N/A	N/A	N/A
For Sub-Frame 0	Bits	1	1	1	1	2	2
Binary Channel Bits Per Sub-Frame							
For Sub-Frames 1,2,3,4,6,7,8,9	Bits	1368	3780	6300	13800	20700	27600
For Sub-Frame 5	Bits	N/A	N/A	N/A	N/A	N/A	N/A
For Sub-Frame 0	Bits	528	2940	5460	12960	19860	26760
Max. Throughput averaged over 1 frame	kbps	341.6	1143. 2	1952. 8	3952. 8	6040. 8	7884
UE Category		≥ 1	≥ 1	≥ 1	≥ 1	≥ 1	≥ 1
Note 1:	2 symbols allocated to PDCCH for 20 MHz, 15 MHz and 10MHz channel BW. 3 symbols allocated to PDCCH for 5 MHz and 3 MHz. 4 symbols allocated to PDCCH for 1.4 MHz						
Note 2:	Reference signal, Synchronization signals and PBCH allocated as per TS 36.211 [4]						
Note 3:	If more than one Code Block is present, an additional CRC sequence of L = 24 Bits is attached to each Code Block (otherwise L = 0 Bit)						

Table A.3.2-1a Fixed Reference Channel for Receiver Requirements (FDD)

Parameter	Unit	Value					
		1.4	3	5	10	15	20
Channel bandwidth	MHz	1.4	3	5	10	15	20
Allocated resource blocks		6	14	14	14	14	14
Subcarriers per resource block		12	12	12	12	12	12
Allocated subframes per Radio Frame		9	9	9	9	9	9
Modulation		QPSK	QPSK	QPSK	QPSK	QPSK	QPSK
Target Coding Rate		1/3	1/3	1/3	1/3	1/3	1/3
Number of HARQ Processes	Processes	8	8	8	8	8	8
Maximum number of HARQ transmissions		1	1	1	1	1	1
Information Bit Payload per Sub-Frame							
For Sub-Frames 1,2,3,4,6,7,8,9	Bits	408	1000	1000	1000	1000	1000
For Sub-Frame 5	Bits	N/A	N/A	N/A	N/A	N/A	N/A
For Sub-Frame 0 (Note 3)	Bits	152	840	840	904	904	904
Transport block CRC	Bits	24	24	24	24	24	24
Number of Code Blocks per Sub-Frame							
For Sub-Frames 1,2,3,4,6,7,8,9	Bits	1	1	1	1	1	1
For Sub-Frame 5	Bits	N/A	N/A	N/A	N/A	N/A	N/A
For Sub-Frame 0	Bits	1	1	1	1	1	1
Binary Channel Bits Per Sub-Frame							
For Sub-Frames 1,2,3,4,6,7,8,9	Bits	1368	3528	3528	3864	3864	3864
For Sub-Frame 5	Bits	N/A	N/A	N/A	N/A	N/A	N/A
For Sub-Frame 0 (Note 3)	Bits	528	2688	2688	3024	3024	3024
Max. Throughput averaged over 1 frame	kbps	341.6	884	884	890.4	890.4	890.4
UE DL Category		0	0	0	0	0	0
Note 1:	2 symbols allocated to PDCCH for 20 MHz, 15 MHz and 10MHz channel BW. 3 symbols allocated to PDCCH for 5 MHz and 3 MHz. 4 symbols allocated to PDCCH for 1.4 MHz						
Note 2:	Reference signal, Synchronization signals and PBCH allocated as per TS 36.211.						
Note 3:	For Sub-Frame 0, it is assumed the 6PRBs are allocated in the centre of the channel where some REs of the same PRBs are occupied by PBCH and synchronization signals.						
Note 4:	For HD-FDD UE, the downlink subframes are scheduled at the 0th, 1st, 2nd, 8th, 9th, 10th, 16th, 17th, 18th, 24th, 25th, 26th, 32nd, 33rd, 34th subframes every 40ms. Information bit payload is available if downlink subframe is scheduled.						

Table A.3.2-2 Fixed Reference Channel for Receiver Requirements (TDD)

Parameter	Unit	Value					
		1.4	3	5	10	15	20
Channel Bandwidth	MHz	1.4	3	5	10	15	20
Allocated resource blocks		6	15	25	50	75	100
Uplink-Downlink Configuration (Note 5)		1	1	1	1	1	1
Allocated subframes per Radio Frame (D+S)		3	3+2	3+2	3+2	3+2	3+2
Number of HARQ Processes	Processes	7	7	7	7	7	7
Maximum number of HARQ transmission		1	1	1	1	1	1
Modulation		QPSK	QPSK	QPSK	QPSK	QPSK	QPSK
Target coding rate		1/3	1/3	1/3	1/3	1/3	1/3
Information Bit Payload per Sub-Frame	Bits						
For Sub-Frame 4, 9		408	1320	2216	4392	6712	8760
For Sub-Frame 1, 6		N/A	968	1544	3240	4968	6712
For Sub-Frame 5		N/A	N/A	N/A	N/A	N/A	N/A
For Sub-Frame 0		208	1064	1800	4392	6712	8760
Transport block CRC	Bits	24	24	24	24	24	24
Number of Code Blocks per Sub-Frame (Note 4)							
For Sub-Frame 4, 9		1	1	1	1	2	2
For Sub-Frame 1, 6		N/A	1	1	1	1	2
For Sub-Frame 5		N/A	N/A	N/A	N/A	N/A	N/A
For Sub-Frame 0		1	1	1	1	2	2
Binary Channel Bits Per Sub-Frame	Bits						
For Sub-Frame 4, 9		1368	3780	6300	13800	20700	27600
For Sub-Frame 1, 6		N/A	3276	5556	11256	16956	22656
For Sub-Frame 5		N/A	N/A	N/A	N/A	N/A	N/A
For Sub-Frame 0		672	3084	5604	13104	20004	26904
Max. Throughput averaged over 1 frame	kbps	102.4	564	932	1965.6	3007.2	3970.4
UE Category		≥ 1	≥ 1	≥ 1	≥ 1	≥ 1	≥ 1
Note 1:	For normal subframes(0,4,5,9), 2 symbols allocated to PDCCH for 20 MHz, 15 MHz and 10 MHz channel BW; 3 symbols allocated to PDCCH for 5 MHz and 3 MHz; 4 symbols allocated to PDCCH for 1.4 MHz. For special subframe (1&6), only 2 OFDM symbols are allocated to PDCCH for all BWs.						
Note 2:	For 1.4MHz, no data shall be scheduled on special subframes(1&6) to avoid problems with insufficient PDCCH performance						
Note 3:	Reference signal, Synchronization signals and PBCH allocated as per TS 36.211 [4]						
Note 4:	If more than one Code Block is present, an additional CRC sequence of L = 24 Bits is attached to each Code Block (otherwise L = 0 Bit).						
Note 5:	As per Table 4.2-2 in TS 36.211 [4]						

Table A.3.2-2a Fixed Reference Channel for Receiver Requirements (TDD)

Parameter	Unit	Value					
		1.4	3	5	10	15	20
Channel Bandwidth	MHz	1.4	3	5	10	15	20
Allocated resource blocks		6	14	14	14	14	14
Uplink-Downlink Configuration (Note 5)		1	1	1	1	1	1
Allocated subframes per Radio Frame (D+S)		3	3+2	3+2	3+2	3+2	3+2
Number of HARQ Processes	Processes	7	7	7	7	7	7
Maximum number of HARQ transmission		1	1	1	1	1	1
Modulation		QPSK	QPSK	QPSK	QPSK	QPSK	QPSK
Target coding rate		1/3	1/3	1/3	1/3	1/3	1/3
Information Bit Payload per Sub-Frame	Bits						
For Sub-Frame 4, 9		408	1000	1000	1000	1000	1000
For Sub-Frame 1, 6		N/A	872	872	872	872	872
For Sub-Frame 5		N/A	N/A	N/A	N/A	N/A	N/A
For Sub-Frame 0		208	1000	1000	1000	1000	1000
Transport block CRC	Bits	24	24	24	24	24	24
Number of Code Blocks per Sub-Frame (Note 4)							
For Sub-Frame 4, 9		1	1	1	1	1	1
For Sub-Frame 1, 6		N/A	1	1	1	1	1
For Sub-Frame 5		N/A	N/A	N/A	N/A	N/A	N/A
For Sub-Frame 0		1	1	1	1	1	1
Binary Channel Bits Per Sub-Frame	Bits						
For Sub-Frame 4, 9		1368	3528	3528	3864	3864	3864
For Sub-Frame 1, 6		N/A	3048	3048	3048	3048	3048
For Sub-Frame 5		N/A	N/A	N/A	N/A	N/A	N/A
For Sub-Frame 0		672	2832	2832	3168	3168	3168
Max. Throughput averaged over 1 frame	kbps	102.4	474.4	474.4	474.4	474.4	474.4
UE DL Category		0	0	0	0	0	0
Note 1:	For normal subframes(0,4,5,9), 2 symbols allocated to PDCCH for 20 MHz, 15 MHz and 10 MHz channel BW; 3 symbols allocated to PDCCH for 5 MHz and 3 MHz; 4 symbols allocated to PDCCH for 1.4 MHz. For special subframe (1&6), only 2 OFDM symbols are allocated to PDCCH for all BWs.						
Note 2:	For 1.4MHz, no data shall be scheduled on special subframes(1&6) to avoid problems with insufficient PDCCH performance						
Note 3:	Reference signal, Synchronization signals and PBCH allocated as per TS 36.211 [4]						
Note 4:	If more than one Code Block is present, an additional CRC sequence of L = 24 Bits is attached to each Code Block (otherwise L = 0 Bit).						
Note 5:	As per Table 4.2-2 in TS 36.211 [4]						

Table A.3.2-3 Fixed Reference Channel for Maximum input level for UE Categories ≥ 3 (FDD)

Parameter	Unit	Value					
		1.4	3	5	10	15	20
Channel bandwidth	MHz	1.4	3	5	10	15	20
Allocated resource blocks		6	15	25	50	75	100
Subcarriers per resource block		12	12	12	12	12	12
Allocated subframes per Radio Frame		8	9	9	9	9	9
Modulation		64QAM	64QAM	64QAM	64QAM	64QAM	64QAM
Target Coding Rate		3/4	3/4	3/4	3/4	3/4	3/4
Number of HARQ Processes	Processes	8	8	8	8	8	8
Maximum number of HARQ transmissions		1	1	1	1	1	1
Information Bit Payload per Sub-Frame							
For Sub-Frames 1,2,3,4,6,7,8,9	Bits	2984	8504	14112	30576	46888	61664
For Sub-Frame 5	Bits	N/A	N/A	N/A	N/A	N/A	N/A
For Sub-Frame 0	Bits	N/A	6456	12576	28336	45352	61664
Transport block CRC	Bits	24	24	24	24	24	24
Number of Code Blocks per Sub-Frame (Note 3)							
For Sub-Frames 1,2,3,4,6,7,8,9		1	2	3	5	8	11
For Sub-Frame 5		N/A	N/A	N/A	N/A	N/A	N/A
For Sub-Frame 0		N/A	2	3	5	8	11
Binary Channel Bits Per Sub-Frame							
For Sub-Frames 1,2,3,4,6,7,8,9	Bits	4104	11340	18900	41400	62100	82800
For Sub-Frame 5	Bits	N/A	N/A	N/A	N/A	N/A	N/A
For Sub-Frame 0	Bits	N/A	8820	16380	38880	59580	80280
Max. Throughput averaged over 1 frame	kbps	2387.2	7448.8	12547	27294	42046	55498
Note 1:	2 symbols allocated to PDCCH for 20 MHz, 15 MHz and 10 MHz channel BW. 3 symbols allocated to PDCCH for 5 MHz and 3 MHz. 4 symbols allocated to PDCCH for 1.4 MHz.						
Note 2:	Reference signal, Synchronization signals and PBCH allocated as per TS 36.211 [4].						
Note 3:	If more than one Code Block is present, an additional CRC sequence of L = 24 Bits is attached to each Code Block (otherwise L = 0 Bit).						

Table A.3.2-3a Fixed Reference Channel for Maximum input level for UE Category 1 (FDD)

Parameter	Unit	Value					
		1.4	3	5	10	15	20
Channel bandwidth	MHz	1.4	3	5	10	15	20
Allocated resource blocks		6	15	18	17	17	17
Subcarriers per resource block		12	12	12	12	12	12
Allocated subframes per Radio Frame		8	9	9	9	9	9
Modulation		64QAM	64QAM	64QAM	64QAM	64QAM	64QAM
Target Coding Rate		3/4	3/4	3/4	3/4	3/4	3/4
Number of HARQ Processes	Processes	8	8	8	8	8	8
Maximum number of HARQ transmissions		1	1	1	1	1	1
Information Bit Payload							
For Sub-Frames 1,2,3,4,6,7,8,9	Bits	2984	8504	10296	10296	10296	10296
For Sub-Frame 5	Bits	N/A	N/A	N/A	N/A	N/A	N/A
For Sub-Frame 0	Bits	N/A	6456	8248	10296	10296	10296
Transport block CRC	Bits	24	24	24	24	24	24
Number of Code Blocks per Sub-Frame (Note 3)							
For Sub-Frames 1,2,3,4,6,7,8,9		1	2	2	2	2	2
For Sub-Frame 5		N/A	N/A	N/A	N/A	N/A	N/A
For Sub-Frame 0		N/A	2	2	2	2	2
Binary Channel Bits Per Sub-Frame							
For Sub-Frames 1,2,3,4,6,7,8,9	Bits	4104	11340	13608	14076	14076	14076
For Sub-Frame 5	Bits	N/A	N/A	N/A	N/A	N/A	N/A
For Sub-Frame 0	Bits	N/A	8820	11088	14076	14076	14076
Max. Throughput averaged over 1 frame	kbps	2387.2	7448.8	9079.6	9266.4	9266.4	9266.4
Note 1:	2 symbols allocated to PDCCH for 20 MHz, 15 MHz and 10 MHz channel BW. 3 symbols allocated to PDCCH for 5 MHz and 3 MHz. 4 symbols allocated to PDCCH for 1.4 MHz.						
Note 2:	Reference signal, Synchronization signals and PBCH allocated as per TS 36.211 [4].						
Note 3:	If more than one Code Block is present, an additional CRC sequence of L = 24 Bits is attached to each Code Block (otherwise L = 0 Bit).						

Table A.3.2-3b Fixed Reference Channel for Maximum input level for UE Category 2 (FDD)

Parameter	Unit	Value					
		1.4	3	5	10	15	20
Channel bandwidth	MHz	1.4	3	5	10	15	20
Allocated resource blocks		6	15	25	50	75	83
Subcarriers per resource block		12	12	12	12	12	12
Allocated subframes per Radio Frame		8	9	9	9	9	9
Modulation		64QAM	64QAM	64QAM	64QAM	64QAM	64QAM
Target Coding Rate		3/4	3/4	3/4	3/4	3/4	3/4
Number of HARQ Processes	Processes	8	8	8	8	8	8
Maximum number of HARQ transmissions		1	1	1	1	1	1
Information Bit Payload							
For Sub-Frames 1,2,3,4,6,7,8,9	Bits	2984	8504	14112	30576	46888	51024
For Sub-Frame 5	Bits	N/A	N/A	N/A	N/A	N/A	N/A
For Sub-Frame 0	Bits	N/A	6456	12576	28336	45352	51024
Transport block CRC	Bits	24	24	24	24	24	24
Number of Code Blocks per Sub-Frame (Note 3)							
For Sub-Frames 1,2,3,4,6,7,8,9		1	2	3	5	8	9
For Sub-Frame 5		N/A	N/A	N/A	N/A	N/A	N/A
For Sub-Frame 0		N/A	2	3	5	8	9
Binary Channel Bits Per Sub-Frame							
For Sub-Frames 1,2,3,4,6,7,8,9	Bits	4104	11340	18900	41400	62100	68724
For Sub-Frame 5	Bits	N/A	N/A	N/A	N/A	N/A	N/A
For Sub-Frame 0	Bits	N/A	8820	16380	38880	59580	66204
Max. Throughput averaged over 1 frame	kbps	2387.2	7448.8	12547	27294	42046	45922
Note 1:	2 symbols allocated to PDCCH for 20 MHz, 15 MHz and 10 MHz channel BW. 3 symbols allocated to PDCCH for 5 MHz and 3 MHz. 4 symbols allocated to PDCCH for 1.4 MHz.						
Note 2:	Reference signal, Synchronization signals and PBCH allocated as per TS 36.211 [4].						
Note 3:	If more than one Code Block is present, an additional CRC sequence of L = 24 Bits is attached to each Code Block (otherwise L = 0 Bit).						

Table A.3.2-3c Fixed Reference Channel for Maximum input level for UE DL Category 0 (FDD)

Parameter	Unit	Value					
		1.4	3	5	10	15	20
Channel bandwidth	MHz	1.4	3	5	10	15	20
Allocated resource blocks		2	2	2	2	2	2
Subcarriers per resource block		12	12	12	12	12	12
Allocated subframes per Radio Frame		8	9	9	9	9	9
Modulation		64QAM	64QAM	64QAM	64QAM	64QAM	64QAM
Target Coding Rate		3/4	3/4	3/4	3/4	3/4	3/4
Number of HARQ Processes	Processes	8	8	8	8	8	8
Maximum number of HARQ transmissions		1	1	1	1	1	1
Information Bit Payload							
For Sub-Frames 1,2,3,4,6,7,8,9	Bits	1000	1000	1000	1000	1000	1000
For Sub-Frame 5	Bits	N/A	N/A	N/A	N/A	N/A	N/A
For Sub-Frame 0 (Note 3)	Bits	N/A	1000	1000	1000	1000	1000
Transport block CRC	Bits	24	24	24	24	24	24
Number of Code Blocks per Sub-Frame							
For Sub-Frames 1,2,3,4,6,7,8,9		1	1	1	1	1	1
For Sub-Frame 5		N/A	N/A	N/A	N/A	N/A	N/A
For Sub-Frame 0		N/A	1	1	1	1	1
Binary Channel Bits Per Sub-Frame							
For Sub-Frames 1,2,3,4,6,7,8,9	Bits	1368	1512	1512	1656	1656	1656
For Sub-Frame 5	Bits	N/A	N/A	N/A	N/A	N/A	N/A
For Sub-Frame 0 (Note 3)	Bits	N/A	1512	1512	1656	1656	1656
Max. Throughput averaged over 1 frame	kbps	800	900	900	900	900	900
Note 1:	2 symbols allocated to PDCCH for 20 MHz, 15 MHz and 10 MHz channel BW. 3 symbols allocated to PDCCH for 5 MHz and 3 MHz. 4 symbols allocated to PDCCH for 1.4 MHz.						
Note 2:	Reference signal, Synchronization signals and PBCH allocated as per TS 36.211.						
Note 3:	For Sub-Frame 0, it is assumed that the allocated 2PRBs are scheduled on the RBs other than the center 6PRBs as most of the symbols are occupied by PBCH and synchronization signals.						

Table A.3.2-4 Fixed Reference Channel for Maximum input level for UE Categories ≥ 3 (TDD)

Parameter	Unit	Value					
		1.4	3	5	10	15	20
Channel bandwidth	MHz	1.4	3	5	10	15	20
Allocated resource blocks		6	15	25	50	75	100
Subcarriers per resource block		12	12	12	12	12	12
Uplink-Downlink Configuration (Note 5)		1	1	1	1	1	1
Allocated subframes per Radio Frame		2	3+2	3+2	3+2	3+2	3+2
Modulation		64QAM	64QAM	64QAM	64QAM	64QAM	64QAM
Target Coding Rate		3/4	3/4	3/4	3/4	3/4	3/4
Number of HARQ Processes	Processes	7	7	7	7	7	7
Maximum number of HARQ transmissions		1	1	1	1	1	1
Information Bit Payload per Sub-Frame							
For Sub-Frames 4,9	Bits	2984	8504	14112	30576	46888	61664
For Sub-Frames 1,6	Bits	N/A	6968	11448	23688	35160	46888
For Sub-Frame 5	Bits	N/A	N/A	N/A	N/A	N/A	N/A
For Sub-Frame 0	Bits	N/A	6968	12576	30576	45352	61664
Transport block CRC	Bits	24	24	24	24	24	24
Number of Code Blocks per Sub-Frame (Note 4)							
For Sub-Frames 4,9		1	2	3	5	8	11
For Sub-Frames 1,6		N/A	2	2	4	6	8
For Sub-Frame 5		N/A	N/A	N/A	N/A	N/A	N/A
For Sub-Frame 0		N/A	2	3	5	8	11
Binary Channel Bits per Sub-Frame							
For Sub-Frames 4,9	Bits	4104	11340	18900	41400	62100	82800
For Sub-Frames 1,6		N/A	9828	16668	33768	50868	67968
For Sub-Frame 5	Bits	N/A	N/A	N/A	N/A	N/A	N/A
For Sub-Frame 0	Bits	N/A	9252	16812	39312	60012	80712
Max. Throughput averaged over 1 frame	kbps	596.8	3791.2	6369.6	13910	20945	27877
Note 1:	For normal subframes(0,4,5,9), 2 symbols allocated to PDCCH for 20 MHz, 15 MHz and 10 MHz channel BW; 3 symbols allocated to PDCCH for 5 MHz and 3 MHz; 4 symbols allocated to PDCCH for 1.4 MHz. For special subframe (1&6), only 2 OFDM symbols are allocated to PDCCH for all BWs.						
Note 2:	For 1.4MHz, no data shall be scheduled on special subframes(1&6) to avoid problems with insufficient PDCCH performance.						
Note 3:	Reference signal, Synchronization signals and PBCH allocated as per TS 36.211 [4].						
Note 4:	If more than one Code Block is present, an additional CRC sequence of L = 24 Bits is attached to each Code Block (otherwise L = 0 Bit).						
Note 5:	As per Table 4.2-2 in TS 36.211 [4].						

Table A.3.2-4a Fixed Reference Channel for Maximum input level for UE Category 1 (TDD)

Parameter	Unit	Value					
		1.4	3	5	10	15	20
Channel bandwidth	MHz	1.4	3	5	10	15	20
Allocated resource blocks		6	15	18	17	17	17
Subcarriers per resource block		12	12	12	12	12	12
Uplink-Downlink Configuration (Note 5)		1	1	1	1	1	1
Allocated subframes per Radio Frame		2	3+2	3+2	3+2	3+2	3+2
Modulation		64QAM	64QAM	64QAM	64QAM	64QAM	64QAM
Target Coding Rate		3/4	3/4	3/4	3/4	3/4	3/4
Number of HARQ Processes	Processes	7	7	7	7	7	7
Maximum number of HARQ transmissions		1	1	1	1	1	1
Information Bit Payload per Sub-Frame							
For Sub-Frames 4,9	Bits	2984	8504	10296	10296	10296	10296
For Sub-Frames 1,6	Bits	N/A	6968	8248	7480	7480	7480
For Sub-Frame 5	Bits	N/A	N/A	N/A	N/A	N/A	N/A
For Sub-Frame 0	Bits	N/A	6968	8248	10296	10296	10296
Transport block CRC	Bits	24	24	24	24	24	24
Number of Code Blocks per Sub-Frame (Note 4)							
For Sub-Frames 4,9		1	2	2	2	2	2
For Sub-Frames 1,6		N/A	2	2	2	2	2
For Sub-Frame 5		N/A	N/A	N/A	N/A	N/A	N/A
For Sub-Frame 0		N/A	2	2	2	2	2
Binary Channel Bits per Sub-Frame							
For Sub-Frames 4,9	Bits	4104	11340	13608	14076	14076	14076
For Sub-Frames 1,6		N/A	9828	11880	11628	11628	11628
For Sub-Frame 5	Bits	N/A	N/A	N/A	N/A	N/A	N/A
For Sub-Frame 0	Bits	N/A	9252	11520	14076	14076	14076
Max. Throughput averaged over 1 frame	kbps	596.8	3791.2	4533.6	4584.8	4584.8	4584.8
Note 1:	For normal subframes(0,4,5,9), 2 symbols allocated to PDCCH for 20 MHz, 15 MHz and 10 MHz channel BW; 3 symbols allocated to PDCCH for 5 MHz and 3 MHz; 4 symbols allocated to PDCCH for 1.4 MHz. For special subframe (1&6), only 2 OFDM symbols are allocated to PDCCH for all BWs.						
Note 2:	For 1.4MHz, no data shall be scheduled on special subframes(1&6) to avoid problems with insufficient PDCCH performance.						
Note 3:	Reference signal, Synchronization signals and PBCH allocated as per TS 36.211 [4].						
Note 4:	If more than one Code Block is present, an additional CRC sequence of L = 24 Bits is attached to each Code Block (otherwise L = 0 Bit).						
Note 5:	As per Table 4.2-2 in TS 36.211 [4].						

Table A.3.2-4b Fixed Reference Channel for Maximum input level for UE Category 2 (TDD)

Parameter	Unit	Value					
		1.4	3	5	10	15	20
Channel bandwidth	MHz	1.4	3	5	10	15	20
Allocated resource blocks		6	15	25	50	75	83
Subcarriers per resource block		12	12	12	12	12	12
Uplink-Downlink Configuration (Note 5)		1	1	1	1	1	1
Allocated subframes per Radio Frame		2	3+2	3+2	3+2	3+2	3+2
Modulation		64QAM	64QAM	64QAM	64QAM	64QAM	64QAM
Target Coding Rate		3/4	3/4	3/4	3/4	3/4	3/4
Number of HARQ Processes	Processes	7	7	7	7	7	7
Maximum number of HARQ transmissions		1	1	1	1	1	1
Information Bit Payload per Sub-Frame							
For Sub-Frames 4,9	Bits	2984	8504	14112	30576	46888	51024
For Sub-Frames 1,6	Bits	N/A	6968	11448	23688	35160	39232
For Sub-Frame 5	Bits	N/A	N/A	N/A	N/A	N/A	N/A
For Sub-Frame 0	Bits	N/A	6968	12576	30576	45352	51024
Transport block CRC	Bits	24	24	24	24	24	24
Number of Code Blocks per Sub-Frame (Note 4)							
For Sub-Frames 4,9		1	2	3	5	8	9
For Sub-Frames 1,6		N/A	2	3	5	7	7
For Sub-Frame 5		N/A	N/A	N/A	N/A	N/A	N/A
For Sub-Frame 0		N/A	2	3	5	8	9
Binary Channel Bits per Sub-Frame							
For Sub-Frames 4,9	Bits	4104	11340	18900	41400	62100	68724
For Sub-Frames 1,6		N/A	9828	16668	33768	50868	56340
For Sub-Frame 5	Bits	N/A	N/A	N/A	N/A	N/A	N/A
For Sub-Frame 0	Bits	N/A	9252	16380	39312	60012	66636
Max. Throughput averaged over 1 frame	kbps	596.8	3791.2	6369.6	13910	20945	23154
Note 1:	For normal subframes(0,4,5,9), 2 symbols allocated to PDCCH for 20 MHz, 15 MHz and 10 MHz channel BW; 3 symbols allocated to PDCCH for 5 MHz and 3 MHz; 4 symbols allocated to PDCCH for 1.4 MHz. For special subframe (1&6), only 2 OFDM symbols are allocated to PDCCH for all BWs.						
Note 2:	For 1.4MHz, no data shall be scheduled on special subframes(1&6) to avoid problems with insufficient PDCCH performance.						
Note 3:	Reference signal, Synchronization signals and PBCH allocated as per TS 36.211 [4].						
Note 4:	If more than one Code Block is present, an additional CRC sequence of L = 24 Bits is attached to each Code Block (otherwise L = 0 Bit).						
Note 5:	As per Table 4.2-2 in TS 36.211 [4].						

Table A.3.2-4c Fixed Reference Channel for Maximum input level for UE DL Category 0 (TDD)

Parameter	Unit	Value					
		1.4	3	5	10	15	20
Channel bandwidth	MHz	1.4	3	5	10	15	20
Allocated resource blocks		2	2	2	2	2	2
Subcarriers per resource block		12	12	12	12	12	12
Uplink-Downlink Configuration (Note 5)		1	1	1	1	1	1
Allocated subframes per Radio Frame		2	3+2	3+2	3+2	3+2	3+2
Modulation		64QAM	64QAM	64QAM	64QAM	64QAM	64QAM
Target Coding Rate		3/4	3/4	3/4	3/4	3/4	3/4
Number of HARQ Processes	Processes	7	7	7	7	7	7
Maximum number of HARQ transmissions		1	1	1	1	1	1
Information Bit Payload per Sub-Frame							
For Sub-Frames 4,9	Bits	1000	1000	1000	1000	1000	1000
For Sub-Frames 1,6	Bits	N/A	712	712	712	712	712
For Sub-Frame 5	Bits	N/A	N/A	N/A	N/A	N/A	N/A
For Sub-Frame 0	Bits	N/A	1000	1000	1000	1000	1000
Transport block CRC	Bits	24	24	24	24	24	24
Number of Code Blocks per Sub-Frame (Note 4)							
For Sub-Frames 4,9		1	1	1	1	1	1
For Sub-Frames 1,6		N/A	1	1	1	1	1
For Sub-Frame 5		N/A	N/A	N/A	N/A	N/A	N/A
For Sub-Frame 0		N/A	1	1	1	1	1
Binary Channel Bits per Sub-Frame							
For Sub-Frames 4,9	Bits	1368	1512	1512	1656	1656	1656
For Sub-Frames 1,6		N/A	1224	1224	1368	1368	1368
For Sub-Frame 5	Bits	N/A	N/A	N/A	N/A	N/A	N/A
For Sub-Frame 0	Bits	N/A	1512	1512	1656	1656	1656
Max. Throughput averaged over 1 frame	kbps	200	442.4	442.4	442.4	442.4	442.4
Note 1:	For normal subframes(0,4,5,9), 2 symbols allocated to PDCCH for 20 MHz, 15 MHz and 10 MHz channel BW; 3 symbols allocated to PDCCH for 5 MHz and 3 MHz; 4 symbols allocated to PDCCH for 1.4 MHz. For special subframe (1&6), only 2 OFDM symbols are allocated to PDCCH for all BWs.						
Note 2:	For 1.4MHz, no data shall be scheduled on special subframes(1&6) to avoid problems with insufficient PDCCH performance.						
Note 3:	Reference signal, Synchronization signals and PBCH allocated as per TS 36.211 [4].						
Note 4:	If more than one Code Block is present, an additional CRC sequence of L = 24 Bits is attached to each Code Block (otherwise L = 0 Bit).						
Note 5:	As per Table 4.2-2 in TS 36.211 [4].						

Table A.3.2-5 Fixed Reference Channel for Maximum input level for UE Categories 11/12 and UE DL categories ≥ 11 (FDD)

Parameter	Unit	Value					
		1.4	3	5	10	15	20
Channel bandwidth	MHz	1.4	3	5	10	15	20
Allocated resource blocks		6	15	25	50	75	100
Subcarriers per resource block		12	12	12	12	12	12
Allocated subframes per Radio Frame		8	9	9	9	9	9
Modulation		256QAM	256QAM	256QAM	256QAM	256QAM	256QAM
Target Coding Rate		4/5	4/5	4/5	4/5	4/5	4/5
Number of HARQ Processes	Processes	8	8	8	8	8	8
Maximum number of HARQ transmissions		1	1	1	1	1	1
Information Bit Payload per Sub-Frame							
For Sub-Frames 1,2,3,4,6,7,8,9	Bits	4392	12216	19848	42368	63776	84760
For Sub-Frame 5	Bits	N/A	N/A	N/A	N/A	N/A	N/A
For Sub-Frame 0	Bits	N/A	9912	17568	40576	63776	84760
Transport block CRC	Bits	24	24	24	24	24	24
Number of Code Blocks per Sub-Frame (Note 3)							
For Sub-Frames 1,2,3,4,6,7,8,9		1	2	4	7	11	14
For Sub-Frame 5		N/A	N/A	N/A	N/A	N/A	N/A
For Sub-Frame 0		N/A	2	3	7	11	14
Binary Channel Bits Per Sub-Frame							
For Sub-Frames 1,2,3,4,6,7,8,9	Bits	5472	15120	25200	55200	82800	110400
For Sub-Frame 5	Bits	N/A	N/A	N/A	N/A	N/A	N/A
For Sub-Frame 0	Bits	N/A	12210	22290	51840	79440	107040
Max. Throughput averaged over 1 frame	kbps	3513.6	10764	17635.2	37952	57398.4	76284
Note 1:	2 symbols allocated to PDCCH for 20 MHz, 15 MHz and 10 MHz channel BW. 3 symbols allocated to PDCCH for 5 MHz and 3 MHz. 4 symbols allocated to PDCCH for 1.4 MHz.						
Note 2:	Reference signal, Synchronization signals and PBCH allocated as per TS 36.211 [4].						
Note 3:	If more than one Code Block is present, an additional CRC sequence of L = 24 Bits is attached to each Code Block (otherwise L = 0 Bit).						

Table A.3.2-6 Fixed Reference Channel for Maximum input level for UE Categories 11/12 and UE DL categories ≥ 11 (TDD)

Parameter	Unit	Value					
		1.4	3	5	10	15	20
Channel bandwidth	MHz	1.4	3	5	10	15	20
Allocated resource blocks		6	15	25	50	75	100
Subcarriers per resource block		12	12	12	12	12	12
Uplink-Downlink Configuration (Note 5)		1	1	1	1	1	1
Allocated subframes per Radio Frame		2	3+2	3+2	3+2	3+2	3+2
Modulation		256QAM	256QAM	256QAM	256QAM	256QAM	256QAM
Target Coding Rate		4/5	4/5	4/5	4/5	4/5	4/5
Number of HARQ Processes	Processes	7	7	7	7	7	7
Maximum number of HARQ transmissions		1	1	1	1	1	1
Information Bit Payload per Sub-Frame							
For Sub-Frames 4,9	Bits	4392	12216	19848	42368	63776	84760
For Sub-Frames 1,6	Bits	N/A	10680	17568	36696	55056	75376
For Sub-Frame 5	Bits	N/A	N/A	N/A	N/A	N/A	N/A
For Sub-Frame 0	Bits	N/A	9912	17568	42368	63776	84760
Transport block CRC	Bits	24	24	24	24	24	24
Number of Code Blocks per Sub-Frame (Note 4)							
For Sub-Frames 4,9		1	2	4	7	11	14
For Sub-Frames 1,6		N/A	2	3	6	9	13
For Sub-Frame 5		N/A	N/A	N/A	N/A	N/A	N/A
For Sub-Frame 0		N/A	2	3	7	11	14
Binary Channel Bits per Sub-Frame							
For Sub-Frames 4,9	Bits	5472	15120	25200	55200	82800	110400
For Sub-Frames 1,6		N/A	13104	22224	45024	67824	90624
For Sub-Frame 5	Bits	N/A	N/A	N/A	N/A	N/A	N/A
For Sub-Frame 0	Bits	N/A	12336	22416	52416	80016	107616
Max. Throughput averaged over 1 frame	kbps	878.4	5570.4	9240	20049.6	30144	40503.2
Note 1:	For normal subframes(0,4,5,9), 2 symbols allocated to PDCCH for 20 MHz, 15 MHz and 10 MHz channel BW; 3 symbols allocated to PDCCH for 5 MHz and 3 MHz; 4 symbols allocated to PDCCH for 1.4 MHz. For special subframe (1&6), only 2 OFDM symbols are allocated to PDCCH for all BWs.						
Note 2:	For 1.4MHz, no data shall be scheduled on special subframes(1&6) to avoid problems with insufficient PDCCH performance.						
Note 3:	Reference signal, Synchronization signals and PBCH allocated as per TS 36.211 [4].						
Note 4:	If more than one Code Block is present, an additional CRC sequence of L = 24 Bits is attached to each Code Block (otherwise L = 0 Bit).						
Note 5:	As per Table 4.2-2 in TS 36.211 [4].						

A.3.3 Reference measurement channels for PDSCH performance requirements (FDD)

A.3.3.1 Single-antenna transmission (Common Reference Symbols)

Table A.3.3.1-1: Fixed Reference Channel QPSK R=1/3

Parameter	Unit	Value					
		R.4 FDD	R.42 FDD	R.42-1 FDD	R.42-2 FDD	R.42-3 FDD	R.2 FDD
Reference channel							
Channel bandwidth	MHz	1.4	20	3	5	15	10
Allocated resource blocks (Note 4)		6	100	15	25	75	50
Allocated subframes per Radio Frame		9	9	9	9	9	9
Modulation		QPSK	QPSK	QPSK	QPSK	QPSK	QPSK
Target Coding Rate		1/3	1/3	1/3	1/3	1/3	1/3
Information Bit Payload (Note 4)							
For Sub-Frames 1,2,3,4,6,7,8,9	Bits	408	8760	1320	2216	6712	4392
For Sub-Frame 5	Bits	N/A	N/A	N/A	N/A	N/A	N/A
For Sub-Frame 0	Bits	152	8760	1064	1800	6712	4392
Number of Code Blocks (Notes 3 and 4)							
For Sub-Frames 1,2,3,4,6,7,8,9		1	2	1	1	2	1
For Sub-Frame 5		N/A	N/A	N/A	N/A	N/A	N/A
For Sub-Frame 0		1	2	1	1	2	1
Binary Channel Bits (Note 4)							
For Sub-Frames 1,2,3,4,6,7,8,9	Bits	1368	27600	3780	6300	20700	13800
For Sub-Frame 5	Bits	N/A	N/A	N/A	N/A	N/A	N/A
For Sub-Frame 0	Bits	528	26760	2940	5460	19860	12960
Max. Throughput averaged over 1 frame (Note 4)	Mbps	0.342	7.884	1.162	1.953	6.041	3.953
UE Category		≥ 1	≥ 1	≥ 1	≥ 1	≥ 1	≥ 1
Note 1:	2 symbols allocated to PDCCH for 20 MHz, 15 MHz and 10 MHz channel BW; 3 symbols allocated to PDCCH for 5 MHz and 3 MHz; 4 symbols allocated to PDCCH for 1.4 MHz.						
Note 2:	Reference signal, synchronization signals and PBCH allocated as per TS 36.211 [4].						
Note 3:	If more than one Code Block is present, an additional CRC sequence of L = 24 Bits is attached to each Code Block (otherwise L = 0 Bit).						
Note 4:	Given per component carrier per codeword.						

Table A.3.3.1-2: Fixed Reference Channel 16QAM R=1/2

Parameter	Unit	Value					
				R.3-1 FDD	R.3 FDD		
Reference channel							
Channel bandwidth	MHz	1.4	3	5	10	15	20
Allocated resource blocks				25	50		
Allocated subframes per Radio Frame				9	9		
Modulation				16QAM	16QAM		
Target Coding Rate				1/2	1/2		
Information Bit Payload							
For Sub-Frames 1,2,3,4,6,7,8,9	Bits			6456	14112		
For Sub-Frame 5	Bits			N/A	N/A		
For Sub-Frame 0	Bits			5736	12960		
Number of Code Blocks per Sub-Frame (Note 3)							
For Sub-Frames 1,2,3,4,6,7,8,9				2	3		
For Sub-Frame 5				N/A	N/A		
For Sub-Frame 0				1	3		
Binary Channel Bits Per Sub-Frame							
For Sub-Frames 1,2,3,4,6,7,8,9	Bits			12600	27600		
For Sub-Frame 5	Bits			N/A	N/A		
For Sub-Frame 0	Bits			10920	25920		
Max. Throughput averaged over 1 frame	Mbps			5.738	12.586		
UE Category				≥ 1	≥ 2		
Note 1: 2 symbols allocated to PDCCH for 20 MHz, 15 MHz and 10 MHz channel BW; 3 symbols allocated to PDCCH for 5 MHz and 3 MHz; 4 symbols allocated to PDCCH for 1.4 MHz. Note 2: Reference signal, synchronization signals and PBCH allocated as per TS 36.211 [4]. Note 3: If more than one Code Block is present, an additional CRC sequence of L = 24 Bits is attached to each Code Block (otherwise L = 0 Bit).							

Table A.3.3.1-3: Fixed Reference Channel 64QAM R=3/4

Parameter	Unit	Value					
			R.5 FDD	R.6 FDD	R.7 FDD	R.8 FDD	R.9 FDD
Reference channel							
Channel bandwidth	MHz	1.4	3	5	10	15	20
Allocated resource blocks			15	25	50	75	100
Allocated subframes per Radio Frame			9	9	9	9	9
Modulation		64QAM	64QAM	64QAM	64QAM	64QAM	64QAM
Target Coding Rate		3/4	3/4	3/4	3/4	3/4	3/4
Information Bit Payload							
For Sub-Frames 1,2,3,4,6,7,8,9	Bits		8504	14112	30576	46888	61664
For Sub-Frame 5	Bits		N/A	N/A	N/A	N/A	N/A
For Sub-Frame 0	Bits		6456	12576	28336	45352	61664
Number of Code Blocks per Sub-Frame (Note 3)							
For Sub-Frames 1,2,3,4,6,7,8,9			2	3	5	8	11
For Sub-Frame 5			N/A	N/A	N/A	N/A	N/A
For Sub-Frame 0			2	3	5	8	11
Binary Channel Bits Per Sub-Frame							
For Sub-Frames 1,2,3,4,6,7,8,9	Bits		11340	18900	41400	62100	82800
For Sub-Frame 5	Bits		N/A	N/A	N/A	N/A	N/A
For Sub-Frame 0	Bits		8820	16380	38880	59580	80280
Max. Throughput averaged over 1 frame	Mbps		7.449	12.547	27.294	42.046	55.498
UE Category			≥ 1	≥ 2	≥ 2	≥ 2	≥ 3
Note 1: 2 symbols allocated to PDCCH for 20 MHz, 15 MHz and 10 MHz channel BW; 3 symbols allocated to PDCCH for 5 MHz and 3 MHz; 4 symbols allocated to PDCCH for 1.4 MHz. Note 2: Reference signal, synchronization signals and PBCH allocated as per TS 36.211 [4]. Note 3: If more than one Code Block is present, an additional CRC sequence of L = 24 Bits is attached to each Code Block (otherwise L = 0 Bit).							

Table A.3.3.1-3a: Fixed Reference Channel 64QAM R=3/4

Parameter	Unit	Value				
		R.6-1 FDD	R.7-1 FDD	R.8-1 FDD	R.9-1 FDD	R.9-2 FDD
Reference channel						
Channel bandwidth	MHz	5	10	15	20	20
Allocated resource blocks (Note 3)		18	17	17	17	83
Allocated subframes per Radio Frame		9	9	9	9	9
Modulation		64QAM	64QAM	64QAM	64QAM	64QAM
Target Coding Rate		3/4	3/4	3/4	3/4	3/4
Information Bit Payload						
For Sub-Frames 1,2,3,4,6,7,8,9	Bits	10296	10296	10296	10296	51024
For Sub-Frame 5	Bits	N/A	N/A	N/A	N/A	N/A
For Sub-Frame 0	Bits	8248	10296	10296	10296	51024
Number of Code Blocks per Sub-Frame (Note 4)						
For Sub-Frames 1,2,3,4,6,7,8,9		2	2	2	2	9
For Sub-Frame 5		N/A	N/A	N/A	N/A	N/A
For Sub-Frame 0		2	2	2	2	9
Binary Channel Bits Per Sub-Frame						
For Sub-Frames 1,2,3,4,6,7,8,9	Bits	13608	14076	14076	14076	68724
For Sub-Frame 5	Bits	N/A	N/A	N/A	N/A	N/A
For Sub-Frame 0	Bits	11088	14076	14076	14076	66204
Max. Throughput averaged over 1 frame	Mbps	9.062	9.266	9.266	9.266	45.922
UE Category		≥ 1	≥ 1	≥ 1	≥ 1	≥ 2
Note 1:	2 symbols allocated to PDCCH for 20 MHz, 15 MHz and 10 MHz channel BW; 3 symbols allocated to PDCCH for 5 MHz and 3 MHz; 4 symbols allocated to PDCCH for 1.4 MHz.					
Note 2:	Reference signal, synchronization signals and PBCH allocated as per TS 36.211 [4].					
Note 3:	Localized allocation started from RB #0 is applied.					
Note 4:	If more than one Code Block is present, an additional CRC sequence of L = 24 Bits is attached to each Code Block (otherwise L = 0 Bit).					

Table A.3.3.1-4: Fixed Reference Channel Single PRB (Channel Edge)

Parameter	Unit	Value					
		R.0 FDD		R.1 FDD			
Reference channel							
Channel bandwidth	MHz	1.4	3	5	10/20	15	20
Allocated resource blocks			1		1		
Allocated subframes per Radio Frame			9		9		
Modulation			16QAM		16QAM		
Target Coding Rate			1/2		1/2		
Information Bit Payload							
For Sub-Frames 1,2,3,4,6,7,8,9	Bits		224		256		
For Sub-Frame 5	Bits		N/A		N/A		
For Sub-Frame 0	Bits		224		256		
Number of Code Blocks per Sub-Frame (Note 3)							
For Sub-Frames 1,2,3,4,6,7,8,9			1		1		
For Sub-Frame 5			N/A		N/A		
For Sub-Frame 0			1		1		
Binary Channel Bits Per Sub-Frame							
For Sub-Frames 1,2,3,4,6,7,8,9	Bits		504		552		
For Sub-Frame 5	Bits		N/A		N/A		
For Sub-Frame 0	Bits		504		552		
Max. Throughput averaged over 1 frame	Mbps		0.202		0.230		
UE Category			≥ 1		≥ 1		
Note 1:	2 symbols allocated to PDCCH for 20 MHz, 15 MHz and 10 MHz channel BW; 3 symbols allocated to PDCCH for 5 MHz and 3 MHz; 4 symbols allocated to PDCCH for 1.4 MHz.						
Note 2:	Reference signal, synchronization signals and PBCH allocated as per TS 36.211 [4].						
Note 3:	If more than one Code Block is present, an additional CRC sequence of L = 24 Bits is attached to each Code Block (otherwise L = 0 Bit).						

Table A.3.3.1-5: Fixed Reference Channel Single PRB (MBSFN Configuration)

Parameter	Unit	Value
Reference channel		R.29 FDD (MBSFN)
Channel bandwidth	MHz	10
Allocated resource blocks		1
MBSFN Configuration (Note 4)		111111
Allocated subframes per Radio Frame		3
Modulation		16QAM
Target Coding Rate		1/2
Information Bit Payload		
For Sub-Frames 4,9	Bits	256
For Sub-Frame 5	Bits	N/A
For Sub-Frame 0	Bits	256
For Sub-Frame 1,2,3,6,7,8	Bits	0 (MBSFN)
Number of Code Blocks per Sub-Frame (Note 3)		
For Sub-Frames 4,9		1
For Sub-Frame 5		N/A
For Sub-Frame 0		1
For Sub-Frame 1,2,3,6,7,8		0 (MBSFN)
Binary Channel Bits Per Sub-Frame		
For Sub-Frames 4,9	Bits	552
For Sub-Frame 5	Bits	N/A
For Sub-Frame 0	Bits	552
For Sub-Frame 1,2,3,6,7,8	Bits	0 (MBSFN)
Max. Throughput averaged over 1 frame	kbps	76.8
UE Category		≥ 1
Note 1:	2 symbols allocated to PDCCH.	
Note 2:	Reference signal, synchronization signals and PBCH allocated as per TS 36.211 [4].	
Note 3:	If more than one Code Block is present, an additional CRC sequence of L = 24 Bits is attached to each Code Block (otherwise L = 0 Bit).	
Note 4:	MBSFN Subframe Allocation as defined in [7], one frame with 6 bits is chosen for MBSFN subframe allocation	

Table A.3.3.1-6: Fixed Reference Channel QPSK R=1/10

Parameter	Unit	Value					
					R.41 FDD		
Reference channel							
Channel bandwidth	MHz	1.4	3	5	10	15	20
Allocated resource blocks					50		
Allocated subframes per Radio Frame					9		
Modulation					QPSK		
Target Coding Rate					1/10		
Information Bit Payload							
For Sub-Frames 1,2,3,4,6,7,8,9	Bits				1384		
For Sub-Frame 5	Bits				N/A		
For Sub-Frame 0	Bits				1384		
Number of Code Blocks per Sub-Frame (Note 3)							
For Sub-Frames 1,2,3,4,6,7,8,9					1		
For Sub-Frame 5					N/A		
For Sub-Frame 0					1		
Binary Channel Bits Per Sub-Frame							
For Sub-Frames 1,2,3,4,6,7,8,9	Bits				13800		
For Sub-Frame 5	Bits				N/A		
For Sub-Frame 0	Bits				12960		
Max. Throughput averaged over 1 frame	Mbps				1.246		
UE Category					≥ 1		
<p>Note 1: 2 symbols allocated to PDCCH for 20 MHz, 15 MHz and 10 MHz channel BW; 3 symbols allocated to PDCCH for 5 MHz and 3 MHz; 4 symbols allocated to PDCCH for 1.4 MHz.</p> <p>Note 2: Reference signal, synchronization signals and PBCH allocated as per TS 36.211 [4].</p> <p>Note 3: If more than one Code Block is present, an additional CRC sequence of L = 24 Bits is attached to each Code Block (otherwise L = 0 Bit).</p>							

Table A.3.3.1-7: Fixed Reference Channel for CA demodulation with power imbalance

Parameter	Unit	Value		
		R.49 FDD	R.49-1 FDD	R.49-2 FDD
Reference channel				
Channel bandwidth	MHz	20	10	5
Allocated resource blocks		100	50	25
Allocated subframes per Radio Frame		9	9	9
Modulation		64QAM	64QAM	64QAM
Coding Rate				
For Sub-Frame 1,2,3,4,6,7,8,9,		0.84	0.84	0.84
For Sub-Frame 5		N/A	N/A	N/A
For Sub-Frame 0		0.87	0.87	0.86
Information Bit Payload				
For Sub-Frames 1,2,3,4,6,7,8,9	Bits	63776	31704	15840
For Sub-Frame 5	Bits	N/A	N/A	N/A
For Sub-Frame 0		63776	30576	14112
Number of Code Blocks per Sub-Frame (Note 3)				
For Sub-Frames 0,1,2,3,4,6,7,8,9	Code Blocks	11	6	3
For Sub-Frame 5	Code Blocks	N/A	N/A	N/A
Binary Channel Bits Per Sub-Frame			5	3
For Sub-Frames 1,2,3,4,6,7,8,9	Bits	75600		
For Sub-Frame 5	Bits	N/A	37800	18900
For Sub-Frame 0	Bits	73080	N/A	N/A
Max. Throughput averaged over 1 frame	Mbps	57.398	35280	16380
UE Category		≥5	≥2	≥2
<p>Note 1: 3 symbols allocated to PDCCH.</p> <p>Note 2: Reference signal, synchronization signals and PBCH allocated as per TS 36.211 [4].</p> <p>Note 3: If more than one Code Block is present, an additional CRC sequence of L = 24 Bits is attached to each Code Block (otherwise L = 0 Bit).</p>				

A.3.3.2 Multi-antenna transmission (Common Reference Symbols)

A.3.3.2.1 Two antenna ports

Table A.3.3.2.1-1: Fixed Reference Channel two antenna ports

Parameter	Unit	Value											
		R.10 FDD	R.11 FDD	R.11-1 FDD	R.11-2 FDD	R.11-3 FDD Note 5	R.11-4 FDD	R.30 FDD	R.30-1 FDD	R.35-1 FDD	R.35 FDD	R.35-2 FDD	R.35-3 FDD
Reference channel													
Channel bandwidth	MHz	10	10	10	5	10	10	20	15	20	10	15	10
Allocated resource blocks (Note 4)		50	50	50	25	40	50	100	75	100	50	75	50
Allocated subframes per Radio Frame		9	9	8	9	9	9	9	8	8	9	8	8
Modulation		QPSK	16QA M	16QA M	16QA M	16QA M	QPSK	16QA M	16QA M	64QA M	64QA M	64QA M	64QA M
Target Coding Rate		1/3	1/2	1/2	1/2	1/2	1/2	1/2	1/2	0.39	1/2	0.39	0.39
Information Bit Payload (Note 4)													
For Sub-Frames 1,2,3,4,6,7,8,9	Bits	4392	12960	12960	5736	10296	6968	25456	19080	30576	19848	22920	15264
For Sub-Frame 5	Bits	N/A	N/A	N/A	N/A	N/A	N/A	N/A	N/A	N/A	N/A	N/A	N/A
For Sub-Frame 0	Bits	4392	12960	N/A	4968	10296	6968	25456	N/A	N/A	18336	N/A	N/A
Number of Code Blocks (Notes 3 and 4)													
For Sub-Frames 1,2,3,4,6,7,8,9	Bits	1	3	3	1	2	2	5	4	5	4	4	3
For Sub-Frame 5	Bits	N/A	N/A	N/A	N/A	N/A	N/A	N/A	N/A	N/A	N/A	N/A	N/A
For Sub-Frame 0	Bits	1	3	N/A	1	2	2	5	N/A	N/A	3	N/A	N/A
Binary Channel Bits (Note 4)													
For Sub-Frames 1,2,3,4,6,7,8,9	Bits	13200	26400	26400	12000	21120	13200	52800	39600	79200	39600	59400	39600
For Sub-Frame 5	Bits	N/A	N/A	N/A	N/A	N/A	N/A	N/A	N/A	N/A	N/A	N/A	N/A
For Sub-Frame 0	Bits	12384	24768	N/A	10368	19488	12384	51168	N/A	N/A	37152	N/A	N/A
Max. Throughput averaged over 1 frame (Note 4)	Mbps	3.953	11.664	10.368	5.086	9.266	6.271	22.910	15.264	24.461	17.712	18.336	12.211
UE Category		≥ 1	≥ 2	≥ 2	≥ 1	≥ 1	≥ 1	≥ 2	≥ 2	4	≥ 2	≥ 2	≥ 2
Note 1:	2 symbols allocated to PDCCH for 20 MHz, 15 MHz and 10 MHz channel BW; 3 symbols allocated to PDCCH for 5 MHz and 3 MHz; 4 symbols allocated to PDCCH for 1.4 MHz.												
Note 2:	Reference signal, synchronization signals and PBCH allocated as per TS 36.211 [4].												
Note 3:	If more than one Code Block is present, an additional CRC sequence of L = 24 Bits is attached to each Code Block (otherwise L = 0 Bit).												
Note 4:	Given per component carrier per codeword.												
Note 5:	For R.11-3 resource blocks of RB6–RB45 are allocated.												

Table A.3.3.2.1-2: Fixed Reference Channel two antenna ports

Parameter	Unit	Value									
		R.46 FDD	R.47 FDD	R.35-4 FDD	R.11-5 FDD	R.11-6 FDD	R.11-7 FDD	R.11-8 FDD	R.11-9 FDD	R.11-10 FDD	R.65 FDD
Reference channel											
Channel bandwidth	MHz	10	10	10	1.4	3	15	10	10	10	10
Allocated resource blocks (Note 4)		50	50	50	6	15	75	50	50	50	50
Number of subframes per Radio Frame		9	9	9	8	9	9	9	8	8	9
Number of PDCCH symbols		2	2	2	4	3	2	2	3	3	2
Modulation		QPSK	16QAM	64QAM	16QAM	16QAM	16QAM	QPSK	QPSK	QPSK	256QAM
Target Coding Rate				0.47	1/2	1/2	1/2	3/5	0.58	0.67	0.55
Information Bit Payload (Note 4)											
For Frames 1,2,3,4,6,7,8,9	Bits	5160	8760	18336	1352	3368	19080	7992	6968	7992	31704
For Frame 5	Bits	N/A	N/A	N/A	N/A	N/A	N/A	N/A	N/A	N/A	N/A
For Frame 0	Bits	5160	8760	16416	N/A	2664	19080	6968	N/A	N/A	N/A
Number of Code Blocks (Note 4)											
For Frames 1,2,3,4,6,7,8,9	Bits	1	2	3	1	1	4	2	2	2	6
For Frame 5	Bits	N/A	N/A	N/A	N/A	N/A	N/A	N/A	N/A	N/A	N/A
For Frame 0	Bits	1	2	3	1	1	4	2	N/A	N/A	N/A
Channel Bits (Note 4)											
For Frames 1,2,3,4,6,7,8,9	Bits	13200	26400	39600	2592	7200	39600	13200	12000	12000	57600
For Frame 5	Bits	N/A	N/A	N/A	N/A	N/A	N/A	N/A	N/A	N/A	N/A
For Frame 0	Bits	12384	24768	37152	N/A	5568	37968	12384	N/A	N/A	N/A
Throughput averaged over 1 subframe (Note 4)	Mbps	4.644	7.884	16.310	1.082	2.961	17.172	7.0904	5.5744	6.3936	25.363
UE Category		≥ 1	≥ 1	≥ 2	≥ 1	≥ 1	≥ 2	≥ 2	≥ 1	≥ 1	11-12
UE Category		≥ 6	≥ 6	≥ 6	≥ 6	≥ 6	≥ 6	≥ 6			≥ 11

Void

Reference signal, synchronization signals and PBCH allocated as per TS 36.211 [4]

If more than one Code Block is present, an additional CRC sequence of L = 24 Bits is attached to each Code Block (otherwise L = 0 Bit)

Given per component carrier per codeword.

Table A.3.3.2.1-3: Fixed Reference Channel two antenna ports

Parameter	Unit	Value	
		R.62 FDD	R.63 FDD
Reference channel			
Channel bandwidth	MHz	10	10
Allocated resource blocks (Note 4)		3	1
Allocated DL subframes per 4 Radio Frames (Note 3)		15	15
Modulation		16QAM	64QAM
Target Coding Rate		1/2	1/2
Information Bit Payload			
For Sub-Frames 0,1,2,3,4,5,6,7,8,9	Bits	744	408
Number of Code Blocks			
For Sub-Frames 0,1,2,3,4,5,6,7,8,9	Code blocks	1	1
Binary Channel Bits			
For Sub-Frames 0,1,2,3,4,5,6,7,8,9	Bits	1584	792
Max. Throughput averaged over 4 frames	Mbps	0.279	0.153
UE DL Category		0	0
Note 1:	2 symbols allocated to PDCCH		
Note 2:	Reference signal, synchronization signals and PBCH allocated as per TS 36.211 [4]		
Note 3:	The downlink subframes are scheduled at the 0th, 1st, 2nd, 8th, 9th, 10th, 16th, 17th, 18th, 24th, 25th, 26th, 32nd, 33rd, 34th subframes every 40ms. Information bit payload is available if downlink subframe is scheduled.		
Note 4:	Allocated PRB positions start from {9, 10, ..., 9+N-1}, where N is the number of allocated resource blocks.		

A.3.3.2.2 Four antenna ports

Table A.3.3.2.2-1: Fixed Reference Channel four antenna ports

Parameter	Unit	Value										
		R.12 FDD	R.13 FDD	R.14 FDD	R.14-1 FDD	R.14-2 FDD	R.14-3 FDD	R.36 FDD	R.14-4 FDD	R.14-5 FDD	R.14-6 FDD	R.14-7 FDD
Reference channel												
Channel bandwidth	MHz	1.4	10	10	10	10	20	10	1.4	3	5	15
Allocated resource blocks (Note 4)		6	50	50	6	3	100	50	6	15	25	75
Allocated subframes per Radio Frame		9	9	9	8	8	9	9	8	9	9	9
Modulation		QPS K	QPS K	16Q AM	16QA M	16QA M	16QA M	64Q AM	16QA M	16QA M	16QA M	16QA M
Target Coding Rate		1/3	1/3	1/2	1/2	1/2	1/2	1/2	1/2	1/2	1/2	1/2
Information Bit Payload (Note 4)												
For Sub-Frames 1,2,3,4,6,7,8,9	Bits	408	4392	12960	1544	744	25456	18336	1192	3368	5736	19080
For Sub-Frame 5	Bits	N/A	N/A	N/A	N/A	N/A	n/a	N/A	N/A	N/A	N/A	N/A
For Sub-Frame 0	Bits	152	3624	11448	N/A	N/A	22920	18336	N/A	2664	4968	19080
Number of Code Blocks (Notes 3 and 4)												
For Sub-Frames 1,2,3,4,6,7,8,9		1	1	3	1	1	5	3	1	1	1	4
For Sub-Frame 5		N/A	N/A	N/A	N/A	N/A	n/a	N/A	N/A	N/A	N/A	N/A
For Sub-Frame 0		1	1	2	N/A	N/A	4	3	N/A	1	1	4
Binary Channel Bits (Note 4)												
For Sub-Frames 1,2,3,4,6,7,8,9	Bits	1248	12800	25600	3072	1536	51200	38400	2496	6960	11600	38400
For Sub-Frame 5	Bits	N/A	N/A	N/A	N/A	N/A	n/a	N/A	N/A	N/A	N/A	N/A
For Sub-Frame 0	Bits	480	12032	24064	N/A	N/A	49664	36096	N/A	5424	10064	36864
Max. Throughput averaged over 1 frame (Note 4)	Mbps	0.342	3.876	11.513	1.235	0.595	22.656	16.502	0.954	2.961	5.086	17.172
UE Category		≥ 1	≥ 1	≥ 2	≥ 1	≥ 1	≥ 2	≥ 2	≥ 1	≥ 1	≥ 1	≥ 2
Note 1:	2 symbols allocated to PDCCH for 20 MHz, 15 MHz and 10 MHz channel BW; 3 symbols allocated to PDCCH for 5 MHz and 3 MHz; 4 symbols allocated to PDCCH for 1.4 MHz.											
Note 2:	Reference signal, synchronization signals and PBCH allocated as per TS 36.211 [4].											
Note 3:	If more than one Code Block is present, an additional CRC sequence of L = 24 Bits is attached to each Code Block (otherwise L = 0 Bit).											
Note 4:	Given per component carrier per codeword.											

A.3.3.3 Reference Measurement Channel for UE-Specific Reference Symbols

A.3.3.3.0 Two antenna ports (no CSI-RS)

The reference measurement channels in Table A.3.3.3.0-1 apply with two CRS antenna ports and without CSI-RS.

Table A.3.3.3.0-1: Fixed Reference Channel without CSI-RS

Parameter	Unit	Value	
Reference channel		R.70 FDD	R.71 FDD
Channel bandwidth	MHz	10	10
Allocated resource blocks		50	50
Allocated subframes per Radio Frame		10	10
Modulation		QPSK	16QAM
Target Coding Rate		0.65	0.6
Information Bit Payload			
For Sub-Frames 1,2,3,4,6,7,8,9	Bits	6968	12960
For Sub-Frame 5	Bits	N/A	N/A
For Sub-Frame 0	Bits	N/A	N/A
Number of Code Blocks per Sub-Frame (Note 4)			
For Sub-Frames 1,2,3,4,6,7,8,9		2	3
For Sub-Frame 5		N/A	N/A
For Sub-Frame 0		N/A	N/A
Binary Channel Bits Per Sub-Frame			
For Sub-Frames 1,2,3,4,6,7,8,9	Bits	10800	21600
For Sub-Frame 5	Bits	N/A	N/A
For Sub-Frame 0	Bits	N/A	N/A
Max. Throughput averaged over 1 frame	Mbps	5.5744	10.368
UE Category		≥ 1	≥ 2
Note 1: 3 symbols allocated to PDCCH.			
Note 2: Reference signal, synchronization signals and PBCH allocated as per TS 36.211 [4]			
Note 3: If more than one Code Block is present, an additional CRC sequence of L = 24 Bits is attached to each Code Block (otherwise L = 0 Bit)			

A.3.3.3.1 Two antenna port (CSI-RS)

The reference measurement channels in Table A.3.3.3.1-1 apply for verifying demodulation performance for UE-specific reference symbols with two cell-specific antenna ports and two CSI-RS antenna ports.

Table A.3.3.3.1-1: Fixed Reference Channel for CDM-multiplexed DM RS with two CSI-RS antenna ports

Parameter	Unit	Value
Reference channel		R.51 FDD
Channel bandwidth	MHz	10
Allocated resource blocks		50 (Note 3)
Allocated subframes per Radio Frame		9
Modulation		16QAM
Target Coding Rate		1/2
Information Bit Payload		
For Sub-Frames 1,4,6,9	Bits	11448
For Sub-Frames 2,3,7,8	Bits	11448
For Sub-Frame 5	Bits	N/A
For Sub-Frame 0	Bits	9528
Number of Code Blocks (Note 4)		
For Sub-Frames 1,4,6,9	Code blocks	2
For Sub-Frames 2,3,7,8	Code blocks	2
For Sub-Frame 5	Bits	N/A
For Sub-Frame 0	Bits	2
Binary Channel Bits		
For Sub-Frames 1,4,6,9	Bits	24000
For Sub-Frames 2,7		23600
For Sub-Frames 3,8		23200
For Sub-Frame 5	Bits	N/A
For Sub-Frame 0	Bits	19680
Max. Throughput averaged over 1 frame	Mbps	10.1112
UE Category		≥ 2
Note 1:	2 symbols allocated to PDCCH.	
Note 2:	Reference signal, synchronization signals and PBCH allocated as per TS 36.211 [4].	
Note 3:	50 resource blocks are allocated in sub-frames 1, 2, 3, 4, 6, 7, 8, 9 and 41 resource blocks (RB0–RB20 and RB30–RB49) are allocated in sub-frame 0.	
Note 4:	If more than one Code Block is present, an additional CRC sequence of L = 24 Bits is attached to each Code Block (otherwise L = 0 Bit).	

The reference measurement channels in Table A3.3.3.1-2 apply for verifying demodulation performance for UE-specific reference symbols with two cell specific antenna ports and two CSI-RS antenna ports with ZP CSI-RS and NZP CSI-RS in same subframe.

Table A.3.3.3.1-2: Fixed Reference Channel for CDM-multiplexed DM RS with two CSI-RS antenna ports with ZP CSI-RS and NZP CSI-RS

Parameter	Unit	Value		
		R.52 FDD	R.53 FDD	R.54 FDD
Reference channel		R.52 FDD	R.53 FDD	R.54 FDD
Channel bandwidth	MHz	10	10	10
Allocated resource blocks		50 (Note 3)	50 (Note 3)	50 (Note 3)
Allocated subframes per Radio Frame		9	9	9
Modulation		64QAM	64QAM	16QAM
Target Coding Rate		1/2	1/2	1/2
Information Bit Payload				
For Sub-Frames 1,3,4,6,8,9	Bits	18336	18336	11448
For Sub-Frames 2,7	Bits	16416	16416	11448
For Sub-Frame 5	Bits	n/a	n/a	n/a
For Sub-Frame 0	Bits	14688	14688	9528
Number of Code Blocks (Note 4)				
For Sub-Frames 1,3,4,6,8,9	Code blocks	3	3	2
For Sub-Frames 2, 7	Code blocks	3	3	2
For Sub-Frame 5	Bits	n/a	n/a	n/a
For Sub-Frame 0	Bits	3	3	2
Binary Channel Bits				
For Sub-Frames 1,3,4,6,8,9	Bits	36000	36000	24000
For Sub-Frames 2,7		34200	33600	22800
For Sub-Frame 5	Bits	n/a	n/a	n/a
For Sub-Frame 0	Bits	29520	29520	19680
Max. Throughput averaged over 1 frame	Mbps	15.7536	15.7536	10.1112
Note 1: 2 symbols allocated to PDCCH.				
Note 2: Reference signal, synchronization signals and PBCH allocated as per TS 36.211 [4].				
Note 3: 50 resource blocks are allocated in sub-frames 1, 2, 3, 4, 6, 7, 8, 9 and 41 resource blocks (RB0–RB20 and RB30–RB49) are allocated in sub-frame 0.				
Note 4: If more than one Code Block is present, an additional CRC sequence of L = 24 Bits is attached to each Code Block (otherwise L = 0 Bit).				

A.3.3.3.2 Four antenna ports (CSI-RS)

The reference measurement channels in Table A.3.3.3.2-1 apply for verifying demodulation performance for UE-specific reference symbols with two cell-specific antenna ports and four CSI-RS antenna ports.

Table A.3.3.3.2-1: Fixed Reference Channel for CDM-multiplexed DM RS with four CSI-RS antenna ports

Parameter	Unit	Value			
		R.43 FDD	R.50 FDD	R.48 FDD	R.66 FDD
Reference channel		R.43 FDD	R.50 FDD	R.48 FDD	R.66 FDD
Channel bandwidth	MHz	10	10	10	10
Allocated resource blocks		50 (Note 3)	50 (Note 3)	50 (Note 3)	50 (Note 3)
Allocated subframes per Radio Frame		9	9	9	9
Modulation		QPSK	64QAM	QPSK	256QAM
Target Coding Rate		1/3	1/2		0.77
Information Bit Payload					
For Sub-Frames 1,4,6,9	Bits	3624	18336	6200	36696
For Sub-Frames 2,3,7,8	Bits	3624	16416	6200	35160
For Sub-Frame 5	Bits	N/A	N/A	N/A	N/A
For Sub-Frame 0	Bits	2984	14688	4968	30576
Number of Code Blocks (Note 4)					
For Sub-Frames 1,4,6,9	Code blocks	1	3	2	6
For Sub-Frames 2,3,7,8	Code blocks	1	3	2	6
For Sub-Frame 5	Bits	N/A	N/A	N/A	N/A
For Sub-Frame 0	Bits	1	3	1	5
Binary Channel Bits					
For Sub-Frames 1,4,6,9	Bits	12000	36000	12000	48000
For Sub-Frames 2,7		11600	34800	11600	46400
For Sub-Frames 3,8		11600	34800	12000	46400
For Sub-Frame 5	Bits	N/A	N/A	N/A	N/A
For Sub-Frame 0	Bits	9840	29520	9840	39360
Max. Throughput averaged over 1 frame	Mbps	3.1976	15.3696	5.4568	31.800
UE Category		≥ 1	≥ 2	≥ 1	11-12
UE DL Category		≥ 6	≥ 6	≥ 6	≥ 11
Note 1:	2 symbols allocated to PDCCH.				
Note 2:	Reference signal, synchronization signals and PBCH allocated as per TS 36.211 [4].				
Note 3:	50 resource blocks are allocated in sub-frames 1, 2, 3, 4, 6, 7, 8, 9 and 41 resource blocks (RB0–RB20 and RB30–RB49) are allocated in sub-frame 0.				
Note 4:	If more than one Code Block is present, an additional CRC sequence of L = 24 Bits is attached to each Code Block (otherwise L = 0 Bit).				

The reference measurement channels in Table A.3.3.3.2-2 apply for verifying FDD PMI accuracy measurement with two CRS antenna ports and four CSI-RS antenna ports.

Table A.3.3.3.2-2: Fixed Reference Channel for four antenna ports (CSI-RS)

Parameter	Unit	Value			
		R.44 FDD	R.45 FDD	R.45-1 FDD	R.60 FDD
Reference channel					
Channel bandwidth	MHz	10	10	10	10
Allocated resource blocks		50 ³	50 ³	39	50 ³
Allocated subframes per Radio Frame		10	10	10	10
Modulation		QPSK	16QAM	16QAM	QPSK
Target Coding Rate		1/3	1/2	1/2	1/2
Information Bit Payload					
For Sub-Frames (Non CSI-RS subframe)	Bits	3624	11448	8760	6200
For Sub-Frames (CSI-RS subframe)	Bits	3624	11448	8760	6200
For Sub-Frames (ZeroPowerCSI-RS subframe)	Bits	N/A	N/A	N/A	N/A
For Sub-Frame 5	Bits	N/A	N/A	N/A	N/A
For Sub-Frame 0	Bits	2984	9528	8760	N/A
Number of Code Blocks per Sub-Frame (Note 4)					
For Sub-Frames (Non CSI-RS subframe)		1	2	2	2
For Sub-Frames (CSI-RS subframe)		1	2	2	2
For Sub-Frames (ZeroPowerCSI-RS subframe)	Bits	N/A	N/A	N/A	N/A
For Sub-Frame 5		N/A	N/A	N/A	N/A
For Sub-Frame 0		1	2	2	N/A
Binary Channel Bits Per Sub-Frame					
For Sub-Frames (Non CSI-RS subframe)	Bits	12000	24000	18720	12000
For Sub-Frames (CSI-RS subframe)	Bits	11600	23200	18096	11600
For Sub-Frames (ZeroPowerCSI-RS subframe)	Bits	N/A	N/A	N/A	N/A
For Sub-Frame 5	Bits	N/A	N/A	N/A	N/A
For Sub-Frame 0	Bits	9840	19680	18720	N/A
Max. Throughput averaged over 1 frame	Mbps	3.1976	10.1112	7.884	4.96
UE Category		≥ 1	≥ 2	≥ 1	≥ 1
Note 1:	2 symbols allocated to PDCCH for 20 MHz, 15 MHz and 10 MHz channel BW; 3 symbols allocated to PDCCH for 5 MHz and 3 MHz; 4 symbols allocated to PDCCH for 1.4 MHz				
Note 2:	Reference signal, synchronization signals and PBCH allocated as per TS 36.211 [4]				
Note 3:	For R.44, R.45 and R.60, 50 resource blocks are allocated in sub-frames 1,2,3,4,6,7,8,9 and 41 resource blocks (RB0–RB20 and RB30–RB49) are allocated in sub-frame 0. For R.45-1, 39 resource blocks are allocated in all subframes (RB0–RB20 and RB30–RB47).				
Note 4:	If more than one Code Block is present, an additional CRC sequence of L = 24 Bits is attached to each Code Block (otherwise L = 0 Bit)				

The reference measurement channels in Table A.3.3.3.2-3 apply for verifying demodulation performance for UE-specific reference symbols with two cell-specific antenna ports and four CSI-RS antenna ports.

Table A.3.3.3.2-3: Fixed Reference Channel for CDM-multiplexed DM RS with four CSI-RS antenna ports

Parameter	Unit	Value
Reference channel		R.64 FDD
Channel bandwidth	MHz	10
Allocated resource blocks (Note 4)		6
Allocated subframes per 4 Radio Frames		15
Modulation		QPSK
Target Coding Rate		1/3
Information Bit Payload		
For Sub-Frames 0,1,4,5,6,9 (Note 3)	Bits	504
For Sub-Frames 2,3,7,8 (Note 3)	Bits	504
Number of Code Blocks		
For Sub-Frames 0,1,4,5,6,9	Code blocks	1
For Sub-Frames 2,3,7,8	Code blocks	1
Binary Channel Bits		
For Sub-Frames 0,1,4,5,6,9	Bits	1440
For Sub-Frames 2,3,7,8	Bits	1392
Max. Throughput averaged over 4 frames	Mbps	0.189
UE DL Category		0
Note 1:	2 symbols allocated to PDCCH.	
Note 2:	Reference signal, synchronization signals and PBCH allocated as per TS 36.211 [4].	
Note 3:	The downlink subframes are scheduled at the 0th, 1st, 2nd, 8th, 9th, 10th, 16th, 17th, 18th, 24th, 25th, 26th, 32nd, 33rd, 34th subframes every 40ms. Information bit payload is available if downlink subframe is scheduled.	
Note 4:	Allocated PRB positions start from {9, 10, ..., 9+N-1}, where N is the number of allocated resource blocks.	

The reference measurement channels in Table A.3.3.3.2-4 apply with two CRS antenna ports and four CSI-RS antenna ports.

Table A.3.3.3.2-4: Fixed Reference Channel for four antenna ports (CSI-RS)

Parameter	Unit	Value
Reference channel		R.69 FDD
Channel bandwidth	MHz	10
Allocated resource blocks		50
Allocated subframes per Radio Frame		8
Modulation		QPSK
Target Coding Rate		
For Sub-Frames 2,3,4,6,7,8,9		0.74
For Sub-Frame 1		0.8
Information Bit Payload		
For Sub-Frames 2,3,4,6,7,8,9	Bits	7992
For Sub-Frame 1	Bits	7992
For Sub-Frame 5	Bits	N/A
For Sub-Frame 0	Bits	N/A
Number of Code Blocks per Sub-Frame (Note 4)		
For Sub-Frames 2,3,4,6,7,8,9		2
For Sub-Frame 1		2
For Sub-Frame 5		N/A
For Sub-Frame 0		N/A
Binary Channel Bits Per Sub-Frame		
For Sub-Frames 2,3,4,6,7,8,9	Bits	10800
For Sub-Frame 1	Bits	10000
2 For Sub-Frame 5	Bits	N/A
For Sub-Frame 0	Bits	N/A
Max. Throughput averaged over 1 frame	Mbps	6.3936
UE Category		≥ 1
Note 1: 3 symbols allocated to PDCCH.		
Note 2: Reference signal, synchronization signals and PBCH allocated as per TS 36.211 [4]		
Note 3: If more than one Code Block is present, an additional CRC sequence of L = 24 Bits is attached to each Code Block (otherwise L = 0 Bit)		

A.3.4 Reference measurement channels for PDSCH performance requirements (TDD)

A.3.4.1 Single-antenna transmission (Common Reference Symbols)

Table A.3.4.1-1: Fixed Reference Channel QPSK R=1/3

Parameter	Unit	Value						
		R.4 TDD	R.42 TDD	R.2A TDD	R.2 TDD	R.42-1 TDD	R.42-2 TDD	R.42-3 TDD
Reference channel		R.4 TDD	R.42 TDD	R.2A TDD	R.2 TDD	R.42-1 TDD	R.42-2 TDD	R.42-3 TDD
Channel bandwidth	MHz	1.4	20	10	10	3	5	15
Allocated resource blocks (Note 6)		6	100	50	50	15	25	75
Uplink-Downlink Configuration (Note 4)		1	1	2	1	1	1	1
Allocated subframes per Radio Frame (D+S)		3	3+2	5+2	3+2	3+2	3+2	3+2
Modulation		QPSK	QPSK	QPSK	QPSK	QPSK	QPSK	QPSK
Target Coding Rate		1/3	1/3	1/3	1/3	1/3	1/3	1/3
Information Bit Payload (Note 6)								
For Sub-Frames 4,9	Bits	408	8760	4392	4392	1320	2216	6712
For Sub-Frames 1,6	Bits	N/A	7736	3240	3240	1128	1864	5992
For Sub-Frames 3,8	Bits	N/A	N/A	4392	N/A	N/A	N/A	N/A
For Sub-Frame 5	Bits	N/A	N/A	N/A	N/A	N/A	N/A	N/A
For Sub-Frame 0	Bits	208	8760	4392	4392	1064	1800	6712
Number of Code Blocks (Notes 5 and 6)								
For Sub-Frames 4,9		1	2	1	1	1	1	2
For Sub-Frames 1,6		N/A	2	1	1	1	1	1
For Sub-Frames 3,8		N/A	N/A	1	N/A	N/A	N/A	N/A
For Sub-Frame 5		N/A	N/A	N/A	N/A	N/A	N/A	N/A
For Sub-Frame 0		1	2	1	1	1	1	2
Binary Channel Bits (Note 6)								
For Sub-Frames 4,9	Bits	1368	27600	13800	13800	3780	6300	20700
For Sub-Frames 1,6	Bits	N/A	22656	11256	11256	3276	5556	16956
For Sub-Frames 3,8		N/A	N/A	13800	N/A	N/A	N/A	N/A
For Sub-Frame 5	Bits	N/A	N/A	N/A	N/A	N/A	N/A	N/A
For Sub-Frame 0	Bits	672	26904	13104	13104	3084	5604	20004
Max. Throughput averaged over 1 frame (Note 6)	Mbps	0.102	4.175	2.844	1.966	0.596	0.996	3.212
UE Category		≥ 1	≥ 1	≥ 1	≥ 1	≥ 1	≥ 1	≥ 1
Note 1:	2 symbols allocated to PDCCH for 20 MHz, 15 MHz and 10 MHz channel BW; 3 symbols allocated to PDCCH for 5 MHz and 3 MHz; 4 symbols allocated to PDCCH for 1.4 MHz. For subframe 1&6, only 2 OFDM symbols are allocated to PDCCH.							
Note 2:	For BW=1.4 MHz, the information bit payloads of special subframes are set to zero (no scheduling) to avoid problems with insufficient PDCCH performance at the test point.							
Note 3:	Reference signal, synchronization signals and PBCH allocated as per TS 36.211 [4].							
Note 4:	As per Table 4.2-2 in TS 36.211 [4].							
Note 5:	If more than one Code Block is present, an additional CRC sequence of L = 24 Bits is attached to each Code Block (otherwise L = 0 Bit).							
Note 6:	Given per component carrier per codeword.							

Table A.3.4.1-2: Fixed Reference Channel 16QAM R=1/2

Parameter	Unit	Value					
				R.3-1 TDD	R.3 TDD		
Reference channel							
Channel bandwidth	MHz	1.4	3	5	10	15	20
Allocated resource blocks				25	50		
Uplink-Downlink Configuration (Note 3)				1	1		
Allocated subframes per Radio Frame (D+S)				3+2	3+2		
Modulation				16QAM	16QAM		
Target Coding Rate				1/2	1/2		
Information Bit Payload							
For Sub-Frames 4,9	Bits			6456	14112		
For Sub-Frames 1,6	Bits			5160	11448		
For Sub-Frame 5	Bits			N/A	N/A		
For Sub-Frame 0	Bits			5736	12960		
Number of Code Blocks per Sub-Frame (Note 4)							
For Sub-Frames 4,9				2	3		
For Sub-Frames 1,6				1	2		
For Sub-Frame 5				N/A	N/A		
For Sub-Frame 0				1	3		
Binary Channel Bits Per Sub-Frame							
For Sub-Frames 4,9	Bits			12600	27600		
For Sub-Frames 1,6	Bits			11112	22512		
For Sub-Frame 5	Bits			N/A	N/A		
For Sub-Frame 0	Bits			11208	26208		
Max. Throughput averaged over 1 frame	Mbps			2.897	6.408		
UE Category				≥ 1	≥ 2		
Note 1:	2 symbols allocated to PDCCH for 20 MHz, 15 MHz and 10 MHz channel BW; 3 symbols allocated to PDCCH for 5 MHz and 3 MHz; 4 symbols allocated to PDCCH for 1.4 MHz. For subframe 1&6, only 2 OFDM symbols are allocated to PDCCH.						
Note 2:	Reference signal, synchronization signals and PBCH allocated as per TS 36.211 [4]						
Note 3:	As per Table 4.2-2 in TS 36.211 [4].						
Note 4:	If more than one Code Block is present, an additional CRC sequence of L = 24 Bits is attached to each Code Block (otherwise L = 0 Bit).						

Table A.3.4.1-3: Fixed Reference Channel 64QAM R=3/4

Parameter	Unit	Value					
			R.5 TDD	R.6 TDD	R.7 TDD	R.8 TDD	R.9 TDD
Reference channel							
Channel bandwidth	MHz	1.4	3	5	10	15	20
Allocated resource blocks			15	25	50	75	100
Uplink-Downlink Configuration (Note 3)			1	1	1	1	1
Allocated subframes per Radio Frame (D+S)			3+2	3+2	3+2	3+2	3+2
Modulation		64QAM	64QAM	64QAM	64QAM	64QAM	64QAM
Target Coding Rate			3/4	3/4	3/4	3/4	3/4
Information Bit Payload							
For Sub-Frames 4,9	Bits		8504	14112	30576	46888	61664
For Sub-Frames 1,6	Bits		6968	11448	23688	35160	46888
For Sub-Frame 5	Bits		N/A	N/A	N/A	N/A	N/A
For Sub-Frame 0	Bits		6968	12576	30576	45352	61664
Number of Code Blocks per Sub-Frame (Note 4)							
For Sub-Frames 4,9			2	3	5	8	11
For Sub-Frames 1,6			2	2	4	6	8
For Sub-Frame 5			N/A	N/A	N/A	N/A	N/A
For Sub-Frame 0			2	3	5	8	11
Binary Channel Bits Per Sub-Frame							
For Sub-Frames 4,9	Bits		11340	18900	41400	62100	82800
For Sub-Frames 1,6	Bits		9828	16668	33768	50868	67968
For Sub-Frame 5	Bits		N/A	N/A	N/A	N/A	N/A
For Sub-Frame 0	Bits		9252	16812	39312	60012	80712
Max. Throughput averaged over 1 frame	Mbps		3.791	6.370	13.910	20.945	27.877
UE Category			≥ 1	≥ 2	≥ 2	≥ 2	≥ 3
Note 1:	2 symbols allocated to PDCCH for 20 MHz, 15 MHz and 10 MHz channel BW; 3 symbols allocated to PDCCH for 5 MHz and 3 MHz; 4 symbols allocated to PDCCH for 1.4 MHz. For subframe 1&6, only 2 OFDM symbols are allocated to PDCCH.						
Note 2:	Reference signal, synchronization signals and PBCH allocated as per TS 36.211 [4]						
Note 3:	As per Table 4.2-2 TS 36.211 [4].						
Note 4:	If more than one Code Block is present, an additional CRC sequence of L = 24 Bits is attached to each Code Block (otherwise L = 0 Bit).						

Table A.3.4.1-3a: Fixed Reference Channel 64QAM R=3/4

Parameter	Unit	Value				
		R.6-1 TDD	R.7-1 TDD	R.8-1 TDD	R.9-1 TDD	R.9-2 TDD
Reference channel						
Channel bandwidth	MHz	5	10	15	20	20
Allocated resource blocks (Note 3)		18	17	17	17	83
Uplink-Downlink Configuration (Note 4)		1	1	1	1	1
Allocated subframes per Radio Frame (D+S)		3+2	3+2	3+2	3+2	3+2
Modulation		64QAM	64QAM	64QAM	64QAM	64QAM
Target Coding Rate		3/4	3/4	3/4	3/4	3/4
Information Bit Payload						
For Sub-Frames 4,9	Bits	10296	10296	10296	10296	51024
For Sub-Frames 1,6	Bits	8248	7480	7480	7480	39232
For Sub-Frame 5	Bits	N/A	N/A	N/A	N/A	N/A
For Sub-Frame 0	Bits	8248	10296	10296	10296	51024
Number of Code Blocks per Sub-Frame (Note 5)						
For Sub-Frames 4,9		2	2	2	2	9
For Sub-Frames 1,6		2	2	2	2	7
For Sub-Frame 5		N/A	N/A	N/A	N/A	N/A
For Sub-Frame 0		2	2	2	2	9
Binary Channel Bits Per Sub-Frame						
For Sub-Frames 4,9	Bits	13608	14076	14076	14076	68724
For Sub-Frames 1,6	Bits	11880	11628	11628	11628	56340
For Sub-Frame 5	Bits	N/A	N/A	N/A	N/A	N/A
For Sub-Frame 0	Bits	11520	14076	14076	14076	66636
Max. Throughput averaged over 1 frame	Mbps	4.534	4.585	4.585	4.585	23.154
UE Category		≥ 1	≥ 1	≥ 1	≥ 1	≥ 2
Note 1:	2 symbols allocated to PDCCH for 20 MHz, 15 MHz and 10 MHz channel BW; 3 symbols allocated to PDCCH for 5 MHz and 3 MHz; 4 symbols allocated to PDCCH for 1.4 MHz. For subframe 1&6, only 2 OFDM symbols are allocated to PDCCH.					
Note 2:	Reference signal, synchronization signals and PBCH allocated as per TS 36.211 [4]					
Note 3:	Localized allocation started from RB #0 is applied.					
Note 4:	As per Table 4.2-2 TS 36.211 [4].					
Note 5:	If more than one Code Block is present, an additional CRC sequence of L = 24 Bits is attached to each Code Block (otherwise L = 0 Bit).					

Table A.3.4.1-4: Fixed Reference Channel Single PRB

Parameter	Unit	Value					
			R.0 TDD		R.1 TDD		
Reference channel							
Channel bandwidth	MHz	1.4	3	5	10/20	15	20
Allocated resource blocks			1		1		
Uplink-Downlink Configuration (Note 3)			1		1		
Allocated subframes per Radio Frame (D+S)			3+2		3+2		
Modulation			16QAM		16QAM		
Target Coding Rate			1/2		1/2		
Information Bit Payload							
For Sub-Frames 4,9	Bits		224		256		
For Sub-Frames 1,6	Bits		208		208		
For Sub-Frame 5	Bits		N/A		N/A		
For Sub-Frame 0	Bits		224		256		
Number of Code Blocks per Sub-Frame (Note 4)							
For Sub-Frames 4,9			1		1		
For Sub-Frames 1,6			1		1		
For Sub-Frame 5			N/A		N/A		
For Sub-Frame 0			1		1		
Binary Channel Bits Per Sub-Frame							
For Sub-Frames 4,9	Bits		504		552		
For Sub-Frames 1,6	Bits		456		456		
For Sub-Frame 5	Bits		N/A		N/A		
For Sub-Frame 0	Bits		504		552		
Max. Throughput averaged over 1 frame	Mbps		0.109		0.118		
UE Category			≥ 1		≥ 1		
Note 1:	2 symbols allocated to PDCCH for 20 MHz, 15 MHz and 10 MHz channel BW; 3 symbols allocated to PDCCH for 5 MHz and 3 MHz; 4 symbols allocated to PDCCH for 1.4 MHz. For subframe 1&6, only 2 OFDM symbols are allocated to PDCCH.						
Note 2:	Reference signal, synchronization signals and PBCH allocated as per TS 36.211 [4]						
Note 3:	As per Table 4.2-2 in TS 36.211 [4].						
Note 4:	If more than one Code Block is present, an additional CRC sequence of L = 24 Bits is attached to each Code Block (otherwise L = 0 Bit).						

Table A.3.4.1-5: Fixed Reference Channel Single PRB (MBSFN Configuration)

Parameter	Unit	Value
Reference channel		R.29 TDD (MBSFN)
Channel bandwidth	MHz	10
Allocated resource blocks		1
MBSFN Configuration (Note 5)		010010
Uplink-Downlink Configuration (Note 3)		1
Allocated subframes per Radio Frame (D+S)		1+2
Modulation		16QAM
Target Coding Rate		1/2
Information Bit Payload		
For Sub-Frames 4,9	Bits	0 (MBSFN)
For Sub-Frames 1,6	Bits	208
For Sub-Frame 5	Bits	N/A
For Sub-Frame 0	Bits	256
Number of Code Blocks per Sub-Frame (Note 4)		
For Sub-Frames 4,9	Bits	0 (MBSFN)
For Sub-Frames 1,6	Bits	1
For Sub-Frame 5	Bits	N/A
For Sub-Frame 0	Bits	1
Binary Channel Bits Per Sub-Frame		
For Sub-Frames 4,9	Bits	0 (MBSFN)
For Sub-Frames 1,6	Bits	456
For Sub-Frame 5	Bits	N/A
For Sub-Frame 0	Bits	552
Max. Throughput averaged over 1 frame	kbps	67.2
UE Category		≥ 1
Note 1:	2 symbols allocated to PDCCH.	
Note 2:	Reference signal, synchronization signals and PBCH allocated as per TS 36.211 [4].	
Note 3:	as per Table 4.2-2 in TS 36.211 [4].	
Note 4:	If more than one Code Block is present, an additional CRC sequence of L = 24 Bits is attached to each Code Block (otherwise L = 0 Bit).	
Note 5:	MBSFN Subframe Allocation as defined in [7], one frame with 6 bits is chosen for MBSFN subframe allocation	

Table A.3.4.1-6: Fixed Reference Channel QPSK R=1/10

Parameter	Unit	Value					
					R.41 TDD		
Reference channel							
Channel bandwidth	MHz	1.4	3	5	10	15	20
Allocated resource blocks					50		
Uplink-Downlink Configuration (Note 4)					1		
Allocated subframes per Radio Frame (D+S)					3+2		
Modulation					QPSK		
Target Coding Rate					1/10		
Information Bit Payload							
For Sub-Frames 4,9	Bits				1384		
For Sub-Frames 1,6	Bits				1032		
For Sub-Frame 5	Bits				N/A		
For Sub-Frame 0	Bits				1384		
Number of Code Blocks per Sub-Frame (Note 5)							
For Sub-Frames 4,9					1		
For Sub-Frames 1,6					1		
For Sub-Frame 5					N/A		
For Sub-Frame 0					1		
Binary Channel Bits Per Sub-Frame							
For Sub-Frames 4,9	Bits				13800		
For Sub-Frames 1,6	Bits				11256		
For Sub-Frame 5	Bits				N/A		
For Sub-Frame 0	Bits				13104		
Max. Throughput averaged over 1 frame	Mbps				0.622		
UE Category					≥ 1		
Note 1:	2 symbols allocated to PDCCH for 20 MHz, 15 MHz and 10 MHz channel BW; 3 symbols allocated to PDCCH for 5 MHz and 3 MHz; 4 symbols allocated to PDCCH for 1.4 MHz. For subframe 1&6, only 2 OFDM symbols are allocated to PDCCH.						
Note 2:	For BW=1.4 MHz, the information bit payloads of special subframes are set to zero (no scheduling) to avoid problems with insufficient PDCCH performance at the test point.						
Note 3:	Reference signal, synchronization signals and PBCH allocated as per TS 36.211 [4]						
Note 4:	As per Table 4.2-2 in TS 36.211 [4].						
Note 5:	If more than one Code Block is present, an additional CRC sequence of L = 24 Bits is attached to each Code Block (otherwise L = 0 Bit).						

Table A.3.4.1-7: Fixed Reference Channel for CA demodulation with power imbalance

Parameter	Unit	Value	
		R.49 TDD	R.49-1 TDD
Reference channel		R.49 TDD	R.49-1 TDD
Channel bandwidth	MHz	20	15
Allocated resource blocks		100	75
Uplink-Downlink Configuration (Note 1)		1	1
Allocated subframes per Radio Frame (D+S)		3+2	3+2
Modulation		64QAM	64QAM
Number of OFDM symbols for PDCCH per component carrier			
For Sub-Frames 0,4,5,9	OFDM symbols	3	3
For Sub-Frames 1,6	OFDM symbols	2	2
Target Coding Rate			
For Sub-Frames 4,9		0.84	0.83
For Sub-Frames 1,6		0.81	0.80
For Sub-Frames 5		N/A	N/A
For Sub-Frames 0		0.87	0.86
Information Bit Payload			
For Sub-Frames 0, 4, 9	Bits	63776	46888
For Sub-Frame 1,6	Bits	55056	40576
For Sub-Frame 5	Bits	N/A	N/A
Number of Code Blocks per Sub-Frame (Note 2)			
For Sub-Frames 0, 4, 9	Code Blocks	11	8
For Sub-Frame 1,6	Code Blocks	9	7
For Sub-Frame 5	Code Blocks	N/A	N/A
Binary Channel Bits Per Sub-Frame			
For Sub-Frames 4,9	Bits	75600	56700
For Sub-Frame 1,6	Bits	67968	50868
For Sub-Frame 5	Bits	N/A	N/A
For Sub-Frame 0	Bits	73512	54612
Max. Throughput averaged over 1 frame	Mbps	30.144	22.182
UE Category		≥5	≥3
Note 1: Reference signal, synchronization signals and PBC allocated as per TS 36.211 [4].			
Note 2: If more than one Code Block is present, an additional CRC sequence of L = 24 Bits is attached to each Code Block (otherwise L = 0 Bit).			

A.3.4.2 Multi-antenna transmission (Common Reference Signals)

A.3.4.2.1 Two antenna ports

Table A.3.4.2.1-1: Fixed Reference Channel two antenna ports

Parameter	Unit						Value			
		R.10 TDD	R.11 TDD	R.11-1 TDD	R.11-2 TDD	R.11-3 TDD Note 6	R.11-4 TDD	R.30 TDD	R.30-1 TDD	R.30-2 TDD
Reference channel										
Channel bandwidth	MHz	10	10	10	5	10	10	20	20	20
Allocated resource blocks (Note 5)		50	50	50	25	40	50	100	100	100
Uplink-Downlink Configuration (Note 3)		1	1	1	1	1	1	1	1	1
Allocated subframes per Radio Frame (D+S)		3+2	3+2	2+2	3+2	3+2	2	3+2	2+2	2
Modulation		QPSK	16QAM	16QAM	16QAM	16QAM	QPSK	16QAM	16QAM	16QAM
Target Coding Rate		1/3	1/2	1/2	1/2	1/2	1/2	1/2	1/2	1/2
Information Bit Payload (Note 5)										
For Sub-Frames 4,9	Bits	4392	12960	12960	5736	10296	6968	25456	25456	25456
For Sub-Frames 1,6		3240	9528	9528	5160	9144	N/A	22920	21384	N/A
For Sub-Frame 5	Bits	N/A	N/A	N/A	N/A	N/A	N/A	N/A	N/A	N/A
For Sub-Frame 0	Bits	4392	12960	N/A	4968	10296	N/A	25456	N/A	N/A
Number of Code Blocks (Notes 4 and 5)										
For Sub-Frames 4,9		1	3	3	1	2	2	5	5	5
For Sub-Frames 1,6		1	2	2	1	2	N/A	4	4	N/A
For Sub-Frame 5		N/A	N/A	N/A	N/A	N/A	N/A	N/A	N/A	N/A
For Sub-Frame 0		1	3	N/A	1	2	N/A	5	N/A	N/A
Binary Channel Bits (Note 5)										
For Sub-Frames 4,9	Bits	13200	26400	26400	12000	21120	13200	52800	52800	52800
For Sub-Frames 1,6		10656	21312	21312	10512	16992	10656	42912	42912	N/A
For Sub-Frame 5	Bits	N/A	N/A	N/A	N/A	N/A	N/A	N/A	N/A	N/A
For Sub-Frame 0	Bits	12528	25056	N/A	10656	19776	12528	51456	N/A	N/A
Max. Throughput averaged over 1 frame (Note 5)	Mbps	1.966	5.794	4.498	2.676	4.918	1.39	12.221	9.368	5.091
UE Category		≥ 1	≥ 2	≥ 2	≥ 1	≥ 1	≥ 1	≥ 2	≥ 2	3
Note 1:	2 symbols allocated to PDCCH for 20 MHz, 15 MHz and 10 MHz channel BW; 3 symbols allocated to PDCCH for 5 MHz; 4 symbols allocated to PDCCH for 1.4 MHz. For subframe 1&6, only 2 OFDM symbols are allocated to PDCCH.									
Note 2:	Reference signal, synchronization signals and PBCH allocated as per TS 36.211 [4].									
Note 3:	As per Table 4.2-2 in TS 36.211 [4].									
Note 4:	If more than one Code Block is present, an additional CRC sequence of L = 24 Bits is attached to each Code Block (other than the first).									
Note 5:	Given per component carrier per codeword.									
Note 6:	For R.11-3 resource blocks of RB6–RB45 are allocated.									

Table A.3.4.2.1-2: Fixed Reference Channel two antenna ports

Parameter	Unit	Value							
		R.46 TDD	R.47 TDD	R.35-2 TDD	R.11-5 TDD	R.11-6 TDD	R.11-7 TDD	R.11-8 TDD	R.11-TDD
Reference channel									
Channel bandwidth	MHz	10	10	10	1.4	3	5	10	15
Allocated resource blocks (Note 5)		50	50	50	6	15	25	50	75
Uplink-Downlink Configuration (Note 3)		1	1	1	1	1	1	1	1
Allocated number of PDCCH symbols in normal subframes		2	2	2	4	3	3	2	2
Allocated number of PDCCH symbols in special subframes		2	2	2	2	2	2	2	2
Allocated subframes per Radio Frame (D+S)		3+2	3+2	2+2	2+2	2+2	2+2	2+2	2+2
Modulation		QPSK	16QAM	64QAM	16QAM	16QAM	16QAM	16QAM	16QA
Target Coding Rate				0.47	1/2	1/2	1/2	1/2	1/2
For Sub-Frames 4,9									
For Sub-Frames 1,6									
Information Bit Payload (Note 5)									
For Sub-Frames 4,9	Bits	5160	8760	18336	1352	3368	5736	12960	1908
For Sub-Frames 1,6		3880	7480	14688	1128	3112	5160	10680	1584
For Sub-Frame 5	Bits	N/A	N/A	N/A	N/A	N/A	N/A	N/A	N/A
For Sub-Frame 0	Bits	5160	8760	N/A	N/A	N/A	N/A	N/A	N/A
Number of Code Blocks (Notes 4 and 5)									
For Sub-Frames 4,9		1	2	3	1	1	1	3	4
For Sub-Frames 1,6		1	2	3	1	1	1	2	3
For Sub-Frame 5		N/A	N/A	N/A	N/A	N/A	N/A	N/A	N/A
For Sub-Frame 0		1	2	N/A	N/A	N/A	N/A	N/A	N/A
Binary Channel Bits (Note 5)									
For Sub-Frames 4,9	Bits	13200	26400	39600	2592	7200	12000	26400	3960
For Sub-Frames 1,6		10656	21312	31968	2304	6192	10512	21312	3211
For Sub-Frame 5	Bits	N/A	N/A	N/A	N/A	N/A	N/A	N/A	N/A
For Sub-Frame 0	Bits	12528	25056	N/A	N/A	N/A	N/A	N/A	N/A
Max. Throughput averaged over 1 frame (Note 5)	Mbps	2.324	4.124	6.604	0.496	1.296	2.179	4.498	6.98
UE Category		≥ 1	≥ 1	≥ 2	≥ 1	≥ 1	≥ 1	≥ 2	≥ 2
Note 1:	Void								
Note 2:	Reference signal, synchronization signals and PBCH allocated as per TS 36.211 [4].								
Note 3:	As per Table 4.2-2 in TS 36.211 [4].								
Note 4:	If more than one Code Block is present, an additional CRC sequence of L = 24 Bits is attached to each Code Block (other								
Note 5:	Given per component carrier per codeword								

Table A.3.4.2.1-3: Fixed Reference Channel two antenna ports

Parameter	Unit	Value	
		R.62 TDD	R.63 TDD
Reference channel			
Channel bandwidth	MHz	10	10
Allocated resource blocks (Note 4)		3	1
Uplink-Downlink Configuration (Note 3)		1	1
Allocated subframes per Radio Frame (D+S)		4+2	4+2
Modulation		16QAM	64QAM
Target Coding Rate		1/2	1/2
Information Bit Payload			
For Sub-Frames 0,4,5,9	Bits	744	408
For Sub-Frames 1,6	Bits	440	280
Number of Code Blocks			
For Sub-Frames 0,4,5,9	Code blocks	1	1
For Sub-Frames 1,6	Code blocks	1	1
Binary Channel Bits			
For Sub-Frames 0,4,5,9	Bits	1584	792
For Sub-Frames 1,6		1296	648
Max. Throughput averaged over 1 frame	Mbps	0.3856	0.2192
UE DL Category		0	0
Note 1: 2 symbols allocated to PDCCH.			
Note 2: Reference signal, synchronization signals and PBCH allocated as per TS 36.211 [4].			
Note 3: As per Table 4.2-2 in TS 36.211 [4].			
Note 4: Allocated PRB positions start from {9, 10, ..., 9+N-1}, where N is the number of allocated resource blocks.			

Table A.3.4.2.1-4: Fixed Reference Channel two antenna ports

Parameter	Unit	Value	
Reference channel		R.65 TDD	
Channel bandwidth	MHz	20	
Allocated resource blocks (Note 5)		100	
Uplink-Downlink Configuration (Note 3)		1	
Allocated subframes per Radio Frame (D+S)		2+2	
Modulation		256QAM	
Target Coding Rate			
Information Bit Payload (Note 5)			
For Sub-Frames 4,9	Bits	63776	
For Sub-Frames 1,6		46888	
For Sub-Frame 5	Bits	N/A	
For Sub-Frame 0	Bits	N/A	
Number of Code Blocks (Notes 4 and 5)			
For Sub-Frames 4,9		11	
For Sub-Frames 1,6		9	
For Sub-Frame 5		N/A	
For Sub-Frame 0		N/A	
Binary Channel Bits (Note 5)			
For Sub-Frames 4,9	Bits	115200	
For Sub-Frames 1,6		95424	
For Sub-Frame 5	Bits	N/A	
For Sub-Frame 0	Bits	N/A	
Max. Throughput averaged over 1 frame (Note 5)	Mbps	22.133	
UE Category		11-12	
UE DL Category		≥ 11	
Note 1:	2 symbols allocated to PDCCH for 20 MHz, 15 MHz and 10 MHz channel BW; 3 symbols allocated to PDCCH for 5 MHz and 3 MHz; 4 symbols allocated to PDCCH for 1.4 MHz. For subframe 1&6, only 2 OFDM symbols are allocated to PDCCH. For 256QAM reference channel 1 symbol is allocated.		
Note 2:	Reference signal, synchronization signals and PBCH allocated as per TS 36.211 [4].		
Note 3:	As per Table 4.2-2 in TS 36.211 [4].		
Note 4:	If more than one Code Block is present, an additional CRC sequence of L = 24 Bits is attached to each Code Block (otherwise L = 0 Bit).		
Note 5:	Given per component carrier per codeword		

Table A.3.4.2.1-5: Fixed Reference Channel two antenna ports when EIMTA-MainConfigServCell-r12 is configured

Parameter	Unit	Value							
Reference channel		R.67 TDD							
Channel bandwidth	MHz	10							
Allocated resource blocks (Note 5)		50							
Modulation		16QAM							
Target Coding Rate		0.4							
Dynamic Uplink-Downlink Configuration (Note 3)		0	1	2	3	4	5	6	
Allocated subframes per Radio Frame (D+S)		1+2	3+2	5+2	5+1	6+1	7+1	2+2	
Information Bit Payload (Note 5)									
For Sub-Frame 0	Bits	9912	9912	9912	9912	9912	9912	9912	9912
For Sub-Frame 1	Bits	7480	7480	7480	7480	7480	7480	7480	7480
For Sub-Frame 2	Bits	NA	NA	NA	NA	NA	NA	NA	NA
For Sub-Frame 3	Bits	NA	NA	9912	NA	NA	9912	NA	NA
For Sub-Frame 4	Bits	NA	9912	9912	NA	9912	9912	NA	NA
For Sub-Frame 5	Bits	NA	NA	NA	NA	NA	NA	NA	NA
For Sub-Frame 6	Bits	7480	7480	7480	9912	9912	9912	7480	
For Sub-Frame 7	Bits	NA	NA	NA	9912	9912	9912	NA	
For Sub-Frame 8	Bits	NA	NA	9912	9912	9912	9912	NA	
For Sub-Frame 9	Bits	NA	9912	9912	9912	9912	9912	9912	

Number of Code Blocks (Notes 4 and 5)								
For Sub-Frame 0		2	2	2	2	2	2	2
For Sub-Frame 1		2	2	2	2	2	2	2
For Sub-Frame 2		NA	NA	NA	NA	NA	NA	NA
For Sub-Frame 3		NA	NA	2	NA	NA	2	NA
For Sub-Frame 4		NA	2	2	NA	2	2	NA
For Sub-Frame 5		NA	NA	NA	NA	NA	NA	NA
For Sub-Frame 6		2	2	2	2	2	2	2
For Sub-Frame 7		NA	NA	NA	2	2	2	NA
For Sub-Frame 8		NA	NA	2	2	2	2	NA
For Sub-Frame 9		NA	2	2	2	2	2	2
Binary Channel Bits (Note 5)								
For Sub-Frame 0	Bits	25056	25056	25056	25056	25056	25056	25056
For Sub-Frame 1	Bits	21312	21312	21312	21312	21312	21312	21312
For Sub-Frame 2	Bits	NA	NA	NA	NA	NA	NA	NA
For Sub-Frame 3	Bits	NA	NA	26400	NA	NA	26400	NA
For Sub-Frame 4	Bits	NA	26400	26400	NA	26400	26400	NA
For Sub-Frame 5	Bits	NA	NA	NA	NA	NA	NA	NA
For Sub-Frame 6	Bits	21312	21312	21312	26112	26112	26112	21312
For Sub-Frame 7	Bits	NA	NA	NA	26400	26400	26400	NA
For Sub-Frame 8	Bits	NA	NA	26400	26400	26400	26400	NA
For Sub-Frame 9	Bits	NA	26400	26400	26400	26400	26400	26400
Max. Throughput averaged over 1 frame (Note 5)	Mbps	2.49	4.47	6.45	5.70	6.70	7.69	3.48
Max. Throughput averaged over 1 frame and over all dynamic UL-DL configurations (Note 5)	Mbps	5.28						
UE Category		≥ 1						
<p>Note 1: 2 OFDM symbols are allocated to PDCCH in all subframes</p> <p>Note 2: Reference signal, synchronization signals and PBCH allocated as per TS 36.211 [4].</p> <p>Note 3: As per Table 4.2-2 in TS 36.211 [4].</p> <p>Note 4: If more than one Code Block is present, an additional CRC sequence of L = 24 Bits is attached to each Code Block (otherwise L = 0 Bit).</p> <p>Note 5: Given per component carrier per codeword.</p>								

A.3.4.2.2 Four antenna ports

Table A.3.4.2.2-1: Fixed Reference Channel four antenna ports

Parameter	Unit	Value												
		R.12 TDD	R.13 TDD	R.14 TDD	R.14-1 TDD	R.14-2 TDD	R.43 TDD	R.36 TDD	R.43-1 TDD	R.43-2 TDD	R.43-3 TDD	R.43-4 TDD	R.43-5 TDD	
Reference channel														
Channel bandwidth	MHz	1.4	10	10	10	10	20	10	1.4	3	5	10	15	
Allocated resource blocks (Note 6)		6	50	50	6	3	100	50	6	15	25	50	75	
Uplink-Downlink Configuration (Note 4)		1	1	1	1	1	1	1	1	1	1	1	1	
Allocated subframes per Radio Frame (D+S)		3	3+2	2+2	2	2	2+2	2+2	2	2+2	2+2	2+2	2+2	
Modulation		QPS K	QPS K	16Q AM	16QA M	16QA M	16Q AM	64Q AM	16QA M	16QA M	16QA M	16QA M	16QA M	
Target Coding Rate		1/3	1/3	1/2	1/2	1/2	1/2	1/2	1/2	1/2	1/2	1/2	1/2	
Information Bit Payload (Note 6)														
For Sub-Frames 4,9	Bits	408	4392	12960	1544	744	25456	18336	1192	3368	5736	12960	19080	
For Sub-Frames 1,6	Bits	N/A	3240	9528	N/A	N/A	21384	15840	N/A	2856	5160	10680	15840	
For Sub-Frame 5	Bits	N/A	N/A	N/A	N/A	N/A	N/A	N/A	N/A	N/A	N/A	N/A	N/A	
For Sub-Frame 0	Bits	208	4392	N/A	N/A	N/A	N/A	N/A	N/A	N/A	N/A	N/A	N/A	
Number of Code Blocks (Notes 5 and 6)														
For Sub-Frames 4,9		1	1	3	1	1	5	3	1	1	1	3	4	
For Sub-Frames 1,6		N/A	1	2	N/A	N/A	4	3	N/A	1	1	2	3	
For Sub-Frame 5		N/A	N/A	N/A	N/A	N/A	N/A	N/A	N/A	N/A	N/A	N/A	N/A	
For Sub-Frame 0		1	1	N/A	N/A	N/A	N/A	N/A	N/A	N/A	N/A	N/A	N/A	
Binary Channel Bits (Note 6)														
For Sub-Frames 4,9	Bits	1248	12800	25600	3072	1536	51200	38400	2496	6960	11600	25600	38400	
For Sub-Frames 1,6		N/A	10256	20512	N/A	N/A	41312	30768	N/A	5952	10112	20512	30912	
For Sub-Frame 5	Bits	N/A	N/A	N/A	N/A	N/A	N/A	N/A	N/A	N/A	N/A	N/A	N/A	
For Sub-Frame 0	Bits	624	12176	N/A	N/A	N/A	N/A	N/A	N/A	N/A	N/A	N/A	N/A	
Max. Throughput averaged over 1 frame (Note 6)	Mbps	0.102	1.966	4.498	0.309	0.149	9.368	6.835	0.238	1.245	2.179	4.728	6.984	
UE Category		≥ 1	≥ 1	≥ 2	≥ 1	≥ 1	≥ 2	≥ 2	≥ 1	≥ 1	≥ 1	≥ 2	≥ 2	
Note 1:	2 symbols allocated to PDCCH for 20 MHz, 15 MHz and 10 MHz channel BW; 3 symbols allocated to PDCCH for 5 MHz and 3 MHz; 4 symbols allocated to PDCCH for 1.4 MHz. For subframe 1&6, only 2 OFDM symbols are allocated to PDCCH.													
Note 2:	For BW=1.4 MHz, the information bit payloads of special subframes are set to zero (no scheduling) to avoid problems with insufficient PDCCH performance at the test point.													
Note 3:	Reference signal, synchronization signals and PBCH allocated as per TS 36.211 [4].													
Note 4:	As per Table 4.2-2 in TS 36.211 [4].													
Note 5:	If more than one Code Block is present, an additional CRC sequence of L = 24 Bits is attached to each Code Block (otherwise L = 0 Bit).													
Note 6:	Given per component carrier per codeword.													

A.3.4.3 Reference Measurement Channels for UE-Specific Reference Symbols

A.3.4.3.1 Single antenna port (Cell Specific)

The reference measurement channels in Table A.3.4.3.1-1 apply for verifying demodulation performance for UE-specific reference symbols with one cell-specific antenna port.

Table A.3.4.3.1-1: Fixed Reference Channel for DRS

Parameter	Unit	Value					
		R.25 TDD	R.26 TDD	R.26-1 TDD	R.27 TDD	R.27-1 TDD	R.28 TDD
Reference channel		R.25 TDD	R.26 TDD	R.26-1 TDD	R.27 TDD	R.27-1 TDD	R.28 TDD
Channel bandwidth	MHz	10	10	5	10	10	10
Allocated resource blocks		50 ⁴	50 ⁴	25 ⁴	50 ⁴	18 ⁶	1
Uplink-Downlink Configuration (Note 3)		1	1	1	1	1	1
Allocated subframes per Radio Frame (D+S)		3+2	3+2	3+2	3+2	3+2	3+2
Modulation		QPSK	16QAM	16QAM	64QAM	64QAM	16QAM
Target Coding Rate		1/3	1/2	1/2	3/4	3/4	1/2
Information Bit Payload							
For Sub-Frames 4,9	Bits	4392	12960	5736	28336	10296	224
For Sub-Frames 1,6	Bits	3240	9528	4584	22920	8248	176
For Sub-Frame 5	Bits	N/A	N/A	N/A	N/A	N/A	N/A
For Sub-Frame 0	Bits	2984	9528	3880	22152	10296	224
Number of Code Blocks per Sub-Frame (Note 5)							
For Sub-Frames 4,9		1	3	1	5	2	1
For Sub-Frames 1,6		1	2	1	4	2	1
For Sub-Frame 5		N/A	N/A	N/A	N/A	N/A	N/A
For Sub-Frame 0		1	2	1	4	2	1
Binary Channel Bits Per Sub-Frame							
For Sub-Frames 4,9	Bits	12600	25200	11400	37800	13608	504
For Sub-Frames 1,6	Bits	10356	20712	10212	31068	11340	420
For Sub-Frame 5	Bits	N/A	N/A	N/A	N/A	N/A	N/A
For Sub-Frame 0	Bits	10332	20664	7752	30996	13608	504
Max. Throughput averaged over 1 frame	Mbps	1.825	5.450	2.452	12.466	4.738	0.102
UE Category		≥ 1	≥ 2	≥ 1	≥ 2	≥ 1	≥ 1
Note 1:	2 symbols allocated to PDCCH for 20 MHz, 15 MHz and 10 MHz channel BW; 3 symbols allocated to PDCCH for 5 MHz and 3 MHz; 4 symbols allocated to PDCCH for 1.4 MHz. For subframe 1&6, only 2 OFDM symbols are allocated to PDCCH.						
Note 2:	Reference signal, synchronization signals and PBCH allocated as per TS 36.211 [4].						
Note 3:	as per Table 4.2-2 in TS 36.211 [4].						
Note 4:	For R.25, R.26 and R.27, 50 resource blocks are allocated in sub-frames 1, 4, 6, 9 and 41 resource blocks (RB0–RB20 and RB30–RB49) are allocated in sub-frame 0. For R.26-1, 25 resource blocks are allocated in sub-frames 1, 4, 6, 9 and 17 resource blocks (RB0–RB7 and RB16–RB24) are allocated in sub-frame 0.						
Note 5:	If more than one Code Block is present, an additional CRC sequence of L = 24 Bits is attached to each Code Block (otherwise L = 0 Bit).						
Note 6:	Localized allocation started from RB #0 is applied.						

A.3.4.3.2 Two antenna ports (Cell Specific)

The reference measurement channels in Table A.3.4.3.2-1 apply for verifying demodulation performance for CDM-multiplexed UE specific reference symbols with two cell-specific antenna ports.

Table A.3.4.3.2-1: Fixed Reference Channel for CDM-multiplexed DM RS

Reference channel		R.31 TDD	R.32 TDD	R.32-1 TDD	R.33 TDD	R.33-1 TDD	R.34 TDD
Channel bandwidth	MHz	10	10	5	10	10	10
Allocated resource blocks		50 ⁴	50 ⁴	25 ⁴	50 ⁴	18 ⁶	50 ⁴
Uplink-Downlink Configuration (Note 3)		1	1	1	1	1	1
Allocated subframes per Radio Frame (D+S)		3+2	3+2	3+2	3+2	3+2	3+2
Modulation		QPSK	16QAM	16QAM	64QAM	64QAM	64QAM
Target Coding Rate		1/3	1/2	1/2	3/4	3/4	1/2
Information Bit Payload							
For Sub-Frames 4,9	Bits	3624	11448	5736	27376	9528	18336
For Sub-Frames 1,6		2664	7736	3112	16992	7480	11832
For Sub-Frame 5	Bits	N/A	N/A	N/A	N/A	N/A	N/A
For Sub-Frame 0	Bits	2984	9528	3496	22152	9528	14688
Number of Code Blocks per Sub-Frame (Note 5)							
For Sub-Frames 4,9		1	2	1	5	2	3
For Sub-Frames 1,6		1	2	1	3	2	2
For Sub-Frame 5		N/A	N/A	N/A	N/A	N/A	N/A
For Sub-Frame 0		1	2	1	4	2	3
Binary Channel Bits Per Sub-Frame							
For Sub-Frames 4,9	Bits	12000	24000	10800	36000	12960	36000
For Sub-Frames 1,6		7872	15744	6528	23616	10368	23616
For Sub-Frame 5	Bits	N/A	N/A	N/A	N/A	N/A	N/A
For Sub-Frame 0	Bits	9840	19680	7344	29520	12960	29520
Max. Throughput averaged over 1 frame	Mbps	1.556	4.79	2.119	11.089	4.354	7.502
UE Category		≥ 1	≥ 2	≥ 1	≥ 2	≥ 1	≥ 2
Note 1:	2 symbols allocated to PDCCH for 20 MHz, 15 MHz and 10 MHz channel BW; 3 symbols allocated to PDCCH for 5 MHz and 3 MHz; 4 symbols allocated to PDCCH for 1.4 MHz. For subframe 1&6, only 2 OFDM symbols are allocated to PDCCH.						
Note 2:	Reference signal, synchronization signals and PBCH allocated as per TS 36.211 [4].						
Note 3:	as per Table 4.2-2 in TS 36.211 [4].						
Note 4:	For R.31, R.32, R.33 and R.34, 50 resource blocks are allocated in sub-frames 4,9 and 41 resource blocks (RB0–RB20 and RB30–RB49) are allocated in sub-frame 0 and the DwPTS portion of sub-frames 1,6. For R.32-1, 25 resource blocks (RB0–RB7 and RB16–RB24) are allocated in sub-frame 0 and the DwPTS portion of sub-frames 1, 6.						
Note 5:	If more than one Code Block is present, an additional CRC sequence of L = 24 Bits is attached to each Code Block (otherwise L = 0 Bit).						
Note 6:	Localized allocation started from RB #0 is applied.						

The reference measurement channels in Table A.3.4.3.2-2 apply with two CRS antenna ports.

Table A.3.4.3.2-2: Fixed Reference Channel for CDM-multiplexed DM RS

Parameter	Unit	Value	
		R.70 TDD	R.71 TDD
Reference channel		R.70 TDD	R.71 TDD
Channel bandwidth	MHz	10	10
Allocated resource blocks		50 (Note 4)	50 (Note 4)
Uplink-Downlink Configuration (Note 3)		1	1
Allocated subframes per Radio Frame (D+S)		2+2	2+2
Modulation		QPSK	16QAM
Target Coding Rate			
For Sub-Frames 4,9		0.65	0.6
For Sub-Frames 1,6		0.54	0.5
Information Bit Payload			
For Sub-Frames 4,9	Bits	6968	12960
For Sub-Frames 1,6	Bits	4264	7736
For Sub-Frame 5	Bits	N/A	N/A
For Sub-Frame 0	Bits	N/A	N/A
Number of Code Blocks per Sub-Frame (Note 5)			
For Sub-Frames 4,9		2	3
For Sub-Frames 1,6		1	2
For Sub-Frame 5		N/A	N/A
For Sub-Frame 0		N/A	N/A
Binary Channel Bits Per Sub-Frame			
For Sub-Frames 4,9	Bits	10800	21600
For Sub-Frames 1,6	Bits	7872	15744
For Sub-Frame 5	Bits	N/A	N/A
For Sub-Frame 0	Bits	N/A	N/A
Max. Throughput averaged over 1 frame	Mbps	2.2464	4.1392
UE Category		≥ 1	≥ 2
Note 1:	3 symbols allocated to PDCCH in normal subframes and 2 symbols allocated to PDCCH in special subframes		
Note 2:	Reference signal, synchronization signals and PBCH allocated as per TS 36.211 [4].		
Note 3:	As per Table 4.2-2 in TS 36.211 [4].		
Note 4:	For R.63, and R.64, 50 resource blocks are allocated in sub-frames 4,9 and 41 resource blocks (RB0–RB20 and RB30–RB49) are allocated in the DwPTS portion of sub-frames 1,6.		
Note 5:	If more than one Code Block is present, an additional CRC sequence of L = 24 Bits is attached to each Code Block (otherwise L = 0 Bit).		

A.3.4.3.3 Two antenna ports (CSI-RS)

The reference measurement channels in Table A.3.4.3.3-1 apply for verifying demodulation performance for CDM-multiplexed UE specific reference symbols with two cell-specific antenna ports and two CSI-RS antenna ports.

Table A.3.4.3.3-1: Fixed Reference Channel for CDM-multiplexed DM RS with two CSI-RS antenna ports

Parameter	Unit	Value
Reference channel		R.51 TDD
Channel bandwidth	MHz	10
Allocated resource blocks		50 (Note 5)
Uplink-Downlink Configuration (Note 3)		1
Allocated subframes per Radio Frame (D+S)		3+2
Modulation		16QAM
Target Coding Rate		1/2
Information Bit Payload		
For Sub-Frames 4,9 (non CSI-RS subframe)	Bits	11448
For Sub-Frame 4,9	Bits	11448
For Sub-Frames 1,6	Bits	7736
For Sub-Frame 5	Bits	N/A
For Sub-Frame 0	Bits	9528
Number of Code Blocks (Note 4)		
For Sub-Frames 4, 9 (non CSI-RS subframe)	Code blocks	2
For Sub-Frames 4,9	Code blocks	2
For Sub-Frames 1,6	Code blocks	2
For Sub-Frame 5		N/A
For Sub-Frame 0	Code blocks	2
Binary Channel Bits		
For Sub-Frames 4, 9 (non CSI-RS subframe)	Bits	24000
For Sub-Frames 4,9		22800
For Sub-Frames 1,6		15744
For Sub-Frame 5	Bits	N/A
For Sub-Frame 0	Bits	19680
Max. Throughput averaged over 1 frame	Mbps	4.7896
UE Category		≥ 2
Note 1:	2 symbols allocated to PDCCH.	
Note 2:	Reference signal, synchronization signals and PBCH allocated as per TS 36.211 [4].	
Note 3:	as per Table 4.2-2 in TS 36.211 [4].	
Note 4:	If more than one Code Block is present, an additional CRC sequence of L = 24 Bits is attached to each Code Block (otherwise L = 0 Bit).	
Note 5:	50 resource blocks are allocated in sub-frames 4,9 and 41 resource blocks (RB0–RB20 and RB30–RB49) are allocated in sub-frame 0 and the DwPTS portion of sub-frames 1,6.	

The reference measurement channels in Table A3.4.3.3-2 apply for verifying demodulation performance for UE-specific reference symbols with two cell specific antenna ports and two CSI-RS antenna ports with ZP CSI-RS and NZP CSI-RS in same subframe.

Table A.3.4.3.3-2: Fixed Reference Channel for CDM-multiplexed DM RS with two CSI-RS antenna ports with ZP CSI-RS and NZP CSI-RS

Parameter	Unit	Value		
		R.52 TDD	R.53 TDD	R.54 TDD
Reference channel		R.52 TDD	R.53 TDD	R.54 TDD
Channel bandwidth	MHz	10	10	10
Allocated resource blocks		50 (Note 5)	50 (Note 5)	50 (Note 5)
Uplink-Downlink Configuration (Note 3)		1	1	1
Allocated subframes per Radio Frame (D+S)		3+2	3+2	3+2
Modulation		64QAM	64QAM	16QAM
Target Coding Rate		1/2	1/2	1/2
Information Bit Payload				
For Sub-Frame 4,9	Bits	16416	16416	11448
For Sub-Frames 1,6	Bits	11832	11832	7736
For Sub-Frame 5	Bits	n/a	n/a	n/a
For Sub-Frame 0	Bits	14688	14688	9528
Number of Code Blocks (Note 4)				
For Sub-Frames 4,9	Code blocks	3	3	2
For Sub-Frames 1,6	Code blocks	2	2	2
For Sub-Frame 5		n/a	n/a	n/a
For Sub-Frame 0	Code blocks	3	3	2
Binary Channel Bits				
For Sub-Frames 4,9		34200	33600	22800
For Sub-Frames 1,6		23616	23616	15744
For Sub-Frame 5	Bits	n/a	n/a	n/a
For Sub-Frame 0	Bits	29520	29520	19680
Max. Throughput averaged over 1 frame	Mbps	7.1184	7.1184	4.7896
UE Category		≥ 2	≥ 2	≥ 2
Note 1: 2 symbols allocated to PDCCH. Note 2: Reference signal, synchronization signals and PBCH allocated as per TS 36.211 [4]. Note 3: as per Table 4.2-2 in TS 36.211 [4]. Note 4: If more than one Code Block is present, an additional CRC sequence of L = 24 Bits is attached to each Code Block (otherwise L = 0 Bit). Note 5: 50 resource blocks are allocated in sub-frames 4, 9 and 41 resource blocks (RB0–RB20 and RB30–RB49) are allocated in sub-frame 0 and the DwPTS portion of sub-frames 1, 6.				

A.3.4.3.4 Four antenna ports (CSI-RS)

The reference measurement channels in Table A.3.4.3.4-1 apply for verifying demodulation performance for CDM-multiplexed UE specific reference symbols with two cell-specific antenna ports and four CSI-RS antenna ports.

Table A.3.4.3.4-1: Fixed Reference Channel for CDM-multiplexed DM RS with four CSI-RS antenna ports

Parameter	Unit	Value		
		R.44 TDD	R.48 TDD	R.66 TDD
Reference channel		R.44 TDD	R.48 TDD	R.66 TDD
Channel bandwidth	MHz	10	10	20
Allocated resource blocks		50 (Note 4)	50 (Note 4)	100
Uplink-Downlink Configuration (Note 3)		1	1	1
Allocated subframes per Radio Frame (D+S)		3+2	3+2	3+2
Modulation		64QAM	QPSK	256QAM
Target Coding Rate		$\frac{1}{2}$		
Information Bit Payload				
For Sub-Frames 4,9 (non CSI-RS subframe)	Bits	18336	N/A	N/A
For Sub-Frames 4,9 (CSI-RS subframe)	Bits	16416	6200	71112
For Sub-Frames 1,6		11832	4264	48936
For Sub-Frame 5	Bits	N/A	N/A	N/A
For Sub-Frame 0	Bits	14688	4968	66592
Number of Code Blocks per Sub-Frame (Note 5)				
For Sub-Frames 4,9 (non CSI-RS subframe)		3	2	N/A
For Sub-Frames 4,9 (CSI-RS subframe)		3	2	12
For Sub-Frames 1,6		2	1	8
For Sub-Frame 5		N/A	N/A	N/A
For Sub-Frame 0		3	1	11
Binary Channel Bits Per Sub-Frame				
For Sub-Frames 4,9 (non CSI-RS subframe)	Bits	36000	12000	N/A
For Sub-Frames 4,9 (CSI-RS subframe)	Bits	33600	11600	89600
For Sub-Frames 1,6		23616	7872	67584
For Sub-Frame 5	Bits	N/A	N/A	N/A
For Sub-Frame 0	Bits	29520	9840	84480
Max. Throughput averaged over 1 frame	Mbps	7.1184	2.5896	30.669
UE Category		≥ 2	≥ 1	11-12
UE DL Category		≥ 6	≥ 6	≥ 11
Note 1:	2 symbols allocated to PDCCH.			
Note 2:	Reference signal, synchronization signals and PBCH allocated as per TS 36.211 [4].			
Note 3:	as per Table 4.2-2 in TS 36.211 [4].			
Note 4:	For R.44 and R.48, 50 resource blocks are allocated in sub-frames 4,9 and 41 resource blocks (RB0–RB20 and RB30–RB49) are allocated in sub-frame 0 and the DwPTS portion of sub-frames 1,6. For R.66, 100 resource blocks are allocated in sub-frames 4, 9 and 88 resources blockes (RB0–RB43 and RB56–RB99) are allocated in sub-frame 0 and the DwPTS portion of sub-frames 1,6.			
Note 5:	If more than one Code Block is present, an additional CRC sequence of L = 24 Bits is attached to each Code Block (otherwise L = 0 Bit).			

The reference measurement channels in Table A.3.4.3.4-2 apply for verifying TDD PMI accuracy measurement with two CRS antenna ports and four CSI-RS antenna ports.

Table A.3.4.3.4-2: Fixed Reference Channel for four antenna ports (CSI-RS)

Parameter	Unit	Value		
		R.60 TDD	R.61 TDD	R.61-1 TDD
Reference channel		R.60 TDD	R.61 TDD	R.61-1 TDD
Channel bandwidth	MHz	10	10	10
Allocated resource blocks		50 ⁴	50 ⁴	39 ⁵
Uplink-Downlink Configuration (Note 3)		1	1	1
Allocated subframes per Radio Frame (D+S)		4+2	4+2	4+2
Allocated subframes per Radio Frame		10	10	10
Modulation		QPSK	16QAM	16QAM
Target Coding Rate		1/2	1/2	1/2
Information Bit Payload				
For Sub-Frames 4 and 9 (Non CSI-RS subframe)	Bits	N/A	N/A	N/A
For Sub-Frames 4 and 9 (CSI-RS subframe)	Bits	6200	11448	8760
For Sub-Frames 1,6	Bits	N/A	7736	7480
For Sub-Frame 5	Bits	N/A	N/A	N/A
For Sub-Frame 0	Bits	N/A	9528	8760
Number of Code Blocks per Sub-Frame (Note 6)				
For Sub-Frames 4 and 9 (Non CSI-RS subframe)		N/A	N/A	N/A
For Sub-Frames 4 and 9 (CSI-RS subframe)		2	2	2
For Sub-Frames 1,6		N/A	2	2
For Sub-Frame 5		N/A	N/A	N/A
For Sub-Frame 0		N/A	2	2
Binary Channel Bits Per Sub-Frame				
For Sub-Frames 4 and 9 (Non CSI-RS subframe)	Bits	N/A	N/A	N/A
For Sub-Frames 4 and 9 (CSI-RS subframe)	Bits	11600	23200	18096
For Sub-Frames 1,6	Bits	N/A	15744	14976
For Sub-Frame 5	Bits	N/A	N/A	N/A
For Sub-Frame 0	Bits	N/A	19680	18720
Max. Throughput averaged over 1 frame	Mbps	1.24	4.7896	4.1240
UE Category		≥ 1	≥ 2	≥ 1
Note 1:	2 symbols allocated to PDCCH for 20 MHz, 15 MHz and 10 MHz channel BW; 3 symbols allocated to PDCCH for 5 MHz and 3 MHz; 4 symbols allocated to PDCCH for 1.4 MHz. For subframe 1&6, only 2 OFDM symbols are allocated to PDCCH.			
Note 2:	Reference signal, synchronization signals and PBCH allocated as per TS 36.211 [4].			
Note 3:	As per Table 4.2-2 in TS 36.211 [4].			
Note 4:	For R. 60 and R.61, 50 resource blocks are allocated in sub-frames 4,9 and 41 resource blocks (RB0–RB20 and RB30–RB49) are allocated in sub-frame 0 and the DwPTS portion of sub-frames 1,6.			
Note 5:	For R. 61-1, 39 resource blocks (RB0–RB20 and RB30–RB47) are allocated in sub-frame 0, 1, 4, 6 and 9.			
Note 6:	If more than one Code Block is present, an additional CRC sequence of L = 24 Bits is attached to each Code Block (otherwise L = 0 Bit).			
Note 7:	Localized allocation started from RB #0 is applied.			

The reference measurement channels in Table A.3.4.3.4-3 apply for verifying demodulation performance for CDM-multiplexed UE specific reference symbols with two cell-specific antenna ports and four CSI-RS antenna ports.

Table A.3.4.3.4-3: Fixed Reference Channel for CDM-multiplexed DM RS with four CSI-RS antenna ports

Parameter	Unit	Value
Reference channel		R.64 TDD
Channel bandwidth	MHz	10
Allocated resource blocks (Note 4)		6
Uplink-Downlink Configuration (Note 3)		1
Allocated subframes per Radio Frame (D+S)		4+2
Modulation		QPSK
Target Coding Rate		1/3
Information Bit Payload		
For Sub-Frames 4,9 (non CSI-RS subframe)	Bits	504
For Sub-Frames 4,9 (CSI-RS subframe)	Bits	504
For Sub-Frames 1,6		256
For Sub-Frames 0,5	Bits	504
Number of Code Blocks per Sub-Frame		
For Sub-Frames 4,9 (non CSI-RS subframe)	Code blocks	1
For Sub-Frames 4,9 (CSI-RS subframe)	Code blocks	1
For Sub-Frames 1,6	Code blocks	1
For Sub-Frames 0,5	Code blocks	1
Binary Channel Bits Per Sub-Frame		
For Sub-Frames 4,9 (non CSI-RS subframe)	Bits	1440
For Sub-Frames 4,9 (CSI-RS subframe)	Bits	1352
For Sub-Frames 1,6		1152
For Sub-Frames 0,5	Bits	1440
Max. Throughput averaged over 1 frame	Mbps	0.2528
UE DL Category		0
Note 1:	2 symbols allocated to PDCCH.	
Note 2:	Reference signal, synchronization signals and PBCH allocated as per TS 36.211 [4].	
Note 3:	as per Table 4.2-2 in TS 36.211 [4].	
Note 4:	Allocated PRB positions start from {9, 10, ..., 9+N-1}, where N is the number of allocated resource blocks.	

The reference measurement channels in Table A.3.4.3.4-4 apply for verifying demodulation performance for CDM-multiplexed UE specific reference symbols with two cell-specific antenna ports and four CSI-RS antenna ports.

Table A.3.4.3.4-4: Fixed Reference Channel for CDM-multiplexed DM RS with four CSI-RS antenna ports

Parameter	Unit	Value
Reference channel		R.69 TDD
Channel bandwidth	MHz	10
Allocated resource blocks		50 (Note 4)
Uplink-Downlink Configuration (Note 3)		1
Allocated subframes per Radio Frame (D+S)		2+2
Modulation		QPSK
Target Coding Rate		
For Sub-Frame 4(CSI-RS subframe)		0.8
For Sub-Frame 9 (non CSI-RS subframe)		0.74
For Sub-Frames 1,6		0.61
Information Bit Payload		
For Sub-Frame 4(CSI-RS subframe)	Bits	7992
For Sub-Frame 9 (non CSI-RS subframe)	Bits	7992
For Sub-Frames 1,6	Bits	4776
For Sub-Frame 5	Bits	N/A
For Sub-Frame 0	Bits	N/A
Number of Code Blocks per Sub-Frame (Note 5)		
For Sub-Frame 4(CSI-RS subframe)		2
For Sub-Frame 9 (non CSI-RS subframe)		2
For Sub-Frames 1,6		1
For Sub-Frame 5		N/A
For Sub-Frame 0		N/A
Binary Channel Bits Per Sub-Frame		
For Sub-Frame 4(CSI-RS subframe)	Bits	10000
For Sub-Frame 9 (non CSI-RS subframe)	Bits	10800
For Sub-Frames 1,6	Bits	7872
For Sub-Frame 5	Bits	N/A
For Sub-Frame 0	Bits	N/A
Max. Throughput averaged over 1 frame	Mbps	2.5536
UE Category		≥ 1
Note 1: 3 symbols allocated to PDCCH. Note 2: Reference signal, synchronization signals and PBCH allocated as per TS 36.211 [4]. Note 3: As per Table 4.2-2 in TS 36.211 [4]. Note 4: 50 resource blocks are allocated in sub-frames 4,9 and 41 resource blocks (RB0–RB20 and RB30–RB49) are allocated in the DwPTS portion of sub-frames 1,6. Note 5: If more than one Code Block is present, an additional CRC sequence of L = 24 Bits is attached to each Code Block (otherwise L = 0 Bit).		

A.3.4.3.5 Eight antenna ports (CSI-RS)

The reference measurement channels in Table A.3.4.3.5-1 apply for verifying demodulation performance for CDM-multiplexed UE specific reference symbols with two cell-specific antenna ports and eight CSI-RS antenna ports.

Table A.3.4.3.5-1: Fixed Reference Channel for CDM-multiplexed DM RS with eight CSI-RS antenna ports

Parameter	Unit	Value
Reference channel		R.50 TDD
Channel bandwidth	MHz	10
Allocated resource blocks		50 (Note 4)
Uplink-Downlink Configuration (Note 3)		1
Allocated subframes per Radio Frame (D+S)		3+2
Modulation		QPSK
Target Coding Rate		1/3
Information Bit Payload		
For Sub-Frames 4,9 (non CSI-RS subframe)	Bits	3624
For Sub-Frames 4,9 (CSI-RS subframe)	Bits	3624
For Sub-Frames 1,6		2664
For Sub-Frame 5	Bits	N/A
For Sub-Frame 0	Bits	2984
Number of Code Blocks per Sub-Frame (Note 5)		
For Sub-Frames 4,9 (non CSI-RS subframe)		1
For Sub-Frames 4,9 (CSI-RS subframe)		1
For Sub-Frames 1,6		1
For Sub-Frame 5		N/A
For Sub-Frame 0		1
Binary Channel Bits Per Sub-Frame		
For Sub-Frames 4,9 (non CSI-RS subframe)	Bits	12000
For Sub-Frames 4,9 (CSI-RS subframe)	Bits	10400
For Sub-Frames 1,6		7872
For Sub-Frame 5	Bits	N/A
For Sub-Frame 0	Bits	9840
Max. Throughput averaged over 1 frame	Mbps	1.556
UE Category		≥ 1
Note 1: 2 symbols allocated to PDCCH. Note 2: Reference signal, synchronization signals and PBCH allocated as per TS 36.211 [4]. Note 3: as per Table 4.2-2 in TS 36.211 [4]. Note 4: 50 resource blocks are allocated in sub-frames 4,9 and 41 resource blocks (RB0–RB20 and RB30–RB49) are allocated in sub-frame 0 and the DwPTS portion of sub-frames 1,6. Note 5: If more than one Code Block is present, an additional CRC sequence of L = 24 Bits is attached to each Code Block (otherwise L = 0 Bit).		

The reference measurement channels in Table A.3.4.3.5-2 apply for verifying TDD PMI accuracy measurement with two CRS antenna ports and eight CSI-RS antenna ports.

Table A.3.4.3.5-2: Fixed Reference Channel for eight antenna ports (CSI-RS)

Parameter	Unit	Value	
		R.45 TDD	R.45-1 TDD
Reference channel		R.45 TDD	R.45-1 TDD
Channel bandwidth	MHz	10	10
Allocated resource blocks		50 ⁴	39
Uplink-Downlink Configuration (Note 3)		1	1
Allocated subframes per Radio Frame (D+S)		4+2	4+2
Allocated subframes per Radio Frame		5	5
Modulation		16QAM	16QAM
Target Coding Rate		1/2	1/2
Information Bit Payload			
For Sub-Frames 4 and 9 (Non CSI-RS subframe)	Bits	N/A	N/A
For Sub-Frames 4 and 9 (CSI-RS subframe)	Bits	11448	8760
For Sub-Frames 1,6	Bits	7736	7480
For Sub-Frame 5	Bits	N/A	N/A
For Sub-Frame 0	Bits	9528	8760
Number of Code Blocks per Sub-Frame (Note 5)			
For Sub-Frames 4 and 9 (Non CSI-RS subframe)		N/A	N/A
For Sub-Frames 4 and 9 (CSI-RS subframe)		2	2
For Sub-Frames 1,6		2	2
For Sub-Frame 5		N/A	N/A
For Sub-Frame 0		2	2
Binary Channel Bits Per Sub-Frame			
For Sub-Frames 4 and 9 (Non CSI-RS subframe)	Bits	N/A	N/A
For Sub-Frames 4 and 9 (CSI-RS subframe)	Bits	22400	17472
For Sub-Frames 1,6	Bits	15744	14976
For Sub-Frame 5	Bits	N/A	N/A
For Sub-Frame 0	Bits	19680	18720
Max. Throughput averaged over 1 frame	Mbps	4.7896	4.1240
UE Category		≥ 2	≥ 1
Note 1:	2 symbols allocated to PDCCH for 20 MHz, 15 MHz and 10 MHz channel BW; 3 symbols allocated to PDCCH for 5 MHz and 3 MHz; 4 symbols allocated to PDCCH for 1.4 MHz. For subframe 1&6, only 2 OFDM symbols are allocated to PDCCH.		
Note 2:	Reference signal, synchronization signals and PBCH allocated as per TS 36.211 [4].		
Note 3:	As per Table 4.2-2 in TS 36.211 [4].		
Note 4:	For For R.45, 50 resource blocks are allocated in sub-frames 4,9 and 41 resource blocks (RB0–RB20 and RB30–RB49) are allocated in sub-frame 0 and the DwPTS portion of sub-frames 1,6. For R.45-1, 39 resource blocks are allocated in sub-frames 0,4,9 and the DwPTS portion of sub-frames 1,6 (RB0–RB20 and RB30–RB47).		
Note 5:	If more than one Code Block is present, an additional CRC sequence of L = 24 Bits is attached to each Code Block (otherwise L = 0 Bit).		
Note 6:	Localized allocation started from RB #0 is applied.		

A.3.5 Reference measurement channels for PDCCH/PCFICH performance requirements

A.3.5.1 FDD

Table A.3.5.1-1: Reference Channel FDD

Parameter	Unit	Value				
		R.15 FDD	R.15-1 FDD	R.15-2 FDD	R.16 FDD	R.17 FDD
Reference channel						
Number of transmitter antennas		1	2	2	2	4
Channel bandwidth	MHz	10	10	10	10	5
Number of OFDM symbols for PDCCH	symbols	2	3	2	2	2
Aggregation level	CCE	8	8	8	4	2
DCI Format		Format 1	Format 1	Format 1	Format 2	Format 2
Cell ID		0	0	0	0	0
Payload (without CRC)	Bits	31	31	31	43	42

A.3.5.2 TDD

Table A.3.5.2-1: Reference Channel TDD

Parameter	Unit	Value				
		R.15 TDD	R.15-1 TDD	R.15-2 TDD	R.16 TDD	R.17 TDD
Reference channel						
Number of transmitter antennas		1	2	2	2	4
Channel bandwidth	MHz	10	10	10	10	5
Number of OFDM symbols for PDCCH	symbols	2	3	2	2	2
Aggregation level	CCE	8	8	8	4	2
DCI Format		Format 1	Format 1	Format 1	Format 2	Format 2
Cell ID		0	0	0	0	0
Payload (without CRC)	Bits	34	34	34	46	45

A.3.6 Reference measurement channels for PHICH performance requirements

Table A.3.6-1: Reference Channel FDD/TDD

Parameter	Unit	Value				
		R.18	R.19	R.19-1	R.20	R.24
Reference channel						
Number of transmitter antennas		1	2	2	4	1
Channel bandwidth	MHz	10	10	5	5	10
User roles (Note 1)		W I1 I2	W I1 I2	W I1 I2	W I1 I2	W I1
Resource allocation (Note 2)		(0,0) (0,1) (0,4)	(0,0) (0,1) (0,4)	(0,0) (0,1) (0,4)	(0,0) (0,1) (0,4)	(0,0) (0,1)
Power offsets (Note 3)	dB	-4 0 -3	-4 0 -3	-4 0 -3	-4 0 -3	+3 0
Payload (Note 4)		A R R	A R R	A R R	A R R	A R
Note 1: W=wanted user, I1=interfering user 1, I2=interfering user 2. Note 2: The resource allocation per user is given as (N_group_PHICH, N_seq_PHICH). Note 3: The power offsets (per user) represent the difference of the power of BPSK modulated symbol per PHICH relative to the first interfering user. Note 4: A=fixed ACK, R=random ACK/NACK.						

A.3.7 Reference measurement channels for PBCH performance requirements

Table A.3.7-1: Reference Channel FDD/TDD

Parameter	Unit	Value		
		R.21	R.22	R.23
Reference channel		R.21	R.22	R.23
Number of transmitter antennas		1	2	4
Channel bandwidth	MHz	1.4	1.4	1.4
Modulation		QPSK	QPSK	QPSK
Target coding rate		40/1920	40/1920	40/1920
Payload (without CRC)	Bits	24	24	24

A.3.8 Reference measurement channels for MBMS performance requirements

A.3.8.1 FDD

Table A.3.8.1-1: Fixed Reference Channel QPSK R=1/3

Parameter	Unit	PMCH					
		Value					
Reference channel		R.40 FDD			R.37 FDD		
Channel bandwidth	MHz	1.4	3	5	10	15	20
Allocated resource blocks		6			50		
Allocated subframes per Radio Frame (Note 1)		6			6		
Modulation		QPSK			QPSK		
Target Coding Rate		1/3			1/3		
Information Bit Payload (Note 2)							
For Sub-Frames 1,2,3,6,7,8	Bits	408			3624		
For Sub-Frames 0,4,5,9	Bits	N/A			N/A		
Number of Code Blocks per Subframe (Note 3)		1			1		
Binary Channel Bits Per Subframe							
For Sub-Frames 1,2,3,6,7,8	Bits	1224			10200		
For Sub-Frames 0,4,5,9	Bits	N/A			N/A		
MBMS UE Category		≥ 1			≥ 1		
Note 1:	For FDD mode, up to 6 subframes (#1/2/3/6/7/8) are available for MBMS, in line with TS 36.331.						
Note 2:	2 OFDM symbols are reserved for PDCCH; and reference signal allocated as per TS 36.211.						
Note 3:	If more than one Code Block is present, an additional CRC sequence of L = 24 Bits is attached to each Code Block (otherwise L = 0 Bit).						

Table A.3.8.1-2: Fixed Reference Channel 16QAM R=1/2

Parameter	PMCH						
	Unit	Value					
Reference channel					R.38 FDD		
Channel bandwidth	MHz	1.4	3	5	10	15	20
Allocated resource blocks					50		
Allocated subframes per Radio Frame (Note 1)					6		
Modulation					16QAM		
Target Coding Rate					1/2		
Information Bit Payload (Note 2)							
For Sub-Frames 1,2,3,6,7,8	Bits				9912		
For Sub-Frames 0,4,5,9	Bits				N/A		
Number of Code Blocks per Subframe (Note 3)					2		
Binary Channel Bits Per Subframe							
For Sub-Frames 1,2,3,6,7,8	Bits				20400		
For Sub-Frames 0,4,5,9	Bits				N/A		
MBMS UE Category					≥ 1		
Note 1: For FDD mode, up to 6 subframes (#1/2/3/6/7/8) are available for MBMS, in line with TS 36.331. Note 2: 2 OFDM symbols are reserved for PDCCH; and reference signal allocated as per TS 36.211. Note 3: If more than one Code Block is present, an additional CRC sequence of L = 24 Bits is attached to each Code Block (otherwise L = 0 Bit).							

Table A.3.8.1-3: Fixed Reference Channel 64QAM R=2/3

Parameter	PMCH						
	Unit	Value					
Reference channel				R.39-1 FDD	R.39 FDD		
Channel bandwidth	MHz	1.4	3	5	10	15	20
Allocated resource blocks				25	50		
Allocated subframes per Radio Frame(Note1)				6	6		
Modulation				64QAM	64QAM		
Target Coding Rate				2/3	2/3		
Information Bit Payload (Note 2)							
For Sub-Frames 1,2,3,6,7,8	Bits			9912	19848		
For Sub-Frames 0,4,5,9	Bits			N/A	N/A		
Number of Code Blocks per Sub-Frame (Note 3)				2	4		
Binary Channel Bits Per Subframe							
For Sub-Frames 1,2,3,6,7,8	Bits			15300	30600		
For Sub-Frames 0,4,5,9	Bits			N/A	N/A		
MBMS UE Category				≥ 1	≥ 2		
Note 1: For FDD mode, up to 6 subframes (#1/2/3/6/7/8) are available for MBMS, in line with TS 36.331. Note 2: 2 OFDM symbols are reserved for PDCCH; and reference signal allocated as per TS 36.211. Note 3: If more than one Code Block is present, an additional CRC sequence of L = 24 Bits is attached to each Code Block (otherwise L = 0 Bit).							

A.3.8.2 TDD

Table A.3.8.2-1: Fixed Reference Channel QPSK R=1/3

Parameter	PMCH						
	Unit	Value					
Reference channel		R.40 TDD			R.37 TDD		
Channel bandwidth	MHz	1.4	3	5	10	15	20
Allocated resource blocks		6			50		
Uplink-Downlink Configuration(Note 1)		5			5		
Allocated subframes per Radio Frame		5			5		
Modulation		QPSK			QPSK		
Target Coding Rate		1/3			1/3		
Information Bit Payload (Note 2)							
For Sub-Frames 3,4,7,8,9	Bits	408			3624		
For Sub-Frames 0,1,2,5,6	Bits	N/A			N/A		
Number of Code Blocks per Subframe (Note 3)		1			1		
Binary Channel Bits Per Subframe							
For Sub-Frames 3,4,7,8,9	Bits	1224			10200		
For Sub-Frames 0,1,2,5,6	Bits	N/A			N/A		
MBMS UE Category		≥ 1			≥ 1		
Note 1: For TDD mode, in line with TS 36.331, Uplink-Downlink Configuration 5 is proposed, up to 5 subframes (#3/4/7/8/9) are available for MBMS. Note 2: 2 OFDM symbols are reserved for PDCCH; reference signal allocated as per TS 36.211. Note 3: If more than one Code Block is present, an additional CRC sequence of L = 24 Bits is attached to each Code Block (otherwise L = 0 Bit).							

Table A.3.8.2-2: Fixed Reference Channel 16QAM R=1/2

Parameter	PMCH						
	Unit	Value					
Reference channel					R.38 TDD		
Channel bandwidth	MHz	1.4	3	5	10	15	20
Allocated resource blocks					50		
Uplink-Downlink Configuration(Note 1)					5		
Allocated subframes per Radio Frame					5		
Modulation					16QAM		
Target Coding Rate					1/2		
Information Bit Payload (Note 2)							
For Sub-Frames 3,4,7,8,9	Bits				9912		
For Sub-Frames 0,1,2,5,6	Bits				N/A		
Number of Code Blocks per Subframe (Note 3)					2		
Binary Channel Bits Per Subframe							
For Sub-Frames 3,4,7,8,9	Bits				20400		
For Sub-Frames 0,1,2,5,6	Bits				N/A		
MBMS UE Category					≥ 1		
Note 1: For TDD mode, in line with TS 36.331, Uplink-Downlink Configuration 5 is proposed, up to 5 subframes (#3/4/7/8/9) are available for MBMS. Note 2: 2 OFDM symbols are reserved for PDCCH; reference signal allocated as per TS 36.211. Note 3: If more than one Code Block is present, an additional CRC sequence of L = 24 Bits is attached to each Code Block (otherwise L = 0 Bit).							

Table A.3.8.2-3: Fixed Reference Channel 64QAM R=2/3

Parameter	PMCH						
	Unit	Value					
Reference channel				R.39-1TDD	R.39 TDD		
Channel bandwidth	MHz	1.4	3	5	10	15	20
Allocated resource blocks				25	50		
Uplink-Downlink Configuration(Note 1)				5	5		
Allocated subframes per Radio Frame				5	5		
Modulation				64QAM	64QAM		
Target Coding Rate				2/3	2/3		
Information Bit Payload (Note 2)							
For Sub-Frames 3,4,7,8,9	Bits			9912	19848		
For Sub-Frames 0,1,2,5,6	Bits			N/A	N/A		
Number of Code Blocks per Sub-Frame (Note 3)				2	4		
Binary Channel Bits Per Subframe							
For Sub-Frames 3,4,7,8,9	Bits			15300	30600		
For Sub-Frames 0,1,2,5,6	Bits			N/A	N/A		
MBMS UE Category				≥ 1	≥ 2		
Note 1:	For TDD mode, in line with TS 36.331, Uplink-Downlink Configuration 5 is proposed, up to 5 subframes (#3/4/7/8/9) are available for MBMS.						
Note 2:	2 OFDM symbols are reserved for PDCCH; reference signal allocated as per TS 36.211.						
Note 3:	If more than one Code Block is present, an additional CRC sequence of L = 24 Bits is attached to each Code Block (otherwise L = 0 Bit).						

A.3.9 Reference measurement channels for sustained downlink data rate provided by lower layers

A.3.9.1 FDD

Table A.3.9.1-1: Fixed Reference Channel for sustained data-rate test (FDD 64QAM)

Parameter	Unit	Value							
		R.31-1 FDD	R.31-2 FDD	R.31-3 FDD	R.31-3A FDD	R.31-3C FDD	R.31-4 FDD	R.31-4B FDD	R.31-5 FDD
Reference channel									
Channel bandwidth	MHz	10	10	20	10	15	20	15	15
Allocated resource blocks (Note 8)		Note 5	Note 6	Note 7	Note 6	Note 10	Note 7	Note 11	Note 9
Allocated subframes per Radio Frame		10	10	10	10	10	10	10	10
Modulation		64QAM	64QAM	64QAM	64QAM	64QAM	64QAM	64QAM	64QAM
Coding Rate									
For Sub-Frame 1,2,3,4,6,7,8,9,		0.40	0.59	0.59	0.85	0.87	0.88	0.85	0.85
For Sub-Frame 5		0.40	0.64	0.62	0.89	0.88	0.87	0.87	0.91
For Sub-Frame 0		0.40	0.63	0.61	0.90	0.91	0.90	0.88	0.88
Information Bit Payload (Note 8)									
For Sub-Frames 1,2,3,4,6,7,8,9	Bits	10296	25456	51024	36696	51024	75376	55056	55056
For Sub-Frame 5	Bits	10296	25456	51024	35160	51024	71112	52752	52752
For Sub-Frame 0	Bits	10296	25456	51024	36696	51024	75376	55056	55056
Number of Code Blocks (Notes 3 and 8)									
For Sub-Frames 1,2,3,4,6,7,8,9	Bits	2	5	9	6	9	13	9	9
For Sub-Frame 5	Bits	2	5	9	6	9	12	9	9
For Sub-Frame 0	Bits	2	5	9	6	9	13	9	9
Binary Channel Bits (Note 8)									
For Sub-Frames 1,2,3,4,6,7,8,9	Bits	26100	43200	86400	43200	58752	86400	64800	64800
For Sub-Frame 5	Bits	26100	39744	82080	39744	57888	82080	60480	60480
For Sub-Frame 0	Bits	26100	40752	83952	40752	56304	83952	62352	62352
Number of layers		1	2	2	2	2	2	2	2
Max. Throughput averaged over 1 frame (Note 8)	Mbps	10.296	25.456	51.024	36.542	51.024	74.950	54.826	54.826
UE Categories		≥ 1	≥ 2	≥ 2	≥ 2	≥ 3	≥ 3	≥ 4	≥ 3
Note 1:	1 symbol allocated to PDCCH for all tests.								
Note 2:	Reference signal, synchronization signals and PBCH allocated as per TS 36.211 [4].								
Note 3:	If more than one Code Block is present, an additional CRC sequence of L = 24 Bits is attached to each Code Block (otherwise L = 0 Bit).								
Note 4:	Resource blocks $n_{PRB} = 0..2$ are allocated for SIB transmissions in sub-frame 5 for all bandwidths.								
Note 5:	Resource blocks $n_{PRB} = 6..14,30..49$ are allocated for the user data in all sub-frames.								
Note 6:	Resource blocks $n_{PRB} = 3..49$ are allocated for the user data in sub-frame 5, and resource blocks $n_{PRB} = 0..49$ in sub-frames 0,1,2,3,4,6,7,8,9.								
Note 7:	Resource blocks $n_{PRB} = 4..99$ are allocated for the user data in sub-frame 5, and resource blocks $n_{PRB} = 0..99$ in sub-frames 0,1,2,3,4,6,7,8,9.								
Note 8:	Given per component carrier per codeword.								
Note 9:	Resource blocks $n_{PRB} = 4..74$ are allocated for the user data in sub-frame 5, and resource blocks $n_{PRB} = 0..74$ in sub-frames 0,1,2,3,4,6,7,8,9.								
Note 10:	Resource blocks $n_{PRB} = 4..71$ are allocated for the user data in sub-frames 0,1,2,3,4,5,6,7,8,9.								
Note 11:	Resource blocks $n_{PRB} = 4..74$ are allocated for the user data in sub-frame 5, and resource blocks $n_{PRB} = 0..74$ in sub-frames 0,1,2,3,4,6,7,8,9.								

Table A.3.9.1-2: Fixed Reference Channel for sustained data-rate test (FDD 64QAM)

Parameter	Unit	Value						
Reference channel		R.31-6 FDD						
Channel bandwidth	MHz	5						
Allocated resource blocks (Note 5)		Note 4						
Allocated subframes per Radio Frame		9						
Modulation		64QAM						
Coding Rate								
For Sub-Frame 1,2,3,4,6,7,8,9,		0.85						
For Sub-Frame 5		N/A						
For Sub-Frame 0		0.83						
Information Bit Payload (Note 5)								
For Sub-Frames 1,2,3,4,6,7,8,9	Bits	18336						
For Sub-Frame 5	Bits	N/A						
For Sub-Frame 0	Bits	15840						
Number of Code Blocks (Notes 3 and 5)								
For Sub-Frames 1,2,3,4,6,7,8,9	Bits	3						
For Sub-Frame 5	Bits	N/A						
For Sub-Frame 0	Bits	3						
Binary Channel Bits (Note 5)								
For Sub-Frames 1,2,3,4,6,7,8,9	Bits	21600						
For Sub-Frame 5	Bits	N/A						
For Sub-Frame 0	Bits	19152						
Number of layers		2						
Max. Throughput averaged over 1 frame (Note 5)	Mbps	17.837						
UE Categories		≥ 2						
Note 1:	1 symbol allocated to PDCCH for all tests.							
Note 2:	Reference signal, synchronization signals and PBCH allocated as per TS 36.211 [4].							
Note 3:	If more than one Code Block is present, an additional CRC sequence of L = 24 Bits is attached to each Code Block (otherwise L = 0 Bit).							
Note 4:	Resource blocks $n_{PRB} = 0..24$ in sub-frames 0,1,2,3,4,6,7,8,9.							
Note 5:	Given per component carrier per codeword.							
Note 6:	$N_g=1/6$.							

Table A.3.9.1-3: Fixed Reference Channel for sustained data-rate test (FDD 256QAM)

Parameter	Unit	Value			
		R.68 FDD	R.68-1 FDD	R.68-2 FDD	R.68-3 FDD
Reference channel					
Channel bandwidth	MHz	20	15	10	5
Allocated resource blocks (Note 4)		Note 5	Note 6	Note 7	Note 8
Allocated subframes per Radio Frame		10	10	10	10
Modulation		256QAM	256QAM	256QAM	256QAM
Coding Rate					
For Sub-Frames 3,4,8,9		0.85	0.88	0.85	0.85
For Sub-Frames 1,2,6,7		0.74	0.74	0.74	0.77
For Sub-Frame 5		0.75	0.77	0.77	0.79
For Sub-Frame 0		0.76	0.77	0.78	0.84
Information Bit Payload (Note 4)					
For Sub-Frames 3,4,8,9	Bits	97896	75376	48936	24496
For Sub-Frames 1,2,6,7		84760	63776	42368	21384
For Sub-Frame 5	Bits	81176	61664	40576	19848
For Sub-Frame 0	Bits	84760	63776	42368	21384
Number of Code Blocks (Notes 3 and 4)					
For Sub-Frames 3,4,8,9	Bits	16	13	8	4
For Sub-Frames 1,2,6,7		14	11	7	4
For Sub-Frame 5	Bits	14	11	7	4
For Sub-Frame 0	Bits	14	11	7	4
Binary Channel Bits (Note 4)					
For Sub-Frames 3,4,8,9	Bits	115200	86400	57600	28800
For Sub-Frames 1,2,6,7		115200	86400	57600	28800
For Sub-Frame 5	Bits	109440	80640	52992	25344
For Sub-Frame 0	Bits	111936	83136	54336	25536
Number of layers		2	2	2	2
Max. Throughput averaged over 1 frame (Note 4)	Mbps	89.656	68.205	44.816	22.475
UE Categories		11-12	11-12	11-12	11-12
UE DL Categories		≥ 11	≥ 11	≥ 11	≥ 11
Note 1:	1 symbol allocated to PDCCH for all tests.				
Note 2:	Reference signal, synchronization signals and PBCH allocated as per TS 36.211 [4].				
Note 3:	If more than one Code Block is present, an additional CRC sequence of L = 24 Bits is attached to each Code Block (otherwise L = 0 Bit).				
Note 4:	Given per component carrier per codeword.				
Note 5:	Resource blocks $n_{PRB} = 4..99$ are allocated for the user data in sub-frame 5, and resource blocks $n_{PRB} = 0..99$ in sub-frames 0,1,2,3,4,6,7,8,9.				
Note 6:	Resource blocks $n_{PRB} = 4..74$ are allocated for the user data in sub-frame 5, and resource blocks $n_{PRB} = 0..74$ in sub-frames 0,1,2,3,4,6,7,8,9.				
Note 7:	Resource blocks $n_{PRB} = 3..49$ are allocated for the user data in sub-frame 5, and resource blocks $n_{PRB} = 0..49$ in sub-frames 0,1,2,3,4,6,7,8,9.				
Note 8:	Resource blocks $n_{PRB} = 2..24$ are allocated for the user data in sub-frame 5, and resource blocks $n_{PRB} = 0..24$ in sub-frames 0,1,2,3,4,6,7,8,9.				

A.3.9.2 TDD

Table A.3.9.2-1: Fixed Reference Channel for sustained data-rate test (TDD 64QAM)

Parameter	Unit	Value								
		R.31-1 TDD	R.31-2 TDD	R.31-3 TDD	R.31- 3A TDD	R.31-4 TDD	R.31- 4A TDD	R.31-5 TDD	R.31- 5A TDD	R.31-6 TDD
Reference channel										
Channel bandwidth	MHz	10	10	20	15	20	20	15	15	10
Allocated resource blocks		Note 6	Note 7	Note 8	Note 9	Note 8	Note 8	Note 11	Note 11	Note 7
Uplink-Downlink Configuration (Note 3)		5	5	5	1	1	2	1	2	1
Number of HARQ Processes per component carrier	Processes	15	15	15	7	7	10	7	10	7
Allocated subframes per Radio Frame (D+S)		8+1	8+1	8+1	4	4	6+2	4	6+2	4
Modulation		64QAM	64QAM	64QAM	64QAM	64QAM	64QAM	64QAM	64QAM	64QAM
Target Coding Rate										
For Sub-Frames 4,9		0.40	0.59	0.59	0.87	0.88	0.88	0.85	0.85	0.85
For Sub-Frames 3,8		0.40	0.59	0.59	N/A	N/A	0.88	N/A	0.85	N/A
For Sub-Frame 7		0.40	0.59	0.59	N/A	N/A	N/A	N/A	N/A	N/A
For Sub-Frames 0		0.40	0.62	0.61	0.90	0.90	0.90	0.88	0.88	0.90
For Sub-Frames 1		N/A	N/A	N/A	N/A	N/A	N/A	N/A	N/A	N/A
For Sub-Frames 5		0.40	0.64	0.62	0.88	0.87	0.87	0.87	0.87	0.88
For Sub-Frames 6		0.40	0.60	0.60	N/A	N/A	N/A	N/A	N/A	N/A
Information Bit Payload										
For Sub-Frames 4,9	Bits	10296	25456	51024	51024	75376	75376	55056	55056	36696
For Sub-Frames 3,8	Bits	10296	25456	51024	0	0	75376	0	55056	0
For Sub-Frame 7	Bits	10296	25456	51024	0	0	N/A	0	N/A	0
For Sub-Frame 0	Bits	10296	25456	51024	51024	75376	75376	55056	55056	36696
For Sub-Frame 1	Bits	0	0	0	0	0	0	0	0	0
For Sub-Frame 5	Bits	10296	25456	51024	51024	71112	71112	52752	52752	35160
For Sub-Frame 6	Bits	10296	25456	51024	0	0	0	0	0	0
Number of Code Blocks per Sub-Frame (Note 4)										
For Sub-Frames 4,9		2	5	9	9	13	13	9	9	6
For Sub-Frames 3,8		2	5	9	N/A	N/A	13	N/A	9	N/A
For Sub-Frame 7		2	5	9	N/A	N/A	N/A	N/A	N/A	N/A
For Sub-Frame 0		2	5	9	9	13	13	9	9	6
For Sub-Frame 1		N/A	N/A	N/A	N/A	N/A	N/A	N/A	N/A	N/A
For Sub-Frame 5		2	5	9	9	12	12	9	9	6
For Sub-Frame 6	Bits	2	5	9	n/a	N/A	N/A	N/A	N/A	N/A
Binary Channel Bits Per Sub-Frame										
For Sub-Frames 4,9	Bits	26100	43200	86400	58752	86400	86400	64800	64800	43200
For Sub-Frames 3,8	Bits	26100	43200	86400	0	0	86400	0	64800	0
For Sub-Frame 7	Bits	26100	43200	86400	0	0	86400	0	64800	0
For Sub-Frame 0	Bits	26100	41184	84384	56736	84384	84384	62784	62784	41184
For Sub-Frame 1	Bits	0	0	0	0	0	0	0	0	0
For Sub-Frame 5	Bits	26100	40176	82512	58320	82512	82512	60912	60912	40176
For Sub-Frame 6	Bits	26100	42768	85968	N/A	N/A	0	N/A	0	N/A
Number of layers		1	2	2	2	2	2	2	2	2
Max. Throughput averaged over 1 frame (Note 10)	Mbps	8.237	20.365	40.819	20.409	29.724	52.337	25.330	38.309	14.525
UE Category		≥ 1	≥ 2	≥ 2	≥ 2	≥ 3	≥ 3	≥ 3	≥ 3	≥ 2
Note 1:	1 symbol allocated to PDCCH for all tests.									
Note 2:	Reference signal, synchronization signals and PBCH allocated as per TS 36.211 [4].									
Note 3:	As per Table 4.2-2 in TS 36.211 [4].									
Note 4:	If more than one Code Block is present, an additional CRC sequence of L = 24 Bits is attached to each Code Block (otherwise L = 0 Bit).									
Note 5:	Resource blocks $n_{PRB} = 0..2$ are allocated for SIB transmissions in sub-frame 5 for all bandwidths.									
Note 6:	Resource blocks $n_{PRB} = 6..14,30..49$ are allocated for the user data in all subframes.									
Note 7:	Resource blocks $n_{PRB} = 3..49$ are allocated for the user data in sub-frame 5, and resource blocks $n_{PRB} = 0..49$ in the available downlink sub-frames according to uplink downlink configurations used .									

- Note 8: Resource blocks $n_{PRB} = 4..99$ are allocated for the user data in sub-frame 5, and resource blocks $n_{PRB} = 0..99$ in sub-frames 0,3,4,6,7,8,9.
- Note 9: Resource blocks $n_{PRB} = 4..71$ are allocated for the user data in all sub-frames
- Note10: Given per component carrier per codeword.
- Note11: Resource blocks $n_{PRB} = 4..74$ are allocated for the user data in sub-frame 5, and resource blocks $n_{PRB} = 0..74$ in other downlink sub-frames.

Table A.3.9.2-2: Fixed Reference Channel for sustained data-rate test (TDD 256QAM)

Parameter	Unit	Value					
		R.68 TDD	R.68-1 TDD	R.68-2 TDD	R.68-3 TDD	R.68-4 TDD	
Reference channel							
Channel bandwidth	MHz	20	15	10	20	15	
Allocated resource blocks	PRB	Note 6	Note 7	Note 8	Note 6	Note 7	
Uplink-Downlink Configuration (Note 3)		1	1	1	[2]	[2]	
Number of HARQ Processes per component carrier	Processes	7	7	7	[10]	[10]	
Allocated subframes per Radio Frame (D+S)		4+2	4+2	4+2	[6+2]	[6+2]	
Modulation		256QAM	256QAM	256QAM	256QAM	256QAM	
Target Coding Rate							
For Sub-Frame 0		0.76	0.77	0.78	0.76	0.77	
For Sub-Frame 1		N/A	N/A	N/A	N/A	N/A	
For Sub-Frames 3		N/A	N/A	N/A	0.74	0.79	
For Sub-Frames 4		0.74	0.79	0.74	0.74	0.79	
For Sub-Frame 5		0.74	0.76	0.76	0.74	0.76	
For Sub-Frame 6		N/A	N/A	N/A	[N/A]	[N/A]	
For Sub-Frame 7		N/A	N/A	N/A	[N/A]	[N/A]	
For Sub-Frames 8		N/A	N/A	N/A	0.85	0.88	
For Sub-Frames 9		0.85	0.88	0.85	0.85	0.88	
Information Bit Payload							
For Sub-Frame 0	Bits	84760	63776	42368	84760	63776	
For Sub-Frame 1	Bits	0	0	0	0	0	
For Sub-Frames 3	Bits	N/A	N/A	N/A	84760	63776	
For Sub-Frames 4	Bits	84760	63776	42368	84760	63776	
For Sub-Frame 5	Bits	81176	61664	40576	81176	61664	
For Sub-Frame 6	Bits	0	0	0	[0]	[0]	
For Sub-Frame 7		N/A	N/A	N/A	[N/A]	[N/A]	
For Sub-Frames 8	Bits	N/A	N/A	N/A	97896	75376	
For Sub-Frames 9	Bits	97896	75376	48936	97896	75376	
Number of Code Blocks per Sub-Frame (Note 4)							
For Sub-Frame 0		14	11	7	14	11	
For Sub-Frame 1		N/A	N/A	N/A	N/A	N/A	
For Sub-Frames 3		N/A	N/A	N/A	14	11	
For Sub-Frames 4		14	11	7	14	11	
For Sub-Frame 5		14	11	7	14	11	
For Sub-Frame 6		N/A	N/A	N/A	[N/A]	[11]	
For Sub-Frame 7		N/A	N/A	N/A	[N/A]	[11]	
For Sub-Frames 8		N/A	N/A	N/A	16	13	
For Sub-Frames 9		16	13	8	16	13	
Binary Channel Bits Per Sub-Frame							
For Sub-Frame 0	Bits	112512	83712	54912	112512	83712	
For Sub-Frame 1	Bits	0	0	0	0	0	
For Sub-Frames 3	Bits	N/A	N/A	N/A	115200	86400	
For Sub-Frames 4	Bits	115200	86400	57600	115200	86400	
For Sub-Frame 5		110016	81216	53568	110016	81216	
For Sub-Frame 6	Bits	0	0	0	[0]	[0]	
For Sub-Frame 7		N/A	N/A	N/A	[N/A]	[N/A]	
For Sub-Frames 8	Bits	N/A	N/A	N/A	115200	86400	
For Sub-Frames 9	Bits	115200	86400	57600	115200	86400	
Number of layers		2	2	2	2	2	
Max. Throughput averaged over 1 frame (Note 5)	Mbps	34.859	26.459	17.425	[53.125]	[40.374]	
UE Categories		11-12	11-12	11-12	11-12	11-12	
UE DL Categories		≥ 11	≥ 11	≥ 11	≥ 11	≥ 11	

Note 1: 1 symbol allocated to PDCCH for all tests.

Note 2: Reference signal, synchronization signals and PBCH allocated as per TS 36.211 [4].

Note 3: As per Table 4.2-2 in TS 36.211 [4].

Note 4: If more than one Code Block is present, an additional CRC sequence of L = 24 Bits is attached to each Code Block (otherwise L = 0 Bit).

Note 5: Given per component carrier per codeword.

Note 6: Resource blocks $n_{PRB} = 4..99$ are allocated for the user data in sub-frame 5, and resource blocks $n_{PRB} = 0..99$ in other

	downlink sub-frames.
Note 7:	Resource blocks $n_{PRB} = 4..74$ are allocated for the user data in sub-frame 5, and resource blocks $n_{PRB} = 0..74$ in other downlink sub-frames.
Note 8:	Resource blocks $n_{PRB} = 3..49$ are allocated for the user data in sub-frame 5, and resource blocks $n_{PRB} = 0..49$ in the available downlink sub-frames according to uplink downlink configurations used.

A.3.9.3 FDD (EPDCCH scheduling)

Table A.3.9.3-1: Fixed Reference Channel for sustained data-rate test with EPDCCH scheduling (FDD)

Parameter	Unit	Value						
		R.31E-1 FDD	R.31E-2 FDD	R.31E-3 FDD	R.31E-3A FDD	R.31E-3C FDD	R.31E-4 FDD	R.31E-4B FDD
Reference channel								
Channel bandwidth	MHz	10	10	20	10	15	20	15
Allocated resource blocks (Note 8)		Note 5	Note 6	Note 7	Note 6	Note 9	Note 7	Note 10
Allocated subframes per Radio Frame		10	10	10	10	10	10	10
Modulation		64QAM	64QAM	64QAM	64QAM	64QAM	64QAM	64QAM
Coding Rate (subframes with PDCCH USS monitoring)								
For Sub-Frame 1,2,3,4,6,7,8,9,		0.3972	0.5926	0.5933	0.8533	0.8725	0.8763	0.8533
For Sub-Frame 5		0.3972	0.6441	0.6246	0.8889	0.8855	0.8702	0.8762
For Sub-Frame 0		0.3972	0.6282	0.6106	0.9046	0.9105	0.9018	0.8868
Coding Rate (subframes with EPDCCH USS monitoring)								
For Sub-Frame 1,2,3,4,6,7,8,9,		0.4114	0.6047	0.5993	0.8707	0.8855	0.8851	0.8649
For Sub-Frame 5		0.4114	0.6584	0.6312	0.9086	0.8990	0.8794	0.8889
For Sub-Frame 0		0.4114	0.6418	0.6170	0.9242	0.9246	0.9112	0.8993
Information Bit Payload (Note 8)								
For Sub-Frames 1,2,3,4,6,7,8,9	Bits	10296	25456	51024	36696	51024	75376	55056
For Sub-Frame 5	Bits	10296	25456	51024	35160	51024	71112	52752
For Sub-Frame 0	Bits	10296	25456	51024	36696	51024	75376	55056
Number of Code Blocks (Notes 3 and 8)								
For Sub-Frames 1,2,3,4,6,7,8,9	Bits	2	5	9	6	9	13	9
For Sub-Frame 5	Bits	2	5	9	6	9	12	9
For Sub-Frame 0	Bits	2	5	9	6	9	13	9
Binary Channel Bits (Note 8) (subframes with PDCCH USS monitoring)								
For Sub-Frames 1,2,3,4,6,7,8,9	Bits	26100	43200	86400	43200	58752	86400	64800
For Sub-Frame 5	Bits	26100	39744	82080	39744	57888	82080	60480
For Sub-Frame 0	Bits	26100	40752	83952	40752	56304	83952	62352
Binary Channel Bits (Note 8) (subframes with EPDCCH USS monitoring)								
For Sub-Frames 1,2,3,4,6,7,8,9	Bits	25200	42336	85536	42336	57888	85536	63936
For Sub-Frame 5	Bits	25200	38880	81216	38880	57024	81216	59616
For Sub-Frame 0	Bits	25200	39888	83088	39888	55440	83088	61488
Number of layers		1	2	2	2	2	2	2
Max. Throughput averaged over 1 frame (Note 8)	Mbps	10.296	25.456	51.024	36.542	51.024	74.950	54.826
UE Categories		≥ 1	≥ 2	≥ 2	≥ 2	≥ 3	≥ 3	≥ 4
Note 1:	1 symbol allocated to PDCCH for all tests.							
Note 2:	Reference signal, synchronization signals and PBCH allocated as per TS 36.211.							
Note 3:	If more than one Code Block is present, an additional CRC sequence of $L = 24$ Bits is attached to each Code Block (otherwise $L = 0$ Bit).							
Note 4:	Resource blocks $n_{PRB} = 0..2$ are allocated for SIB transmissions in sub-frame 5 for all bandwidths.							
Note 5:	Resource blocks $n_{PRB} = 6..14,30..49$ are allocated for the user data in all sub-frames.							
Note 6:	Resource blocks $n_{PRB} = 3..49$ are allocated for the user data in sub-frame 5, and resource blocks $n_{PRB} = 0..49$ in sub-frames 0,1,2,3,4,6,7,8,9.							
Note 7:	Resource blocks $n_{PRB} = 4..99$ are allocated for the user data in sub-frame 5, and resource blocks $n_{PRB} = 0..99$ in sub-frames 0,1,2,3,4,6,7,8,9.							

Note 8: Given per component carrier per codeword.
 Note 9: Resource blocks $n_{PRB} = 4..71$ are allocated for the user data in sub-frames 0,1,2,3,4,5,6,7,8,9.
 Note 10: Resource blocks $n_{PRB} = 4..74$ are allocated for the user data in sub-frame 5, and resource blocks $n_{PRB} = 0..74$ in sub-frames 0,1,2,3,4,6,7,8,9.

A.3.9.4 TDD (EPDCCH scheduling)

Table A.3.9.4-1: Fixed Reference Channel for sustained data-rate with EPDCCH scheduling (TDD)

Parameter	Unit	Value				
		R.31E-1 TDD	R.31E-2 TDD	R.31E-3 TDD	R.31E-3A TDD	R.31E-4 TDD
Reference channel						
Channel bandwidth	MHz	10	10	20	15	20
Allocated resource blocks		Note 6	Note 7	Note 8	Note 9	Note 8
Uplink-Downlink Configuration (Note 3)		5	5	5	1	1
Number of HARQ Processes per component carrier	Processes	15	15	15	7	7
Allocated subframes per Radio Frame (D+S)		8+1	8+1	8+1	4	4
Coding Rate (subframes with PDCCH USS monitoring)						
For Sub-Frames 4,9		0.3972	0.5926	0.5933	0.8725	0.8763
For Sub-Frames 3,7,8		0.3972	0.5926	0.5933	N/A	N/A
For Sub-Frames 1		N/A	N/A	N/A	N/A	N/A
For Sub-Frames 5		0.3972	0.6372	0.6213	0.8790	0.8656
For Sub-Frames 6		0.3972	0.5986	0.5963	N/A	N/A
For Sub-Frames 0		0.3972	0.6216	0.6075	0.9036	0.8972
Coding Rate (subframes with EPDCCH USS monitoring)						
For Sub-Frames 4,9		0.4114	0.6047	0.5993	0.8856	0.8851
For Sub-Frames 3,7,8		0.4114	0.6047	0.5993	N/A	N/A
For Sub-Frames 1		N/A	N/A	N/A	N/A	N/A
For Sub-Frames 5		0.4114	0.6512	0.6279	0.8922	0.8748
For Sub-Frames 6		0.4114	0.6109	0.6024	N/A	N/A
For Sub-Frames 0		0.4114	0.6349	0.6138	0.9175	0.9065
Information Bit Payload						
For Sub-Frames 4,9	Bits	10296	25456	51024	51024	75376
For Sub-Frames 3,7,8	Bits	10296	25456	51024	N/A	N/A
For Sub-Frame 1	Bits	0	0	0	N/A	N/A
For Sub-Frame 5	Bits	10296	25456	51024	51024	71112
For Sub-Frame 6	Bits	10296	25456	51024	N/A	N/A
For Sub-Frame 0	Bits	10296	25456	51024	51024	75376
Number of Code Blocks per Sub-Frame (Note 4)						
For Sub-Frames 4,9		2	5	9	9	13
For Sub-Frames 3,7,8		2	5	9	N/A	N/A
For Sub-Frame 1		N/A	N/A	N/A	N/A	N/A
For Sub-Frame 5		2	5	9	9	12
For Sub-Frame 6	Bits	2	5	9	N/A	N/A
For Sub-Frame 0		2	5	9	9	13
Binary Channel Bits per Sub-Frame (subframes with PDCCH USS monitoring)						
For Sub-Frames 4,9	Bits	26100	43200	86400	58752	86400
For Sub-Frames 3,7,8	Bits	26100	43200	86400	N/A	N/A
For Sub-Frame 1	Bits	0	0	0	N/A	N/A
For Sub-Frame 5	Bits	26100	40176	82512	58320	82512
For Sub-Frame 6	Bits	26100	42768	85968	N/A	N/A
For Sub-Frame 0	Bits	26100	41184	84384	56736	84384
Binary Channel Bits per Sub-Frame (subframes with EPDCCH USS monitoring)						

monitoring)						
For Sub-Frames 4,9	Bits	25200	42336	85536	57888	85536
For Sub-Frames 3,7,8	Bits	25200	42336	85536	N/A	N/A
For Sub-Frame 1	Bits	0	0	0	N/A	N/A
For Sub-Frame 5	Bits	25200	39312	81648	57456	81648
For Sub-Frame 6	Bits	25200	41904	85104	N/A	N/A
For Sub-Frame 0	Bits	25200	40320	83520	55872	83520
Number of layers		1	2	2	2	2
Max. Throughput averaged over 1 frame (Note 10)	Mbps	8.237	20.365	40.819	20.409	29.724
UE Category		≥ 1	≥ 2	≥ 2	≥ 2	≥ 3
Note 1:	1 symbol allocated to PDCCH for all tests.					
Note 2:	Reference signal, synchronization signals and PBCH allocated as per TS 36.211 [4].					
Note 3:	As per Table 4.2-2 in TS 36.211 [4].					
Note 4:	If more than one Code Block is present, an additional CRC sequence of L = 24 Bits is attached to each Code Block (otherwise L = 0 Bit).					
Note 5:	Resource blocks $n_{PRB} = 0..2$ are allocated for SIB transmissions in sub-frame 5 for all bandwidths.					
Note 6:	Resource blocks $n_{PRB} = 6..14,30..49$ are allocated for the user data in all subframes.					
Note 7:	Resource blocks $n_{PRB} = 3..49$ are allocated for the user data in sub-frame 5, and resource blocks $n_{PRB} = 0..49$ in sub-frames 0,3,4,6,7,8,9.					
Note 8:	Resource blocks $n_{PRB} = 4..99$ are allocated for the user data in sub-frame 5, and resource blocks $n_{PRB} = 0..99$ in sub-frames 0,3,4,6,7,8,9.					
Note 9:	Resource blocks $n_{PRB} = 4..71$ are allocated for the user data in all sub-frames					
Note10:	Given per component carrier per codeword.					

A.3.10 Reference Measurement Channels for EPDCCH performance requirements

A.3.10.1 FDD

Table A.3.10.1-1: Reference Channel FDD

Parameter	Unit	Value					
		R.55 FDD	R.56 FDD	R.57 FDD	R.58 FDD	R.59 FDD	
Reference channel							
Number of transmitter antennas		2	2	2	2	2	
Channel bandwidth	MHz	10	10	10	10	10	
Number of OFDM symbols for PDCCH	symbols	2	2	1	1	1	
Aggregation level	ECCE	4	16	2	8	2	
DCI Format		2A	2A	2C	2C	2D	

A.3.10.2 TDD

Table A.3.10.2-1: Reference Channel TDD

Parameter	Unit	Value					
		R.55 TDD	R.56 TDD	R.57 TDD	R.58 TDD	R.59 TDD	
Reference channel							
Number of transmitter antennas		2	2	2	2	2	
Channel bandwidth	MHz	10	10	10	10	10	
Number of OFDM symbols for PDCCH	symbols	2	2	1	1	1	
Aggregation level	CCE	4	16	2	8	2	
DCI Format		2A	2A	2C	2C	2D	

A.4 CSI reference measurement channels

This section defines the DL signal applicable to the reporting of channel status information (Clause 9.2, 9.3 and 9.5).

In Table A.4-1 are specified the reference channels. Table A.4-13 specifies the mapping of CQI index to modulation coding scheme, which complies with the CQI definition specified in Section 7.2.3 of [6].

Table A.4-0: Void

Table A.4-1: CSI reference measurement channels

RMC Name	Duplex	CH-BW	Alloc. RB-s	UL/DL Config	Alloc. SF-s	MCS Scheme	Nr. HARQ Proc.	Max. nr HARQ Trans.	Notes
1 CRS Port									
RC.1 FDD	FDD	10	50	-		MCS.1	8	1	
RC.1A FDD	FDD	10	50			MCS.1A	8	1	
RC.1 TDD	TDD	10	50	Note 3		MCS.1	10	1	
RC.1A TDD	TDD	20	100	Note 3		MCS.1B	10	1	
RC.3 FDD	FDD	10	6	-		MCS.10	8	1	
RC.3 TDD	TDD	10	6	Note 3		MCS.10	10 or 7 (Note 9)	1	
RC.4 FDD	FDD	10	15	-		MCS.15	8	1	Note 6
RC.4 TDD	TDD	10	15	Note 3		MCS.15	10	1	Note 6
RC.5 FDD	FDD	10	3	-		MCS.17	8	1	
RC.5 TDD	TDD	10	3	Note 3		MCS.17	10	1	
RC.14 FDD	FDD	5	25	-		MCS.14	8	1	
RC.15 FDD	FDD	5	15	-		MCS.15	8	1	Note 6
RC.16 FDD	FDD/HD-FDD	10	2			MCS.20	8	1	Note 8,10
RC.16 TDD	TDD	10	2	Note 3		MCS.20	10	1	Note 8
2 CRS Ports									
RC.2 FDD	FDD	10	50	-		MCS.2	8	1	
RC.2 TDD	TDD	10	50	Note 3		MCS.2	10 or 7 (Note 9)	1	
RC.6 FDD	FDD	10	15	-		MCS.16	8	1	Note 6
RC.6 TDD	TDD	10	15	Note 3		MCS.16	7	1	Note 6
4 CRS Ports									
RC.17 FDD	FDD	10	50	-		MCS.18	8	1	
RC.17 TDD	TDD	10	50	Note 3		MCS.18	7	1	
1 CRS Port + CSI-RS									
RC.8 FDD	FDD	10	6	-	Non CSI-RS	MCS.11	8	1	
					2 CSI-RS	MCS.12			
RC.8A FDD	FDD	10	6	-	Non CSI-RS	MCS.11A	8	1	
					2 CSI-RS	MCS.12A			
RC.8 TDD	TDD	10	6	Note 3	Non CSI-RS	MCS.11	10	1	
					2 CSI-RS	MCS.12			
RC.8A TDD	TDD	20	8	Note 3	Non CSI-RS	MCS.11B	10	1	
					2 CSI-RS	MCS.12B			
RC.9 FDD	FDD	10	50	-	Non CSI-RS	MCS.3	8	1	
					2 CSI-RS	MCS.4			
RC.9 TDD	TDD	10	50	Note 3	Non CSI-RS	MCS.3	7	1	
					2 CSI-RS	MCS.4			
2 CRS Port + CSI-RS									

RC.7 FDD	FDD	10	50	-	Non CSI-RS	MCS.5	8	1	
					4 CSI-RS	MCS.7			
RC.7 TDD	TDD	10	50	Note 3	Non CSI-RS	MCS.5	10	1	
					8 CSI-RS	MCS.8			
RC.11 FDD	FDD	10	50	-	Non CSI-RS	MCS.5	8	1	
					2 CSI-RS	MCS.6			
RC.11 TDD	TDD	10	50	Note 3	Non CSI-RS	MCS.5	10	1	
					2 CSI-RS	MCS.6			
RC.18 FDD	FDD	10	6	-	Non CSI-RS	MCS.13	8	1	
					4 CSI-RS	MCS.19			
RC.18 TDD	TDD	10	6	Note 3	Non CSI-RS	MCS.13	7	1	
					4 CSI-RS	MCS.19			
RC.17 TDD	TDD	10	6	Note 3	4 ZP-CSI-RS	MCS.21	10	1	
RC.18 TDD	TDD	10	6	Note 3	4 ZP-CSI-RS	MCS.22	10	1	
RC.19 TDD	TDD	10	41	Note3	4 ZP-CSI-RS	MCS.23	10	1	Note 11
RC.20 TDD	TDD	10	50	Note3	Non CSI-RS	MCS.24	10	1	
					2 CSI-RS, 4 ZP-CSI-RS	MCS.25			
1 CRS Port + CSI-RS + CSI-IM									
RC.13 FDD	FDD	10	50	-	Non CSI-RS/IM	MCS.3	8	1	
					CSI-RS/IM	N/A			
RC.13 TDD	TDD	10	50	Note 3	Non CSI-RS/IM	MCS.3	10	1	
					CSI-RS/IM	N/A			
2 CRS Port + CSI-RS + CSI-IM									
RC.10 FDD	FDD	10	50	-	Non CSI-RS	MCS.5	8	1	
					4 CSI-RS, 1 CSI process	MCS.8			
RC.10 TDD	TDD	10	50	Note 3	Non CSI-RS	MCS.5	10	1	
					8 CSI-RS, 1 CSI process	MCS.9			
RC.12 FDD	FDD	10	6	-	Non CSI-RS/IM	MCS.13	8	1	
					CSI-RS/IM	N/A			
RC.12 TDD	TDD	10	6	Note 3	Non CSI-RS/IM	MCS.13	10	1	
					CSI-RS/IM	N/A			
<p>Note 1: 3 symbols allocated to PDCCH.</p> <p>Note 2: For FDD only subframes 1, 2, 3, 4, 6, 7, 8 and 9 are allocated to avoid PBCH and synchronization signal overhead.</p> <p>Note 3: TDD UL-DL configuration as specified in the individual tests.</p>									

- | | |
|----------|--|
| Note 4: | For TDD when UL-DL configuration 1 is used only subframes 4 and 9 are allocated to avoid PBCH and synchronization signal overhead. |
| Note 5: | For TDD when UL-DL configuration 2 is used only subframes 3, 4, 8, and 9 are allocated to avoid PBCH and synchronization signal overhead. |
| Note 6: | Centered within the Transmission Bandwidth Configuration (Figure 5.6-1). |
| Note 7: | Only subframes 2, 3, 4, 7, 8 and 9 are allocated to avoid PBCH and synchronization signal overhead. |
| Note 8: | Allocate PDSCH on 5th and 6th PRBs within a subband. |
| Note 9: | The number of HARQ processes is 10 for TDD UL/DL configuration 2 and 7 for TDD UL/DL configuration 1. |
| Note 10: | The downlink subframes are scheduled at the 1st, 2nd, 8th, 9th, 16th, 17th, 18th, 24th, 26th, 32nd, 33rd, 34th subframes every 40ms. Information bit payload is available if downlink subframe is scheduled.(starting from 0th subframe) |
| Note 11: | 41 resource blocks (RB0–RB20 and RB30–RB49) are allocated in subframe 0 and 5 in RC.19 TDD. |

Table A.4-1a: Void
Table A.4-1b: Void
Table A.4-1c: Void
Table A.4-1d: Void
Table A.4-1e: Void
Table A.4-2: Void
Table A.4-2a: Void
Table A.4-2b: Void
Table A.4-2c: Void
Table A.4-2d: Void
Table A.4-2e: Void
Table A.4-3: Void
Table A.4-3a: Void
Table A.4-3b: Void
Table A.4-3c: Void
Table A.4-3d: Void
Table A.4-3e: Void
Table A.4-3f: Void
Table A.4-3g: Void
Table A.4-3h: Void
Table A.4-3i: Void
Table A.4-3j: Void
Table A.4-3k: Void
Table A.4-3l: Void
Table A.4-3m: Void
Table A.4-4: Void
Table A.4-4a: Void
Table A.4-4b: Void
Table A.4-5: Void
Table A.4-5a: Void

Table A.4-5b: Void

Table A.4-6: Void

Table A.4-6a: Void

Table A.4-6b: Void

Table A.4-6c: Void

Table A.4-6d: Void

Table A.4-6e: Void

Table A.4-6f: Void

Table A.4-7: Void

Table A.4-8: Void

Table A.4-9: Void

Table A.4-10: Void

Table A.4-11: Void

Table A.4-12: Void

Table A.4-13: Mapping of CQI Index to Modulation coding scheme (MCS)

CQI Index			0	1	2	3	4	5	6	7	8	9	10	11	12	13	14	15	Notes
Target Coding Rate				0.0762	0.1172	0.1885	0.3008	0.4385	0.5879	0.3691	0.4785	0.6016	0.4551	0.5537	0.6504	0.7539	0.8525	0.9258	
Modulation			0.0762	QPSK						16QAM			64QAM						
MCS Scheme	PRB	Available RE-s	Imcs																
MCS.1	50	6300	DTX	0	0	2	4	6	8	11	13	16	18	21	23	25	27	27	
MCS.2	50	6000	DTX	0	0	2	4	6	8	11	13	15	18	20	22	24	26	27	
MCS.3	50	5700	DTX	0	0	2	4	6	8	10	13	15	17	19	21	23	25	26	
MCS.4	50	5600	DTX	0	0	2	4	6	7	10	12	14	17	19	21	23	25	26	
MCS.5	50	5400	DTX	0	0	2	3	5	7	10	12	14	17	19	21	23	24	25	
MCS.6	50	5300	DTX	0	0	1	3	5	7	10	12	14	17	19	21	22	24	25	
MCS.7	50	5200	DTX	0	0	1	3	5	7	10	12	14	17	18	20	22	24	25	
MCS.8	50	5000	DTX	0	0	1	3	5	7	10	12	13	17	18	20	22	23	24	
MCS.9	50	4800	DTX	0	0	1	3	5	7	10	12	13	17	18	20	22	23	24	
MCS.10	6	756	DTX	0	0	2	4	6	8	11	13	16	19	21	23	25	27	27	
MCS.11	6	684	DTX	0	0	2	4	6	8	11	13	14	17	20	21	23	25	27	
MCS.12	6	672	DTX	0	0	1	4	6	8	10	12	14	17	19	21	23	25	26	
MCS.13	6	648	DTX	0	0	1	3	5	7	10	12	14	17	19	21	22	24	25	
MCS.14	25	3150	DTX	0	0	2	4	6	8	11	13	16	18	21	23	25	27	27	
MCS.15	15	1890	DTX	0	0	2	4	6	8	11	13	16	18	21	23	25	27	27	
MCS.16	15	1800	DTX	0	0	2	4	6	8	11	13	15	18	20	22	24	26	27	
MCS.17	3	378	DTX	0	1	2	5	7	9	12	13	16	19	21	23	25	27	27	
MCS.18	50	5800	DTX	0	0	2	4	6	8	11	13	15	17	20	22	23	26	27	
MCS.19	6	624	DTX	0	0	1	3	5	7	10	12	14	17	18	20	22	24	25	
MCS.20	2	252	DTX	0	0	2	4	6	8	11	13	16	19	21	23	23	23	23	
MCS.21	6	696	DTX	0	0	2	4	6	8	11	13	15	18	20	21	24	25	27	

MCS.22	6	624	DTX	0	0	1	3	5	7	10	12	14	15	19	20	22	24	24	
MCS.23	41	4264	DTX	0	0	1	3	5	7	10	12	14	15	18	20	22	24	24	
MCS.24	50	5400	DTX	0	0	2	3	5	7	10	12	14	15	19	21	23	24	25	
MCS.25	50	5100	DTX	0	0	1	3	5	7	8	12	13	15	18	20	22	23	24	
<p>Note 1: Mapping between Imcs and TBS according to Tables 7.1.7.1-1 and 7.1.7.2.1-1 in TS 36.213 [6].</p> <p>Note 2: 3 symbols allocated to PDCCH.</p> <p>Note 3: Sub-frame#0 and #5 are not used for the corresponding requirement except for [MCS.23]. The next subframe (i.e. sub-frame#1 or #6) shall be used for potential retransmissions.</p>																			

Table A.4-14: Mapping of CQI Index to Modulation coding scheme (Modulation and TBS index Table 2 and 4-bit CQI Table 2 are used)

CQI Index			0	1	2	3	4	5	6	7	8	9	10	11	12	13	14	15	Notes
Target Spectral Efficiency			0.1523	0.3770	0.8770	1.4766	1.9141	2.4063	2.7305	3.3223	3.9023	4.5234	5.1152	5.5547	6.2266	6.9141	7.4063		
MCS Scheme	PRB	Available RE-s	Imcs																
MCS.1A	50	6300	DTX	0	1	3	5	7	10	11	14	16	18	20	22	24	26	26	
MCS.1B	100	12600	DTX	0	1	3	5	7	10	11	14	15	18	20	22	24	26	26	
Note 1: Mapping between Imcs and CQI Index according to Tables 7.1.7.1-1A, 7.1.7.2.1-1 and 7.2.3-2 in TS 36.213 [6].																			
Note 2: 3 symbols allocated to PDCCH.																			
Note 3: Sub-frame#0 and #5 are not used for the corresponding requirement. The next subframe (i.e. sub-frame#1 or #6) shall be used for potential retransmissions.																			

Table A.4-15: Mapping of CQI Index to Modulation coding scheme (Modulation and TBS index Table 2 and 4-bit CQI Table 2 are used)

CQI Index			0	1	2	3	4	5	6	7	8	9	10	11	12	13	14	15	Notes
Target Spectral Efficiency			0.1523	0.3770	0.8770	1.4766	1.9141	2.4063	2.7305	3.3223	3.9023	4.5234	5.1152	5.5547	6.2266	6.9141	7.4063		
MCS Scheme	PRB	Available RE-s	Imcs																
MCS.11A	6	684	DTX	0	1	3	5	7	8	10	13	14	16	18	20	22	24	25	
MCS.12A	6	672	DTX	0	1	3	5	6	8	10	12	14	16	18	20	22	24	25	
MCS.11B	8	912	DTX	0	1	3	5	7	9	10	13	14	16	18	19	22	24	26	
MCS.12B	8	896	DTX	0	1	3	5	6	8	10	12	14	16	18	19	22	24	25	
Note 1: Mapping between Imcs and CQI Index according to Tables 7.1.7.1-1A, 7.1.7.2.1-1 and 7.2.3-2 in TS 36.213 [6].																			
Note 2: 3 symbols allocated to PDCCH.																			
Note 3: Sub-frame#0 and #5 are not used for the corresponding requirement. The next subframe (i.e. sub-frame#1 or #6) shall be used for potential retransmissions.																			

A.5 OFDMA Channel Noise Generator (OCNG)

A.5.1 OCNG Patterns for FDD

The following OCNG patterns are used for modelling allocations to virtual UEs (which are not under test) and/or allocations used for MBSFN. The OCNG pattern for each sub frame specifies the allocations that shall be filled with OCNG, and furthermore, the relative power level of each such allocation.

In each test case the OCNG is expressed by parameters OCNG_RA and OCNG_RB which together with a relative power level (γ) specifies the PDSCH EPRE-to-RS EPRE ratios in OFDM symbols with and without reference symbols, respectively. The relative power, which is used for modelling boosting per virtual UE allocation, is expressed by:

$$\gamma_i = PDSCH_{i_RA} / OCNG_RA = PDSCH_{i_RB} / OCNG_RB,$$

where γ_i denotes the relative power level of the i :th virtual UE. The parameter settings of OCNG_RA, OCNG_RB, and the set of relative power levels γ are chosen such that when also taking allocations to the UE under test into account, as given by a PDSCH reference channel, a constant transmitted power spectral density that is constant on an OFDM symbol basis is targeted.

Moreover the OCNG pattern is accompanied by a PCFICH/PDCCH/PHICH reference channel which specifies the control region. For any aggregation and PHICH allocation, the PDCCH and any unused PHICH groups are padded with resource element groups with a power level given respectively by PDCCH_RA/RB and PHICH_RA/RB as specified in the test case such that a total power spectral density in the control region that is constant on an OFDM symbol basis is targeted.

For the performance requirements of UE with the CA capability, the OCNG patterns apply for each CC.

A.5.1.1 OCNG FDD pattern 1: One sided dynamic OCNG FDD pattern

This OCNG Pattern fills with OCNG all empty PRB-s (PRB-s with no allocation of data or system information) of the DL sub-frames, when the unallocated area is continuous in frequency domain (one sided).

Table A.5.1.1-1: OP.1 FDD: One sided dynamic OCNG FDD Pattern

Relative power level γ_{PRB} [dB]			PDSCH Data
Subframe			
0	5	1 – 4, 6 – 9	
Allocation			
First unallocated PRB – Last unallocated PRB	First unallocated PRB – Last unallocated PRB	First unallocated PRB – Last unallocated PRB	
0	0	0	Note 1
Note 1: These physical resource blocks are assigned to an arbitrary number of virtual UEs with one PDSCH per virtual UE; the data transmitted over the OCNG PDSCHs shall be uncorrelated pseudo random data, which is QPSK modulated. The parameter γ_{PRB} is used to scale the power of PDSCH.			
Note 2: If two or more transmit antennas with CRS are used in the test, the OCNG shall be transmitted to the virtual users by all the transmit antennas with CRS according to transmission mode 2. The parameter γ_{PRB} applies to each antenna port separately, so the transmit power is equal between all the transmit antennas with CRS used in the test. The antenna transmission modes are specified in section 7.1 in 3GPP TS 36.213.			

A.5.1.2 OCNG FDD pattern 2: Two sided dynamic OCNG FDD pattern

This OCNG Pattern fills with OCNG all empty PRB-s (PRB-s with no allocation of data or system information) of the DL sub-frames, when the unallocated area is discontinuous in frequency domain (divided in two parts by the allocated area – two sided), starts with PRB 0 and ends with PRB $N_{RB} - 1$.

Table A.5.1.2-1: OP.2 FDD: Two sided dynamic OCNG FDD Pattern

Relative power level γ_{PRB} [dB]			PDSCH Data
Subframe			
0	5	1 – 4, 6 – 9	
Allocation			
0 – (First allocated PRB-1) and (Last allocated PRB+1) – ($N_{RB} - 1$)	0 – (First allocated PRB-1) and (Last allocated PRB+1) – ($N_{RB} - 1$)	0 – (First allocated PRB-1) and (Last allocated PRB+1) – ($N_{RB} - 1$)	
0	0	0	Note 1
<p>Note 1: These physical resource blocks are assigned to an arbitrary number of virtual UEs with one PDSCH per virtual UE; the data transmitted over the OCNG PDSCHs shall be uncorrelated pseudo random data, which is QPSK modulated. The parameter γ_{PRB} is used to scale the power of PDSCH.</p> <p>Note 2: If two or more transmit antennas with CRS are used in the test, the OCNG shall be transmitted to the virtual users by all the transmit antennas with CRS according to transmission mode 2. The parameter γ_{PRB} applies to each antenna port separately, so the transmit power is equal between all the transmit antennas with CRS used in the test. The antenna transmission modes are specified in section 7.1 in 3GPP TS 36.213.</p>			

A.5.1.3 OCNG FDD pattern 3: 49 RB OCNG allocation with MBSFN in 10 MHz

Table A.5.1.3-1: OP.3 FDD: OCNG FDD Pattern 3

Allocation n_{PRB}	Relative power level γ_{PRB} [dB]				PDSCH Data	PMCH Data
	Subframe					
	0	5	4, 9	1 – 3, 6 – 8		
1 – 49	0	0 (Allocation: all empty PRB-s)	0	N/A	Note 1	N/A
0 – 49	N/A	N/A	N/A	0	N/A	Note 2
<p>Note 1: These physical resource blocks are assigned to an arbitrary number of virtual UEs with one PDSCH per virtual UE; the data transmitted over the OCNG PDSCHs shall be uncorrelated pseudo random data, which is QPSK modulated. The parameter γ_{PRB} is used to scale the power of PDSCH.</p> <p>Note 2: Each physical resource block (PRB) is assigned to MBSFN transmission. The data in each PRB shall be uncorrelated with data in other PRBs over the period of any measurement. The MBSFN data shall be QPSK modulated. PMCH subframes shall contain cell-specific Reference Signals only in the first symbol of the first time slot. The parameter γ_{PRB} is used to scale the power of PMCH.</p> <p>Note 3: If two or more transmit antennas are used in the test, the OCNG shall be transmitted to the virtual users by all the transmit antennas according to transmission mode 2. The transmit power shall be equally split between all the transmit antennas used in the test. The antenna transmission modes are specified in section 7.1 in 3GPP TS 36.213.</p> <p>N/A: Not Applicable</p>						

A.5.1.4 OCNG FDD pattern 4: One sided dynamic OCNG FDD pattern for MBMS transmission

This OCNG Pattern fills with OCNG all empty PRB-s (PRB-s with no allocation of data or system information) of the DL sub-frames, when the unallocated area is continuous in frequency domain (one sided) and MBMS performance is tested.

Table A.5.1.4-1: OP.4 FDD: One sided dynamic OCNG FDD Pattern for MBMS transmission

Allocation n_{PRB}	Relative power level γ_{PRB} [dB]			PDSCH Data	PMCH Data
	Subframe				
	0, 4, 9	5	1 – 3, 6 – 8		
First unallocated PRB – Last unallocated PRB	0	0 (Allocation: all empty PRB-s)	N/A	Note 1	N/A
First unallocated PRB – Last unallocated PRB	N/A	N/A	N/A	N/A	Note 2
<p>Note 1: These physical resource blocks are assigned to an arbitrary number of virtual UEs with one PDSCH per virtual UE; the data transmitted over the OCNG PDSCHs shall be uncorrelated pseudo random data, which is QPSK modulated. The parameter γ_{PRB} is used to scale the power of PDSCH.</p> <p>Note 2: Each physical resource block (PRB) is assigned to MBSFN transmission. The data in each PRB shall be uncorrelated with data in other PRBs over the period of any measurement. The MBSFN data shall be QPSK modulated. PMCH subframes shall contain cell-specific Reference Signals only in the first symbol of the first time slot. The parameter γ_{PRB} is used to scale the power of PMCH.</p> <p>Note 3: If two or more transmit antennas are used in the test, the OCNG shall be transmitted to the virtual users by all the transmit antennas according to transmission mode 2. The transmit power shall be equally split between all the transmit antennas used in the test. The antenna transmission modes are specified in section 7.1 in 3GPP TS 36.213.</p> <p>N/A: Not Applicable</p>					

A.5.1.5 OCNG FDD pattern 5: One sided dynamic 16QAM modulated OCNG FDD pattern

This OCNG Pattern fills with OCNG all empty PRB-s (PRB-s with no allocation of data or system information) of DL sub-frames, when the unallocated area is continuous in the frequency domain (one sided).

Table A.5.1.5-1: OP.5 FDD: One sided dynamic 16QAM modulated OCNG FDD Pattern

Relative power level γ_{PRB} [dB]			PDSCH Data
Subframe			
0	5	1 – 4, 6 – 9	
Allocation			
First unallocated PRB – Last unallocated PRB	First unallocated PRB – Last unallocated PRB	First unallocated PRB – Last unallocated PRB	
0	0	0	Note 1
<p>Note 1: These physical resource blocks are assigned to an arbitrary number of virtual UEs with one PDSCH per virtual UE; the data transmitted over the OCNG PDSCHs shall be uncorrelated pseudo random data, which is 16QAM modulated. The parameter γ_{PRB} is used to scale the power of PDSCH.</p> <p>Note 2: If two or more transmit antennas with CRS are used in the test, the OCNG shall be transmitted to the virtual users by all the transmit antennas with CRS according to transmission mode 3 (Large Delay CDD). The parameter γ_{PRB} applies to each antenna port separately, so the transmit power is equal between all the transmit antennas with CRS used in the test. The antenna transmission modes are specified in section 7.1 in 3GPP TS 36.213.</p>			

A.5.1.6 OCNG FDD pattern 6: dynamic OCNG FDD pattern when user data is in 2 non-contiguous blocks

This OCNG Pattern fills with OCNG all empty PRB-s (PRB-s with no allocation of data or system information) of the DL sub-frames, when the unallocated area is discontinuous in frequency domain (divided in two parts by the first allocated block). The second allocated block ends with PRB $N_{RB} - 1$.

Table A.5.1.6-1: OP.6 FDD: OCNG FDD Pattern when user data is in 2 non-contiguous blocks

Relative power level γ_{PRB} [dB]			PDSCH Data
Subframe			
0	5	1 – 4, 6 – 9	
Allocation			
0 – (First allocated PRB of first block -1) and (Last allocated PRB of first block +1) – (First allocated PRB of second block -1)	0 – (First allocated PRB of first block -1) and (Last allocated PRB of first block +1) – (First allocated PRB of second block -1)	0 – (First allocated PRB of first block -1) and (Last allocated PRB of first block +1) – (First allocated PRB of second block -1)	
0	0	0	Note 1
<p>Note 1: These physical resource blocks are assigned to an arbitrary number of virtual UEs with one PDSCH per virtual UE; the data transmitted over the OCNG PDSCHs shall be uncorrelated pseudo random data, which is QPSK modulated. The parameter γ_{PRB} is used to scale the power of PDSCH.</p> <p>Note 2: If two or more transmit antennas with CRS are used in the test, the OCNG shall be transmitted to the virtual users by all the transmit antennas with CRS according to transmission mode 2. The parameter γ_{PRB} applies to each antenna port separately, so the transmit power is equal between all the transmit antennas with CRS used in the test. The antenna transmission modes are specified in section 7.1 in 3GPP TS 36.213.</p>			

A.5.1.7 OCNG FDD pattern 7: dynamic OCNG FDD pattern when user data is in multiple non-contiguous blocks

This OCNG Pattern fills with OCNG all empty PRB-s (PRB-s with no allocation of data, EPDCCH or system information) of the DL sub-frames, when the unallocated area is discontinuous in frequency domain (divided in

multiple parts by the M allocated blocks for data transmission). The m -th allocated block starts with PRB $N_{Start,m}$ and ends with PRB $N_{End,m} - 1$, where $m = 1, \dots, M$. The system bandwidth starts with PRB 0 and ends with $N_{RB} - 1$.

Table A.5.1.7-1: OP.7 FDD: OCNG FDD Pattern when user data is in multiple non-contiguous blocks

Relative power level γ_{PRB} [dB]			PDSCH Data
Subframe			
0	5	1 – 4, 6 – 9	
Allocation			
0 – (PRB $N_{Start,1} - 1$) ... (PRB $N_{End,(m-1)} - 1$) – (PRB $N_{Start,m} - 1$) ... (PRB $N_{End,M} - 1$) – (PRB $N_{RB} - 1$)	0 – (PRB $N_{Start,1} - 1$) ... (PRB $N_{End,(m-1)} - 1$) – (PRB $N_{Start,m} - 1$) ... (PRB $N_{End,M} - 1$) – (PRB $N_{RB} - 1$)	0 – (PRB $N_{Start,1} - 1$) ... (PRB $N_{End,(m-1)} - 1$) – (PRB $N_{Start,m} - 1$) ... (PRB $N_{End,M} - 1$) – (PRB $N_{RB} - 1$)	
0	0	0	Note 1
<p>Note 1: These physical resource blocks are assigned to an arbitrary number of virtual UEs with one PDSCH per virtual UE; the data transmitted over the OCNG PDSCHs shall be uncorrelated pseudo random data, which is QPSK modulated. The parameter γ_{PRB} is used to scale the power of PDSCH.</p> <p>Note 2: If two or more transmit antennas with CRS are used in the test, the OCNG shall be transmitted to the virtual users by all the transmit antennas with CRS according to transmission mode 2. The parameter γ_{PRB} applies to each antenna port separately, so the transmit power is equal between all the transmit antennas with CRS used in the test. The antenna transmission modes are specified in section 7.1 in 3GPP TS 36.213.</p>			

A.5.1.8 OCNG FDD pattern 8: Dynamic OCNG FDD pattern for TM10 transmission

This OCNG Pattern fills with OCNG all empty PRB-s (PRB-s with no allocation of data or system information) of the DL sub-frames, when the unallocated area is discontinuous in frequency domain where there are M unallocated PRB blocks labled from 1-st block to M -th block ($M > 1$) and the m -th block starts with PRB $N_{Start,m}$ and end with PRB $N_{End,m}$, or

when the unallocated area is continuous in frequency domain where $M = 1$ (one sided). The system bandwidth starts with PRB 0 and ends with $N_{RB} - 1$. $N_{End,M}$ should be equal to or less than $N_{RB} - 1$.

Table A.5.1.8-1: OP.8 FDD: Dynamic OCNG FDD Pattern

Relative power level γ_{PRB} [dB]			PDSCH Data
Subframe			
0	5	1 – 4, 6 – 9	
Allocation			
1-st unallocated PRB (PRB $N_{Start,1}$ ~ PRB $N_{End,1}$) ... m -th unallocated PRB (PRB $N_{Start,m}$ ~ PRB $N_{End,m}$) ... M -th unallocated PRB (PRB $N_{Start,M}$ ~ PRB $N_{End,M}$)	1-st unallocated PRB (PRB $N_{Start,1}$ ~ PRB $N_{End,1}$) ... m -th unallocated PRB (PRB $N_{Start,m}$ ~ PRB $N_{End,m}$) ... M -th unallocated PRB (PRB $N_{Start,M}$ ~ PRB $N_{End,M}$)	1-st unallocated PRB (PRB $N_{Start,1}$ ~ PRB $N_{End,1}$) ... m -th unallocated PRB (PRB $N_{Start,m}$ ~ PRB $N_{End,m}$) ... M -th unallocated PRB (PRB $N_{Start,M}$ ~ PRB $N_{End,M}$)	
0	0	0	Note 1,2,3
<p>Note 1: These physical resource blocks are assigned to an arbitrary number of virtual UEs with one PDSCH per virtual UE; the data transmitted over the OCNG PDSCHs shall be uncorrelated pseudo random data, which is 16QAM modulated. The parameter γ_{PRB} is used to scale the power of PDSCH.</p> <p>Note 2: The OCNG shall be transmitted to the virtual users by all the transmit antennas according to transmission mode10. The the transmit power is equal between all the transmit antennas used in the test. The antenna transmission modes are specified in section 7.1 in 3GPP TS 36.213.</p> <p>Note 3: The detailed test set-up for TM10 transmission i.e PMI configuration is specified to each test case.</p>			

A.5.2 OCNG Patterns for TDD

The following OCNG patterns are used for modelling allocations to virtual UEs (which are not under test). The OCNG pattern for each sub frame specifies the allocations that shall be filled with OCNG, and furthermore, the relative power level of each such allocation.

In each test case the OCNG is expressed by parameters OCNG_RA and OCNG_RB which together with a relative power level (γ) specifies the PDSCH EPRE-to-RS EPRE ratios in OFDM symbols with and without reference symbols, respectively. The relative power, which is used for modelling boosting per virtual UE allocation, is expressed by:

$$\gamma_i = PDSCH_i_RA / OCNG_RA = PDSCH_i_RB / OCNG_RB,$$

where γ_i denotes the relative power level of the i :th virtual UE. The parameter settings of OCNG_RA, OCNG_RB, and the set of relative power levels γ are chosen such that when also taking allocations to the UE under test into account, as given by a PDSCH reference channel, a transmitted power spectral density that is constant on an OFDM symbol basis is targeted.

Moreover the OCNG pattern is accompanied by a PCFICH/PDCCH/PHICH reference channel which specifies the control region. For any aggregation and PHICH allocation, the PDCCH and any unused PHICH groups are padded with resource element groups with a power level given respectively by PDCCH_RA/RB and PHICH_RA/RB as specified in the test case such that a total power spectral density in the control region that is constant on an OFDM symbol basis is targeted.

A.5.2.1 OCNG TDD pattern 1: One sided dynamic OCNG TDD pattern

This OCNG Pattern fills with OCNG all empty PRB-s (PRB-s with no allocation of data or system information) of the subframes available for DL transmission (depending on TDD UL/DL configuration), when the unallocated area is continuous in frequency domain (one sided).

Table A.5.2.1-1: OP.1 TDD: One sided dynamic OCNG TDD Pattern

Relative power level γ_{PRB} [dB]				PDSCH Data
Subframe (only if available for DL)				
0	5	3, 4, 7, 8, 9 and 6 (as normal subframe) <small>Note 2</small>	1 and 6 (as special subframe) <small>Note 2</small>	
Allocation				
First unallocated PRB –	First unallocated PRB –	First unallocated PRB –	First unallocated PRB –	
Last unallocated PRB	Last unallocated PRB	Last unallocated PRB	Last unallocated PRB	
0	0	0	0	Note 1
<p>Note 1: These physical resource blocks are assigned to an arbitrary number of virtual UEs with one PDSCH per virtual UE; the data transmitted over the OCNG PDSCHs shall be uncorrelated pseudo random data, which is QPSK modulated. The parameter γ_{PRB} is used to scale the power of PDSCH.</p> <p>Note 2: Subframes available for DL transmission depends on the Uplink-Downlink configuration in Table 4.2-2 in 3GPP TS 36.211</p> <p>Note 3: If two or more transmit antennas with CRS are used in the test, the OCNG shall be transmitted to the virtual users by all the transmit antennas with CRS according to transmission mode 2. The parameter γ_{PRB} applies to each antenna port separately, so the transmit power is equal between all the transmit antennas with CRS used in the test. The antenna transmission modes are specified in section 7.1 in 3GPP TS 36.213.</p>				

A.5.2.2 OCNG TDD pattern 2: Two sided dynamic OCNG TDD pattern

This OCNG Pattern fills with OCNG all empty PRB-s (PRB-s with no allocation of data or system information) of the subframes available for DL transmission (depending on TDD UL/DL configuration), when the unallocated area is discontinuous in frequency domain (divided in two parts by the allocated area – two sided), starts with PRB 0 and ends with PRB $N_{RB} - 1$.

Table A.5.2.2-1: OP.2 TDD: Two sided dynamic OCNG TDD Pattern

Relative power level γ_{PRB} [dB]				PDSCH Data
Subframe (only if available for DL)				
0	5	3, 4, 6, 7, 8, 9 (6 as normal subframe) <small>Note 2</small>	1,6 (6 as special subframe) <small>Note 2</small>	
Allocation				
0 – (First allocated PRB-1) and (Last allocated PRB+1) – ($N_{RB} - 1$)	0 – (First allocated PRB-1) and (Last allocated PRB+1) – ($N_{RB} - 1$)	0 – (First allocated PRB-1) and (Last allocated PRB+1) – ($N_{RB} - 1$)	0 – (First allocated PRB-1) and (Last allocated PRB+1) – ($N_{RB} - 1$)	
0	0	0	0	
<p>Note 1: These physical resource blocks are assigned to an arbitrary number of virtual UEs with one PDSCH per virtual UE; the data transmitted over the OCNG PDSCHs shall be uncorrelated pseudo random data, which is QPSK modulated. The parameter γ_{PRB} is used to scale the power of PDSCH.</p> <p>Note 2: Subframes available for DL transmission depends on the Uplink-Downlink configuration in Table 4.2-2 in 3GPP TS 36.211</p> <p>Note 3: If two or more transmit antennas with CRS are used in the test, the OCNG shall be transmitted to the virtual users by all the transmit antennas with CRS according to transmission mode 2. The parameter γ_{PRB} applies to each antenna port separately, so the transmit power is equal between all the transmit antennas with CRS used in the test. The antenna transmission modes are specified in section 7.1 in 3GPP TS 36.213.</p>				

A.5.2.3 OCNG TDD pattern 3: 49 RB OCNG allocation with MBSFN in 10 MHz

Table A.5.2.3-1: OP.3 TDD: OCNG TDD Pattern 3 for 5ms downlink-to-uplink switch-point periodicity

Allocation n_{PRB}	Relative power level γ_{PRB} [dB]				PDSCH Data	PMCH Data
	Subframe					
	0	5	4, 9 ^{Note 2}	1, 6		
1 – 49	0	0 (Allocation: all empty PRB-s)	N/A	0	Note 1	N/A
0 – 49	N/A	N/A	0	N/A	N/A	Note 3
<p>Note 1: These physical resource blocks are assigned to an arbitrary number of virtual UEs with one PDSCH per virtual UE; the data transmitted over the OCNG PDSCHs shall be uncorrelated pseudo random data, which is QPSK modulated. The parameter γ_{PRB} is used to scale the power of PDSCH.</p> <p>Note 2: Subframes available for DL transmission depends on the Uplink-Downlink configuration in Table 4.2-2 in 3GPP TS 36.211.</p> <p>Note 3: Each physical resource block (PRB) is assigned to MBSFN transmission. The data in each PRB shall be uncorrelated with data in other PRBs over the period of any measurement. The MBSFN data shall be QPSK modulated. PMCH symbols shall not contain cell-specific Reference Signals.</p> <p>Note 4: If two or more transmit antennas are used in the test, the OCNG shall be transmitted to the virtual users by all the transmit antennas according to transmission mode 2. The transmit power shall be equally split between all the transmit antennas used in the test. The antenna transmission modes are specified in section 7.1 in 3GPP TS 36.213.</p>						
N/A Not Applicable						

A.5.2.4 OCNG TDD pattern 4: One sided dynamic OCNG TDD pattern for MBMS transmission

This OCNG Pattern fills with OCNG all empty PRB-s (PRB-s with no allocation of data or system information) of the DL sub-frames, when the unallocated area is continuous in frequency domain (one sided) and MBMS performance is tested.

Table A.5.2.4-1: OP.4 TDD: One sided dynamic OCNG TDD Pattern for MBMS transmission

Allocation n_{PRB}	Relative power level γ_{PRB} [dB]				PDSCH Data	PMCH Data
	Subframe (only for DL)					
	0 and 6 (as normal subframe)	1 (as special subframe)	5	3, 4, 7 – 9		

First unallocated PRB – Last unallocated PRB	0	0 (Allocation: all empty PRB-s of DwPTS)	0 (Allocation: all empty PRB-s)	N/A	Note 1	N/A
First unallocated PRB – Last unallocated PRB	N/A	N/A	N/A	N/A	N/A	Note2
<p>Note 1: These physical resource blocks are assigned to an arbitrary number of virtual UEs with one PDSCH per virtual UE; the data transmitted over the OCNG PDSCHs shall be uncorrelated pseudo random data, which is QPSK modulated. The parameter γ_{PRB} is used to scale the power of PDSCH.</p> <p>Note 2: Each physical resource block (PRB) is assigned to MBSFN transmission. The data in each PRB shall be uncorrelated with data in other PRBs over the period of any measurement. The MBSFN data shall be QPSK modulated. PMCH symbols shall not contain cell-specific Reference Signals.</p> <p>Note 3: If two or more transmit antennas are used in the test, the OCNG shall be transmitted to the virtual users by all the transmit antennas according to transmission mode 2. The transmit power shall be equally split between all the transmit antennas used in the test. The antenna transmission modes are specified in section 7.1 in 3GPP TS 36.213.</p>						
N/A	Not Applicable					

A.5.2.5 OCNG TDD pattern 5: One sided dynamic 16QAM modulated OCNG TDD pattern

This OCNG Pattern fills with OCNG all empty PRB-s (PRB-s with no allocation of data or system information) of the sub-frames available for DL transmission (depending on TDD UL/DL configuration), when the unallocated area is continuous in frequency domain (one sided).

Table A.5.2.5-1: OP.5 TDD: One sided dynamic 16QAM modulated OCNG TDD Pattern

Relative power level γ_{PRB} [dB]				PDSCH Data
Subframe (only if available for DL)				
0	5	3, 4, 7, 8, 9 and 6 (as normal subframe) ^{Note 2}	1 and 6 (as special subframe) ^{Note 2}	
Allocation				
First unallocated PRB – Last unallocated PRB	First unallocated PRB – Last unallocated PRB	First unallocated PRB – Last unallocated PRB	First unallocated PRB – Last unallocated PRB	
0	0	0	0	Note 1
<p>Note 1: These physical resource blocks are assigned to an arbitrary number of virtual UEs with one PDSCH per virtual UE; the data transmitted over the OCNG PDSCHs shall be uncorrelated pseudo random data, which is 16QAM modulated. The parameter γ_{PRB} is used to scale the power of PDSCH.</p> <p>Note 2: Subframes available for DL transmission depends on the Uplink-Downlink configuration in Table 4.2-2 in 3GPP TS 36.211</p> <p>Note 3: If two or more transmit antennas with CRS are used in the test, the OCNG shall be transmitted to the virtual users by all the transmit antennas with CRS according to transmission mode 3 (Large Delay CDD). The parameter γ_{PRB} applies to each antenna port separately, so the transmit power is equal between all the transmit antennas with CRS used in the test. The antenna transmission modes are specified in section 7.1 in 3GPP TS 36.213.</p>				

A.5.2.6 OCNG TDD pattern 6: dynamic OCNG TDD pattern when user data is in 2 non-contiguous blocks

This OCNG Pattern fills with OCNG all empty PRB-s (PRB-s with no allocation of data or system information) of the subframes available for DL transmission (depending on TDD UL/DL configuration), when the unallocated area is discontinuous in frequency domain (divided in two parts by the first allocated block). The second allocated block ends with PRB $N_{RB} - 1$.

Table A.5.2.6-1: OP.6 TDD: OCNG TDD Pattern when user data is in 2 non-contiguous blocks

Relative power level γ_{PRB} [dB]				PDSCH Data
Subframe (only if available for DL)				
0	5	3, 4, 6, 7, 8, 9 (6 as normal subframe) <small>Note 2</small>	1,6 (6 as special subframe) <small>Note 2</small>	
Allocation				
0 – (First allocated PRB of first block -1) and (Last allocated PRB of first block +1) – (First allocated PRB of second block -1)	0 – (First allocated PRB of first block -1) and (Last allocated PRB of first block +1) – (First allocated PRB of second block -1)	0 – (First allocated PRB of first block -1) and (Last allocated PRB of first block +1) – (First allocated PRB of second block -1)	0 – (First allocated PRB of first block -1) and (Last allocated PRB of first block +1) – (First allocated PRB of second block -1)	
0	0	0	0	Note 1
<p>Note 1: These physical resource blocks are assigned to an arbitrary number of virtual UEs with one PDSCH per virtual UE; the data transmitted over the OCNG PDSCHs shall be uncorrelated pseudo random data, which is QPSK modulated. The parameter γ_{PRB} is used to scale the power of PDSCH.</p> <p>Note 2: Subframes available for DL transmission depends on the Uplink-Downlink configuration in Table 4.2-2 in 3GPP TS 36.211</p> <p>Note 3: If two or more transmit antennas with CRS are used in the test, the OCNG shall be transmitted to the virtual users by all the transmit antennas with CRS according to transmission mode 2. The parameter γ_{PRB} applies to each antenna port separately, so the transmit power is equal between all the transmit antennas with CRS used in the test. The antenna transmission modes are specified in section 7.1 in 3GPP TS 36.213.</p>				

A.5.2.7 OCNG TDD pattern 7: dynamic OCNG TDD pattern when user data is in multiple non-contiguous blocks

This OCNG Pattern fills with OCNG all empty PRB-s (PRB-s with no allocation of data, EPDCCH or system information) of the DL sub-frames, when the unallocated area is discontinuous in frequency domain (divided in multiple parts by the M allocated blocks for data transmission). The m -th allocated block starts with RPB $N_{Start,m}$ and ends with PRB $N_{End,m} - 1$, where $m = 1, \dots, M$. The system bandwidth starts with RPB 0 and ends with $N_{RB} - 1$.

Table A.5.2.7-1: OP.7 TDD: OCNG TDD Pattern when user data is in multiple non-contiguous blocks

Relative power level γ_{PRB} [dB]				PDSCH Data
Subframe (only if available for DL)				
0	5	3, 4, 6, 7, 8, 9 (6 as normal subframe) <small>Note 2</small>	1,6 (6 as special subframe) <small>Note 2</small>	
Allocation				
0 – (PRB $N_{Start,1} - 1$) ... (PRB $N_{End,(m-1)} - 1$) – (PRB $N_{Start,m} - 1$) ... (PRB $N_{End,M} - 1$) – (PRB	0 – (PRB $N_{Start,1} - 1$) ... (PRB $N_{End,(m-1)} - 1$) – (PRB $N_{Start,m} - 1$) ... (PRB $N_{End,M} - 1$) – (PRB	0 – (PRB $N_{Start,1} - 1$) ... (PRB $N_{End,(m-1)} - 1$) – (PRB $N_{Start,m} - 1$) ... (PRB $N_{End,M} - 1$) – (PRB	0 – (PRB $N_{Start,1} - 1$) ... (PRB $N_{End,(m-1)} - 1$) – (PRB $N_{Start,m} - 1$) ... (PRB $N_{End,M} - 1$) – (PRB	

$N_{RB} - 1$	$N_{RB} - 1$	$N_{RB} - 1$	$N_{RB} - 1$	
0	0	0	0	Note 1
<p>Note 1: These physical resource blocks are assigned to an arbitrary number of virtual UEs with one PDSCH per virtual UE; the data transmitted over the OCNG PDSCHs shall be uncorrelated pseudo random data, which is QPSK modulated. The parameter γ_{PRB} is used to scale the power of PDSCH.</p> <p>Note 2: Subframes available for DL transmission depends on the Uplink-Downlink configuration in Table 4.2-2 in 3GPP TS 36.211</p> <p>Note 3: If two or more transmit antennas with CRS are used in the test, the OCNG shall be transmitted to the virtual users by all the transmit antennas with CRS according to transmission mode 2. The parameter γ_{PRB} applies to each antenna port separately, so the transmit power is equal between all the transmit antennas with CRS used in the test. The antenna transmission modes are specified in section 7.1 in 3GPP TS 36.213.</p>				

A.5.2.8 OCNG TDD pattern 8: Dynamic OCNG TDD pattern for TM10 transmission

This OCNG Pattern fills with OCNG all empty PRB-s (PRB-s with no allocation of data or system information) of the DL sub-frames, when the unallocated area is discontinuous in frequency domain where there are M unallocated PRB blocks labled from 1-st block to M -th block ($M > 1$) and the m -th block starts with PRB $N_{Start,m}$ and end with PRB $N_{End,m}$, or when the unallocated area is continuous in frequency domain where $M = 1$ (one sided). The system bandwidth starts with RPB 0 and ends with $N_{RB} - 1$. $N_{End,M}$ should be equal to or less than $N_{RB} - 1$.

Table A.5.2.8-1: OP.8 TDD: Dynamic OCNG TDD Pattern

Relative power level γ_{PRB} [dB]			PDSCH Data
Subframe			
0	5	1 – 4, 6 – 9	
Allocation			
1-st unallocated PRB (PRB $N_{Start,1}$ ~ PRB $N_{End,1}$) ... m -th unallocated PRB (PRB $N_{Start,m}$ ~ PRB $N_{End,m}$) ... M -th unallocated PRB (PRB $N_{Start,M}$ ~ PRB $N_{End,M}$)	1-st unallocated PRB (PRB $N_{Start,1}$ ~ PRB $N_{End,1}$) ... m -th unallocated PRB (PRB $N_{Start,m}$ ~ PRB $N_{End,m}$) ... M -th unallocated PRB (PRB $N_{Start,M}$ ~ PRB $N_{End,M}$)	1-st unallocated PRB (PRB $N_{Start,1}$ ~ PRB $N_{End,1}$) ... m -th unallocated PRB (PRB $N_{Start,m}$ ~ PRB $N_{End,m}$) ... M -th unallocated PRB (PRB $N_{Start,M}$ ~ PRB $N_{End,M}$)	
0	0	0	Note 1,2,3
<p>Note 1: These physical resource blocks are assigned to an arbitrary number of virtual UEs with one PDSCH per virtual UE; the data transmitted over the OCNG PDSCHs shall be uncorrelated pseudo random data, which is 16QAM modulated. The parameter γ_{PRB} is used to scale the power of PDSCH.</p> <p>Note 2: The OCNG shall be transmitted to the virtual users by all the transmit antennas according to transmission mode10. The the transmit power is equal between all the transmit antennas used in the test. The antenna transmission modes are specified in section 7.1 in 3GPP TS 36.213.</p> <p>Note 3: The detailed test set-up for TM10 transmission i.e PMI configuration is specified to each test case.</p>			

A.6 Sidelink reference measurement channels

A.6.1 General

The algorithm for determining the payload size A is as follows; given a desired coding rate R and radio block allocation N_{RB}

1. Calculate the number of channel bits N_{ch} that can be transmitted during the first transmission of a given sub-frame.
2. Find A such that the resulting coding rate is as close to R as possible, that is,

$$\min |R - (A + 24 * (N_{CB} + 1)) / N_{ch}|, \text{ where } N_{CB} = \begin{cases} 0, & \text{if } C = 1 \\ C, & \text{if } C > 1 \end{cases}$$

subject to

- a) A is a valid TB size according to section 7.1.7 of TS 36.213 [6] assuming an allocation of N_{RB} resource blocks.
 - b) C is the number of Code Blocks calculated according to section 5.1.2 of TS 36.212 [5].
3. If there is more than one A that minimizes the equation above, then the larger value is chosen per default and the chosen code rate should not exceed 0.93.

A.6.1.1 Overview of ProSe reference measurement channels

In Table A.6.1.1-1 are listed the ProSe reference measurement channels specified in annexes A.6.2 to A.6.6 of this release of TS 36.101. This table is informative and serves only to a better overview. The reference for the concrete reference measurement channels and corresponding implementation's parameters as to be used for requirements are annexes A.6.2 to A.6.6 as appropriate.

Table A.6.1.1-1: Overview of ProSe reference measurement channels

Table	Name	BW	Mod	RB	UE Categ	Notes
Table A.6.2-1	-	5	QPSK	2	≥ 1	
Table A.6.2-1	-	10	QPSK	2	≥ 1	
Table A.6.2-1	-	15	QPSK	2	≥ 1	
Table A.6.2-1	-	20	QPSK	2	≥ 1	
Table A.6.2-2	-	5	QPSK	25	≥ 1	
Table A.6.2-2	-	10	QPSK	50	≥ 1	
Table A.6.2-3	-	5	16QAM	25	2-8	
Table A.6.2-3	-	10	16QAM	50	2-8	
Table A.6.2-4	-	5	16QAM	25	1	
Table A.6.2-4	-	10	16QAM	50	1	
Table A.6.3-1	D.1 FDD / D.1 TDD	5	QPSK	2	≥ 1	
Table A.6.3-1	D.1 FDD / D.1 TDD	10	QPSK	2	≥ 1	
Table A.6.3-1	D.1 FDD / D.1 TDD	15	QPSK	2	≥ 1	
Table A.6.3-1	D.1 FDD / D.1 TDD	20	QPSK	2	≥ 1	
Table A.6.4-1	CC.1 FDD	5	QPSK	1	-	
Table A.6.4-1	CC.2 FDD	10	QPSK	1	-	
Table A.6.4-1	CC.3 FDD	5	QPSK	1	-	
Table A.6.4-1	CC.4 FDD	10	QPSK	1	-	
Table A.6.4-1	CC.5 FDD	5	QPSK	1	-	
Table A.6.4-1	CC.6 FDD	10	QPSK	1	-	
Table A.6.5-1	CD.1 FDD	5/10	QPSK	10	-	
Table A.6.5-1	CD.2 FDD	5/10	16QAM	10	-	
Table A.6.5-1	CD.3 FDD	5	16QAM	25	-	
Table A.6.5-1	CD.4 FDD	10	16QAM	50	-	
Table A.6.5-1	CD.5 FDD	5/10	QPSK	2	-	
Table A.6.5-2	CD.6 FDD	5	16QAM	25	-	
Table A.6.5-2	CD.7 FDD	10	16QAM	50	-	
Table A.6.6-1	CP.1 FDD	5/10	QPSK	6	-	

A.6.2 Reference measurement channel for receiver characteristics

For ProSe Direct Discovery, Table A.6.2-1 is applicable for measurements on the Receiver Characteristics (clause 7) including the requirements of subclause 7.4D (Maximum input level).

For ProSe Direct Communication, Table A.6.2-2 is applicable for measurements on the Receiver Characteristics (clause 7) with the exception of subclause 7.4D (Maximum input level). Tables A.6.2-3, A.6.2-4, are applicable for subclause 7.4D (Maximum input level).

Table A.6.2-1: Fixed Reference measurement channel for ProSe Direct Discovery receiver requirements and maximum input level

Parameter	Unit	Value					
		1.4	3	5	10	15	20
Channel bandwidth	MHz						
Allocated resource blocks				2	2	2	2
Subcarriers per resource block				12	12	12	12
Allocated subframes per Discovery period				1	1	1	1
DFT-OFDM Symbols per subframe (see note)				11	11	11	11
Modulation				QPSK	QPSK	QPSK	QPSK
Transport Block Size				232	232	232	232
Transport block CRC	Bits			24	24	24	24
Maximum number of HARQ transmissions				1	1	1	1
Binary Channel Bits (see note)	Bits			528	528	528	528
Max. Throughput averaged over 1 Discovery period of 320ms	kbps			0.725	0.725	0.725	0.725
UE Category				≥ 1	≥ 1	≥ 1	≥ 1

NOTE 1: PSDCH transmissions are rate-matched for 12 DFT-OFDM symbols per subframe, and the last symbol shall be punctured as per TS 36.211.

NOTE 2: Throughput is 232 bits per Discovery period. The discovery period is configured as 320ms in the test.

Table A.6.2-2: Fixed Reference measurement channel for ProSe Direct Communication receiver requirements

Parameter	Unit	Value					
		1.4	3	5	10	15	20
Channel bandwidth	MHz						
Allocated resource blocks				25	50		
Subcarriers per resource block				12	12		
Packets per SA period				1	1		
Modulation				QPSK	QPSK		
Transport Block Size				2216	4392		
Transport block CRC	Bits			24	24		
Maximum number of HARQ transmissions				4	4		
Binary Channel Bits	Bits			7200	14400		
Max. Throughput averaged over 1 SA period of 40ms	kbps			55.4	109.8		
UE Category				≥ 1	≥ 1		

NOTE 1: For PSSCH transmission, the last symbol shall be punctured as per TS 36.211.

NOTE 2: Throughput (in kbps) will depend on SA period configuration

Table A.6.2-3: Fixed Reference measurement channel for ProSe Direct Communication for maximum input power for UE categories 2-8

Parameter	Unit	Value					
		1.4	3	5	10	15	20
Channel bandwidth	MHz						
Allocated resource blocks				25	50		
Subcarriers per resource block				12	12		
Packets per SA period				1	1		
Modulation				16QAM	16QAM		
Transport Block Size				9912	18336		
Transport block CRC	Bits			24	24		
Maximum number of HARQ transmissions				4	4		
Binary Channel Bits	Bits			14400	28800		
Max. Throughput averaged over 1 SA period of 40ms	kbps			247.8	458.4		

NOTE 1: For PSSCH transmission, the last symbol shall be punctured as per TS 36.211.

NOTE 2: If more than one Code Block is present, an additional CRC sequence of L = 24 Bits is attached to each Code Block (otherwise L = 0 Bit).

NOTE 3: Throughput (in kbps) will depend on SA period configuration

Table A.6.2-4: Fixed Reference measurement channel for ProSe Direct Communication for maximum input power for UE category 1

Parameter	Unit	Value					
		1.4	3	5	10	15	20
Channel bandwidth	MHz	1.4	3	5	10	15	20
Allocated resource blocks				25	24		
Subcarriers per resource block				12	12		
Packets per SA period				1	1		
Modulation				16QAM	16QAM		
Transport Block Size				9912	10296		
Transport block CRC	Bits			24	24		
Maximum number of HARQ transmissions				4	4		
Binary Channel Bits	Bits			14400	13824		
Max. Throughput averaged over 1 SA period of 40ms	kbps			247.8	257.4		
NOTE 1: For PSSCH transmission, the last symbol shall be punctured as per TS 36.211.							
NOTE 2: If more than one Code Block is present, an additional CRC sequence of L = 24 Bits is attached to each Code Block (otherwise L = 0 Bit).							
NOTE 3: Throughput (in kbps) will depend on SA period configuration							

A.6.3 Reference measurement channels for PSDCH performance requirements Table A.6.3-1: Fixed Reference measurement channel for PSDCH performance requirement

Parameter	Unit	Value					
		D.1 FDD / D.1 TDD					
Reference channel							
Channel bandwidth	MHz	1.4	3	5	10	15	20
Allocated resource blocks				2	2	2	2
Subcarriers per resource block				12	12	12	12
DFT-OFDM Symbols per subframe (NOTE 1)				11	11	11	11
Modulation				QPSK	QPSK	QPSK	QPSK
Transport Block Size				232	232	232	232
Transport block CRC	Bits			24	24	24	24
Binary Channel Bits (NOTE 1)	Bits			528	528	528	528
Max. Throughput averaged over 1 Discovery period of 320ms	kbps			0.725	0.725	0.725	0.725
UE Category				≥ 1	≥ 1	≥ 1	≥ 1
NOTE1: PSDCH transmissions are rate-matched for 12 DFT-OFDM symbols per subframe, and the last symbol shall be punctured as per TS 36.211.							

A.6.4 Reference measurement channels for PSCCH performance requirements

Table A.6.4-1: Fixed reference measurement channel for PSCCH performance requirement

Parameter		Unit	Value					
			CC.1 FDD	CC.2 FDD	CC.3 FDD	CC.4 FDD	CC.5 FDD	CC.6 FDD
Reference channel								
Channel bandwidth		MHz	5	10	5	10	5	10
Allocated resource blocks			1	1	1	1	1	1
Subcarriers per resource block			12	12	12	12	12	12
DFT-OFDM Symbols per subframe (see NOTE 1)			11	11	11	11	11	11
Modulation			QPSK	QPSK	QPSK	QPSK	QPSK	QPSK
Transport Block Size		Bits	41	43	41	43	41	43
Information bits	Frequency hopping flag		0	0	1	1	1	1
	RB assignment		Set as per PSSCH RB allocation specific in the test					
	Hopping bits		N/A	N/A	1 Type 2 Hopping	(1,1) Type 2 Hopping	0 Type 1 Hopping	(1,0) Type 1 Hopping
	Time resource pattern (I_{TRP})		8 (unless specified otherwise in the test) (NOTE 3)					
	Modulation and coding scheme		Set as the PSSCH MCS specified in the test					
	Timing advance indication		0 (unless specified otherwise in the test)					
	Group destination ID		As set by higher layers					
Transport block CRC		Bits	16	16	16	16	16	16
Maximum number of HARQ transmissions			2	2	2	2	2	2
Binary Channel Bits (see NOTE 1,2)		Bits	264	264	264	264	264	264
Max. Throughput averaged over one sc-period (bits/sc-period)			41	43	41	43	41	43
NOTE 1: PSCCH transmissions are rate-matched for 12 DFT-OFDM symbols per subframe, and the last symbol shall be punctured as per TS 36.211.								
NOTE 2: Binary channel bits per HARQ transmission.								
NOTE 3: For $N_{TRP} = 8$ (FDD) and $trpt-Subset = 010$, $I_{TRP} = 8$ corresponds to a time repetition pattern of (1,1,0,0,0,0,0,0) as per TS 36.213.								

A.6.5 Reference measurement channels for PSSCH performance requirements

Table A.6.5-1: Fixed reference measurement channel for PSSCH performance requirement

Parameter	Unit	Value				
		CD.1 FDD	CD.2 FDD	CD.3 FDD	CD.4 FDD	CD.5 FDD
Reference channel						
Channel bandwidth	MHz	5 / 10	5 / 10	5	10	5 / 10
Allocated resource blocks		10	10	25	50	2
Subcarriers per resource block		12	12	12	12	12
DFT-OFDM Symbols per subframe (see NOTE 1)		11	11	11	11	11
Modulation		QPSK	16QAM	16QAM	16QAM	QPSK
Transport Block Size		872	2536	6456	12960	328
Transport block CRC	Bits	24	24	24	24	24
Maximum number of HARQ transmissions		4	4	4	4	4
Binary Channel Bits (see NOTE 1,2)	Bits	2640	5280	13200	26400	528
Max. Throughput averaged over one sc-period (bits/sc-period)		872	2536	6456	12960	328
NOTE 1: PSSCH transmissions are rate-matched for 12 DFT-OFDM symbols per subframe, and the last symbol shall be punctured as per TS 36.211.						
NOTE 2: Binary channel bits per HARQ transmission.						
NOTE 3: If more than one Code Block is present, an additional CRC sequence of L = 24 Bits is attached to each Code Block (otherwise L = 0 Bit).						

Table A.6.5-2: Fixed reference measurement channel for PSSCH for maximum Sidelink processes test

Parameter	Unit	Value	
		CD.6 FDD	CD.7 FDD
Reference channel			
Channel bandwidth	MHz	5	10
Allocated resource blocks		25	50
Subcarriers per resource block		12	12
DFT-OFDM Symbols per subframe (see NOTE 1)		11	11
Modulation		16QAM	16QAM
Transport Block Size		15840	25456
Transport block CRC	Bits	24	24
Maximum number of HARQ transmissions		4	4
Binary Channel Bits (see NOTE 1,2)	Bits	13200	26400
Max. Throughput averaged over one sc-period (bits/sc-period)		15840	25456
NOTE 1: PSSCH transmissions are rate-matched for 12 DFT-OFDM symbols per subframe, and the last symbol shall be punctured as per TS 36.211.			
NOTE 2: Binary channel bits per HARQ transmission.			
NOTE 3: If more than one Code Block is present, an additional CRC sequence of L = 24 Bits is attached to each Code Block (otherwise L = 0 Bit).			

A.6.6 Reference measurement channels for PSBCH performance requirements

Table A.6.6-1: Fixed reference measurement channel for PSBCH performance requirement

Parameter	Unit	Value
Reference channel		CP.1 FDD
Channel bandwidth	MHz	5 / 10
Allocated resource blocks		6
Subcarriers per resource block		12
DFT-OFDM Symbols per subframe (see NOTE 1)		7
Modulation		QPSK
Transport Block Size		40
Transport block CRC	Bits	16
Maximum number of HARQ transmissions		1
Binary Channel Bits (see NOTE 1,2)	Bits	1008
Max. Throughput averaged over 40ms	kbps	1
NOTE 1: PSBCH transmissions are rate-matched for 8 DFT-OFDM symbols per subframe, and the last symbol shall be punctured as per TS 36.211.		
NOTE 2: Binary channel bits per HARQ transmission.		

A.7 Sidelink reference resource pool configurations

A.7.1 Reference resource pool configurations for ProSe Direct Discovery demodulation tests

A.7.1.1 FDD

Table A.7.1.1-1: ProSe Direct Discovery configuration for E-UTRA FDD (Configuration #1-FDD)

Information Element			Value	
discRxPool	cp-Len		Normal	
	discPeriod		rf32	
	numRetx		0	
	numRepetition		1	
	tf-ResourceConfig	prb-Num		12
		prb-Start		0
		prb-End		23
		offsetIndicator		160
		subframeBitmap		10000000 00000000 00000000 00000000 00000000
		txParameters		not present
	rxParameters		not present	
discTxPoolCommon			not present	
discTxPowerInfo			not present	
SL-SyncConfig			not present	
discInterFreqList			not present	

Table A.7.1.1-2: ProSe Direct Discovery configuration for E-UTRA FDD (Configuration #2-FDD)

Information Element		Value	
discRxPool(0)	cp-Len	Normal	
	discPeriod	rf32	
	numRetx	0	
	numRepetition	1	
	tf-ResourceConfig	prb-Num	12
		prb-Start	0
		prb-End	23
		offsetIndicator	150
		subframeBitmap	10000000 00000000 00000000 00000000 00000000
	txParameters	not present	
rxParameters	not present		
discRxPool(1)	cp-Len	Normal	
	discPeriod	rf32	
	numRetx	0	
	numRepetition	1	
	tf-ResourceConfig	prb-Num	12
		prb-Start	0
		prb-End	23
		offsetIndicator	170
		subframeBitmap	10000000 00000000 00000000 00000000 00000000
	txParameters	not present	
rxParameters	<i>tdd-Config</i> not present		
	<i>syncConfigIndex</i>	0	
<i>discTxPoolCommon</i>		not present	
<i>discTxPowerInfo</i>		not present	
<i>SL-SyncConfig(0)</i>	<i>syncCP-Len</i>	Normal	
	<i>syncOffsetIndicator</i>	0 (160 mod 40)	
	<i>slssid</i>	30	
	<i>txParameters</i>	not present	
	<i>rxParamsNCell</i>	<i>physCellId</i>	1
		<i>discSyncWindow</i>	w1
<i>discInterFreqList</i>		not present	

Table A.7.1.1-3: ProSe Direct Discovery configuration for E-UTRA FDD (Configuration #3-FDD)

Information Element			Value
discRxPool(iPool), iPool = 0...NPool-1	cp-Len		Normal
	discPeriod		rf32
	numRetx		3
	numRepetition		=2 if NPool > 10, =1 otherwise
	tf-ResourceConfig	prb-Num	5MHz: min{24, 2N-24*iPool} / 2 10MHz: 25 15MHz: min{74, 2N-74*iPool} / 2 20MHz: 50
		prb-Start	0
		prb-End	5 MHz: min{24, 2N-24*iPool} - 1 10 MHz: 49 15 MHz: min{74, 2N-74*iPool} - 1 20 MHz: 99
		offsetIndicator	160
		subframeBitmap	a(0), a(1), ..., a(39), s.t. a(i * NPool + iPool) = 1, i = 0,...,K; a(k) = 0 otherwise where K = 1 is NPool > 10, K = 3 otherwise
	txParameters		not present
	rxParameters		not present
discTxPoolCommon			not present
discTxPowerInfo			not present
SL-SyncConfig			not present
discInterFreqList			not present
NOTE 1: The resource pool configuration description is parameterized using channel BW, number of configured resource pools (NPool), and maximum number of configured Sidelink UEs to be supported (N).			

A.7.1.2 TDD

Table A.7.1.2-1: ProSe Direct Discovery configuration for E-UTRA TDD Config 0 (Configuration #1-TDD)

Information Element			Value
discRxPool	cp-Len		Normal
	discPeriod		rf32
	numRetx		0
	numRepetition		1
	tf-ResourceConfig	prb-Num	12
		prb-Start	0
		prb-End	23
		offsetIndicator	163
		subframeBitmap	10000000 00000000 00000000 00000000 00000000 00
	txParameters		not present
	rxParameters		not present
discTxPoolCommon			not present
discTxPowerInfo			not present
SL-SyncConfig			not present
discInterFreqList			not present

Table A.7.1.2-2: ProSe Direct Discovery configuration for E-UTRA TDD (Configuration #2-TDD)

Information Element			Value
discRxPool(iPool), iPool = 0...NPool-1	cp-Len		Normal
	discPeriod		rf32
	numRetx		3
	numRepetition		=2 if NPool > 10, =1 otherwise
	tf-ResourceConfig	prb-Num	5MHz: $\min\{24, 2N-24*iPool\} / 2$ 10MHz: 25 15MHz: $\min\{74, 2N-74*iPool\} / 2$ 20MHz: 50
		prb-Start	0
		prb-End	5 MHz: $\min\{24, 2N-24*iPool\} - 1$ 10 MHz: 49 15 MHz: $\min\{74, 2N-74*iPool\} - 1$ 20 MHz: 99
		offsetIndicator	163
		subframeBitmap	a(0), a(1), ..., a(39), s.t. a(i * NPool + iPool) = 1, i = 0,...,K; a(k) = 0 otherwise where K = 1 is NPool > 10, K = 3 otherwise
	txParameters		not present
	rxParameters		not present
discTxPoolCommon			not present
discTxPowerInfo			not present
SL-SyncConfig			not present
discInterFreqList			not present
NOTE 1: The resource pool configuration description is parameterized using channel BWs, number of configured resource pools (NPool), and maximum number of configured Sidelink UE to be supported (N).			

A.7.2 Reference resource pool configurations for ProSe Direct Communication demodulation tests

A.7.2.1 FDD

Table A.7.2.1-1: ProSe Direct Communication pre-configuration for E-UTRAN FDD for out-of-network coverage operation (Configuration #1-FDD)

Information Element / (BW configuration)			Value (5MHz)	Value (10MHz)	
preconfigSync	syncCP-Len-r12		Normal		
	syncOffsetIndicator1		1		
	syncOffsetIndicator2		2		
	syncTxParameters		23		
	syncTxThreshOoC		0 (-110dBm / 15kHz)		
	filterCoefficient		fc0		
	syncRefMinHyst		dB0		
	syncRefDiffHyst		dB0		
preconfigComm	sc-CP-Len		Normal		
	sc-Period		sf40		
	sc-TF-ResourceConfig	prb-Num		13	25
		prb-Start		0	0
		prb-End		24	49
		offsetIndicator		0	
		subframeBitmap		00011000 00000000 00000000 00000000 00000000	
	data-CP-Len		Normal		
	dataHoppingConfig	hoppingParameter		504	
		numSubbands		ns2	
rb-Offset			0		
ue-SelectedResourceConfig	data-TF-ResourceConfig	prb-Num	13	25	
		prb-Start	0	0	
		prb-End	24	49	
		offsetIndicator	0		
		subframeBitmap	00000000 11111111 11111111 00000000 00000000		
	trpt-Subset-r12		010		

Table A.7.2.1-2: ProSe Direct Communication configuration for E-UTRA FDD (Configuration #2-FDD)

Information Element / (BW configuration)				Value (5MHz)	Value (10MHz)
commRxPool	sc-CP-Len			Normal	
	sc-Period			sf40	
	sc-TF-ResourceConfig	prb-Num		13	25
		prb-Start		0	0
		prb-End		24	49
		offsetIndicator		0	
		subframeBitmap		00111100 00000000 00000000 00000000 00000000	
	data-CP-Len			Normal	
	dataHoppingConfig	hoppingParameter		504	
		numSubbands		ns2	
		rb-Offset		0	
	ue-SelectedResourceConfig	data-TF-ResourceConfig	prb-Num	13	25
			prb-Start	0	0
			prb-End	24	49
			offsetIndicator	0	
			subframeBitmap	00000000 11111111 11111111 00000000 00000000	
		trpt-Subset-r12		010	
	rxParametersNCell			not present	
	txParameters			not present	
commTxPoolNormalCommon				not present	
SL-SyncConfig				not present	

Table A.7.2.1-3: ProSe Direct Communication configuration for E-UTRA FDD (Configuration #3-FDD)

Information Element / (BW configuration)				Value (5MHz)	Value (10MHz)	
commRxPool(0)	sc-CP-Len			Normal		
	sc-Period			sf40		
	sc-TF-ResourceConfig	prb-Num		13	25	
		prb-Start		0	0	
		prb-End		24	49	
		offsetIndicator		0		
		subframeBitmap		00110000 00000000 00000000 00000000 00000000		
	data-CP-Len			Normal		
	dataHoppingConfig	hoppingParameter		504		
		numSubbands		ns2		
	rb-Offset		0			
commRxPool(1)	ue-SelectedResourceConfig	data-TF-ResourceConfig	prb-Num	13	25	
			prb-Start	0	0	
		prb-End		24	49	
		offsetIndicator		0		
		subframeBitmap		00001111 11110000 00000000 11111111 00000000		
		trpt-Subset-r12		010		
	rxParametersNCell			not present		
	txParameters			not present		
	commRxPool(1)	sc-CP-Len			Normal	
		sc-Period			sf40	
sc-TF-ResourceConfig		prb-Num		13	25	
		prb-Start		0	0	
		prb-End		24	49	
		offsetIndicator		0		
		subframeBitmap		00110000 00000000 00000000 00000000 00000000		
data-CP-Len				Normal		
dataHoppingConfig		hoppingParameter		504		
		numSubbands		ns2		
	rb-Offset		0			
commTxPoolNormalCommon	ue-SelectedResourceConfig	data-TF-ResourceConfig	prb-Num	13	25	
			prb-Start	0	0	
		prb-End		24	49	
		offsetIndicator		0		
		subframeBitmap		00001111 11110000 00001111 11110000 00000000		
		trpt-Subset-r12		010		
	rxParametersNCell	tdd-Config		not present		
		syncConfigIndex		0		
	txParameters			not present		
	SL-SyncConfig(0)	syncCP-Len		Normal		
	syncOffsetIndicator		1			
	slssid		30			
	txParameters		not present			

	rxParamsNCell	physCellId		1
		discSyncWindow		w1

Table A.7.2.1-4: ProSe Direct Communication configuration for E-UTRA FDD (Configuration #4-FDD)

Information Element / (BW configuration)				Value (5MHz)	Value (10MHz)	
commRxPool(0)	sc-CP-Len			Normal		
	sc-Period			sf80		
	sc-TF-ResourceConfig	prb-Num		13	25	
		prb-Start		0	0	
		prb-End		24	49	
		offsetIndicator		0		
		subframeBitmap		11110000 00000000 00000000 00000000 00000000		
	data-CP-Len			Normal		
	dataHoppingConfig	hoppingParameter		504		
		numSubbands		ns2		
	rb-Offset		0			
ue-SelectedResourceConfig	data-TF-ResourceConfig	prb-Num	13	25		
		prb-Start	0	0		
		prb-End		24	49	
		offsetIndicator		0		
		subframeBitmap		00000000 11111111 00000000 11111111 00000000		
		trpt-Subset-r12		001		
	rxParametersNCell			not present		
	txParameters			not present		
	commRxPool(1)	sc-CP-Len			Normal	
		sc-Period			sf80	
sc-TF-ResourceConfig		prb-Num		13	25	
		prb-Start		0	0	
		prb-End		24	49	
		offsetIndicator		0		
		subframeBitmap		00001111 00000000 00000000 00000000 00000000		
data-CP-Len				Normal		
dataHoppingConfig		hoppingParameter		504		
		numSubbands		ns2		
	rb-Offset		0			
ue-SelectedResourceConfig	data-TF-ResourceConfig	prb-Num	13	25		
		prb-Start	0	0		
		prb-End		24	49	
		offsetIndicator		0		
		subframeBitmap		00000000 00000000 11111111 00000000 11111111		
		trpt-Subset-r12		001		
	rxParametersNCell			not present		
	txParameters			not present		
	commTxPoolNormalCommon			not present		
	SL-SyncConfig			not present		

Table A.7.2.1-5: ProSe Direct Communication configuration for E-UTRA FDD (Configuration #5-FDD)

Information Element / (BW configuration)				Value (5MHz)	Value (10MHz)
commRxPool	sc-CP-Len			Normal	
	sc-Period			sf40	
	sc-TF-ResourceConfig	prb-Num		13	25
		prb-Start		0	0
		prb-End		24	49
		offsetIndicator		0	
		subframeBitmap		00011000 00000000 00000000 00000000 00000000	
	data-CP-Len			Normal	
	dataHoppingConfig	hoppingParameter		504	
		numSubbands		ns2	
		rb-Offset		0	
	ue-SelectedResourceConfig	data-TF-ResourceConfig	prb-Num	13	25
			prb-Start		0
			prb-End	24	49
			offsetIndicator	0	
			subframeBitmap	00000000 11111111 11111111 11111111 11111111	
		trpt-Subset-r12		001	
	rxParametersNCell			not present	
	txParameters			not present	
commTxPoolNormalCommon				not present	
SL-SyncConfig				not present	

Annex B (normative): Propagation conditions

B.1 Static propagation condition

For 1 port transmission the channel matrix is defined in the frequency domain by

$$\mathbf{H} = \begin{pmatrix} 1 \\ 1 \end{pmatrix}.$$

For 2 port transmission the channel matrix is defined in the frequency domain by

$$\mathbf{H} = \begin{pmatrix} 1 & j \\ 1 & -j \end{pmatrix}.$$

For 4 port transmission the channel matrix is defined in the frequency domain by

$$\mathbf{H} = \begin{bmatrix} 1 & 1 & j & j \\ 1 & 1 & -j & -j \end{bmatrix}$$

For 8 port transmission the channel matrix is defined in the frequency domain by

$$\mathbf{H} = \begin{bmatrix} 1 & 1 & 1 & 1 & j & j & j & j \\ 1 & 1 & 1 & 1 & -j & -j & -j & -j \end{bmatrix}$$

B.2 Multi-path fading propagation conditions

The multipath propagation conditions consist of several parts:

- A delay profile in the form of a "tapped delay-line", characterized by a number of taps at fixed positions on a sampling grid. The profile can be further characterized by the r.m.s. delay spread and the maximum delay spanned by the taps.
- A combination of channel model parameters that include the Delay profile and the Doppler spectrum, that is characterized by a classical spectrum shape and a maximum Doppler frequency
- A set of correlation matrices defining the correlation between the UE and eNodeB antennas in case of multi-antenna systems.
- Additional multi-path models used for CQI (Channel Quality Indication) tests

B.2.1 Delay profiles

The delay profiles are selected to be representative of low, medium and high delay spread environments. The resulting model parameters are defined in Table B.2.1-1 and the tapped delay line models are defined in Tables B.2.1-2, B.2.1-3 and B.2.1-4.

Table B.2.1-1 Delay profiles for E-UTRA channel models

Model	Number of channel taps	Delay spread (r.m.s.)	Maximum excess tap delay (span)
Extended Pedestrian A (EPA)	7	43 ns	410 ns
Extended Vehicular A model (EVA)	9	357 ns	2510 ns
Extended Typical Urban model (ETU)	9	991 ns	5000 ns

Table B.2.1-2 Extended Pedestrian A model (EPA)

Excess tap delay [ns]	Relative power [dB]
0	0.0
30	-1.0
70	-2.0
90	-3.0
110	-8.0
190	-17.2
410	-20.8

Table B.2.1-3 Extended Vehicular A model (EVA)

Excess tap delay [ns]	Relative power [dB]
0	0.0
30	-1.5
150	-1.4
310	-3.6
370	-0.6
710	-9.1
1090	-7.0
1730	-12.0
2510	-16.9

Table B.2.1-4 Extended Typical Urban model (ETU)

Excess tap delay [ns]	Relative power [dB]
0	-1.0
50	-1.0
120	-1.0
200	0.0
230	0.0
500	0.0
1600	-3.0
2300	-5.0
5000	-7.0

B.2.2 Combinations of channel model parameters

The propagation conditions used for the performance measurements in multi-path fading environment are indicated as EVA[number], EPA[number] or ETU[number] where 'number' indicates the maximum Doppler frequency (Hz).

Table B.2.2-1 Void

B.2.3 MIMO Channel Correlation Matrices

The MIMO channel correlation matrices defined in B.2.3 apply for the antenna configuration using uniform linear arrays at both eNodeB and UE.

B.2.3.1 Definition of MIMO Correlation Matrices

Table B.2.3.1-1 defines the correlation matrix for the eNodeB

Table B.2.3.1-1 eNodeB correlation matrix

	One antenna	Two antennas	Four antennas
eNode B Correlation	$R_{eNB} = 1$	$R_{eNB} = \begin{pmatrix} 1 & \alpha \\ \alpha^* & \mathbf{1} \end{pmatrix}$	$R_{eNB} = \begin{pmatrix} 1 & \alpha^{1/9} & \alpha^{4/9} & \alpha \\ \alpha^{1/9*} & 1 & \alpha^{1/9} & \alpha^{4/9} \\ \alpha^{4/9*} & \alpha^{1/9*} & 1 & \alpha^{1/9} \\ \alpha^* & \alpha^{4/9*} & \alpha^{1/9*} & 1 \end{pmatrix}$

Table B.2.3.1-2 defines the correlation matrix for the UE:

Table B.2.3.1-2 UE correlation matrix

	One antenna	Two antennas	Four antennas
UE Correlation	$R_{UE} = 1$	$R_{UE} = \begin{pmatrix} 1 & \beta \\ \beta^* & \mathbf{1} \end{pmatrix}$	$R_{UE} = \begin{pmatrix} 1 & \beta^{1/9} & \beta^{4/9} & \beta \\ \beta^{1/9*} & 1 & \beta^{1/9} & \beta^{4/9} \\ \beta^{4/9*} & \beta^{1/9*} & 1 & \beta^{1/9} \\ \beta^* & \beta^{4/9*} & \beta^{1/9*} & 1 \end{pmatrix}$

Table B.2.3.1-3 defines the channel spatial correlation matrix R_{spat} . The parameters, α and β in Table B.2.3.1-3 defines the spatial correlation between the antennas at the eNodeB and UE.

Table B.2.3.1-3: R_{spat} correlation matrices

1x2 case	$R_{spat} = R_{UE} = \begin{bmatrix} 1 & \beta \\ \beta^* & 1 \end{bmatrix}$
2x1 case	$R_{spat} = R_{eNB} = \begin{bmatrix} 1 & \alpha \\ \alpha^* & 1 \end{bmatrix}$
2x2 case	$R_{spat} = R_{eNB} \otimes R_{UE} = \begin{bmatrix} 1 & \alpha \\ \alpha^* & 1 \end{bmatrix} \otimes \begin{bmatrix} 1 & \beta \\ \beta^* & 1 \end{bmatrix} = \begin{bmatrix} 1 & \beta & \alpha & \alpha\beta \\ \beta^* & 1 & \alpha\beta^* & \alpha \\ \alpha^* & \alpha^*\beta & 1 & \beta \\ \alpha^*\beta^* & \alpha^* & \beta^* & 1 \end{bmatrix}$
4x2 case	$R_{spat} = R_{eNB} \otimes R_{UE} = \begin{bmatrix} 1 & \alpha^{1/9} & \alpha^{4/9} & \alpha \\ \alpha^{1/9*} & 1 & \alpha^{1/9} & \alpha^{4/9} \\ \alpha^{4/9*} & \alpha^{1/9*} & 1 & \alpha^{1/9} \\ \alpha^* & \alpha^{4/9*} & \alpha^{1/9*} & 1 \end{bmatrix} \otimes \begin{bmatrix} 1 & \beta \\ \beta^* & 1 \end{bmatrix}$
4x4 case	$R_{spat} = R_{eNB} \otimes R_{UE} = \begin{bmatrix} 1 & \alpha^{1/9} & \alpha^{4/9} & \alpha \\ \alpha^{1/9*} & 1 & \alpha^{1/9} & \alpha^{4/9} \\ \alpha^{4/9*} & \alpha^{1/9*} & 1 & \alpha^{1/9} \\ \alpha^* & \alpha^{4/9*} & \alpha^{1/9*} & 1 \end{bmatrix} \otimes \begin{bmatrix} 1 & \beta^{1/9} & \beta^{4/9} & \beta \\ \beta^{1/9*} & 1 & \beta^{1/9} & \beta^{4/9} \\ \beta^{4/9*} & \beta^{1/9*} & 1 & \beta^{1/9} \\ \beta^* & \beta^{4/9*} & \beta^{1/9*} & 1 \end{bmatrix}$

For cases with more antennas at either eNodeB or UE or both, the channel spatial correlation matrix can still be expressed as the Kronecker product of R_{eNB} and R_{UE} according to $R_{spat} = R_{eNB} \otimes R_{UE}$.

B.2.3.2 MIMO Correlation Matrices at High, Medium and Low Level

The α and β for different correlation types are given in Table B.2.3.2-1.

Table B.2.3.2-1

Low correlation		Medium Correlation		High Correlation	
α	β	α	β	α	β
0	0	0.3	0.9	0.9	0.9

The correlation matrices for high, medium and low correlation are defined in Table B.2.3.1-2, B.2.3.2-3 and B.2.3.2-4, as below.

The values in Table B.2.3.2-2 have been adjusted for the 4x2 and 4x4 high correlation cases to insure the correlation matrix is positive semi-definite after round-off to 4 digit precision. This is done using the equation:

$$\mathbf{R}_{high} = [\mathbf{R}_{spatial} + a\mathbf{I}_n] / (1 + a)$$

Where the value “a” is a scaling factor such that the smallest value is used to obtain a positive semi-definite result. For the 4x2 high correlation case, a=0.00010. For the 4x4 high correlation case, a=0.00012.

The same method is used to adjust the 4x4 medium correlation matrix in Table B.2.3.2-3 to insure the correlation matrix is positive semi-definite after round-off to 4 digit precision with a = 0.00012.

Table B.2.3.2-2: MIMO correlation matrices for high correlation

1x2 case	$R_{high} = \begin{pmatrix} 1 & 0.9 \\ 0.9 & 1 \end{pmatrix}$																																																																																																																																																																																																																																																																	
2x1 case	$R_{high} = \begin{pmatrix} 1 & 0.9 \\ 0.9 & 1 \end{pmatrix}$																																																																																																																																																																																																																																																																	
2x2 case	$R_{high} = \begin{pmatrix} 1 & 0.9 & 0.9 & 0.81 \\ 0.9 & 1 & 0.81 & 0.9 \\ 0.9 & 0.81 & 1 & 0.9 \\ 0.81 & 0.9 & 0.9 & 1 \end{pmatrix}$																																																																																																																																																																																																																																																																	
4x2 case	$R_{high} =$	<table border="1"> <tr><td>1.0000</td><td>0.8999</td><td>0.9883</td><td>0.8894</td><td>0.9542</td><td>0.8587</td><td>0.8999</td><td>0.8099</td></tr> <tr><td>0.8999</td><td>1.0000</td><td>0.8894</td><td>0.9883</td><td>0.8587</td><td>0.9542</td><td>0.8099</td><td>0.8999</td></tr> <tr><td>0.9883</td><td>0.8894</td><td>1.0000</td><td>0.8999</td><td>0.9883</td><td>0.8894</td><td>0.9542</td><td>0.8587</td></tr> <tr><td>0.8894</td><td>0.9883</td><td>0.8999</td><td>1.0000</td><td>0.8894</td><td>0.9883</td><td>0.8587</td><td>0.9542</td></tr> <tr><td>0.9542</td><td>0.8587</td><td>0.9883</td><td>0.8894</td><td>1.0000</td><td>0.8999</td><td>0.9883</td><td>0.8894</td></tr> <tr><td>0.8587</td><td>0.9542</td><td>0.8894</td><td>0.9883</td><td>0.8999</td><td>1.0000</td><td>0.8894</td><td>0.9883</td></tr> <tr><td>0.8999</td><td>0.8099</td><td>0.9542</td><td>0.8587</td><td>0.9883</td><td>0.8894</td><td>1.0000</td><td>0.8999</td></tr> <tr><td>0.8099</td><td>0.8999</td><td>0.8587</td><td>0.9542</td><td>0.8894</td><td>0.9883</td><td>0.8999</td><td>1.0000</td></tr> </table>	1.0000	0.8999	0.9883	0.8894	0.9542	0.8587	0.8999	0.8099	0.8999	1.0000	0.8894	0.9883	0.8587	0.9542	0.8099	0.8999	0.9883	0.8894	1.0000	0.8999	0.9883	0.8894	0.9542	0.8587	0.8894	0.9883	0.8999	1.0000	0.8894	0.9883	0.8587	0.9542	0.9542	0.8587	0.9883	0.8894	1.0000	0.8999	0.9883	0.8894	0.8587	0.9542	0.8894	0.9883	0.8999	1.0000	0.8894	0.9883	0.8999	0.8099	0.9542	0.8587	0.9883	0.8894	1.0000	0.8999	0.8099	0.8999	0.8587	0.9542	0.8894	0.9883	0.8999	1.0000																																																																																																																																																																																																
1.0000	0.8999	0.9883	0.8894	0.9542	0.8587	0.8999	0.8099																																																																																																																																																																																																																																																											
0.8999	1.0000	0.8894	0.9883	0.8587	0.9542	0.8099	0.8999																																																																																																																																																																																																																																																											
0.9883	0.8894	1.0000	0.8999	0.9883	0.8894	0.9542	0.8587																																																																																																																																																																																																																																																											
0.8894	0.9883	0.8999	1.0000	0.8894	0.9883	0.8587	0.9542																																																																																																																																																																																																																																																											
0.9542	0.8587	0.9883	0.8894	1.0000	0.8999	0.9883	0.8894																																																																																																																																																																																																																																																											
0.8587	0.9542	0.8894	0.9883	0.8999	1.0000	0.8894	0.9883																																																																																																																																																																																																																																																											
0.8999	0.8099	0.9542	0.8587	0.9883	0.8894	1.0000	0.8999																																																																																																																																																																																																																																																											
0.8099	0.8999	0.8587	0.9542	0.8894	0.9883	0.8999	1.0000																																																																																																																																																																																																																																																											
4x4 case	$R_{high} =$	<table border="1"> <tr><td>1.0000</td><td>0.9882</td><td>0.9541</td><td>0.8999</td><td>0.9882</td><td>0.9767</td><td>0.9430</td><td>0.8894</td><td>0.9541</td><td>0.9430</td><td>0.9105</td><td>0.8587</td><td>0.8999</td><td>0.8894</td><td>0.8587</td><td>0.8099</td></tr> <tr><td>0.9882</td><td>1.0000</td><td>0.9882</td><td>0.9541</td><td>0.9767</td><td>0.9882</td><td>0.9767</td><td>0.9430</td><td>0.9430</td><td>0.9541</td><td>0.9430</td><td>0.9105</td><td>0.8894</td><td>0.8999</td><td>0.8894</td><td>0.8587</td></tr> <tr><td>0.9541</td><td>0.9882</td><td>1.0000</td><td>0.9882</td><td>0.9430</td><td>0.9767</td><td>0.9882</td><td>0.9767</td><td>0.9105</td><td>0.9430</td><td>0.9541</td><td>0.9430</td><td>0.8587</td><td>0.8894</td><td>0.8999</td><td>0.8894</td></tr> <tr><td>0.8999</td><td>0.9541</td><td>0.9882</td><td>1.0000</td><td>0.8894</td><td>0.9430</td><td>0.9767</td><td>0.9882</td><td>0.8587</td><td>0.9105</td><td>0.9430</td><td>0.9541</td><td>0.8099</td><td>0.8587</td><td>0.8894</td><td>0.8999</td></tr> <tr><td>0.9882</td><td>0.9767</td><td>0.9430</td><td>0.8894</td><td>1.0000</td><td>0.9882</td><td>0.9541</td><td>0.8999</td><td>0.9882</td><td>0.9767</td><td>0.9430</td><td>0.8894</td><td>0.9541</td><td>0.9430</td><td>0.9105</td><td>0.8587</td></tr> <tr><td>0.9767</td><td>0.9882</td><td>0.9767</td><td>0.9430</td><td>0.9882</td><td>1.0000</td><td>0.9882</td><td>0.9541</td><td>0.9767</td><td>0.9882</td><td>0.9767</td><td>0.9430</td><td>0.9430</td><td>0.9541</td><td>0.9430</td><td>0.9105</td></tr> <tr><td>0.9430</td><td>0.9767</td><td>0.9882</td><td>0.9767</td><td>0.9541</td><td>0.9882</td><td>1.0000</td><td>0.9882</td><td>0.9430</td><td>0.9767</td><td>0.9882</td><td>0.9767</td><td>0.9105</td><td>0.9430</td><td>0.9541</td><td>0.9430</td></tr> <tr><td>0.8894</td><td>0.9430</td><td>0.9767</td><td>0.9882</td><td>0.8999</td><td>0.9541</td><td>0.9882</td><td>1.0000</td><td>0.8894</td><td>0.9430</td><td>0.9767</td><td>0.9882</td><td>0.8587</td><td>0.9105</td><td>0.9430</td><td>0.9541</td></tr> <tr><td>0.9541</td><td>0.9430</td><td>0.9105</td><td>0.8587</td><td>0.9882</td><td>0.9767</td><td>0.9430</td><td>0.8894</td><td>1.0000</td><td>0.9882</td><td>0.9541</td><td>0.8999</td><td>0.9882</td><td>0.9767</td><td>0.9430</td><td>0.8894</td></tr> <tr><td>0.9430</td><td>0.9541</td><td>0.9430</td><td>0.9105</td><td>0.9767</td><td>0.9882</td><td>0.9767</td><td>0.9430</td><td>0.9882</td><td>1.0000</td><td>0.9882</td><td>0.9541</td><td>0.9767</td><td>0.9882</td><td>0.9767</td><td>0.9430</td></tr> <tr><td>0.9105</td><td>0.9430</td><td>0.9541</td><td>0.9430</td><td>0.9430</td><td>0.9767</td><td>0.9882</td><td>0.9767</td><td>0.9541</td><td>0.9882</td><td>1.0000</td><td>0.9882</td><td>0.9430</td><td>0.9767</td><td>0.9882</td><td>0.9767</td></tr> <tr><td>0.8587</td><td>0.9105</td><td>0.9430</td><td>0.9541</td><td>0.8894</td><td>0.9430</td><td>0.9767</td><td>0.9882</td><td>0.8999</td><td>0.9541</td><td>0.9882</td><td>1.0000</td><td>0.8894</td><td>0.9430</td><td>0.9767</td><td>0.9882</td></tr> <tr><td>0.8999</td><td>0.8894</td><td>0.8587</td><td>0.8099</td><td>0.9541</td><td>0.9430</td><td>0.9105</td><td>0.8587</td><td>0.9882</td><td>0.9767</td><td>0.9430</td><td>0.8894</td><td>1.0000</td><td>0.9882</td><td>0.9541</td><td>0.8999</td></tr> <tr><td>0.8894</td><td>0.8999</td><td>0.8894</td><td>0.8587</td><td>0.9430</td><td>0.9541</td><td>0.9430</td><td>0.9105</td><td>0.9767</td><td>0.9882</td><td>0.9767</td><td>0.9430</td><td>0.9882</td><td>1.0000</td><td>0.9882</td><td>0.9541</td></tr> <tr><td>0.8587</td><td>0.8894</td><td>0.8999</td><td>0.8894</td><td>0.9105</td><td>0.9430</td><td>0.9541</td><td>0.9430</td><td>0.9430</td><td>0.9767</td><td>0.9882</td><td>0.9767</td><td>0.9541</td><td>0.9882</td><td>1.0000</td><td>0.9882</td></tr> <tr><td>0.8099</td><td>0.8587</td><td>0.8894</td><td>0.8999</td><td>0.8587</td><td>0.9105</td><td>0.9430</td><td>0.9541</td><td>0.8894</td><td>0.9430</td><td>0.9767</td><td>0.9882</td><td>0.8999</td><td>0.9541</td><td>0.9882</td><td>1.0000</td></tr> </table>	1.0000	0.9882	0.9541	0.8999	0.9882	0.9767	0.9430	0.8894	0.9541	0.9430	0.9105	0.8587	0.8999	0.8894	0.8587	0.8099	0.9882	1.0000	0.9882	0.9541	0.9767	0.9882	0.9767	0.9430	0.9430	0.9541	0.9430	0.9105	0.8894	0.8999	0.8894	0.8587	0.9541	0.9882	1.0000	0.9882	0.9430	0.9767	0.9882	0.9767	0.9105	0.9430	0.9541	0.9430	0.8587	0.8894	0.8999	0.8894	0.8999	0.9541	0.9882	1.0000	0.8894	0.9430	0.9767	0.9882	0.8587	0.9105	0.9430	0.9541	0.8099	0.8587	0.8894	0.8999	0.9882	0.9767	0.9430	0.8894	1.0000	0.9882	0.9541	0.8999	0.9882	0.9767	0.9430	0.8894	0.9541	0.9430	0.9105	0.8587	0.9767	0.9882	0.9767	0.9430	0.9882	1.0000	0.9882	0.9541	0.9767	0.9882	0.9767	0.9430	0.9430	0.9541	0.9430	0.9105	0.9430	0.9767	0.9882	0.9767	0.9541	0.9882	1.0000	0.9882	0.9430	0.9767	0.9882	0.9767	0.9105	0.9430	0.9541	0.9430	0.8894	0.9430	0.9767	0.9882	0.8999	0.9541	0.9882	1.0000	0.8894	0.9430	0.9767	0.9882	0.8587	0.9105	0.9430	0.9541	0.9541	0.9430	0.9105	0.8587	0.9882	0.9767	0.9430	0.8894	1.0000	0.9882	0.9541	0.8999	0.9882	0.9767	0.9430	0.8894	0.9430	0.9541	0.9430	0.9105	0.9767	0.9882	0.9767	0.9430	0.9882	1.0000	0.9882	0.9541	0.9767	0.9882	0.9767	0.9430	0.9105	0.9430	0.9541	0.9430	0.9430	0.9767	0.9882	0.9767	0.9541	0.9882	1.0000	0.9882	0.9430	0.9767	0.9882	0.9767	0.8587	0.9105	0.9430	0.9541	0.8894	0.9430	0.9767	0.9882	0.8999	0.9541	0.9882	1.0000	0.8894	0.9430	0.9767	0.9882	0.8999	0.8894	0.8587	0.8099	0.9541	0.9430	0.9105	0.8587	0.9882	0.9767	0.9430	0.8894	1.0000	0.9882	0.9541	0.8999	0.8894	0.8999	0.8894	0.8587	0.9430	0.9541	0.9430	0.9105	0.9767	0.9882	0.9767	0.9430	0.9882	1.0000	0.9882	0.9541	0.8587	0.8894	0.8999	0.8894	0.9105	0.9430	0.9541	0.9430	0.9430	0.9767	0.9882	0.9767	0.9541	0.9882	1.0000	0.9882	0.8099	0.8587	0.8894	0.8999	0.8587	0.9105	0.9430	0.9541	0.8894	0.9430	0.9767	0.9882	0.8999	0.9541	0.9882	1.0000
1.0000	0.9882	0.9541	0.8999	0.9882	0.9767	0.9430	0.8894	0.9541	0.9430	0.9105	0.8587	0.8999	0.8894	0.8587	0.8099																																																																																																																																																																																																																																																			
0.9882	1.0000	0.9882	0.9541	0.9767	0.9882	0.9767	0.9430	0.9430	0.9541	0.9430	0.9105	0.8894	0.8999	0.8894	0.8587																																																																																																																																																																																																																																																			
0.9541	0.9882	1.0000	0.9882	0.9430	0.9767	0.9882	0.9767	0.9105	0.9430	0.9541	0.9430	0.8587	0.8894	0.8999	0.8894																																																																																																																																																																																																																																																			
0.8999	0.9541	0.9882	1.0000	0.8894	0.9430	0.9767	0.9882	0.8587	0.9105	0.9430	0.9541	0.8099	0.8587	0.8894	0.8999																																																																																																																																																																																																																																																			
0.9882	0.9767	0.9430	0.8894	1.0000	0.9882	0.9541	0.8999	0.9882	0.9767	0.9430	0.8894	0.9541	0.9430	0.9105	0.8587																																																																																																																																																																																																																																																			
0.9767	0.9882	0.9767	0.9430	0.9882	1.0000	0.9882	0.9541	0.9767	0.9882	0.9767	0.9430	0.9430	0.9541	0.9430	0.9105																																																																																																																																																																																																																																																			
0.9430	0.9767	0.9882	0.9767	0.9541	0.9882	1.0000	0.9882	0.9430	0.9767	0.9882	0.9767	0.9105	0.9430	0.9541	0.9430																																																																																																																																																																																																																																																			
0.8894	0.9430	0.9767	0.9882	0.8999	0.9541	0.9882	1.0000	0.8894	0.9430	0.9767	0.9882	0.8587	0.9105	0.9430	0.9541																																																																																																																																																																																																																																																			
0.9541	0.9430	0.9105	0.8587	0.9882	0.9767	0.9430	0.8894	1.0000	0.9882	0.9541	0.8999	0.9882	0.9767	0.9430	0.8894																																																																																																																																																																																																																																																			
0.9430	0.9541	0.9430	0.9105	0.9767	0.9882	0.9767	0.9430	0.9882	1.0000	0.9882	0.9541	0.9767	0.9882	0.9767	0.9430																																																																																																																																																																																																																																																			
0.9105	0.9430	0.9541	0.9430	0.9430	0.9767	0.9882	0.9767	0.9541	0.9882	1.0000	0.9882	0.9430	0.9767	0.9882	0.9767																																																																																																																																																																																																																																																			
0.8587	0.9105	0.9430	0.9541	0.8894	0.9430	0.9767	0.9882	0.8999	0.9541	0.9882	1.0000	0.8894	0.9430	0.9767	0.9882																																																																																																																																																																																																																																																			
0.8999	0.8894	0.8587	0.8099	0.9541	0.9430	0.9105	0.8587	0.9882	0.9767	0.9430	0.8894	1.0000	0.9882	0.9541	0.8999																																																																																																																																																																																																																																																			
0.8894	0.8999	0.8894	0.8587	0.9430	0.9541	0.9430	0.9105	0.9767	0.9882	0.9767	0.9430	0.9882	1.0000	0.9882	0.9541																																																																																																																																																																																																																																																			
0.8587	0.8894	0.8999	0.8894	0.9105	0.9430	0.9541	0.9430	0.9430	0.9767	0.9882	0.9767	0.9541	0.9882	1.0000	0.9882																																																																																																																																																																																																																																																			
0.8099	0.8587	0.8894	0.8999	0.8587	0.9105	0.9430	0.9541	0.8894	0.9430	0.9767	0.9882	0.8999	0.9541	0.9882	1.0000																																																																																																																																																																																																																																																			

Table B.2.3.2-3: MIMO correlation matrices for medium correlation

1x2 case	N/A
2x1 case	N/A
2x2 case	$R_{medium} = \begin{pmatrix} 1 & 0.9 & 0.3 & 0.27 \\ 0.9 & 1 & 0.27 & 0.3 \\ 0.3 & 0.27 & 1 & 0.9 \\ 0.27 & 0.3 & 0.9 & 1 \end{pmatrix}$
4x2 case	$R_{medium} = \begin{pmatrix} 1.0000 & 0.9000 & 0.8748 & 0.7873 & 0.5856 & 0.5271 & 0.3000 & 0.2700 \\ 0.9000 & 1.0000 & 0.7873 & 0.8748 & 0.5271 & 0.5856 & 0.2700 & 0.3000 \\ 0.8748 & 0.7873 & 1.0000 & 0.9000 & 0.8748 & 0.7873 & 0.5856 & 0.5271 \\ 0.7873 & 0.8748 & 0.9000 & 1.0000 & 0.7873 & 0.8748 & 0.5271 & 0.5856 \\ 0.5856 & 0.5271 & 0.8748 & 0.7873 & 1.0000 & 0.9000 & 0.8748 & 0.7873 \\ 0.5271 & 0.5856 & 0.7873 & 0.8748 & 0.9000 & 1.0000 & 0.7873 & 0.8748 \\ 0.3000 & 0.2700 & 0.5856 & 0.5271 & 0.8748 & 0.7873 & 1.0000 & 0.9000 \\ 0.2700 & 0.3000 & 0.5271 & 0.5856 & 0.7873 & 0.8748 & 0.9000 & 1.0000 \end{pmatrix}$
4x4 case	$R_{medium} = \begin{pmatrix} 1.0000 & 0.9882 & 0.9541 & 0.8999 & 0.8747 & 0.8645 & 0.8347 & 0.7872 & 0.5855 & 0.5787 & 0.5588 & 0.5270 & 0.3000 & 0.2965 & 0.2862 & 0.2700 \\ 0.9882 & 1.0000 & 0.9882 & 0.9541 & 0.8645 & 0.8747 & 0.8645 & 0.8347 & 0.5787 & 0.5855 & 0.5787 & 0.5588 & 0.2965 & 0.3000 & 0.2965 & 0.2862 \\ 0.9541 & 0.9882 & 1.0000 & 0.9882 & 0.8347 & 0.8645 & 0.8747 & 0.8645 & 0.5588 & 0.5787 & 0.5855 & 0.5787 & 0.2862 & 0.2965 & 0.3000 & 0.2965 \\ 0.8999 & 0.9541 & 0.9882 & 1.0000 & 0.7872 & 0.8347 & 0.8645 & 0.8747 & 0.5270 & 0.5588 & 0.5787 & 0.5855 & 0.2700 & 0.2862 & 0.2965 & 0.3000 \\ 0.8747 & 0.8645 & 0.8347 & 0.7872 & 1.0000 & 0.9882 & 0.9541 & 0.8999 & 0.8747 & 0.8645 & 0.8347 & 0.7872 & 0.5855 & 0.5787 & 0.5588 & 0.5270 \\ 0.8645 & 0.8747 & 0.8645 & 0.8347 & 0.9882 & 1.0000 & 0.9882 & 0.9541 & 0.8645 & 0.8747 & 0.8645 & 0.8347 & 0.5787 & 0.5855 & 0.5787 & 0.5588 \\ 0.8347 & 0.8645 & 0.8747 & 0.8645 & 0.9541 & 0.9882 & 1.0000 & 0.9882 & 0.8347 & 0.8645 & 0.8747 & 0.8645 & 0.5588 & 0.5787 & 0.5855 & 0.5787 \\ 0.7872 & 0.8347 & 0.8645 & 0.8747 & 0.8999 & 0.9541 & 0.9882 & 1.0000 & 0.7872 & 0.8347 & 0.8645 & 0.8747 & 0.5270 & 0.5588 & 0.5787 & 0.5855 \\ 0.5855 & 0.5787 & 0.5588 & 0.5270 & 0.8747 & 0.8645 & 0.8347 & 0.7872 & 1.0000 & 0.9882 & 0.9541 & 0.8999 & 0.8747 & 0.8645 & 0.8347 & 0.7872 \\ 0.5787 & 0.5855 & 0.5787 & 0.5588 & 0.8645 & 0.8747 & 0.8645 & 0.8347 & 0.9882 & 1.0000 & 0.9882 & 0.9541 & 0.8645 & 0.8747 & 0.8645 & 0.8347 \\ 0.5588 & 0.5787 & 0.5855 & 0.5787 & 0.8347 & 0.8645 & 0.8747 & 0.8645 & 0.9541 & 0.9882 & 1.0000 & 0.9882 & 0.8347 & 0.8645 & 0.8747 & 0.8645 \\ 0.5270 & 0.5588 & 0.5787 & 0.5855 & 0.7872 & 0.8347 & 0.8645 & 0.8747 & 0.8999 & 0.9541 & 0.9882 & 1.0000 & 0.7872 & 0.8347 & 0.8645 & 0.8747 \\ 0.3000 & 0.2965 & 0.2862 & 0.2700 & 0.5855 & 0.5787 & 0.5588 & 0.5270 & 0.8747 & 0.8645 & 0.8347 & 0.7872 & 1.0000 & 0.9882 & 0.9541 & 0.8999 \\ 0.2965 & 0.3000 & 0.2965 & 0.2862 & 0.5787 & 0.5855 & 0.5787 & 0.5588 & 0.8645 & 0.8747 & 0.8645 & 0.8347 & 0.9882 & 1.0000 & 0.9882 & 0.9541 \\ 0.2862 & 0.2965 & 0.3000 & 0.2965 & 0.5588 & 0.5787 & 0.5855 & 0.5787 & 0.8347 & 0.8645 & 0.8747 & 0.8645 & 0.9541 & 0.9882 & 1.0000 & 0.9882 \\ 0.2700 & 0.2862 & 0.2965 & 0.3000 & 0.5270 & 0.5588 & 0.5787 & 0.5855 & 0.7872 & 0.8347 & 0.8645 & 0.8747 & 0.8999 & 0.9541 & 0.9882 & 1.0000 \end{pmatrix}$

Table B.2.3.2-4: MIMO correlation matrices for low correlation

1x2 case	$R_{low} = \mathbf{I}_2$
2x1 case	$R_{low} = \mathbf{I}_2$
2x2 case	$R_{low} = \mathbf{I}_4$
4x2 case	$R_{low} = \mathbf{I}_8$
4x4 case	$R_{low} = \mathbf{I}_{16}$

In Table B.2.3.2-4, \mathbf{I}_d is the $d \times d$ identity matrix.

B.2.3A MIMO Channel Correlation Matrices using cross polarized antennas

The MIMO channel correlation matrices defined in B.2.3A apply for the antenna configuration using cross polarized (XP/X-pol) antennas at both eNodeB and UE. The cross-polarized antenna elements with +/-45 degrees polarization

slant angles are deployed at eNB and cross-polarized antenna elements with +90/0 degrees polarization slant angles are deployed at UE.

For the cross-polarized antennas, the N antennas are labelled such that antennas for one polarization are listed from 1 to $N/2$ and antennas for the other polarization are listed from $N/2+1$ to N , where N is the number of transmit or receive antennas.

B.2.3A.1 Definition of MIMO Correlation Matrices using cross polarized antennas

For the channel spatial correlation matrix, the following is used:

$$R_{spat} = P(R_{eNB} \otimes \Gamma \otimes R_{UE})P^T$$

where

- R_{UE} is the spatial correlation matrix at the UE with same polarization,
- R_{eNB} is the spatial correlation matrix at the eNB with same polarization,
- Γ is a polarization correlation matrix, and
- $(\bullet)^T$ denotes transpose.

The matrix Γ is defined as

$$\Gamma = \begin{bmatrix} 1 & 0 & -\gamma & 0 \\ 0 & 1 & 0 & \gamma \\ -\gamma & 0 & 1 & 0 \\ 0 & \gamma & 0 & 1 \end{bmatrix}$$

A permutation matrix P elements are defined as

$$P(a,b) = \begin{cases} 1 & \text{for } a = (j-1)N_r + i \text{ and } b = 2(j-1)N_r + i, & i = 1, \dots, N_r, j = 1, \dots, N_t/2 \\ 1 & \text{for } a = (j-1)N_r + i \text{ and } b = 2(j - N_t/2)N_r - N_r + i, & i = 1, \dots, N_r, j = N_t/2 + 1, \dots, N_t \\ 0 & \text{otherwise} \end{cases}$$

where N_t and N_r is the number of transmitter and receiver respectively. This is used to map the spatial correlation coefficients in accordance with the antenna element labelling system described in B.2.3A.

B.2.3A.2 Spatial Correlation Matrices using cross polarized antennas at eNB and UE sides

B.2.3A.2.1 Spatial Correlation Matrices at eNB side

For 2-antenna transmitter using one pair of cross-polarized antenna elements, $R_{eNB} = \mathbf{1}$.

For 4-antenna transmitter using two pairs of cross-polarized antenna elements, $R_{eNB} = \begin{pmatrix} 1 & \alpha \\ \alpha^* & \mathbf{1} \end{pmatrix}$.

For 8-antenna transmitter using four pairs of cross-polarized antenna elements, $R_{eNB} = \begin{pmatrix} 1 & \alpha^{1/9} & \alpha^{4/9} & \alpha \\ \alpha^{1/9*} & 1 & \alpha^{1/9} & \alpha^{4/9} \\ \alpha^{4/9*} & \alpha^{1/9*} & 1 & \alpha^{1/9} \\ \alpha^* & \alpha^{4/9*} & \alpha^{1/9*} & 1 \end{pmatrix}$.

B.2.3A.2.2 Spatial Correlation Matrices at UE side

For 2-antenna receiver using one pair of cross-polarized antenna elements, $R_{UE} = 1$.

For 4-antenna receiver using two pairs of cross-polarized antenna elements, $R_{UE} = \begin{pmatrix} 1 & \beta \\ \beta^* & 1 \end{pmatrix}$.

B.2.3A.3 MIMO Correlation Matrices using cross polarized antennas

The values for parameters α , β and γ for high spatial correlation are given in Table B.2.3A.3-1.

Table B.2.3A.3-1

High spatial correlation		
α	β	γ
0.9	0.9	0.3
Note 1: Value of α applies when more than one pair of cross-polarized antenna elements at eNB side.		
Note 2: Value of β applies when more than one pair of cross-polarized antenna elements at UE side.		

The correlation matrices for high spatial correlation are defined in Table B.2.3A.3-2 as below.

The values in Table B.2.3A.3-2 have been adjusted to insure the correlation matrix is positive semi-definite after round-off to 4 digit precision. This is done using the equation:

$$\mathbf{R}_{high} = [\mathbf{R}_{spat} + a\mathbf{I}_n] / (1 + a)$$

Where the value “a” is a scaling factor such that the smallest value is used to obtain a positive semi-definite result. For the 8x2 high spatial correlation case, a=0.00010.

Table B.2.3A.3-2: MIMO correlation matrices for high spatial correlation

4x2 case	$R_{high} =$	1.0000 0.0000 0.9000 0.0000 -0.3000 0.0000 -0.2700 0.0000
		0.0000 1.0000 0.0000 0.9000 0.0000 0.3000 0.0000 0.2700
		0.9000 0.0000 1.0000 0.0000 -0.2700 0.0000 -0.3000 0.0000
		0.0000 0.9000 0.0000 1.0000 0.0000 0.2700 0.0000 0.3000
		-0.3000 0.0000 -0.2700 0.0000 1.0000 0.0000 0.9000 0.0000
		0.0000 0.3000 0.0000 0.2700 0.0000 1.0000 0.0000 0.9000
		-0.2700 0.0000 -0.3000 0.0000 0.9000 0.0000 1.0000 0.0000
		0.0000 0.2700 0.0000 0.3000 0.0000 0.9000 0.0000 1.0000
8x2 case	$R_{high} =$	1.0000 0.0000 0.9883 0.0000 0.9542 0.0000 0.8999 0.0000 -0.3000 0.0000 -0.2965 0.0000 -0.2862 0.0000 -0.2700 0.0000
		0.0000 1.0000 0.0000 0.9883 0.0000 0.9542 0.0000 0.8999 0.0000 0.3000 0.0000 0.2965 0.0000 0.2862 0.0000 0.2700
		0.9883 0.0000 1.0000 0.0000 0.9883 0.0000 0.9542 0.0000 -0.2965 0.0000 -0.3000 0.0000 -0.2965 0.0000 -0.2862 0.0000
		0.0000 0.9883 0.0000 1.0000 0.0000 0.9883 0.0000 0.9542 0.0000 0.2965 0.0000 0.3000 0.0000 0.2965 0.0000 0.2862
		0.9542 0.0000 0.9883 0.0000 1.0000 0.0000 0.9883 0.0000 -0.2862 0.0000 -0.2965 0.0000 -0.3000 0.0000 -0.2965 0.0000
		0.0000 0.9542 0.0000 0.9883 0.0000 1.0000 0.0000 0.9883 0.0000 0.2862 0.0000 0.2965 0.0000 0.3000 0.0000 0.2965
		0.8999 0.0000 0.9542 0.0000 0.9883 0.0000 1.0000 0.0000 -0.2700 0.0000 -0.2862 0.0000 -0.2965 0.0000 -0.3000 0.0000
		0.0000 0.8999 0.0000 0.9542 0.0000 0.9883 0.0000 1.0000 0.0000 0.2700 0.0000 0.2862 0.0000 0.2965 0.0000 0.3000
		-0.3000 0.0000 -0.2965 0.0000 -0.2862 0.0000 -0.2700 0.0000 1.0000 0.0000 0.9883 0.0000 0.9542 0.0000 0.8999 0.0000
		0.0000 0.3000 0.0000 0.2965 0.0000 0.2862 0.0000 0.2700 0.0000 1.0000 0.0000 0.9883 0.0000 0.9542 0.0000 0.8999
		-0.2965 0.0000 -0.3000 0.0000 -0.2965 0.0000 -0.2862 0.0000 0.9883 0.0000 1.0000 0.0000 0.9883 0.0000 0.9542 0.0000
		0.0000 0.2965 0.0000 0.3000 0.0000 0.2965 0.0000 0.2862 0.0000 0.9883 0.0000 1.0000 0.0000 0.9883 0.0000 0.9542
		-0.2862 0.0000 -0.2965 0.0000 -0.3000 0.0000 -0.2965 0.0000 0.9542 0.0000 0.9883 0.0000 1.0000 0.0000 0.9883 0.0000
		0.0000 0.2862 0.0000 0.2965 0.0000 0.3000 0.0000 0.2965 0.0000 0.9542 0.0000 0.9883 0.0000 1.0000 0.0000 0.9883
		-0.2700 0.0000 -0.2862 0.0000 -0.2965 0.0000 -0.3000 0.0000 0.8999 0.0000 0.9542 0.0000 0.9883 0.0000 1.0000 0.0000
		0.0000 0.2700 0.0000 0.2862 0.0000 0.2965 0.0000 0.3000 0.0000 0.8999 0.0000 0.9542 0.0000 0.9883 0.0000 1.0000

B.2.3A.4 Beam steering approach

Given the channel spatial correlation matrix in B.2.3A.1, the corresponding random channel matrix \mathbf{H} can be calculated. The signal model for the k -th subframe is denoted as

$$y = \mathbf{H}D_{\theta_k}Wx + n$$

Where

- \mathbf{H} is the $N_r \times N_t$ channel matrix per subcarrier.
- D_{θ_k} is the steering matrix,

For 8 transmission antennas, $D_{\theta_k} = \begin{bmatrix} 1 & 0 \\ 0 & 1 \end{bmatrix} \otimes \begin{bmatrix} 1 & 0 & 0 & 0 \\ 0 & e^{j\theta_k} & 0 & 0 \\ 0 & 0 & e^{j2\theta_k} & 0 \\ 0 & 0 & 0 & e^{j3\theta_k} \end{bmatrix};$

For 4 transmission antennas, $D_{\theta_k} = \begin{bmatrix} 1 & 0 \\ 0 & 1 \end{bmatrix} \otimes \begin{bmatrix} 1 & 0 \\ 0 & e^{j3\theta_k} \end{bmatrix}.$

- θ_k controls the phase variation, and the phase for k -th subframe is denoted by $\theta_k = \theta_0 + \Delta\theta \cdot k$, where θ_0 is the random start value with the uniform distribution, i.e., $\theta_0 \in [0, 2\pi]$, $\Delta\theta$ is the step of phase variation, which is defined in Table B.2.3A.4-1, and k is the linear increment of 1 for every subframe throughout the simulation,
- W is the precoding matrix for N_t transmission antennas,
- y is the received signal, x is the transmitted signal, and n is AWGN.

Table B.2.3A.4-1: The step of phase variation

Variation Step	Value (rad/subframe)
$\Delta\theta$	1.2566×10^{-3}

B.2.4 Propagation conditions for CQI tests

For Channel Quality Indication (CQI) tests, the following additional multi-path profile is used:

$$h(t, \tau) = \delta(\tau) + a \exp(-i2\pi f_D t) \delta(\tau - \tau_d),$$

in continuous time (t, τ) representation, with τ_d the delay, a a constant and f_D the Doppler frequency. The same $h(t, \tau)$ is used to describe the fading channel between every pair of Tx and Rx.

B.2.4.1 Propagation conditions for CQI tests with multiple CSI processes

For CQI tests with multiple CSI processes, the following additional multi-path profile is used for 2 port transmission:

$$H = \begin{bmatrix} 1 & j \\ 1 & -j \end{bmatrix} \circ H_{MP}$$

Where \circ represents Hadamard product, H_{MP} indicates the 2×2 propagation channel generated in the manner defined in Clause B.2.4.

B.2.5 Void

B.2.6 MBSFN Propagation Channel Profile

Table B.2.6-1 shows propagation conditions that are used for the MBSFN performance requirements in multi-path fading environment in an extended delay spread environment.

Table B.2.6-1: Propagation Conditions for Multi-Path Fading Environments for MBSFN Performance Requirements in an extended delay spread environment

Extended Delay Spread	
Maximum Doppler frequency [5Hz]	
Relative Delay [ns]	Relative Mean Power [dB]
0	0
30	-1.5
150	-1.4
310	-3.6
370	-0.6
1090	-7.0
12490	-10
12520	-11.5
12640	-11.4
12800	-13.6
12860	-10.6
13580	-17.0
27490	-20
27520	-21.5
27640	-21.4
27800	-23.6
27860	-20.6
28580	-27.0

B.3 High speed train scenario

The high speed train condition for the test of the baseband performance is a non fading propagation channel with one tap. Doppler shift is given by

$$f_s(t) = f_d \cos \theta(t) \quad (\text{B.3.1})$$

where $f_s(t)$ is the Doppler shift and f_d is the maximum Doppler frequency. The cosine of angle $\theta(t)$ is given by

$$\cos \theta(t) = \frac{D_s/2 - vt}{\sqrt{D_{\min}^2 + (D_s/2 - vt)^2}}, \quad 0 \leq t \leq D_s/v \quad (\text{B.3.2})$$

$$\cos \theta(t) = \frac{-1.5D_s + vt}{\sqrt{D_{\min}^2 + (-1.5D_s + vt)^2}}, \quad D_s/v < t \leq 2D_s/v \quad (\text{B.3.3})$$

$$\cos \theta(t) = \cos \theta(t \bmod (2D_s/v)), \quad t > 2D_s/v \quad (\text{B.3.4})$$

where $D_s/2$ is the initial distance of the train from eNodeB, and D_{\min} is eNodeB Railway track distance, both in meters; v is the velocity of the train in m/s, t is time in seconds.

Doppler shift and cosine angle are given by equation B.3.1 and B.3.2-B.3.4 respectively, where the required input parameters listed in table B.3-1 and the resulting Doppler shift shown in Figure B.3-1 are applied for all frequency bands.

Table B.3-1: High speed train scenario

Parameter	Value
D_s	300 m
D_{\min}	2 m
v	300 km/h
f_d	750 Hz

NOTE 1: Parameters for HST conditions in table B.3-1 including f_d and Doppler shift trajectories presented on figure B.3-1 were derived from Band 7 and are applied for performance verification in all frequency bands.

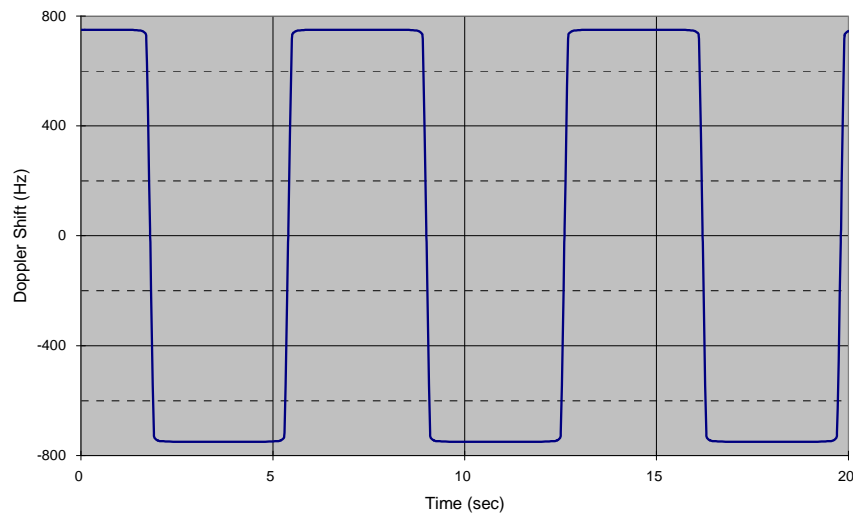

Figure B.3-1: Doppler shift trajectory

For 1x2 antenna configuration, the same $h(t,\tau)$ is used to describe the channel between every pair of Tx and Rx.

For 2x2 antenna configuration, the same $h(t,\tau)$ is used to describe the channel between every pair of Tx and Rx with phase shift according to $\mathbf{H} = \begin{pmatrix} 1 & j \\ 1 & -j \end{pmatrix}$.

B.4 Beamforming Model

B.4.1 Single-layer random beamforming (Antenna port 5, 7, or 8)

Single-layer transmission on antenna port 5 or on antenna port 7 or 8 without a simultaneous transmission on the other antenna port, is defined by using a precoder vector $W(i)$ of size 2×1 randomly selected with the number of layers $\nu = 1$ from Table 6.3.4.2.3-1 in [4] as beamforming weights. This precoder takes as an input the signal $y^{(p)}(i)$, $i = 0, 1, \dots, M_{\text{symp}}^{\text{ap}} - 1$, for antenna port $p \in \{5, 7, 8\}$, with $M_{\text{symp}}^{\text{ap}}$ the number of modulation symbols including the

user-specific reference symbols (DRS), and generates a block of signals $y_{bf}(i) = [y_{bf}(i) \ \tilde{y}_{bf}(i)]^T$ the elements of which are to be mapped onto the same physical RE but transmitted on different antenna elements:

$$\begin{bmatrix} y_{bf}(i) \\ \tilde{y}_{bf}(i) \end{bmatrix} = W(i)y^{(p)}(i)$$

Single-layer transmission on antenna port 7 or 8 with a simultaneous transmission on the other antenna port, is defined by using a pair of precoder vectors $W_1(i)$ and $W_2(i)$ each of size 2×1 , which are not identical and randomly selected with the number of layers $\nu = 1$ from Table 6.3.4.2.3-1 in [4], as beamforming weights, and normalizing the transmit power as follows:

$$\begin{bmatrix} y_{bf}(i) \\ \tilde{y}_{bf}(i) \end{bmatrix} = \frac{1}{\sqrt{2}} (W_1(i)y^{(7)}(i) + W_2(i)y^{(8)}(i))$$

The precoder update granularity is specific to a test case.

The CSI reference symbols $a_{k,l}^{(p)}$ satisfying $p \bmod 2 = 1$, $p \in \{15,16,\dots,22\}$, are transmitted on the same physical antenna element as the modulation symbols $y_{bf}(i)$. The CSI reference symbols $a_{k,l}^{(p)}$ satisfying $p \bmod 2 = 0$, $p \in \{15,16,\dots,22\}$, are transmitted on the same physical antenna element as the modulation symbols $\tilde{y}_{bf}(i)$.

B.4.2 Dual-layer random beamforming (antenna ports 7 and 8)

Dual-layer transmission on antenna ports 7 and 8 is defined by using a precoder matrix $W(i)$ of size 2×2 randomly selected with the number of layers $\nu = 2$ from Table 6.3.4.2.3-1 in [4] as beamforming weights. This precoder takes as an input a block of signals for antenna ports 7 and 8, $y(i) = [y^{(7)}(i) \ y^{(8)}(i)]^T$, $i = 0,1,\dots, M_{\text{symb}}^{\text{ap}} - 1$, with $M_{\text{symb}}^{\text{ap}}$ being the number of modulation symbols per antenna port including the user-specific reference symbols, and generates a block of signals $y_{bf}(i) = [y_{bf}(i) \ \tilde{y}_{bf}(i)]^T$ the elements of which are to be mapped onto the same physical RE but transmitted on different antenna elements:

$$\begin{bmatrix} y_{bf}(i) \\ \tilde{y}_{bf}(i) \end{bmatrix} = W(i) \begin{bmatrix} y^{(7)}(i) \\ y^{(8)}(i) \end{bmatrix},$$

The precoder update granularity is specific to a test case.

The CSI reference symbols $a_{k,l}^{(p)}$ satisfying $p \bmod 2 = 1$, $p \in \{15,16,\dots,22\}$, are transmitted on the same physical antenna element as the modulation symbols $y_{bf}(i)$. The CSI reference symbols $a_{k,l}^{(p)}$ satisfying $p \bmod 2 = 0$, $p \in \{15,16,\dots,22\}$, are transmitted on the same physical antenna element as the modulation symbols $\tilde{y}_{bf}(i)$.

B.4.3 Generic beamforming model (antenna ports 7-14)

The transmission on antenna port(s) $p = 7,8,\dots,\nu + 6$ is defined by using a precoder matrix $W(i)$ of size $N_{\text{CSI}} \times \nu$, where N_{CSI} is the number of CSI reference signals configured per test and ν is the number of spatial layers. This precoder takes as an input a block of signals for antenna port(s) $p = 7,8,\dots,\nu + 6$, $y^{(p)}(i) = [y^{(7)}(i) \ y^{(8)}(i) \ \dots \ y^{(6+\nu)}(i)]$, $i = 0,1,\dots, M_{\text{symb}}^{\text{ap}} - 1$, with $M_{\text{symb}}^{\text{ap}}$ being the number of modulation symbols per antenna port including the user-specific reference symbols (DM-RS), and generates a block of signals $y_{bf}^{(q)}(i) = [y_{bf}^{(0)}(i) \ y_{bf}^{(1)}(i) \ \dots \ y_{bf}^{(N_{\text{CSI}}-1)}(i)]^T$ the elements of which are to be mapped onto the same time-frequency index pair (k, l) but transmitted on different physical antenna elements:

$$\begin{bmatrix} y_{bf}^{(0)}(i) \\ y_{bf}^{(1)}(i) \\ \vdots \\ y_{bf}^{(N_{CSI}-1)}(i) \end{bmatrix} = W(i) \begin{bmatrix} y^{(7)}(i) \\ y^{(8)}(i) \\ \vdots \\ y^{(6+v)}(i) \end{bmatrix}$$

The precoder matrix $W(i)$ is specific to a test case.

The physical antenna elements are identified by indices $j = 0, 1, \dots, N_{ANT} - 1$, where $N_{ANT} = N_{CSI}$ is the number of physical antenna elements configured per test.

Modulation symbols $y_{bf}^{(q)}(i)$ with $q \in \{0, 1, \dots, N_{CSI} - 1\}$ (i.e. beamformed PDSCH and DM-RS) are mapped to the physical antenna index $j = q$.

Modulation symbols $y^{(p)}(i)$ with $p \in \{0, 1, \dots, P - 1\}$ (i.e. PBCH, PDCCH, PHICH, PCFICH) are mapped to the physical antenna index $j = p$, where P is the number of cell-specific reference signals configured per test.

Modulation symbols $a_{k,l}^{(p)}$ with $p \in \{0, 1, \dots, P - 1\}$ (i.e. CRS) are mapped to the physical antenna index $j = p$, where P is the number of cell-specific reference signals configured per test.

Modulation symbols $a_{k,l}^{(p)}$ with $p \in \{15, 16, \dots, 14 + N_{CSI}\}$ (i.e. CSI-RS) are mapped to the physical antenna index $j = p - 15$, where N_{CSI} is the number of CSI reference signals configured per test.

B.4.4 Random beamforming for EPDCCH distributed transmission (Antenna port 107 and 109)

EPDCCH distributed transmission on antenna port 107 and antenna port 109 is defined by using a pair of precoder vectors $W_1(i)$ and $W_2(i)$ each of size 2×1 , which are not identical and randomly selected per EPDCCH PRB pair with the number of layers $\nu = 1$ from Table 6.3.4.2.3-1 in [4], as beamforming weights. This precoder takes as an input the signal $y^{(p)}(i)$, $i = 0, 1, \dots, M_{\text{symp}}^{\text{ap}} - 1$, for antenna port $p \in \{107, 109\}$, with $M_{\text{symp}}^{\text{ap}}$ the number of modulation symbols including the user-specific reference symbols (DMRS), and generates a block of signals $y_{bf}(i) = [y_{bf}(i) \quad \tilde{y}_{bf}(i)]^T$. When EPDCCH is associated with port 107, the transmitted block of signals is denoted as

$$\begin{bmatrix} y_{bf}(i) \\ \tilde{y}_{bf}(i) \end{bmatrix} = W_1(i) y^{(107)}(i).$$

When EPDCCH is associated with port 109, the transmitted block of signals is denoted as

$$\begin{bmatrix} y_{bf}(i) \\ \tilde{y}_{bf}(i) \end{bmatrix} = W_2(i) y^{(109)}(i).$$

B.4.5 Random beamforming for EPDCCH localized transmission (Antenna port 107, 108, 109 or 110)

EPDCCH localized transmission on antenna port 107, 108, 109 or 110 is defined by using a precoder vector $W(i)$ of size 2×1 randomly selected with the number of layers $\nu = 1$ from Table 6.3.4.2.3-1 in [4] as beamforming weights. This precoder takes as an input the signal $y^{(p)}(i)$, $i = 0, 1, \dots, M_{\text{symp}}^{\text{ap}} - 1$, for antenna port $p \in \{107, 108, 109, 110\}$, with $M_{\text{symp}}^{\text{ap}}$ the number of modulation symbols including the user-specific reference symbols (DMRS), and generates a

block of signals $y_{bf}(i) = [y_{bf}(i) \ \tilde{y}_{bf}(i)]^T$ the elements of which are to be mapped onto the same physical RE but transmitted on different antenna elements:

$$\begin{bmatrix} y_{bf}(i) \\ \tilde{y}_{bf}(i) \end{bmatrix} = W(i)y^{(p)}(i).$$

B.5 Interference models for enhanced performance requirements Type-A

This clause provides a description for the modelling of interfering cell transmissions for enhanced performance requirements Type-A including: definition of dominant interferer proportion, transmission mode 3, 4 and 9 type of interference modelling.

B.5.1 Dominant interferer proportion

Each interfering cell involved in enhanced performance requirements Type-A is characterized by its associated dominant interferer proportion (DIP) value:

$$DIP_i = \frac{\hat{I}_{or(i+1)}}{N_{oc}'}$$

where is $\hat{I}_{or(i+1)}$ is the average received power spectral density from the i -th strongest interfering cell involved in the requirement scenario ($\hat{I}_{or(1)}$ is assumed to be the power spectral density associated with the serving cell) and

$N_{oc}' = \sum_{j=2}^N \hat{I}_{or(j)} + N_{oc}$ where N_{oc} is the average power spectral density of a white noise source consistent with the definition provided in subclause 3.2 and N is the total number of cells involved in a given requirement scenario.

B.5.2 Transmission mode 3 interference model

This subclause provides transmission mode 3 interference modelling for each explicitly modelled interfering cell in the requirement scenario. In each subframe, each interfering cell shall transmit randomly modulated data over the entire PDSCH region and the full transmission bandwidth. Transmitted physical channels shall include PSS, SSS and PBCH.

For each subframe and each CQI subband as defined in subclause 7.2 of [6], a transmission rank shall be randomly determined independently from other CQI subbands as well as other interfering cells. Probabilities of occurrence of each possible transmission rank are as specified in the requirement scenario.

For rank-1 transmission over a subband, precoding for transmit diversity for the number of antenna ports in the requirement scenario shall be applied to 16QAM randomly modulated layer symbols, as specified in subclause 6.3.4.3 of [4].

For rank-2 transmission over a subband, precoding for spatial multiplexing with large delay CDD over two layers for the number of antenna ports in the requirement scenario shall be applied to 16QAM randomly modulated layer symbols, as specified in subclause 6.3.4.2.2 of [4].

For unallocated REs in the control region, precoding for transmit diversity for the number of antenna ports in the requirement scenario shall be applied to QPSK randomly modulated layer symbols, as specified in subclause 6.3.4.3 of [4]. The EPRE ratio for these REs shall be as defined for PDCCH in Annex C.3.2.

B.5.3 Transmission mode 4 interference model

This subclause provides transmission mode 4 interference modelling for each explicitly modelled interfering cell in the requirement scenario. In each subframe, each interfering cell shall transmit randomly modulated data over the entire PDSCH region and the full transmission bandwidth. Transmitted physical channels shall include PSS, SSS and PBCH.

For each subframe and each CQI subband as defined in subclause 7.2 of [6], a transmission rank shall be randomly determined independently from other CQI subbands as well as other interfering cells. Probabilities of occurrence of each possible transmission rank are as specified in the requirement scenario.

For each subframe and CQI subband, a precoding matrix for the number of layers ν associated to the selected rank shall be selected randomly from Table 6.3.4.2.3-1 of [4]. Note that codebook index 0 shall be excluded from random precoder selection when the number of layers is $\nu = 2$.

Precoding for spatial multiplexing with cell-specific reference signals for the number of antenna ports in the requirement scenario shall be applied to 16QAM randomly modulated layer symbols, as specified in subclause 6.3.4.2.1 of [4] with the selected precoding matrices for each subframe and each CQI subband.

For unallocated REs in the control region, precoding for transmit diversity for the number of antenna ports in the requirement scenario shall be applied to QPSK randomly modulated layer symbols, as specified in subclause 6.3.4.3 of [4]. The EPRE ratio for these REs shall be as defined for PDCCH in Annex C.3.2.

B.5.4 Transmission mode 9 interference model

This subclause provides transmission mode 9 interference modelling for each explicitly modelled interfering cell in the requirement scenario. In each subframe, each interfering cell shall transmit randomly modulated data over the entire PDSCH region and the full transmission bandwidth. Transmitted physical channels shall include PSS, SSS and PBCH.

For each subframe and each CQI subband as defined in subclause 7.2 of [6], a transmission rank shall be randomly determined independently from other CQI subbands as well as other interfering cells. Probabilities of occurrence of each possible transmission rank are as specified in the requirement scenario.

For each subframe and each CQI subband, a precoding matrix for the number of layers ν associated to the selected rank shall be selected randomly from Table 6.3.4.2.3-2 of [4].

The generic beamforming model in subclause B.4.3 shall be applied assuming cell-specific reference signals and CSI reference signals as specified in the requirement scenario. Random precoding with selected rank and precoding matrices for each subframe and each CQI subband shall be applied to 16QAM randomly modulated layer symbols including the user-specific reference symbols over antenna port 7 when the rank is one and antenna ports 7, 8 when the rank is two.

For unallocated REs in the control region, precoding for transmit diversity for the number of antenna ports in the requirement scenario shall be applied to QPSK randomly modulated layer symbols, as specified in subclause 6.3.4.3 of [4]. The EPRE ratio for these REs shall be as defined for PDCCH in Annex C.3.2.

B.6 Interference models for enhanced performance requirements Type-B

This clause provides a description for the modelling of interfering cell transmissions for enhanced performance requirements Type-B including: transmission mode 2, 3, 4 and 9 type of interference modelling and a definition of the random interference model.

B.6.1 Transmission mode 2 interference model

This subclause provides transmission mode 2 interference modelling for each explicitly modelled interfering cell in the requirement scenario. In each subframe, each interfering cell shall transmit randomly modulated data over the PDSCH region as specified in subclause B.6.6. Transmitted physical channels shall include PSS, SSS and PBCH.

The MCS shall be randomly determined with probabilities of occurrence of each possible MCS as specified in subclause B.6.6.

Precoding for transmit diversity for the number of antenna ports in the requirement scenario shall be applied to the randomly modulated layer symbols, as specified in subclause 6.3.4.3 of [4].

For unallocated REs in the control region, precoding for transmit diversity for the number of antenna ports in the requirement scenario shall be applied to QPSK randomly modulated layer symbols, as specified in subclause 6.3.4.3 of [4]. The EPRE ratio for these REs shall be as defined for PDCCH in Annex C.3.2.

B.6.2 Transmission mode 3 interference model

This subclause provides transmission mode 3 interference modelling for each explicitly modelled interfering cell in the requirement scenario. In each subframe, each interfering cell shall transmit randomly modulated data over the PDSCH region as specified in subclause B.6.6. Transmitted physical channels shall include PSS, SSS and PBCH.

The transmission rank shall be randomly determined for each user defined in section B.6.6 with probabilities of occurrence of each possible transmission rank as specified in subclause B.6.6.

The MCS shall be randomly determined with probabilities of occurrence of each possible MCS as specified in subclause B.6.6.

For rank-1 transmission, precoding for transmit diversity for the number of antenna ports in the requirement scenario shall be applied to the randomly modulated layer symbols, as specified in subclause 6.3.4.3 of [4].

For rank-2 transmission, precoding for spatial multiplexing with large delay CDD over two layers for the number of antenna ports in the requirement scenario shall be applied to the randomly modulated layer symbols, as specified in subclause 6.3.4.2.2 of [4].

For unallocated REs in the control region, precoding for transmit diversity for the number of antenna ports in the requirement scenario shall be applied to QPSK randomly modulated layer symbols, as specified in subclause 6.3.4.3 of [4]. The EPRE ratio for these REs shall be as defined for PDCCH in Annex C.3.2.

B.6.3 Transmission mode 4 interference model

This subclause provides transmission mode 4 interference modelling for each explicitly modelled interfering cell in the requirement scenario. In each subframe, each interfering cell shall transmit randomly modulated data over the PDSCH region as specified in subclause B.6.6. Transmitted physical channels shall include PSS, SSS and PBCH.

The transmission rank shall be randomly determined with probabilities of occurrence of each possible transmission rank as specified in subclause B.6.6.

The MCS shall be randomly determined with probabilities of occurrence of each possible MCS as specified in subclause B.6.6.

For each TTI, for each user defined in B.6.6, a single precoding matrix for the number of layers ν associated to the selected rank shall be selected randomly from Table 6.3.4.2.3-1 of [4]. Note that codebook index 0 shall be excluded from random precoder selection when the number of layers is $\nu = 2$.

Precoding for spatial multiplexing with cell-specific reference signals for the number of antenna ports in the requirement scenario shall be applied to randomly modulated layer symbols, as specified in subclause 6.3.4.2.1 of [4] with the selected precoding matrices as specified in subclause B.6.6.

For unallocated REs in the control region, precoding for transmit diversity for the number of antenna ports in the requirement scenario shall be applied to QPSK randomly modulated layer symbols, as specified in subclause 6.3.4.3 of [4]. The EPRE ratio for these REs shall be as defined for PDCCH in Annex C.3.2.

B.6.4 Transmission mode 9 interference model

This subclause provides transmission mode 9 interference modelling for each explicitly modelled interfering cell in the requirement scenario. In each subframe, each interfering cell shall transmit randomly modulated data over the PDSCH region as specified in subclause B.6.6. Transmitted physical channels shall include PSS, SSS and PBCH.

The transmission rank shall be randomly determined with probabilities of occurrence of each possible transmission rank as specified in subclause B.6.6.

The MCS shall be randomly determined with probabilities of occurrence of each possible MCS as specified in subclause B.6.6.

For each TTI, for each user defined in B.6.6, a single precoding matrix for the number of layers v associated to the selected rank shall be selected randomly from Table 6.3.4.2.3-1 of [4]. Note that codebook index 0 shall be excluded from random precoder selection when the number of layers is $v = 2$.

The generic beamforming model in subclause B.4.3 shall be applied assuming cell-specific reference signals and CSI reference signals as specified in the requirement scenario. Random precoding with selected rank and precoding matrices for each subframe shall be applied to randomly modulated layer symbols including the user-specific reference symbols over antenna port 7 when the rank is one and antenna ports 7, 8 when the rank is two.

For each TTI, for each user defined in B.6.6, the scrambling ID value n_{SCID} is randomly assigned from the set of $\{0,1\}$.

For unallocated REs in the control region, precoding for transmit diversity for the number of antenna ports in the requirement scenario shall be applied to QPSK randomly modulated layer symbols, as specified in subclause 6.3.4.3 of [4]. The EPRE ratio for these REs shall be as defined for PDCCH in Annex C.3.2.

B.6.5 CRS interference model

This subclause provides for the CRS interference modelling for each explicitly modelled interfering cell in the requirement scenario. In each subframe there is no PDSCH transmitted. Transmitted physical channels shall include PSS, SSS and PBCH.

For unallocated REs in the control region, precoding for transmit diversity for the number of antenna ports in the requirement scenario shall be applied to QPSK randomly modulated layer symbols, as specified in subclause 6.3.4.3 of [4]. The EPRE ratio for these REs shall be as defined for PDCCH in Annex C.3.2.

B.6.6 Random interference model

This subclause presents the interference model which defines the resource allocation, MCS and rank for the two interference cells. The model includes approximately 10% DTX on these interference cells. Table B.6.6-1 shows the resource allocation for four users in two different configurations for each of the two interferers. Table B.6.6-2 shows the resource allocation to be used for special subframes with TM9 interference. Table B.6.6-3 shows the probabilities for the MCS and rank for these users.

Table B.6.6-1: Resource allocation for the random interference model

Resource allocation configurations Indexes	User Index	Resource allocation for random interference model				Probability
		Resource allocation type	Bitmap for resource allocation (Note 1)			
			1st field bitmap	2nd field bitmap	3rd field bitmap	
Configuration 1	User 0	1	00	0	10101000101010	50%
	User 1	1	00	0	01010101010101	
	User 2	0	01001001001001001			
	User 3	0	00100100100100100			
Configuration 2	User 0	1	00	0	10101010101010	50%
	User 1	1	00	1	01010100010101	
	User 2	0	01001001001001001			
	User 3	0	00100100100100100			

NOTE 1: The 1st, 2nd, and 3rd field bitmaps are only valid for resource allocation type 1 which was defined in [6].
 NOTE 2: The resource allocation model is used for both 1st and 2nd interfering cells and the resource allocation is independent for each interfering cell.

Table B.6.6-2: Resource allocation for the random interference model for TM9 special subframes

Resource allocation configurations Indexes	User Index	Resource allocation for random interference model				Probability
		Resource allocation type	Bitmap for resource allocation (Note 1)			
			1st field bitmap	2nd field bitmap	3rd field bitmap	
Configuration 1	User 0	1	00	0	10101000101010	50%
	User 1	1	00	0	01010101000001	
	User 2	0	01001000001001001			
	User 3	0	00100100000100100			
Configuration 2	User 0	1	00	0	10101000101010	50%
	User 1	1	00	1	01010000010101	
	User 2	0	01001000001001001			
	User 3	0	00100100000100100			

NOTE 1: The 1st, 2nd, and 3rd field bitmaps are only valid for resource allocation type 1 which was defined in [6].
 NOTE 2: The resource allocation model is used for both 1st and 2nd interfering cells and the resource allocation is independent for each interfering cell.

Table B.6.6-3 MCS and rank configuration for the random interference model

MCS probability			Rank probability	
MCS5	MCS14	MCS25	Rank 1	Rank 2
50%	25%	25%	80%	20%

NOTE 1: The MCS and rank should follow the probability indicated in the table randomly per UE per TTI.
 NOTE 2: The probabilities for MCS and rank configuration are used for both 1st and 2nd interfering cells. The MCS and rank configurations are independent for each interfering cell.

Annex C (normative): Downlink Physical Channels

C.1 General

This annex specifies the downlink physical channels that are needed for setting a connection and channels that are needed during a connection.

C.2 Set-up

Table C.2-1 describes the downlink Physical Channels that are required for connection set up.

Table C.2-1: Downlink Physical Channels required for connection set-up

Physical Channel
PBCH
SSS
PSS
PCFICH
PDCCH
EPDCCH
PHICH
PDSCH

C.3 Connection

The following clauses, describes the downlink Physical Channels that are transmitted during a connection i.e., when measurements are done.

C.3.1 Measurement of Receiver Characteristics

Table C.3.1-1 is applicable for measurements on the Receiver Characteristics (clause 7).

Table C.3.1-1: Downlink Physical Channels transmitted during a connection (FDD and TDD)

Physical Channel	EPRE Ratio
PBCH	PBCH_RA = 0 dB
	PBCH_RB = 0 dB
PSS	PSS_RA = 0 dB
SSS	SSS_RA = 0 dB
PCFICH	PCFICH_RB = 0 dB
PDCCH	PDCCH_RA = 0 dB
	PDCCH_RB = 0 dB
PDSCH	PDSCH_RA = 0 dB
	PDSCH_RB = 0 dB
OCNG	OCNG_RA = 0 dB
	OCNG_RB = 0 dB

NOTE 1: No boosting is applied.

Table C.3.1-2: Power allocation for OFDM symbols and reference signals

Parameter	Unit	Value	Note
Transmitted power spectral density I_{or}	dBm/15 kHz	Test specific	1. I_{or} shall be kept constant throughout all OFDM symbols
Cell-specific reference signal power ratio E_{RS} / I_{or}		0 dB	

C.3.2 Measurement of Performance requirements

Table C.3.2-1 is applicable for measurements in which uniform RS-to-EPRE boosting for all downlink physical channels, unless otherwise stated.

Table C.3.2-1: Downlink Physical Channels transmitted during a connection (FDD and TDD)

Physical Channel	EPRE Ratio
PBCH	PBCH_RA = $\rho_A + \sigma$
	PBCH_RB = $\rho_B + \sigma$
PSS	PSS_RA = 0 (Note 3)
SSS	SSS_RA = 0 (Note 3)
PCFICH	PCFICH_RB = $\rho_B + \sigma$
PDCCH	PDCCH_RA = $\rho_A + \sigma$
	PDCCH_RB = $\rho_B + \sigma$
EPDCCH	EPDCCH_RA = $\rho_A + \delta$
	EPDCCH_RB = $\rho_B + \delta$
PDSCH	PDSCH_RA = ρ_A
	PDSCH_RB = ρ_B
PMCH	PMCH_RA = ρ_A
	PMCH_RB = ρ_B
MBSFN RS	MBSFN_RS_RA = ρ_A
	MBSFN_RS_RB = ρ_B
OCNG	OCNG_RA = $\rho_A + \sigma$
	OCNG_RB = $\rho_B + \sigma$

NOTE 1: $\rho_A = \rho_B = 0$ dB means no RS boosting.

NOTE 2: MBSFN RS and OCNG are not defined downlink physical channels in [4].

NOTE 3: Assuming PSS and SSS transmitted on a single antenna port.

NOTE 4: ρ_A , ρ_B , σ , and δ are test specific.

Table C.3.2-2: Power allocation for OFDM symbols and reference signals

Parameter	Unit	Value	Note
Total transmitted power spectral density I_{or}	dBm/15 kHz	Test specific	1. I_{or} shall be kept constant throughout all OFDM symbols
Cell-specific reference signal power ratio E_{RS} / I_{or}		Test specific	1. Applies for antenna port p
Energy per resource element EPRE		Test specific	1. The complex-valued symbols $y^{(p)}(i)$ and $a_{k,l}^{(p)}$ defined in [4] shall conform to the given EPRE value. 2. For TM8, TM9 and TM10 the reference point for EPRE is before the precoder in Annex B.4.

C.3.3 Aggressor cell power allocation for Measurement of Performance Requirements when ABS is Configured

For the performance requirements and channel state information reporting when ABS is configured, the power allocation for the physical channels of the aggressor cell in non-ABS and ABS is listed in Table C.3.3-1.

Table C.3.3-1: Downlink physical channels transmitted in aggressor cell when ABS is configured in this cell

Physical Channel	Parameters	Unit	EPRE Ratio	
			Non-ABS	ABS
PBCH	PBCH_RA	dB	ρ_A	Note 1
	PBCH_RB	dB	ρ_B	Note 1
PSS	PSS_RA	dB	ρ_A	Note 1
SSS	SSS_RA	dB	ρ_A	Note 1
PCFICH	PCFICH_RB	dB	ρ_B	Note 1
PHICH	PHICH_RA	dB	ρ_A	Note 1
	PHICH_RB	dB	ρ_B	Note 1
PDCCH	PDCCH_RA	dB	ρ_A	Note 1
	PDCCH_RB	dB	ρ_B	Note 1
PDSCH	PDSCH_RA	dB	N/A	Note 1
	PDSCH_RB	dB	N/A	Note 1
OCNG	OCNG_RA	dB	ρ_A	Note 1
	OCNG_RB	dB	ρ_B	Note 1

Note 1: $-\infty$ dB is allocated for this channel in this test.

Table C.3.3-2: Downlink physical channels transmitted in aggressor cell when ABS is configured in this cell when the CRS assistance information is provided

Physical Channel	Parameters	Unit	EPRE Ratio	
			Non-ABS	ABS
PBCH	PBCH_RA	dB	ρ_A	ρ_A
	PBCH_RB	dB	ρ_B	ρ_B
PSS	PSS_RA	dB	ρ_A	ρ_A
SSS	SSS_RA	dB	ρ_A	ρ_A
PCFICH	PCFICH_RB	dB	ρ_B	Note 1
PHICH	PHICH_RA	dB	ρ_A	Note 1
	PHICH_RB	dB	ρ_B	Note 1
PDCCH	PDCCH_RA	dB	ρ_A	Note 1
	PDCCH_RB	dB	ρ_B	Note 1
PDSCH	PDSCH_RA	dB	N/A	Note 1
	PDSCH_RB	dB	N/A	Note 1
OCNG	OCNG_RA	dB	ρ_A	Note 1
	OCNG_RB	dB	ρ_B	Note 1

Note 1: $-\infty$ dB is allocated for this channel in this test.

C.3.4 Power Allocation for Measurement of Performance Requirements when Quasi Co-location Type B: same Cell ID

For the performance requirements related to quasi-colocation type B behaviour when transmission points share the same Cell ID, the power allocation for the physical channels of the serving cell is listed in Table C.3.4-1 and the power allocation for the physical channels of the cell transmitting PDSCH is listed in Table C.3.4-2

Table C.3.4-1: Downlink physical channels transmitted in the serving cell (TP1)

Physical Channel	EPRE Ratio
PBCH	PBCH_RA = $\rho_A + \sigma$
	PBCH_RB = $\rho_B + \sigma$
PSS	PSS_RA = 0 (Note 2)
SSS	SSS_RA = 0 (Note 2)
PDSCH	PDSCH_RA = ρ_A
	PDSCH_RB = ρ_B
PCFICH	PCFICH_RB = $\rho_B + \sigma$
PDCCH	PDCCH_RA = $\rho_A + \sigma$
	PDCCH_RB = $\rho_B + \sigma$

NOTE 1: $\rho_A = \rho_B = 0$ dB means no RS boosting.

NOTE 2: Assuming PSS and SSS transmitted on a single antenna port.

NOTE 3: ρ_A , ρ_B and σ are test specific.

Table C.3.4-2: Downlink physical channels for the transmission point transmitting PDSCH (TP2)

Physical Channel	Value
PDSCH	Test Specific

C.3.5 Simplified CA testing method

For CA tests which require more than 16 independent faders, if a test system cannot support a throughput measurement with fading on all carriers simultaneously, the simplified CA testing method shall be used.

In the simplified CA testing method, the resulting propagation channel(s) shall be generated by considering a number of independent faders needed for one carrier and connecting them to the signal of randomly chosen carrier(s). The maximum number of channel faders on the test will be less than or equal to 16. The remaining carrier(s) shall be connected without a channel fader but with AWGN. The throughput is then collected only for the carrier(s) connected to channel faders.

In the simplified CA testing method, the test shall be repeated by choosing carrier(s) excluding already chosen carrier(s) until all the carrier(s) are tested under fading conditions. All the collected throughputs from each carrier shall be compared against the reference value of the requirements.

All supported carriers shall be configured and activated during the test.

Annex D (normative): Characteristics of the interfering signal

D.1 General

When the channel band width is wider or equal to 5MHz, a modulated 5MHz full band width E-UTRA down link signal and CW signal are used as interfering signals when RF performance requirements for E-UTRA UE receiver are defined. For channel band widths below 5MHz, the band width of modulated interferer should be equal to band width of the received signal.

D.2 Interference signals

Table D.2-1 describes the modulated interferer for different channel band width options.

Table D.2-1: Description of modulated E-UTRA interferer

	Channel bandwidth					
	1.4 MHz	3 MHz	5 MHz	10 MHz	15 MHz	20 MHz
BW _{Interferer}	1.4 MHz	3 MHz	5 MHz	5 MHz	5 MHz	5 MHz
RB	6	15	25	25	25	25

Annex E (normative): Environmental conditions

E.1 General

This normative annex specifies the environmental requirements of the UE. Within these limits the requirements of the present documents shall be fulfilled.

E.2 Environmental

The requirements in this clause apply to all types of UE(s).

E.2.1 Temperature

The UE shall fulfil all the requirements in the full temperature range of:

Table E.2.1-1

+15 °C to +35 °C	for normal conditions (with relative humidity of 25 % to 75 %)
-10 °C to +55 °C	for extreme conditions (see IEC publications 68-2-1 and 68-2-2)

Outside this temperature range the UE, if powered on, shall not make ineffective use of the radio frequency spectrum. In no case shall the UE exceed the transmitted levels as defined in clause 6.2 for extreme operation.

E.2.2 Voltage

The UE shall fulfil all the requirements in the full voltage range, i.e. the voltage range between the extreme voltages.

The manufacturer shall declare the lower and higher extreme voltages and the approximate shutdown voltage. For the equipment that can be operated from one or more of the power sources listed below, the lower extreme voltage shall not be higher, and the higher extreme voltage shall not be lower than that specified below.

Table E.2.2-1

Power source	Lower extreme voltage	Higher extreme voltage	Normal conditions voltage
AC mains	0,9 * nominal	1,1 * nominal	nominal
Regulated lead acid battery	0,9 * nominal	1,3 * nominal	1,1 * nominal
Non regulated batteries:			
Leclanché	0,85 * nominal	Nominal	Nominal
Lithium	0,95 * nominal	1,1 * Nominal	1,1 * Nominal
Mercury/nickel & cadmium	0,90 * nominal		Nominal

Outside this voltage range the UE if powered on, shall not make ineffective use of the radio frequency spectrum. In no case shall the UE exceed the transmitted levels as defined in clause 6.2 for extreme operation. In particular, the UE shall inhibit all RF transmissions when the power supply voltage is below the manufacturer declared shutdown voltage.

E.2.3 Vibration

The UE shall fulfil all the requirements when vibrated at the following frequency/amplitudes.

Table E.2.3-1

Frequency	ASD (Acceleration Spectral Density) random vibration
5 Hz to 20 Hz	0,96 m ² /s ³
20 Hz to 500 Hz	0,96 m ² /s ³ at 20 Hz, thereafter -3 dB/Octave

Outside the specified frequency range the UE, if powered on, shall not make ineffective use of the radio frequency spectrum. In no case shall the UE exceed the transmitted levels as defined in TS 36.101 for extreme operation.

Annex F (normative): Transmit modulation

F.1 Measurement Point

Figure F.1-1 shows the measurement point for the unwanted emission falling into non-allocated RB(s) and the EVM for the allocated RB(s).

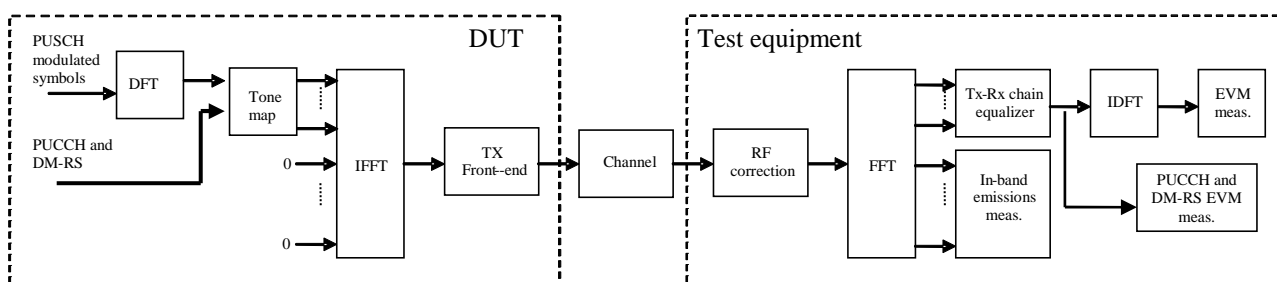

Figure F.1-1: EVM measurement points

F.2 Basic Error Vector Magnitude measurement

The EVM is the difference between the ideal waveform and the measured waveform for the allocated RB(s)

$$EVM = \sqrt{\frac{\sum_{v \in T_m} |z'(v) - i(v)|^2}{|T_m| \cdot P_0}},$$

where

T_m is a set of $|T_m|$ modulation symbols with the considered modulation scheme being active within the measurement period,

$z'(v)$ are the samples of the signal evaluated for the EVM,

$i(v)$ is the ideal signal reconstructed by the measurement equipment, and

P_0 is the average power of the ideal signal. For normalized modulation symbols P_0 is equal to 1.

The basic EVM measurement interval is defined over one slot in the time domain for PUCCH and PUSCH and over one preamble sequence for the PRACH.

F.3 Basic in-band emissions measurement

The in-band emissions are a measure of the interference falling into the non-allocated resources blocks. The in-band emission requirement is evaluated for PUCCH and PUSCH transmissions. The in-band emission requirement is not evaluated for PRACH transmissions.

The in-band emissions are measured as follows

$$Emissions_{absolute}(\Delta_{RB}) = \begin{cases} \frac{1}{|T_s|} \sum_{t \in T_s} \sum_{f_i + (12 \cdot \Delta_{RB} + 11) \Delta f}^{\max(f_{\min}, f_i + 12 \cdot \Delta_{RB} \Delta f)} |Y(t, f)|^2, \Delta_{RB} < 0 \\ \frac{1}{|T_s|} \sum_{t \in T_s} \sum_{f_h + (12 \cdot \Delta_{RB} - 11) \Delta f}^{\min(f_{\max}, f_h + 12 \cdot \Delta_{RB} \Delta f)} |Y(t, f)|^2, \Delta_{RB} > 0 \end{cases},$$

where

T_s is a set of $|T_s|$ SC-FDMA symbols with the considered modulation scheme being active within the measurement period,

Δ_{RB} is the starting frequency offset between the allocated RB and the measured non-allocated RB (e.g. $\Delta_{RB} = 1$ or $\Delta_{RB} = -1$ for the first adjacent RB),

f_{\min} (resp. f_{\max}) is the lower (resp. upper) edge of the UL system BW,

f_l and f_h are the lower and upper edge of the allocated BW, and

$Y(t, f)$ is the frequency domain signal evaluated for in-band emissions as defined in the subsection (ii)

The relative in-band emissions are, given by

$$Emissions_{relative}(\Delta_{RB}) = \frac{Emissions_{absolute}(\Delta_{RB})}{\frac{1}{|T_s|} \cdot N_{RB} \sum_{t \in T_s} \sum_{f_i}^{f_i + (12 \cdot N_{RB} - 1) \Delta f} |Y(t, f)|^2}$$

where

N_{RB} is the number of allocated RBs

The basic in-band emissions measurement interval is defined over one slot in the time domain. When the PUSCH or PUCCH transmission slot is shortened due to multiplexing with SRS, the in-band emissions measurement interval is reduced by one SC-FDMA symbol, accordingly.

In the evaluation of in-band emissions, the timing is set according to $\Delta \tilde{t} = \Delta \tilde{c}$, where sample time offsets $\Delta \tilde{t}$ and $\Delta \tilde{c}$ are defined in subclause F.4.

F.4 Modified signal under test

Implicit in the definition of EVM is an assumption that the receiver is able to compensate a number of transmitter impairments.

The PUSCH data or PRACH or Physical Sidelink Channel signal under test is modified and, in the case of PUSCH or Physical Sidelink Channel data signal, decoded according to:

$$Z'(t, f) = IDFT \left\{ \frac{FFT \left\{ z(v - \Delta\tilde{t}) \cdot e^{-j2\pi\Delta\tilde{f}v} \right\} e^{j2\pi f \Delta\tilde{t}}}{\tilde{a}(t, f) \cdot e^{j\tilde{\varphi}(t, f)}} \right\}$$

where

$z(v)$ is the time domain samples of the signal under test.

The PUCCH or PUSCH or Physical Sidelink Channel demodulation reference signal or PUCCH data signal under test is equalised and, in the case of PUCCH data signal decoded according to:

$$Z'(t, f) = \frac{FFT \left\{ z(v - \Delta\tilde{t}) \cdot e^{-j2\pi\Delta\tilde{f}v} \right\} e^{j2\pi f \Delta\tilde{t}}}{\tilde{a}(t, f) \cdot e^{j\tilde{\varphi}(t, f)}}$$

where

$z(v)$ is the time domain samples of the signal under test.

To minimize the error, the signal under test should be modified with respect to a set of parameters following the procedure explained below.

Notation:

$\Delta\tilde{t}$ is the sample timing difference between the FFT processing window in relation to nominal timing of the ideal signal.

$\Delta\tilde{f}$ is the RF frequency offset.

$\tilde{\varphi}(t, f)$ is the phase response of the TX chain.

$\tilde{a}(t, f)$ is the amplitude response of the TX chain.

In the following $\Delta\tilde{c}$ represents the middle sample of the EVM window of length W (defined in the next subsections) or the last sample of the first window half if W is even.

The EVM analyser shall

- detect the start of each slot and estimate $\Delta\tilde{t}$ and $\Delta\tilde{f}$,
- determine $\Delta\tilde{c}$ so that the EVM window of length W is centred
 - on the time interval determined by the measured cyclic prefix minus 16 samples of the considered OFDM symbol for symbol 0 for normal CP, i.e. the first 16 samples of the CP should not be taken into account for this step. In the determination of the number of excluded samples, a sampling rate of 30.72MHz was assumed. If a different sampling rate is used, the number of excluded samples is scaled linearly.
 - on the measured cyclic prefix of the considered OFDM symbol symbol for symbol 1 to 6 for normal CP and for symbol 0 to 5 for extended CP.
 - on the measured preamble cyclic prefix for the PRACH

To determine the other parameters a sample timing offset equal to $\Delta\tilde{c}$ is corrected from the signal under test. The EVM analyser shall then

- correct the RF frequency offset $\Delta\tilde{f}$ for each time slot, and
- apply an FFT of appropriate size. The chosen FFT size shall ensure that in the case of an ideal signal under test, there is no measured inter-subcarrier interference.

The carrier leakage shall be removed from the evaluated signal before calculating the EVM and the in-band emissions; however, the removed relative carrier leakage power also has to satisfy the applicable requirement.

At this stage the allocated RBs shall be separated from the non-allocated RBs. In the case of PUCCH and PUSCH EVM, the signal on the non-allocated RB(s), $Y(t, f)$, is used to evaluate the in-band emissions.

Moreover, the following procedure applies only to the signal on the allocated RB(s).

- In the case of PUCCH and PUSCH and Physical Sidelink Channel, the UL EVM analyzer shall estimate the TX chain equalizer coefficients $\tilde{a}(t, f)$ and $\tilde{\varphi}(t, f)$ used by the ZF equalizer for all subcarriers by time averaging at each signal subcarrier of the amplitude and phase of the reference and data symbols. The time-averaging length is 1 slot. This process creates an average amplitude and phase for each signal subcarrier used by the ZF equalizer. The knowledge of data modulation symbols may be required in this step because the determination of symbols by demodulation is not reliable before signal equalization.
- In the case of PRACH, the UL EVM analyzer shall estimate the TX chain coefficients $\tilde{a}(t)$ and $\tilde{\varphi}(t)$ used for phase and amplitude correction and are selected so as to minimize the resulting EVM. The TX chain coefficients are not dependent on frequency, i.e. $\tilde{a}(t, f) = \tilde{a}(t)$ and $\tilde{\varphi}(t, f) = \tilde{\varphi}(t)$. The TX chain coefficients are chosen independently for each preamble transmission and for each $\Delta\tilde{t}$.

At this stage estimates of $\Delta\tilde{f}$, $\tilde{a}(t, f)$, $\tilde{\varphi}(t, f)$ and $\Delta\tilde{c}$ are available. $\Delta\tilde{t}$ is one of the extremities of the window W , i.e. $\Delta\tilde{t}$ can be $\Delta\tilde{c} + \alpha - \left\lfloor \frac{W}{2} \right\rfloor$ or $\Delta\tilde{c} + \left\lfloor \frac{W}{2} \right\rfloor$, where $\alpha = 0$ if W is odd and $\alpha = 1$ if W is even. The EVM analyser shall then

- calculate EVM_l with $\Delta\tilde{t}$ set to $\Delta\tilde{c} + \alpha - \left\lfloor \frac{W}{2} \right\rfloor$,
- calculate EVM_h with $\Delta\tilde{t}$ set to $\Delta\tilde{c} + \left\lfloor \frac{W}{2} \right\rfloor$.

F.5 Window length

F.5.1 Timing offset

As a result of using a cyclic prefix, there is a range of $\Delta\tilde{t}$, which, at least in the case of perfect Tx signal quality, would give close to minimum error vector magnitude. As a first order approximation, that range should be equal to the length of the cyclic prefix. Any time domain windowing or FIR pulse shaping applied by the transmitter reduces the $\Delta\tilde{t}$ range within which the error vector is close to its minimum.

F.5.2 Window length

The window length W affects the measured EVM, and is expressed as a function of the configured cyclic prefix length. In the case where equalization is present, as with frequency domain EVM computation, the effect of FIR is reduced. This is because the equalization can correct most of the linear distortion introduced by the FIR. However, the time domain windowing effect can't be removed.

F.5.3 Window length for normal CP

The table below specifies the EVM window length at channel bandwidths 1.4, 3, 5, 10, 15, 20 MHz, for normal CP. The nominal window length for 3 MHz is rounded down one sample to allow the window to be centered on the symbol.

Table F.5.3-1 EVM window length for normal CP

Channel Bandwidth MHz	Cyclic prefix length ¹ N_{cp} for symbol 0	Cyclic prefix length ¹ N_{cp} for symbols 1 to 6	Nominal FFT size	Cyclic prefix for symbols 1 to 6 in FFT samples	EVM window length W in FFT samples	Ratio of W to CP for symbols 1 to 6 ²
1.4	160	144	128	9	5	55.6
3			256	18	12	66.7
5			512	36	32	88.9
10			1024	72	66	91.7
15			1536	108	102	94.4
20			2048	144	136	94.4

Note 1: The unit is number of samples, sampling rate of 30.72MHz is assumed.
Note 2: These percentages are informative and apply to symbols 1 through 6. Symbol 0 has a longer CP and therefore a lower percentage.

F.5.4 Window length for Extended CP

The table below specifies the EVM window length at channel bandwidths 1.4, 3, 5, 10, 15, 20 MHz, for extended CP. The nominal window lengths for 3 MHz and 15 MHz are rounded down one sample to allow the window to be centered on the symbol.

Table F.5.4-1 EVM window length for extended CP

Channel Bandwidth MHz	Cyclic prefix length ¹ N_{cp}	Nominal FFT size	Cyclic prefix in FFT samples	EVM window length W in FFT samples	Ratio of W to CP ²
1.4	512	128	32	28	87.5
3		256	64	58	90.6
5		512	128	124	96.9
10		1024	256	250	97.4
15		1536	384	374	97.4
20		2048	512	504	98.4

Note 1: The unit is number of samples, sampling rate of 30.72MHz is assumed.
Note 2: These percentages are informative

F.5.5 Window length for PRACH

The table below specifies the EVM window length for PRACH preamble formats 0-4.

Table F.5.5-1 EVM window length for PRACH

Preamble format	Cyclic prefix length ¹ N_{cp}	Nominal FFT size ²	EVM window length W in FFT samples	Ratio of W to CP*
0	3168	24576	3072	96.7%
1	21024	24576	20928	99.5%
2	6240	49152	6144	98.5%
3	21024	49152	20928	99.5%
4	448	4096	432	96.4%

Note 1: The unit is number of samples, sampling rate of 30.72MHz is assumed
Note 2: The use of other FFT sizes is possible as long as appropriate scaling of the window length is applied
Note 3: These percentages are informative

F.6 Averaged EVM

The general EVM is averaged over basic EVM measurements for n slots in the time domain.

$$\overline{EVM} = \sqrt{\frac{1}{n} \sum_{i=1}^n EVM_i^2},$$

where n is

$n = 20$ for PUCCH, PUSCH, PSDCH, PSCCH, and PSSCH,

$n = 48$ for PBSCH.

The EVM requirements shall be tested against the maximum of the RMS average at the window W extremities of the EVM measurements:

Thus \overline{EVM}_l is calculated using $\Delta\tilde{t} = \Delta\tilde{t}_l$ in the expressions above and \overline{EVM}_h is calculated using $\Delta\tilde{t} = \Delta\tilde{t}_h$.

Thus we get:

$$EVM = \max(\overline{EVM}_l, \overline{EVM}_h)$$

The calculation of the EVM for the demodulation reference signal, EVM_{DMRS} , follows the same procedure as calculating the general EVM, with the exception that the modulation symbol set T_m defined in clause F.2 is restricted to symbols containing uplink demodulation reference signals.

The basic EVM_{DMRS} measurements are first averaged over 20 slots in the time domain to obtain an intermediate average \overline{EVM}_{DMRS} .

$$\overline{EVM}_{DMRS} = \sqrt{\frac{1}{20} \sum_{i=1}^{20} EVM_{DMRS,i}^2}$$

In the determination of each $EVM_{DMRS,i}$, the timing is set to $\Delta\tilde{t} = \Delta\tilde{t}_l$ if $\overline{EVM}_l > \overline{EVM}_h$, and it is set to $\Delta\tilde{t} = \Delta\tilde{t}_h$ otherwise, where \overline{EVM}_l and \overline{EVM}_h are the general average EVM values calculated in the same 20 slots over which the intermediate average \overline{EVM}_{DMRS} is calculated. Note that in some cases, the general average EVM may be calculated only for the purpose of timing selection for the demodulation reference signal EVM.

Then the results are further averaged to get the EVM for the demodulation reference signal, EVM_{DMRS} ,

$$EVM_{DMRS} = \sqrt{\frac{1}{6} \sum_{j=1}^6 \overline{EVM}_{DMRS,j}^2}$$

The PRACH EVM, EVM_{PRACH} , is averaged over two preamble sequence measurements for preamble formats 0, 1, 2, 3, and it is averaged over 10 preamble sequence measurements for preamble format 4.

The EVM requirements shall be tested against the maximum of the RMS average at the window W extremities of the EVM measurements:

Thus $\overline{EVM}_{PRACH,l}$ is calculated using $\Delta\tilde{t} = \Delta\tilde{t}_l$ and $\overline{EVM}_{PRACH,h}$ is calculated using $\Delta\tilde{t} = \Delta\tilde{t}_h$.

Thus we get:

$$EVM_{PRACH} = \max(\overline{EVM}_{PRACH,l}, \overline{EVM}_{PRACH,h})$$

F.7 Spectrum Flatness

The data shall be taken from FFT coded data symbols and the demodulation reference symbols of the allocated resource block.

Annex G (informative): Reference sensitivity level in lower SNR

This annex contains information on typical receiver sensitivity when HARQ transmission is enabled allowing operation in lower SNR regions (HARQ is disabled in conformance testing), thus representing the configuration normally used in live network operation under noise-limited conditions.

G.1 General

The reference sensitivity power level P_{SENS} with HARQ retransmission enabled (operation in lower SNR) is the minimum mean power applied to both the UE antenna ports at which the residual BLER after HARQ shall meet the requirements for the specified reference measurement channel. The residual BLER after HARQ transmission is defined as follows:

$$BLER_{\text{residual}} = 1 - \frac{A}{B}$$

A : Number of correctly decoded MAC PDUs

B : Number of transmitted MAC PDUs (Retransmitted MAC PDUs are not counted)

G.2 Typical receiver sensitivity performance (QPSK)

The residual BLER after HARQ shall be lower than 1% for the reference measurement channels as specified in Annexes G.3 (with one sided dynamic OCNG Pattern OP.1 FDD/TDD for the DL-signal as described in Annex A.5.1.1/A.5.2.1) with parameters specified in Table G.2-1 and Table G.2-2

Table G.2-1: Reference sensitivity QPSK P_{SENS}

Channel bandwidth							
E-UTRA Band	1.4 MHz (dBm)	3 MHz (dBm)	5 MHz (dBm)	10 MHz (dBm)	15 MHz (dBm)	20 MHz (dBm)	Duplex Mode
1				[-102]			FDD
2				TBD			FDD
3				TBD			FDD
4				TBD			FDD
5				TBD			FDD
6				TBD			FDD
7				TBD			FDD
8				TBD			FDD
9				TBD			FDD
10				TBD			FDD
11				TBD			FDD
12				TBD			FDD
13				TBD			FDD
14				TBD			FDD
...							
17				TBD			FDD
18				TBD			FDD
19				TBD			FDD
20				TBD			FDD
21				TBD			FDD
22				TBD			FDD
23				TBD			FDD
24				TBD			FDD
26				TBD			FDD
27				TBD			FDD
28				TBD			FDD
30				TBD			FDD
31			TBD				FDD
...							
33				[-102]			TDD
34				[-102]			TDD
35				[-102]			TDD
36				[-102]			TDD
37				[-102]			TDD
38				[-102]			TDD
39				[-102]			TDD
40				[-102]			TDD
42				[-102]			TDD
43				[-102]			TDD
44				[-102]			TDD
Note 1:	The transmitter shall be set to P_{UMAX} as defined in clause 6.2.5						
Note 2:	Reference measurement channel is G.3 with one sided dynamic OCNG Pattern OP.1 FDD/TDD as described in Annex A.5.1.1/A.5.2.1						
Note 3:	The signal power is specified per port						
Note 4:	For the UE which supports both Band 3 and Band 9 the reference sensitivity level is FFS.						
Note 5:	For the UE which supports both Band 11 and Band 21 the reference sensitivity level is FFS.						

Table G.2-2 specifies the minimum number of allocated uplink resource blocks for which the reference receive sensitivity requirement in lower SNR must be met.

Table G.2-2: Minimum uplink configuration for reference sensitivity

E-UTRA Band / Channel bandwidth / NRB / Duplex mode							
E-UTRA Band	1.4 MHz	3 MHz	5 MHz	10 MHz	15 MHz	20 MHz	Duplex Mode
1				[6] ¹			FDD
2				[6] ¹			FDD
3				[6] ¹			FDD
4				[6] ¹			FDD
5				[6] ¹			FDD
6				[6] ¹			FDD
7				[6] ¹			FDD
8				[6] ¹			FDD
9				[6] ¹			FDD
10				[6] ¹			FDD
11				[6] ¹			FDD
12				[6] ¹			FDD
13				[6] ¹			FDD
14				[6] ¹			FDD
...							
17				[6] ¹			FDD
18				[6] ¹			FDD
19				[6] ¹			FDD
20				[6] ¹			FDD
22				[6] ¹			FDD
21				[6] ¹			FDD
23				[6] ¹			FDD
24				[6] ¹			FDD
26				[6] ¹			FDD
27				[6] ¹			FDD
28				[6] ¹			FDD
30				[6] ¹			FDD
31			[5] ⁴				FDD
...							
33				50			TDD
34				50			TDD
35				50			TDD
36				50			TDD
37				50			TDD
38				50			TDD
39				50			TDD
40				50			TDD
42				50			TDD
43				50			TDD
44				50			TDD
Note 1:	The UL resource blocks shall be located as close as possible to the downlink operating band but confined within the transmission bandwidth configuration for the channel bandwidth (Table 5.6-1).						
Note 2:	For the UE which supports both Band 11 and Band 21 the minimum uplink configuration for reference sensitivity is FFS.						
Note 3:	For Band 20; in the case of 15MHz channel bandwidth, the UL resource blocks shall be located at RBstart _{_11} and in the case of 20MHz channel bandwidth, the UL resource blocks shall be located at RBstart _{_16}						
Note 4:	For Band 31; in the case of 5MHz channel bandwidth, the UL resource blocks shall be located at RBstart _{_10}						

Unless given by Table G.2-3, the minimum requirements specified in Tables G.2-1 and G.2-2 shall be verified with the network signalling value NS_01 (Table 6.2.4-1) configured.

Table G.2-3: Network Signalling Value for reference sensitivity

E-UTRA Band	Network Signalling value
2	NS_03
4	NS_03
10	NS_03
12	NS_06
13	NS_06
14	NS_06
17	NS_06
19	NS_08
21	NS_09
23	NS_03
24	NS_56
30	NS_21
35	NS_03
36	NS_03

G.3 Reference measurement channel for REFSENSE in lower SNR

Tables G.3-1 and G.3-2 are applicable for Annex G.2 (Reference sensitivity level in lower SNR).

Table G.3-1 Fixed Reference Channel for Receiver Requirements (FDD)

Parameter	Unit	Value			
Channel bandwidth	MHz			5	10
Allocated resource blocks				25	50
Subcarriers per resource block				12	12
Allocated subframes per Radio Frame				9	9
Modulation				QPSK	QPSK
Target Coding Rate				1/3	1/3
Number of HARQ Processes	Processes			8	8
Maximum number of HARQ transmissions				[4]	[4]
Information Bit Payload per Sub-Frame					
For Sub-Frames 1,2,3,4,6,7,8,9	Bits			2216	4392
For Sub-Frame 5	Bits			N/A	N/A
For Sub-Frame 0	Bits			1800	4392
Transport block CRC	Bits			24	24
Number of Code Blocks per Sub-Frame (Note 4)					
For Sub-Frames 1,2,3,4,6,7,8,9	Bits			1	1
For Sub-Frame 5	Bits			N/A	N/A
For Sub-Frame 0	Bits			1	1
Binary Channel Bits Per Sub-Frame					
For Sub-Frames 1,2,3,4,6,7,8,9	Bits			6300	13800
For Sub-Frame 5	Bits			N/A	N/A
For Sub-Frame 0	Bits			5460	12960
Max. Throughput averaged over 1 frame	kbps			1952. 8	3952. 8
UE Category				1-8	1-8
Note 1:	2 symbols allocated to PDCCH for 20 MHz, 15 MHz and 10MHz channel BW. 3 symbols allocated to PDCCH for 5 MHz and 3 MHz. 4 symbols allocated to PDCCH for 1.4 MHz				
Note 2:	Reference signal, Synchronization signals and PBCH allocated as per TS 36.211 [4]				
Note 3:	If more than one Code Block is present, an additional CRC sequence of L = 24 Bits is attached to each Code Block (otherwise L = 0 Bit)				
Note 4:	Redundancy version coding sequence is {0, 1, 2, 3} for QPSK.				

Table G.3-2 Fixed Reference Channel for Receiver Requirements (TDD)

Parameter	Unit	Value			
Channel Bandwidth	MHz			10	
Allocated resource blocks				50	
Uplink-Downlink Configuration (Note 5)				1	
Allocated subframes per Radio Frame (D+S)				4+2	
Number of HARQ Processes	Processes			7	
Maximum number of HARQ transmission				[4]	
Modulation				QPSK	
Target coding rate				1/3	
Information Bit Payload per Sub-Frame	Bits				
For Sub-Frame 4, 9				4392	
For Sub-Frame 1, 6				3240	
For Sub-Frame 5				N/A	
For Sub-Frame 0				4392	
Transport block CRC	Bits			24	
Number of Code Blocks per Sub-Frame (Note 5)					
For Sub-Frame 4, 9				1	
For Sub-Frame 1, 6				1	
For Sub-Frame 5				N/A	
For Sub-Frame 0				1	
Binary Channel Bits Per Sub-Frame	Bits				
For Sub-Frame 4, 9				13800	
For Sub-Frame 1, 6				11256	
For Sub-Frame 5				N/A	
For Sub-Frame 0				13104	
Max. Throughput averaged over 1 frame	kbps			1965.6	
UE Category				1-5	
Note 1:	For normal subframes(0,4,5,9), 2 symbols allocated to PDCCH for 20 MHz, 15 MHz and 10 MHz channel BW; 3 symbols allocated to PDCCH for 5 MHz and 3 MHz; 4 symbols allocated to PDCCH for 1.4 MHz. For special subframe (1&6), only 2 OFDM symbols are allocated to PDCCH for all BWs.				
Note 2:	For 1.4MHz, no data shall be scheduled on special subframes(1&6) to avoid problems with insufficient PDCCH performance				
Note 3:	Reference signal, Synchronization signals and PBCH allocated as per TS 36.211 [4]				
Note 4:	If more than one Code Block is present, an additional CRC sequence of L = 24 Bits is attached to each Code Block (otherwise L = 0 Bit).				
Note 5:	As per Table 4.2-2 in TS 36.211 [4]				
Note 6:	Redundancy version coding sequence is {0, 1, 2, 3} for QPSK.				

Annex H (normative): Modified MPR behavior

H.1 Indication of modified MPR behavior

This annex contains the definitions of the bits in the field *modifiedMPRbehavior* indicated in the IE UE Radio Access Capability [7] by a UE supporting an MPR or A-MPR modified in a later release of this specification.

Table H.1-1: Definitions of the bits in the field *modifiedMPRbehavior*

Index of field (bit number)	Definition (description of the supported functionality if indicator set to one)	Notes
0 (leftmost bit)	- The MPR for intra-band contiguous carrier aggregation bandwidth class C with non-contiguous resource allocation specified in Clause 6.2.3A in version 12.5.0 of this specification	- This bit shall be set to 1 by a UE supporting intra-band contiguous CA bandwidth class C
1	- The A-MPR associated with NS_05 for Band 1 in Clause 6.2.4 in version 12.10.0 of this specification.	- This bit shall be set to 1 by a UE supporting A-MPR associated to NS_05 for Band 1.
2	The A-MPR associated with NS_04 for Band 41 in Table 6.2.4-4 in version 14.1.0 of this specification.	This bit can be set to 1 by a power class 3 UE supporting A-MPR associated to NS_04 for Band 41.

Annex I (informative): Change history

Table I.1: Change History

Date	Meeting	TDoc	CR	Rev	Cat	Subject/Comment	New version
11-2007	R4#45	R4-72206				TS36.101V0.1.0 approved by RAN4	
12-2007	RP#38	RP-070979				Approved version at TSG RAN #38	8.0.0
03-2008	RP#39	RP-080123	3			TS36.101 - Combined updates of E-UTRA UE requirements	8.1.0
05-2008	RP#40	RP-080325	4			TS36.101 - Combined updates of E-UTRA UE requirements	8.2.0
09-2008	RP#41	RP-080638	5r1			Addition of Ref Sens figures for 1.4MHz and 3MHz Channel bandwidths	8.3.0
09-2008	RP#41	RP-080638	7r1			Transmitter intermodulation requirements	8.3.0
09-2008	RP#41	RP-080638	10			CR for clarification of additional spurious emission requirement	8.3.0
09-2008	RP#41	RP-080638	15			Correction of In-band Blocking Requirement	8.3.0
09-2008	RP#41	RP-080638	18r1			TS36.101: CR for section 6: NS_06	8.3.0
09-2008	RP#41	RP-080638	19r1			TS36.101: CR for section 6: Tx modulation	8.3.0
09-2008	RP#41	RP-080638	20r1			TS36.101: CR for UE minimum power	8.3.0
09-2008	RP#41	RP-080638	21r1			TS36.101: CR for UE OFF power	8.3.0
09-2008	RP#41	RP-080638	24r1			TS36.101: CR for section 7: Band 13 Rx sensitivity	8.3.0
09-2008	RP#41	RP-080638	26			UE EVM Windowing	8.3.0
09-2008	RP#41	RP-080638	29			Absolute ACLR limit	8.3.0
09-2008	RP#41	RP-080731	23r2			TS36.101: CR for section 6: UE to UE co-existence	8.3.0
09-2008	RP#41	RP-080731	30			Removal of [] for UE Ref Sens figures	8.3.0
09-2008	RP#41	RP-080731	31			Correction of PA, PB definition to align with RAN1 specification	8.3.0
09-2008	RP#41	RP-080731	37r2			UE Spurious emission band UE co-existence	8.3.0
09-2008	RP#41	RP-080731	44			Definition of specified bandwidths	8.3.0
09-2008	RP#41	RP-080731	48r3			Addition of Band 17	8.3.0
09-2008	RP#41	RP-080731	50			Alignment of the UE ACS requirement	8.3.0
09-2008	RP#41	RP-080731	52r1			Frequency range for Band 12	8.3.0
09-2008	RP#41	RP-080731	54r1			Absolute power tolerance for LTE UE power control	8.3.0
09-2008	RP#41	RP-080731	55			TS36.101 section 6: Tx modulation	8.3.0
09-2008	RP#41	RP-080732	6r2			DL FRC definition for UE Receiver tests	8.3.0
09-2008	RP#41	RP-080732	46			Additional UE demodulation test cases	8.3.0
09-2008	RP#41	RP-080732	47			Updated descriptions of FRC	8.3.0
09-2008	RP#41	RP-080732	49			Definition of UE transmission gap	8.3.0
09-2008	RP#41	RP-080732	51			Clarification on High Speed train model in 36.101	8.3.0
09-2008	RP#41	RP-080732	53			Update of symbol and definitions	8.3.0
09-2008	RP#41	RP-080743	56			Addition of MIMO (4x2) and (4x4) Correlation Matrices	8.3.0
12-2008	RP#42	RP-080908	94r2			CR TX RX channel frequency separation	8.4.0
12-2008	RP#42	RP-080909	105r1			UE Maximum output power for Band 13	8.4.0
12-2008	RP#42	RP-080909	60			UL EVM equalizer definition	8.4.0
12-2008	RP#42	RP-080909	63			Correction of UE spurious emissions	8.4.0
12-2008	RP#42	RP-080909	66			Clarification for UE additional spurious emissions	8.4.0
12-2008	RP#42	RP-080909	72			Introducing ACLR requirement for coexistence with UTRA 1.6MHz channel from 36.803	8.4.0
12-2008	RP#42	RP-080909	75			Removal of [] from Section 6 transmitter characteristics	8.4.0
12-2008	RP#42	RP-080909	81			Clarification for PHS band protection	8.4.0
12-2008	RP#42	RP-080909	101			Alignment for the measurement interval for transmit signal quality	8.4.0
12-2008	RP#42	RP-080909	98r1			Maximum power	8.4.0
12-2008	RP#42	RP-080909	57r1			CR UE spectrum flatness	8.4.0
12-2008	RP#42	RP-080909	71r1			UE in-band emission	8.4.0
12-2008	RP#42	RP-080909	58r1			CR Number of TX exceptions	8.4.0
12-2008	RP#42	RP-080951	99r2			CR UE output power dynamic	8.4.0
12-2008	RP#42	RP-080951	79r1			LTE UE transmitter intermodulation	8.4.0
12-2008	RP#42	RP-080910	91			Update of Clause 8	8.4.0
12-2008	RP#42	RP-080950	106r1			Structure of Clause 9 including CSI requirements for PUCCH mode 1-0	8.4.0
12-2008	RP#42	RP-080911	59			CR UE ACS test frequency offset	8.4.0
12-2008	RP#42	RP-080911	65			Correction of spurious response parameters	8.4.0
12-2008	RP#42	RP-080911	80			Removal of LTE UE narrowband intermodulation	8.4.0

12-2008	RP#42	RP-080911	90r1		Introduction of Maximum Sensitivity Degradation	8.4.0
12-2008	RP#42	RP-080911	103		Removal of [] from Section 7 Receiver characteristic	8.4.0
12-2008	RP#42	RP-080912	62		Alignment of TB size n Ref Meas channel for RX characteristics	8.4.0
12-2008	RP#42	RP-080912	78		TDD Reference Measurement channel for RX characteristics	8.4.0
12-2008	RP#42	RP-080912	73r1		Addition of 64QAM DL referenbce measurement channel	8.4.0
12-2008	RP#42	RP-080912	74r1		Addition of UL Reference Measurement Channels	8.4.0
12-2008	RP#42	RP-080912	104		Reference measurement channels for PDSCH performance requirements (TDD)	8.4.0
12-2008	RP#42	RP-080913	68		MIMO Correlation Matrix Corrections	8.4.0
12-2008	RP#42	RP-080915	67		Correction to the figure with the Transmission Bandwidth configuration	8.4.0
12-2008	RP#42	RP-080916	77		Modification to EARFCN	8.4.0
12-2008	RP#42	RP-080917	85r1		New Clause 5 outline	8.4.0
12-2008	RP#42	RP-080919	102		Introduction of Bands 12 and 17 in 36.101	8.4.0
12-2008	RP#42	RP-080927	84r1		Clarification of HST propagation conditions	8.4.0
03-2009	RP#43	RP-090170	156r2		A-MPR table for NS_07	8.5.0
03-2009	RP#43	RP-090170	170		Corrections of references (References to tables and figures)	8.5.0
03-2009	RP#43	RP-090170	108		Removal of [] from Transmitter Intermodulation	8.5.0
03-2009	RP#43	RP-090170	155		E-UTRA ACLR for below 5 MHz bandwidths	8.5.0
03-2009	RP#43	RP-090170	116		Clarification of PHS band including the future plan	8.5.0
03-2009	RP#43	RP-090170	119		Spectrum emission mask for 1.4 MHz and 3 MHz bandwidths	8.5.0
03-2009	RP#43	RP-090170	120		Removal of "Out-of-synchronization handling of output power" heading	8.5.0
03-2009	RP#43	RP-090170	126		UE uplink power control	8.5.0
03-2009	RP#43	RP-090170	128		Transmission BW Configuration	8.5.0
03-2009	RP#43	RP-090170	130		Spectrum flatness	8.5.0
03-2009	RP#43	RP-090170	132r2		PUCCH EVM	8.5.0
03-2009	RP#43	RP-090170	134		UL DM-RS EVM	8.5.0
03-2009	RP#43	RP-090170	140		Removal of ACLR2bis requirements	8.5.0
03-2009	RP#43	RP-090171	113		In-band blocking	8.5.0
03-2009	RP#43	RP-090171	127		In-band blocking and sensitivity requirement for band 17	8.5.0
03-2009	RP#43	RP-090171	137r1		Wide band intermodulation	8.5.0
03-2009	RP#43	RP-090171	141		Correction of reference sensitivity power level of Band 9	8.5.0
03-2009	RP#43	RP-090172	109		AWGN level for UE DL demodulation performance tests	8.5.0
03-2009	RP#43	RP-090172	124		Update of Clause 8: additional test cases	8.5.0
03-2009	RP#43	RP-090172	139r1		Performance requirement structure for TDD PDSCH	8.5.0
03-2009	RP#43	RP-090172	142r1		Performance requirements and reference measurement channels for TDD PDSCH demodulation with UE-specific reference symbols	8.5.0
03-2009	RP#43	RP-090172	145		Number of information bits in DwPTS	8.5.0
03-2009	RP#43	RP-090172	160r1		MBSFN-Unicast demodulation test case	8.5.0
03-2009	RP#43	RP-090172	163r1		MBSFN-Unicast demodulation test case for TDD	8.5.0
03-2009	RP#43	RP-090173	162		Clarification of EARFCN for 36.101	8.5.0
03-2009	RP#43	RP-090369	110		Correction to UL Reference Measurement Channel	8.5.0
03-2009	RP#43	RP-090369	114		Addition of MIMO (4x4, medium) Correlation Matrix	8.5.0
03-2009	RP#43	RP-090369	121		Correction of 36.101 DL RMC table notes	8.5.0
03-2009	RP#43	RP-090369	125		Update of Clause 9	8.5.0
03-2009	RP#43	RP-090369	138r1		Clarification on OCNB	8.5.0
03-2009	RP#43	RP-090369	161		CQI reference measurement channels	8.5.0
03-2009	RP#43	RP-090369	164		PUCCH 1-1 Static Test Case	8.5.0
03-2009	RP#43	RP-090369	111		Reference Measurement Channel for TDD	8.5.0
03-2009	RP#44				Editorial correction in Table 6.2.4-1	8.5.1
05-2009	RP#44	RP-090540	167		Boundary between E-UTRA fOOB and spurious emission domain for 1.4 MHz and 3 MHz bandwidths. (Technically Endorsed CR in R4-50bis - R4-091205)	8.6.0
05-2009	RP#44	RP-090540	168		EARFCN correction for TDD DL bands. (Technically Endorsed CR in R4-50bis - R4-091206)	8.6.0
05-2009	RP#44	RP-090540	169		Editorial correction to in-band blocking table. (Technically	8.6.0

					Endorsed CR in R4-50bis - R4-091238)	
05-2009	RP#44	RP-090540	171		CR PRACH EVM. (Technically Endorsed CR in R4-50bis - R4-091308)	8.6.0
05-2009	RP#44	RP-090540	172		CR EVM correction. (Technically Endorsed CR in R4-50bis - R4-091309)	8.6.0
05-2009	RP#44	RP-090540	177		CR power control accuracy. (Technically Endorsed CR in R4-50bis - R4-091418)	8.6.0
05-2009	RP#44	RP-090540	179		Correction of SRS requirements. (Technically Endorsed CR in R4-50bis - R4-091426)	8.6.0
05-2009	RP#44	RP-090540	186		Clarification for EVM. (Technically Endorsed CR in R4-50bis - R4-091512)	8.6.0
05-2009	RP#44	RP-090540	187		Removal of [] from band 17 Refsens values and ACS offset frequencies	8.6.0
05-2009	RP#44	RP-090540	191		Completion of band17 requirements	8.6.0
05-2009	RP#44	RP-090540	192		Removal of 1.4 MHz and 3 MHz bandwidths from bands 13, 14 and 17.	8.6.0
05-2009	RP#44	RP-090540	223		CR: 64 QAM EVM	8.6.0
05-2009	RP#44	RP-090540	201		CR In-band emissions	8.6.0
05-2009	RP#44	RP-090540	203		CR EVM exclusion period	8.6.0
05-2009	RP#44	RP-090540	204		CR In-band emissions timing	8.6.0
05-2009	RP#44	RP-090540	206		CR Minimum Rx exceptions	8.6.0
05-2009	RP#44	RP-090540	207		CR UL DM-RS EVM	8.6.0
05-2009	RP#44	RP-090540	218r1		A-MPR table for NS_07	8.6.0
05-2009	RP#44	RP-090540	205r1		CR In-band emissions in shortened subframes	8.6.0
05-2009	RP#44	RP-090540	200r1		CR PUCCH EVM	8.6.0
05-2009	RP#44	RP-090540	178r2		No additional emission mask indication. (Technically Endorsed CR in R4-50bis - R4-091421)	8.6.0
05-2009	RP#44	RP-090540	220r1		Spectrum emission requirements for band 13	8.6.0
05-2009	RP#44	RP-090540	197r2		CR on aggregate power tolerance	8.6.0
05-2009	RP#44	RP-090540	196r2		CR: Rx IP2 performance	8.6.0
05-2009	RP#44	RP-090541	198r1		Maximum output power relaxation	8.6.0
05-2009	RP#44	RP-090542	166		Update of performance requirement for TDD PDSCH with MBSFN configuration. (Technically Endorsed CR in R4-50bis - R4-091180)	8.6.0
05-2009	RP#44	RP-090542	175		Adding AWGN levels for some TDD DL performance requirements. (Technically Endorsed CR in R4-50bis - R4-091406)	8.6.0
05-2009	RP#44	RP-090542	182		OCNG Patterns for Single Resource Block FRC Requirements. (Technically Endorsed CR in R4-50bis - R4-091504)	8.6.0
05-2009	RP#44	RP-090542	170r1		Update of Clause 8: PHICH and PMI delay. (Technically Endorsed CR in R4-50bis - R4-091275)	8.6.0
05-2009	RP#44	RP-090543	183		Requirements for frequency-selective fading test. (Technically Endorsed CR in R4-50bis - R4-091505)	8.6.0
05-2009	RP#44	RP-090543	199		CQI requirements under AWGN conditions	8.6.0
05-2009	RP#44	RP-090543	188r1		Adaptation of UL-RMC-s for supporting more UE categories	8.6.0
05-2009	RP#44	RP-090543	193r1		Correction of the LTE UE downlink reference measurement channels	8.6.0
05-2009	RP#44	RP-090543	184r1		Requirements for frequency non-selective fading tests. (Technically Endorsed CR in R4-50bis - R4-091506)	8.6.0
05-2009	RP#44	RP-090543	185r1		Requirements for PMI reporting. (Technically Endorsed CR in R4-50bis - R4-091510)	8.6.0
05-2009	RP#44	RP-090543	221r1		Correction to DL RMC-s for Maximum input level for supporting more UE-Categories	8.6.0
05-2009	RP#44	RP-090543	216		Addition of 15 MHz and 20 MHz bandwidths into band 38	8.6.0
05-2009	RP#44	RP-090559	180		Introduction of Extended LTE800 requirements. (Technically Endorsed CR in R4-50bis - R4-091432)	9.0.0
09-2009	RP#45	RP-090826	239		A-MPR for Band 19	9.1.0
09-2009	RP#45	RP-090822	225		LTE UTRA ACLR1 centre frequency definition for 1.4 and 3 MHz BW	9.1.0
09-2009	RP#45	RP-090822	227		Harmonization of text for LTE Carrier leakage	9.1.0
09-2009	RP#45	RP-090822	229		Sensitivity requirements for Band 38 15 MHz and 20 MHz bandwidths	9.1.0
09-2009	RP#45	RP-090822	236		Operating band edge relaxation of maximum output power for Band 18 and 19	9.1.0
09-2009	RP#45	RP-090822	238		Addition of 5MHz channel bandwidth for Band 40	9.1.0
09-2009	RP#45	RP-090822	245		Removal of unnecessary requirements for 1.4 and 3 MHz bandwidths on bands 13 and 17	9.1.0
09-2009	RP#45	RP-090877	261		Correction of LTE UE ACS test parameter	9.1.0
09-2009	RP#45	RP-090877	263R1		Correction of LTE UE ACLR test parameter	9.1.0
09-2009	RP#45	RP-090877	286		Uplink power and RB allocation for receiver tests	9.1.0

09-2009	RP#45	RP-090877	320		CR Sensitivity relaxation for small BW	9.1.0
09-2009	RP#45	RP-090877	324		Correction of Band 3 spurious emission band UE co-existence	9.1.0
09-2009	RP#45	RP-090877	249R 1		CR P _{cm} definition (working assumption)	9.1.0
09-2009	RP#45	RP-090877	330		Spectrum flatness clarification	9.1.0
09-2009	RP#45	RP-090877	332		Transmit power: removal of TC and modification of REFSENS note	9.1.0
09-2009	RP#45	RP-090877	282R 1		Additional SRS relative power requirement and update of measurement definition	9.1.0
09-2009	RP#45	RP-090877	284R 1		Power range applicable for relative tolerance	9.1.0
09-2009	RP#45	RP-090878	233		TDD UL/DL configurations for CQI reporting	9.1.0
09-2009	RP#45	RP-090878	235		Further clarification on CQI test configurations	9.1.0
09-2009	RP#45	RP-090878	243		Corrections to UL- and DL-RMC-s	9.1.0
09-2009	RP#45	RP-090878	247		Reference measurement channel for multiple PMI requirements	9.1.0
09-2009	RP#45	RP-090878	290		CQI reporting test for a scenario with frequency-selective interference	9.1.0
09-2009	RP#45	RP-090878	265R 2		CQI reference measurement channels	9.1.0
09-2009	RP#45	RP-090878	321R 1		CR RI Test	9.1.0
09-2009	RP#45	RP-090875	231		Correction of parameters for demodulation performance requirement	9.1.0
09-2009	RP#45	RP-090875	241R 1		UE categories for performance tests and correction to RMC references	9.1.0
09-2009	RP#45	RP-090875	333		Clarification of \hat{E}_s definition in the demodulation requirement	9.1.0
09-2009	RP#45	RP-090875	326		Editorial corrections and updates to PHICH PBCH test cases.	9.1.0
09-2009	RP#45	RP-090875	259R 3		Test case numbering in section 8 Performance tests	9.1.0
12-2009	RP-46	RP-091264	335		Test case numbering in TDD PDSCH performance test (Technically endorsed at RAN 4 52bis in R4-093523)	9.2.0
12-2009	RP-46	RP-091261	337		Adding beamforming model for user-specific reference signal (Technically endorsed at RAN 4 52bis in R4-093525)	9.2.0
12-2009	RP-46	RP-091263	339R 1		Adding redundancy sequences to PMI test (Technically endorsed at RAN 4 52bis in R4-093581)	9.2.0
12-2009	RP-46	RP-091264	341		Throughput value correction at FRC for Maximum input level (Technically endorsed at RAN 4 52bis in R4-093660)	9.2.0
12-2009	RP-46	RP-091261	343		Correction to the modulated E-UTRA interferer (Technically endorsed at RAN 4 52bis in R4-093662)	9.2.0
12-2009	RP-46	RP-091264	345R 1		OCNG: Patterns and present use in tests (Technically endorsed at RAN 4 52bis in R4-093664)	9.2.0
12-2009	RP-46	RP-091264	347		OCNG: Use in receiver and performance tests (Technically endorsed at RAN 4 52bis in R4-093666)	9.2.0
12-2009	RP-46	RP-091263	349		Miscellaneous corrections on CSI requirements (Technically endorsed at RAN 4 52bis in R4-093676)	9.2.0
12-2009	RP-46	RP-091261	351		Removal of RLC modes (Technically endorsed at RAN 4 52bis in R4-093677)	9.2.0
12-2009	RP-46	RP-091261	353		CR Rx diversity requirement (Technically endorsed at RAN 4 52bis in R4-093703)	9.2.0
12-2009	RP-46	RP-091261	355		A-MPR notation in NS_07 (Technically endorsed at RAN 4 52bis in R4-093706)	9.2.0
12-2009	RP-46	RP-091263	359		Single- and multi-PMI requirements (Technically endorsed at RAN 4 52bis in R4-093846)	9.2.0
12-2009	RP-46	RP-091263	363		CQI reference measurement channel (Technically endorsed at RAN 4 52bis in R4-093970)	9.2.0
12-2009	RP-46	RP-091292	364		LTE MBSFN Channel Model (Technically endorsed at RAN 4 52bis in R4-094020)	9.2.0
12-2009	RP-46	RP-091264	367		Numbering of PDSCH (User-Specific Reference Symbols) Demodulation Tests	9.2.0
12-2009	RP-46	RP-091264	369		Numbering of PDCCH/PCFICH, PHICH, PBCH Demod Tests	9.2.0
12-2009	RP-46	RP-091261	371		Remove [] from Reference Measurement Channels in Annex A	9.2.0
12-2009	RP-46	RP-091264	373R 1		Corrections to RMC-s for Maximum input level test for low UE categories	9.2.0
12-2009	RP-46	RP-091261	377		Correction of UE-category for R.30	9.2.0
12-2009	RP-46	RP-091286	378		Introduction of Extended LTE1500 requirements for TS36.101	9.2.0
12-2009	RP-46	RP-091262	384		CR: Removal of 1.4 MHz and 3 MHz channel bandwidths from additional spurious emissions requirements for Band 1 PHS protection	9.2.0
12-2009	RP-46	RP-091262	386R 3		Clarification of measurement conditions of spurious emission requirements at the edge of spurious domain	9.2.0
12-2009	RP-46	RP-091262	390		Spurious emission table correction for TDD bands 33 and 38.	9.2.0
12-2009	RP-46	RP-091262	392R 2		36.101 Symbols and abbreviations for P _{cm}	9.2.0

12-2009	RP-46	RP-091262	394		UTRA ACLR1 requirement definition for 1.4 and 3 MHz BW completed	9.2.0
12-2009	RP-46	RP-091263	396		Introduction of the ACK/NACK feedback modes for TDD requirements	9.2.0
12-2009	RP-46	RP-091262	404R3		CR Power control exception R8	9.2.0
12-2009	RP-46	RP-091262	416R1		Relative power tolerance: special case for receiver tests	9.2.0
12-2009	RP-46	RP-091263	420R1		CSI reporting: test configuration for CQI fading requirements	9.2.0
12-2009	RP-46	RP-091284	421R1		Inclusion of Band 20 UE RF parameters	9.2.0
12-2009	RP-46	RP-091264	425		Editorial corrections and updates to Clause 8.2.1 FDD demodulation test cases	9.2.0
12-2009	RP-46	RP-091262	427		CR: time mask	9.2.0
12-2009	RP-46	RP-091264	430		Correction of the payload size for PDCCH/PCFICH performance requirements	9.2.0
12-2009	RP-46	RP-091263	432		Transport format and test point updates to RI reporting test cases	9.2.0
12-2009	RP-46	RP-091263	434		Transport format and test setup updates to frequency-selective interference CQI tests	9.2.0
12-2009	RP-46	RP-091263	436		CR RI reporting configuration in PUCCH 1-1 test	9.2.0
12-2009	RP-46	RP-091261	438		Addition of R.11-1 TDD references	9.2.0
12-2009	RP-46	RP-091292	439		Performance requirements for LTE MBMS	9.2.0
12-2009	RP-46	RP-091262	442R1		In Band Emissions Requirements Correction CR	9.2.0
12-2009	RP-46	RP-091262	444R1		PCMAX definition	9.2.0
03-2010	RP-47	RP-100246	453r1		Corrections of various errors in the UE RF requirements	9.3.0
03-2010	RP-47	RP-100246	462r1		UTRA ACLR measurement bandwidths for 1.4 and 3 MHz	9.3.0
03-2010	RP-47	RP-100246	493		Band 8 Coexistence Requirement Table Correction	9.3.0
03-2010	RP-47	RP-100246	489r1		Rel 9 CR for Band 14	9.3.0
03-2010	RP-47	RP-100246	485r1		CR Band 1- PHS coexistence	9.3.0
03-2010	RP-47	RP-100247	501		Fading CQI requirements for FDD mode	9.3.0
03-2010	RP-47	RP-100247	499		CR correction to RI test	9.3.0
03-2010	RP-47	RP-100249	451		Reporting mode, Reporting Interval and Editorial corrections for demodulation	9.3.0
03-2010	RP-47	RP-100249	464r1		Corrections to 1PRB PDSCH performance test in presence of MBSFN.	9.3.0
03-2010	RP-47	RP-100249	458r1		OCNG corrections	9.3.0
03-2010	RP-47	RP-100249	467		Addition of ONCG configuration in DRS performance test	9.3.0
03-2010	RP-47	RP-100249	465r1		PDSCH performance tests for low UE categories	9.3.0
03-2010	RP-47	RP-100250	460r1		Use of OCNG in CSI tests	9.3.0
03-2010	RP-47	RP-100250	491r1		Corrections to CQI test configurations	9.3.0
03-2010	RP-47	RP-100250	469r1		Corrections of some CSI test parameters	9.3.0
03-2010	RP-47	RP-100251	456r1		TBS correction for RMC UL TDD 16QAM full allocation BW 1.4 MHz	9.3.0
03-2010	RP-47	RP-100262	449		Editorial corrections on Band 19 REFSSENS	9.3.0
03-2010	RP-47	RP-100263	470r1		Band 20 UE RF requirements	9.3.0
03-2010	RP-47	RP-100264	446r1		A-MPR for Band 21	9.3.0
03-2010	RP-47	RP-100264	448		RF requirements for UE in later releases	9.3.0
03-2010	RP-47	RP-100268	445		36.101 CR: Editorial corrections on LTE MBMS reference measurement channels	9.3.0
03-2010	RP-47	RP-100268	454		The definition of the Doppler shift for LTE MBSFN Channel Model	9.3.0
03-2010	RP-47	RP-100239	478r3		Modification of the spectral flatness requirement and some editorial corrections	9.3.0
06-2010	RP-48	RP-100619	559		Corrections of tables for Additional Spectrum Emission Mask	9.4.0
06-2010	RP-48	RP-100619	538		Correction of transient time definition for EVM requirements	9.4.0
06-2010	RP-48	RP-100619	557r2		CR on UE coexistence requirement	9.4.0
06-2010	RP-48	RP-100619	547r1		Correction of antenna configuration and beam-forming model for DRS	9.4.0
06-2010	RP-48	RP-100619	536r1		CR: Corrections on MIMO demodulation performance requirements	9.4.0
06-2010	RP-48	RP-100619	528r1		Corrections on the definition of PCMAX	9.4.0
06-2010	RP-48	RP-100619	568		Relaxation of the PDSCH demodulation requirements due to control channel errors	9.4.0
06-2010	RP-48	RP-100619	566		Correction of the UE output power definition for RX tests	9.4.0
06-2010	RP-48	RP-100620	505r1		Fading CQI requirements for TDD mode	9.4.0
06-2010	RP-48	RP-100620	521		Correction to FRC for CQI index 0	9.4.0
06-2010	RP-48	RP-100620	516r1		Correction to CQI test configuration	9.4.0
06-2010	RP-48	RP-100620	532		Correction of CQI and PMI delay configuration description for TDD	9.4.0
06-2010	RP-48	RP-100620	574		Correction to FDD and TDD CSI test configurations	9.4.0
06-2010	RP-48	RP-100620	571		Minimum requirements for Rank indicator reporting	9.4.0
06-2010	RP-48	RP-100628	563		LTE MBMS performance requirements (FDD)	9.4.0

06-2010	RP-48	RP-100628	564		LTE MBMS performance requirements (TDD)	9.4.0
06-2010	RP-48	RP-100629	553r2		Performance requirements for dual-layer beamforming	9.4.0
06-2010	RP-48	RP-100630	524r2		CR: low Category CSI requirement	9.4.0
06-2010	RP-48	RP-100630	519		Correction of FRC reference and test case numbering	9.4.0
06-2010	RP-48	RP-100630	526		Correction of carrier frequency and EARFCN of Band 21 for TS36.101	9.4.0
06-2010	RP-48	RP-100630	508r1		Addition of PDSCH TDD DRS demodulation tests for Low UE categories	9.4.0
06-2010	RP-48	RP-100630	539		Specification of minimum performance requirements for low UE category	9.4.0
06-2010	RP-48	RP-100630	569		Addition of minimum performance requirements for low UE category TDD CRS single-antenna port tests	9.4.0
06-2010	RP-48	RP-100631	549r3		Introduction of sustained downlink data-rate performance requirements	9.4.0
06-2010	RP-48	RP-100683	530r1		Band 20 Rx requirements	9.4.0
09-2010	RP-49	RP-100920	614r2		Add OCNG to MBMS requirements	9.5.0
09-2010	RP-49	RP-100916	599		Correction of PDCCH content for PHICH test	9.5.0
09-2010	RP-49	RP-100920	597r1		Beamforming model for transmission on antenna port 7/8	9.5.0
09-2010	RP-49	RP-100920	600r1		Correction of full correlation in frequency-selective CQI test	9.5.0
09-2010	RP-49	RP-100920	601		Correction on single-antenna transmission fixed reference channel	9.5.0
09-2010	RP-49	RP-100914	605		Reference sensitivity requirements for the 1.4 and 3 MHz bandwidths	9.5.0
09-2010	RP-49	RP-100920	608r1		CR for DL sustained data rate test	9.5.0
09-2010	RP-49	RP-100919	611		Correction of references in section 10 (MBMS performance requirements)	9.5.0
09-2010	RP-49	RP-100914	613		Band 13 and Band 14 spurious emission corrections	9.5.0
09-2010	RP-49	RP-100919	617r1		Rx Requirements	9.5.0
09-2010	RP-49	RP-100926	576r1		Clarification on DL-BF simulation assumptions	9.5.0
09-2010	RP-49	RP-100920	582r1		Introduction of additional Rel-9 scenarios	9.5.0
09-2010	RP-49	RP-100925	575r1		Correction to band 20 ue to ue Co-existence table	9.5.0
09-2010	RP-49	RP-100916	581r1		Test configuration corrections to CQI reporting in AWGN	9.5.0
09-2010	RP-49	RP-100916	595		Corrections to RF OCNG Pattern OP.1 and 2	9.5.0
09-2010	RP-49	RP-100919	583		Editorial corrections of 36.101	9.5.0
09-2010	RP-49	RP-100920	586		Addition of minimum performance requirements for low UE category TDD tests	9.5.0
09-2010	RP-49	RP-100914	590r1		Downlink power for receiver tests	9.5.0
09-2010	RP-49	RP-100920	591		OCNG use and power in beamforming tests	9.5.0
09-2010	RP-49	RP-100916	593		Throughput for multi-datastreams transmissions	9.5.0
09-2010	RP-49	RP-100914	588		Missing note in Additional spurious emission test with NS_07	9.5.0
09-2010	RP-49	RP-100927	596r2		CR LTE_TDD_2600_US spectrum band definition additions to TS 36.101	10.0.0
12-2010	RP-50	RP-101309	680		Demodulation performance requirements for dual-layer beamforming	10.1.0
12-2010	RP-50	RP-101325	672		Correction on the statement of TB size and subband selection in CSI tests	10.1.0
12-2010	RP-50	RP-101327	652		Correction to Band 12 frequency range	10.1.0
12-2010	RP-50	RP-101329	630		Removal of [] from TDD Rank Indicator requirements	10.1.0
12-2010	RP-50	RP-101329	635r1		Test configuration corrections to CQI TDD reporting in AWGN (Rel-10)	10.1.0
12-2010	RP-50	RP-101330	645		EVM window length for PRACH	10.1.0
12-2010	RP-50	RP-101330	649		Removal of NS signalling from TDD REFSENS tests	10.1.0
12-2010	RP-50	RP-101330	642r1		Correction of Note 4 In Table 7.3.1-1: Reference sensitivity QPSK PREFSENS	10.1.0
12-2010	RP-50	RP-101341	627		Add 20 RB UL Ref Meas channel	10.1.0
12-2010	RP-50	RP-101341	654r1		Additional in-band blocking requirement for Band 12	10.1.0
12-2010	RP-50	RP-101341	678		Further clarifications for the Sustained Downlink Data Rate Test	10.1.0
12-2010	RP-50	RP-101341	673r1		Correction on MBMS performance requirements	10.1.0
12-2010	RP-50	RP-101349	667r3		CR Removing brackets of Band 41 reference sensitivity to TS 36.101	10.1.0
12-2010	RP-50	RP-101356	666r2		Band 42 and 43 parameters for UMTS/LTE 3500 (TDD) for TS 36.101	10.1.0
12-2010	RP-50	RP-101359	646r1		CR for CA, UL-MIMO, eDL-MIMO, CPE	10.1.0
12-2010	RP-50	RP-101361	620r1		Introduction of L-band in TS 36.101	10.1.0
12-2010	RP-50	RP-101379	670r1		Correction on the PMI reporting in Multi-Layer Spatial Multiplexing performance test	10.1.0
12-2010	RP-50	RP-101380	679r1		Adding antenna configuration in CQI fading test case	10.1.0
01-2011					Clause numbering correction	10.1.1
03-2011	RP-51	RP-110359	695		Removal of E-UTRA ACLR for CA	10.2.0
03-2011	RP-51	RP-110338	699		PDCCH and PHICH performance: OCNG and power settings	10.2.0
03-2011	RP-51	RP-110336	706r1		Spurious emissions measurement uncertainty	10.2.0
03-2011	RP-51	RP-110352	707r1		REFSENSE in lower SNR	10.2.0
03-2011	RP-51	RP-110338	710		PMI performance: Power settings and precoding granularity	10.2.0
03-2011	RP-51	RP-110359	715r2		Definition of configured transmitted power for Rel-10	10.2.0

03-2011	RP-51	RP-110359	717		Introduction of requirement for adjacent intraband CA image rejection	10.2.0
03-2011	RP-51	RP-110343	719		Minimum requirements for the additional Rel-9 scenarios	10.2.0
03-2011	RP-51	RP-110343	723		Corrections to power settings for Single layer beamforming with simultaneous transmission	10.2.0
03-2011	RP-51	RP-110343	726r1		Correction to the PUSCH3-0 subband tests for Rel-10	10.2.0
03-2011	RP-51	RP-110338	730		Removing the square bracket for TS36.101	10.2.0
03-2011	RP-51	RP-110349	739		Removal of square brackets for dual-layer beamforming demodulation performance requirements	10.2.0
03-2011	RP-51	RP-110359	751		CR: Maximum input level for intra band CA	10.2.0
03-2011	RP-51	RP-110349	754r2		UE category coverage for dual-layer beamforming	10.2.0
03-2011	RP-51	RP-110343	756r1		Further clarifications for the Sustained Downlink Data Rate Test	10.2.0
03-2011	RP-51	RP-110343	759		Removal of square brackets in sustained data rate tests	10.2.0
03-2011	RP-51	RP-110337	762r1		Clarification to LTE relative power tolerance table	10.2.0
03-2011	RP-51	RP-110343	764		Introducing UE-selected subband CQI tests	10.2.0
03-2011	RP-51	RP-110343	765		Verification framework for PUSCH 2-2 and PUCCH 2-1 reporting	10.2.0
04-2011					Editorial: Spec Title correction, removal of "Draft"	10.2.1
06-2011	RP-52	RP-110804	766		Add Expanded 1900MHz Band (Band 25) in 36.101	10.3.0
06-2011	RP-52	RP-110795	768		Fixing Band 24 inclusion in TS 36.101	10.3.0
06-2011	RP-52	RP-110788	772		CR: Corrections for UE to UE co-existence requirements of Band 3	10.3.0
06-2011	RP-52	RP-110812	774		Add 2GHz S-Band (Band 23) in 36.101	10.3.0
06-2011	RP-52	RP-110789	782		CR: Band 19 A-MPR refinement	10.3.0
06-2011	RP-52	RP-110796	787		REFSENS in lower SNR	10.3.0
06-2011	RP-52	RP-110789	805		Clarification for MBMS reference signal levels	10.3.0
06-2011	RP-52	RP-110792	810		FDD MBMS performance requirements for 64QAM mode	10.3.0
06-2011	RP-52	RP-110787	814		Correction on CQI mapping index of RI test	10.3.0
06-2011	RP-52	RP-110789	824		Corrections to in-band blocking table	10.3.0
06-2011	RP-52	RP-110794	826		Correction of TDD Category 1 DRS and DMRS RMCs	10.3.0
06-2011	RP-52	RP-110794	828		TDD MBMS performance requirements for 64QAM mode	10.3.0
06-2011	RP-52	RP-110796	829		Correction of TDD RMC for Low SNR Demodulation test	10.3.0
06-2011	RP-52	RP-110796	830		Informative reference sensitivity requirements for Low SNR for TDD	10.3.0
06-2011	RP-52	RP-110787	778r1		Minor corrections to DL-RMC-s for Maximum input level	10.3.0
06-2011	RP-52	RP-110789	832		PDCCH and PHICH performance: OCNB and power settings	10.3.0
06-2011	RP-52	RP-110789	818r1		Correction on 2-X PMI test for R10	10.3.0
06-2011	RP-52	RP-110791	816r1		Addition of performance requirements for dual-layer beamforming category 1 UE test	10.3.0
06-2011	RP-52	RP-110789	834		Performance requirements for PUCCH 2-0, PUCCH 2-1 and PUSCH 2-2 tests	10.3.0
06-2011	RP-52	RP-110807	835r1		CR for UL MIMO and CA	10.3.0
09-2011	RP-53	RP-111248	862r1		Removal of unnecessary channel bandwidths from REFSENS tables	10.4.0
09-2011	RP-53	RP-111248	869r1		Clarification on BS precoding information field for RI FDD and PUCCH 2-1 PMI tests	10.4.0
09-2011	RP-53	RP-111248	872r1		CR for B14Rx requirement Rrel 10	10.4.0
09-2011	RP-53	RP-111248	890r1		CR to TS36.101: Correction on the accuracy test of CQI.	10.4.0
09-2011	RP-53	RP-111248	893		CR to TS36.101: Correction on CQI mapping index of TDD RI test	10.4.0
09-2011	RP-53	RP-111248	904		Correction of code block numbers for some RMCs	10.4.0
09-2011	RP-53	RP-111248	907		Correction to UL RMC for FDD and TDD	10.4.0
09-2011	RP-53	RP-111248	914r1		Adding codebook subset restriction for single layer closed-loop spatial multiplexing test	10.4.0
09-2011	RP-53	RP-111251	883		Sustained data rate: Correction of the ACK/NACK feedback mode	10.4.0
09-2011	RP-53	RP-111251	929		36.101 CR on MBSFN FDD requirements(R10)	10.4.0
09-2011	RP-53	RP-111251	938		TDD MBMS performance requirements for 64QAM mode	10.4.0
09-2011	RP-53	RP-111252	895		Further clarification for the dual-layer beamforming demodulation requirements	10.4.0
09-2011	RP-53	RP-111255	908r1		Introduction of Band 22	10.4.0
09-2011	RP-53	RP-111255	939		Modifications of Band 42 and 43	10.4.0
09-2011	RP-53	RP-111260	944		CR for TS 36.101 Annex B: Static channels for CQI tests	10.4.0
09-2011	RP-53	RP-111262	878r1		Correction of CSI reference channel subframe description	10.4.0
09-2011	RP-53	RP-111262	887		Correction to UL MIMO	10.4.0
09-2011	RP-53	RP-111262	926r1		Power control accuracy for intra-band carrier aggregation	10.4.0
09-2011	RP-53	RP-111262	927r1		In-band emissions requirements for intra-band carrier aggregation	10.4.0
09-2011	RP-53	RP-111262	930r1		Adding the operating band for UL-MIMO	10.4.0
09-2011	RP-53	RP-111265	848		Corrections to intra-band contiguous CA RX requirements	10.4.0
09-2011	RP-53	RP-111265	863		Intra-band contiguous CA MPR requirement refinement	10.4.0
09-2011	RP-53	RP-111265	866r1		Intra-band contiguous CA EVM	10.4.0
09-2011	RP-53	RP-111266	935		Introduction of the downlink CA demodulation requirements	10.4.0
09-2011	RP-53	RP-111266	936r1		Introduction of CA UE demodulation requirements for TDD	10.4.0
12-2011	RP-54	RP-111684	947		Corrections of UE categories of Rel-10 reference channels for RF requirements	10.5.0
12-2011	RP-54	RP-111684	948		Alternative way to define channel bandwidths per operating band for	10.5.0

12-2011	RP-54	RP-111686	949			CR for TS36.101: Adding note to the function of MPR	10.5.0
12-2011	RP-54	RP-111680	950			Clarification on applying CSI reports during rank switching in RI FDD test - Rel-10	10.5.0
12-2011	RP-54	RP-111734	953r1			Corrections for Band 42 and 43 introduction	10.5.0
12-2011	RP-54	RP-111680	956			UE spurious emissions	10.5.0
12-2011	RP-54	RP-111682	959			Add scrambling identity n_SCID for MU-MIMO test	10.5.0
12-2011	RP-54	RP-111690	960r1			P-MPR definition	10.5.0
12-2011	RP-54	RP-111693	962			Pcmax,c Computation Assumptions	10.5.0
12-2011	RP-54	RP-111733	963r1			Correction of frequency range for spurious emission requirements	10.5.0
12-2011	RP-54	RP-111680	966			General review of the reference measurement channels	10.5.0
12-2011	RP-54	RP-111691	945			Corrections of Rel-10 demodulation performance requirements This CR is only partially implemented due to confliction with CR 966	10.5.0
12-2011	RP-54	RP-111684	946			Corrections of UE categories for Rel-10 CSI requirements This CR is only partially implemented due to confliction with CR 966	10.5.0
12-2011	RP-54	RP-111691	982r2			Introduction of SDR TDD test scenario for CA UE demodulation This CR is only partially implemented due to confliction with CR 966	10.5.0
12-2011	RP-54	RP-111693	971r1			CR on Colliding CRS for non-MBSFN ABS	10.5.0
12-2011	RP-54	RP-111693	972r1			Introduction of eICIC demodulation performance requirements for FDD and TDD	10.5.0
12-2011	RP-54	RP-111686	985			Adding missing UL configuration specification in some UE receiver requirements for case of 1 CC UL capable UE	10.5.0
12-2011	RP-54	RP-111684	998			Correction and maintenance on CQI and PMI requirements (Rel-10)	10.5.0
12-2011	RP-54	RP-111735	1004			MPR for CA Multi-cluster	10.5.0
12-2011	RP-54	RP-111691	1005			CA demodulation performance requirements for LTE FDD	10.5.0
12-2011	RP-54	RP-111692	1006			CQI reporting accuracy test on frequency non-selective scheduling on eDL MIMO	10.5.0
12-2011	RP-54	RP-111692	1007			CQI reporting accuracy test on frequency-selective scheduling on eDL MIMO	10.5.0
12-2011	RP-54	RP-111692	1008			PMI reporting accuracy test for TDD on eDL MIMO	10.5.0
12-2011	RP-54	RP-111692	1009r1			CR for TS 36.101: RI performance requirements	10.5.0
12-2011	RP-54	RP-111692	1010r1			CR for TS 36.101: Introduction of static CQI tests (Rel-10)	10.5.0
03-2012	RP-55	RP-120291	1014			RF: Updates and corrections to the RMC-s related annexes (Rel-10)	10.6.0
03-2012	RP-55	RP-120300	1015r1			On eICIC ABS pattern	10.6.0
03-2012	RP-55	RP-120300	1016r1			On eICIC interference models	10.6.0
03-2012	RP-55	RP-120299	1017r1			TS36.101 CR: on eDL-MIMO channel model using cross-polarized antennas	10.6.0
03-2012	RP-55	RP-120304	1020r1			TS36.101 CR: Correction to MBMS Performance Test Parameters	10.6.0
03-2012	RP-55	RP-120303	1021			Harmonic exceptions in LTE UE to UE co-ex tests	10.6.0
03-2012	RP-55	RP-120304	1023			Unified titles for Rel-10 CSI tests	10.6.0
03-2012	RP-55	RP-120300	1033r1			Introduction of reference channel for eICIC demodulation	10.6.0
03-2012	RP-55	RP-120304	1040r1			Correction of Actual code rate for CSI RMCs	10.6.0
03-2012	RP-55	RP-120304	1041r1			Definition of synchronized operation	10.6.0
03-2012	RP-55	RP-120296	1048r1			Intra band contiguous CA Ue to Ue Co-ex	10.6.0
03-2012	RP-55	RP-120296	1049r1			REL-10 CA specification editorial consistency	10.6.0
03-2012	RP-55	RP-120299	1053			Beamforming model for TM9	10.6.0
03-2012	RP-55	RP-120296	1054			Requirement for CA demodulation with power imbalance	10.6.0
03-2012	RP-55	RP-120298	1057			Updating Band 23 duplex specifications	10.6.0
03-2012	RP-55	RP-120298	1058r1			Correcting UE Coexistence Requirements for Band 23	10.6.0
03-2012	RP-55	RP-120304	1059r1			CA demodulation performance requirements for LTE TDD	10.6.0
03-2012	RP-55	RP-120304	1061			Requirement for CA SDR FDD test scenario	10.6.0
03-2012	RP-55	RP-120293	1064r1			TS36.101 RF editorial corrections Rel 10	10.6.0
03-2012	RP-55	RP-120299	1067r1			Introduction of TM9 demodulation performance requirements	10.6.0
03-2012	RP-55	RP-120304	1071r1			Introduction of a CA demodulation test for UE soft buffer management testing	10.6.0
03-2012	RP-55	RP-120296	1072			MPR formula correction For intra-band contiguous CA Bandwidth	10.6.0

					Class C	
03-2012	RP-55	RP-120303	1077r 1		CR for 36.101: B41 REFSENS and MOP changes to accommodate single filter architecture	10.6.0
03-2012	RP-55	RP-120300	1082		TM3 tests for eICIC	10.6.0
03-2012	RP-55	RP-120300	1083r 1		Introduction of requirements of CQI reporting definition for eICIC	10.6.0
03-2012	RP-55	RP-120304	1084		eDL MIMO CSI requirements	10.6.0
03-2012	RP-55	RP-120306	1070r 1		Introduction of Band 26/XXVI to TS 36.101	11.0.0
03-2012	RP-55	RP-120310	1074		Band 41 CA CR for TS36.101, section 5	11.0.0
03-2012	RP-55	RP-120310	1075r 1		Band 41 CA CR for TS36.101, section 6	11.0.0
03-2012	RP-55	RP-120310	1076		Band 41 CA CR for TS36.101, section 7	11.0.0
06-2012	RP-56	RP-120795	1085r 2		Modulator specification tightening	11.1.0
06-2012	RP-56	RP-120777	1087r 1		Carrier aggregation Relative power tolerance, removal of TBD.	11.1.0
06-2012	RP-56	RP-120783	1089		UE spurious emissions for Band 7 and Band 38 coexistence	11.1.0
06-2012	RP-56	RP-120780	1092		Deleting square brackets in Reference Measurement Channels	11.1.0
06-2012	RP-56	RP-120779	1097		CR to TS36.101: Correction on parameters for the eDL-MIMO CQI and PMI tests	11.1.0
06-2012	RP-56	RP-120780	1098r 1		CR to TS36.101: Fixed reference channel for PDSCH demodulation performance requirements on eDL-MIMO – NOT implemented as it is based on a wrong version of the spec	11.1.0
06-2012	RP-56	RP-120774	1107		RMC correction on eDL-MIMO RI test	11.1.0
06-2012	RP-56	RP-120774	1108r 1		FRC correction on frequency selective CQI and PMI test (Rel-11)	11.1.0
06-2012	RP-56	RP-120774	1111		Correction on test point for PMI test (Rel-11)	11.1.0
06-2012	RP-56	RP-120784	1114r 1		Corrections and clarifications on eICIC demodulation test	11.1.0
06-2012	RP-56	RP-120784	1117r 1		Corrections and clarifications on eICIC CSI tests	11.1.0
06-2012	RP-56	RP-120783	1119r 1		Corrections on UE performance requirements	11.1.0
06-2012	RP-56	RP-120773	1120		Introduction of CA band combination Band1 + Band19 to TS 36.101	11.1.0
06-2012	RP-56	RP-120769	1127		Addition of ETU30 channel model	11.1.0
06-2012	RP-56	RP-120773	1140		Addition of Maximum Throughput for R.30-1 TDD RMC	11.1.0
06-2012	RP-56	RP-120779	1141		CR for 36.101: The clarification of MPR and A-MPR for CA	11.1.0
06-2012	RP-56	RP-120784	1142		Corrections for eICIC demod test case with MBSN ABS	11.1.0
06-2012	RP-56	RP-120785	1144		Removing brackets of contiguous allocation A-MPR for CA_NS_04	11.1.0
06-2012	RP-56	RP-120784	1149r 1		Introduction of PDCCH test with colliding RS on MBSFN-ABS	11.1.0
06-2012	RP-56	RP-120784	1153r 1		Some clarifications and OCNG pattern for eICIC demodulation requirements	11.1.0
06-2012	RP-56	RP-120773	1155		Introduction of TDD CA Soft Buffer Limitation	11.1.0
06-2012	RP-56	RP-120795	1156		B26 and other editorial corrections	11.1.0
06-2012	RP-56	RP-120779	1161		Corrections on CQI and PMI test	11.1.0
06-2012	RP-56	RP-120780	1163		FRC for TDD PMI test	11.1.0
06-2012	RP-56	RP-120778	1165r 1		Clean-up of UL-MIMO for TS36.101	11.1.0
06-2012	RP-56	RP-120782	1171		Removal of unnecessary references to single carrier requirements from Interband CA subclauses	11.1.0
06-2012	RP-56	RP-120781	1174		PDCCH wrong detection in receiver spurious emissions test	11.1.0
06-2012	RP-56	RP-120776	1184		Corrections to 3500 MHz	11.1.0
06-2012	RP-56	RP-120793	1189r 2		Introduction of Band 44	11.1.0
06-2012	RP-56	RP-120784	1193r 1		Target SNR setting for eICIC demodulation requirement	11.1.0
06-2012	RP-56	RP-120780	1196		Editorial simplification to CA REFSENS UL allocation table	11.1.0
06-2012	RP-56	RP-120778	1199		Correction of wrong table refernces in CA receiver tests	11.1.0
06-2012	RP-56	RP-120791	1200r 1		Introduction of e850_LB (Band 27) to TS 36.101	11.1.0
06-2012	RP-56	RP-120764	1212		Correction of PHS protection requirements for TS 36.101	11.1.0
06-2012	RP-56	RP-120793	1213r 1		Introduction of Band 28 into TS36.101	11.1.0
06-2012	RP-56	RP-120781	1215r 1		Proposed revision of subclause 4.3A for TS36.101	11.1.0
06-2012	RP-56	RP-120781	1217r 1		Proposed revision on subclause 6.3.4A for TS36.101	11.1.0
06-2012	RP-56	RP-120795	1219r 1		Aligning requirements between Band 18 and Band 26 in TS36.101	11.1.0
06-2012	RP-56	RP-120782	1221		SNR definition	11.1.0

06-2012	RP-56	RP-120778	1223		Correction of CSI configuraion for CA TM4 tests R11	11.1.0
06-2012	RP-56	RP-120773	1225		CR on CA UE receiver timing window R11	11.1.0
06-2012	RP-56	RP-120784	1226		Extension of static eCIC CQI test	11.1.0
09-2012	RP-57	RP-121294	1230		Correct Transport Block size in 9RB 16QAM Uplink Reference Measurement Channel	11.2.0
09-2012	RP-57	RP-121313	1233r1		RF: Corrections to power allocation parameters for transmission mode 8 (Rel-11)	11.2.0
09-2012	RP-57	RP-121304	1235		RF-CA: non-CA notation and applicability of test points in scenarios without and with CA operation (Rel-11)	11.2.0
09-2012	RP-57	RP-121305	1237		ACK/NACK feedback modes for FDD and TDD TM4 CA demodulation requirements (Rel-11)	11.2.0
09-2012	RP-57	RP-121305	1239		Correction of feedback mode for CA TDD demodulation requirements (resubmission of R4-63AH-0194 for Rel-11)	11.2.0
09-2012	RP-57	RP-121302	1241		ABS pattern setup for MBSFN ABS test (resubmission of R4-63AH-0204 for Rel-11)	11.2.0
09-2012	RP-57	RP-121302	1243		CR on eCIC CQI definition test (resubmission of R4-63AH-0205 for Rel-11)	11.2.0
09-2012	RP-57	RP-121302	1245		Transmission of CQI feedback and other corrections (Rel-11)	11.2.0
09-2012	RP-57	RP-121302	1247		Target SNR setting for eCIC MBSFN-ABS demodulation requirements (Rel-11)	11.2.0
09-2012	RP-57	RP-121335	1248		Introduction of CA_1_21 RF requirements into TS36.101	11.2.0
09-2012	RP-57	RP-121300	1251		Corrections of spurious emission band UE co-existence applicable in Japan	11.2.0
09-2012	RP-57	RP-121306	1253		Correction on RMC for frequency non-selective CQI test	11.2.0
09-2012	RP-57	RP-121306	1255		Requirements for the eDL-MIMO CQI test	11.2.0
09-2012	RP-57	RP-121302	1257		Clarification on PDSCH test setup under MBSFN ABS	11.2.0
09-2012	RP-57	RP-121316	1258		Update of Band 28 requirements	11.2.0
09-2012	RP-57	RP-121313	1262		Applicability of statement allowing RBW < Meas BW for spurious	11.2.0
09-2012	RP-57	RP-121298	1265		Clarification of RB allocation for DRS demodulation tests	11.2.0
09-2012	RP-57	RP-121304	1267		Removal of brackets for CA Tx	11.2.0
09-2012	RP-57	RP-121337	1268r1		TS 36.101 CR for CA_38	11.2.0
09-2012	RP-57	RP-121327	1269		Introduction of CA_B7_B20 in 36.101	11.2.0
09-2012	RP-57	RP-121313	1271		Corrections of FRC subframe allocations and other minor problems	11.2.0
09-2012	RP-57	RP-121305	1274		Introduction of requirements for TDD CA Soft Buffer Limitation	11.2.0
09-2012	RP-57	RP-121307	1276		Correction of eDL-MIMIO CSI RMC tables and references	11.2.0
09-2012	RP-57	RP-121307	1278		Correction of MIMO channel model for polarized antennas	11.2.0
09-2012	RP-57	RP-121303	1280		Addition of 15 and 20MHz Bandwidths for Band 23 to TS 36.101 (Rel-11)	11.2.0
09-2012	RP-57	RP-121334	1283r1		Add requirements for inter-band CA of B_1-18 and B_11-18 in TS36.101	11.2.0
09-2012	RP-57	RP-121304	1285r1		CR for MPR mask for multi-clustered simultaneous transmission in single CC in Rel-11	11.2.0
09-2012	RP-57	RP-121447	1288r2		Introduction of Japanese Regulatory Requirements to LTE Band 8(R11)	11.2.0
09-2012	RP-57	RP-121315	1289		CR for Band 27 MOP	11.2.0
09-2012	RP-57	RP-121315	1290		CR for Band 27 A-MPR	11.2.0
09-2012	RP-57	RP-121316	1291		CR to replace protected frequency range with new band number 27	11.2.0
09-2012	RP-57	RP-121215	1292r1		Introduction of CA band combination Band3 + Band5 to TS 36.101	11.2.0
09-2012	RP-57	RP-121306	1300r1		Requirements for eDL-MIMO RI test	11.2.0
09-2012	RP-57	RP-121306	1304		Corrections to TM9 demodulation tests	11.2.0
09-2012	RP-57	RP-121313	1306		Correction to PCFICH power parameter setting	11.2.0
09-2012	RP-57	RP-121306	1310r1		Correction on frequency non-selective CQI test	11.2.0
09-2012	RP-57	RP-121306	1313r1		eDL-MIMO CQI/PMI test	11.2.0
09-2012	RP-57	RP-121313	1316		Correction of the definition of unsynchronized operation	11.2.0
09-2012	RP-57	RP-121304	1320r1		Correction to Transmit Modulation Quality Tests for Intra-Band CA	11.2.0
09-2012	RP-57	RP-121338	1324r2		36.101 CR for LTE_CA_B7	11.2.0
09-2012	RP-57	RP-121331	1325		Introduction of CA_3_20 RF requirements into TS36.101	11.2.0
09-2012	RP-57	RP-121316	1326		A-MPR table correction for NS_18	11.2.0
09-2012	RP-57	RP-121304	1332r1		Bandwidth combination sets for intra-band and inter-band carrier aggregation	11.2.0
09-2012	RP-57	RP-121325	1339		Introduction of LTE Advanced Carrier Aggregation of Band 4 and Band 13	11.2.0
09-2012	RP-57	RP-121326	1340r1		Introduction of CA configurations CA-12A-4A and CA-17A-4A	11.2.0
09-2012	RP-57	RP-121324	1341		Introduction of CA_B3_B7 in 36.101	11.2.0

09-2012	RP-57	RP-121328	1343			Introduction of Band 2 + Band 17 inter-band CA configuration into 36.101	11.2.0
09-2012	RP-57	RP-121306	1351			FRC for TM9 FDD	11.2.0
09-2012	RP-57	RP-121295	1352			Random precoding granularity in PMI tests	11.2.0
09-2012	RP-57	RP-121302	1358			Introduction of RI test for eICIC	11.2.0
09-2012	RP-57	RP-121304	1360			Notes for deltaTib and deltaRib tables	11.2.0
09-2012	RP-57	RP-121304	1361			CR for A-MPR masks for NS_CA_1C	11.2.0
12-2012	RP-58	RP-121884	1362			Introduction of CA_3_8 RF requirements to TS 36.101	11.3.0
12-2012	RP-58	RP-121870	1363			Removal of square brackets for Band 27 in Table 5.6.1-1	11.3.0
12-2012	RP-58	RP-121861	1366			Some changes related to CA tests and overview table of DL measurement channels	11.3.0
12-2012	RP-58	RP-121860	1368			Correction of eICIC CQI tests	11.3.0
12-2012	RP-58	RP-121860	1370			Correction of eICIC demodulation tests	11.3.0
12-2012	RP-58	RP-121862	1374			Correction on CSI-RS subframe offset parameter	11.3.0
12-2012	RP-58	RP-121862	1376			Correction on FRC table in CSI test	11.3.0
12-2012	RP-58	RP-121862	1382			Correction of reference channel table for TDD eDL-MIMO RI test	11.3.0
12-2012	RP-58	RP-121850	1386			OCNG patterns for Sustained Data rate testing	11.3.0
12-2012	RP-58	RP-121867	1388r 1			Introduction of one periodic CQI test for CA deployments	11.3.0
12-2012	RP-58	RP-121894	1396			Introduction of CA_B5_B12 in 36.101	11.3.0
12-2012	RP-58	RP-121850	1401			Introducing the additional frequency bands of 5 MHz x 2 in 1.7 GHz in Japan to Band 3	11.3.0
12-2012	RP-58	RP-121887	1406r 1			Reference sensitivity for the small bandwidth of CA_4-12	11.3.0
12-2012	RP-58	RP-121860	1407			CR on eICIC RI test	11.3.0
12-2012	RP-58	RP-121862	1409			Cleaning of 36.101 Performance sections Rel-11	11.3.0
12-2012	RP-58	RP-121861	1416			Out-of-band blocking requirements for inter-band carrier aggregation	11.3.0
12-2012	RP-58	RP-121861	1418			Adding missed SNR reference values for CA soft buffer tests	11.3.0
12-2012	RP-58	RP-121890	1422			Introduction of CA_4A-5A into 36.101	11.3.0
12-2012	RP-58	RP-121867	1431			Clean up of specification R11	11.3.0
12-2012	RP-58	RP-121867	1436			Band 1 to Band 33 and Band 39 UE coexistence requirements	11.3.0
12-2012	RP-58	RP-121871	1437r 1			Editorial corrections for Band 26	11.3.0
12-2012	RP-58	RP-121896	1438			Introduction of Band 5 + Band 17 inter-band CA configuration into 36.101	11.3.0
12-2012	RP-58	RP-121862	1442			Correction of eDL-MIMO RI test and RMC table for the CSI test	11.3.0
12-2012	RP-58	RP-121861	1444			Minor correction to ceiling function example - rel11	11.3.0
12-2012	RP-58	RP-121862	1449			Correction of SNR definition	11.3.0
12-2012	RP-58	RP-121860	1450			Brackets clean up for eICIC CSI/demodulation	11.3.0
12-2012	RP-58	RP-121860	1455			CR on eICIC RI testing (Rel-11)	11.3.0
12-2012	RP-58	RP-121862	1459			Correction on FRC table	11.3.0
12-2012	RP-58	RP-121879	1461r 1			CR for LTE B14 HPUE (Power Class 1)	11.3.0
12-2012	RP-58	RP-121862	1464			Adding references to the appropriate beamforming model (Rel-11)	11.3.0
12-2012	RP-58	RP-121898	1465r 1			Introduction of CA_8_20 RF requirements into TS36.101	11.3.0
12-2012	RP-58	RP-121882	1468r 1			Introduction of inter-band CA_11-18 into TS36.101	11.3.0
12-2012	RP-58	RP-121903	1472r 1			Introduction of advanced receivers demodulation performance (FDD)	11.3.0
12-2012	RP-58	RP-121903	1473r 1			Introduction of performance requirements for verifying the receiver type for advanced receivers (FDD/TDD)	11.3.0
12-2012	RP-58	RP-121886	1474			CR to remove the square bracket of A-MPR in TS36.101	11.3.0
12-2012	RP-58	RP-121861	1476			Correction of some errors in reference sensitivity for CA in TS 36.101 (R11)	11.3.0
12-2012	RP-58	RP-121903	1480r 1			Introduction of Advanced Receivers Test Cases for TDD	11.3.0
12-2012	RP-58	RP-121901	1490r 1			Introduction of Band 29	11.3.0
12-2012	RP-58	RP-121849	1494			Low-channel Band 1 coexistence with PHS	11.3.0
12-2012	RP-58	RP-121861	1498r 1			Completion of the tables of bandwidth combinations specified for CA	11.3.0
12-2012	RP-58	RP-121861	1499r 1			Exceptions to REFSENS requirements for class A2 CA combinations	11.3.0
12-2012	RP-58	RP-121892	1500			Introduction of carrier aggregation configuration CA_4-7	11.3.0
12-2012	RP-58	RP-121870	1504			Editorial corrections to Band 27 specifications	11.3.0
12-2012	RP-58	RP-121878	1505			Band 28 AMPR for DTV protection	11.3.0
12-2012	RP-58	RP-121852	1509r 1			UE-UE coexistence between bands with small frequency separation	11.3.0
12-2012	RP-58	RP-121911	1510			Adding UE-UE Coexistence Requirement for Band 3 and Band 26	11.3.0
12-2012	RP-58	RP-121866	1513			Maintenance of Band 23 UE Coexistence	11.3.0
12-2012	RP-58	RP-121851	1515			Corrections to TM4 rank indicator Test 3	11.3.0
12-2012	RP-58	RP-121861	1517			Correction of test configurations and FRC for CA demodulation	11.3.0

					with power imbalance	
12-2012	RP-58	RP-121860	1518		Applicable OFDM symbols of Noc_2 for PDCCH/PCFICH ABS-MBSFN test cases	11.3.0
03-2013	RP-59	RP-130279	1519		OCNG patterns for Enhanced Performance Requirements Type A	11.4.0
03-2013	RP-59	RP-130277	1520		Corrections on in-band blocking for Band 29 for carrier aggregation	11.4.0
03-2013	RP-59	RP-130268	1523		Brackets removal in Rel-11 TM4 rank indicator Test 3	11.4.0
03-2013	RP-59	RP-130279	1524r1		Cleanup of Advanced Receivers requirement scenarios for demodulation and CSI (FDD/TDD)	11.4.0
03-2013	RP-59	RP-130258	1528		Corrections to CQI reporting	11.4.0
03-2013	RP-59	RP-130262	1536		Corrections for eICIC performance requirements (rel-11)	11.4.0
03-2013	RP-59	RP-130264	1539		Correction of CA power imbalance performance requirements	11.4.0
03-2013	RP-59	RP-130287	1543		Correction of a symbol for MPR in single carrier for TS 36.101(R11)	11.4.0
03-2013	RP-59	RP-130287	1544r1		Correction of some inter-band CA requirements for TS 36.101 (R11)	11.4.0
03-2013	RP-59	RP-130276	1546		Correction of contiguous allocation A-MPR for CA_NS_05	11.4.0
03-2013	RP-59	RP-130263	1547r1		Clarification of spurious emission domain for CA in TS 36.101 (R11)	11.4.0
03-2013	RP-59	RP-130264	1548		CR for CA performance requirements	11.4.0
03-2013	RP-59	RP-130284	1553r1		Introduction of downlink non-contiguous CA into REL -11 TS 36.101	11.4.0
03-2013	RP-59	RP-130263	1557		CA_1C: CA_NS_02 and CA_NS_03 A-MPR REL-11	11.4.0
03-2013	RP-59	RP-130287	1560		Editorial corrections to subclause 5	11.4.0
03-2013	RP-59	RP-130267	1562		Addition of UE Regional Requirements to Band 23 Based on New Regulatory Order in the US	11.4.0
03-2013	RP-59	RP-130272	1567		Band 26: modification of A-MPR for 'NS_15'	11.4.0
03-2013	RP-59	RP-130287	1571r1		Band 41 requirements for operation in China and Japan	11.4.0
03-2013	RP-59	RP-130260	1574		Remove [] from CSI test case parameters	11.4.0
03-2013	RP-59	RP-130287	1575		Corrections to UE co-existence	11.4.0
03-2013	RP-59	RP-130287	1579		UE-UE co-existence between Band 1 and Band 33/39	11.4.0
03-2013	RP-59	RP-130287	1580		Correction on reference to note for Band 7 and 38 co-existence	11.4.0
03-2013	RP-59	RP-130263	1584r1		Cleanup for CA UE RF requirements	11.4.0
03-2013	RP-59	RP-130263	1586		Corrections on UL configuration for CA UE receiver requirements	11.4.0
03-2013	RP-59	RP-130263	1588		Correction of Transmit modulation quality requirements for CA	11.4.0
03-2013	RP-59	RP-130268	1590		Revision of Common Test Parameters for User-specific Demodulation Tests	11.4.0
03-2013	RP-59	RP-130278	1595		Correction for a Band 27 A-MPR table	11.4.0
03-2013	RP-59	RP-130264	1597		Correction of CA CQI test setup	11.4.0
03-2013	RP-59	RP-130287	1600r1		Correction of B12 DL Specification in Table 5.5A-2	11.4.0
03-2013	RP-59	RP-130263	1602		Correction of table reference	11.4.0
06-2013	RP-60	RP-130765	1604r1		Complementary description for definition of MIMO Correlation Matrices using cross polarized antennas	11.5.0
06-2013	RP-60	RP-130763	1607		Correction of transport format parameters for CQI index 10 (15 RBs) - Rel 11	11.5.0
06-2013	RP-60	RP-130765	1610		Maintenance of Band 23 A-MPR (NS_11) in TS 36.101 (Rel-11)	11.5.0
06-2013	RP-60	RP-130770	1613		CR for 36.101 : Adding the definition of CA_NS_05 and CA_NS_06 for additional spurious emissions for CA	11.5.0
06-2013	RP-60	RP-130770	1619		CR for introducing UE TM3 demodulation performance requirements under high speed	11.5.0
06-2013	RP-60	RP-130765	1623		Correction of test parameters for eICIC performance requirements	11.5.0
06-2013	RP-60	RP-130765	1625		Correction of test parameters for eICIC CSI requirements	11.5.0
06-2013	RP-60	RP-130765	1627		Correction of resource allocation for the multiple PMI Cat 1 UE test	11.5.0
06-2013	RP-60	RP-130766	1629		Removal of note 2 from band 28	11.5.0
06-2013	RP-60	RP-130770	1641		Correction of the CSI-RS parameter configuration	11.5.0
06-2013	RP-60	RP-130770	1650r1		Addition of Band 41 for intra-band non-contiguous CA for 36.101	11.5.0
06-2013	RP-60	RP-130770	1654r1		MPR for intra-band non-contiguous CA	11.5.0
06-2013	RP-60	RP-130765	1656		Modification of configured output power to account for larger tolerance	11.5.0
06-2013	RP-60	RP-130769	1658r1		Missing symbols in the NS_15 table	11.5.0
06-2013	RP-60	RP-130766	1673		Corrections to Rx requirements for inter-band CA configurations with REFSSENS exceptions	11.5.0
06-2013	RP-60	RP-130770	1681r1		Correction for TS 36.101	11.5.0
06-2013	RP-60	RP-130763	1684		RF: Corrections to RMC-s for sustained data rate test	11.5.0
06-2013	RP-60	RP-130770	1685		Non-contiguous intraband CA channel spacing	11.5.0
06-2013	RP-60	RP-130766	1689		Carrier aggregation in multi RAT and multiple band combination	11.5.0

					terminals	
06-2013	RP-60	RP-130766	1691		Completion of out-of-band blocking requirements for inter-band CA with one UL	11.5.0
06-2013	RP-60	RP-130767	1695r 1		CR on the bandwidth coverage issue of CA demodulation performance (Rel-11)	11.5.0
06-2013	RP-60	RP-130765	1697		Correction on UE maximum output power for intra-band CA (R11)	11.5.0
06-2013	RP-60	RP-130770	1698r 1		CR for introduction of FeICIC demodulation performance requirements	11.5.0
06-2013	RP-60	RP-130770	1701		Removing bracket from CA_11A-18A requirements	11.5.0
06-2013	RP-60	RP-130767	1703		CR on the bandwidth coverage issue of CA CQI performance (Rel-11)	11.5.0
06-2013	RP-60	RP-130766	1705		Corrections to ACLR for Rel-11 CA	11.5.0
06-2013	RP-60	RP-130765	1716		Corrections to NS_11 A-MPR Table	11.5.0
06-2013	RP-60	RP-130769	1717		Corrections to NS_12 A-MPR Table	11.5.0
06-2013	RP-60	RP-130771	1532r 1		Introduction of CA 1+8 into TS36.101(Rel-12)	12.0.0
06-2013	RP-60	RP-130781	1545r 1		Introduction of LTE Advanced inter-band Carrier Aggregation of Band 3 and Band 28 to TS 36.101	12.0.0
06-2013	RP-60	RP-130785	1608r 1		Introduction of LTE Advanced inter-band Carrier Aggregation of Band 23 and Band 29 to TS 36.101	12.0.0
06-2013	RP-60	RP-130777	1642r 1		Introduction of CA B3+19 into TS36.101(Rel-12)	12.0.0
06-2013	RP-60	RP-130787	1687		Introduction of CA_4A-4A into 36.101	12.0.0
06-2013	RP-60	RP-130795	1712		Adding 5MHz CBW for B3 of Inter band CA of B3+26	12.0.0
06-2013	RP-60	RP-130775	1713r 1		Introduction of LTE Advanced Inter-Band Carrier Aggregation of Band 2 and Band 13	12.0.0
06-2013	RP-60	RP-130790	1723r 1		Introduction of the LTE 450 band to TS 36.101	12.0.0
06-2013	RP-60	RP-130791	1724r 1		Introduction of the WCS band to TS 36.101	12.0.0
06-2013	RP-60	RP-130784	1707r 1		Introduction of CA 19+21 into TS36.101(Rel-12)	12.0.0
09-2013	RP-61	RP-131300	1730r 1		36.101 CR for LTE_CA_C_B3	12.1.0
09-2013	RP-61	RP-131285	1732		CR on performance requirements of CA soft buffer management (Rel-12)	12.1.0
09-2013	RP-61	RP-131303	1733r 1		CR to introduce TM3 and TM4 test for 5MHz channel bandwidth	12.1.0
09-2013	RP-61	RP-131281	1736		CR on applicability of CA sustained data rate tests (Rel-12)	12.1.0
09-2013	RP-61	RP-131293	1739		Performance requirement for UE under EVA200	12.1.0
09-2013	RP-61	RP-131290	1743		CR for introduction of FeICIC PBCH performance requirement	12.1.0
09-2013	RP-61	RP-131290	1745		CR for introduction of FeICIC RI reporting requirements	12.1.0
09-2013	RP-61	RP-131292	1747		Beamforming model for EPDCCH test	12.1.0
09-2013	RP-61	RP-131303	1748		CR to introduce CSI tests for LTE450	12.1.0
09-2013	RP-61	RP-131303	1749		CR to extend UE category of the existing 5MHz performance requirements	12.1.0
09-2013	RP-61	RP-131281	1767		UE REFSSENS when supporting intra-band CA and inter-band CA	12.1.0
09-2013	RP-61	RP-131279	1772		Correlation matrix for high speed train demodulation scenarios (Rel-12)	12.1.0
09-2013	RP-61	RP-131280	1776		Corrections to sustained data rate test (Rel-12)	12.1.0
09-2013	RP-61	RP-131303	1781		CR to introduce a new PHICH test based on 5MHz	12.1.0
09-2013	RP-61	RP-131303	1782		CR placeholder for applicability of new 5MHz tests	12.1.0
09-2013	RP-61	RP-131303	1783r 1		CR : Proposal of applicability of new 5MHz tests	12.1.0
09-2013	RP-61	RP-131303	1784		CR: PHICH tests for 5MHz	12.1.0
09-2013	RP-61	RP-131290	1786		CR for introduction of FeICIC CQI requirements	12.1.0
09-2013	RP-61	RP-131281	1794		Clarification of multi-cluster transmission	12.1.0
09-2013	RP-61	RP-131294	1800r 1		CA UE Coexistence Table update (Release 12)	12.1.0
09-2013	RP-61	RP-131302	1802		Coexistence between Band 27 and Band 38 (Release 12)	12.1.0
09-2013	RP-61	RP-131285	1803		Additional requirement for CA_1A-18A into TS36.101	12.1.0
09-2013	RP-61	RP-131296	1804		Add requirements for CA_1A-26A into TS36.101	12.1.0
09-2013	RP-61	RP-131281	1807		Incorrect REFSSENS UL allocation for CA_1C	12.1.0
09-2013	RP-61	RP-131297	1808r 1		Introduction of CA_2A-4A into 36.101	12.1.0
09-2013	RP-61	RP-131281	1811		Contiguous intraband CA REFSSENS with one UL	12.1.0
09-2013	RP-61	RP-131281	1822		The P _{cm} clauses restructured: This CR was NOT implemented as it was based on the wrong version of the spec	12.1.0
09-2013	RP-61	RP-131298	1824		Introduction of inter-band CA Band 2+5	12.1.0
09-2013	RP-61	RP-131285	1831		MPR for intra-band non-contiguous CA	12.1.0
09-2013	RP-61	RP-131281	1832		Correction to Rel-10 A-MPR for CA_NS_04	12.1.0
09-2013	RP-61	RP-131285	1834		CR for 36.101 : Add the definition of 5+20MHz for spectrum emission mask for CA	12.1.0
09-2013	RP-61	RP-131303	1839		CR to introduce CSI tests for LTE450	12.1.0

09-2013	RP-61	RP-131293	1840			Remained Transmitter requirements for intra-band non-contiguous CA	12.1.0
09-2013	RP-61	RP-131303	1841			CR to introduce TM3 and TM4 test for 5MHz channel bandwidth	12.1.0
12-2013	RP-62	RP-131928	1847r 1			Corrections to the notes in the band UE co-existence requirements table (Rel-12)	12.2.0
12-2013	RP-62	RP-131924	1852			Clean-up of uplink reference measurement channels (Rel-12)	12.2.0
12-2013	RP-62	RP-131946	1857			Introduction of CA band combination Band2 + Band12 to TS 36.101	12.2.0
12-2013	RP-62	RP-131954	1858			Introduction of CA band combination Band12 + Band25 to TS 36.101	12.2.0
12-2013	RP-62	RP-131931	1867			CA_NS_05 Emissions	12.2.0
12-2013	RP-62	RP-131939	1869			NS signaling for CA refsens	12.2.0
12-2013	RP-62	RP-131965	1870			Introduction of CA_23A-23A RF requirements into 36.101	12.2.0
12-2013	RP-62	RP-131928	1877r 2			Intraband CA channel bandwidth combination table restructuring	12.2.0
12-2013	RP-62	RP-131940	1878			Addition of CA_3C missing UE to UE co-existence requirement and corection to SEM	12.2.0
12-2013	RP-62	RP-131959	1885			Introduction of LTE_CA_C_B27 to 36.101	12.2.0
12-2013	RP-62	RP-131939	1887			CR on correction of definition on Fraction of Maximum Throughput for CA	12.2.0
12-2013	RP-62	RP-131939	1889			CR on correction of test configurations of CA soft buffer tests	12.2.0
12-2013	RP-62	RP-131936	1893			CR for FeICIC demodulation performance requirements	12.2.0
12-2013	RP-62	RP-131936	1895r 1			CR on FeICIC PBCH performance requirement	12.2.0
12-2013	RP-62	RP-131936	1897r 1			CR on RI reporting requirement	12.2.0
12-2013	RP-62	RP-131938	1899			Beamforming model for EPDCCH localized test	12.2.0
12-2013	RP-62	RP-131938	1901			Downlink physical setup for EPDCCH test	12.2.0
12-2013	RP-62	RP-131926	1904			Correction on the UE category for eICIC CQI test	12.2.0
12-2013	RP-62	RP-131931	1906			CR for receiver type verification test of CSI-RS based advanced receivers (Rel-12)	12.2.0
12-2013	RP-62	RP-131956	1910r 1			Spurious emission band UE co-existence requirements for cross-region issue	12.2.0
12-2013	RP-62	RP-131928	1916r 2			Allowed power reductions for multiple transmissions in a subframe	12.2.0
12-2013	RP-62	RP-131967	1917r 1			The coexistence requirements between Band 39 and Band 3	12.2.0
12-2013	RP-62	RP-131967	1918r 1			The P _{cmx} clauses restructured and removal of addition of ΔT_c to P-MPR	12.2.0
12-2013	RP-62	RP-131956	1919			Configured maximum output power for multiple TAG transmission	12.2.0
12-2013	RP-62	RP-131936	1927r 1			Configured maximum output power for multiple TAG transmission	12.2.0
12-2013	RP-62	RP-131927	1934			CR on correction of FRC of power imbalance test	12.2.0
12-2013	RP-62	RP-131927	1937			UE-UE coexistence for Band 40	12.2.0
12-2013	RP-62	RP-131957	1955r 1			Introduction of LTE Advanced intra-band contiguous Carrier Aggregation in Band 23 to TS 36.101	12.2.0
12-2013	RP-62	RP-131961	1956r 1			Introduction of CA_3A-3A into TS 36.101	12.2.0
12-2013	RP-62	RP-131937	1957			CR Minimum requirement with Different Cell ID and Colliding CRS (with single NZP CSI-RS resource)	12.2.0
12-2013	RP-62	RP-131937	1958			CR Minimum requirement with Same Cell ID (with multiple NZP CSI-RS resources)	12.2.0
12-2013	RP-62	RP-131936	1962			Introduction of reference SNR-s for FeICIC demodulation performance requirements	12.2.0
12-2013	RP-62	RP-131938	1964			OCNG pattern for EPDCCH test	12.2.0
12-2013	RP-62	RP-131931	1965			CA performance requirements for TDD intra-band NC CA	12.2.0
12-2013	RP-62	RP-131958	1966r 1			CA performance requirements for TDD intra-band NC CA	12.2.0
12-2013	RP-62	RP-131939	1968			Introduction of UE TM3 demodulation performance requirements under ETU300	12.2.0

12-2013	RP-62	RP-131937	1970			Introduction of test 1-A for CoMP	12.2.0
12-2013	RP-62	RP-131939	1972			Modification of TM9 test to verify correct SNR estimation	12.2.0
12-2013	RP-62	RP-131928	1984			Correction to blocking requirements and use of Delta_RIB	12.2.0
12-2013	RP-62	RP-131950	1985			Introduction of CA band combination Band5 + Band25 to TS 36.101	12.2.0
12-2013	RP-62	RP-131939	1988r1			CR on test point clarification for CA demodulation test	12.2.0
12-2013	RP-62	RP-131937	1994			CR to Introduce fading CQI test for CoMP (TDD)	12.2.0
12-2013	RP-62	RP-131937	1996			CR to Introduce channel model for CoMP fading CQI tests	12.2.0
12-2013	RP-62	RP-131937	1998			CR to Introduce RI test for CoMP (FDD)	12.2.0
12-2013	RP-62	RP-131938	2001r1			Distributed EPDCCH Demodulation Test	12.2.0
12-2013	RP-62	RP-131938	2003r1			Localized EPDCCH Demodulation Test	12.2.0
12-2013	RP-62	RP-131938	2005r1			Localized EPDCCH Demodulation Test	12.2.0
12-2013	RP-62	RP-131937	2007			Introduction of DL CoMP FDD static CQI test	12.2.0
12-2013	RP-62	RP-131937	2009			Introduction of DL CoMP TDD static CQI test	12.2.0
12-2013	RP-62	RP-131924	2014			P-max for Band 38 to Band 7 coexistence	12.2.0
12-2013	RP-62	RP-131948	2015			Introduction of CA band combination B5 + B7 to TS 36.101	12.2.0
12-2013	RP-62	RP-131952	2017			Introduction of CA band combination B7 + B28 to TS 36.101	12.2.0
12-2013	RP-62	RP-131937	2024			Minimum requirement with Same Cell ID (with multiple NZP CSI-RS resources) TDD	12.2.0
12-2013	RP-62	RP-131937	2026			CR Minimum requirement with Different Cell ID and Colliding CRS (with single NZP CSI-RS resource) TDD	12.2.0
12-2013	RP-62	RP-131936	2028			Editorial change on FelCIC PBCH Noc setup	12.2.0
12-2013	RP-62	RP-131937	2032			Introduction of test 1-A for CoMP	12.2.0
12-2013	RP-62	RP-131931	2035r1			Correction of nominal guard bands for bandwidth classes A, B and C	12.2.0
12-2013	RP-62	RP-131937	2042			CR to Introduce RI test for CoMP (TDD)	12.2.0
12-2013	RP-62	RP-131937	2043			CR to Introduce fading CQI test for CoMP (FDD)	12.2.0
12-2013	RP-62	RP-131931	2045			Correction of TDD PCFICH/PDCCH test parameter table	12.2.0
12-2013	RP-62	RP-131939	2047			Add EVA200 to table of channel model parameters	12.2.0
12-2013	RP-62	RP-131963	2050r1			Introduction of CA_7A-7A into TS 36.101	12.2.0
12-2013	RP-62	RP-131967	2057			Band 41 deployment in Japan	12.2.0
12-2013	RP-62	RP-131926	2059			CA_1C: Correction on CA_NS_02 A-MPR table	12.2.0
12-2013	RP-62	RP-131924	2060			Simplification of Band 12/17 in-band blocking test cases	12.2.0
12-2013	RP-62	RP-131967	2064			Correction of duplicated notes on table 7.3.1A-3	12.2.0
12-2013	RP-62	RP-131938	2066			Introduction of EPDCCH TM10 localized test R-12	12.2.0
12-2013	RP-62	RP-131938	2068			Introduction of SDR test for PDSCH with EPDCCH scheduling	12.2.0
03-2014	RP-63	RP-140377	2115			Editorial Correction for TS36.101 Rel-12	12.3.0
03-2014	RP-63	RP-140371	2108			UL-DL configuration and other parameters for FelCIC TDD CQI fading test (Rel-12)	12.3.0
03-2014	RP-63	RP-140374	2097			CR on TM9 localized ePDCCH test	12.3.0
03-2014	RP-63	RP-140374	2101			CR on reference measurement channel for ePDCCH test	12.3.0
03-2014	RP-63	RP-140371	2110			CR for TS36.101 COMP demodulation requirements	12.3.0
03-2014	RP-63	RP-140371	2113			CR for Combinations of channel model parameters	12.3.0
03-2014	RP-63	RP-140374	2114			CR for EPDCCH power allocation (Rel-12)	12.3.0
03-2014	RP-63	RP-140371	2106			Cleanup of the specification for FelCIC (Rel-12)	12.3.0
03-2014	RP-63	RP-140375	2089			CR for introduction of 15MHz based single carrier and CA SDR tests in Rel-12	12.3.0

03-2014	RP-63	RP-140375	2080r 1			CR on TM3 demodulation and soft buffer management test	12.3.0
03-2014	RP-63	RP-140371	2086			CR on reference measurement channel for TM10 PDSCH demodulation test	12.3.0
03-2014	RP-63	RP-140241	2174			Introduction of 3MHz in Band 8 for CA_8_20 RF requirements into TS36.101	12.3.0
03-2014	RP-63	RP-140417	2173r 1			Addition of bandwidth combination set for CA_2A-29A and CA_4A-29A	12.3.0
03-2014	RP-63	RP-140387	2071r 1			Introduction of TDD inter-band CA_B39_B41 into 36.101	12.3.0
03-2014	RP-63	RP-140378	2069			CA_3C is adding 100RB+75RB uplink configuration for reference sensitivity	12.3.0
03-2014	RP-63	RP-140388	2070			CR for TS36.101 on CA_C_B39	12.3.0
03-2014	RP-63	RP-140386	2072			Introduction of CA band B3+B27 to TS36.101	12.3.0
03-2014	RP-63	RP-140374	2074			CR of EPDCCH localized test with TM10 QCL Type-B configuration (Rel-12)	12.3.0
03-2014	RP-63	RP-140371	2142			Clarification of contiguous and non-contiguous intra-band UE capabilities in the same band	12.3.0
03-2014	RP-63	RP-140385	2161			Introduction of additional bandwidth combination set for CA_2A-4A	12.3.0
03-2014	RP-63	RP-140371	2131r 1			CR to finalize RI test for CoMP	12.3.0
03-2014	RP-63	RP-140368	2147			Correction of coding rate for 18RBs in UL RMC table	12.3.0
03-2014	RP-63	RP-140371	2144			Channel spacing for non-contiguous intra-band carrier aggregation	12.3.0
03-2014	RP-63	RP-140374	2163			Distributed EPDCCH Demodulation Test	12.3.0
03-2014	RP-63	RP-140368	2137			Configured transmitted power for CA	12.3.0
03-2014	RP-63	RP-140368	2122			CR for 36.101. Editorial correction on OCNB pattern	12.3.0
03-2014	RP-63	RP-140370	2160			Correction of table notes for NS_12-NS_15 spurious emissions requirements	12.3.0
03-2014	RP-63	RP-140371	2129r 1			CR to finalize fading CQI test for CoMP	12.3.0
03-2014	RP-63	RP-140375	2119			Introduction of requirements for SNR test for TM9	12.3.0
03-2014	RP-63	RP-140374	2125			CR on correction of downlink SDR tests with EPDCCH scheduling	12.3.0
03-2014	RP-63	RP-140371	2127			Correction on DL CoMP static CQI tests (Rel 12)	12.3.0
06-2014	RP-64	RP-140909	2177r 3			RF: Corrections to spurious emission requirements with NS different than NS_01 (Rel-12)	12.4.0
06-2014	RP-64	RP-140932	2187r 1			Additional bandwidth combination set for LTE Advanced inter-band Carrier Aggregation of Band 3 and Band 20	12.4.0
06-2014	RP-64	RP-140934	2188			Additional bandwidth combination set for LTE Advanced inter-band Carrier Aggregation of Band 7 and Band 20	12.4.0
06-2014	RP-64	RP-140943	2195r 1			CR for TS 36.101 on introduction CA_41D	12.4.0
06-2014	RP-64	RP-140943	2196r 3			CR to TS 36.101 on introduction of CA BW class D requirements	12.4.0
06-2014	RP-64	RP-140918	2198			CR on correction on TDD IRC CQI test	12.4.0
06-2014	RP-64	RP-140917	2207			CR of EPDCCH localized test with TM10 QCL Type-B configuration (Rel-12): correction of CSI-RS configurations	12.4.0
06-2014	RP-64	RP-140918	2209			Clean up of TM9 SNR tests	12.4.0
06-2014	RP-64	RP-140933	2210r 1			Introduction of band B4+B27 CA to TS36.101	12.4.0
06-2014	RP-64	RP-140942	2213			Introduction of CA band combination B1+B20 to TS 36.101	12.4.0
06-2014	RP-64	RP-140917	2216			CR for EPDCCH test (Rel-12)	12.4.0
06-2014	RP-64	RP-140914	2218			CR of modification on FeICIC rank testing (Rel-12)	12.4.0
06-2014	RP-64	RP-140914	2220			CR on FeICIC PBCH performance requirement (Rel-12)	12.4.0
06-2014	RP-64	RP-140918	2222			Correction on out-of-band blocking for CA	12.4.0
06-2014	RP-64	RP-140918	2226			Update demodulation performance requirements with new UE categories	12.4.0
06-2014	RP-64	RP-140911	2228			Correction for CA sustained data rate test (Rel-12)	12.4.0
06-2014	RP-64	RP-140945	2229			Correction on wrong annotation for close-loop spatial multiplexing performance	12.4.0
06-2014	RP-64	RP-140911	2233			Clarification of Intra-band contiguous CA class C Narrow band blocking requirements	12.4.0
06-2014	RP-64	RP-140911	2239			Correction for CA soft buffer test (Rel-12)	12.4.0
06-2014	RP-64	RP-140918	2241			CR on OCNB and propagation conditions for dual layer TM9 test (Rel-12)	12.4.0
06-2014	RP-64	RP-140911	2247			Remove [] from eICIC TDD RI requirement	12.4.0
06-2014	RP-64	RP-140914	2256			Verification of exceptions of REFSSENS requirements for carrier aggregation	12.4.0
06-2014	RP-64	RP-140914	2258			Applicability of exceptions to reference sensitivity requirements for CA	12.4.0
06-2014	RP-64	RP-140909	2269			In-band blocking case numbering re-establishment	12.4.0
06-2014	RP-64	RP-140918	2273			CR for TS36.101 FRC tables for COMP demodulation requirements	12.4.0
06-2014	RP-64	RP-140945	2277			Editorial correction of note in clause 4.4	12.4.0

06-2014	RP-64	RP-140926	2282r 1			Editorial correction of note in clause 4.4	12.4.0
06-2014	RP-64	RP-140911	2283			Introduction of new bandwidth combination set for CA_1A-5A UE	12.4.0
06-2014	RP-64	RP-140914	2286			CR for finalizing DL COMP CSI reporting requirements	12.4.0
06-2014	RP-64	RP-140914	2288			CR for adding DL CoMP CSI RMC tables (Rel-12)	12.4.0
06-2014	RP-64	RP-140921	2291			Simplification of 36.101 Table 5.6A.1-1 for LTE_CA_C_B27	12.4.0
06-2014	RP-64	RP-140914	2293			Finalization of CoMP demodulation test cases	12.4.0
06-2014	RP-64	RP-140918	2294			Editorial corrections for UE performance requirements for R12	12.4.0
06-2014	RP-64	RP-140937	2295			Introduction of CA performance requirements for Band 27 CA	12.4.0
06-2014	RP-64	RP-140931	2296			Introduction of CA 1+11 to 36.101 (Rel-12)	12.4.0
06-2014	RP-64	RP-140994	2309			Inclusion of the out of band emission limit concluded in CEPT into band 28	12.4.0
06-2014	RP-64	RP-140911	2314			UE to UE co-existence between B42/B43	12.4.0
06-2014	RP-64	RP-140911	2318			Perf: Corrections to CA (Class C) performance with power imbalance (Rel-12)	12.4.0
06-2014	RP-64	RP-140920	2319			Introduction of CA performance requirements for Band 23 CA	12.4.0
06-2014	RP-64	RP-140914	2321			CR of modification on FeICIC rank testing (Rel-12)	12.4.0
06-2014	RP-64	RP-140914	2323			CR of introducing FeICIC TM9 testing (Rel-12)	12.4.0
06-2014	RP-64	RP-140917	2325			CR for EPDCCH SDR test (Rel-12)	12.4.0
06-2014	RP-64	RP-140911	2328			Clean-up CR for demodulation requirements (Rel-12)	12.4.0
06-2014	RP-64	RP-140945	2330r 1			Additional updates of UE categories for demodulation performance requirements (Rel-12)	12.4.0
06-2014	RP-64	RP-140911	2333			Throughput calculation for eICIC demodulation requirements	12.4.0
06-2014	RP-64	RP-140914	2335r 1			Introduction of Band 28 requirements for flexible operation in Japan	12.4.0
06-2014	RP-64	RP-140911	2337r 1			Add missing Uplink downlink configuration to eICIC TDD RI requirement	12.4.0
06-2014	RP-64	RP-140945	2338			Add static propagation condition matrix for 1 x 2	12.4.0
06-2014	RP-64	RP-140911	2341			Cleanup of terminology for Rx requirements	12.4.0
06-2014	RP-64	RP-140945	2344			CR on separating CA UE demodulation tests from single carrier tests in Rel-12	12.4.0
06-2014	RP-64	RP-140911	2351			Test configuration for intra-band contiguous carrier aggregation power control	12.4.0
06-2014	RP-64	RP-140935	2358			Addition of bandwidth combination sets for CA_2A-29A, CA_3A-5A, CA_4A-5A, CA_4A-12A, and CA_4A-29A into 36.101	12.4.0
06-2014	RP-64	RP-140914	2362			Correction of test configurations for intra-band non-contiguous aggregation	12.4.0
06-2014	RP-64	RP-140911	2365			Clarification on CA bandwidth classes	12.4.0
06-2014	RP-64	RP-140917	2374			CR on correction of downlink SDR tests with EPDCCH scheduling	12.4.0
06-2014	RP-64	RP-140922	2377			Correction on LTE_CA_C_B39	12.4.0
06-2014	RP-64	RP-140911	2378			Corrections on CA CQI tests	12.4.0
06-2014	RP-64	RP-140930	2381r 1			Introduction of LTE-Advanced CA of Band 8 and Band 40 to TS36.101	12.4.0
06-2014	RP-64	RP-140927	2382r 1			FRC for DL MIMO enhancement PMI requirements	12.4.0
06-2014	RP-64	RP-140603	2384r 2			CR for TS 36.101 on introduction CA_40D	12.4.0
06-2014	RP-64	RP-140944	2385r 1			CR to TS 36.101 on introduction of 3DL intra-band non-contiguous CA requirements	12.4.0
06-2014	RP-64	RP-140938	2387			Introduction of CA_2A-2A into TS 36.101	12.4.0
06-2014	RP-64	RP-140927	2392			Introduction of 4Tx beam steering model	12.4.0
06-2014	RP-64	RP-140914	2394			CA_7C A-MPR Corrections	12.4.0
06-2014	RP-64	RP-140936	2395r 2			Introduction of a new CA_7C bandwidth combination set into 36.101	12.4.0
06-2014	RP-64	RP-140918	2398			CR for TS36.101 CSI RMC table	12.4.0
06-2014	RP-64	RP-140940	2413			Introduction of LTE_CA_NC_B42 into 36.101	12.4.0
06-2014	RP-64	RP-140942	2420			Introduction of CA band combination B1+B20 to TS 36.101	12.4.0
06-2014	RP-64	RP-140919	2422			CA_3C is deleting 75RB+75RB uplink configuration for reference sensitivity	12.4.0
06-2014	RP-64	RP-140914	2425			CR on correction for TM10 CSI reporting requirements	12.4.0
09-2014	RP-65	RP-141197	2458r 1			Introduction of CA_B1_B3_B19 into TS 36.101	12.5.0
09-2014	RP-65	RP-141428	2568			Updated REFSENS requirements for band combinations with Band 4 and Band 12	12.5.0
09-2014	RP-65	RP-141468	2508r 1			Introduction of 3 DL CA for Band 1+3+20	12.5.0
09-2014	RP-65	RP-141469	2571			Correction to CA in Band 1+20	12.5.0
09-2014	RP-65	RP-141525	2504r 1			Perf: Cleanup and better description of DL-RMC-s with dynamic coding rate for CSI requirements (Rel-12)	12.5.0
09-2014	RP-65	RP-141525	2565			Corrections to UE coex table	12.5.0
09-2014	RP-65	RP-141527	2434			Correction on support of a bandwidth combination set	12.5.0
09-2014	RP-65	RP-141527	2452r 1			Remove the redundant table for FDD 4Tx multi-layer tests and correct the test case number (Rel-12)	12.5.0

09-2014	RP-65	RP-141527	2466		Unequal DL CC RB allocations in Maximum input level	12.5.0
09-2014	RP-65	RP-141527	2469		Intra-band contiguous CA ACS case 2 test clarification	12.5.0
09-2014	RP-65	RP-141527	2484		Corrections on delta Tc for UE MOP for intra-band contiguous CA	12.5.0
09-2014	RP-65	RP-141527	2487		Removal of Class B in UE TX requirement	12.5.0
09-2014	RP-65	RP-141527	2516r 1		CR for CA applicability rule in 36.101 in Rel-12	12.5.0
09-2014	RP-65	RP-141527	2519r 1		Editorial CR for CA performance tests in 36.101 in Rel-12	12.5.0
09-2014	RP-65	RP-141527	2548		Correction to NS_20 A-MPR for Band 23	12.5.0
09-2014	RP-65	RP-141530	2447		CR of introducing FelCIC TM9 testing (Rel-12)	12.5.0
09-2014	RP-65	RP-141530	2454		Maintenance of CoMP demodulation performance requirements (Rel-12)	12.5.0
09-2014	RP-65	RP-141530	2456		Clean-up CR for EPDCCH and FelCIC PBCH (Rel-12)	12.5.0
09-2014	RP-65	RP-141530	2471		Throughput calculation for felCIC demodulation requirements	12.5.0
09-2014	RP-65	RP-141532	2439		CR on correction on CQI reporting TDD CSI meas in case two CSI subframe sets with CRS test (Rel-12)	12.5.0
09-2014	RP-65	RP-141532	2441		CR on correction on RI reporting CSI meas in case two CSI subframe sets with CRS tests (Rel-12)	12.5.0
09-2014	RP-65	RP-141532	2444		Clarification of high speed train scenario in 36.101 (Rel-12)	12.5.0
09-2014	RP-65	RP-141532	2478		CQI reporting under fading: CQI indices in set	12.5.0
09-2014	RP-65	RP-141532	2490		Correction on A-MPR table	12.5.0
09-2014	RP-65	RP-141532	2499		RF: Corrections to spurious emission band co-existence requirement for Band 44	12.5.0
09-2014	RP-65	RP-141535	2559		Addition of E-UTRA CA configurations and bandwidth combination sets defined for inter-band CA for Band 4 and 27	12.5.0
09-2014	RP-65	RP-141537	2541		Band 42 contiguous CA channel bandwidth correction	12.5.0
09-2014	RP-65	RP-141546	2463r 1		Introduction of PMI reporting requirements for DL MIMO enhancement	12.5.0
09-2014	RP-65	RP-141548	2457r 2		Introduction of CA_B1_B3 into TS 36.101	12.5.0
09-2014	RP-65	RP-141549	2556		Addition of bandwidth combination set for CA_2A-4A	12.5.0
09-2014	RP-65	RP-141550	2566		Addition of 3MHz bandwidth for Band 12 , in the B2+B12 CA combination	12.5.0
09-2014	RP-65	RP-141551	2445		Introduction of CA 8+11 to 36.101 (Rel-12)	12.5.0
09-2014	RP-65	RP-141553	2491r 1		Introduction of a new bandwidth combination set for CA_25A-25A into 36.101	12.5.0
09-2014	RP-65	RP-141554	2533r 1		Introduction of requirements for 3DL inter-band carrier aggregation (FDD)	12.5.0
09-2014	RP-65	RP-141554	2534		Introduction of requirements for 3DL combinations with Band 30 (FDD)	12.5.0
09-2014	RP-65	RP-141557	2461r 1		Introduction of CA_B19_B42_B42 into TS 36.101	12.5.0
09-2014	RP-65	RP-141559	2460r 1		Introduction of CA_B1_B42_B42 into TS 36.101	12.5.0
09-2014	RP-65	RP-141560	2427		Adding 15MHz channel BW to B40 3DL and new bandwidth combination set for the 2DL	12.5.0
09-2014	RP-65	RP-141561	2488r 1		Corrections on Maximum input level for intra-band non-contiguous 3DL	12.5.0
09-2014	RP-65	RP-141562	2436		Corrections on Maximum input level and ACS for intra-band CA	12.5.0
09-2014	RP-65	RP-141562	2481r 1		Introduction of CA band combination B41+ B42 to TS 36.101	12.5.0
09-2014	RP-65	RP-141562	2522		CR on CA power imbalance tests in Rel-12	12.5.0
09-2014	RP-65	RP-141562	2560		CR Reducing MPR for Contiguous CA with Non-Contiguous Resource Allocations	12.5.0
09-2014	RP-65	RP-141563	2555r 1		UL configuration for CA_4A-12A reference sensitivity	12.5.0
09-2014	RP-65	RP-141563	2557		Addition of bandwidth combination set for CA_4A-12A	12.5.0
09-2014	RP-65	RP-141612	2494r 2		Introduction of inter-band CA_18-28 into TS36.101	12.5.0
09-2014	RP-65	RP-141635	2552r 2		Introduction of CA_1A-7A into 36.101(Rel-12)	12.5.0
09-2014	RP-65	RP-141636	2480r 2		Introduction of 3DLs CA band combination of Band1 +5 + 7 to TS 36.101 Rel-12	12.5.0
09-2014	RP-65	RP-141653	2435r 3		Introduction of 3 Band Carrier Aggregation (3DL/1UL) of Band 1, Band 3 and Band 8 to TS 36.101	12.5.0
09-2014	RP-65	RP-141682	2570r 1		Introduction of CA band combination B1+B7+B20 to TS 36.101	12.5.0
09-2014	RP-65	RP-141708	2492r 3		Introduction of 3 Band Carrier Aggregation of Band 1,Band 3 and Band 5 to TS 36.101	12.5.0
12-2014	RP-66	RP-142147	2671		Correction of CoMP TDD CSI tests (Rel-12)	12.6.0
12-2014	RP-66	RP-142144	2574		CR for REFSENSE in lower SNR and change history	12.6.0
12-2014	RP-66	RP-142173	2581		CR on 4Tx codebook PMI testing	12.6.0
12-2014	RP-66	RP-142142	2587		CR for 1 PRB allocation performance in presence of MBSFN (rel-12)	12.6.0
12-2014	RP-66	RP-142144	2590		Maintenance of CA demodulation performance requirements (Rel-	12.6.0

					12)	
12-2014	RP-66	RP-142147	2592		Clean up for FeICIC demodulation performance requirements (Rel-12)	12.6.0
12-2014	RP-66	RP-142166	2600		Correction of placement of CA_40D in Table	12.6.0
12-2014	RP-66	RP-142162	2601		CQI test for TDD CL_C 20MHz+15MHz in Rel-12	12.6.0
12-2014	RP-66	RP-142162	2602		Sustained downlink data rate test for TDD CL_C 20MHz+15MHz in Rel-12	12.6.0
12-2014	RP-66	RP-142165	2611		Removal of square brackets for CA_B1_B3 and CA_B1_B3_B19	12.6.0
12-2014	RP-66	RP-142147	2620		CQI reporting in AWGN: CQI indices in set	12.6.0
12-2014	RP-66	RP-142147	2629		CR to fix error of CA capability for CA performance tests in 36.101 in Rel-12	12.6.0
12-2014	RP-66	RP-142144	2637		Definition of the bits in the bitmap for indication of modified MPR behavior	12.6.0
12-2014	RP-66	RP-142147	2641		Applicability of in-gap and out-of-gap measurements for intra-band NC CA	12.6.0
12-2014	RP-66	RP-142183	2642		Introduction of additional bandwidth combination set for CA_2A-5A	12.6.0
12-2014	RP-66	RP-142164	2643		Corrections for 3DL inter-band CA band combinations	12.6.0
12-2014	RP-66	RP-142147	2661		Maintenance of TM10 demodulation test configurations on PQI set and ZP-CSIRS (Rel-12 test 8.3.1.3.2, 8.3.2.4.2)	12.6.0
12-2014	RP-66	RP-142173	2582r1		Introduction of PUSCH 3-2 requirements into TS36.101	12.6.0
12-2014	RP-66	RP-142162	2603r1		Normal demodulation test for TDD CL_C 20MHz+15MHz in Rel-12	12.6.0
12-2014	RP-66	RP-142164	2576r1		Corrections on Out-of-band blocking requirements for CA Class B and D	12.6.0
12-2014	RP-66	RP-142149	2678		CR to specify applicability of CoMP RI test (Rel-12)	12.6.0
12-2014	RP-66	RP-142144	2688		Removal of bracket for UL MIMO	12.6.0
12-2014	RP-66	RP-142164	2689		Corection of B29 REFSSENS for CA_2A-29A-30A and CA_4A-29A-30A	12.6.0
12-2014	RP-66	RP-142144	2700		Delete the incorrect notes for FDD DMRS demodulation tests (Rel-12)	12.6.0
12-2014	RP-66	RP-142160	2594r3		Correcting requirements for inter-band CA_18-28 in TS36.101	12.6.0
12-2014	RP-66	RP-142173	2705		CR of modification on PMI reporting requirements for DL MIMO enhancement	12.6.0
12-2014	RP-66	RP-142144	2720		Band 22 correction in UE to UE co-existence table.	12.6.0
12-2014	RP-66	RP-142147	2722		Correction to non-contiguous downlink intraband CA receiver requirements	12.6.0
12-2014	RP-66	RP-142159	2752		Removal of dRib from CA_1A-7A	12.6.0
12-2014	RP-66	RP-142147	2723		Correction to table format of allowed channel bandwidths of non-contiguous intraband CA	12.6.0
12-2014	RP-66	RP-142164	2643r1		Corrections for 3DL inter-band CA band combinations	12.6.0
12-2014	RP-66	RP-142146	2731		Modifications for NS_12 and NS_13	12.6.0
12-2014	RP-66	RP-142189	2739		Introduction of CA_5-13 into 36.101	12.6.0
12-2014	RP-66	RP-142173	2706r1		CR of reference measurement channel for PUSCH3-2 test	12.6.0
12-2014	RP-66	RP-142144	2727r1		CR for CA applicability rule in 36.101 in Rel-12	12.6.0
12-2014	RP-66	RP-142188	2676r1		CR to remove CA capability column in CA performance test tables (Rel-12)	12.6.0
12-2014	RP-66	RP-142173	r3		Introduction of PUSCH 3-2 requirements into TS36.101	12.6.0
12-2014	RP-66	RP-142187	2690r1		CR on sustained data rate test for 3DL CA	12.6.0
12-2014	RP-66	RP-142187	2681r2		CR on normal demodulation test for 3DL CA	12.6.0
12-2014	RP-66	RP-142147	2747r1		TS36.101 removal of brackets (RF)	12.6.0
12-2014	RP-66	RP-142144	2755		Correction to Transmit Modulation Quality for CA	12.6.0
12-2014	RP-66	RP-142144	2710r1		Clarification on UL and DL CA	12.6.0
12-2014	RP-66	RP-142144	2717r1		Clarification of notes relating to interferer offsets in intraband CA receiver requirement tables.	12.6.0
12-2014	RP-66	RP-142147	2735r1		Band 28 and NS_24	12.6.0
12-2014	RP-66	RP-142179	2684r1		CR for UE requirements for 256QAM	12.6.0
12-2014	RP-66	RP-142180	2729r1		Introduction of Dual Connectivity to TS 36.101 Rel-12, RF part	12.6.0
12-2014	RP-66	RP-142184	2680r1		Introduction of dual uplink inter-band CA in TS 36.101 rel-12	12.6.0
12-2014	RP-66	RP-142182	2701r1		Introduction of inter-band CA_1-28 into TS36.101	12.6.0
12-2014	RP-66	RP-142144	2758		Correction to Note 2 of Harmonic Signal Exceptions in Spurious	12.6.0

					Emissions	
12-2014	RP-66	RP-142144	2751r 2		Removal of brackets and TBD from CA feature	12.6.0
12-2014	RP-66	RP-142144	2697r 1		Maintenance of CA performance requirements (Rel-12)	12.6.0
12-2014	RP-66	RP-142187	2679r 2		CR to introduce CQI test for 3 DL CA	12.6.0
12-2014	RP-66	RP-142185	2721r 1		Addition of 2UL non-contiguous intraband CA feature	12.6.0
12-2014	RP-66	RP-142144	2704r 2		UE to UE co-existence between B42/B43	12.6.0
12-2014	RP-66	RP-142176	2685r 2		Introduction of LC MTC into TS 36.101	12.6.0
12-2014	RP-66	RP-142190	2759r 1		Introduction of additional band combinations for 3DL inter-band CA	12.6.0
03-2015	RP-67	RP-150387	2760r 2		Introduce additional bands of LC MTC	12.7.0
03-2015	RP-67	RP-150387	2761		CR on corrections to Dual-Layer Spatial Multiplexing with multiple CSI-RS config Rel-12	12.7.0
03-2015	RP-67	RP-150392	2765r 1		CR for applicability and test rules for TDD-FDD CA performance requirements	12.7.0
03-2015	RP-67	RP-150392	2766		Introduction of CQI tests for TDD-FDD CA	12.7.0
03-2015	RP-67	RP-150395	2767r 1		CR to introduce the SU-MIMO whitening verification test	12.7.0
03-2015	RP-67	RP-150392	2768r 1		CR on power imbalance test for 3DL CA	12.7.0
03-2015	RP-67	RP-150392	2769		CR on sustained data rate test for TDD FDD CA	12.7.0
03-2015	RP-67	RP-150394	2770r 1		CR for introduction of 256QAM demodulation performance requirements	12.7.0
03-2015	RP-67	RP-150393	2772r 1		CR: DC UE performance requirements	12.7.0
03-2015	RP-67	RP-150390	2773r 1		CR: MTC demodulation performance requirements	12.7.0
03-2015	RP-67	RP-150390	2774r 1		CR: MTC CSI requirements	12.7.0
03-2015	RP-67	RP-150396	2775r 1		Introduction of the eIMTA functional PDSCH demodulation test	12.7.0
03-2015	RP-67	RP-150387	2776r 3		CR on RF core requirements for D2D	12.7.0
03-2015	RP-67	RP-150387	2777		Modification of CSI reference measurement channel Rel-12	12.7.0
03-2015	RP-67	RP-150388	2779		Editorial correction for CA_18A-28A	12.7.0
03-2015	RP-67	RP-150388	2781		Removing brackets for CA_1A-28A MSD requirements	12.7.0
03-2015	RP-67	RP-150384	2783		Editorial correction on symbols for enhanced performance requirements type A	12.7.0
03-2015	RP-67	RP-150387	2784		Corrections on reference measurement channel	12.7.0
03-2015	RP-67	RP-150388	2792		Correction of TS 36.101 for the Pcell support of 25+41	12.7.0
03-2015	RP-67	RP-150395	2793r 1		CR for single cell demodulation test for SU-MIMO	12.7.0
03-2015	RP-67	RP-150391	2794		Introduction of CA_3A-42A and CA_3A-42C into 36.101	12.7.0
03-2015	RP-67	RP-150384	2797		UL HARQ in PDSCH and PDCCH/PCFICH demod test cases for eICIC/feICIC with MBSFN ABS	12.7.0
03-2015	RP-67	RP-150382	2800		Correction to eICIC aggressor cell configurations	12.7.0
03-2015	RP-67	RP-150387	2801		R4-73AH-0040: Correction for uplik CA configuration in TS 36.101 Rel-12	12.7.0
03-2015	RP-67	RP-150387	2802r 1		Correction of MSD levels for CA_1A-8A in TS 36.101 rel-12	12.7.0
03-2015	RP-67	RP-150387	2805		Removal of eDL-MIMO term from specification	12.7.0
03-2015	RP-67	RP-150388	2809		Clarification of 2UL/3DL contiguous intraband CA REFSENS test	12.7.0
03-2015	RP-67	RP-150392	2811r 1		CR on TM4 normal demodulation test for 3DL CA	12.7.0
03-2015	RP-67	RP-150392	2812		CR on introducing new DL referece measurement channels	12.7.0
03-2015	RP-67	RP-150392	2813r 1		CR on normal demodulation test for TDD-FDD CA	12.7.0
03-2015	RP-67	RP-150388	2815		Additions of bandwidth combination set reference	12.7.0
03-2015	RP-67	RP-150388	2816		Correction of band number in Table 5.6A.1-2a for LTE_CA_B4_B12_B30	12.7.0
03-2015	RP-67	RP-150382	2819		UE to UE co-existence between B42/B43	12.7.0
03-2015	RP-67	RP-150382	2822		Corrections to CA in-band emissions requirement	12.7.0
03-2015	RP-67	RP-150381	2830		Uplink RMCs for sustained data rate test	12.7.0
03-2015	RP-67	RP-150382	2833		Corrections to the CA power imbalance test	12.7.0
03-2015	RP-67	RP-150392	2839r 1		CR for soft buffer tests for TDD-FDD CA in 36.101 in Rel-12	12.7.0
03-2015	RP-67	RP-150392	2842		Editorial CR for CA UE performance tests in 36.101 in Rel-12	12.7.0
03-2015	RP-67	RP-150387	2847		UE spurious emissions structure correction for CA	12.7.0
03-2015	RP-67	RP-150387	2850		Correction of PCMAX for uplink inter-band and intra-band carrier	12.7.0

					aggregation	
03-2015	RP-67	RP-150387	2851		Exceptions for spurious response for UL CA	12.7.0
03-2015	RP-67	RP-150388	2852r 1		Correction of REFSENS, OOB and uplink configuration for 3DL/1UL CA	12.7.0
03-2015	RP-67	RP-150390	2853		SNR definition for category 0 UE	12.7.0
03-2015	RP-67	RP-150390	2854r 1		FRC for category 0 UE PDSCH performance requirements	12.7.0
03-2015	RP-67	RP-150390	2855r 1		Introduction of new PHICH and PBCH performance requirements for category 0 UE	12.7.0
03-2015	RP-67	RP-150387	2861		Correction to FOOB reference in definition of MPR for contiguous CA with non-contiguous resource allocation	12.7.0
03-2015	RP-67	RP-150387	2862		Band 31 update	12.7.0
03-2015	RP-67	RP-150384	2867		Implementation of CA configurations specified in later releases	12.7.0
06-2015	RP-68	RP-150958	2870r 2		Intra-band contiguous CA reference sensitivity definition for Class D	12.8.0
06-2015	RP-68	RP-150961	2881r 2		CR on MTC CQI tests	12.8.0
06-2015	RP-68	RP-150962	2882r 2		CR on 256QAM demodulation performance requirements	12.8.0
06-2015	RP-68	RP-150962	2883r 3		CR on 256QAM sustained data rate tests for single carrier and TDD or FDD CA	12.8.0
06-2015	RP-68	RP-150962	2885r 4		CR on 256QAM CQI test	12.8.0
06-2015	RP-68	RP-150963	2886r 3		CR on DC SDR tests	12.8.0
06-2015	RP-68	RP-150963	2887r 2		Maintenance CR for DC demodulation performance requirements	12.8.0
06-2015	RP-68	RP-150958	2888		CR to restore R.10-2 FDD	12.8.0
06-2015	RP-68	RP-150961	2889r 3		Introduction of UE category 0 PDSCH/PHICH/PBCH performance requirements	12.8.0
06-2015	RP-68	RP-150954	2901		UE to UE co-existence between B42/B43	12.8.0
06-2015	RP-68	RP-150958	2902		Correction of maximum aggregated bandwidth for CA_26A-41A	12.8.0
06-2015	RP-68	RP-150957	2903r 2		Introduction of TDD SU-MIMO whitening verification test	12.8.0
06-2015	RP-68	RP-150958	2904		Correction of FRC table for CA demodulation with power imbalance	12.8.0
06-2015	RP-68	RP-150958	2905r 1		Add SCell power levels for 2DL CA power imbalance test	12.8.0
06-2015	RP-68	RP-150955	2907		Corrections on UL transmit power for CA receiver requirements	12.8.0
06-2015	RP-68	RP-150958	2909		Corrections to the CA power imbalance test	12.8.0
06-2015	RP-68	RP-150957	2910r 1		Clarification on RMC for D2D UE	12.8.0
06-2015	RP-68	RP-150960	2911		Correction on TDD eMTC PDSCH functionality test	12.8.0
06-2015	RP-68	RP-150954	2931		3.5 GHz out-of-band blocking	12.8.0
06-2015	RP-68	RP-150965	2933		Correction of FRC names	12.8.0
06-2015	RP-68	RP-150954	2936		Correction of the 3DL CA REFSENS	12.8.0
06-2015	RP-68	RP-150962	2939r 1		CR on 256QAM sustained data rate tests for TDD FDD CA	12.8.0
06-2015	RP-68	RP-150958	2940r 1		Maintenance CR for 3DL CA performance requirements	12.8.0
06-2015	RP-68	RP-150958	2941r 1		Maintenance CR for TDD FDD CA demodulation performance requirements	12.8.0
06-2015	RP-68	RP-150965	2944		Corrections on 2UL intra-band non-contiguous CA requirements	12.8.0
06-2015	RP-68	RP-150958	2947		Updates to the definitions of CA capability (Rel-12)	12.8.0
06-2015	RP-68	RP-150955	2950		Clarification of PDSCH allocation in CSI PUSCH 3-0 feIC tests (Rel-12)	12.8.0
06-2015	RP-68	RP-150954	2956		NS value for intra-band contiguous CA configurations not allowed A-MPR	12.8.0
06-2015	RP-68	RP-150957	2958		Receiver spurious emissions requirements for downlink-only bands	12.8.0
06-2015	RP-68	RP-150958	2959		Amendments to MPR for uplink inter-band and intra-band non-contiguous CA	12.8.0
06-2015	RP-68	RP-150958	2960r 1		NS values for secondary cells of non-contiguous CA configurations	12.8.0
06-2015	RP-68	RP-150955	2961r 1		Corrections to test configurations for intra-band non-contiguous CA	12.8.0
06-2015	RP-68	RP-150954	2962		Corrections to test configurations for 3DL inter-band CA	12.8.0
06-2015	RP-68	RP-150958	2967		Adding REFSENS exception requirements for 1+3+26	12.8.0
06-2015	RP-68	RP-150954	2971		Corrections to NS_22 and NS_23	12.8.0
06-2015	RP-68	RP-150958	2972		Corrections to 41D fallback	12.8.0
06-2015	RP-68	RP-150957	2972		Corrections to EVM requirements for ProSe and Annex F of 36.101	12.8.0
06-2015	RP-68	RP-150958	2976		Removal of B27 from 2UL CA_7A_20A co-existence protected band list	12.8.0
06-2015	RP-68	RP-150957	2977r		CR on corrections to D2D RF core requirements	12.8.0

			1				
06-2015	RP-68	RP-150963	2978r 1			CR on corrections to D2D RF core requirements	12.8.0
06-2015	RP-68	RP-150957	2979			CR clarification of RMC for DL category 0 UE HD-FDD	12.8.0
06-2015	RP-68	RP-150960	2980r 1			Introduction of TDD eMTC CQI requirement	12.8.0
06-2015	RP-68	RP-150958	2985			Change of 1.4MHz single carrier SNR values for multiple CA configurations	12.8.0
06-2015	RP-68	RP-150954	2992			Clarification to spurious emission requirement for the edge of spurious domain	12.8.0
06-2015	RP-68	RP-150955	2996			Correction to CA_7C A-MPR in CA-NS_06	12.8.0
06-2015	RP-68	RP-150965	2998r 1			CR to update UE performance tests for UE DL category in 36.101 in Rel-12	12.8.0
06-2015	RP-68	RP-150965	2999			CR to update Annex for new DL category in 36.101 in Rel-12	12.8.0
06-2015	RP-68	RP-150958	3002			CR for updating CA applicability rule in 36.101 in Rel-12	12.8.0
06-2015	RP-68	RP-150957	3005r 1			CR for Rel-12 NAICS - Definitions	12.8.0
06-2015	RP-68	RP-150965	3012r 1			Clarification on uplink configuration for reference sensitivity of inter-band CA	12.8.0
06-2015	RP-68	RP-150954	3018			EVM for Intra-band contiguous UL CA for non-equal Channel BWs	12.8.0
06-2015	RP-68	RP-150958	3019			A-MPR correction for CA_39C CA_NS_07	12.8.0
09-2015	RP-69	RP-151482	3006r 3			CR for Rel-12 NAICS - Demodulation Test	12.9.0
09-2015	RP-69	RP-151482	3008r 3			CR for Rel-12 NAICS - Interference Models	12.9.0
09-2015	RP-69	RP-151482	3009r 3			CR for Rel-12 NAICS - CQI Tests	12.9.0
09-2015	RP-69	RP-151483	3024			Corrections to CSI PUCCH 1-0 static test 4 and PUSCH 3-2 tests	12.9.0
09-2015	RP-69	RP-151476	3025			Correction to RC.2 TDD Nr. HARQ Proc. into TS36.101	12.9.0
09-2015	RP-69	RP-151479	3027			Table 7.3.1A-0f (2UL CA MSD) notes numbering correction	12.9.0
09-2015	RP-69	RP-151479	3030r 1			Correction to TDD FDD CA	12.9.0
09-2015	RP-69	RP-151483	3032			Alignment of CA Receiver requirements parameters	12.9.0
09-2015	RP-69	RP-151476	3035			Correction to CoMP demodulation requirements	12.9.0
09-2015	RP-69	RP-151475	3039			Correction to RI test parameters in TS 36.101 (Rel-12)	12.9.0
09-2015	RP-69	RP-151483	3049			UE co-existence requirements between Band 42 and Japanese bands	12.9.0
09-2015	RP-69	RP-151483	3051			Introduction of relaxation rule for multiple 3DL inter-band CA configurations	12.9.0
09-2015	RP-69	RP-151483	3053			Removal of square brackets of B42 requirements in Rel-12 specification	12.9.0
09-2015	RP-69	RP-151479	3059r 1			Corrections on CA reference sensitivity requirements	12.9.0
09-2015	RP-69	RP-151480	3061r 1			Correction for eMTC CQI tests	12.9.0
09-2015	RP-69	RP-151483	3062			Maintenance of eMTC PDSCH demodulation test	12.9.0
09-2015	RP-69	RP-151479	3067r 1			Corrections of Spurious emission band UE co-existence for interband 2UL CA in Table 6.6.3.2A-0	12.9.0
09-2015	RP-69	RP-151483	3069r 1			Revisions of Spurious emission band UE co-existence in Table 6.6.3.2-1	12.9.0
09-2015	RP-69	RP-151475	3075			Correction to PDCCH/PCFICH test parameters in TS 36.101 (Rel-12)	12.9.0
09-2015	RP-69	RP-151475	3079			Correction to PMI delay in PMI test for TDD	12.9.0
09-2015	RP-69	RP-151479	3082			Maintenance CR for MTC CSI performance requirements	12.9.0
09-2015	RP-69	RP-151479	3084			Maintenance CR for SCE demodulation and CSI requirements	12.9.0
09-2015	RP-69	RP-151479	3086			Maintenance CR for DC demodulation performance requirements and SDR tests	12.9.0
09-2015	RP-69	RP-151479	3088r 1			Cleanup of TDD-FDD CA demodulation performance requirements	12.9.0
09-2015	RP-69	RP-151479	3090			Cleanup of R12 SU-MIMO Enhanced Performance Type C requirements	12.9.0
09-2015	RP-69	RP-151482	3093r 1			CR for Rel-12 NAICS - Fixed Reference Channels	12.9.0
09-2015	RP-69	RP-151481	3096r 2			CR on demodulation performance requirements for D2D Discovery	12.9.0
09-2015	RP-69	RP-151481	3097r 2			CR on demodulation performance requirements for D2D Communication	12.9.0
09-2015	RP-69	RP-151475	3101			Correction on UE maximum output power class of Band 22 for UL MIMO	12.9.0
09-2015	RP-69	RP-151479	3103			Removal of square brackets for Cat-0 UE demodulation requirements	12.9.0
09-2015	RP-69	RP-151479	3105			Removal of square brackets for LTE-CA_B41_B42	12.9.0
09-2015	RP-69	RP-151479	3111r 1			Corrections on 3DL CA performance requirements	12.9.0

09-2015	RP-69	RP-151483	3119		Minor correction in 36.101	12.9.0
09-2015	RP-69	RP-151483	3120		CR adding clarification for Band 28 restrictions in 36.101	12.9.0
09-2015	RP-69	RP-151483	3126		CR for UE performance tests for intra-band contiguous CA with minimum channel spacing on Band 41	12.9.0
09-2015	RP-69	RP-151483	3134r 1		Modification of test parameters for TM9 demodulation with 256QAM (Rel-12)	12.9.0
09-2015	RP-69	RP-151479	3136r 1		Spreading of harmonic for 2UL interband and 2 UL non-contiguous intraband CA	12.9.0
09-2015	RP-69	RP-151479	3140		Correction to FDD-TDD closed loop spatial multiplexing 3CC requirement table	12.9.0
09-2015	RP-69	RP-151479	3142r 1		Correction to DC supported testable bandwidth list	12.9.0
09-2015	RP-69	RP-151479	3144r 1		Clarification of UL configuration for CA demodulation requirements	12.9.0
09-2015	RP-69	RP-151479	3152		Corrections to CSI RMCs used for PUSCH 3-2 testing (Rel-12)	12.9.0
09-2015	RP-69	RP-151483	3154r 1		Corrections to applicability of CSI requirements for low UE categories (Rel-12)	12.9.0
09-2015	RP-69	RP-151349	3156r 4		CR for Rel-12 NAICS - TM10 Demodulation and CSI Test	12.9.0
09-2015	RP-69	RP-151475	3161		Correction of applicability of CA_NS_31	12.9.0
12-2015	RP-70	RP-152131	3176r 1		Release 12 CR to align NS_04 values to meet FCC OOB requirements	12.10.0
12-2015	RP-70	RP-152136	3179r 1		Editorial correction for eIMTA CQI tests	12.10.0
12-2015	RP-70	RP-152135	3182r 1		CR to finalize demodulation performance requirements for D2D Communication	12.10.0
12-2015	RP-70	RP-152133	3185r 1		Simplified CA fading Test method becomes optional	12.10.0
12-2015	RP-70	RP-152135	3187r 1		CR on corrections for ProSe Direct Discovery demodulation requirements	12.10.0
12-2015	RP-70	RP-152133	3190		Correction of the applicable UE categories for 256QAM UE demodulation performance requirements (Rel-12)	12.10.0
12-2015	RP-70	RP-152133	3192r 1		Correction of TDD-FDD CA performance requirements (Rel-12)	12.10.0
12-2015	RP-70	RP-152133	3194		Correction on FDD CA and TDD TDD CA performance requirements (Rel-12)	12.10.0
12-2015	RP-70	RP-152130	3201r 1		CR: Removal of 1.4MHz MBMS test (Rel-12)	12.10.0
12-2015	RP-70	RP-152132	3204		Correction of the AMPR table for NS_14 in TS 36.101 R12	12.10.0
12-2015	RP-70	RP-152133	3213		Corrections to the CSI minimum requirement for PUSCH 3-2 (Rel-12)	12.10.0
12-2015	RP-70	RP-152133	3215r 1		Corrections to MIMO Correlation Matrices using cross polarized antennas (Rel-12)	12.10.0
12-2015	RP-70	RP-152136	3224r 1		CR for UE performance tests for intra-band contiguous CA with minimum channel spacing on Band 41	12.10.0
12-2015	RP-70	RP-152136	3226r 1		Correction in SNR definition for CSI test	12.10.0
12-2015	RP-70	RP-152130	3231		Correction to reference channel for CQI requirements	12.10.0
12-2015	RP-70	RP-152164	3243		Introduction of 2 UL and 3 DL interband cases with MSD	12.10.0
12-2015	RP-70	RP-152132	3245		CR on FRC for CDM-multiplexed DM RS	12.10.0
12-2015	RP-70	RP-152132	3248		Correction to physical channel for CQI reporting in type A test case	12.10.0
12-2015	RP-70	RP-152133	3260		CR for Rel-12 NAICS - Demodulation Test	12.10.0
12-2015	RP-70	RP-152133	3262		Correction on CA_4A-4A-5A table reference	12.10.0
12-2015	RP-70	RP-152136	3268		Clarification of Pcell support in 36.101 in CA scenarios	12.10.0
12-2015	RP-70	RP-152132	3272		A-MPR correction for CA_NS_06 CA-7C non-contiguous RB allocation	12.10.0
12-2015	RP-70	RP-152136	3275r 1		Clarification on relative power tolerance for CA	12.10.0
12-2015	RP-70	RP-152133	3279		Correction of uplink configuration for CA_18-28	12.10.0
12-2015	RP-70	RP-152131	3284		Missing RB allocation and OCNG Pattern for Cat 1 UEs in Multiple PMI CSI Reference Symbol tests	12.10.0
12-2015	RP-70	RP-152131	3293r 1		Correction of supported sub-block frequency arrangement for CA_41-41	12.10.0
12-2015	RP-70	RP-152131	3295		Correction of test configuration for combinations of inter-band and intra-band CA	12.10.0
12-2015	RP-70	RP-152136	3310		Correction on CQI test 1A for TDD eIMTA	12.10.0
12-2015	RP-70	RP-152133	3313		Correction of the resource allocation in FRC for CAT0 UE demodulation tests	12.10.0
12-2015	RP-70	RP-152133	3328r 1		Removal of DC channel bandwidth combination set table	12.10.0
12-2015	RP-70	RP-152136	3330		CR on demodulation requirements of Dual Connectivity	12.10.0
12-2015	RP-70	RP-152133	3333		Correction of MSD levels for 2UL inter-band CA in TS 36.101 Rel-12	12.10.0
12-2015	RP-70	RP-152164	3344		Removal of (NOTE 4) from Table 5.6A.1-2a	12.10.0

12-2015	RP-70	RP-152136	3351			CR: PDSCH ETU600 performance requirements	12.10.0
12-2015	RP-70	RP-152133	3374r 1			Correction to P _{cm} for CA to include delta_T_ProSe	12.10.0
12-2015	RP-70	RP-152136	3377			NS_05 modification for PHS protection in Japan	12.10.0
01-2016	RP-70					Editorial correction to sections 6.6.3.3.18 (put back to void) and renamed to section 6.6.3.3.19	12.10.1
03-2016	RP-71	RP-160488	3380			Correction to Type A CQI test parameters in TS 36.101	12.11.0
03-2016	RP-71	RP-160489	3383			Correction in beam steering rate for 4 Tx antenna in Rel-12	12.11.0
03-2016	RP-71	RP-160489	3385			CR for correction to syncOffsetIndicator parameter in D2D resource pool configuration	12.11.0
03-2016	RP-71	RP-160489	3389			Correction for eMTC CQI reporting tests	12.11.0
03-2016	RP-71	RP-160488	3392			Beamforming model correction on TM10 DPS UE tests	12.11.0
03-2016	RP-71	RP-160489	3398			[Rel-12] NS_05 modification for PHS protection in Japan	12.11.0
03-2016	RP-71	RP-160488	3404			CQI reports in CoMP fading test	12.11.0
03-2016	RP-71	RP-160489	3410r 1			Correction of P _{cm} for Dual Connectivity	12.11.0
03-2016	RP-71	RP-160489	3418r 1			Alignment of Inter-band CA with two bands	12.11.0
03-2016	RP-71	RP-160489	3426			Corrections to Notes in 2UL spurious emission table	12.11.0
03-2016	RP-71	RP-160487	3428			Rel-12] Correction on Intra-band non-contiguous CA	12.11.0
03-2016	RP-71	RP-160489	3435			Correction on UE category in Annex of TS 36.101	12.11.0
03-2016	RP-71	RP-160489	3437			Removal of brackets for Maximum input level for 256QAM in TS 36.101	12.11.0
03-2016	RP-71	RP-160489	3439			Removal of brackets for Measurement channels for MTC in TS 36.101	12.11.0
03-2016	RP-71	RP-160489	3448			Removing DC_5-17 from 36.101 Rel 12	12.11.0
03-2016	RP-71	RP-160488	3451			Correction to TDD CQI Reporting for feICIC	12.11.0
03-2016	RP-71	RP-160488	3452			Maintenance CR for CA (Rel-12)	12.11.0
03-2016	RP-71	RP-160489	3454			Maintenance CR for DC (Rel-12)	12.11.0
03-2016	RP-71	RP-160489	3455			Maintenance CR for D2D (Rel-12)	12.11.0
03-2016	RP-71	RP-160489	3457r 1			CR: Correction of FRC for SDR test (Rel-12)	12.11.0
03-2016	RP-71	RP-160488	3472			CR of editorial change on PHICH group and Ng in Rel-12	12.11.0
2016/06	RP-72	RP-161141	3488		F	Correction on B39 coexistence spurious emission requirements	12.12.0
2016/06	RP-72	RP-161141	3490		F	Square brackets on B39 single carrier spurious emission requirements for protecting B3	12.12.0
2016/06	RP-72	RP-161141	3495		F	CSI requirements for 2DL FDD-TDD for UE Cat 3 (Rel 12)	12.12.0
2016/06	RP-72	RP-161141	3497		F	Wrong RMC description in overview table (Rel-12)	12.12.0
2016/06	RP-72	RP-161141	3529		F	Correction on UE category for MTC in TS 36.101	12.12.0
2016/06	RP-72	RP-161140	3534		F	ACS for CA Bandwidth Class D: Case 2 wanted signal power	12.12.0
2016/06	RP-72	RP-161140	3537		F	Maintenance CR for demodulation performance requirements (Rel-12)	12.12.0
2016/06	RP-72	RP-161141	3558	-	F	Corrections to 9.6.1.3 and 9.6.1.4 TDD FDD CQI Reporting test	12.12.0
2016/06	RP-72	RP-161141	3586	-	F	CR on Frequency bands for UE category 0	12.12.0
2016/06	RP-72	RP-161141	3613	-	F	CR: Maintenance CR for demodulation performance requirements (Rel-12)	12.12.0
2016/06	RP-72	RP-161141	3622	-	A	Editorial correction for TM4 MMSE-IRC PDSCH demodulation test	12.12.0
2016/09	RP-73	RP-161785	3643	-	F	Correct UE DL category for 256QAM demodulation	12.13.0
2016/09	RP-73	RP-161632	3654	-	A	Improving the single antenna port description in UL-MIMO clauses	12.13.0
2016/09	RP-73	RP-161784	3661	-	A	Correction of CA REFSENS harmonic formula	12.13.0
2016/09	RP-73	RP-161784	3670	-	A	CR: Update the power level setting for tests 8.3.1.2 and 8.3.2.3 (Rel-12)	12.13.0
2016/09	RP-73	RP-161634	3745	-	F	Removal of square brackets for Cat-0 REFSENS configuration	12.13.0
2016/09	RP-73	RP-161633	3763	-	A	CR for fixing power level for TM9 dual layer test in Rel-12	12.13.0
2016/09	RP-73	RP-161634	3774	-	F	2UL CA 5+17 correction	12.13.0
2016/09	RP-73	RP-161634	3792	-	F	Modification on E-UTRA Prose out of band blocking requirement	12.13.0
2016/09	RP-73	RP-161633	3797	-	F	Correction of OCNG	12.13.0
2016/09	RP-73	RP-161784	3802	-	F	CR: Correction of power parameter for demodulation tests	12.13.0
2016/09	RP-73	RP-161634	3822	-	F	Correction on subframe pair definition for PCMAX of DC	12.13.0
2016/09	RP-73	RP-161784	3825	-	F	Correction of CR Implementation error to 36.101	12.13.0
2016/09	RP-73	RP-161630	3828	-	F	Bracket removal for B3 and B39 UE co-existence	12.13.0
2016/12	RP-74	RP-162459	3874	2	F	Clarification on UE maximum output power	12.14.0
2016/12	RP-74	RP-162459	3899	1	B	CR for updating applicability rule for UE cat 9 Ues and DL Cat. 13 UEs in Rel-12	12.14.0
2016/12	RP-74	RP-162412	3925	-	F	UE to UE co-existence for B42 with 2ULs	12.14.0
2016/12	RP-74	RP-162415	3994	1	F	Correction to cell mapping for periodic CQI reporting on multiple cells	12.14.0
2016/12	RP-74	RP-162411	4020	-	A	RMCs and applicability of core RF requirements	12.14.0
2016/12	RP-74	RP-162411	4029	-	A	Correction of spurious emissions requirements for Band 9 range and intra-band CA	12.14.0

2016/12	RP-74	RP-162420	4038	-	F	Optional PCell indication	12.14.0
2016/12	RP-74	RP-162413	4063	1	A	Corrections to CA table reference and header	12.14.0
2016/12	RP-74	RP-162459	4075	1	F	Corrections of CA Refsens exceptions in 7.3.1A (Rel-12)	12.14.0
2016/12	RP-74	RP-162459	4079	1	F	DeltaRIB for SDL CA	12.14.0
2016/12	RP-74	RP-162459	4083	1	F	CR for fixing soft buffer management test for TDD-FDD CA in Rel-12	12.14.0
2016/12	RP-74	RP-162404	4089	1	F	Introduction of MSD requirement for IMD5 on band3 of CA_3A-8A 2UL CA	12.14.0
2016/12	RP-74	RP-162406	4100	-	A	Versioning indicator bit for NS_04 A-MPR table	12.14.0
2016/12	RP-74	RP-162420	4109	-	F	RF: Pb setting in power imbalance TCs (Rel-12)	12.14.0
2016/12	RP-74	RP-162420	4112	-	F	RF: Correction to RMC for UE Category 1 in CSI tests (Rel-12)	12.14.0
2016/12	RP-74	RP-162413	4116	-	F	RF: Beamforming model missing in chapter 9 TM9 receiver Type A tests (Rel-12)	12.14.0
2016/12	RP-74	RP-162459	4122	-	F	RF: Incorrect Number of EREGs per ECCE for special subframe mentioned for TC 8.7.4 (Rel-12)	12.14.0
2017/01	RP-74					Page header information update	12.14.1
2017/03	RP-75	RP-170585	4154		D	Split RMC overview table (R12)	12.15.0
2017/03	RP-75	RP-170583	4173	1	F	Correction to MPR table for intra-band 2UL CA	12.15.0
2017/03	RP-75	RP-170580	4211		A	Addition of missing note for bands 7 and 39 UE to UE co-ex	12.15.0
2017/03	RP-75	RP-170580	4215		A	Correction of CA_NS_06 non-contiguous resource allocation MPR formula	12.15.0
2017/03	RP-75	RP-170585	4230		F	Corrections for D2D resource configuration (Rel-12)	12.15.0
2017/03	RP-75	RP-170585	4241		F	CR for fixing requirement for soft buffer test for TDD-FDD CA in Rel-12	12.15.0
2017/06	RP-76	RP-171296	4307		F	Corrections for D2D FRCs	12.16.0
2017/06	RP-76	RP-171395	4316	1	F	Correction to SEM table for intra-band 2UL CA	12.16.0
2017/06	RP-76	RP-171297	4403		F	Correction of N_RB_agg for CA_41C in Table 7.3.1A-1	12.16.0
2017/06	RP-76	RP-171296	4410		F	Correction to Mapping of CQI Index to Modulation coding scheme for 256QAM	12.16.0
2017/06	RP-76	RP-171297	4471	2	F	Corrections for inCoverage configuration in ProSe direct communication (Rel-12)	12.16.0
2017/09	RP-77	RP-171965	4517	2	A	Correction of band 43 spurious emissions limit (Rel-12)	12.17.0
2017/09	RP-77	RP-171967	4542	1	F	Band 31 modification to add DTV protection Rel-12	12.17.0
2017/09	RP-77	RP-171964	4595		A	Correction for EPA delay profiles of r.m.s delay spread (Rel-12)	12.17.0
2017/09	RP-77	RP-171965	4632	2	F	Apply CA demodulation performance requirements with 30us timing difference between two CCs to intra-band non-contiguous CA case	12.17.0
2017/09	RP-77	RP-171966	4637		F	Update to CA_NS_04 SEM and additional spurious emissions	12.17.0
2017/12	RP-78	RP-172606	4805		F	Corrections on operating band table for CA (Rel-12)	12.18.0
2017/12	RP-78	RP-172606	4816	2	F	Corrections on intra-band and inter-band CA operating bands (Rel-12)	12.18.0
2017/12	RP-78	RP-172606	4824	1	F	CR for updating overview table for Sidelink (Rel-12)	12.18.0
2017/12	RP-78	RP-172605	4854		F	Update to A-MPR for CA_NS_04	12.18.0
2018-03	RAN#79	RP-180290	4918		F	Correction for CA CQI tests (R12)	12.19.0
2018-03	RAN#79	RP-180285	4944		A	PC2 for CA_41C REL-12	12.19.0
2018-03	RAN#79	RP-180290	4945		F	Adding note about timing difference for TDD CA (2Rx)	12.19.0
2018-06	RAN#80	RP-181108	4989		F	CA_NS_08 correction for TS 36.101 R12	12.20.0
2018-06	RAN#80	RP-181108	5006	1	F	Clarification of Transmission Modes for REFSEN test R12	12.20.0
2018-06	RAN#80	RP-181108	5010		F	Correction for CA CQI tests (R12)	12.20.0
2018-06	RAN#80	RP-181105	5018	1	F	Cat.F CR for UE-to-UE co-existence for Band 3 in Japan (Rel-12)	12.20.0
2018-06	RAN#80	RP-181106	5048		A	CR: Corrections for CSI tests (Rel-12)	12.20.0
2018-06	RAN#80	RP-181107	5111		A	Update to CA_NS_04 requirements	12.20.0
2018-06	RAN#80	RP-181108	5115		F	Update to NS_04 requirements	12.20.0
2018-09	RAN#81	RP-181909	5147	1	F	Correction on Table 6.6.3.2A-0 Requirements for uplink inter-band carrier aggregation (two bands)	12.21.0
2018-09	RAN#81	RP-181909	5156	1	F	Removal of square brackets for CA_4A-7A-12A	12.21.0
2018-09	RAN#81	RP-181908	5187	1	A	Correction on Table 7.3.1-3 Network signalling value for reference sensitivity	12.21.0
2018-12	RAN#82	RP-182379	5258	1	F	Correction to frequency of CA_4A-7A for MSD with inter-band 2UL	12.22.0
2018-12	RAN#82	RP-182379	5278		F	MCG/SCG Abbreviations in TS36.101 in rel-12	12.22.0
2019-03	RAN#83	RP-190411	5337	1	F	CR on protection Band 32 for Band 28 and corresponding band combinations	12.23.0
2019-12	RAN#86	RP-193043	5574		F	Correction to intraband contiguous CA out-of-band blocking table REL-12	12.24.0
2020-06	RAN#88	RP-200991	5623		F	CR: Updates to LTE CQI test cases 9.2.1.7 and 9.2.1.8 (Rel-12)	12.25.0
2021-03	RAN#91	RP-210111	5729	1	A	CR for 36.101: Corrections related to Band 24 regulatory updates	12.26.0
2021-06	RAN#92	RP-211092	5753		A	CR for updates related to LTE band 24 in 36.101 (Rel-12)	12.27.0
2021-06	RAN#92	RP-211092	5764	1	F	CR to TS 36.101[R12]: Addition of UE co-existence requirements	12.27.0

						for band 40	
2021-06	RAN#92	RP-211076	5778		F	CR: cleanup for square brackets (Rel-12)	12.27.0

History

Document history		
V12.5.0	November 2014	Publication
V12.6.0	April 2015	Publication
V12.7.0	May 2015	Publication
V12.8.0	September 2015	Publication
V12.9.0	October 2015	Publication
V12.10.1	April 2016	Publication
V12.11.0	May 2016	Publication
V12.12.0	September 2016	Publication
V12.13.0	December 2016	Publication
V12.14.1	March 2017	Publication
V12.15.0	April 2017	Publication
V12.16.0	August 2017	Publication
V12.17.0	November 2017	Publication
V12.18.0	January 2018	Publication
V12.19.0	April 2018	Publication
V12.20.0	October 2018	Publication
V12.21.0	January 2019	Publication
V12.22.0	May 2019	Publication
V12.23.0	May 2019	Publication
V12.24.0	February 2020	Publication
V12.25.0	August 2020	Publication
V12.26.0	May 2021	Publication
V12.27.0	September 2021	Publication