

ETSI TS 132 442 V8.0.0 (2009-01)

Technical Specification

**Digital cellular telecommunications system (Phase 2+);
Universal Mobile Telecommunications System (UMTS);
LTE;
Telecommunication management;
Trace Management Integration Reference Point (IRP):
Information Service (IS)
(3GPP TS 32.442 version 8.0.0 Release 8)**



Reference

RTS/TSGS-0532442v800

Keywords

GSM, LTE, UMTS

ETSI

650 Route des Lucioles
F-06921 Sophia Antipolis Cedex - FRANCE

Tel.: +33 4 92 94 42 00 Fax: +33 4 93 65 47 16

Siret N° 348 623 562 00017 - NAF 742 C
Association à but non lucratif enregistrée à la
Sous-Préfecture de Grasse (06) N° 7803/88

Important notice

Individual copies of the present document can be downloaded from:

<http://www.etsi.org>

The present document may be made available in more than one electronic version or in print. In any case of existing or perceived difference in contents between such versions, the reference version is the Portable Document Format (PDF). In case of dispute, the reference shall be the printing on ETSI printers of the PDF version kept on a specific network drive within ETSI Secretariat.

Users of the present document should be aware that the document may be subject to revision or change of status. Information on the current status of this and other ETSI documents is available at

<http://portal.etsi.org/tb/status/status.asp>

If you find errors in the present document, please send your comment to one of the following services:

http://portal.etsi.org/chaicor/ETSI_support.asp

Copyright Notification

No part may be reproduced except as authorized by written permission.
The copyright and the foregoing restriction extend to reproduction in all media.

© European Telecommunications Standards Institute 2009.
All rights reserved.

DECTTM, **PLUGTESTS**TM, **UMTS**TM, **TIPHON**TM, the TIPHON logo and the ETSI logo are Trade Marks of ETSI registered for the benefit of its Members.

3GPPTM is a Trade Mark of ETSI registered for the benefit of its Members and of the 3GPP Organizational Partners.

LTETM is a Trade Mark of ETSI currently being registered

for the benefit of its Members and of the 3GPP Organizational Partners.

GSM[®] and the GSM logo are Trade Marks registered and owned by the GSM Association.

Intellectual Property Rights

IPRs essential or potentially essential to the present document may have been declared to ETSI. The information pertaining to these essential IPRs, if any, is publicly available for **ETSI members and non-members**, and can be found in ETSI SR 000 314: "*Intellectual Property Rights (IPRs); Essential, or potentially Essential, IPRs notified to ETSI in respect of ETSI standards*", which is available from the ETSI Secretariat. Latest updates are available on the ETSI Web server (<http://webapp.etsi.org/IPR/home.asp>).

Pursuant to the ETSI IPR Policy, no investigation, including IPR searches, has been carried out by ETSI. No guarantee can be given as to the existence of other IPRs not referenced in ETSI SR 000 314 (or the updates on the ETSI Web server) which are, or may be, or may become, essential to the present document.

Foreword

This Technical Specification (TS) has been produced by ETSI 3rd Generation Partnership Project (3GPP).

The present document may refer to technical specifications or reports using their 3GPP identities, UMTS identities or GSM identities. These should be interpreted as being references to the corresponding ETSI deliverables.

The cross reference between GSM, UMTS, 3GPP and ETSI identities can be found under <http://webapp.etsi.org/key/queryform.asp>.

Contents

Intellectual Property Rights	2
Foreword.....	2
Foreword.....	5
Introduction	5
1 Scope	6
2 References	6
3 Definitions and abbreviations.....	6
3.1 Definitions	6
3.2 Abbreviations	7
4 System Overview	7
4.1 System context	7
4.2 Compliance rules.....	7
5 Information Object Classes	8
5.1 Imported information entities and local labels	8
5.2 Class diagram	8
5.2.1 Attributes and relationships	8
5.2.2 Inheritance	9
5.3 Information object class definitions	9
5.3.1 TraceJob.....	9
5.3.1.1 Definition	9
5.3.1.2 Attributes.....	10
5.3.1.3 Attribute constraints	10
5.3.2 TraceRecord.....	11
5.3.2.1 Definition.....	11
5.3.2.2 Attributes.....	11
5.3.3 TraceIRP	11
5.3.3.1 Definition	11
5.3.4 ManagedEntity.....	11
5.3.4.1 Definition	11
5.4 Information relationship definitions	12
5.4.1 relation-traceIRP-traceJob (M)	12
5.4.1.1 Definition	12
5.4.1.2 Roles	12
5.4.2 relation-traceJob-managedEntity (M)	12
5.4.2.1 Definition	12
5.4.2.2 Roles	12
5.4.3 relation-traceJob-traceRecord (M).....	12
5.4.3.1 Definition	12
5.4.3.2 Roles	12
5.5 Information attribute definitions.....	13
5.5.1 Definition and legal values	13
6 Interface Definition	14
6.1 Class diagram representing interfaces	14
6.2 Generic rules	14
6.3 TraceIRPManagement (M).....	15
6.3.1 Operation activateTraceJob (M).....	15
6.3.1.1 Definition	15
6.3.1.2 Input parameters.....	15
6.3.1.3 Output parameters	15
6.3.1.4 Pre-condition.....	15
6.3.1.5 Post-condition	17

6.3.1.6	Exceptions	17
6.3.1.7	Constraints	17
6.3.2	Operation deactivateTraceJob (M)	17
6.3.2.1	Definition	17
6.3.2.2	Input parameters	17
6.3.2.3	Output parameters	18
6.3.2.4	Pre-condition	18
6.3.2.4	Post-condition	18
6.3.2.6	Exceptions	18
6.3.3	Operation listTraceJob (M).....	18
6.3.3.1	Definition	18
6.3.3.2	Input parameters.....	18
6.3.3.3	Output parameters	19
6.3.3.4	Pre-condition.....	19
6.3.3.5	Post-condition	19
6.3.3.6	Exceptions	19
6.3.3.7	Constraints	19
6.3.4	Operation listActivatedTraceJobs (M).....	20
6.3.4.1	Definition	20
6.3.4.2	Input parameters.....	20
6.3.4.3	Output parameters	20
6.3.5	Notification notifyTraceRecordingSessionFailure (O)	20
6.3.5.1	Definition	20
6.3.5.2	Input parameters.....	20
6.3.5.3	Triggering event	20
6.3.5.3.1	From state	20
6.3.5.3.2	To state	20
6.3.6	Notification notifyTraceSessionLocalActivation (M)	21
6.3.6.1	Definition	21
6.3.6.2	Input parameters.....	21
6.3.6.3	Triggering event.....	21
6.3.6.3.1	From state	21
6.3.6.3.2	To state	21
6.3.7	Notification notifyTraceSessionIdentities (CM).....	21
6.3.7.1	Definition	21
6.3.7.2	Input parameters.....	22
6.3.7.3	Triggering event.....	22
6.3.7.3.1	From state	22
6.3.7.3.2	To state	22
6.3.7.4	Constraint	22
Annex A (informative): Change history		23
History		24

Foreword

This Technical Specification has been produced by the 3rd Generation Partnership Project (3GPP).

The contents of the present document are subject to continuing work within the TSG and may change following formal TSG approval. Should the TSG modify the contents of the present document, it will be re-released by the TSG with an identifying change of release date and an increase in version number as follows:

Version x.y.z

where:

- x the first digit:
 - 1 presented to TSG for information;
 - 2 presented to TSG for approval;
 - 3 or greater indicates TSG approved document under change control.
- y the second digit is incremented for all changes of substance, i.e. technical enhancements, corrections, updates, etc.
- z the third digit is incremented when editorial only changes have been incorporated in the document.

Introduction

The present document is part of a TS-family covering the 3rd Generation Partnership Project; Technical Specification Group Services and System Aspects; Telecommunication management; as identified below:

- 32.441 "Trace Management Integration Reference Point (IRP): Requirements".
- 32.442 "Trace Management Integration Reference Point (IRP): Information Service (IS)".**
- 32.443 "Trace Management Integration Reference Point (IRP): Common Object Request Broker Architecture (CORBA) Solution Set (SS)".
- 32.445 "Trace Management Integration Reference Point (IRP): eXtensible Markup Language (XML) file format definition".

The present document is part of a TS-family which describes the information service necessary for the Telecommunication Management (TM) of 3G systems. The TM principles and TM architecture are specified in 3GPP TS 32.101 [1] and 3GPP TS 32.102 [2].

Trace provides very detailed information on call level for a specific subscriber or MS. This data is an additional information source to Performance Measurements and allows deeper investigations in problems solving or in case of optimization.

1 Scope

2 References

The following documents contain provisions which, through reference in this text, constitute provisions of the present document.

- References are either specific (identified by date of publication, edition number, version number, etc.) or non-specific.
- For a specific reference, subsequent revisions do not apply.
- For a non-specific reference, the latest version applies. In the case of a reference to a 3GPP document (including a GSM document), a non-specific reference implicitly refers to the latest version of that document *in the same Release as the present document*.

- [1] 3GPP TS 32.101: "Telecommunication management; Principles and high level requirements".
- [2] 3GPP TS 32.102: "Telecommunication management; Architecture".
- [3] 3GPP TS 32.150: "Telecommunication management; Integration Reference Point (IRP) Concept and definitions".
- [4] 3GPP TS 32.152: "Telecommunication management; Integration Reference Point (IRP) Information Service (IS) Unified Modelling Language (UML) repertoire".
- [5] 3GPP TS 32.622: "Telecommunication management; Configuration Management (CM); Generic network resources Integration Reference Point (IRP); Network Resource Model (NRM)".
- [6] 3GPP TS 32.302: "Telecommunication management; Configuration Management (CM); Notification Integration Reference Point (IRP): Information Service (IS)".
- [7] 3GPP TS 32.342: "Telecommunication management; File Transfer (FT) Integration Reference Point (IRP): Information Service (IS)".
- [8] 3GPP TS 32.312: "Telecommunication management; Generic Integration Reference Point (IRP) management: Information Service (IS)".
- [9] 3GPP TS 32.422: "Telecommunication management; Subscriber and equipment trace; Trace control and configuration management".
- [10] 3GPP TS 32.602: "Telecommunication management; Configuration Management (CM); Basic CM Integration Reference Point (IRP): Information Service (IS)".

3 Definitions and abbreviations

3.1 Definitions

For the purposes of the present document, the terms and definitions given in 3GPP TS 32.101 [1], 3GPP TS 32.102 [2], 3GPP TS 32.150 [3] and the following apply:

IRPAgent: See 3GPP TS 32.102 [2].

IRPManager: See 3GPP TS 32.102 [2].

3.2 Abbreviations

For the purposes of the present document, the abbreviations given in 3GPP TS 32.101 [1], 3GPP TS 32.102 [2], 3GPP TS 32.150 [3] and the following apply:

IOC	Information Object Class
IRP	Integration Reference Point
IS	Information Service
OMG	Object Management Group
UML	Unified Modelling Language (OMG)

4 System Overview

4.1 System context

The general definition of the System Context for the present IRP is found in 3GPP TS 32.150 [3] subclause 4.7.

In addition, the set of related IRP(s) relevant to the present IRP is shown in the two diagrams below.

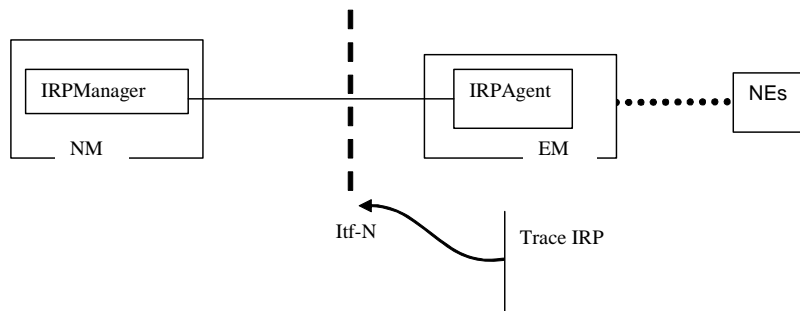

Figure 4.1.1: System Context A

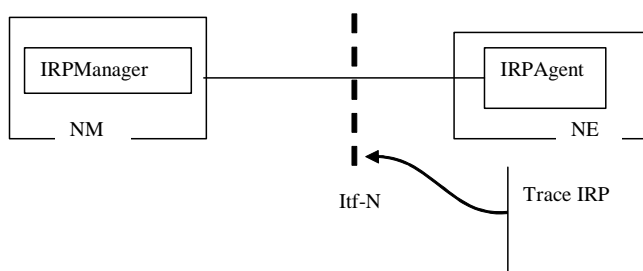

Figure 4.1.2: System Context B

4.2 Compliance rules

For general definitions of compliance rules related to qualifiers (Mandatory/Optional/Conditional) for *operations*, *notifications* and *parameters* (of operations and notifications) please refer to 3GPP TS 32.150 [3].

5 Information Object Classes

5.1 Imported information entities and local labels

Label reference	Local label
3GPP TS 32.622 [5], information object class, Top	Top
3GPP TS 32.622 [5], information object class, IRPAgent	IRPAgent
3GPP TS 32.622 [5], information object class, GenericIRP	GenericIRP
3GPP TS 32.302 [6], information object class, NotificationIRP	NotificationIRP
3GPP TS 32.342 [7], information object class, FileTransferIRP	FileTransferIRP
3GPP TS 32.602 [10], information object class, ManagedEntity	ManagedEntity

5.2 Class diagram

5.2.1 Attributes and relationships

This clause introduces the set of Information Object Classes (IOCs) that encapsulate information within the IRPAgent. The intent is to identify the information required for the TraceIRP implementation of its operations and notification emission. This clause provides the overview of all support object classes in UML. Subsequent clauses provide more detailed specification of various aspects of these support object classes.

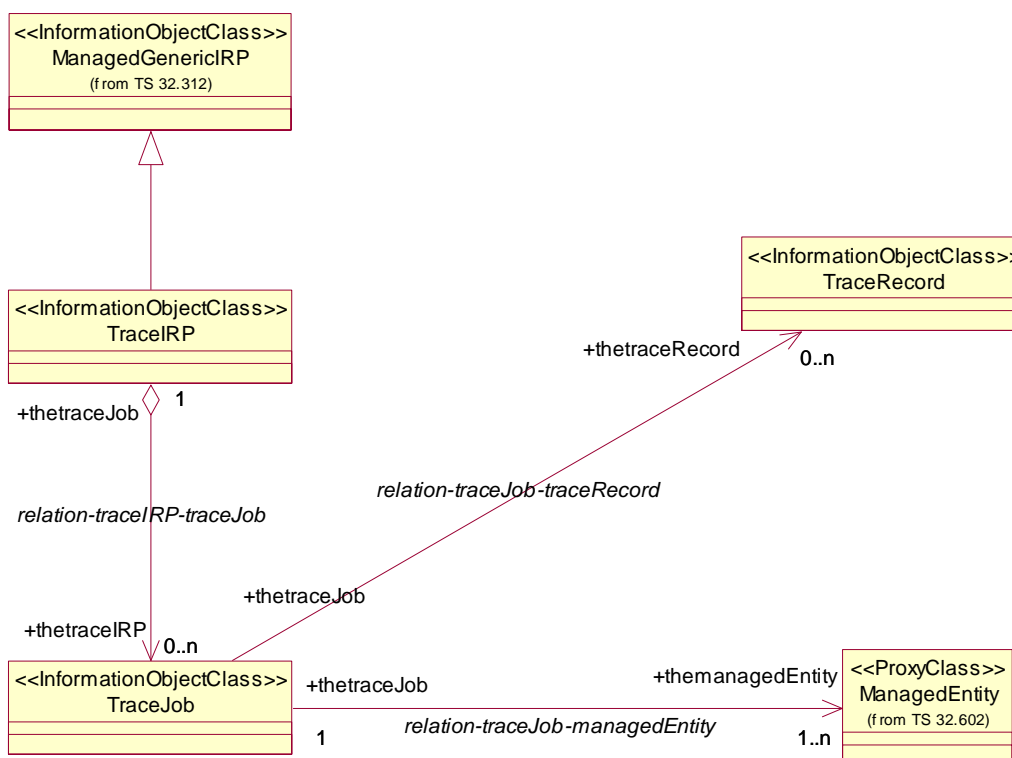

Figure 5.2.1: Information Object Class (IOC) UML diagram

5.2.2 Inheritance

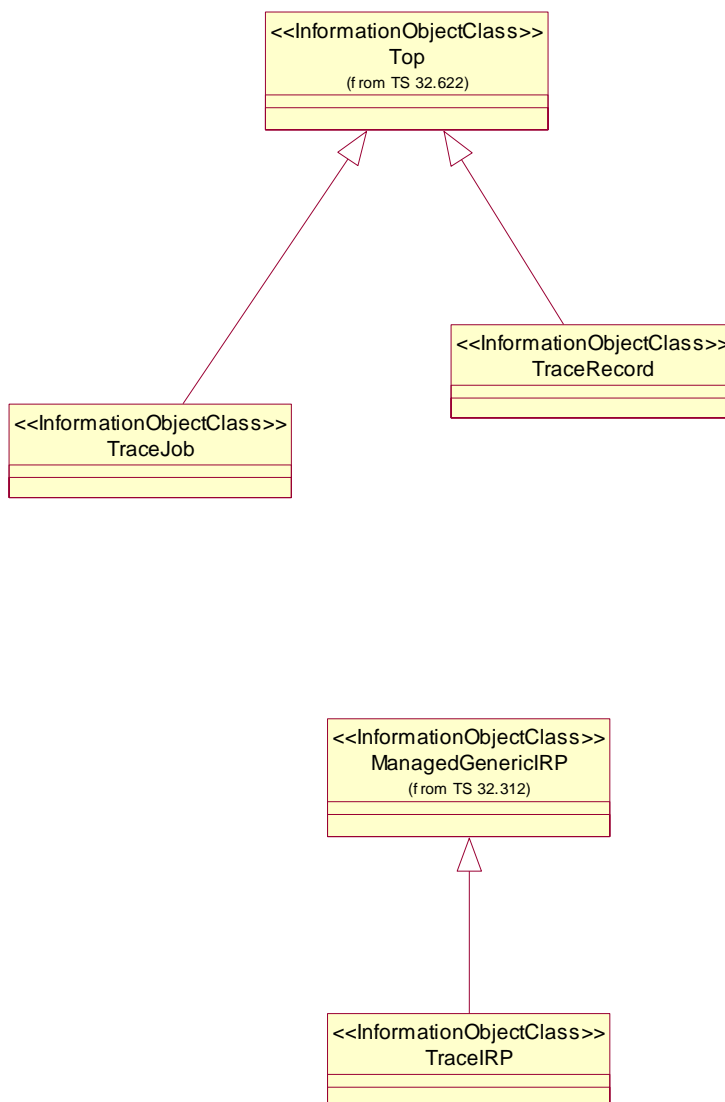

Figure 5.2.2: Information Object Class Inheritance UML Diagram

5.3 Information object class definitions

5.3.1 TraceJob

5.3.1.1 Definition

It represents a task that controls the Trace Sessions and collects the trace data (i.e. collects the `TraceRecord` of multiple `ManagedEntity` instances). The `TraceReference` is a unique ID, which identifies the Trace Session that has been created by the `TraceJob` and activated to one or multiple `ManagedEntity` instance(s).

When a `TraceJob` is created the following attributes cannot be modified via the Itf-N:

- `TraceReference`

- ListOfInterfaces
- ListofNeTypes
- TraceDepth
- TraceTarget
- TriggeringEvent

If for any reason the TraceIRP determines that a Trace Session has been activated in its ManagedEntity(ies) the TraceIRP shall emit the "noitfyTraceSessionLocalActivation" notification to the subscribed IRPManagers to inform the active Trace Sessions. The IRPManagers can decide whether they deactivate the Trace Session or keep the Trace Session active. (E.g. if the TraceReference is colliding with an existing TraceJob"s TraceReference, the IRPManager may decide to immediately deactivate the Trace Session in that ManagedEntity.)

The TraceJob shall use its information to activate and configure Trace Session(s) in the requested ManagedEntity instance(s). When the TraceIRP determines that there are available TraceRecord files, it shall emit a notification to all subscribed IRPManagers informing the availability of the files. The method and the notification of the available files is described in the File Transfer IRP (3GPP TS 32.342 [7]).

If a TraceJob receives an indication from one of its ManagedEntity that starting a Trace Recording Session is failed for any reason, the "notifyTraceRecordingSessionFailure" notification may be emitted to inform all subscribed IRPManagers that there was a Trace Recording Session that was not started in the ManagedEntity.

5.3.1.2 Attributes

Attribute name	Visibility	Support Qualifier	Read Qualifier	Write Qualifier
traceReference	+	M	M	-
listOfInterfaces	+	O	O	-
listOfNeTypes	+	CM	M	-
traceDepth	+	M	M	-
traceTarget	+	M	M	-
triggeringEvent	+	M	M	-
traceCollectionEntityAddress	+	M	M	-

5.3.1.3 Attribute constraints

The listofNeTypes attributes shall be present only for Signalling Based Activation.

The traceTarget shall be public ID in case of a Management Based Activation is done to an ScscfFunction.

The TraceTarget shall be cell only in case of the UTRAN cell traffic trace function.

The TraceTarget shall be E-UtranCell only in case of E-UTRAN cell traffic trace function. The traceTarget shall be either IMSI or IMEI(SV) if the Trace Session is activated to any of the following ManagedEntity(ies):

- HssFunction
- MscServerFunction
- SgsnFunction
- GgsnFunction
- BmscFunction
- RncFunction
- MmeFunction

The `traceTarget` shall be IMSI if the Trace Session is activated to a `ManagedEntity` playing a role of `SgwFunction`.

5.3.2 TraceRecord

5.3.2.1 Definition

`TraceRecord` is the representation of the files containing the logged information from the Trace Recording Sessions.

5.3.2.2 Attributes

Attribute name	Visibility	Support Qualifier	Read Qualifier	Write Qualifier
<code>fileName</code>	+	M	M	-

5.3.3 TraceIRP

5.3.3.1 Definition

`TraceIRP` is the representation of the trace management capabilities specified by the present document. This IOC inherits from `ManagedGenericIRP` IOC specified in 3GPP TS 32.312 [8].

5.3.4 ManagedEntity

5.3.4.1 Definition

In case of Signalling Based Activation the `ManagedEntity` represents the role that can be played by an instance of one of the following IOCs:

- `HssFunction`
- `MscServerFunction`
- `SgsnFunction`
- `MmeFunction`

In case of Management Based Activation the `ManagedEntity` represents the role that can be played by an instance of the following IOCs:

- `HssFunction`
- `MscServerFunction`
- `SgsnFunction`
- `GgsnFunction`
- `BmscFunction`
- `RncFunction`
- `CscfFunction`
- `MmeFunction`
- `SgwFunction`

In case of Cell Traffic Trace the ManagedEntity represents the role that can be played by an instance of the of the following IOCs:

- UtranCell
- E-UtranCell

5.4 Information relationship definitions

5.4.1 relation-traceIRP-traceJob (M)

5.4.1.1 Definition

This represents the relationship between TraceIRP and the TraceJob.

5.4.1.2 Roles

Name	Definition
theTraceIRP	It represents the TraceIRP
theTraceJobList	It represents the TraceJobList

5.4.2 relation-traceJob-managedEntity (M)

5.4.2.1 Definition

This represents the relationship between TraceJob and the ManagedEntity.

5.4.2.2 Roles

Name	Definition
theManagedEntity	The ManagedEntity, when playing this role, represents the actual network resource instance, where a Trace Session is activated.
theTraceJob	It represents the TraceJob

5.4.3 relation-traceJob-traceRecord (M)

5.4.3.1 Definition

This represents the relationship between TraceJob and the TraceRecord.

5.4.3.2 Roles

Name	Definition
theTraceJob	It represents the TraceJob
theTraceRecord	It represents the TraceRecord.

5.5 Information attribute definitions

5.5.1 Definition and legal values

Attribute Name	Definition	Legal Values
listOfInterfaces	It specifies the interfaces that needs to be traced in the given <code>ManagedEntityFunction</code>	See 3GPP TS 32.422 [9]
listOfNETypes	It specifies in which type of <code>ManagedFunction</code> the trace should be activated.	See 3GPP TS 32.422 [9]
traceCollectionEntityAddress	It specifies the address of the Trace Collection Entity within an <code>IRPManager</code> .	See 3GPP TS 32.422 [9]
traceDepth	It specifies the trace depth of the <code>ManagedEntityFunction</code> instances.	See 3GPP TS 32.422 [9]
traceReference	A globally unique identifier, which uniquely identifies the Trace Session that is created by the <code>TraceJob</code> .	Any positive integer value
traceTarget	It specifies what is the target object of the Trace	IMSI, IMEI, IMEISV, Public ID, Private ID, Cell(identified by its DN id)
triggeringEvent	It specifies the triggering event parameter of the trace session.	See 3GPP TS 32.422 [9]

6 Interface Definition

6.1 Class diagram representing interfaces

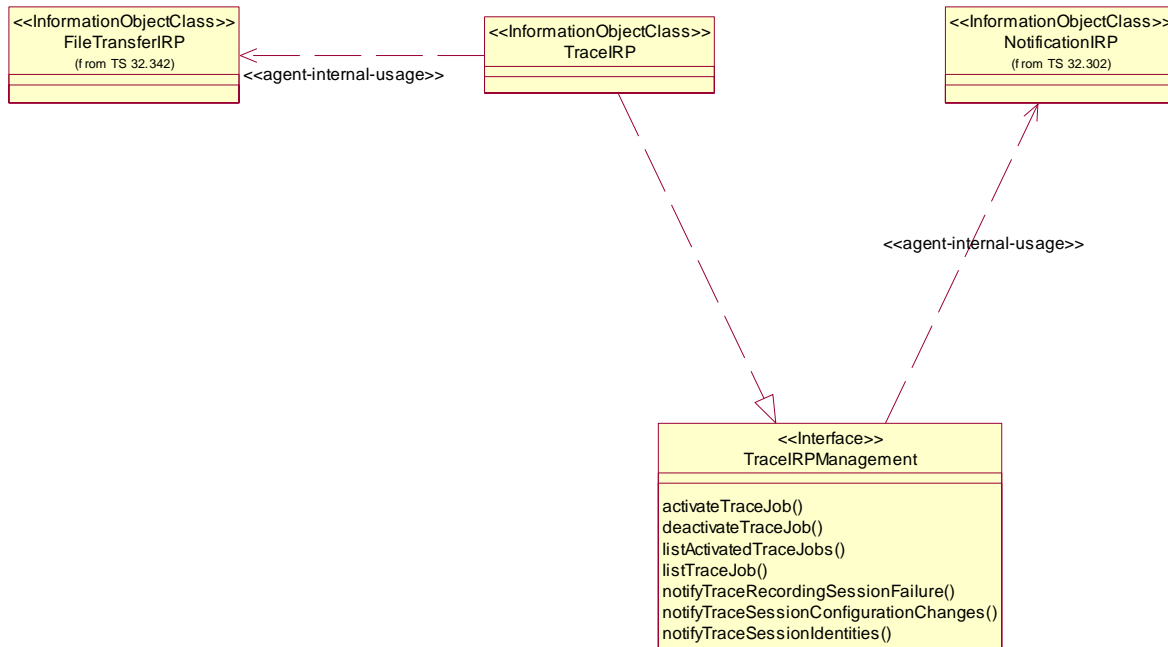

Figure 6.1: Class Diagram

6.2 Generic rules

- **Rule 1:** each operation with at least one input parameter supports a pre-condition `valid_input_parameter` which indicates that all input parameters shall be valid with regards to their information type. Additionally, each such operation supports an exception `operation_failed_invalid_input_parameter` which is raised when pre-condition `valid_input_parameter` is false. The exception has the same entry and exit state.
- **Rule 2:** each operation with at least one optional input parameter supports a set of pre-conditions `supported_optional_input_parameter_xxx` where "xxx" is the name of the optional input parameter and the pre-condition indicates that the operation supports the named optional input parameter. Additionally, each such operation supports an exception `operation_failed_unsupported_optional_input_parameter_xxx` which is raised when (a) the pre-condition `supported_optional_input_parameter_xxx` is false and (b) the named optional input parameter is carrying information. The exception has the same entry and exit state.
- **Rule 3:** each operation shall support a generic exception `operation_failed_internal_problem` which is raised when an internal problem occurs and that the operation cannot be completed. The exception has the same entry and exit state.

NOTE: These rules are mapped at the solution set level. Pre-conditions and exceptions, generated by these rules, need not appear explicitly in the present document.

6.3 TraceIRPManagement (M)

6.3.1 Operation activateTraceJob (M)

6.3.1.1 Definition

This operation support IPRManager"s request to create a TraceJob through Itf-N.

Once the TraceJob has been created, the attributes of the TraceJob will not be modified during the lifetime of the TraceJob.

One TraceJob can manage Trace Sessions in one or more ManagedEntity.

6.3.1.2 Input parameters

Parameter Name	Qualifier	Information type	Comment
iOCInstance	M	ManagedEntity.objectInstance	It specifies the DN of ManagedEntity instance where Trace Session is to be activated.
listOfInterfaces	O	TraceJob.listOfInterfaces	
listOfNeTypes	CM	TraceJob.listOfNeTypes	It specifies the type of ManagedFunctions.
traceDepth	M	TraceJob.traceDepth	It shows the traceDepth set to the Trace Session.
traceReference	M	TraceJob.traceReference	It identifies the TraceSession.
traceTarget	M	TraceJob.traceTarget	It specifies whether the trace shall be activated by IMSI, IMEI(SV), Public ID, Cell(identified by its DN id).
triggeringEvent	CO	TraceJob.triggeringEvent	
traceCollectionEntityAddress	CM	TraceJob.traceCollectionEntityAddress	It specifies the address to the Trace Collection Entity that is associated to the TraceJob. See 3GPP TS 32.422 [9].

6.3.1.3 Output parameters

Parameter Name	Qualifier	Matching Information	Comment
status	M	ENUM (Success, Failure, PartialSuccess)	
unsupportedList	M	List of <ManagedEntity, TraceDepth, ListOfInterfaces, TraceTarget, reason)	It specifies what attributes are not supported when a Trace Session is activated. The list can contain one or all of the elements and relevant only for error cases.

6.3.1.4 Pre-condition

validTraceReference AND validTraceDepth AND validTraceTarget

Assertion Name	Definition
validTraceDepth	The traceDepth input parameter is valid.
validTraceReference	The traceReference given is not matching to any existing traceReference value in the activated TraceJobs.
validTraceTarget	The traceTarget input parameter is valid.

6.3.1.5 Post-condition

traceSessionActivated

Assertion Name	Definition
traceSessionActivated	The Trace Session identified by the traceReference is activated in the given ManagedEntity instances.

6.3.1.6 Exceptions

Exception Name	Definition
invalidTraceDepth	Condition: (validTraceDepth) is false. Returned Information: output parameter status is set to "Failure". Exit state: Entry State.
invalidTraceTarget	Condition: (validTraceTarget) is false. Returned Information: output parameter status is set to "Failure". Exit state: Entry State.
notuniqueTraceReference	Condition: (validTraceReference) is false. Returned Information: output parameter status is set to "Failure". Exit state: Entry State.

6.3.1.7 Constraints

Name	Definition
listOfNeTypes	It is a Signalling Based Activated trace that is requested.
traceCollectionEntityAddress CM qualifier	Tracing is performed in EPS

6.3.2 Operation deactivateTraceJob (M)

6.3.2.1 Definition

This operation supports IPRManager"s request to stop a TraceJob through Itf-N. When this operation is received in the TraceIRP the TraceJob shall deactivate the requested Trace Session in the requested ManagedEntity instances.

6.3.2.2 Input parameters

Parameter Name	Qualifier	Information type	Comment
traceReference	M	TraceJob.traceReference	This is a unique ID of the TraceJob
traceTarget	M	TraceJob.traceTarget	It specifies whether the trace shall be deactivated by IMSI, IMEI(SV), Public ID, Cell(identified by its DN id).

6.3.2.3 Output parameters

Parameter Name	Qualifier	Matching Information	Comment
status	M	ENUM (Success, Failure)	The operation may fail because of a specified or an unspecified reason.
traceRecordingSessionReference	CM		This would indicate if a Trace Recording Session is ongoing when the deactivation command has been given.

6.3.2.4 Pre-condition

validTraceReference

Assertion Name	Definition
validTraceReference	The TraceReference input parameter is valid, which means that the TraceIRP is aware of such TraceJob, which has this traceReference value and is aware of the ManagedEntity holding such Trace Session.

6.3.2.4 Post-condition

TraceSessionisdeactivated

Assertion Name	Definition
TraceSessionisdeactivate	The Trace Session identified by the traceReference is deactivated in the requested ManagedEntity instance and the TraceJob is stopped.

6.3.2.6 Exceptions

Exception Name	Definition
notuniqueTraceReference	Condition: (validTraceReference) is false. Returned Information: output parameter status is set to "Failure". Exit state: Entry State.

6.3.3 Operation listTraceJob (M)

6.3.3.1 Definition

This operation support IPRManager"s request to list the parameters of a specific TraceJob through Itf-N.

6.3.3.2 Input parameters

Parameter Name	Qualifier	Information type	Comment
traceReference	M	TraceJob.traceReference	It specifies the Trace Session that is requested for interrogation.

6.3.3.3 Output parameters

Parameter Name	Qualifier	Matching Information	Comment
iOCInstance	M	ManagedElement.objectInstance	It specifies the DN of ManagedElement instance where a Trace Session is activated.
listOfInterfaces	O	TraceJob.listOfInterfaces	It specifies the list of interfaces trace control and configuration parameter that is associated with the TraceJob. See 3GPP TS 32.422 [9]
Status	M	ENUM (Success, Failure)	The operation may fail because of a specified or an unspecified reason.
traceDepth	M	TraceJob.traceDepth	It shows the traceDepth trace control and configuration parameter that is associated to the TraceJob.
traceRecordingSessionReference	CM		This would indicate if a Trace Recording Session is ongoing when the deactivation command has been given.
traceTarget	M	TraceJob.traceTarget	It specifies whether the Trace Session was activated by IMSI, IMEI(SV), Public ID, Cell(identified by its DN id).
triggeringEvent	O	TraceJob.triggeringEvent	It specifies the triggering event trace control and configuration parameter that is associated to the TraceJob. See 3GPP TS 32.422 [9].
traceCollectionEntityAddress	CM	TraceJob.traceCollectionEntityAddress	It specifies the address to the Trace Collection Entity that is associated to the TraceJob. See 3GPP TS 32.422 [9].

6.3.3.4 Pre-condition

validTraceReference

Assertion Name	Definition
validTraceReference	The traceReference input parameter is valid, which means that the TraceIRP is aware of such TraceJob, which has this traceReference value and is aware of the ManagedEntity holding such Trace Session.

6.3.3.5 Post-condition

TraceSessionFound

Assertion Name	Definition
TraceSessionFound	The TraceIRP has found the requested TraceJob with the traceReference and can read the configured parameters.

6.3.3.6 Exceptions

Exception Name	Definition
notuniqueTraceReference	Condition: (validTraceReference) is false. Returned Information: output parameter status is set to "Failure". Exit state: Entry State.

6.3.3.7 Constraints

Name	Definition
traceCollectionEntityAddress CM qualifier	Tracing is performed in EPS

6.3.4 Operation listActivatedTraceJobs (M)

6.3.4.1 Definition

This operation support IPRManager"s request to list all the activated TraceJobs through Itf-N.

6.3.4.2 Input parameters

No input parameters for this operation.

6.3.4.3 Output parameters

Parameter Name	Qualifier	Matching Information	Comment
traceReferenceList	M	List of < TraceJob.traceReference.objectinstance >	The TraceReferenceList provides the identification of each activated Trace Session. If no TraceReference can be found, then this list is empty and status is "Success"
status	M	ENUM (Success, Failure)	The operation may fail because of a specified or an unspecified reason.

6.3.5 Notification notifyTraceRecordingSessionFailure (O)

6.3.5.1 Definition

The TraceIRP notifies all subscribed IRPManagers and the Trace Collection Entity (if its address is provided) if a Trace Recording Session in a ManagedEntity has not been started due to any problem.

6.3.5.2 Input parameters

Parameter Name	Qualifiers	Matching Information	Comment
objectClass	M,Y	TraceIRP.objectClass	Notification header
objectInstance	M,Y	TraceIRP.objectInstance	Notification header
eventTime	M,Y	--	Notification header
notificationType	M,Y	"notifyTraceRecordingSessionFailure"	Notification header
systemDN	M,Y	--	Notification header
notificationID	O,Y	--	Notification header
traceRecordingSessionReference	O,N	--	The Trace Recording Session Reference may be visible only in signalling based activation.
traceReference	M,Y	TraceJob.traceReference	
reason	O,N	--	

6.3.5.3 Triggering event

6.3.5.3.1 From state

internalProblemInManagedEntity

Assertion Name	Definition
internalProblemInManagedEntity	Because of an internal problem the ManagedEntity cannot start a Trace Recording Session.

6.3.5.3.2 To state

newNotificationReported

Assertion Name	Definition
newNotificationReported	The " notifyTraceRecordingSessionFailure " notification is emitted to the subscribed IRPManager(s).

6.3.6 Notification notifyTraceSessionLocalActivation (M)

6.3.6.1 Definition

The TraceIRP notifies all subscribed IRPManagers if a Trace Session is configured by the Element Manager.

6.3.6.2 Input parameters

Parameter Name	Qualifiers	Matching Information	Comment
objectClass	M,Y	TraceIRP.objectClass	Notification header
objectInstance	M,Y	TraceIRP.objectInstance	Notification header
eventTime	M,Y	--	Notification header
notificationType	M,Y	"notifyTraceSessionLocalActivation"	Notification header
systemDN	M,Y	--	Notification header
notificationID	O,Y	--	Notification header
traceReference	M,Y	TraceJob.traceReference	
traceTarget	M,Y	TraceJob.traceTarget	
iOCInstance	M,Y	ManagedEntity.objectInstance	

6.3.6.3 Triggering event

6.3.6.3.1 From state

unknownTraceReference

Assertion Name	Definition
unknownTraceReference	The TraceIRP has detected a traceReference associated to a Trace Session in a ManagedEntity that is not initiated via the Itf-N.

6.3.6.3.2 To state

newNotificationReported

Assertion Name	Definition
newNotificationReported	The " notifyTraceSessionLocalActivation " notification is emitted to the subscribed IRPManager(s).

6.3.7 Notification notifyTraceSessionIdentities (CM)

6.3.7.1 Definition

The TraceIRP or the MmeFunction notifies the Trace Collection Entity about the identities of the subscriber and Equipment in case of tracing a session in E-UTRAN only.

6.3.7.2 Input parameters

Parameter Name	Qualifiers	Matching Information	Comment
objectClass	M,Y	TraceIRP.objectClass, or MmeFunction.objectClass	Notification header
objectInstance	M,Y	TraceIRP.objectInstance, or MmeFunction.objectClass	Notification header
eventTime	M,Y	--	Notification header
notificationType	M,Y	"notifyTraceSessionIds"	Notification header
systemDN	M,Y	--	Notification header
notificationID	O,Y	--	Notification header
traceReference	M,Y	TraceJob.traceReference	
traceRecordingSessionReference	M,Y	TraceJob.traceRecordingSessionReference	
traceTarget	M,Y	TraceJob.traceTarget	

6.3.7.3 Triggering event

6.3.7.3.1 From state

FFS

Assertion Name	Definition
FFS	FFS

6.3.7.3.2 To state

FFS

Assertion Name	Definition
FFS	FFS

6.3.7.4 Constraint

Name	Definition
notifyTraceSessionIdentities Notification CM qualifier	Tracing is performed only in E-UTRAN

Annex A (informative): Change history

Change history								
Date	TSG #	TSG Doc.	CR	Rev	Subject/Comment	Cat	Old	New
Apr 2007	S5_52	S5-070445	--	--	Submitted by SA5 prior SA#36 for Information with the intention to get SA#36 Rel-7 Approval for this TS and the CORBA Solution Set TS 32.443	--	1.0.0	
Jun 2007	SP-36	SP-070288	--	--	Submitted to SA#36 for Approval	--	1.0.0	7.0.0
Mar 2008	SP-39	SP-080058	0001	--	Standardize the DN id of UTRAN cell as the identification for the trace target in case of cell traffic trace	F	7.0.0	7.1.0
Dec 2008	SP-42	SP-080846	0002	--	Introducing EPS in Subscriber and Equipment Trace	C	7.1.0	8.0.0

History

Document history		
V8.0.0	January 2009	Publication