

# ETSI TS 132 253 V15.0.0 (2018-07)



**Universal Mobile Telecommunications System (UMTS);  
LTE;  
Digital cellular telecommunications system (Phase 2+) (GSM);  
Telecommunication management;  
Charging management;  
Control Plane (CP) data transfer domain charging  
(3GPP TS 32.253 version 15.0.0 Release 15)**



---

**Reference**

RTS/TSGS-0532253vf00

---

**Keywords**

GSM,LTE,UMTS

**ETSI**

650 Route des Lucioles  
F-06921 Sophia Antipolis Cedex - FRANCE

Tel.: +33 4 92 94 42 00 Fax: +33 4 93 65 47 16

Siret N° 348 623 562 00017 - NAF 742 C  
Association à but non lucratif enregistrée à la  
Sous-Préfecture de Grasse (06) N° 7803/88

---

**Important notice**

The present document can be downloaded from:

<http://www.etsi.org/standards-search>

The present document may be made available in electronic versions and/or in print. The content of any electronic and/or print versions of the present document shall not be modified without the prior written authorization of ETSI. In case of any existing or perceived difference in contents between such versions and/or in print, the only prevailing document is the print of the Portable Document Format (PDF) version kept on a specific network drive within ETSI Secretariat.

Users of the present document should be aware that the document may be subject to revision or change of status.

Information on the current status of this and other ETSI documents is available at

<https://portal.etsi.org/TB/ETSIDeliverableStatus.aspx>

If you find errors in the present document, please send your comment to one of the following services:

<https://portal.etsi.org/People/CommiteeSupportStaff.aspx>

---

**Copyright Notification**

No part may be reproduced or utilized in any form or by any means, electronic or mechanical, including photocopying and microfilm except as authorized by written permission of ETSI.

The content of the PDF version shall not be modified without the written authorization of ETSI.

The copyright and the foregoing restriction extend to reproduction in all media.

© ETSI 2018.

All rights reserved.

**DECT™**, **PLUGTESTS™**, **UMTS™** and the ETSI logo are trademarks of ETSI registered for the benefit of its Members.  
**3GPP™** and **LTE™** are trademarks of ETSI registered for the benefit of its Members and  
of the 3GPP Organizational Partners.

**oneM2M** logo is protected for the benefit of its Members.

**GSM®** and the GSM logo are trademarks registered and owned by the GSM Association.

---

# Intellectual Property Rights

## Essential patents

IPRs essential or potentially essential to normative deliverables may have been declared to ETSI. The information pertaining to these essential IPRs, if any, is publicly available for **ETSI members and non-members**, and can be found in ETSI SR 000 314: *"Intellectual Property Rights (IPRs); Essential, or potentially Essential, IPRs notified to ETSI in respect of ETSI standards"*, which is available from the ETSI Secretariat. Latest updates are available on the ETSI Web server (<https://ipr.etsi.org/>).

Pursuant to the ETSI IPR Policy, no investigation, including IPR searches, has been carried out by ETSI. No guarantee can be given as to the existence of other IPRs not referenced in ETSI SR 000 314 (or the updates on the ETSI Web server) which are, or may be, or may become, essential to the present document.

## Trademarks

The present document may include trademarks and/or tradenames which are asserted and/or registered by their owners. ETSI claims no ownership of these except for any which are indicated as being the property of ETSI, and conveys no right to use or reproduce any trademark and/or tradename. Mention of those trademarks in the present document does not constitute an endorsement by ETSI of products, services or organizations associated with those trademarks.

---

# Foreword

This Technical Specification (TS) has been produced by ETSI 3rd Generation Partnership Project (3GPP).

The present document may refer to technical specifications or reports using their 3GPP identities, UMTS identities or GSM identities. These should be interpreted as being references to the corresponding ETSI deliverables.

The cross reference between GSM, UMTS, 3GPP and ETSI identities can be found under <http://webapp.etsi.org/key/queryform.asp>.

---

# Modal verbs terminology

In the present document "**shall**", "**shall not**", "**should**", "**should not**", "**may**", "**need not**", "**will**", "**will not**", "**can**" and "**cannot**" are to be interpreted as described in clause 3.2 of the [ETSI Drafting Rules](#) (Verbal forms for the expression of provisions).

"**must**" and "**must not**" are **NOT** allowed in ETSI deliverables except when used in direct citation.

# Contents

Intellectual Property Rights .....	2
Foreword.....	2
Modal verbs terminology.....	2
Foreword.....	5
1 Scope .....	6
2 References .....	6
3 Definitions, symbols and abbreviations .....	7
3.1 Definitions .....	7
3.2 Symbols.....	7
3.3 Abbreviations .....	8
4 Architecture considerations .....	8
4.1 High-level CP data transfer architecture .....	8
4.2 CP data transfer domain offline charging architecture .....	10
4.3 CP data transfer domain online charging architecture.....	11
5 CP data transfer domain charging principles and scenarios.....	11
5.1 CP data transfer domain charging principles.....	11
5.2 CP data transfer domain offline charging scenarios .....	12
5.2.1 Basic principles.....	12
5.2.2 Rf message flows .....	13
5.2.2.1 Triggers for charging events from CPCN .....	13
5.2.2.2 SCEF specific triggers for charging events.....	13
5.2.2.3 IWF-SCEF specific triggers for charging events .....	14
5.2.2.4 MME specific triggers for charging events.....	14
5.2.3 CDR generation .....	14
5.2.3.1 Introduction.....	14
5.2.3.2 Triggers for CPDT-SCE-CDR creation and closure .....	14
5.2.3.2.1 General .....	14
5.2.3.2.2 Triggers for CPDT-SCE-CDR charging information addition.....	14
5.2.3.2.3 Triggers for CPDT-SCE-CDR closure .....	15
5.2.3.3 Triggers for CPDT-SNN-CDR creation and closure - IWK-SCEF.....	15
5.2.3.3.1 General .....	15
5.2.3.3.2 Triggers for CPDT-SNN-CDR charging information addition - IWK-SCEF .....	16
5.2.3.3.3 Triggers for CPDT-SNN-CDR closure - IWK-SCEF .....	16
5.2.3.4 Triggers for CPDT-SNN-CDR creation and closure - MME.....	16
5.2.3.4.1 General .....	16
5.2.3.4.2 Triggers for CPDT-SNN-CDR charging information addition - MME.....	17
5.2.3.4.3 Triggers for CPDT-SNN-CDR closure - MME.....	17
5.2.4 Ga record transfer flows .....	17
5.2.5 Bx CDR file transfer .....	17
5.3 CP data transfer domain online charging scenarios.....	18
5.3.1 Basic principles.....	18
5.3.2 Ro message flows .....	18
6. Definition of charging information .....	18
6.1 Data description for CP data transfer offline charging .....	18
6.1.1 Rf message contents.....	18
6.1.1.1 General .....	18
6.1.1.2 Charging data request message .....	18
6.1.1.3 Charging data response message.....	19
6.1.2 Ga message contents .....	19
6.1.3 CDR description on the B <sub>cp</sub> interface.....	19
6.1.3.1 General .....	19
6.1.3.2 SCEF Control Plane data transfer charging data (CPDT-SCE-CDR).....	19

6.1.3.3	Serving Network Control Plane data transfer charging data for IWK-SCEF/MME (CPDT-SNN-CDR) .....	20
6.1.3.4	NIDD submission.....	21
6.2	Data description for CP data transfer online charging.....	22
6.2.1	Ro message contents .....	22
6.3	CP data transfer charging specific parameters.....	23
6.3.1	Definition of CP data transfer charging information .....	23
6.3.1.1	CP data transfer charging information assignment for Service Information .....	23
6.3.1.2	Definition of the CP data transfer Information.....	24
6.3.2	Detailed message format for offline charging.....	24
6.3.3	Detailed message format for online charging .....	25
6.4	Bindings for CP data transfer offline charging.....	25
<b>Annex A (normative):</b>	<b>Charging characteristics .....</b>	<b>27</b>
A.1	General .....	27
<b>Annex B (informative):</b>	<b>Change history .....</b>	<b>28</b>
History .....		29

---

# Foreword

This Technical Specification has been produced by the 3rd Generation Partnership Project (3GPP).

The contents of the present document are subject to continuing work within the TSG and may change following formal TSG approval. Should the TSG modify the contents of the present document, it will be re-released by the TSG with an identifying change of release date and an increase in version number as follows:

Version x.y.z

where:

- x the first digit:
  - 1 presented to TSG for information;
  - 2 presented to TSG for approval;
  - 3 or greater indicates TSG approved document under change control.
- y the second digit is incremented for all changes of substance, i.e. technical enhancements, corrections, updates, etc.
- z the third digit is incremented when editorial only changes have been incorporated in the document.

---

# 1 Scope

The present document is part of a series of documents that specify charging functionality and charging management in GSM/UMTS/LTE networks. The GSM/UMTS/LTE core network charging architecture and principles are specified in TS 32.240 [1], which provides an umbrella for other charging management TSs that specify:

- the content of the CDRs per domain / subsystem / service (offline charging);
- the content of real-time charging messages per domain / subsystem / service (online charging);
- the functionality of online and offline charging for those domains / subsystems / services;
- the interfaces that are used in the charging framework to transfer the charging information (i.e. CDRs or charging events).

The complete document structure for these TSs is defined in TS 32.240 [1].

The present document specifies the offline and online charging description for Control Plane (CP) data transfer domain, based on the functional stage 2 description in TS 23.682 [243] for Non-IP Data Delivery (NIDD) using SCEF procedures. This charging description includes the offline and online charging architecture and scenarios specific to Control Plane (CP) data transfer domain, as well as the mapping of the common 3GPP charging architecture specified in TS 32.240 [1] onto the Control Plane (CP) data transfer domain. It further specifies the structure and content of the CDRs for offline charging. The present document is related to other 3GPP charging TSs as follows:

- The common 3GPP charging architecture is specified in TS 32.240 [1].
- The parameters, abstract syntax and encoding rules for the CDRs are specified in TS 32.298 [51].
- A transaction based mechanism for the transfer of CDRs within the network is specified in TS 32.295 [54].
- The file based mechanism used to transfer the CDRs from the network to the operator's billing domain (e.g. the billing system or a mediation device) is specified in TS 32.297 [52].
- The 3GPP Diameter application that is used for Control Plane (CP) data transfer domain offline and online charging is specified in TS 32.299 [50].

Control Plane (CP) data transfer is also provided by Short Message Service (SMS), for which charging functionalities are not specified in the present document. SMS charging functionality is defined for Circuit Switched domain in TS 32.250 [10], for Packet Switched domain in TS 32.251 [11] and for SMS Nodes in TS 32.274 [34].

---

# 2 References

The following documents contain provisions which, through reference in this text, constitute provisions of the present document.

- References are either specific (identified by date of publication, edition number, version number, etc.) or non-specific.
- For a specific reference, subsequent revisions do not apply.
- For a non-specific reference, the latest version applies. In the case of a reference to a 3GPP document (including a GSM document), a non-specific reference implicitly refers to the latest version of that document *in the same Release as the present document*.

[1] 3GPP TS 32.240: "Telecommunication management; Charging management; Charging architecture and principles".

[2] - [9] Void.

[10] 3GPP TS 32.250: "Telecommunication management; Charging management; Circuit Switched (CS) domain charging".

[11] 3GPP TS 32.251: "Telecommunication management; Charging management; Packet Switched (PS) domain charging".

[12] - [19]	Void.
[20]	3GPP TS 32.260: "Telecommunication management; Charging management; IP Multimedia Subsystem (IMS) charging".
[20] - [33]	Void.
[34]	3GPP TS 32.274: "Telecommunication management; Charging management; Short Message Service (SMS) charging".
[35] - [49]	Void.
[50]	3GPP TS 32.299: "Telecommunication management; Charging management; Diameter charging application".
[51]	3GPP TS 32.298: "Telecommunication management; Charging management; Charging Data Record (CDR) parameter description".
[52]	3GPP TS 32.297: "Telecommunication management; Charging management; Charging Data Record (CDR) file format and transfer".
[53]	Void.
[54]	3GPP TS 32.295: "Telecommunication management; Charging management; Charging Data Record (CDR) transfer".
[55] - [99]	Void.
[100]	3GPP TR 21.905: "Vocabulary for 3GPP Specifications".
[101] - [199]	Void
[200] - [206]	Void
[207]	3GPP TS 29.061: "Interworking between the Public Land Mobile Network (PLMN) supporting packet based services and Packet Data Networks (PDN)".
[208] - [242]	Void
[243]	3GPP TS 23.682: "Architecture enhancements to facilitate communications with packet data networks and applications".
[244] - [299]	Void
[300] - [399]	Void.
[400] - [499]	Void.
[500] - [599]	Void.

---

## 3 Definitions, symbols and abbreviations

### 3.1 Definitions

For the purposes of the present document, the terms and definitions given in 3GPP TR 21.905 [100] and the following apply. A term defined in the present document takes precedence over the definition of the same term, if any, in either 3GPP TR 21.905 [100].

### 3.2 Symbols

For the purposes of the present document, the following symbols apply:

Bcp	Reference point for the CDR file transfer from CP data transfer CGF to the BD.
Ga	Reference point for CDR transfer between a CDF and the CGF.
Rf	Offline charging reference point between a MME/SCEF/IWK-SCEF and the CDF.



S6t	Reference point between the SCEF and the HSS.
T6a	Reference point between the SCEF and the serving MME.
T6ai	Reference point between the IWK-SCEF and the serving MME.
T7	Reference point between the IWK-SCEF and the serving SCEF.

### 3.3 Abbreviations

For the purposes of the present document, the abbreviations given in 3GPP TR 21.905 [100] and the following apply. An abbreviation defined in the present document takes precedence over the definition of the same abbreviation, if any, in 3GPP TR 21.905 [100].

BD	Billing Domain
CDF	Charging Data Function
CGF	Charging Gateway Function
CIoT	Cellular Internet of Things
CP	Control Plane
CPCN	Control Plane data transfer Charging Node (MME, SCEF, IWK-SCEF)
CPDT	Control Plane Data Transfer
CTF	Charging Trigger Function
IE	Information Element
IWK-SCEF	Interworking SCEF
NE	Network Element
NIDD	Non-IP Data Delivery
SCEF	Service Capability Exposure Function

---

## 4 Architecture considerations

### 4.1 High-level CP data transfer architecture

The overall architecture for Service Capability Exposure which enables the 3GPP network to securely expose its services and capabilities provided by 3GPP network interfaces to external 3rd party service provider applications is defined in 3GPP TS 23.682 [243], and figure 4.1.1 is an excerpt highlighting relevant 3GPP Nodes involved for Non-IP Data Delivery (NIDD) between the UE and the SCS/AS.

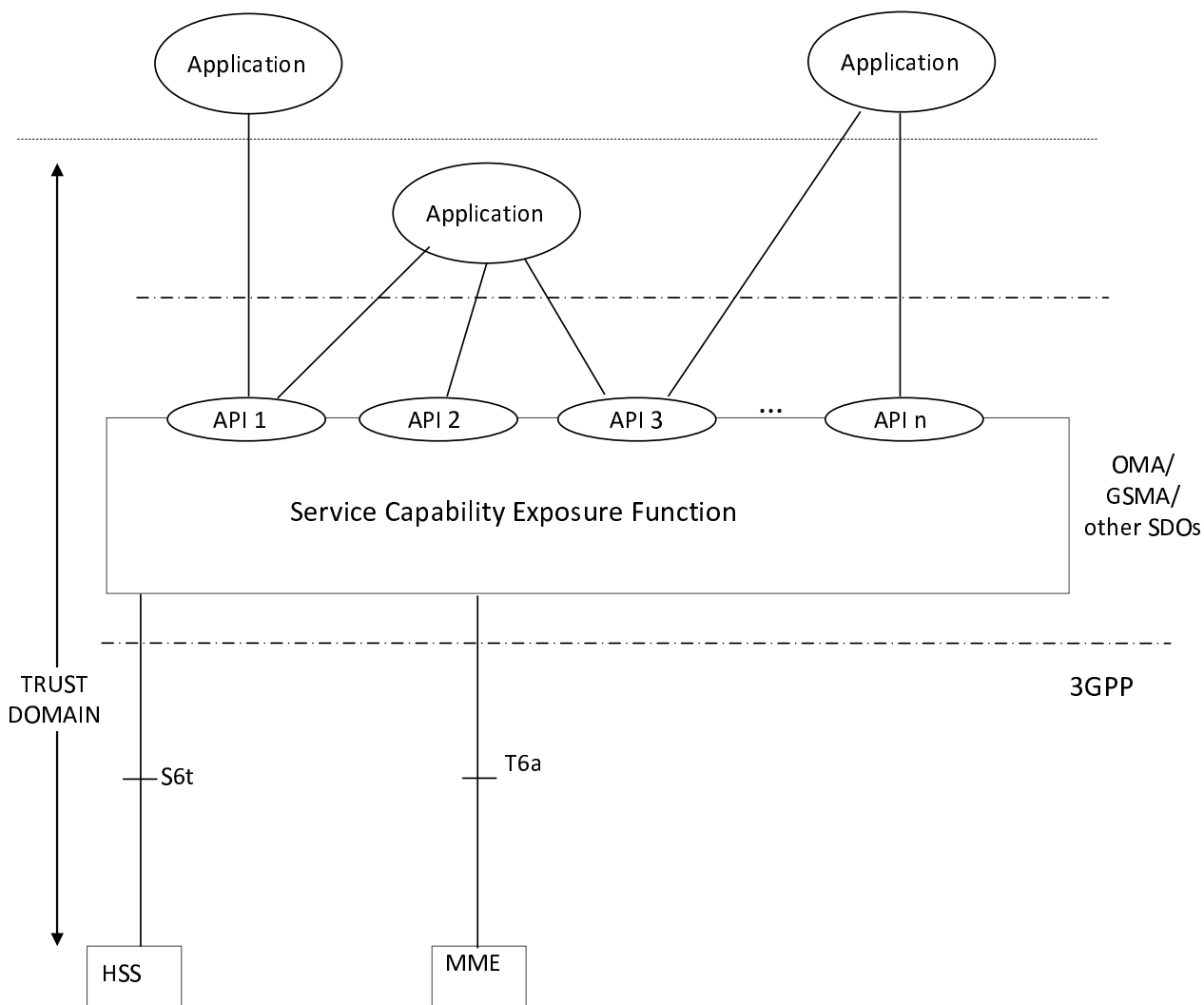

**Figure 4.1.1: 3GPP Architecture Service Capability Exposure for Non-IP Data Delivery**

For roaming case, the Interworking SCEF (IWK-SCEF) is optionally deployed and located in the VPLMN, as described in figure 4.1.2.

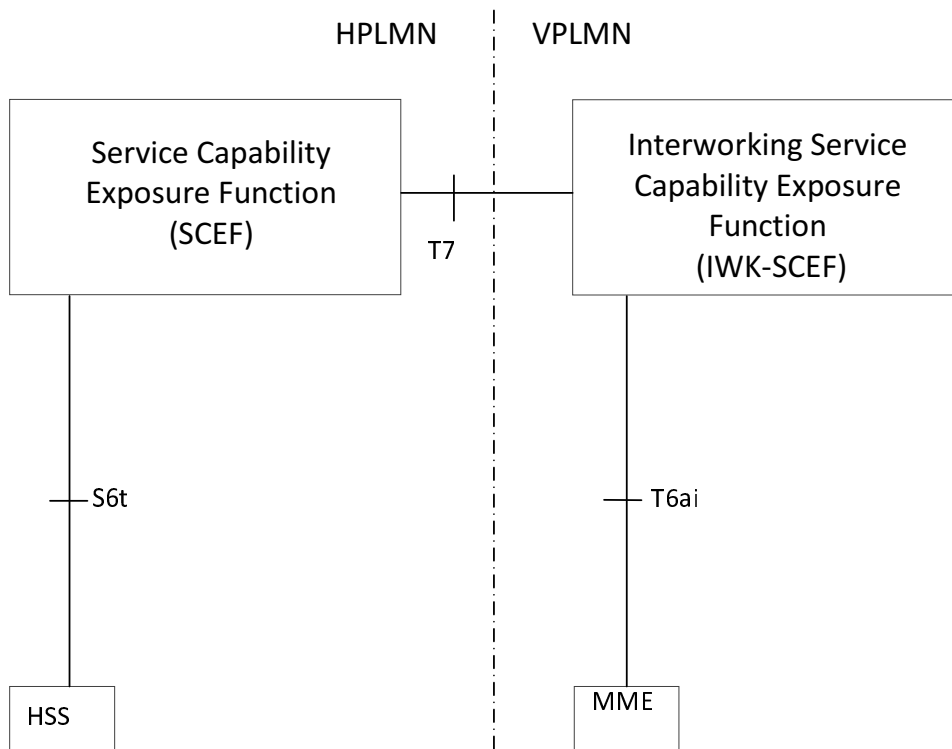

Figure 4.1.2: 3GPP roaming Architecture Service Capability Exposure for Non-IP Data Delivery

## 4.2 CP data transfer domain offline charging architecture

As described in TS 32.240 [1], the CTF (an integrated component in each charging relevant NE) generates charging events and forwards them to the CDF. The CDF, in turn, generates CDRs which are then transferred to the CGF. Finally, the CGF creates CDR files and forwards them to the BD.

For offline charging the following Control Plane data transfer Charging Nodes (CPCN), functioning as the CTF, may generate accounting metrics sets for Control Plane data transfer CDRs:

- the SCEF, to record Control Plane data transfer;
- the IWK-SCEF, to record Control Plane data transfer;
- the MME, to record Control Plane data transfer (optional).

If the CPCN generating the charging information has an integrated CDF, then the CPCN can produce CDRs. The CGF may also be integrated in the CPCN, or it may exist as a physically separate entity.

If the CGF is external to the CPCN/CDF, then the CPCN/CDF forwards the CDRs to the CGF across the Ga interface. In this case, the relationship between CPCN/CDF and CGF is m:1.

If the CGF is integrated in the CPCN/CDF, then there is only an internal interface between the CDF and the CGF. In this case, the relationship between CPCN/CDF and CGF is 1:1. An integrated CGF may support the Ga interface from other CPCN/CDFs.

If the CDF is external to the CPCN, the charging events are transferred from the CPCN to the CDF via the Rf interface specified in TS 32.299 [50]. In this case, the relationship between CPCN and CDF is m:1.

When an external CGF is used, this CGF may also be used by other, i.e. non- Control Plane data transfer, network elements, according to network design and operator decision. It should be noted that the CGF may also be an integrated component of the BD – in this case, the Bcp interface does not exist and is replaced by a proprietary solution internal to the BD.

Figure 4.2.1 depicts the architectural options described above.

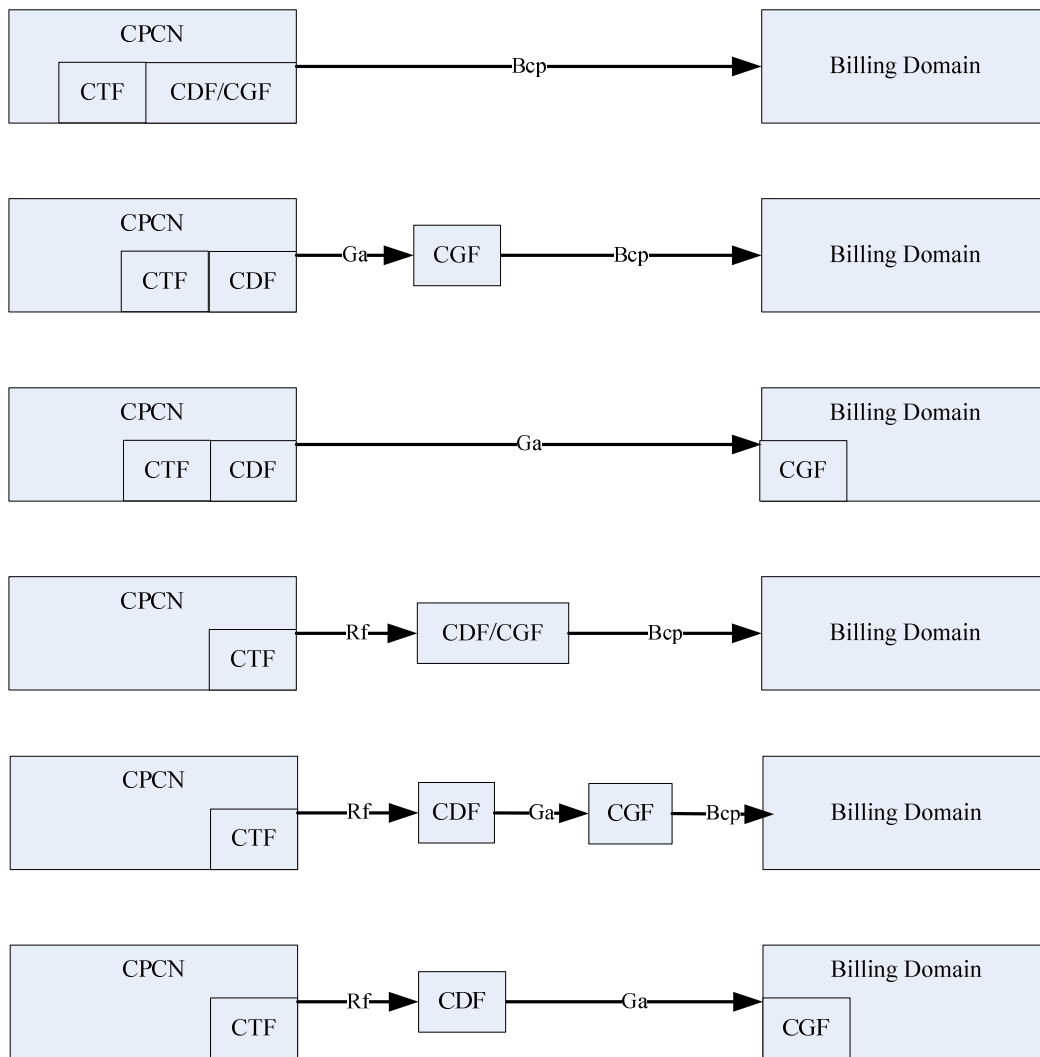

**Figure 4.2.1: Control Plane data transfer offline charging architecture**

It is mandatory to support at least one of the Rf, Ga or Bcp interfaces from the CPCN as described in the present document.

NOTE: Support of Control Plane data transfer charging is optional for the MME.

### 4.3 CP data transfer domain online charging architecture

Not specified in the present document.

## 5 CP data transfer domain charging principles and scenarios

### 5.1 CP data transfer domain charging principles

The following are high level charging requirements for Control Plane data transfer, derived from requirements in TS 23.682 [243]:

- Every PDN connection shall be assigned a unique identity number for billing purposes. (i.e. the Charging Id);
- CPCN shall be capable of identifying NIDD submission request events in mobile originated (MO) and mobile terminated (MT) direction;
- CPCN shall be capable of identifying data volume per NIDD submission request;

- CPCN shall be capable of handling the Charging Characteristics;
- CPCN shall be able, based on operator configuration, to collect charging information for the PDN connection in the same PLMN using offline charging;
- PDN connection in a different PLMN using offline charging.

For the PDN connection, the CPCN shall collect the following information:

- usage of the radio interface: the charging information shall describe the amount of data transmitted in MO and MT directions using Control Plane CIoT EPS Optimisation per each NIDD submission per RAT type and authorized Serving PLMN/APN Rate controls;
- usage duration: duration of PDN connection is counted as the time interval from PDN connection activation to PDN connection deactivation;
- destination and source: the charging information shall provide the user identity (IMSI) and subscriber equipment number (IMEISV) used by the subscriber for the PDN connection and the destination as determined by the Access Point Name (APN) and SCEF address;
- usage of the external data networks: the charging information shall describe the amount of data sent and received to and from the external data network with the corresponding time stamp per each NIDD submission;
- location of MS/UE: HPLMN, VPLMN, plus optional higher-accuracy location information.

## 5.2 CP data transfer domain offline charging scenarios

### 5.2.1 Basic principles

If charging is supported by an CPCN (SCEF, IWK-SCEF, or optionally MME), it shall be able to collect charging information per user per PDN connection, and per Non-IP Data Delivery submission in both originating and terminating directions with associated volume counts.

The user is identified by the IMSI, while the PDN connection to the SCEF can be determined by a unique identifier generated by the SCEF when creating a PDN connection. This identifier is forwarded to the MME so as to allow correlation of MME PDN connection CDRs if any, with the matching SCEF CDRs in the BD. In roaming case, this identifier is forwarded to the IWK-SCEF so as to allow correlation between IWK-SCEF PDN connection CDRs in VPLMN and SCEF PDN connection CDRs in the HPLMN.

The following chargeable events are defined for Control Plane data transfer charging for all CPCNs:

- Start of PDN connection. Upon encountering this event, a CDR for this PDN connection is created;
- End of PDN connection. Upon encountering this event, the CDR is closed;
- NIDD submission request. Upon encountering this event, the NIDD submission with associated volume count is added to the CDR;
- Mobility to a new MME. Upon encountering this event, the CDR is closed. In SCEF and IWK-SCEF, a new one is opened if the PDN connection is still active. In the new MME the CDR is created;
- Serving PLMN Rate Control change. This event closes the CDR, and a new one is opened if the PDN connection is still active.
- APN PLMN Rate Control change in SCEF. This event is applicable for the SCEF only. This event closes the CDR, and a new one is opened if the PDN connection is still active.
- PLMN change. This event closes the CDR. In the SCEF, a new one is opened if the PDN connection is still active;
- Intersystem change (e.g. change of RAT type). This event closes the CDR, and a new one is opened if the PDN connection is still active.

NOTE: Inter-RAT mobility between NB-IoT and other RAT is not supported in this release.

- Expiry of an operator configured time limit per PDN connection. This event closes the CDR, and a new one is opened if the PDN connection is still active;
- Expiry of an operator configured data volume limit per PDN connection. This event closes the CDR, and a new one is opened if the PDN connection is still active;
- Expiry of an operator configured NIDD submissions limit per PDN connection. This event closes the CDR, and a new one is opened if the PDN connection is still active.

Management intervention may also force trigger a chargeable event.

## 5.2.2 Rf message flows

### 5.2.2.1 Triggers for charging events from CPCN

When a charging event is reported to the CDF, it includes details such as user identity, Charging Id, APN, SCEF address, MME address, and in roaming scenario, IWK-SCEF address. NIDD submissions charging information, including associated volume count are reported with corresponding charging events to the CDF.

The Charging Characteristics are also used to set the coherent chargeable event conditions (e.g. time/volume limits that trigger CDR generation or information addition). The Charging Characteristics is provided by the HSS to the CPCNs as part of the subscription information. Further details about Charging Characteristics are defined in Annex A.

When offline charging is activated for CP data transfer in CPCN, it shall be possible to define separate trigger conditions values per Charging Characteristics profile for the following triggers:

- data volume limit;
- time (duration limit);
- maximum number of NIDD submissions.

If, according to the Charging Characteristics profile, offline charging is activated for CP data transfer in CPCN, Charging Data Request [Start] is sent at PDN connection creation.

Charging Data Request [Stop] is sent at PDN connection release.

Charging Data Request [Interim] is sent during the lifetime of the PDN connection, upon occurrence of the trigger conditions specified in Table 5.2.2.1.1.

**Table 5.2.2.1.1: Triggers for Charging Data Request from CPCN**

Message	Trigger Conditions
Charging Data Request [Start]	PDN connection creation
Charging Data Request [Interim]	NIDD submit response receipt to NIDD submit request Serving PLMN Rate Control change RAT type change Expiry of time limit
Charging Data Request [Stop]	PDN connection release

When applicable per Charging Characteristics, "data volume limit" and "maximum number of NIDD submissions" are trigger conditions met upon one particular "NIDD submit response to NIDD submit request". They shall be reported along with the Charging Data Request [Interim] triggered by this "NIDD submit response to NIDD submit request" within Change Condition under PS information of Service Information.

NOTE: Inter-RAT mobility between NB-IoT and other RAT is not supported in this release.

### 5.2.2.2 SCEF specific triggers for charging events

The subclause 5.2.2.1 is applicable for CP data transfer collection of charging information and triggers for SCEF CPCN.

Table 5.2.2.2.1 identifies the additional trigger conditions applicable to SCEF.

**Table 5.2.2.2.1: SCEF specific triggers for Charging Data Request**

Message	Trigger Conditions
Charging Data Request [Interim]	NIDD submission response sending MME Change APN Rate Control change PLMN Change

### 5.2.2.3 IWF-SCEF specific triggers for charging events

The subclause 5.2.2.1 is applicable for CP data transfer collection of charging information and triggers for IWK-SCEF CPCN.

Table 5.2.2.3.1 identifies the additional trigger conditions applicable to IWK-SCEF.

**Table 5.2.2.3.1: IWF-SCEF specific triggers for Charging Data Request**

Message	Trigger Conditions
Charging Data Request [Interim]	NIDD submission response sending Change Serving PLMN Rate Control change
Charging Data Request [Stop]	PLMN Change

### 5.2.2.4 MME specific triggers for charging events

When optional CP data transfer offline charging is supported by the MME, the subclause 5.2.2.1 is applicable for CP data transfer collection of charging information and triggers for MME CPCN.

Table 5.2.2.4.1 identifies the additional trigger conditions applicable to MME.

**Table 5.2.2.4.1: MME specific triggers for Charging Data Request**

Message	Trigger Conditions
Charging Data Request [Start]	MME Change from old MME
Charging Data Request [Interim]	NIDD delivery to the UE NIDD delivery from the UE error
Charging Data Request [Stop]	MME Change to new MME PLMN Change

## 5.2.3 CDR generation

### 5.2.3.1 Introduction

For each of the CPCNs (SCEF, IWK-SCEF and MME), a CP data transfer CDR is generated for subsequent transfer to the Charging Gateway Function (CGF).

The following clauses describe the trigger conditions for these CP data transfer CDRs creation, update and closure.

### 5.2.3.2 Triggers for CPDT-SCE-CDR creation and closure

#### 5.2.3.2.1 General

A CPDT-SCE-CDR is used to collect charging information related to Control Plane data transfer offline charging from a SCEF.

A CPDT-SCE-CDR shall be opened at PDN connection start, and shall be closed as described in subclause 5.2.3.2.3.

Charging information shall be added to a CPDT-SCE-CDR as described in subclause 5.2.3.2.2.

#### 5.2.3.2.2 Triggers for CPDT-SCE-CDR charging information addition

The "List of NIDD submissions" attributes of the CPDT-SCE-CDR consists of a set of containers. Each container identifies a NIDD submission and shall be added to the "List of NIDD submissions" per table 5.2.3.2.2.1 trigger conditions. Details of the container are defined in clause 6.1.3.4.

Table 5.2.3.2.2.1 identifies which conditions are supported to trigger CPDT-SCE-CDR charging information addition.

**Table 5.2.3.2.2.1: Triggers for CPDT-SCE-CDR charging information addition**

Trigger Conditions	Description/Behaviour
NIDD submission response receipt	On receipt of NIDD submit response to NIDD submit request, the NIDD submission container shall be added to the CPDT-SCE-CDR.
NIDD submission response sending	On sending of NIDD submit response to received NIDD submit request, the NIDD submission container shall be added to the CPDT-SCE-CDR.
NIDD submission timeout	On timer expiry due to no NIDD submit response to a NIDD submit request, the NIDD submission container shall be added to the CPDT-SCE-CDR.

### 5.2.3.2.3 Triggers for CPDT-SCE-CDR closure

The CPDT-SCE-CDR shall be closed on encountering any of the following trigger conditions identified in Table 5.2.3.2.3.1:

**Table 5.2.3.2.3.1: Triggers for CPDT-SCE-CDR closure**

Closure Conditions	Description/Behaviour
PDN connection release.	PDN connection release shall result in the CDR being closed. The trigger condition covers: <ul style="list-style-type: none"> <li>- termination of PDN connection;</li> <li>- any abnormal release.</li> </ul>
Partial Record Reason	Partial Record Reason, shall result in the CDR being closed. The trigger condition covers: <ul style="list-style-type: none"> <li>- data volume limit;</li> <li>- time (duration limit);</li> <li>- maximum number of NIDD submissions;</li> <li>- MME change;</li> <li>- Serving PLMN Rate Control change;</li> <li>- APN Rate Control change;</li> <li>- PLMN change;</li> <li>- radio access technology change (RAT Type);</li> <li>- Management intervention.</li> </ul>

The Partial Record generation trigger thresholds are those associated with the Charging Characteristics. The Partial Record generation trigger thresholds are SCEF configuration parameters defined per Charging Characteristics profile by the operator through OAM&P means, as specified in Annex A.

In the event that the CPDT-SCE-CDR is closed and the PDN connection remains active, a further CPDT-SCE-CDR is opened with an incremented Sequence Number.

NOTE: Inter-RAT mobility between NB-IoT and other RAT is not supported in this release.

### 5.2.3.3 Triggers for CPDT-SNN-CDR creation and closure - IWK-SCEF

#### 5.2.3.3.1 General

A CPDT-SNN-CDR is used to collect charging information related to Control Plane data transfer offline charging from a IWK-SCEF.

A CPDT-SNN-CDR shall be opened at PDN connection start for this IWK-SCEF, i.e. upon PDN connection creation and mobility towards the new IWK-SCEF (upon PLMN change).

A CPDT-SNN-CDR shall be closed as described in subclause 5.2.3.3.3.

Charging information shall be added to a CPDT-SNN-CDR as described in subclause 5.2.3.3.2.



### 5.2.3.3.2 Triggers for CPDT-SNN-CDR charging information addition - IWK-SCEF

The "List of NIDD submissions" attributes of the CPDT-SNN-CDR consists of a set of containers. Each container identifies a NIDD submission and shall be added to the "List of NIDD submissions" per table 5.2.3.3.2.1 trigger conditions. Details of the container are defined in clause 6.1.3.4.

Table 5.2.3.3.2.1 identifies which conditions are supported to trigger CPDT-SNN-CDR charging information addition.

**Table 5.2.3.3.2.1: Triggers for CPDT-SNN-CDR charging information addition - IWK-SCEF**

Trigger Conditions	Description/Behaviour
NIDD submission response receipt	On receipt of NIDD submit response to NIDD submit request, the NIDD submission container shall be added to the CPDT-SNN-CDR.
NIDD submission response sending	On sending of NIDD submit response to received NIDD submit request, the NIDD submission container shall be added to the CPDT-SCE-CDR.

### 5.2.3.3.3 Triggers for CPDT-SNN-CDR closure - IWK-SCEF

The CPDT-SNN-CDR shall be closed on encountering any of the following trigger conditions identified in Table 5.2.3.3.3.1:

**Table 5.2.3.3.3.1: Triggers for CPDT-SNN-CDR closure- IWK-SCEF**

Closure Conditions	Description/Behaviour
PDN connection release.	PDN connection release shall result in the CDR being closed. The trigger condition covers: <ul style="list-style-type: none"> <li>- termination of PDN connection;</li> <li>- PLMN Change;</li> <li>- any abnormal release.</li> </ul>
Partial Record Reason	Partial Record Reason, shall result in the CDR being closed. The trigger condition covers: <ul style="list-style-type: none"> <li>- data volume limit;</li> <li>- time (duration limit);</li> <li>- maximum number of NIDD submissions;</li> <li>- MME change;</li> <li>- Serving PLMN Rate Control change;</li> <li>- radio access technology change (RAT Type);</li> <li>- Management intervention.</li> </ul>

The Partial Record generation trigger thresholds are those associated with the Charging Characteristics. The Partial Record generation trigger thresholds are IWK-SCEF configuration parameters defined per Charging Characteristics profile by the operator through OAM&P means, as specified in Annex A.

In the event that the CPDT-SNN-CDR is closed and the PDN connection remains active, a further CPDT-SNN-CDR is opened with an incremented Sequence Number.

NOTE: Inter-RAT mobility between NB-IoT and other RAT is not supported in this release.

### 5.2.3.4 Triggers for CPDT-SNN-CDR creation and closure - MME

#### 5.2.3.4.1 General

When supported, a CPDT-SNN-CDR is used to collect charging information related to Control Plane data transfer offline charging from a MME.

A CPDT-SNN-CDR shall be opened at PDN connection start for this MME, i.e. upon PDN connection creation and Mobility to this new MME.

A CPDT-SNN-CDR shall be closed as described in subclause 5.2.3.4.3.

Charging information shall be added to a CPDT-SNN-CDR as described in subclause 5.2.3.4.2.

#### 5.2.3.4.2 Triggers for CPDT-SNN-CDR charging information addition - MME

The "List of NIDD submissions" attributes of the CPDT-SNN-CDR consists of a set of containers. Each container identifies a NIDD submission and shall be added to the "List of NIDD submissions" per table 5.2.3.4.2.1 trigger conditions. Details of the container are defined in clause 6.1.3.4.

Table 5.2.3.4.2.1 identifies which conditions are supported to trigger CPDT-SNN-CDR charging information addition.

**Table 5.2.3.4.2.1: Triggers for CPDT-SNN-CDR charging information addition - MME**

Trigger Conditions	Description/Behaviour
NIDD submission response receipt	On receipt of NIDD submit response to NIDD submit request, the NIDD submission container shall be added to the CPDT-SNN-CDR.
NIDD delivery to the UE	On NIDD delivery to the UE, the NIDD submission container shall be added to the CPDT-SNN-CDR.
NIDD submission timeout	On timer expiry due to no NIDD submit response to a NIDD submit request, the NIDD submission container shall be added to the CPDT-SCE-CDR.
NIDD delivery from the UE error	Error cases on receipt of NIDD delivery from the UE.

#### 5.2.3.4.3 Triggers for CPDT-SNN-CDR closure - MME

The CPDT-SNN-CDR shall be closed on encountering any of the following trigger conditions identified in Table 5.2.3.4.3.1:

**Table 5.2.3.4.3.1: Triggers for CPDT-SNN-CDR closure -- MME**

Closure Conditions	Description/Behaviour
PDN connection release.	PDN connection release shall result in the CDR being closed. The trigger condition covers: <ul style="list-style-type: none"> <li>- termination of PDN connection;</li> <li>- MME Change;</li> <li>- any abnormal release.</li> </ul>
Partial Record Reason	Partial Record Reason, shall result in the CDR being closed. The trigger condition covers: <ul style="list-style-type: none"> <li>- data volume limit;</li> <li>- time (duration limit);</li> <li>- maximum number of NIDD submissions;</li> <li>- Serving PLMN Rate Control change;</li> <li>- radio access technology change (RAT Type);</li> <li>- Management intervention.</li> </ul>

The Partial Record generation trigger thresholds are those associated with the Charging Characteristics. The Partial Record generation trigger thresholds are MME configuration parameters defined per Charging Characteristics profile by the operator through OAM&P means, as specified in Annex A.

In the event that the CPDT-SNN-CDR is closed and the PDN connection remains active, a further CPDT-SNN-CDR is opened with an incremented Sequence Number.

NOTE: Inter-RAT mobility between NB-IoT and other RAT is not supported in this release.

### 5.2.4 Ga record transfer flows

Details of the Ga protocol application are specified in TS 32.295 [54].

### 5.2.5 Bx CDR file transfer

Details of the Bx protocol application are specified in TS 32.297 [52].

## 5.3 CP data transfer domain online charging scenarios

### 5.3.1 Basic principles

Not specified in the present document.

### 5.3.2 Ro message flows

Not specified in the present document.

---

## 6. Definition of charging information

### 6.1 Data description for CP data transfer offline charging

#### 6.1.1 Rf message contents

##### 6.1.1.1 General

The CP data transfer offline charging uses the Charging Data Transfer messages Charging Data Request and Charging Data Response defined in TS 32.299 [50].

The Charging Data Request can be of type [Start, Interim and Stop], and includes all charging information. The Charging Data Response is an acknowledgement of the Charging Data Request.

Table 6.1.1.1.1 describes the use of these messages for offline charging.

**Table 6.1.1.1.1: Offline charging messages reference table**

Message	Source	Destination
Charging Data Request	CPCN	CDF
Charging Data Response	CDF	CPCN

The following clauses describe the different fields used in the Charging Data messages and the category in the tables is used according to the charging data configuration defined in clause 5.4 of TS 32.240 [1].

##### 6.1.1.2 Charging data request message

Table 6.1.1.2.1 illustrates the basic structure of a Charging Data Request message from the CPCN as used for Control Plane data transfer offline charging.

**Table 6.1.1.2.1: Charging Data Request message contents**

Information Element	Category	Description
Session Identifier	M	Described in TS 32.299 [50]
Originator Host	M	Described in TS 32.299 [50]
Originator Domain	M	Described in TS 32.299 [50]
Destination Domain	M	Described in TS 32.299 [50]
Operation Type	M	Described in TS 32.299 [50]
Operation Number	M	Described in TS 32.299 [50]
Operation Identifier	O <sub>C</sub>	Described in TS 32.299 [50]
User Name	O <sub>C</sub>	Described in TS 32.299 [50]
Destination Host	O <sub>C</sub>	Described in TS 32.299 [50]
Operation Interval	O <sub>C</sub>	Described in TS 32.299 [50]
Origination State	O <sub>C</sub>	Described in TS 32.299 [50]
Origination Timestamp	O <sub>C</sub>	Described in TS 32.299 [50]
Proxy Information	O <sub>C</sub>	Described in TS 32.299 [50]
Route Information	O <sub>C</sub>	Described in TS 32.299 [50]
Operation Token	O <sub>M</sub>	This field identifies the CP data transfer domain service.
Service Information	O <sub>M</sub>	This field holds the Control Plane data transfer specific information described in clause 6.3.

NOTE: Detailed descriptions of the information elements are provided in TS 32.299 [50].

### 6.1.1.3 Charging data response message

Table 6.1.1.3.1 illustrates the basic structure of a Charging Data Response message as used for Control Plane data transfer offline charging.

**Table 6.1.1.3.1: Charging Data Response message contents**

Information Element	Category	Description
Session Identifier	M	Described in TS 32.299 [50]
Operation Result	M	Described in TS 32.299 [50]
Originator Host	M	Described in TS 32.299 [50]
Originator Domain	M	Described in TS 32.299 [50]
Operation Type	M	Described in TS 32.299 [50]
Operation Number	O <sub>C</sub>	Described in TS 32.299 [50]
Operation Identifier	O <sub>C</sub>	Described in TS 32.299 [50]
Operation Interval	O <sub>C</sub>	Described in TS 32.299 [50]
Error Reporting Host	O <sub>C</sub>	Described in TS 32.299 [50]
Origination State	O <sub>C</sub>	Described in TS 32.299 [50]
Origination Timestamp	O <sub>C</sub>	Described in TS 32.299 [50]
Proxy Information	O <sub>C</sub>	Described in TS 32.299 [50]

NOTE: Detailed descriptions of the information elements are provided in TS 32.299 [50].

## 6.1.2 Ga message contents

Refer to clause 5.2.4 for further information.

### 6.1.3 CDR description on the B<sub>CP</sub> interface

#### 6.1.3.1 General

The following standard CDRs content and format are considered:

- CPDT-SCE-CDR generated for Control Plane data transfer from the SCEF;
- CPDT-SNN-CDR generated for Control Plane data transfer from the IWK-SCEF/MME.

For each of the CDR types, a parameter table, which gives a short description of the parameters, is provided. The category in the tables is used according to the charging data configuration defined in clause 5.4 of TS 32.240 [1]. Full definitions of the CDR parameters, sorted by the name in alphabetical order, are provided in TS 32.298 [51]

#### 6.1.3.2 SCEF Control Plane data transfer charging data (CPDT-SCE-CDR)

Control Plane data transfer record shall be produced for each PDN connection to the SCEF. The fields in the record are specified in table 6.1.3.2.1.

**Table 6.1.3.2.1: SCEF Control Plane data transfer charging data (CPDT-SCE-CDR)**

Field	Category	Description
Record Type	M	SCEF Control Plane data transfer record.
Retransmission	O <sub>C</sub>	This parameter, when present, indicates that information from retransmitted Accounting Requests has been used in this CDR.
Served IMSI	C	IMSI of the served party, if available.
Served MSISDN	O <sub>C</sub>	The primary MSISDN of the subscriber, if available.
Served IMEI	O <sub>C</sub>	The IMEI or IMEISV of the ME, if available.
Charging ID	M	Charging identifier used to identify this PDN connection in different records created by CPCNs.
Service Context Id	O <sub>M</sub>	This parameter indicates the CDR is applicable to Control Plane data transfer service.
Node Id	O <sub>M</sub>	Name of the recording entity.
Record Opening Time	M	Time stamp when the CDF opened the record: at PDN connection start or on subsequent partial records.
Duration	M	Duration of this record in the SCEF
Access Point Name Network Identifier	O <sub>M</sub>	The logical name of the connected access point to the external packet data network (network identifier part of APN).
SCEF ID	M	This parameter holds the identity of the SCEF used for this PDN connection.
Charging Characteristics	M	The Charging Characteristics applied to the PDN connection.
Charging Characteristics Selection Mode	O <sub>M</sub>	Holds information about how Charging Characteristics were selected.
RAT Type	O <sub>C</sub>	This field indicates the Radio Access Technology (RAT) type currently used by the Mobile Station as defined in TS 29.061 [207], when available.
Serving Node Identity	M	MME Identity used during this record.
Serving Node PLMN Identifier	O <sub>M</sub>	This fields holds the PLMN Identifier (MCC and MNC) serving the UE during this record.
Serving PLMN Rate Control	O <sub>C</sub>	This field holds the Serving PLMN Rate Control used by the MME during this record
List of NIDD submissions	O <sub>C</sub>	This field holds the list of NIDD submission containers. Each NIDD submission is time stamped, and contains the volume submitted, result of the submission and other information associated to this submission. See table 6.1.3.4.1 for a description of List of NIDD submissions.
External Identifier	O <sub>C</sub>	This field holds the external Identifier identifying the served party associated to the IMSI, if available.
APN Rate Control	O <sub>C</sub>	This field holds the list of APN Rate Controls enforced in the SCEF during this record.
Cause for Record Closing	M	The reason for the release of record from this SCEF.
Diagnostics	O <sub>M</sub>	A more detailed reason for the release of the PDN connection, when a single cause is applicable.
Local Record Sequence Number	O <sub>M</sub>	Consecutive record number created by this node. The number is allocated sequentially including all CDR types.
Record Sequence Number	C	Partial record sequence number, only present in case of partial records.
Record Extensions	O <sub>C</sub>	A set of network operator/manufacture specific extensions to the record. Conditioned upon the existence of an extension.

### 6.1.3.3 Serving Network Control Plane data transfer charging data for IWK-SCEF/MME (CPDT-SNN-CDR)

If enabled, a Control Plane data transfer record shall be produced for each PDN connection to the IWK-SCEF/MME. The fields in the record are specified in table 6.1.3.3.1.

**Table 6.1.3.3.1: Serving Network Control Plane data transfer charging data (CPDT-SNN-CDR)**

Field	Category	Description
Record Type	M	IWK-Serving Network Control Plane data transfer record.
Retransmission	O <sub>C</sub>	This parameter, when present, indicates that information from retransmitted Accounting Requests has been used in this CDR.
Served IMSI	C	IMSI of the served party, if available.
Served MSISDN	O <sub>C</sub>	The primary MSISDN of the subscriber, if available.
Served IMEI	O <sub>C</sub>	The IMEI or IMEISV of the ME, if available.
Charging ID	M	Charging identifier used to identify this PDN connection in different records created by CPCNs.
Service Context Id	O <sub>M</sub>	This parameter indicates the CDR is applicable to Control Plane data transfer service.
Node Id	O <sub>M</sub>	Name of the recording entity.
Record Opening Time	M	Time stamp when the CDF opened the record: at PDN connection start or on subsequent partial records.
Duration	M	Duration of this record in the Serving Network Node.
Access Point Name Network Identifier	O <sub>M</sub>	The logical name of the connected access point to the external packet data network (network identifier part of APN).
SCEF ID	M	This parameter holds the identity of the SCEF used for this PDN connection.
Charging Characteristics	M	The Charging Characteristics applied to the PDN connection.
Charging Characteristics Selection Mode	O <sub>M</sub>	Holds information about how Charging Characteristics were selected.
RAT Type	O <sub>C</sub>	This field indicates the Radio Access Technology (RAT) type currently used by the Mobile Station as defined in TS 29.061 [207], when available.
Serving Node Identity	M	MME Identity used during this record.
Serving Node PLMN Identifier	O <sub>C</sub>	This fields holds the PLMN Identifier (MCC and MNC) serving the UE during this record.
Serving PLMN Rate Control	O <sub>C</sub>	This field holds the Serving PLMN Rate Control used by the MME during this record.
List of NIDD submissions	O <sub>C</sub>	This field holds the list of NIDD submission containers. Each NIDD submission is time stamped, and contains the volume submitted, result of the submission and other information associated to this submission. See table 6.1.3.4.1 for a description of List of NIDD submissions.
Cause for Record Closing	M	The reason for the release of record from this Serving Network Node.
Diagnostics	O <sub>M</sub>	A more detailed reason for the release of the PDN connection, when a single cause is applicable.
Local Record Sequence Number	O <sub>M</sub>	Consecutive record number created by this node. The number is allocated sequentially including all CDR types.
Record Sequence Number	C	Partial record sequence number, only present in case of partial records.
Record Extensions	O <sub>C</sub>	A set of network operator/manufacture specific extensions to the record. Conditioned upon the existence of an extension.

#### 6.1.3.4 NIDD submission

Table 6.1.3.4.1 contains the description fields in the List of NIDD submissions.

**Table 6.1.3.4.1: NIDD submission within List of NIDD submissions**

Field	Category	Description
Submission Timestamp	O <sub>C</sub>	This field holds the time stamp when the data transfer request NIDD submission was submitted to the CPCN node.
Event Timestamp	O <sub>C</sub>	This field holds the time stamp when the event triggered the generation of charging information from the CPCN node, for the NIDD submission.
Data Volume Downlink	O <sub>C</sub>	This field includes the number of octets transmitted during the NIDD submission in downlink direction.
Data Volume Uplink	O <sub>C</sub>	This field includes the number of octets transmitted during the NIDD submission in uplink direction.
Service Change Condition	O <sub>C</sub>	This field holds the specific reason for the NIDD submission container, e.g. NIDD submission response receipt, NIDD submission response sending, NIDD delivery to the UE, NIDD submission timeout, NIDD delivery from the UE error.
Submission Result Code	O <sub>C</sub>	This field includes the result of NIDD submission.

## 6.2 Data description for CP data transfer online charging

### 6.2.1 Ro message contents

Not specified in the present document.

## 6.3 CP data transfer charging specific parameters

### 6.3.1 Definition of CP data transfer charging information

#### 6.3.1.1 CP data transfer charging information assignment for Service Information

The components in the Service Information that are used for CP data transfer charging can be found in table 6.3.1.1.1.

**Table 6.3.1.1.1: Service Information used for CP data transfer charging**

Information Element	Category	Description
Service Information	O <sub>M</sub>	This is a structured field and holds the 3GPP specific parameter as defined in TS 32.299 [50].
Subscriber Identifier	O <sub>M</sub>	This field contains the identification of the user (i.e. IMSI, and MSISDN if any).
IMS Information	O <sub>M</sub>	This is a structured field and holds IMS specific parameters. The complete structure is defined in TS 32.260 [20].
Node Functionality	O <sub>M</sub>	This field contains the function of the CPCN node (i.e. SCEF, IWK-SCEF, MME)
PS Information	O <sub>M</sub>	This is a structured IE and hold PS specification parameters. The complete structure is defined in TS 32.251 [11].
PDN Connection Charging Identifier	O <sub>M</sub>	This parameter holds the Charging Id for this PDN connection (this together with the SCEF ID constitutes a unique identifier for the PDN connection).
Node Id	O <sub>C</sub>	This IE holds the name of the Node.
Called Station Id	O <sub>C</sub>	This parameter contains the identifier of the access point (APN) the user is connected to.
Charging Characteristics	O <sub>C</sub>	The Charging Characteristics applied to this PDN connection in the CPCN.
Charging Characteristics Selection Mode	O <sub>C</sub>	Holds information about how Charging Characteristics were selected.
User Equipment Info	O <sub>C</sub>	This field holds the identification of the terminal (IMEI or IMEISV).
RAT Type	O <sub>C</sub>	This field indicates which Radio Access Technology (RAT) is currently serving the UE as defined in TS 29.061 [207].
Serving Node MCC MNC	O <sub>C</sub>	This field holds the MCC and MNC serving the UE.
Serving PLMN Rate Control	O <sub>C</sub>	This parameter holds the Serving PLMN Rate Control used by MME during this record
APN Rate Control	O <sub>C</sub>	This parameter holds the APN Rate Control enforced in the SCEF during this record.
Change Condition	O <sub>C</sub>	This field holds the reason for sending Charging Data Request from the CPCN.
Diagnostics	O <sub>C</sub>	This parameter holds a more detailed reason for the release of the PDN connection, when a single cause is applicable, and complements the "Change Condition" information.
CPDT Information	O <sub>M</sub>	This is a structured field and holds the CP data transfer specific parameters. The details are defined in clause 6.3.1.2.



### 6.3.1.2 Definition of the CP data transfer Information

CP data transfer specific charging information is provided within the CPDT Information. The fields of the CPDT Information are indicated with the CPCN node (SCEF, IWK-SCEF, MME) from which the information is sent.

The detailed structure of the CPDT Information can be found in table 6.3.1.2.1.

**Table 6.3.1.2.1: Structure of the CPDT Information**

Information Element	Category	Description
External Identifier	O <sub>C</sub>	This parameter holds the external Identifier identifying the served party associated to the IMSI, if available
SCEF ID	O <sub>C</sub>	This parameter holds the identity of the SCEF used for this PDN connection.
Serving Node Identity	O <sub>C</sub>	This parameter holds the MME Identity of the MME serving the UE.
Serving Node Change	O <sub>C</sub>	This parameter is present if this is first Charging Data Request after a change from another MME.
NIDD submission	O <sub>C</sub>	This parameter holds the NIDD submission container associated to trigger conditions met.
Submission Timestamp	O <sub>C</sub>	This parameter holds the time stamp when the data transfer request NIDD submission was submitted to the CPCN Node.
Event Timestamp	O <sub>C</sub>	This parameter holds the time stamp when the event triggered the generation of charging information from the CPCN Node, for the NIDD submission.
Data Volume Uplink	O <sub>C</sub>	This parameter holds the data volume transmitted in uplink direction
Data Volume Downlink	O <sub>C</sub>	This parameter holds the data volume transmitted in downlink direction
Change Condition	O <sub>C</sub>	This parameter holds the specific reason for the NIDD submission container to be added, e.g. NIDD submission response receipt, NIDD submission response sending, NIDD delivery to the UE, NIDD submission timeout, NIDD delivery from the UE error.
Result Code	O <sub>C</sub>	This parameter holds the result of NIDD submission

### 6.3.2 Detailed message format for offline charging

The following clause specifies per Operation Type the charging data that are sent by CPCN for CP data transfer offline charging.

The Operation Types are listed in the following order: S (Start)/I (Interim)/S (Stop)/E (Event). Therefore, when all Operation Types are possible it is marked as SISE. If only some Operation Types are allowed for a node, only the appropriate letters are used (i.e. SIS or E) as indicated in the table heading. The omission of an Operation Type for a particular field is marked with "-" (i.e. SI-E). Also, when an entire field is not allowed in a node the entire cell is marked as "-".

Table 6.3.2.1 illustrates the basic structure of the supported fields in the *Charging Data Request* message for CP data transfer offline charging.

**Table 6.3.2.1: Supported fields in *Charging Data Request* message**

Information Element	Node Type	MME	IWK-SCEF	SCEF
	Supported Operation Types	S/I/S/E	S/I/S/E	S/I/S/E
Session Identifier		SIS-	SIS-	SIS-
Originator Host		SIS-	SIS-	SIS-
Originator Domain		SIS-	SIS-	SIS-
Destination Domain		SIS-	SIS-	SIS-
Operation Type		SIS-	SIS-	SIS-
Operation Number		SIS-	SIS-	SIS-
Operation Identifier		SIS-	SIS-	SIS-
User Name		SIS-	SIS-	SIS-
Destination Host		SIS-	SIS-	SIS-
Operation Interval		SIS-	SIS-	SIS-
Origination State		SIS-	SIS-	SIS-
Origination Timestamp		SIS-	SIS-	SIS-
Proxy Information		SIS-	SIS-	SIS-
Route Information		SIS-	SIS-	SIS-
Operation Token		SIS-	SIS-	SIS-
Subscriber Identifier		SIS-	SIS-	SIS-
Node Functionality		SIS-	SIS-	SIS-
PDN Connection Charging Id		SIS-	SIS-	SIS-
Node Id		SIS-	SIS-	SIS-
Called Station Id		SIS-	SIS-	SIS-
Charging Characteristics		SIS-	SIS-	SIS-
Charging Characteristics Selection Mode		SIS-	SIS-	SIS-
User Equipment Info		SIS-	SIS-	SIS-
RAT Type		SIS-	SIS-	SIS-
Serving Node MCC MNC		SIS-	SIS-	SIS-
Serving PLMN Rate Control		SIS-	SIS-	SIS-
APN Rate Control		-	-	SIS-
Change Condition		SIS-	SIS-	SIS-
Diagnostics		SIS-	SIS-	SIS-
External Identifier		SIS-	SIS-	SIS-
SCEF ID		SIS-	SIS-	SIS-
Serving Node Identity		SIS-	SIS-	SIS-
Serving Node Change		S---	-	-
NIDD submission		SIS-	SIS-	SIS-

### 6.3.3 Detailed message format for online charging

Not specified in the present document.

## 6.4 Bindings for CP data transfer offline charging

This clause aims to describe the mapping between the Diameter Accounting AVP, IEs and CDR parameters for CP data transfer offline charging.

Table 6.4.1 describes the mapping of the Diameter Accounting AVP, IEs and CDR to the CDR parameters of CPCN-SNN-CDR (MME, IWK-SCEF) and CPCN-SCE-CDR.

Table 6.4.1: Bindings of CDR Parameters, Information Elements and AVPs

CDR Parameter	Information Element	AVP
Record Opening Time	-	-
Local Record Sequence Number	-	-
Duration	-	-
Service Context Id	Service Context Id	Service-Context-Id
	<b>Service Information</b>	<b>Service-Information</b>
Served IMSI	Subscriber Identifier	Subscription-Id
Served MSISDN	Subscriber Identifier	Subscription-Id
	<b>IMS Information</b>	<b>IMS-Information</b>
Record Type	Node Functionality	Node-Functionality
	<b>PS Information</b>	<b>PS-Information</b>
Charging ID	Charging Id	3GPP-Charging-Id
Node Id	Node Id	Node-ID
Access Point Name Network Identifier	Called Station Id	Called-Station-Id
Charging Characteristics	Charging Characteristics	3GPP-Charging-Characteristics
Charging Characteristics Selection Mode	Charging Characteristics Selection Mode	Charging-Characteristics-Selection-Mode
Served IMEI	User Equipment Info	User-Equipment-Info
RAT Type	RAT Type	3GPP-RAT-Type
Serving node PLMN Identifier	Serving Node MCC MNC	3GPP-SGSN-MCC-MNC
Serving PLMN Rate Control	Serving PLMN Rate Control	Serving-PLMN-Rate-Control
APN Rate Control	APN Rate Control	APN-Rate-Control
Cause for Record Closing	Change Condition	Change-Condition
Diagnostics	Diagnostics	Diagnostics
	<b>CPDT Information</b>	<b>CPDT-Information</b>
External Identifier	External Identifier	External-Identifier
SCEF ID	SCEF ID	SCEF-ID
Serving Node Identity	Serving Node Identity	Serving-Node-Identity
Serving Node Change	Serving Node Change	SGW-Change
List of NIDD submissions	NIDD submission	NIDD-submission
Submission Timestamp	Submission Timestamp	Submission-Timestamp
Event Timestamp	Event Timestamp	Event-Timestamp
Data Volume Uplink	Data Volume Uplink	Accounting-Output-Octets
Data Volume Downlink	Data Volume Downlink	Accounting-Input-Octets
Service Change Condition	Change Condition	Change-Condition
Submission Result Code	Result Code	Result-Code

---

# Annex A (normative): Charging characteristics

## A.1 General

Charging Characteristics can be supplied by the HSS to the MME as part of the subscription information. Upon PDN connection to the SCEF (decided by the MME for a non-IP PDN connection to an APN associated with an "Invoke SCEF Selection" indicator), the MME forwards the Charging Characteristics parameter to the SCEF, if deployed for roaming to the IWK-SCEF. A subscriber may have Charging Characteristics assigned to his subscription and/or his subscribed APNs. Default charging characteristics may also be pre-provisioned on the CPCN.

Each CPCN may either apply the Charging Characteristics provided by the HSS or ignore it to apply a default configuration. Consequently, the network may apply:

- The Charging Characteristics provided by the HSS
- The Home default behaviour (the MME belongs to the Home PLMN)
- The Roaming default behaviour (the MME belongs to the Visited PLMN)

The Charging Characteristics parameter format is specified TS 32.298 [51]. Each bit of the string of 16 bits corresponds to a specific charging behaviour which is defined on a per operator basis, configured within the CPCN and pointed when bit is set to "1" value.

For example, one way to define a charging behaviour could be to associate it to a specific usage, which may consist of a set of trigger profiles associated to CDR types e.g.:

- **CPDT-SCE-CDR:** activate/deactivate CDRs, time limit, data volume limit, maximum number of NIDD submissions;
- **CPDT-SNN-CDR:** same as CPDT-SCE-CDR.

In addition to these trigger sets, a CDF/CGF address may also be included.

## Annex B (informative): Change history

Change history							
Date	Meeting	TDoc	CR	Rev	Cat	Subject/Comment	New version
2016-06	SA#72					EditHelp cleanup and version under change control	13.0.0
2016-09	SA#73	SP-160621	0001	1	F	Correction of trigger conditions description for NIDD submission	13.1.0
2016-09	SA#73	SP-160621	0002	-	F	Remove Editor's Note on parameters over T6a – Alignment with TS 23.282	13.1.0
2017-03	SA#75	-	-	-	-	Promotion to Release 14 without technical change	14.0.0
2018-06	-	-	-	-	-	Update to Rel-15 version (MCC)	15.0.0

---

# History

<b>Document history</b>		
V15.0.0	July 2018	Publication