

ETSI TS 127 003 V8.0.0 (2009-01)

Technical Specification

**Digital cellular telecommunications system (Phase 2+);
Universal Mobile Telecommunications System (UMTS);
LTE;
Terminal Adaptation Functions (TAF) for services using
Synchronous bearer capabilities
(3GPP TS 27.003 version 8.0.0 Release 8)**



Reference

RTS/TSGC-0327003v800

Keywords

GSM, LTE, UMTS

ETSI

650 Route des Lucioles
F-06921 Sophia Antipolis Cedex - FRANCE

Tel.: +33 4 92 94 42 00 Fax: +33 4 93 65 47 16

Siret N° 348 623 562 00017 - NAF 742 C
Association à but non lucratif enregistrée à la
Sous-Préfecture de Grasse (06) N° 7803/88

Important notice

Individual copies of the present document can be downloaded from:

<http://www.etsi.org>

The present document may be made available in more than one electronic version or in print. In any case of existing or perceived difference in contents between such versions, the reference version is the Portable Document Format (PDF). In case of dispute, the reference shall be the printing on ETSI printers of the PDF version kept on a specific network drive within ETSI Secretariat.

Users of the present document should be aware that the document may be subject to revision or change of status. Information on the current status of this and other ETSI documents is available at

<http://portal.etsi.org/tb/status/status.asp>

If you find errors in the present document, please send your comment to one of the following services:

http://portal.etsi.org/chaicor/ETSI_support.asp

Copyright Notification

No part may be reproduced except as authorized by written permission.
The copyright and the foregoing restriction extend to reproduction in all media.

© European Telecommunications Standards Institute 2009.
All rights reserved.

DECTTM, **PLUGTESTS**TM, **UMTS**TM, **TIPHON**TM, the TIPHON logo and the ETSI logo are Trade Marks of ETSI registered for the benefit of its Members.

3GPPTM is a Trade Mark of ETSI registered for the benefit of its Members and of the 3GPP Organizational Partners.

LTETM is a Trade Mark of ETSI currently being registered

for the benefit of its Members and of the 3GPP Organizational Partners.

GSM[®] and the GSM logo are Trade Marks registered and owned by the GSM Association.

Intellectual Property Rights

IPRs essential or potentially essential to the present document may have been declared to ETSI. The information pertaining to these essential IPRs, if any, is publicly available for **ETSI members and non-members**, and can be found in ETSI SR 000 314: *"Intellectual Property Rights (IPRs); Essential, or potentially Essential, IPRs notified to ETSI in respect of ETSI standards"*, which is available from the ETSI Secretariat. Latest updates are available on the ETSI Web server (<http://webapp.etsi.org/IPR/home.asp>).

Pursuant to the ETSI IPR Policy, no investigation, including IPR searches, has been carried out by ETSI. No guarantee can be given as to the existence of other IPRs not referenced in ETSI SR 000 314 (or the updates on the ETSI Web server) which are, or may be, or may become, essential to the present document.

Foreword

This Technical Specification (TS) has been produced by ETSI 3rd Generation Partnership Project (3GPP).

The present document may refer to technical specifications or reports using their 3GPP identities, UMTS identities or GSM identities. These should be interpreted as being references to the corresponding ETSI deliverables.

The cross reference between GSM, UMTS, 3GPP and ETSI identities can be found under <http://webapp.etsi.org/key/queryform.asp>.

Contents

Intellectual Property Rights	2
Foreword.....	2
Foreword.....	4
1 Scope	5
2 References	5
2.1 Abbreviations	7
2.2 Definitions	7
3 General	7
3.1 Customer access configuration.....	7
3.2 Terminal Adaptation Function	8
3.3 TAF Interfacing to other MT functions	8
4 Terminal Adaptation Functions for synchronous transparent services.....	8
4.1 Rate Adaptation in A/Gb mode	9
4.1.1 Rate adaptation - ITU-T V-series	9
4.1.2 Rate adaptation - ITU-T X.21	9
4.1.3 Rate adaptation - ITU-T S-interface	9
4.2 Interchange Circuit Signalling Mapping	9
4.2.1 ITU-T V-series interchange circuit mapping	9
4.2.1.1 Multislot configurations (Channel coding TCH/F9.6 or TCH/F4.8 kbit/s).....	11
4.2.1.2 Channel coding TCH/F14.4 and TCH/F28.8	12
4.2.2 ITU-T X.21 [23] Interchange circuit mapping.....	12
4.2.3 Case of ITU-T S-interface	12
4.3 Call establishment signalling mapping at TE/MT interface	12
4.3.1 ITU-T V-series interfaces	12
4.3.1.1 Call establishment manual operation - utilizing Alternate Speech/Data or Speech followed by Data Capabilities	12
4.3.1.2 Call establishment manual operation - utilizing the Unrestricted Digital Capability	12
4.3.1.3 ITU-T V.25bis [18] auto call/auto answer	12
4.3.2 ITU-T X-series interfaces	13
4.3.3 ITU-T S-interface (ITU-T I.420 [11]) signalling mapping	13
4.3.4 X.25 Procedures Mapping	13
5 Terminal Adaptation Functions for synchronous non-transparent services.	13
6 V-series interface procedures to 3GPP TS 24.008 [7] mapping.....	14
6.1 Mobile Originated calls	14
6.2 Mobile Terminated calls.....	14
7 ITU-T X.21 [23] interface procedures to 3GPP TS 24.008 [7] mapping.....	15
8 Support for packet service.....	15
Annex A (normative): L2R Functionality	16
Annex B (informative): Change history	17
History	18

Foreword

This Technical Specification (TS) has been produced by the 3rd Generation Partnership Project (3GPP).

The present document defines the interfaces and Terminal Adaptation Functions (TAF) integral to a Mobile Termination (MT) which enables the attachment of synchronous terminals to a MT within the 3GPP system.

The contents of the present document are subject to continuing work within the TSG and may change following formal TSG approval. Should the TSG modify the contents of the present document, it will be re-released by the TSG with an identifying change of release date and an increase in version number as follows:

Version x.y.z

where:

- x the first digit:
 - 1 presented to TSG for information;
 - 2 presented to TSG for approval;
 - 3 or greater indicates TSG approved document under change control.
- y the second digit is incremented for all changes of substance, i.e. technical enhancements, corrections, updates, etc.
- z the third digit is incremented when editorial only changes have been incorporated in the document.

1 Scope

The present document defines Terminal Adaptation Functions (TAF) which are integrated in a Mobile Termination (MT) and which enable the use of synchronous bearer services in the PLMN and the attachment of Synchronous synchronous Terminals terminals to an MT (see 3GPP TS 24.002 [3]). For the case where asynchronous terminals are attached to the TAF when using synchronous bearer services in the PLMN, the reader is referred to 3GPP TS 27.002 [36] for the asynchronous MT-TAF interface specifics and to the present document for synchronous bearer service specifics on the TAF-IWF interface. The general aspects of Terminal Adaptation Functions are contained in specification 3GPP TS 27.001 [9]. The present document covers support of synchronous data services (see 3GPP TS 22.002 [6]) for the following interfaces and procedures:

- V.22 [15] DTE/DCE Interface;
- V.22 bis [16] DTE/DCE Interface;
- V.26 ter [19] DTE/DCE Interface;
- X.21 bis [24] DTE/DCE Interface;
- X.32 [30] Procedure;
- V.25 bis [18] Procedure;

NOTE: From R99 onwards the support of the following services are no longer required by a PLMN:

- the dual Bearer Services "alternate speech/data" and "speech followed by data";
- the dedicated services for PAD and Packet access;
- BS 21 ... 26 and BS 31 ... 34.

From REL-4 onwards the support of the following service is no longer required by a PLMN:

- the synchronous Bearer Service non-transparent (BS 30 NT).

the Teleservice Facsimile non-transparent (TS 61/62 NT) for A/Gb mode.

The support of these services is still optional. The specification of these services is not within the scope of the present document. For that, the reader is referred to GSM R98 or R99 respectively.

NOTE: Please note that the Gb interface does not play any role in the scope of the present document although the term 'A/Gb mode' is used. GERAN Iu mode is for further study.

2 References

The following documents contain provisions which, through reference in this text, constitute provisions of the present document.

- References are either specific (identified by date of publication, edition number, version number, etc.) or non-specific.
- For a specific reference, subsequent revisions do not apply.
- For a non-specific reference, the latest version applies. In the case of a reference to a 3GPP document (including a GSM document), a non-specific reference implicitly refers to the latest version of that document *in the same Release as the present document*.

[1] Void

[2] 3GPP TS 43.010: "GSM Public Land Mobile Network (PLMN) connection types".

- [3] 3GPP TS 24.002: "GSM - UMTS Public Land Mobile Network (PLMN) access reference configuration "
- [4] 3GPP TS 44.021: "Rate adaptation on the Mobile Station - Base Station System (MS - BSS) interface".
- [5] 3GPP TS 08.20: "Rate adaptation on the Base Station System - Mobile-services Switching Centre (BSS - MSC) interface".
- [6] 3GPP TS 22.002: "Circuit Bearer Services (BS) supported by Public Land Mobile Network (PLMN)".
- [7] 3GPP TS 24.008: "Mobile Radio Interface Layer 3 specification; Core Network Protocols-Stage 3".
- [8] Void.
- [9] 3GPP TS 27.001: "General on Terminal Adaptation Functions (TAF) for Mobile Stations (MS)".
- [10] 3GPP TR 21.905: "Vocabulary for 3GPP Specifications "
- [11] ITU-T Recommendation I.420 (1998): "Basic user-network interface".
- [12] Void.
- [13] Void.
- [14] Void.
- [15] ITU-T Recommendation V.22 (1988): "1200 bits per second duplex modem standardized for use in the general switched telephone network and on point-to-point 2-wire leased telephone-type circuits".
- [16] ITU-T Recommendation V.22 bis (1988): "2400 bits per second duplex modem using the frequency division technique standardized for use on the general switched telephone network and on point-to-point 2-wire leased telephone-type circuits".
- [17] ITU-T Recommendation V.24 (1996): "List of definitions for interchange circuits between data terminal equipment (DTE) and data circuit-terminating equipment (DCE)".
- [18] ITU-T Recommendation V.25 bis (1996): "Synchronous and asynchronous automatic dialling procedures on switched networks".
- [19] ITU-T Recommendation V.26 ter (1988): "2400 bits per second duplex modem using the echo cancellation technique standardized for use on the general switched telephone network and on point-to-point 2-wire leased telephone-type circuits".
- [20] ITU-T Recommendation V.28 (1993): "Electrical characteristics for unbalanced double-current interchange circuits".
- [21] Void.
- [22] ITU-T Recommendation V.110 (1996): "Support of data terminal equipments with V-Series interfaces by an integrated services digital network".
- [23] Void.
- [24] Void.
- [25] Void.
- [26] Void.
- [27] Void.
- [28] Void.

- [29] Void.
- [30] ITU-T Recommendation X.32 (1996): "Interface between Data terminal Equipment (DTE) and Data Circuit-terminating Equipment (DCE) for terminals operating in packet mode and accessing a Packet-Switched Public Data Network through a public switched telephone network or an Integrated Services Digital Network or a Circuit-Switched Public Data Network".
- [31] Void.
- [32] Void.
- [33] Personal Computer Memory Card Association: "PCMCIA 2.1 or PC-Card 3.0 electrical specification or later revisions".
- [34] Infrared Data Association IrDA: "IrPHY Physical layer signalling standard".
- [35] Void.
- [36] 3GPP TS 27.002: "Terminal adaptation functions (TAF) for services using asynchronous bearer capabilities".

2.1 Abbreviations

In addition to the abbreviations listed below, the present document also uses terms listed in 3GPP TR 21.905 [10].

IrDA	Infrared Data Association
IrPHY	InfraredPHYSical layer
ITU-T	ITU-Telecommunication Standardization Sector
MUX	Multiplexer

2.2 Definitions

The term 'mobile station' (MS) in the present document is synonymous with the term 'user equipment' (UE) as defined in 3GPP TR 21.905[10].

The term 'TE2' in the present document is synonymous with the term 'TE' as defined in 3GPP TR 21.905[10].

The term 'MT2' in the present document is synonymous with the term 'MT' as defined in 3GPP TR 21.905[10].

For the purposes of the present document the following internal definitions apply in addition to those given in 3GPP TS 21.905[10].

A/Gb mode: indicates that the text applies only to a system or sub-system which operate in A/Gb mode of operation, i.e. with a functional division that is in accordance with the use of an A or a Gb interface between the radio access network and the core network

Iu mode: indicates that the text applies only to a system or a sub-system which operates in Iu mode of operation, i.e. with a functional division that is in accordance with the use of an Iu-CS or Iu-PS interface between the radio access network and the core network

3 General

3.1 Customer access configuration

The PLMN access reference configuration is described in figure 1 of 3GPP TS 24.002 [3] and 3GPP TS 27.001 [9]. The present document specifically refers to the MTs which support terminal equipments (TE1 or TE2) that use synchronous bearer capabilities.

3.2 Terminal Adaptation Function

The TAF is functionally part of an MT0, MT1 or MT2 (see 3GPP TS 24.002 [3]). The terminal adaptation provides facilities to allow manual or automatic call control functions associated with circuit switched data services, in case of ITU-T V series interfaces. The following functions are included:

- conversion of electrical, mechanical, functional and procedural characteristics of the ITU-T V-series, type interfaces to those required by a PLMN;
- bit rate adaptation of ITU-T V-series and ITU-T X-series data signalling rates and the ISDN 64 kbit/s to that provided in an A/Gb mode PLMN;
- the mapping of ITU-T V.25 bis [18] AUTO CALL/AUTO ANSWER procedures to the PLMN Layer 3 signalling;
- the mapping functions necessary to convert ITU-T S-interface signalling to PLMN Layer 3 signalling;
- synchronization procedure, which means the task of synchronizing the entry to and the exit from the data transfer phase between two subscriber terminals. This is described in the specification 3GPP TS 27.001 [9];
- filtering of channel control information. This is described in the specification 3GPP TS 27.001 [9];
- compatibility checking (see 3GPP TS 27.001 [9]);
- flow control;
- in Call Modification function (see clause 4);
- splitting and combining of the data flow in case of multi substream data configurations.

3.3 TAF Interfacing to other MT functions

TAF interfacing is shown in figure 1.

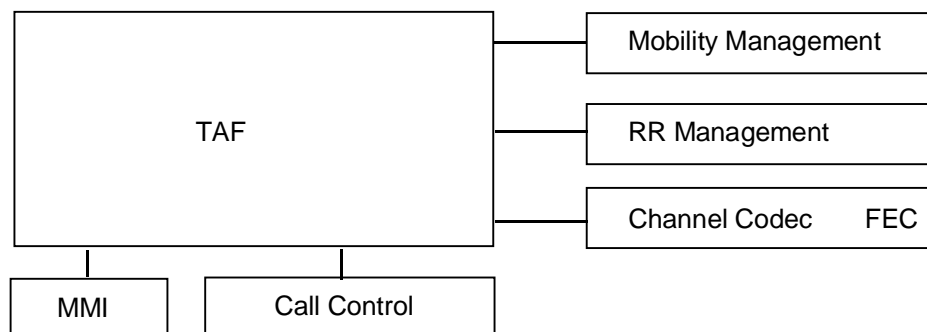

Figure 1: TAF interfacing to other MT functions

4 Terminal Adaptation Functions for synchronous transparent services

Specification 3GPP TS 43.010 [2] refers to the models for connection types supporting synchronous transparent services.

4.1 Rate Adaptation in A/Gb mode

Rate adaptation on the MS-BS interface is described in 3GPP TS 44.021[4]. The synchronous data services make use of the following rate adaptation functions: RA1, RA2, RA1/RA1', RA1' and in case of TCH/F28.8 usage, EDGE-MUX. See also figures 6, 7 and 8 in 3GPP TS 43.010 [2]. The D-bits of the rate adaptation frames are used to convey user data. The S- and X-bits are used to convey channel status information associated with the data bits in the data transfer state, or to carry substream numbering between the Split/Combine functions in case of mult substream operation. For the S- and X-bits, a ZERO corresponds to the ON condition, a ONE to the OFF condition.

4.1.1 Rate adaptation - ITU-T V-series

This is provided as indicated in specification 3GPP TS 44.021 [4]. The functions applied in this case are shown in figure 2 (see model 2b in figures 6, 7 and 8 of 3GPP TS 43.010 [2]).

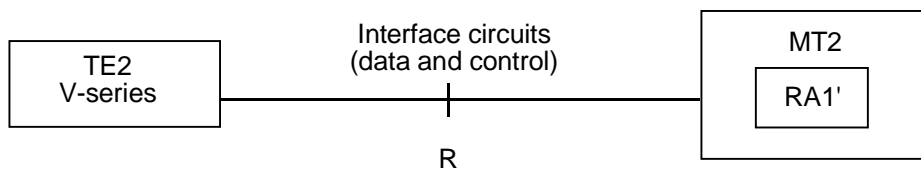

Figure 2: Rate adaptation for V-series terminals

4.1.2 Rate adaptation - ITU-T X.21

Void.

4.1.3 Rate adaptation - ITU-T S-interface

Void.

4.2 Interchange Circuit Signalling Mapping

4.2.1 ITU-T V-series interchange circuit mapping

The interchange circuit signalling mapping at the interface between the TE2 and the MT shall conform to ITU-T recommendation V.24 [17]. The signal levels at the interface shall conform either to ITU-T recommendation V.28 [20], or to IrDA IrPHY Physical signalling standard specification [34], or to PCMCIA 2.1 [33], or to PC-Card 3.0 [33] electrical specifications or to later revisions.

The signals required at this interface are shown in table 2.

- Specification 3GPP TS 44.021 [4] refers to the frame structure and identifies the use of status bits for the carriage of signalling information.

Status bits SA, SB and X are used to convey channel control information associated with the data bits in the data transfer state. Table 1 shows the mapping scheme between the ITU-T V.24 [17] circuit numbers and the status bits for the transparent mode. It also shows how the unused status bits should be handled. It is derived from the general mapping scheme described in annex C. A binary 0 corresponds to the ON condition, a binary 1 to the OFF condition.

The transport of these status bits by the various channel codings is described in subsequent sections.

Table 1: Mapping scheme at the MT for the transparent mode

Signal at TE2/MT interface or condition within the MT	Mapping direction: MT to IWF	Mapping direction: IWF to MT
CT 105	not mapped (note 1)	
CT 106		from status bit X (note 7)
CT 107		not mapped (note 5)
CT 108/2	not mapped (note 6)	
CT 109		from status bit SB (note 7)
CT 133	not mapped (note 2)	
always ON	to status bit SA (note 3)	
always ON	to status bit SB (note 1)	
always ON	to status bit X (note 4)	
ignored by MT		from status bit SA (note 3)
<p>NOTE 1: The SB bit towards the IWF, according to the General Mapping (3GPP TS 27.002, annex C), could be used to carry CT 105. However, CT 105 should always be ON in the data transfer state since only duplex operation is supported. Also, many DTEs use the connector pin assigned to CT 105 for CT 133. No interchange circuit shall be mapped to the SB bit which shall always be set to ON in the data transfer state.</p> <p>NOTE 2: CT 133 is not mapped since there is no flow control in transparent mode.</p> <p>NOTE 3: The SA bits in both directions are available only with certain channel codings. Therefore, for maximum compatibility, they should not be mapped.</p> <p>NOTE 4: The X bit towards the IWF is not mapped and shall always be set to ON in the data transfer state since there is no flow control in transparent mode.</p> <p>NOTE 5: CT 107 is controlled by the channel synchronization process (3GPP TS 27.001 [9]).</p> <p>NOTE 6: CT 108/2 may be used in the call setup and answering processes.</p> <p>NOTE 7: The status bits are filtered before being mapped to the ITU-T V.24 [17] circuits (3GPP TS 27.001 [9]).</p>		

Table 2: Minimum set of V-series interchange circuits

Circuit Number	Circuit Name	Ground	Data		Control	
			to TE2	from TE2	to TE2	from TE2
CT102	Common Return	X				
CT103	Transmitted data			X		
CT104	Received data		X			
CT105	Request to send					X
CT106	Ready for sending				X	
CT107	Data set ready				X	
CT108.2	Data terminal ready					X
CT109	Data channel received line signal detector				X	
CT114	Transmitter signal element timing				X	
CT115	Receiver signal element timing				X	
CT125	Calling indicator (note)				X	
NOTE: CT125 is used with the AUTO ANSWER function of the TAF.						

Use of Network Independent Clocking (applicable to A/Gb mode PLMN only):

Network Independent Clocking is only applicable to calls using ITC value "3.1 kHz audio ex PLMN".

Within the **A/Gb mode PLMN** the coding of the values for bits associated with NIC is specified in 3GPP TS 44.021 [4] and 3GPP TS 08.20 [5]. In the forward (transmitting) direction the multiframes shall be coded in exact accordance with that specified in those specifications. Bit E6 is set to "1" in alternate modified ITU-T V.110 [22] frames at the transmitter. However, the use of this bit at the receiver for monitoring frame Synchronization, or any other purpose, is not specified and is left to the discretion of the implementor.

A "perfect linear block Code" is used in C1-C5, whose error correction properties may be utilized in the receiver, in order to ensure reliable operation of NIC.

The NIC sending function has to recognize when the difference between the applicable clock speed of the **A/Gb mode PLMN** and the interface speed generates a positive or negative whole bit requirement. When this positive or negative condition occurs, the NIC codewords specified in specification 3GPP TS 44.021 [4] are used to transport this condition to the receiving NIC function. Transmission of the codeword shall clear the positive or negative condition related to that codeword at the sending function. The sending function shall not send more than one positive or negative compensation within a contiguous period of time corresponding to 10 000 user data bits minus the number of user data bits necessary to make up an even number of ITU-T V.110 [22] frames. Between compensations (NIC compensation is coded in two ITU-T V.110 [22] frames). This results from the requirements to compensate for maximum clock differences of ± 100 parts per million. If the receiving function receives NIC compensations more often than a contiguous period of time corresponding to 10 000 user data bits, there is no guarantee that data will not be lost.

The NIC receiving function has to provide the capability to support the compensation requirements of the sending function. This compensation is managed by manipulating the clock speed of the interface, within the standard constraints of that interface.

Overall, the compensation functions have to be capable of managing clock tolerances of ± 100 parts per million.

The NIC function has to recognize and manage the conversion of the NIC information received incoming from an ISDN terminal Interface. The conversion has to be made to the NIC format used within the **A/Gb mode PLMN** System as defined in specifications 3GPP TS 44.021 [4] and 3GPP TS 08.20 [5]). The NIC function has to manage the conversion of the PLMN NIC format into that used within the ISDN in the traffic direction towards the ISDN terminal interface.

Due to the incompatibility between the ISDN and the **A/Gb mode PLMN** requirements NIC interworking is not provided between these two formats. as such no NIC function is required in providing interworking to the ISDN for unrestricted digital.

Action on loss of synchronization:

If five consecutive NIC multiframes have incorrect framing bit values in E7, the receiver shall stop applying clocking compensation to the received data. Resynchronization shall be attempted and compensation shall resume when synchronization is achieved.

Signal element timing:

Receiver signal element timing (CT115) is generated by MT2. In the **A/Gb mode PLMN** transparent case, this shall be synchronized to the output of RA1' function. In the UTRAN Iu mode transparent case, this shall be synchronized to output of the RLC. A transition from ON to OFF condition shall nominally indicate the centre of each signal element on CT104.

Transmitter signal element timing is generated by MT2 (CT114), this may be synchronized to CT115.

In the case of alternate Speech/Group 3 Facsimile, there may be a Channel Mode Modify during the course of the facsimile portion of the call. If this occurs, the user data rate changes and this is reflected to the ITU-T V.24 [17] interface as a change in the clock speed on CT 114 and CT 115.

4.2.1.1 Multislot configurations (Channel coding TCH/F9.6 or TCH/F4.8 kbit/s)

In transparent multislot configurations status bits S1, S3 and the X-bit between the D12 and D13 in the ITU-T V.110 [22] 80-bit intermediate rate frame - are used for transferring substream numbering information. The S4-bit is used for frame synchronization between the parallel substreams (ref 3GPP TS 44.021[4]).

4.2.1.2 Channel coding TCH/F14.4 and TCH/F28.8

For information on the mapping of the interchange circuit signalling bits in the 14,5 multiframe structure, refer to 3GPP TS 44.021 [4].

4.2.2 ITU-T X.21 [23] Interchange circuit mapping

Void.

4.2.3 Case of ITU-T S-interface

Void.

4.3 Call establishment signalling mapping at TE/MT interface

4.3.1 ITU-T V-series interfaces

4.3.1.1 Call establishment manual operation - utilizing Alternate Speech/Data or Speech followed by Data Capabilities

Void.

4.3.1.2 Call establishment manual operation - utilizing the Unrestricted Digital Capability

In this case the user shall not hear network supervisory tones or answer tone. The data transfer phase shall be entered automatically.

4.3.1.3 ITU-T V.25bis [18] auto call/auto answer

The mapping of the ITU-T V.25bis [18] procedures to the messages of the PLMN Layer 3 signalling (3GPP TS 24.008 [7]) is defined in clause 4.

Auto Call:

This procedure is provided according to ITU-T V.25bis [18] using only circuit 108/2. A subset of ITU-T V.25bis [18] is shown in table 4. This subset gives minimum level of control and indication.

During the call establishment phase, i.e. after signalling, call tone according to ITU-T V.25 bis [18] shall be generated in the IWF, where appropriate.

Auto Answer:

This procedure is provided according to ITU-T V.25bis [18].

Table 4: Minimum set of ITU-T V.25bis [18] Call Set-up Commands and Indications

	Description	IA5Characters
Commands from TE2	<u>C</u> all <u>R</u> equest with <u>N</u> umber provided 0,1..9,*,#,A,B,C,D <u>D</u> isregard <u>I</u> ncoming <u>C</u> all <u>C</u> onnect <u>I</u> ncoming <u>C</u> all	CRN DIC CIC
Indications to TE2	<u>C</u> all <u>F</u> ailure <u>I</u> ndication XX = CB,AB,NT,FC (Note) <u>I</u> ncoming <u>C</u> all <u>V</u> ALid <u>I</u> NValid	CFI XX INC VAL INV

NOTE to table 4: CB = Local MT busy
 AB = Abort call
 NT = No answer
 FC = Forbidden call (*)

(*) Forbidden call indication results from contravention of rules for repeat call attempts as defined by the appropriate national approval administration. It is recommended that this is the responsibility of the MT, not the TE2.

4.3.2 ITU-T X-series interfaces

Void.

4.3.3 ITU-T S-interface (ITU-T I.420 [11]) signalling mapping

Void.

4.3.4 X.25 Procedures Mapping

Void.

5 Terminal Adaptation Functions for synchronous non-transparent services.

Void.

6 V-series interface procedures to 3GPP TS 24.008 [7] mapping

Interface procedures not directly mappable to 3GPP TS 24.008 [7] (ie. ITU-T V.25 bis [18] VAL/INV) are not considered. Mobile management procedures of 3GPP TS 24.008 [7] are not considered applicable.

Mapping of other call establishment or clearing messages to the S interface e.g. "Call proceeding", etc. have not been included. It is assumed that these may be mapped directly and thus are of no relevance to the ITU-T V.25 bis [18] or manual interface.

6.1 Mobile Originated calls

a) SET-UP.

Element	Derived from	
	MMI	ITU-T V.25 bis [18] message
Called Address	Keypad	CRN/CRI/CRS
Called Sub Address	Keypad	CRI
HLC	Derived from internal settings or MMI information.	
LLC	Same as HLC	
BC	Same as HSC 3GPP TS 27.001 [9] gives allowed values	

b) RELEASE COMPLETE.

Element	Derived from	
	MMI	ITU-T V.25 bis [18] message
Cause	Display (optional)	CFI

6.2 Mobile Terminated calls

Call establishment is initiated by receipt of Setup at the MS:

a) SET-UP.

Element	Mapped on to	
	MMI	ITU-T V.25 bis [18] message
Called Address	Display (optional)	INC
Called Sub Address	Display (optional)	Not applicable
HLC	Display (optional)	Not applicable
LLC	Display (optional)	Not applicable
BC	Display (optional)	Not applicable

b) CALL CONFIRM.

Information for the BC element in the call confirm is derived from e.g. MMI or by internal settings.

c) CONNECT.

Connect is sent in response, CIC from ITU-T V.25 bis [18] or in response from MMI.

7 ITU-T X.21 [23] interface procedures to 3GPP
TS 24.008 [7] mapping

Void.

8 Support for packet service

Void.

Annex A (normative): L2R Functionality

Void

Annex B (informative): Change history

Change history							
Date	TSG #	TSG Doc.	CR	Rev	Subject/Comment	Old	New
04-1999					Transferred to 3GPP CN1	6.0.0	
	CN#03				Approved at CN#03		3.0.0
	CN#04		001		Introduction of EDGE	3.0.0	3.1.0
	CN#06		002		Introduction of Asynchronous interface for Real-time non-transparent FAX	3.1.0	3.2.0
	CN#06		003		R99 service clean-up (also subclause 8.3 removed)	3.1.0	3.2.0
	CN#07		004		UMTS clean up	3.2.0	3.3.0
	CN#08		005		Adaptations for UMTS	3.3.0	3.4.0
	CN#09		006		Modification from V.25bis to V.250	3.4.0	3.5.0
	CN#10		007		Removal of BS 30 NT	3.5.0	4.0.0
03-2001	TSG#11	NP-010046	008		Removal of Fax NT in GSM from Rel-4	4.0.0	4.1.0
12-2001	TSG#14	NP-010604	009		Terminology clarifications as requested by TSG GERAN	4.1.0	5.0.0
12-2004	CN#26				Upgraded to v6.0.0	5.0.0	6.0.0
06-2007	CT#36				Upgraded to v7.0.0	6.0.0	7.0.0
12-2008	CT#42				Upgraded to v8.0.0 due to simple upgrade without no technical change	7.0.0	8.0.0

History

Document history		
V8.0.0	January 2009	Publication