

ETSI TS 126 449 V14.0.0 (2017-04)



**Universal Mobile Telecommunications System (UMTS);
LTE;
Codec for Enhanced Voice Services (EVS);
Comfort Noise Generation (CNG) aspects
(3GPP TS 26.449 version 14.0.0 Release 14)**



Reference

RTS/TSGS-0426449ve00

Keywords

LTE,UMTS

ETSI

650 Route des Lucioles
F-06921 Sophia Antipolis Cedex - FRANCE

Tel.: +33 4 92 94 42 00 Fax: +33 4 93 65 47 16

Siret N° 348 623 562 00017 - NAF 742 C
Association à but non lucratif enregistrée à la
Sous-Préfecture de Grasse (06) N° 7803/88

Important notice

The present document can be downloaded from:
<http://www.etsi.org/standards-search>

The present document may be made available in electronic versions and/or in print. The content of any electronic and/or print versions of the present document shall not be modified without the prior written authorization of ETSI. In case of any existing or perceived difference in contents between such versions and/or in print, the only prevailing document is the print of the Portable Document Format (PDF) version kept on a specific network drive within ETSI Secretariat.

Users of the present document should be aware that the document may be subject to revision or change of status. Information on the current status of this and other ETSI documents is available at
<https://portal.etsi.org/TB/ETSIDeliverableStatus.aspx>

If you find errors in the present document, please send your comment to one of the following services:
<https://portal.etsi.org/People/CommiteeSupportStaff.aspx>

Copyright Notification

No part may be reproduced or utilized in any form or by any means, electronic or mechanical, including photocopying and microfilm except as authorized by written permission of ETSI.

The content of the PDF version shall not be modified without the written authorization of ETSI.
The copyright and the foregoing restriction extend to reproduction in all media.

© European Telecommunications Standards Institute 2017.
All rights reserved.

DECT™, **PLUGTESTS™**, **UMTS™** and the ETSI logo are Trade Marks of ETSI registered for the benefit of its Members.
3GPP™ and **LTE™** are Trade Marks of ETSI registered for the benefit of its Members and of the 3GPP Organizational Partners.
GSM® and the GSM logo are Trade Marks registered and owned by the GSM Association.

Intellectual Property Rights

IPRs essential or potentially essential to the present document may have been declared to ETSI. The information pertaining to these essential IPRs, if any, is publicly available for **ETSI members and non-members**, and can be found in ETSI SR 000 314: "*Intellectual Property Rights (IPRs); Essential, or potentially Essential, IPRs notified to ETSI in respect of ETSI standards*", which is available from the ETSI Secretariat. Latest updates are available on the ETSI Web server (<https://ipr.etsi.org>).

Pursuant to the ETSI IPR Policy, no investigation, including IPR searches, has been carried out by ETSI. No guarantee can be given as to the existence of other IPRs not referenced in ETSI SR 000 314 (or the updates on the ETSI Web server) which are, or may be, or may become, essential to the present document.

Foreword

This Technical Specification (TS) has been produced by ETSI 3rd Generation Partnership Project (3GPP).

The present document may refer to technical specifications or reports using their 3GPP identities, UMTS identities or GSM identities. These should be interpreted as being references to the corresponding ETSI deliverables.

The cross reference between GSM, UMTS, 3GPP and ETSI identities can be found under <http://webapp.etsi.org/key/queryform.asp>.

Modal verbs terminology

In the present document "**shall**", "**shall not**", "**should**", "**should not**", "**may**", "**need not**", "**will**", "**will not**", "**can**" and "**cannot**" are to be interpreted as described in clause 3.2 of the [ETSI Drafting Rules](#) (Verbal forms for the expression of provisions).

"**must**" and "**must not**" are **NOT** allowed in ETSI deliverables except when used in direct citation.

Contents

Intellectual Property Rights	2
Foreword.....	2
Modal verbs terminology.....	2
Foreword.....	4
1 Scope	5
2 References	5
3 Abbreviations	5
4 General	5
5 Functions on the transmit (TX) side.....	6
5.1 EVS primary CNG operation	6
5.2 EVS AMR-WB IO CNG operation	6
6 Functions on the receive (RX) side	7
6.1 EVS primary CNG operation	7
6.2 EVS AMR-WB IO CNG operation	7
7 Computational details and bit allocation	7
Annex A (informative): Change history	8
History	9

Foreword

This Technical Specification has been produced by the 3rd Generation Partnership Project (3GPP).

The contents of the present document are subject to continuing work within the TSG and may change following formal TSG approval. Should the TSG modify the contents of the present document, it will be re-released by the TSG with an identifying change of release date and an increase in version number as follows:

Version x.y.z

where:

- x the first digit:
 - 1 presented to TSG for information;
 - 2 presented to TSG for approval;
 - 3 or greater indicates TSG approved document under change control.
- y the second digit is incremented for all changes of substance, i.e. technical enhancements, corrections, updates, etc.
- z the third digit is incremented when editorial only changes have been incorporated in the document.

1 Scope

The present document gives an overview for the requirements of the background acoustic noise evaluation, noise parameter encoding/decoding and comfort noise generation for the Enhanced Voice Services (EVS) speech codec during Discontinuous Transmission (DTX) operation.

2 References

The following documents contain provisions which, through reference in this text, constitute provisions of the present document.

- References are either specific (identified by date of publication, edition number, version number, etc.) or non-specific.
- For a specific reference, subsequent revisions do not apply.
- For a non-specific reference, the latest version applies. In the case of a reference to a 3GPP document (including a GSM document), a non-specific reference implicitly refers to the latest version of that document *in the same Release as the present document*.

- [1] 3GPP TR 21.905: "Vocabulary for 3GPP Specifications".
 - [2] 3GPP TS 26.445: "Codec for Enhanced Voice Services (EVS); Codec Detailed Algorithmic Description".
 - [3] 3GPP TS 26.442: "Codec for Enhanced Voice Services (EVS); EVS Codec ANSI C code (fixed-point)".
 - [4] 3GPP TS 26.443: "Codec for Enhanced Voice Services (EVS); EVS Codec ANSI C code (floating-point)".
-

3 Abbreviations

For the purposes of the present document, the abbreviations given in TR 21.905 [1] and the following apply. An abbreviation defined in the present document takes precedence over the definition of the same abbreviation, if any, in TR 21.905 [1].

CNG	Comfort Noise Generation
EVS	Enhanced Voice Services
FD-CNG	Frequency Domain based CNG
LP-CNG	Linear Prediction based CNG
SID	Silence Insertion Descriptor

4 General

The present document gives an overview for the requirements of the background acoustic noise evaluation, noise parameter encoding/decoding and comfort noise generation for the Enhanced Voice Services (EVS) speech codec during Discontinuous Transmission (DTX) operation.

The present document is mandatory for implementation in all network entities and UEs supporting the EVS codec.

In the case of discrepancy between the EVS comfort noise aspects described in the present document and its ANSI-C code specification contained in [3], the procedure defined by [3] prevails. In the case of discrepancy between the procedure described in the present document and its ANSI-C code specification contained in [4], the procedure defined by [4] prevails.

A basic problem when using DTX is that the background acoustic noise, which is transmitted together with the speech, would disappear when the transmission is cut, resulting in discontinuities of the background noise. Since the DTX

switching can take place rapidly, it has been found that this effect can be very annoying for the listener - especially in a car environment with high background noise levels. In bad cases, the speech may be hardly intelligible.

The present document specifies the way to overcome this problem by generating on the receive (RX) side synthetic noise similar to the transmit (TX) side background noise. The comfort noise parameters are estimated on the TX side and transmitted to the RX side at a regular rate when speech is not present. This allows the comfort noise to adapt to the changes of the noise on the TX side.

The Enhanced Voice Services (EVS) speech codec supports two Comfort Noise Generation (CNG) schemes, a linear prediction based CNG (LP-CNG) as well as a frequency domain based scheme (FD-CNG). The selection of the one of the two schemes is performed within the transmit side functions on an input signal bases. The parameters for generating the comfort noise are packed as a Silence Insertion Descriptor (SID) payload.

The update rate of the SID payload can be configured to a fixed number or to a mode where the update rate is adaptively modified according to the background noise. The fixed rate mode is limited to updates between 1 and 100 frames while in the adaptive rate mode the updates are limited to 8 and 50 depending on the noise behaviour.

As the functions of the CNG processing are highly integrated into the speech codec and make use of other coding parameters, The present document only provides an overview of the functions. The relevant references to the algorithmic descriptions are provided in the following.

5 Functions on the transmit (TX) side

5.1 EVS primary CNG operation

The CNG operation on the transmit side is described in figure 1. In DTX operation, the SID updater decides if any SID update is required. If the SID payload should be updated, the CNG Selector enables either the LP or the FD CNG encoder depending on the signal characteristic of the background noise. The selected CNG encoder calculates the noise generation parameter and creates the related SID payload.

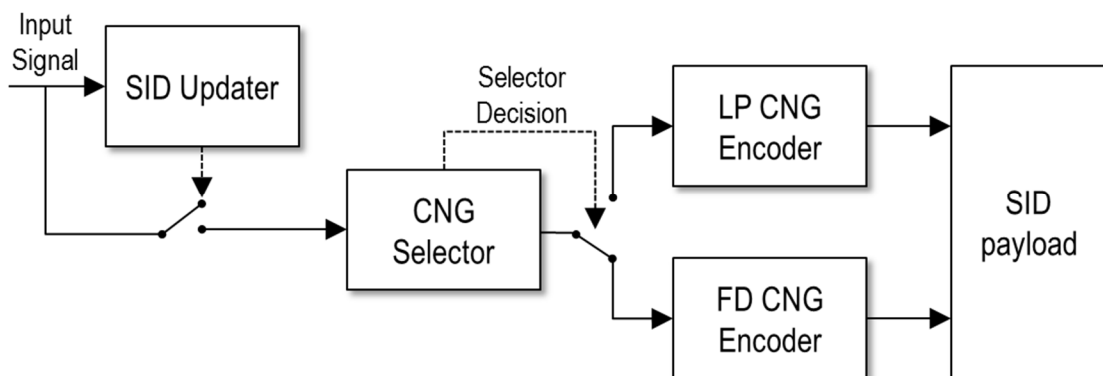

Figure 1: Transmit side Comfort Noise Generator functions

In [2], all TX functions are described in clause 5.6. The algorithmic description of the

- SID Update mechanism can be found in sub-clause 5.6.1.1 and 5.6.1.2
- CNG Selector can be found in sub-clause 5.6.1.3
- LP-CNG encoder in sub-clause 5.6.2
- FD-CNG encoder in sub-clause 5.6.3.

5.2 EVS AMR-WB IO CNG operation

The update rate is basically fixed to an update every 8th frame. However, when switching into DTX mode, the first and the third frame after active speech are coded by a SID frame.

The CNG in the EVS AMR-WB interoperable modes is based the LP-CNG coding scheme only. The complete CNG TX description of the EVS AMR-WB IO mode can be found in [2], clause 5.7.12.

6 Functions on the receive (RX) side

6.1 EVS primary CNG operation

The CNG operation on the receiver side is depicted in Figure 2. The first bit of the SID payload determines the CNG module. The remaining bits contain the information of the noise generator parameters to render the signal.

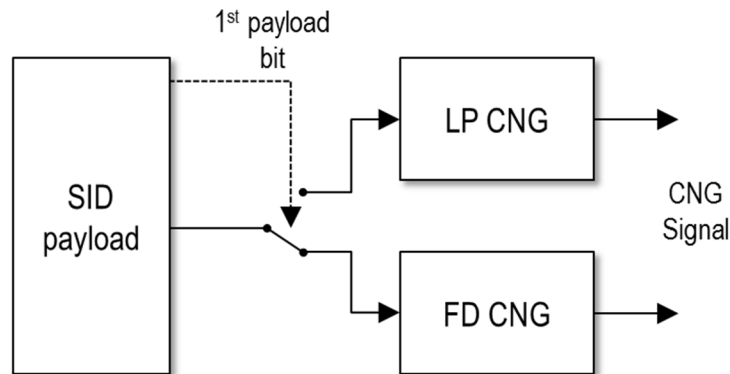

Figure 2: Receive side Comfort Noise Generator functions

The RX CNG operation is described in clause 6.7. The synthesis of the LP-CNG is described in sub-clause 6.7.2 and the synthesis of FD-CNG is described in clause 6.7.3 in [2].

6.2 EVS AMR-WB IO CNG operation

The CNG in the EVS AMR-WB interoperable modes use only the LP-CNG decoding scheme for rendering the AMR-WB compatible CN parameters. The complete CNG RX description of the EVS AMR-WB IO mode can be found in [2], clause 6.8.4.

7 Computational details and bit allocation

A computational description of comfort noise encoding and generation in form of an ANSI-C source code is given in [3] for the fix point implementation and in [4] for the floating point implementation.

For the EVS primary modes, the SID payload consists of 48 bits. The first bit of the payload determines the CNG scheme, where 0 stands for the LP-CNG and 1 for the FD-CNG.

For the EVS AMR-WB IO modes, the SID payload consists of 35 bits.

Annex A (informative): Change history

Change history							
Date	TSG #	TSG Doc.	CR	Rev	Subject/Comment	Old	New
2014-09	65	SP-140464			Presented at TSG SA#65 for approval		1.0.0
2014-09	65				Approved at TSG SA#65	1.0.0	12.0.0
2015-12	70				Version for Release 13	12.0.0	13.0.0

Change history							
Date	Meeting	TDoc	CR	Rev	Cat	Subject/Comment	New version
2017-03	75					Version for Release 14	14.0.0

History

Document history		
V14.0.0	April 2017	Publication