

ETSI TS 125 426 V13.0.0 (2016-01)



**Universal Mobile Telecommunications System (UMTS);
UTRAN Iur and Iub interface data transport &
transport signalling for DCH data streams
(3GPP TS 25.426 version 13.0.0 Release 13)**



ReferenceRTS/TSGR-0325426vd00

KeywordsUMTS

ETSI

650 Route des Lucioles
F-06921 Sophia Antipolis Cedex - FRANCE

Tel.: +33 4 92 94 42 00 Fax: +33 4 93 65 47 16

Siret N° 348 623 562 00017 - NAF 742 C
Association à but non lucratif enregistrée à la
Sous-Préfecture de Grasse (06) N° 7803/88

Important notice

The present document can be downloaded from:

<http://www.etsi.org/standards-search>

The present document may be made available in electronic versions and/or in print. The content of any electronic and/or print versions of the present document shall not be modified without the prior written authorization of ETSI. In case of any existing or perceived difference in contents between such versions and/or in print, the only prevailing document is the print of the Portable Document Format (PDF) version kept on a specific network drive within ETSI Secretariat.

Users of the present document should be aware that the document may be subject to revision or change of status. Information on the current status of this and other ETSI documents is available at

<http://portal.etsi.org/tb/status/status.asp>

If you find errors in the present document, please send your comment to one of the following services:

<https://portal.etsi.org/People/CommitteeSupportStaff.aspx>

Copyright Notification

No part may be reproduced or utilized in any form or by any means, electronic or mechanical, including photocopying and microfilm except as authorized by written permission of ETSI.

The content of the PDF version shall not be modified without the written authorization of ETSI.

The copyright and the foregoing restriction extend to reproduction in all media.

© European Telecommunications Standards Institute 2016.

All rights reserved.

DECT™, **PLUGTESTS™**, **UMTS™** and the ETSI logo are Trade Marks of ETSI registered for the benefit of its Members. **3GPP™** and **LTE™** are Trade Marks of ETSI registered for the benefit of its Members and of the 3GPP Organizational Partners.

GSM® and the GSM logo are Trade Marks registered and owned by the GSM Association.

Intellectual Property Rights

IPRs essential or potentially essential to the present document may have been declared to ETSI. The information pertaining to these essential IPRs, if any, is publicly available for **ETSI members and non-members**, and can be found in ETSI SR 000 314: *"Intellectual Property Rights (IPRs); Essential, or potentially Essential, IPRs notified to ETSI in respect of ETSI standards"*, which is available from the ETSI Secretariat. Latest updates are available on the ETSI Web server (<https://ipr.etsi.org>).

Pursuant to the ETSI IPR Policy, no investigation, including IPR searches, has been carried out by ETSI. No guarantee can be given as to the existence of other IPRs not referenced in ETSI SR 000 314 (or the updates on the ETSI Web server) which are, or may be, or may become, essential to the present document.

Foreword

This Technical Specification (TS) has been produced by the ETSI 3rd Generation Partnership Project (3GPP).

The present document may refer to technical specifications or reports using their 3GPP identities, UMTS identities or GSM identities. These should be interpreted as being references to the corresponding ETSI deliverables.

The cross reference between GSM, UMTS, 3GPP and ETSI identities can be found under <http://webapp.etsi.org/key/queryform.asp>.

Modal verbs terminology

In the present document "**shall**", "**shall not**", "**should**", "**should not**", "**may**", "**need not**", "**will**", "**will not**", "**can**" and "**cannot**" are to be interpreted as described in clause 3.2 of the [ETSI Drafting Rules](#) (Verbal forms for the expression of provisions).

"**must**" and "**must not**" are **NOT** allowed in ETSI deliverables except when used in direct citation.

Contents

Intellectual Property Rights	2
Foreword.....	2
Modal verbs terminology.....	2
Foreword.....	4
1 Scope	5
2 References	5
3 Definitions and abbreviations.....	6
3.1 Definitions	6
3.2 Abbreviations	6
4 Data Link Layer	7
4.1 ATM Transport Option	7
4.1.1 Protection Switching at ATM Layer	7
4.2 IP Transport Option.....	7
5 Iur and Iub Data Transport for DCH and E-DCH Data Streams.....	8
5.1 Introduction	8
5.2 ATM Transport Option	8
5.3 IP Transport Option.....	8
6 Transport Signalling Application for DCH and E-DCH Data Streams	9
6.1 Introduction	9
6.2 ALCAP in ATM Transport Option	9
6.3 ALCAP in IP Transport Option.....	9
7 Signalling Bearer for ALCAP on Iub Interface.....	9
7.1 Introduction	9
7.2 Signalling Bearer in ATM Transport Option	10
7.3 Signalling Bearer in IP Transport Option.....	10
8 Signalling Bearer for ALCAP on Iur Interface	10
8.1 Introduction	10
8.2 Signalling Bearer in ATM Transport Option	11
8.3 Signalling Bearer in IP Transport Option.....	11
9 Interworking between ATM and IP Transport Options	11
9.1 Introduction	11
9.2 Interworking Alternatives.....	11
Annex A (informative): Change history	13
History	14

Foreword

This Technical Specification has been produced by the 3rd Generation Partnership Project (3GPP).

The contents of the present document are subject to continuing work within the TSG and may change following formal TSG approval. Should the TSG modify the contents of the present document, it will be re-released by the TSG with an identifying change of release date and an increase in version number as follows:

Version x.y.z

where:

- x the first digit:
 - 1 presented to TSG for information;
 - 2 presented to TSG for approval;
 - 3 or greater indicates TSG approved document under change control.
- y the second digit is incremented for all changes of substance, i.e. technical enhancements, corrections, updates, etc.
- z the third digit is incremented when editorial only changes have been incorporated in the document.

1 Scope

The present document specifies the transport bearers for the DCH/E-DCH data streams on UTRAN Iur and Iub interfaces. The corresponding Transport Network Control plane is also specified. The physical layer for the transport bearers is outside the scope of the present document.

2 References

The following documents contain provisions which, through reference in this text, constitute provisions of the present document.

- References are either specific (identified by date of publication, edition number, version number, etc.) or non-specific.
- For a specific reference, subsequent revisions do not apply.
- For a non-specific reference, the latest version applies. In the case of a reference to a 3GPP document (including a GSM document), a non-specific reference implicitly refers to the latest version of that document *in the same Release as the present document*.

- [1] 3GPP TS 25.427: "UTRAN Iub/Iur interface user plane protocol for DCH data streams".
- [2] ITU-T Recommendation I.361 (1995-11): "B-ISDN ATM layer specification".
- [3] ITU-T Recommendation I.363.2 (2000-11): "B-ISDN ATM Adaptation Layer specification; Type 2 AAL".
- [4] ITU-T Recommendation I.366.1 (1998-06): "Segmentation and Reassembly Service Specific Convergence Sublayer for the AAL type 2".
- [5] ITU-T Recommendation Q.2630.1 (1999-12): "AAL type 2 signalling protocol (Capability Set 1)".
- [6] ITU-T Recommendation E.191 (2000-03): "B-ISDN addressing".
- [7] ITU-T Recommendation X.213 (1995-11): "Information Technology - Open Systems Interconnection - Systems Interconnection - Network Service Definition".
- [8] ITU-T Recommendation Q.2110 (1994-07): "B-ISDN ATM adaptation layer - Service Specific Connection Oriented Protocol (SSCOP)".
- [9] ITU-T Recommendation Q.2130 (1994-07): "B-ISDN signalling ATM adaptation layer - Service Specific Coordination Function for Support of Signalling at the User-Network Interface (SSCF at UNI)".
- [10] ITU-T Recommendation Q.2150.2 (1999-12): "AAL type 2 signalling transport converter on SSCOP)".
- [11] ITU-T Recommendation Q.2210 (1996-07): "Message transfer part level 3 functions and messages using the services of the ITU-T Recommendation Q.2140".
- [12] ITU-T Recommendation Q.2140 (1995-02): "B-ISDN ATM adaptation layer - Service Specific Coordination Function for Support of Signalling at the Network Node Interface (SSCF at NNI)".
- [13] ITU-T Recommendation Q.2150.1 (1999-12): "AAL type 2 signalling transport converter on broadband MTP".
- [14] IETF RFC 791 (1981-09): "Internet Protocol".
- [15] IETF RFC 1483 (1993-07): "Multiprotocol Encapsulation over ATM Adaptation Layer 5".
- [16] IETF RFC 2225 (1998-04): "Classical IP and ARP over ATM".

- [17] IETF RFC 768 (1980-08): "User Datagram Protocol".
- [18] IETF RFC 2960 (2000-10): "Stream Control Transmission Protocol".
- [19] IETF RFC 3332(2002-09): "Signalling System 7 (SS7) Message Transfer Part 3 (MTP3) – User Adaptation Layer (M3UA)".
- [20] ITU-T Recommendation I.630 (1999-02): "ATM protection switching".
- [21] ITU-T Recommendation Q.Imp2210 (1996-07): "Implementor's guide (03/99) for Recommendation Q.2210 (07/96)".
- [22] ITU-T Recommendation Q.2630.2 (2000-12): "AAL type 2 signalling protocol (Capability Set 2)".
- [23] IETF RFC 1661 (1994-07): "The Point-To-Point Protocol (PPP)".
- [24] IETF RFC 1662 (1994-07): "PPP in HDLC-like Framing".
- [25] IETF RFC 2507 (1999-02): "IP header compression".
- [26] IETF RFC 1990 (1996-08): "The PPP Multilink Protocol (MP)".
- [27] IETF RFC 2686 (1999-09): "The Multi-Class Extension to Multi-Link PPP".
- [28] IETF RFC 2509 (1999-02): "IP Header Compression over PPP".
- [29] IETF RFC 2460 (1998-12): "Internet Protocol, Version 6 (IPv6) Specification".
- [30] IETF RFC 2474 (1998-12): "Definition of the Differentiated Services Field (DS Field) in the IPv4 and IPv6 Headers".
- [31] IETF RFC 768 (1980-08): "User Datagram Protocol".
- [32] IETF RFC 3153 (2001-08): "PPP Multiplexing".
- [33] IETF RFC 2364 (1998-07): "PPP over AAL5".
- [34] IETF RFC 3031 (2001-01): "Multiprotocol Label Switching Architecture".
- [35] Void
- [36] ITU-T Recommendation E.164 (1997-05): "The international public telecommunication numbering plan".
- [37] IETF RFC 3309 (2002-09): "SCTP Checksum Change".
- [38] 3GPP TS 25.414: "UTRAN Iu Interface data transport & transport signalling".
- [39] 3GPP TS 25.401: "UTRAN overall description".

3 Definitions and abbreviations

3.1 Definitions

For the purposes of the present document, the following term and definition applies:

ALCAP: transport signalling protocol used to setup and tear down transport bearers

3.2 Abbreviations

For the purposes of the present document, the following abbreviations apply:

AAL2 ATM Adaptation Layer type 2

AESA	ATM End System Address
ATM	Asynchronous Transfer Mode
CPCS	Common Part Convergence Sublayer
CPS	Common Part Sublayer
DCH	Dedicated Channel
E-DCH	Enhanced DCH
HDLC	High level Data Link Control
HS-DSCH	High Speed Downlink Shared Channel
IP	Internet Protocol
LC	Link Characteristics
M3UA	SS7 MTP3 User Adaptation layer
ML/MC	Multi-link / Multi-class
MPLS	Multiprotocol Label Switching
MTP	Message Transfer Part
NNI	Network-Node Interface
NSAP	Network Service Access Point
PPP	Point to Point Protocol
PT	Path Type
SAAL	Signalling ATM Adaptation Layer
SAR	Segmentation and Reassembly
SCTP	Stream Control Transmission Protocol
SSCF	Service Specific Co-ordination Function
SSCOP	Service Specific Connection Oriented Protocol
SSCS	Service Specific Convergence Sublayer
SSSAR	Service Specific Segmentation and Reassembly sublayer
STC	Signalling Transport Converter
UDP	User Datagram Protocol
UNI	User-Network Interface

4 Data Link Layer

4.1 ATM Transport Option

ATM shall be used in the transport network user plane and transport network control plane according to ITU-T Rec. I.361 [2].

4.1.1 Protection Switching at ATM Layer

If redundancy of pathways at ATM Layer between RNC and Node B is supported, it shall be implemented using ATM Protection Switching according to ITU-T Rec. I.630 [20].

4.2 IP Transport Option

A UTRAN node supporting IP transport option shall support PPP protocol IETF RFC 1661 [23] with HDLC framing (IETF RFC 1662 [24]).

NOTE: This does not preclude the single implementation and use of any other L2/L1 protocols (e.g. PPPMux/AAL5/ATM (IETF RFC 3153 [32]), (IETF RFC 2364 [33]), PPP/AAL2/ATM, Ethernet, MPLS/ATM (IETF RFC 3031 [34]), etc.) fulfilling the UTRAN requirements towards the upper layers.

A UTRAN node supporting IP transport option and having interfaces connected via low bandwidth PPP links like E1/T1/J1 shall also support IP Header Compression (IETF RFC 2507 [25]) and the PPP extensions ML/MC-PPP (IETF RFC 1990 [26], IETF RFC 2686 [27]). In this case the negotiation of header compression (ITU-T Rec. I.630 [20]) over PPP shall be performed via IETF RFC 2509 [28].

5 Iur and Iub Data Transport for DCH and E-DCH Data Streams

5.1 Introduction

The Frame Protocol for DCH and E-DCH data streams (TS 25.427 [1]) is the user of the transport layer specified in the present document.

There are two options for the transport layer of the DCH and E-DCH data streams in Iur and Iub:

- 1) ATM based transport (ATM Transport Option)
- 2) IP based transport (IP Transport Option)

The following figure shows the protocol stacks of the two options.

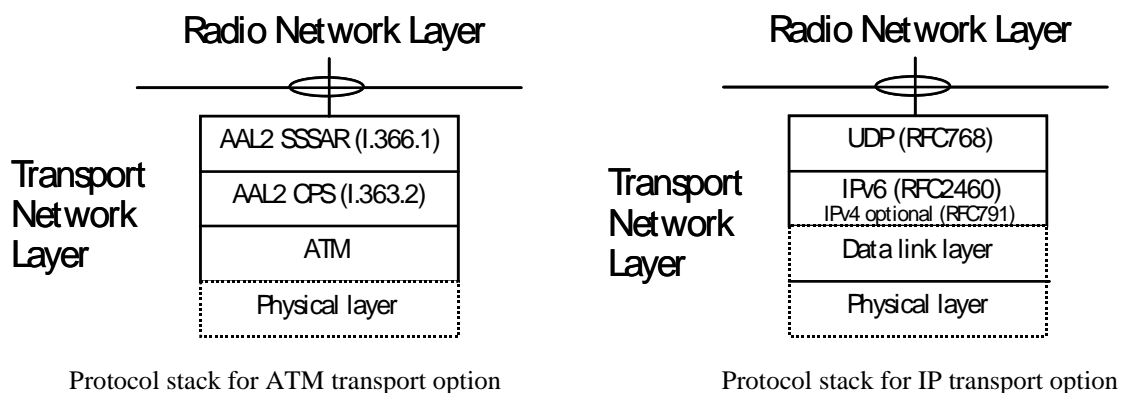

Figure 1: Transport network layer for DCH data streams over Iur and Iub interfaces

5.2 ATM Transport Option

Asynchronous Transfer Mode (ATM) (ITU-T Rec. I.361 [2]) and ATM Adaptation Layer type 2 (AAL2) (ITU-T Rec. I.363.2 [3], ITU-T Rec. I.366.1 [4]) are used as a transport layer for DCH and E-DCH data streams on Iur and Iub interfaces. Service Specific Segmentation and Reassembly (SSSAR) sublayer for AAL2 is used for the segmentation and reassembly of AAL2 SDUs.

5.3 IP Transport Option

UDP (IETF RFC 768 [17]) over IP shall be supported as the transport for DCH and E-DCH data streams on Iub and Iur interfaces. The data link layer is as specified in chapter 4.2.

An IP UTRAN Node shall support IPv6 (IETF RFC 2460[29]). The support of IPv4 (IETF RFC 791[14]) is optional.

NOTE: This does not preclude single implementation and use of IPv4.

IP dual stack support is recommended for the potential transition period from IPv4 to IPv6 in the transport network.

The transport bearer is identified by the UDP port number and the IP address (source UDP port number, destination UDP port number, source IP address, destination IP address).

The source IP address and destination IP address exchanged via Radio Network Layer on the Iur/Iub interface shall use the NSAP structure. See sub clause 6.1.8.2 of TS 25.401 [39].

IP Differentiated Services code point marking (IETF RFC 2474 [30]) shall be supported. The mapping between traffic categories and Diffserv code points shall be configurable by O&M. Traffic categories are implementation-specific and may be determined from the application parameters.

6 Transport Signalling Application for DCH and E-DCH Data Streams

6.1 Introduction

This chapter specifies the ALCAP protocol(s) to be used in Iur and Iub interfaces for DCH data streams.

6.2 ALCAP in ATM Transport Option

AAL2 signalling protocol Capability Set 2 (ITU-T Rec. Q.2630.2 [22]) is the signalling protocol to control AAL2 connections on Iub and Iur interfaces. ITU-T Rec. Q.2630.2 [22] adds new optional capabilities to ITU-T Rec. Q.2630.1 [5].

Binding ID provided by the radio network layer shall be copied in SUGR parameter of ESTABLISH.request primitive of ITU-T Rec. Q.2630.2 [22].

User Plane Transport bearers for Iur interface are established, in all normal cases released and optionally modified by the ALCAP in the Serving RNC. The binding identifier shall already be assigned and tied to a radio application procedure when the Establish Request message is received over the Iur interface in the Drift RNC.

User Plane Transport bearers for Iub interface are established, in all normal cases released and optionally modified by the ALCAP in the Controlling RNC. Binding identifier shall already be assigned and tied to a radio application procedure when the Establish Request message is received over the Iub interface in the Node B. In case of a Reset initiated by the CRNC, the ALCAP in the Node B shall release the transport bearers involved in the impacted Node B Communication Contexts. The Node B shall also initiate release of the user plane transport bearers for the removed dedicated channels that were remaining within the cell when the cell is deleted.

AAL2 transport layer addressing is based on embedded E.164 or other AESA variants of the NSAP addressing format (ITU-T Rec. E.191 [6], ITU-T Rec. X.213 [7]). Native E.164 addressing (ITU-T Rec. E.164 [36]) shall not be used.

The Link Characteristics parameter (LC) shall be included in the Establish Request message and in the Modification Request message of AAL2 signalling protocol.

If there is an AAL2 switching function in the transport network layer of the interface, the Path Type parameter (PT) may be included in the Establish Request message of AAL2 signalling protocol for prioritisation at ATM level.

If the value in either the Maximum CPS-SDU Bit Rate or the Average CPS-SDU Bit Rate of the Link Characteristics(LC) in AAL2 signalling messages as specified in reference ITU-T Rec. Q.2630.2 [22] is 2048 Kbit/s, it shall be interpreted as bit rate 2048 Kbit/s or higher.

NOTE: Separation of traffic (e.g. HS-DSCH, E-DCH) that is using this modified interpretation of Link Characteristics in ref. ITU-T Rec. Q.2630.2 [22] from other traffic is highly recommended. Otherwise the potential bursty nature of this specific traffic in combination with its unknown bit rate may decrease the QoS of all traffic within the same AAL type 2 path.

6.3 ALCAP in IP Transport Option

An ALCAP protocol is not required in case both UTRAN nodes are using the IP transport option.

Application of ALCAP in IP to ATM interworking case is defined in chapter 9 of this Technical Specification.

7 Signalling Bearer for ALCAP on Iub Interface

7.1 Introduction

This clause specifies the signalling bearer for the ALCAP on Iub interface.

7.2 Signalling Bearer in ATM Transport Option

SAAL-UNI (ITU-T Rec. Q.2110 [8], ITU-T Rec. Q.2130 [9]) is used as the signalling bearer for the AAL Type 2 Signalling protocol on Iub interface. Signalling Transport Converter for SSCOP is applied ITU-T Rec. Q.2150.2 [10]. The following figure shows the signalling bearer protocol stack for the ALCAP on Iub interface.

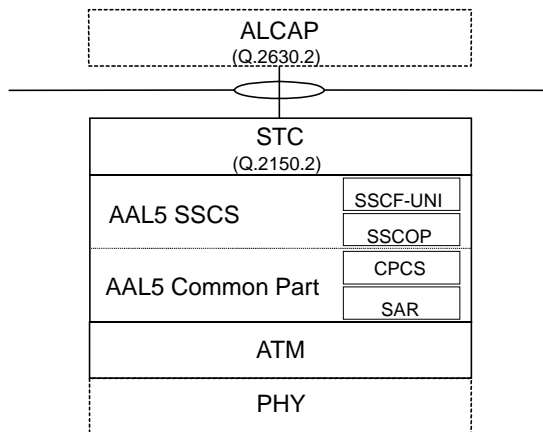

Figure 2: Signalling bearer for ALCAP on Iub interface

7.3 Signalling Bearer in IP Transport Option

An ALCAP protocol is not required in case both UTRAN nodes are using the IP transport option.

8 Signalling Bearer for ALCAP on Iur Interface

8.1 Introduction

This clause specifies the signalling bearer for the ALCAP on the Iur interface.

8.2 Signalling Bearer in ATM Transport Option

There are two protocol stacks specified for Iur ALCAP Signalling Bearer in ATM option - one based on MTP-3B (ITU-T Rec. Q.2210 [11], ITU-T Rec. Q.Imp2210 [21]) and SAAL-NNI (ITU-T Rec. Q.2140 [12], ITU-T Rec. Q.2110 [8]) and the other based on SCTP (IETF RFC 2960 [18]). Signalling Transport Converter for MTP-3B is applied (ITU-T Rec. Q.2150.1 [13]). MTP-3 User Adaptation Layer (M3UA) for SCTP is applied in IETF RFC 3332 [19]. Classical IP over ATM is specified in IETF RFC 2225 [16]. Multiprotocol Encapsulation over AAL5 is specified in IETF RFC 1483 [15]. The checksum method specified in IETF RFC 3309 [37] shall be used instead of the method specified in IETF RFC 2960 [18]. The following figure shows the signalling bearer protocol stacks for the ALCAP on Iur interface.

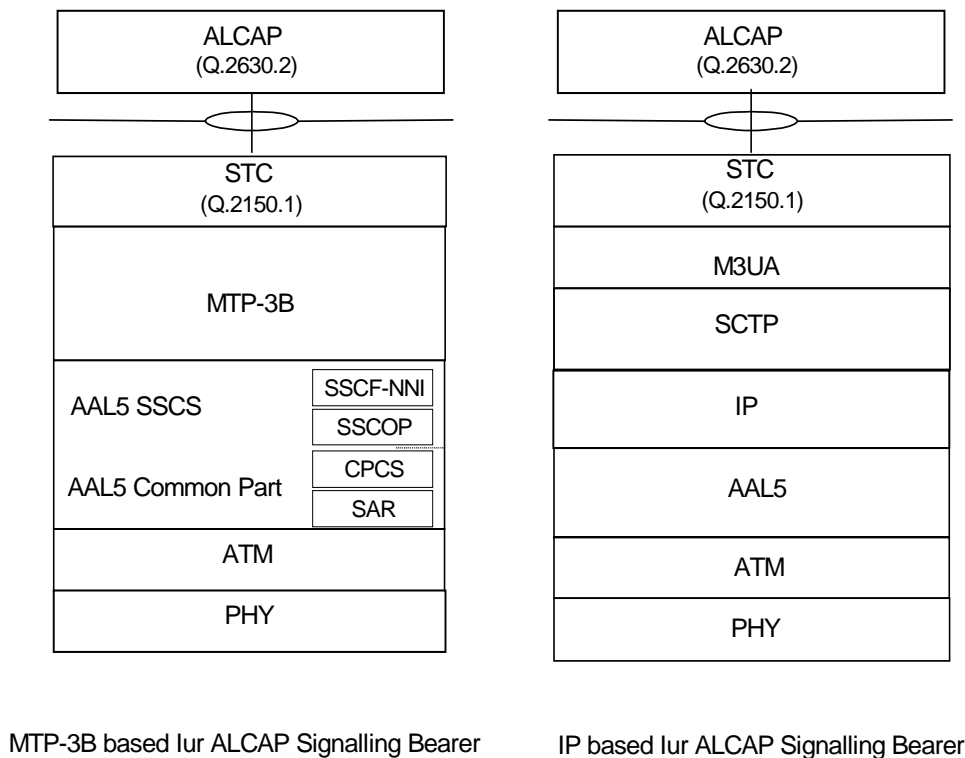

Figure 3: Signalling bearers for ALCAP on Iur interface

8.3 Signalling Bearer in IP Transport Option

An ALCAP protocol is not required in case both UTRAN nodes are using the IP transport option.

9 Interworking between ATM and IP Transport Options

9.1 Introduction

This clause specifies the interworking between IP and ATM transport options. A UTRAN node supporting IP transport option shall provide interworking to a UTRAN node supporting only ATM transport option.

9.2 Interworking Alternatives

For interworking with a UTRAN node supporting only ATM option, the UTRAN node supporting IP option shall additionally support at least one of the following interworking mechanisms:

- 1) ATM&IP dual stack. An ALCAP protocol is not required in this interworking solution.

Annex A of TS 25.414 [38] shows an example of protocols for the case the ATM&IP RNC/CN-node has no ATM connectivity.

- 2) An Interworking Function (IWF), either internal or external to the UTRAN node. AAL2 signalling protocol Capability Set 2 (ITU-T Rec. Q.2630.2 [22]) shall be supported as ALCAP protocol between the Interworking Function and the UTRAN node supporting ATM transport option.

Annex A of TS 25.414 [38] shows an example of a protocol stack for the bearer control protocol between the RNC/CN IP Node and its IWF for the case when the IWF is an external unit to the RNC/CN node. Other protocol stacks for this case are not precluded.

Annex A (informative): Change history

Date / TSG	TSG Doc.	CR	Rev	Subject/Comment	New
12/2008	-	-	-	Creation of Rel-8 version based on v7.1.0	8.0.0
12/2009	-	-	-	Creation of Rel-9 version based on v8.0.0	9.0.0
SP-49	SP-100629			Clarification on the use of References (TS 21.801 CR#0030)	9.0.1
03/2011				Creation of Rel-10 version based on v9.0.1	10.0.0
52	RP-110686	0053	-	Correction related to the References and clean-up of 25.426	10.1.0
09/2012				Update to Rel-11 version (MCC)	11.0.0
09/2014				Update to Rel-12 version (MCC)	12.0.0
12/2015				Update to Rel-13 version (MCC)	13.0.0

History

Document history		
V13.0.0	January 2016	Publication