

ETSI TS 124 604 V10.11.0 (2015-10)



**Digital cellular telecommunications system (Phase 2+);
Universal Mobile Telecommunications System (UMTS);
LTE;
Communication Diversion (CDIV) using IP Multimedia (IM)
Core Network (CN) subsystem;
Protocol specification
(3GPP TS 24.604 version 10.11.0 Release 10)**



Reference

RTS/TSGC-0124604vab0

Keywords

GSM,LTE,UMTS

ETSI

650 Route des Lucioles
F-06921 Sophia Antipolis Cedex - FRANCE

Tel.: +33 4 92 94 42 00 Fax: +33 4 93 65 47 16

Siret N° 348 623 562 00017 - NAF 742 C
Association à but non lucratif enregistrée à la
Sous-Préfecture de Grasse (06) N° 7803/88

Important noticeThe present document can be downloaded from:
<http://www.etsi.org/standards-search>

The present document may be made available in electronic versions and/or in print. The content of any electronic and/or print versions of the present document shall not be modified without the prior written authorization of ETSI. In case of any existing or perceived difference in contents between such versions and/or in print, the only prevailing document is the print of the Portable Document Format (PDF) version kept on a specific network drive within ETSI Secretariat.

Users of the present document should be aware that the document may be subject to revision or change of status. Information on the current status of this and other ETSI documents is available at
<http://portal.etsi.org/tb/status/status.asp>

If you find errors in the present document, please send your comment to one of the following services:
<https://portal.etsi.org/People/CommitteeSupportStaff.aspx>

Copyright Notification

No part may be reproduced or utilized in any form or by any means, electronic or mechanical, including photocopying and microfilm except as authorized by written permission of ETSI.

The content of the PDF version shall not be modified without the written authorization of ETSI.
The copyright and the foregoing restriction extend to reproduction in all media.

© European Telecommunications Standards Institute 2015.
All rights reserved.

DECT™, **PLUGTESTS™**, **UMTS™** and the ETSI logo are Trade Marks of ETSI registered for the benefit of its Members.
3GPP™ and **LTE™** are Trade Marks of ETSI registered for the benefit of its Members and of the 3GPP Organizational Partners.
GSM® and the GSM logo are Trade Marks registered and owned by the GSM Association.

Intellectual Property Rights

IPRs essential or potentially essential to the present document may have been declared to ETSI. The information pertaining to these essential IPRs, if any, is publicly available for **ETSI members and non-members**, and can be found in ETSI SR 000 314: *"Intellectual Property Rights (IPRs); Essential, or potentially Essential, IPRs notified to ETSI in respect of ETSI standards"*, which is available from the ETSI Secretariat. Latest updates are available on the ETSI Web server (<http://ipr.etsi.org>).

Pursuant to the ETSI IPR Policy, no investigation, including IPR searches, has been carried out by ETSI. No guarantee can be given as to the existence of other IPRs not referenced in ETSI SR 000 314 (or the updates on the ETSI Web server) which are, or may be, or may become, essential to the present document.

Foreword

This Technical Specification (TS) has been produced by ETSI 3rd Generation Partnership Project (3GPP).

The present document may refer to technical specifications or reports using their 3GPP identities, UMTS identities or GSM identities. These should be interpreted as being references to the corresponding ETSI deliverables.

The cross reference between GSM, UMTS, 3GPP and ETSI identities can be found under <http://webapp.etsi.org/key/queryform.asp>.

Modal verbs terminology

In the present document "**shall**", "**shall not**", "**should**", "**should not**", "**may**", "**need not**", "**will**", "**will not**", "**can**" and "**cannot**" are to be interpreted as described in clause 3.2 of the [ETSI Drafting Rules](#) (Verbal forms for the expression of provisions).

"**must**" and "**must not**" are **NOT** allowed in ETSI deliverables except when used in direct citation.

Contents

Intellectual Property Rights	2
Foreword.....	2
Modal verbs terminology.....	2
Foreword.....	6
1 Scope	7
2 References	7
3 Definitions and abbreviations.....	8
3.1 Definitions	8
3.2 Abbreviations	8
4 Communications Diversion (CDIV)	9
4.1 Introduction	9
4.2 Description	9
4.2.1 General description	9
4.2.1.1 Service description	9
4.2.1.2 Communication Forwarding Unconditional (CFU)	10
4.2.1.3 Communication Forwarding on Busy user (CFB).....	10
4.2.1.4 Communication Forwarding on no Reply (CFNR)	11
4.2.1.5 Communication Forwarding on Subscriber Not Reachable (CFNRc)	11
4.2.1.6 Communication Deflection (CD).....	11
4.2.1.7 Communication Forwarding on Not Logged-in (CFNL)	11
4.2.1.8 Void.....	12
4.3 Operational requirements	12
4.3.1 Provision/withdrawal.....	12
4.3.2 Requirements on the originating network side.....	13
4.3.3 Requirements in the network	13
4.4 Coding requirements	13
4.4.0 General.....	13
4.4.1 SIP-Messages.....	13
4.4.1.1 SIP messages for redirection	13
4.4.1.2 Void.....	14
4.4.2 Parameters.....	14
4.5 Signalling requirements.....	14
4.5.0 General.....	14
4.5.1 Activation/deactivation	14
4.5.1a Registration/erasure	15
4.5.1b Interrogation	15
4.5.2 Invocation and operation	15
4.5.2.1 Actions at the originating UA	15
4.5.2.2 Void.....	15
4.5.2.3 Void.....	15
4.5.2.4 Void.....	15
4.5.2.5 Void.....	15
4.5.2.6 Actions at the AS of the diverting User	15
4.5.2.6.0 General	15
4.5.2.6.1 Checking of the diversion limits.....	16
4.5.2.6.2 Setting of the diversion parameters by the AS	16
4.5.2.6.3 Diversion procedures at the diverting AS.....	19
4.5.2.6.4 Notification procedures of the originating user (Subscription Option)	21
4.5.2.6.5 Indication of communication diversion to the diverting user (subscription option)	22
4.5.2.6.6 Not reachable indication.....	23
4.5.2.7 Actions at the AS of the diverted-to user	23
4.5.2.8 Void.....	23
4.5.2.9 Void.....	23

4.5.2.10	Void.....	23
4.5.2.11	Void.....	23
4.5.2.12	Void.....	23
4.5.2.13	Void.....	23
4.5.2.14	Void.....	23
4.5.2.15	Actions at the diverted to UA.....	23
4.5.2.16	Actions at the diverting UA	24
4.6	Interaction with other services.....	24
4.6.1	Communication Hold (HOLD).....	24
4.6.2	Terminating Identification Presentation (TIP).....	24
4.6.3	Terminating Identification Restriction (TIR).....	24
4.6.4	Originating Identification Presentation (OIP).....	24
4.6.5	Originating Identification Restriction (OIR).....	25
4.6.6	Conference calling (CONF).....	25
4.6.7	Communication Diversion Services (CDIV)	25
4.6.8	Malicious Communication Identification (MCID)	25
4.6.9	Anonymous Communication Rejection and Communication Barring (ACR/CB)	25
4.6.10	Explicit Communication Transfer (ECT)	25
4.6.10.1	Actions at the diverting AS	25
4.6.10.1.1	Determine whether ECT is applied to the diverted communication	25
4.6.10.1.2	Handling of transfer requests.....	25
4.6.10.1.3	Actions when CDIV is invoked again by the transferred communication.....	26
4.6.11	Communication Waiting (CW).....	26
4.6.12	Completion of Communications to Busy Subscriber (CCBS).....	26
4.6.13	Advice Of Charge (AOC)	26
4.7	Interworking with other networks	27
4.7.1	Void	27
4.7.2	Void	27
4.7.3	Void	27
4.8	Parameter values (timers).....	27
4.8.1	No reply timer.....	27
4.8.2	Void	27
4.8.3	CDIV Indication Timer.....	27
4.9	Service Configuration for redirection services.....	27
4.9.1	Structure of the XML Document	27
4.9.1.0	General	27
4.9.1.1	Communication Diversion Element	28
4.9.1.1A	NoReplyTimer	28
4.9.1.2	Communication Diversion Rules	28
4.9.1.3	Communication Diversion Rule Conditions	29
4.9.1.4	Communication Diversion Rule Actions	30
4.9.1.5	Supported Actions and Conditions for Communication Diversion.....	31
4.9.2	XML Schema.....	31
4.9.3	XML schema for indication of supported conditions and actions.....	32
4.10	Void.....	33
Annex A (informative): Signalling Flows		34
A.1	Normal cases	34
A.1.1	Communication Forwarding unconditional.....	34
A.1.2	Communication Deflection	37
A.1.3	Communication forwarding on no reply	40
A.1.4	Communication Forwarding on Busy.....	43
A.1.5	Communication Forwarding Not Logged-in (CFNL)	46
A.1.6	Void.....	46
A.2	Interworking.....	46
A.2.1	Communication Forwarding unconditional.....	46
A.2.2	Communication Deflection	47
Annex B (informative): Example of filter criteria.....		49
Annex C (informative): Coding considerations		50

Annex D (informative): **Void**51

Annex E (normative): **Void**52

Annex F (informative): **Change history**53

History55

Foreword

This Technical Specification (TS) was been produced by ETSI Technical Committee Telecommunications and Internet converged Services and Protocols for Advanced Networking (TISPAN) and originally published as ETSI TS 183 004 [19]. It was transferred to the 3rd Generation Partnership Project (3GPP) in January 2008.

The contents of the present document are subject to continuing work within the TSG and may change following formal TSG approval. Should the TSG modify the contents of the present document, it will be re-released by the TSG with an identifying change of release date and an increase in version number as follows:

Version x.y.z

where:

- x the first digit:
 - 1 presented to TSG for information;
 - 2 presented to TSG for approval;
 - 3 or greater indicates TSG approved document under change control.
- y the second digit is incremented for all changes of substance, i.e. technical enhancements, corrections, updates, etc.
- z the third digit is incremented when editorial only changes have been incorporated in the document.

1 Scope

The present document specifies the stage 3, Protocol Description of the Communications Diversion (CDIV) supplementary services, based on stage one and two of the ISDN Communication diversion supplementary services. It provides the protocol details in the IP Multimedia (IM) Core Network (CN) subsystem based on the Session Initiation Protocol (SIP) and the Session Description Protocol (SDP).

The present document is applicable to User Equipment (UE) and Application Servers (AS) which are intended to support the CDIV supplementary service.

2 References

The following documents contain provisions which, through reference in this text, constitute provisions of the present document.

- References are either specific (identified by date of publication, edition number, version number, etc.) or non-specific.
- For a specific reference, subsequent revisions do not apply.
- For a non-specific reference, the latest version applies. In the case of a reference to a 3GPP document (including a GSM document), a non-specific reference implicitly refers to the latest version of that document *in the same Release as the present document*.

- [1] 3GPP TS 22.173: "Multimedia Telephony Service and supplementary services".
- [2] 3GPP TS 24.229: "IP Multimedia Call Control Protocol based on SIP and SDP".
- [3] IETF RFC 4244: "An Extension to the Session Initiation Protocol (SIP) for Request History Information".
- [4] 3GPP TS 24.623: "Extensible Markup Language (XML) Configuration Access Protocol (XCAP) over the Ut interface for Manipulating Supplementary Services".
- [5] IETF RFC 4566: "SDP: Session Description Protocol".
- [6] IETF RFC 3261: "SIP: Session Initiation Protocol".
- [7] IETF RFC 3966: "The tel URI for Telephone Numbers".
- [8] IETF RFC 3325: "Private Extensions to the Session Initiation Protocol (SIP) for Asserted Identity within Trusted Networks".
- [9] 3GPP TS 24.611: "Anonymous Communication Rejection (ACR) and Communication Barring (CB); Protocol specification".
- [10] Void.
- [11] 3GPP TS 24.628: "Common Basic Communication procedures; Protocol specification".
- [12] 3GPP TS 23.002: "Network Architecture".
- [13] Void.
- [14] IETF RFC 4458: "Session Initiation Protocol (SIP) URIs for Applications such as Voicemail and Interactive Voice Response (IVR)".
- [15] IETF RFC 3265: "Session Initiation Protocol (SIP) -Specific Event Notification".
- [16] 3GPP TS 24.629: "Explicit Communication Transfer (ECT); Protocol specification".
- [17] IETF RFC 3515: "The Session Initiation Protocol (SIP) Refer Method".

- [18] IETF RFC 4745: "Common Policy: A Document Format for Expressing Privacy Preferences".
- [19] ETSI TS 183 004 V2.4.0: "Telecommunications and Internet converged Services and Protocols for Advanced Networking (TISPAN); PSTN/ISDN simulation services: Communication Diversion (CDIV); Protocol specification".
- [20] IETF RFC 5627 (October 2009): "Obtaining and Using Globally Routable User Agent URIs (GRUUs) in the Session Initiation Protocol (SIP)".
- [21] OMA-TS-XDM-Core-V1_1: "XML Document Management (XDM) Specification", Version 1.1.
- [22] 3GPP TS 24.238: "Session Initiation Protocol (SIP) based user configuration".
- [23] Void.
- [24] IETF RFC 3326: "The Reason Header Field for the Session Initiation Protocol (SIP)".
- [25] Void.
- [26] IETF RFC 3023 (January 2001): "XML Media Types".
- [27] IETF RFC 4288 (December 2005): "Media Type Specifications and Registration Procedures".

3 Definitions and abbreviations

3.1 Definitions

For the purposes of the present document, the terms and definitions given in 3GPP TS 22.173 [1] and the following apply:

CDIV Session Identifier URI: URI created and inserted by a diverting AS that is routed through the same AS

NOTE: This is used to solve the service interaction of CDIV and ECT.

escaped character: See IETF RFC 3261 [6].

transferee: party being transferred to the transfer target

transferor: party initiating the transfer

transfer target: party that the existing communication is transferred to

NOTE: After transfer the transferee and the transfer target are in communication with each other.

3.2 Abbreviations

For the purposes of the present document, the following abbreviations apply:

ACM	Address Complete Message
ACR	Anonymous Communication Rejection
ANM	ANswer Message
AS	ApplicAtion Server
CB	CommuniCation Barring
CD	CommuniCation Deflection
CDIV	CommuniCation DIVersion
CFB	CommuniCation Forwarding Busy
CFNL	CommuniCation Forwarding on Not Logged-in
CFNR	CommuniCation Forwarding No Reply
CFNRc	CommuniCation Forwarding on subscriber Not Reachable
CFU	CommuniCation Forwarding Unconditional
CONF	CONFerence

CPG	Call ProGress message
CSCF	Call Session Control Function
ECT	Explicit Communication Transfer
HOLD	communication HOLD
IAM	Initial Address Message
IFC	Initial Filter Criteria
IMS	IP Multimedia Subsystem
IP	Internet Protocol
ISDN	Integrated Service Data Network
ISUP	Integrated Service digital network User Part
MCID	Malicious Communication IDentification
MGCF	Media Gateway Control Function
OCB	Outgoing Communication Barring
OIP	Originating Identification Presentation
OIR	Originating Identification Restriction
P-CSCF	Proxy-Call Session Control Function
PSTN	Public Switched Telephone Network
RTP	Real-Time Transport Protocol
S-CSCF	Server-Call Session Control Function
SDP	Session Description Protocol
SIP	Session Initiation Protocol
TIP	Terminating Identification Presentation
TIR	Terminating Identification Restriction
UA	User Agent
UE	User Equipment
URI	Universal Resource Identifier
XCAP	XML Configuration Access Protocol
XML	eXtensible Markup Language

4 Communications Diversion (CDIV)

4.1 Introduction

The Communications Diversion (CDIV) service enables diverting user, to divert the communications addressed to diverting user to another destination.

4.2 Description

4.2.1 General description

4.2.1.1 Service description

The service description of the following CDIVs services CFU, CFB, CFNR and CD is based on the PSTN/ISDN supplementary services, whereas CFNL is a CDIV service based on requirements for IP based networks and CFNRc is based on requirements for mobile networks.

Generally the following requirements are expected to be fulfilled:

- The service provides for the user or the network to identify an alternative destination for an IP multimedia session or individual media of an IP multimedia session.
- The service provides for redirection to be initiated at various stages of an IP Multimedia session. For example:
 - Prior to the set up of an IP Multimedia session.
 - During the initial request for an IP Multimedia session (CFU).
 - During the establishment of an IP Multimedia session (CD).

- The service provides redirection to be applied for all Multimedia sessions unconditionally or it can be caused by any of a set list of events or conditions. Typical causes could be:
 - Identity of the originating user.
 - Presence of the originating or destination party.
 - If the destination party is already in a session (CFB).
 - If the destination party is unreachable or unavailable in some other way (CFNL; CFNR, CFNRc).
 - If the destination party does not respond (CFNR).
 - After a specified alerting interval (CFNR).
 - User's preference on routing for specific IP Multimedia session based on the capabilities of multiple UEs sharing the same IMS service subscription.
 - The sending party, receiving party or the network on their behalf, may initiate redirection to alternative destinations.
 - The service provides for the user to subscribe to receive notifications of his/her communications diversions

The following services describe applications based on a subset of the above-mentioned requirements to provide user different possibilities to divert a communication.

It should be possible that a user has the option to restrict receiving communications that are forwarded.

4.2.1.2 Communication Forwarding Unconditional (CFU)

The CFU service enables a served user to have the network redirect to another user communications which are addressed to the served user's address. The CFU service may operate on all communications, or just those associated with specified services. The served user's ability to originate communications is unaffected by the CFU supplementary service. After the CFU service has been activated, communications are forwarded independent of the status of the served user.

As a service provider option, a subscription option can be provided to enable the served user to receive a reminder indication that the CFU service has been activated. This indication is provided when the served user originates a communication and if the CFU service has been activated for the served user's address and for the service requested for the communication.

The maximum number of diversions permitted for each communication is a service provider option. The service provider defines the upper limit of diversions. When counting the number of diversions, all types of diversion are included.

4.2.1.3 Communication Forwarding on Busy user (CFB)

The CFB service enables a served user to have the network redirect to another user communications which are addressed to the served user's address and meet busy. The CFB service may operate on all communications, or just those associated with specified services. The served user's ability to originate communications is unaffected by the CFB supplementary service.

As a service provider option, a subscription option can be provided to enable the served user to receive a reminder indication that the CFB service has been activated. This indication is provided when the served user originates a communication and if the CFB service has been activated for the served user's address and for the service requested for the communication.

The maximum number of diversions permitted for each communication is a service provider option. The service provider defines the upper limit of diversions. When counting the number of diversions, all types of diversion are included.

For more information on the procedures for determination of the busy condition see 3GPP TS 24.628 [11].

4.2.1.4 Communication Forwarding on no Reply (CFNR)

The CFNR service enables a served user to have the network redirect to another user communications which are addressed to the served user's address, and for which the connection is not established within a defined period of time. The CFNR service may operate on all communications, or just those associated with specified services. The served user's ability to originate communications is unaffected by the CFNR supplementary service.

The CFNR service can only be invoked by the network after the communication has been offered to the served user and an indication that the called user is being informed of the communication has been received.

As a service provider option, a subscription option can be provided to enable the served user to receive a reminder indication that the CFNR service has been activated. This indication is provided when the served user originates a communication and if the CFNR service has been activated for the served user's address and for the service requested for the communication.

The maximum number of diversions permitted for each communication is a service provider option. The service provider defines the upper limit of diversions. When counting the number of diversions, all types of diversion are included.

4.2.1.5 Communication Forwarding on Subscriber Not Reachable (CFNRc)

The CFNRc service enables a user to have the network redirect all incoming communications, when the user is not reachable (e.g. there is no IP connectivity to the user's terminal), to another user. The CFNRc service may operate on all communications, or just those associated with specified services. The user's ability to originate communications is unaffected by the CFNRc supplementary service.

As a service provider option, a subscription option can be provided to enable the user to receive an indication that the CFNRc service has been activated. This indication is provided when the user originates a communication if the CFNRc service has been activated for the user and for the service requested for the communication.

The maximum number of diversions permitted for each communication is a service provider option. The service provider defines the upper limit of diversions. When counting the number of diversions, all types of diversion are included.

4.2.1.6 Communication Deflection (CD)

The CD service enables the served user to respond to an incoming communication by requesting redirection of that communication to another user. The CD service can only be invoked before the connection is established by the served user, i.e. in response to the offered communication (before ringing), i.e. CD Immediate, or during the period that the served user is being informed of the communication (during ringing). The served user's ability to originate communications is unaffected by the CD supplementary service.

The maximum number of diversions permitted for each communication is a network provider option. The network provider defines the upper limit of diversions. When counting the number of diversions, all types of diversion are included.

4.2.1.7 Communication Forwarding on Not Logged-in (CFNL)

The Communication Forwarding on Not Logged-in (CFNL) service enables a served user to redirect incoming communications which are addressed to the served user's address, to another user (forwarded-to address) in case the served user is not registered (logged-in). The CFNL service may operate on all communications, or just those associated with specified basic services.

As a service provider option, a subscription option can be provided to enable the served user to receive a reminder indication that the CFNL service has been activated. This indication is provided when the served user logs out according to procedures described in IETF RFC 3261 [6].

The maximum number of diversions permitted for each communication is a service provider option. The service provider defines the upper limit of diversions. When counting the number of diversions, all types of diversion are included.

4.2.1.8 Void

4.3 Operational requirements

4.3.1 Provision/withdrawal

The CDIV services (Communication forwarding unconditional, Communication forwarding busy, Communication forwarding no reply, Communication forwarding not logged-in, Communication deflection and Communication Diversion Notification) is provided after prior arrangement with the service provider.

The CDIV services are withdrawn at the served user's request or for administrative reasons.

The CDIV supplementary services can be offered separately with subscription options. For each subscription option, only one value can be selected. These subscription options are part of the call diversion profile for the served user. The subscription options are shown in table 4.3.1.1.

Table 4.3.1.1: Subscription options for CDIV services

Subscription options	Value	Applicability
Served user receives indication that a communication has been forwarded (indication of communication diversion to the diverting user).	No (default)	CFU
	Yes	CFB CFNR CFNRc
Originating user receives notification that his communication has been diverted (forwarded or deflected).	No	CFU
	Yes (default)	CFB CFNR CFNRc CFNL CD
Served user allows the presentation of diverted to URI to originating user in diversion notification.	No	CFU
	Not reveal as GRUU	CFB CFNR CFNRc
	Yes (default)	CFNL CD
Served user receives reminder indication on outgoing communication that CDIV is currently activated.	No (default)	CFU
	Yes	CFB CFNR CFNRc CFNL
Served user allows the presentation of his/her URI to diverted-to user.	No	CFU
	Not reveal as GRUU	CFB CFNR CFNRc
	Yes (default)	CFNL CD
Served user allows the presentation of his/her URI to originating user in diversion notification.	No	CFU
	Not reveal as GRUU	CFB CFNR CFNRc
	Yes (default)	CFNL CD

The following network provider options are available for the CDIV services:

Table 4.3.1.2: Network provider options for CDIV services

Network provider option	Value	Applicability
Served user communication retention on invocation of diversion (forwarding or deflection).	Retain communication to the served user until alerting begins at the diverted-to user	CFNR CD
	Clear communication to the served user on invocation of call diversion	
Served user communication retention when diverting is rejected at diverted-to user.	Continue to alert the diverting user (see note 1)	CFNR CD
	No action at the diverting user (see note 2)	
Subscription option is provided for "served user receives reminder indication on outgoing communication that CDIV is currently activated".	No	CFU CFB CFNR CFNRc CFNL
	Yes	
Total number of all diversions for each communication.	Maximum number of diverted connections (upper limit is based on operator policy)	CFU CFB CFNR CFNRc CFNL CD
CDIV Indication Timer.	Timer duration is a service provider option	CFU CFB CFNR CFNRc CFNL CD
Communication forwarding on no reply timer.	Timer default duration is a service provider option (NOTE 3)	CFNR
NOTE 1: This applies to the retention of the communication at invocation of communication diverting.		
NOTE 2: This applies to the clearing communication option on invocation of communication diverting.		
NOTE 3: As a network provider option, it shall be possible to change the timer duration by the served user.		

4.3.2 Requirements on the originating network side

No specific requirements are needed in the network.

4.3.3 Requirements in the network

No specific requirements are needed in the network.

Based on the Initial Filter Criteria (IFC) Rules, indicating that the served user is subscribed to the CDIV supplementary services, the communication is be forwarded to an AS.

NOTE: An example of the use of IFC is shown in annex B.

4.4 Coding requirements

4.4.0 General

3GPP TS 24.229 [2] defines the messages and parameters for this supplementary service. The following messages and parameters are used to support the Communication diversion service due to fulfil the requirements.

4.4.1 SIP-Messages

4.4.1.1 SIP messages for redirection

Table 4.4.1.1 shows the SIP messages that are used due to the coding rules in 3GPP TS 24.229 [2].

Table 4.4.1.1: SIP Header information for redirection

SIP Message	Reference	SIP Header
INVITE	[3] [8] [14] [20]	History-Info header Privacy header cause-param URI parameter "gr" URI parameter
180 (Ringing)	[3] [8] [14] [20]	History-Info header Privacy header cause-param URI parameter "gr" URI parameter in the Contact
181 (Call Is Being Forwarded)	[3] [8] [14] [20]	History-Info header Privacy header cause-param URI parameter "gr" URI parameter in the Contact
200 (OK) response	[3] [8] [14] [20]	History-Info header Privacy header cause-param URI parameter "gr" URI parameter in the Contact
302 (Moved Temporarily) (see note)	[2] [14]	Contact header cause-param URI parameter
NOTE: The 302 (Moved Temporarily) response is in the present document only used for the CD services.		

More information on the cause-param URI parameter is given in annex C.

An AS that implements the CDIV service shall support the REFER method IETF RFC 3515 [17], to be able to handle the interaction with 3GPP TS 24.629 [16].

4.4.1.2 Void

4.4.2 Parameters

The Privacy header is described in 3GPP TS 24.229 [2]. The present document refers for the History-Info header to IETF RFC 4244 [3], for the Privacy header and P-Asserted-Identity to IETF RFC 3325 [8], for GRUU to IETF RFC 5627 [20] and for the cause-param to IETF RFC 4458 [14].

4.5 Signalling requirements

4.5.0 General

Configuration of supplementary services by the user should:

- take place over the Ut interface using XCAP as enabling protocol as described in 3GPP TS 24.623 [4]; or
- use SIP based user configuration as described in 3GPP TS 24.238 [22];

NOTE: Other possibilities for user configuration, such as web-based provisioning or pre-provisioning by the operator are outside the scope of the present document, but are not precluded.

The enhancements to the XML schema for use over the Ut interface is described in subclause 4.9.

4.5.1 Activation/deactivation

The services CFU, CFB, CFNR, CFNL, CFNRc and CD are individually activated at provisioning or at the subscriber's request.

The services CFU, CFB, CFNR, CFNL, CFNRc and CD are individually deactivated at withdrawal or at the subscriber's request.

4.5.1a Registration/erasure

For registration of diversion information for the services CFU, CFB, CFNR, CFNL, CFNRc and CD, the mechanisms specified in subclause 4.5.0 should be used. The diverted-to party address of the services CFU, CFB, CFNR, CFNL, CFNRc and CD can individually be registered at the subscriber's request by using the mechanisms specified in subclause 4.5.0.

For erasure of diversion information for the services CFU, CFB, CFNR, CFNL, CFNRc and CD, the mechanisms specified in subclause 4.5.0 should be used. The diverted-to party address of the services CFU, CFB, CFNR, CFNL, CFNRc and CD can individually be erased at the subscribers request by using the mechanisms specified in subclause 4.5.0.

4.5.1b Interrogation

For interrogation of the services CFU, CFB, CFNR, CFNL, CFNRc and CD, the mechanisms specified in subclause 4.5.0 should be used.

For interrogation of the supported conditions and actions that can be used in the network the Ut interface should be used.

4.5.2 Invocation and operation

4.5.2.1 Actions at the originating UA

A UE supporting CDIV services shall support origination of requests in the IM CN subsystem (as specified in 3GPP TS 24.229 [2]).

When communication diversion has occurred on the served user side and the network option "*Originating user receives notification that his communication has been diverted (forwarded or deflected)*" is set to true, the originating UA may receive a 181 (Call Is Being Forwarded) response according to the procedures described in 3GPP TS 24.229 [2].

The Information given by the History-Info header could be displayed by the UA if it is a UE.

4.5.2.2 Void

4.5.2.3 Void

4.5.2.4 Void

4.5.2.5 Void

4.5.2.6 Actions at the AS of the diverting User

4.5.2.6.0 General

If the session is subject to diversion the AS of the diverting user:

- if modification of the To header is required as specified in the procedures of this subclause, shall operate as an AS providing 3rd party call control, and specifically as a routeing B2BUA, as specified in subclause 5.7.5 of 3GPP TS 24.229 [2];
- otherwise, shall operate as either an AS acting as a SIP proxy as specified in subclause 5.7.4 of 3GPP TS 24.229 [2] or an AS providing 3rd party call control, and specifically as a routeing B2BUA, as specified in subclause 5.7.5 of 3GPP TS 24.229 [2]

NOTE: For the case when the session is not subject to diversion and CDIV, according the requirements in this document, is the only service being applied by the AS, then the AS only needs to act as a SIP proxy. If additional services are applied, then the AS might need to act as a routeing B2BUA..

4.5.2.6.1 Checking of the diversion limits

When receiving an INVITE request and the AS determines that the AS shall divert a communication the AS shall check if diverting the communication exceeds the number of diversions allowed within the network. The AS shall calculate the number of diversions by examination of the History-Info header;

- using the entries including a cause-param URI parameter with cause values specified in subclause 4.5.2.6.2.2; or
- examine the entries in the Index entries parameter,

to see if another diversion is allowed due to network provider allowed_limit of diversions

If the number of diversions exceeds the given limit then the AS shall send one of the following responses to the originating user:

- a) if communication diversion forwarding busy a 486 (Busy Here);
- b) if communication forwarding no reply, a 480 (Temporarily Unavailable);
- c) if communication forwarding unconditional a 480 (Temporarily Unavailable);
- d) if communication deflection, a 480 (Temporarily Unavailable);
- e) if communication forwarding not logged in, a 480 (Temporarily Unavailable); or
- f) if communication forwarding not reachable, a 480 (Temporarily Unavailable)

NOTE: It is based on operator policy that the communication can be delivered to the latest diverting party when it is known.

In all cases a Warning header field indicating that the communication is released due to the extension of diversion hops (e.g. "Too many diversions appeared") shall be sent.

4.5.2.6.2 Setting of the diversion parameters by the AS

4.5.2.6.2.1 Overview

After checking the limit of diversions the following sets the retargeted INVITE request according to the procedures in subclause 4.5.2.6.2.

4.5.2.6.2.2 Diversion where served user is not last in received History-Info header

If an AS determines that the AS shall divert a communication and if any of the following conditions apply for the received INVITE request:

- no History-Info header received; or
- a History-Info header is received in which the last history-info entry contains no hi-targeted-to-uri element for the served user.

The AS shall set the following information in the retargeted INVITE request:

- the diverting parties address;
- the diverted-to party address;
- diversion information.

The AS shall include or modify the following header fields with the specified values:

- a) **The Request URI** - set to the SIP URI where the communication is to be diverted to (see <target> element in subclause 4.9.1.4). In advance of this, if the <target> element contains a tel URI, the AS shall convert the tel URI into a SIP URI as specified in RFC 3261 [6], and include a user parameter set to "phone".

The AS shall set in the SIP URI the cause-param parameter (redirecting reason and redirecting indicator) also included in the History-Info header field according to the diversion conditions. The mapping between the diversion conditions and the coding of the cause-param parameter is as follows:

- if communication forwarding busy, the cause value "486" as defined by RFC 4458 [14];
- if communication forwarding no reply, the cause value "408" as defined by RFC 4458 [14];
- if communication forwarding unconditional, the cause value "302" as defined by RFC 4458 [14];
- if communication deflection (Immediate Response), the cause value "480" as defined by RFC 4458 [14];
- if communication forwarding not logged in, the cause value "404" as defined by RFC 4458 [14];
- if communication deflection during alerting, the cause value "487" as defined by RFC 4458 [14]; and
- if communication forwarding on subscriber not reachable, the cause value "503" as defined by RFC 4458 [14];

b) The History-Info header field - two hist-info entries that shall be generated.

- 1) The first entry includes the hi-targeted-to-uri of the served user.

The AS shall include the privacy header "history" within the hi-targeted-to-uri in the escaped form, if:

- the served user wishes privacy (e.g. the served user is subscribed to the OIR Service); or
- the served user has the subscription option "Served user allows the presentation of his/her URI to diverted-to user" set to false.

Otherwise, if the first entry contains the "gr" parameter and the subscription option "Served user allows the presentation of his/her URI to *diverted-to* user" is set to "not-reveal-as-GRUU", then the AS shall change the first entry as follows:

- replace the first entry with the public user identity of the served user.

If the diversion is based on a SIP response from the served user, a Reason header in escaped form shall be included in accordance with RFC 4244 [3].

The Index shall be set or incremented according to the Basic Forwarding rules specified in subclause 4.3.3.1.3. "Indexing in the History-Info Header" of IETF RFC 4244 [3].

When a Reason header field or a Privacy header field needs to be included in the hi-targeted-to-uri, the hi-targeted-to-uri shall be a SIP URI.

- 2) The second entry includes the new Request URI as described under bullet a) as hi-targeted-to-uri.

NOTE: In accordance with RFC 4458 [14], hi-targeted-to-uri will contain a cause-param in non-escaped format.

c) The To header field:

If the served user does not want to reveal its identity to the diverted-to party, then the AS shall change the To header field to the URI where the communication is diverted to. The served user does not want to reveal its identity when one of the following conditions holds true:

- if the served user wishes privacy (e.g. the served user is subscribed to the OIR Service); or
- if the served user has the subscription option "Served user allows the presentation of his/her URI to diverted-to user" set to "false".

Otherwise, if the To header contains the "gr" parameter and the served user has the subscription option "Served user allows the presentation of his/her URI to diverted-to user" set to "not-reveal-as-GRUU", then the AS shall change the To header field to a public user identity of the served user.

In all other cases the AS shall not change the To header.

4.5.2.6.2.3 Diversion with served user last in received History-Info header

If an AS determines that the communication shall be diverted the AS shall apply the procedure in the present subclause if the received INVITE request includes a History-Info header, which in the last history-info entry includes a hi-targeted-to-uri with an entry for the served user, encoded as in subclause 4.5.2.6.2.2. In this case the AS shall add a new history-info entry to the History-Info header field according to the rules defined in IETF RFC 4244 [3]. The following information is added to the retargeted request:

- the diverted-to party address;
- diversion information.

The AS shall add or modify the following header fields with the specified values;

- a) **Request URI** - set to the SIP URI where the communication is to be diverted to (see <target> element in subclause 4.9.1.4). In advance of this, if the <target> element contains a tel URI, the AS shall convert the tel URI into a SIP URI as specified in RFC 3261 [6], and include a user parameter set to "phone".

The AS shall add the cause-param as defined by RFC 4458[14] to the request URI. The mapping between the diversion conditions and the coding of the cause-param parameter shall be as defined under bullet a in subclause 4.5.2.6.2.2.

- b) **History-Info header field** shall be modified in accordance with RFC 4244 [3]. The history entry corresponding to previous request URI can be modified. One history entry is added.

1) The existing history entry corresponding to the previous request URI shall be treated as follows: if the Privacy header field does not contain "history", the privacy header "history" in escaped format shall be added or modified within the hi-targeted-to-uri, if:

- the served user wishes privacy (e.g. the served user is subscribed to the OIR Service); or
- the served user has the subscription option "Served user allows the presentation of his/her URI to diverted-to user" set to false.

If the history entry representing the served user contains the "gr" parameter and the subscription option "Served user allows the presentation of his/her URI to *diverted-to* user" set to "not-reveal-as-GRUU", the AS shall change the history entry to a public user identity of the served user.

If the diversion is based on a SIP response from the served user, a Reason header in escaped form shall be included in the hi-targeted-to-uri in accordance with RFC 4244 [3].

When a Reason header field or a Privacy header field needs to be included in the existing hi-targeted-to-uri that is a tel URI, the hi-targeted-to-uri shall be first converted to a SIP URI.

- 2) A history entry shall be added containing the new Request URI as described under bullet a) as hi-targeted-to-uri.

NOTE: In accordance with RFC 4458 [14], hi-targeted-to-uri will contain a cause-param in non-escaped format.

c) **To header:**

If the served user does not want to reveal its identity to the diverted-to party, then the To header shall be changed to the URI where the communication is diverted to. The served user does not want to reveal its identity when one of the following conditions holds true:

- if the served user wishes privacy (e.g. the served user is subscribed to the OIR Service); or
- if the served user has the subscription option "Served user allows the presentation of his/her URI to diverted-to user" set to false.

Otherwise, if the To header contains the "gr" parameter and the served user has the subscription option "Served user allows the presentation of his/her URI to *diverted-to* user" set to "not-reveal-as-GRUU", then the To header shall be changed to a public user identity of the served user.

In all other cases the To header shall not be changed.

4.5.2.6.2.4 Overview of the operation

Figure 4.5.2.6.2.4 shows the example of a communication path for multiple diversions.

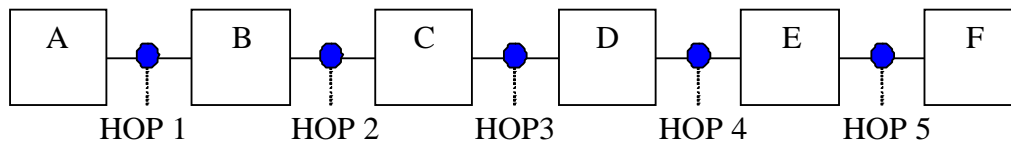

Figure 4.5.2.6.2.4: Originally A calls B Information transferred in the INVITE request

Table 4.5.2.6.2.4 shows which parameters and header fields that are added or modified in a diversion AS.

Table 4.5.2.6.2.4: Parameter information for multiple redirections

	HOP 1	HOP 2	HOP 3	HOP 4	HOP 5
Number Information:					
P-Asserted-Identity	A	A	A	A	A
Request URI	B	C	D	E	F
hi-entry		B C	B C D	B, C D E	B, C, D E F
Information added:					
hi-targeted-to-uri (NOTE 4)	B	C	No changes	D	No changes
Reason header (NOTE 2)	V		V	V	V
cause-param (NOTE 3)		U	No changes	U	No changes
Privacy	W		W	W	W
Hi-index (NOTE 1)	index 1	index 2	index 3	index 4	index 5

U = Value for the cause-param parameter as specified in 4.5.2.6.2.2 and 4.5.2.6.2.3

V = Value in accordance with the rules in RFC 4244 [3].

W = privacy value (history) or (none) or no entry.

NOTE 1: The hi-index field shall be set or incremented according to the basic forwarding rules as specified in subclause 4.3.3.1.3 of RFC 4244 [3].

NOTE 2: The encoding of the reason header and the contained protocol-cause parameter are specified in RFC 3326 [24]. It is embedded in the hi-targeted-to-uri of the history info header in escaped format according to the rules in RFC 4244 [3].

NOTE 3: The cause-param is specified in RFC 4458 [14]. It is embedded in the hi-targeted-to-uri of the history info header in non-escaped format according to the rules in RFC 4458 [14].

NOTE 4: If the received hi-targeted-to-uri is a tel URI, it is converted to a SIP URI if the Reason or the Privacy header field has to be embedded.

4.5.2.6.3 Diversion procedures at the diverting AS

The diverting AS shall continue the communication depending on the service that is causing the diversion:

- 1) Communication Forwarding Unconditional or Communication Forwarding Busy network determined user busy or Communication forwarding on Not Logged in

The AS shall continue in the following manner:

- If the notification procedure of the originating user is supported then the originating user shall be notified as described in the subclause 4.5.2.6.4.
- An INVITE request containing the diverted-to URI shall sent to the (outgoing) S-CSCF. The INVITE request shall includes the parameter information as shown in table 4.5.2.6.2.4 and described in subclause 4.5.2.6.2.
- If the served user has subscribed to the indication of communication diversion to the diverting user, then the served user will be notified of the communication diversion as described in subclause 4.5.2.6.5.

- 2) Communication Forwarding No Reply

After receiving the first 180 (Ringing) response the no reply timer (definition see subclause 4.8) shall be started. If forking is provided by the S-CSCF a further received 180 (Ringing) response does not refresh the timer.

When receiving any other final response the no reply timer shall be terminated.

When the no reply timer defined in subclause 4.8 expires:

- The dialog(s) to the diverting user shall be terminated e.g. by sending a CANCEL request or BYE request according to the rules and procedures in IETF RFC 3261 [6], including a Reason header field (see RFC 3326 [24]) with the protocol set to "SIP" and the cause set to "408".
- If the notification procedure of the originating user is supported then the originating user shall be notified as described in the subclause 4.5.2.6.4.
- An INVITE request is sent to the (outgoing) S-CSCF towards the diverted-to user. The INVITE request includes the parameter information as shown in table 4.5.2.6.2.4.
- If the served user has subscribed to the indication of communication diversion to the diverting user, then the served user will be notified of the communication diversion as described in subclause 4.5.2.6.5.

3) Communication Forwarding No Reply (ringing continues)

After receiving the first 180 (Ringing) response the no reply timer (definition see subclause 4.8) shall be started. If forking is provided by the S-CSCF a further received 180 (Ringing) response does not refresh the timer.

When the no reply timer defined in subclause 4.8 expires, an INVITE request is sent to the outgoing S-CSCF towards the diverted to user. The INVITE request includes the parameter information as shown in table 4.5.2.6.2.4.

When the diverting AS receives a provisional response or 200 (OK) response to initial INVITE from diverted-to-user based on operator policy, the dialog(s) to the diverting user shall be terminated e.g. by sending a CANCEL request or a BYE request according to the rules and procedures in IETF RFC 3261 [6], including a Reason header field (see IETF RFC 3326 [24]) with the protocol set to "SIP" and the cause set to "408", and if the notification procedure of the originating user is supported, the originating user shall be notified as described in subclause 4.5.2.6.4.

If the served user has subscribed to the indication of communication diversion to the diverting user, then the served user will be notified of the communication diversion as described in subclause 4.5.2.6.5.

If diverting user accepts the communication after sending the INVITE request the communication path towards the diverted to user shall be released according to the rules and procedures in RFC 3261 [6].

4) Communication Forwarding User Determined Busy

The Communication Forwarding User Determined Busy is offered to the served user when the AS:

- The received 486 (Busy Here) shall be acknowledged with a ACK request.
- If the notification procedures of the originating user is supported then the originating user shall be notified as described in the subclause 4.5.2.6.4.
- An INVITE request containing the diverted-to URI is sent to the outgoing S-CSCF. The INVITE request includes the parameter information as shown in table 4.5.2.6.2.4.

If the served user has subscribed to the indication of communication diversion to the diverting user, then the served user will be notified of the communication diversion as described in subclause 4.5.2.6.5.

5) Communication Deflection immediate response

The Communication Deflection immediate response is offered to the served user.

A 302 (Moved Temporarily) response is received.

If the notification procedures of the originating user is supported then the originating user shall be notified as described in subclause 4.5.2.6.4.

An INVITE request containing the diverted-to URI is sent to the outgoing S-CSCF. The INVITE request includes the parameter information as shown in table 4.5.2.6.2.4.

If the served user has subscribed to the indication of communication diversion to the diverting user, then the served user will be notified of the communication diversion as described in subclause 4.5.2.6.5.

6) Communication Deflection during alerting

When Communication Deflection during alerting is invoked after the AS receives a 180 (Ringing) "Ringing" response, then:

- A 302 (Moved Temporarily) response is received; and
- if the notification procedures of the originating user is supported then the originating user shall be notified as described in subclause 4.5.2.6.4; and
- an INVITE request containing the URI received in the Contact header of the 302 (Moved Temporarily) response as the diverted-to URI shall be sent as specified in 3GPP TS 24.229 [2]. The diverted-to URI could be restricted by setting the privacy header for the entry of the diverted-to URI to "history"; and
- the INVITE request shall include the parameter information as shown in table 4.5.2.6.2.4 "Parameter information for multiple redirection". If the served user has subscribed to the indication of communication diversion to the diverting user, then the served user will be notified of the communication diversion as described in subclause 4.5.2.6.5.

7) Communication Forwarding on Subscriber Not Reachable

When the AS receives a not reachable indication (see subclause 4.5.2.6.6) on the INVITE request forwarded to the served user, then the following criteria shall apply before the Communication Forwarding on Subscriber Not Reachable procedure is executed:

- the served user has an active forwarding rule containing not-reachable condition (see subclause 4.9); and
- the served user is registered.

The following steps shall be followed to perform Communication Forwarding on Subscriber Not Reachable:

- 1) If the notification procedures of the originating user is supported then the originating user shall be notified as described in the subclause 4.5.2.6.4.
- 2) An INVITE request with the Request-URI set to the diverted-to URI is sent to the outgoing S-CSCF. The INVITE request includes the parameter information as shown in table 4.5.2.6.2.4.

If the served user has subscribed to the indication of communication diversion to the diverting user, then the served user will be notified of the communication diversion as described in subclause 4.5.2.6.5.

4.5.2.6.4 Notification procedures of the originating user (Subscription Option)

When Communication Diversion occurs and if served user has the subscription option "*Originating* user receives notification that his communication has been diverted (forwarded or deflected)." set to true then a 181 (Call Is Being Forwarded) response shall be sent towards the originating user.

The following header fields shall be included or modified with the specified values:

- a) The P-Asserted-Identity includes the URI of the diverting user.
- b) The Privacy header with the value "id" shall be included, if:
 - the served user wishes privacy (e.g. the served user is subscribed to the TIR Service); or
 - the served user has the subscription option " Served user allows the presentation of his/her URI to *originating* user in diversion notification." set to false.
- c) The following entries shall be added to the History-Info header field:

- 1) If this is the first diversion then the first entry shall be populated with the hi-targeted-to-uri of the served user. The Index is set to index = 1 according to the rules specified in IETF RFC 4244 [3].
- 2) On the history entry that represents the served user:

the privacy header with value "history" shall be escaped within the hi-targeted-to-uri, if:

- the served user wishes privacy (e.g. the served user is subscribed to the TIR Service); or
- the served user has the subscription option "Served user allows the presentation of his/her URI to *originating* user in diversion notification." set to false.

If the history is already in the escaped form with the correct privacy value no modification is needed.

If the history entry representing the served user contains the "gr" parameter and the served user has the subscription option "Served user allows the presentation of his/her URI to *originating* user in diversion notification" set to "not-reveal-as-GRUU", it shall be changed to the public user identity of the diverting user.

In all other cases the history entry representing the served user shall not be changed.

- 3) A history entry shall be added according to the rules of subclause 4.5.2.6.2.3 item b.2. In addition, for this entry:
 - 1) if the history entry representing the forwarded to URI contains the "gr" parameter and the served user has the subscription option "Served user allows the presentation of forwarded to URI to *originating* user in diversion notification" set to "not-reveal-as-GRUU", it shall be changed to the public user identity of the diverted-to user.
 - 2) the privacy header with value "history" shall be escaped within the hi-targeted-to-uri or the hi-targeted-to-uri shall be set to an anonymous value.

Additionally the AS may initiate an announcement to be included towards the calling user in order to inform about the diversion. Announcements may be played according to procedures as are described in 3GPP TS 24.628 [11].

4.5.2.6.5 Indication of communication diversion to the diverting user (subscription option)

4.5.2.6.5.0 General

If the subscription option "Served user receives indication that a communication has been forwarded (indication of communication diversion to the diverting user)" has been set to "yes", then one or a combination of the following procedures are possible:

- When the diverting user is registering to the communication system, the AS sends a MESSAGE request including the information where his calls are diverted to if any. As an option; the MESSAGE request may be sent to the user after a period of time according to the timer value CDIV Indication Timer as defined in subclause 4.8.3 that can be provided by the user.
- A diverting user will be informed periodically with a MESSAGE request the information where the call is diverted to.

NOTE 1: A diverting user could be informed via a Voicemail or Message mail system in the communication states described above.

- If the subscription option "Served user receives reminder indication on outgoing communication that CDIV is currently activated" has been set to "yes", then a diverting user will be informed with a MESSAGE request after the diverting user has initiated a new outgoing communication. The MESSAGE request includes the information where the call is diverted to.

NOTE 2: A diverting user could be informed via a Voicemail or Message mail system in the communication states described above.

The description of information text contained in the MESSAGE request is out of scope of the present document.

4.5.2.6.5.1 Void

4.5.2.6.5.2 Void

4.5.2.6.6 Not reachable indication

It is recommended that the AS interprets the reception of one of the following response events as not reachable indication:

- 408 (Request timeout) response;
- 503 (Service unavailable) response;
- 500 (Server Internal Error) response;

and no provisional response, different than a 100 (Trying) response, has been received on the same dialog.

NOTE: There may be other means to discover this condition. These other means are out of the scope of the present document.

4.5.2.7 Actions at the AS of the diverted-to user

If the session is diverted, the AS of the diverted-to user shall operate either as an AS acting as a SIP proxy as specified in subclause 5.7.4 of 3GPP TS 24.229 [2] or an AS providing 3rd party call control, and specifically as a routeing B2BUA, as specified in subclause 5.7.5 of 3GPP TS 24.229 [2].

NOTE: For the case when the session is not subject to diversion and CDIV, according the requirements in this document, is the only service being applied by the AS, then the AS only needs to act as a SIP proxy. If additional services are applied, then the AS might need to act as a routeing B2BUA..

The AS shall store the History-Info header of an incoming Request.

If a 180 (Ringing), 181 (Call Is Being Forwarded) or 200 (OK) response does not contain a History-Info header field, the AS shall include the stored History-Info header field. If diverted-to user is subscribed to the TIR service, in the Privacy header field of all responses the priv-value of the last entry in the History-Info header field shall be set to "history".

NOTE: A response including no History-Info header Field is coming from an untrusted entity or the History-Info header field is not included due to the privacy status within the SIP request.

4.5.2.8 Void

4.5.2.9 Void

4.5.2.10 Void

4.5.2.11 Void

4.5.2.12 Void

4.5.2.13 Void

4.5.2.14 Void

4.5.2.15 Actions at the diverted to UA

A UE supporting CDIV services shall support termination of requests in the IM CN subsystem (as specified in 3GPP TS 24.229 [2]).

4.5.2.16 Actions at the diverting UA

A UE supporting CDIV services (e.g. CFU, CFB, CFNR, CD, CFNRc and CFNL) shall support termination of requests in the IM CN subsystem (as specified in 3GPP TS 24.229 [2]). If the UE is intended to support the user subscription option of "indication of communication diversion to the diverting user", this support shall include the receipt of MESSAGE requests (as specified in 3GPP TS 24.229 [2]).

To invoke Communication Deflection the UA shall send a 302 (Moved Temporarily) response to the INVITE request including a Contact header field with the address where the communication is diverted to.

4.6 Interaction with other services

4.6.1 Communication Hold (HOLD)

No impact, i.e. neither service shall affect the operation of the other service.

4.6.2 Terminating Identification Presentation (TIP)

When a communication has been diverted, in order to provide the originating user with information about the diverted-to identity, the diverting AS shall include a SIP or TEL URI of the diverted-to user into a History-Info header field in a 181 (Call Is Being Forwarded) response message and send it to the originating AS, unless the diverting user has selected the option to suppress the notification of diversion. As it is not known what the diverted-to user's TIR settings are, a privacy header field with a priv-value set to "history" needs to be included in escaped form in the hi-entry representing the diverted-to user; or the URI representing the diverted-to user may be set to an anonymous value.

A P-Asserted-Identity and History-Info header field received in the diverting AS is passed unmodified to the originating entity.

NOTE: The originating P-CSCF is responsible for the interpretation of the privacy header field as described in 3GPP TS 24.229 [2].

4.6.3 Terminating Identification Restriction (TIR)

A P-Asserted-Identity and History-Info header field received in the diverting AS is passed unmodified to the originating entity. If TIR applies for the served user, the diverting AS shall add a Privacy header field set to "id" and if a Privacy header field set to "none" is received the diverting AS shall remove it. If a Privacy header field set to "id" is received from the diverted-to user the diverting AS shall pass it unchanged to the originating user.

NOTE: The originating P-CSCF is responsible of the interpretation of the privacy header field as described in 3GPP TS 24.229 [2].

If the served (diverting) user selects the option that the originating user is notified, but without the diverted-to SIP or TEL URI, then the AS shall send a 181 (Call is Being Forwarded) response and either

- escape a Privacy header field with a priv-value set to "history" in the hi-entry representing the diverted-to user; or
- anonymize the hi-entry representing the diverted-to user.

4.6.4 Originating Identification Presentation (OIP)

When a communication has been diverted and the diverted-to user has been provided with the OIP service, normal procedures apply in the IMS network serving the diverted-to user. The diverting AS shall pass all received privacy headers unmodified. The diverting AS shall add the identity of the diverting user in the History-Info header field with an embedded Privacy header reflecting the served users privacy settings.

4.6.5 Originating Identification Restriction (OIR)

When the OIR service has been invoked, normal procedures apply in the IMS network serving the diverted-to user. The diverting AS shall pass all received privacy headers unmodified. The diverting AS shall add the identity of the diverting user in the History-Info header field with an embedded Privacy header reflecting the served users privacy settings.

NOTE: The P-CSCF executes the related privacy procedures as described in 3GPP TS 24.229 [2].

4.6.6 Conference calling (CONF)

No impact, i.e. neither service shall affect the operation of the other service.

4.6.7 Communication Diversion Services (CDIV)

CFU, CFNL, and CFB when NDUB is used are all determined immediately when an INVITE request is received, and take precedence over CDIV services that are based on a response (CD, CFNRc, CFNR, and CFB when UDUB is used). CFU take precedence over all other CDIV services and the CDIV AS must evaluate the rule associated with CFU before CFNL and CFB when NDUB is used. As CFNL and CFB cannot occur simultaneously there is no interaction. For CDIV services that are based on a response, the response received first will invoke the associated CDIV service.

For the indication of communication diversion to the diverting user service, the provision and activation of at least one redirection service is a pre-requirement to provision and activate the indication of communication diversion to the diverting user service

4.6.8 Malicious Communication Identification (MCID)

No impact, i.e. neither service shall affect the operation of the other service.

4.6.9 Anonymous Communication Rejection and Communication Barring (ACR/CB)

If the user where the communication is forwarded to has subscribed to a call barring service "inhibition of incoming forwarded communication" the procedures described in 3GPP TS 24.611 [9] shall take precedence.

If the OCB service has already been activated, the CDIV AS shall reject a request to activate any CDIV service if the forwarding party's communication to the diverted-to party would be barred by the OCB service.

If the CDIV service was activated before the activation of the OCB service, the OCB service can still be activated. When the two services have already been activated, the CDIV AS shall not invoke the CDIV service if the forwarding party's communication to the diverted-to party would be barred by the OCB service at the time of the invocation attempt of the CDIV service.

4.6.10 Explicit Communication Transfer (ECT)

4.6.10.1 Actions at the diverting AS

4.6.10.1.1 Determine whether ECT is applied to the diverted communication

See 3GPP TS 24.629 [16] on the criteria that determine that a REFER request is to be treated as a request for transfer of an existing communication.

4.6.10.1.2 Handling of transfer requests

When a REFER request is received towards the originating user in the context of a call transfer scenario (see subclause 4.6.10.1.1), the diverting AS shall perform the following steps:

- 1) Create a new CDIV Session Identifier URI addressed to this AS. The URI shall be created in such a way that a new dialog set up towards this URI can be easily correlated with the current REFER dialog.

- 2) The AS stores the value of the Refer-To header field (transfer target) from the REFER request and links it to the CDIV Session Identifier URI.
- 3) The AS Replaces the Refer-To header field with the CDIV Session Identifier URI. (This ensures that the diverting AS remains in the loop when the transferee sets up the communication with the transfer target.).
- 4) The AS forwards the REFER request to the transferee using basic communication procedures 3GPP TS 24.229 [2].

A REFER request received towards the diverted-to user is forwarded using normal procedures.

4.6.10.1.3 Actions when CDIV is invoked again by the transferred communication

When an INVITE request is received targeted at the CDIV Session Identifier URI created earlier when transfer of the diverted ongoing communication was requested, the AS shall perform the following actions:

- 1) The AS replaces the request URI with the stored Refer-To header field value linked to the specific CDIV Session Identifier URI.

NOTE: If needed the AS may generate charging events to charge for the extra leg.

- 2) Void.
- 3) The AS forwards the INVITE request towards the transfer target using basic communication procedures 3GPP TS 24.229 [2].

4.6.11 Communication Waiting (CW)

Communication Forwarding Unconditional (CFU): CW has no impact on CFU. The communication will be forwarded without regard to the terminating party's state. The CFU service can be activated while a call is waiting without changing the state of the waiting call. A forwarded communication can result in the communication waiting service.

Communication Forwarding Busy (CFB): No impact, i.e. neither service affects the operation of the other service. A forwarded communication can result in the communication waiting service.

NOTE: If the terminating party is NDUB, the CW service will not be invoked, and the CFB service is invoked if it was activated.

Communication Forwarding No Reply (CFNR): If the terminating party has activated the CFNR service, then the CW AS still shall offer a waiting communication. If the CFNR timer expires before an answer is received then the CFNR service shall be invoked and the CDIV AS shall forward the communication. The CDIV AS cancels the communication to the served user. A forwarded communication can result in the communication waiting service.

Communication Forwarding on Not Logged-in (CFNL): No impact, i.e. neither service affects the operation of the other service.

NOTE: If a party with an active communication waiting logs out, all active and offered communications would be released.

Communication Deflection (CD): When receiving the communication waiting indication, terminating party can invoke the CD service. A deflected communication can result in the communication waiting service.

Communication Forwarding on Subscriber Not Reachable (CFNRc): No impact, i.e. neither service affects the operation of the other service.

4.6.12 Completion of Communications to Busy Subscriber (CCBS)

The CC AS shall not divert a CC recall. It shall provide the CC recall to the original originating party.

4.6.13 Advice Of Charge (AOC)

No impact, i.e. neither service affects the operation of the other service.

4.7 Interworking with other networks

4.7.1 Void

4.7.2 Void

4.7.3 Void

4.8 Parameter values (timers)

4.8.1 No reply timer

No reply timer: Timer duration shall be a service provider option.

4.8.2 Void

4.8.3 CDIV Indication Timer

CDIV Indication Timer: 60 sec to 00 sec.

The timer is started when the diverting user is registering to the communication system. Based on operator policy the user has the possibility to choose a certain timer value within the defined range.

4.9 Service Configuration for redirection services

4.9.1 Structure of the XML Document

4.9.1.0 General

Communication Diversion documents are subtrees of the *simservs* document specified in 3GPP TS 24.623 [4]. As such, Communication Diversion documents use the XCAP application usage in 3GPP TS 24.623 [4].

In addition to the considerations and constraints defined by the *simservs* document 3GPP TS 24.623 [4], we define the additional constraints and considerations for the Communication Diversion subtree:

XML schema: Implementations in compliance with the present document shall implement the XML schema that minimally includes the XML Schema defined in subclause 4.9.2 and the *simservs* XML schema specified in 3GPP TS 24.623 [4].

Data semantics: The semantics of the communication diversion XML configuration document is specified in subclause 4.9.1.

An instance of the supplementary services configuration containing a communication diversion configuration document.

```
<?xml version="1.0" encoding="UTF-8"?>
<simservs
xmlns="http://uri.etsi.org/ngn/params/xml/simservs/xcap"
xmlns:cp="urn:ietf:params:xml:ns:common-policy"
xmlns:ocp="urn:oma:xml:xdm:common-policy">
  <communication-diversion active="true">
    rule set
  </communication-diversion>
</simservs>
```

The communication diversion service contains a rule set that specifies how the communication diversion service shall react to external stimuli.

4.9.1.1 Communication Diversion Element

The communication diversion configuration contains a noReplyTimer element, a rule set, or a noReplyTimer element followed by a rule set.

The rule set reuses the syntax as specified by the common policy draft (see RFC 4745 [18]).

```
<communication-diversion active="true">
  <NoReplyTimer>NoReplyTimerValue</NoReplyTimer>
  <cp:ruleset>
    rule1
    rule2
  </cp:ruleset>
</communication-diversion>
```

In general the following procedure applies:

When the service processes a set of rules it shall start executing the first rule. If:

- the rule has no <conditions> element;
- the rule has an empty <conditions> element; or
- conditions are present and they all evaluate to true;

then the rule matches and the specified action shall be executed.

When the rule does not match the following rule shall be selected and the same procedure repeated, until a matching rule is found or the set of remaining rules is empty.

However not all rules can be matched at the same moment in the call. Some conditions imply that rules that carry them are checked at specific events in the call, for example the no-answer condition only holds when the called party does not answer after a while. In this case the same procedure shall apply as above with the modification that the set of rules to process contains only the rules applicable for that specific network event.

In subclause 4.9.1.3 all allowed conditions are specified, normally rules are evaluated at communication setup time, for conditions where this is not the case this is explicitly indicated.

The shown "active" attribute is inherited from the simservType from 3GPP TS 24.623 [4], its meaning is also specified in 3GPP TS 24.623 [4].

4.9.1.1A NoReplyTimer

NoReplyTimer: An optional element that covers the time to elapse until the communication diversion shall perform, if the served user does not answer when alerted.

4.9.1.2 Communication Diversion Rules

The Communication Diversion service is configured with an ordered set of forwarding rules. The XML Schema reuses the rule syntax as specified by the common policy draft (see IETF RFC 4745 [18]). The rules take the following form:

```
<cp:rule id="rule66">
  <cp:conditions>
    condition1
    condition2
  </cp:conditions>
  <cp:actions>
    <forward-to>
      <target>
        targetAddress1
      </target>
      <notify-caller>true</notify-caller>
    </forward-to>
  </cp:actions>
```

```
</cp:rule>
```

To give more guidance, an example of such a rule is shown below:

```
<cp:rule id="rule66">
  <cp:conditions>
    <ss:busy/>
    <ss:media>PCMA</ss:media>
    <cp:identity>
      <cp:one>id=serveduser@domain</cp:one>
    </cp:identity>
  </cp:conditions>
  <cp:actions>
    <forward-to>
      <target>
        targetAddress1
      </target>
      <notify-caller>true</notify-caller>
    </forward-to>
  </cp:actions>
</cp:rule>
```

When the service processes a set of rules it shall start executing the first rule. If:

- the rule has no <conditions> element;
- the rule has an empty <conditions> element; or
- conditions are present and they all evaluate to true;

then the rule matches and the specified action is executed. When a rule matches remaining rules in the rule set shall be discarded. Applied to the fragment above this means that only if the expression (*condition1* AND *condition2*) evaluates to true that then the *rule66* matches and the forward-to action is executed.

When the rule does not match the following rule shall be selected and the same procedure repeated, until a matching rule is found or the set of remaining rules is empty.

The "id" attribute value of a rule shall uniquely identify the rule within a rule set. This can be used in XCAP usage to address one specific rule.

4.9.1.3 Communication Diversion Rule Conditions

The following conditions are allowed by the XML Schema for the communication diversion service:

busy: This condition evaluates to true when the called user is busy. In all other cases the condition evaluates to false. Rules with this condition are evaluated when a busy indication is received. Receipt of a SIP 486 (Busy Here) response is a busy indication.

not-registered: This condition evaluates to true when the called user is not registered. In all other cases the condition evaluates to false.

presence-status: This condition evaluates to true when the called user's current presence activity status is equal to the value set for this condition. In all other cases the condition evaluates to false.

cp:identity: This condition evaluates to true when the *calling* user's identity matches with the value of the identity element. The interpretation of all the elements of this condition is described in OMA-TS-XDM-Core-V1_1 [21]. In all other cases the condition evaluates to false. The Identity shall be matched against the value taken from the P-Asserted-Identity header field, and in addition as an option matched against the From header field and/or the Referred-By header field, unless both the <identity> element value and the Contact header field value contain a "gr" parameter, then the <identity> element value shall be matched against the value taken from the Contact header field.

anonymous: This condition evaluates to true when the P-Asserted-Identity of the calling user is not provided or privacy restricted.

cp:sphere: Not applicable in the context of the Communication Diversion service.

cp:validity: Specifies a period. The condition evaluates to true when the current time is within the validity period expressed by the value of this condition. In all other cases the condition evaluates to false.

media: When the incoming call request for certain media, the forwarding rule can decide to forward the call for this specific media. This condition evaluates to true when the value of this condition matches the media field in one of the "m=" lines in the SDP (IETF RFC 4566 [5]) offered in an INVITE request (IETF RFC 3261 [6]).

no-answer: This condition evaluates to true when the called user does not answer. In all other cases the condition evaluates to false. Rules with this condition are evaluated when a no-answer timeout is detected or when a no answer indication is received..

rule-deactivated: This condition always evaluates to false. This can be used to deactivate a rule, without losing information. By removing this condition the rule can be activated again.

ocp:external-list: This condition evaluates to true when the calling user's identity is contained in an external resource list to which the value of external-list refers. The exact interpretation of this element is specified in OMA-TS-XDM-Core-V1_1 [21].

ocp:other-identity: Not applicable in the context of communication diversion service.

not-reachable: This condition evaluates to true when there is a signalling channel outage during session setup to the served user's UE and the served user is registered. Receipt of a 500 (Server Internal Error) response is an indication that the served user's UE is unreachable. In all other cases this condition evaluates to false.

NOTE: As described in IETF RFC 4745 [18] the case of unconditional evaluates to be true in all cases where all other reasons are not applicable. A communication diversion is performed as soon as the served user is the called user. The indication of unconditional is the absence of any reason element in the ss:condition element.

The condition elements that are not taken from the common policy schema (see IETF RFC 4745 [18]) or oma common policy schema (see OMA-TS-XDM-Core-V1_1 [21]) are defined in the sirmservs document schema specified in 3GPP TS 24.623 [4].

Information of which of the above mentioned conditions the user is allowed to use can be obtained from the network by using the schema defined in subclause 4.9.3.

The "serv-cap-media" element lists the elements that can be used in the "media" rule condition.

4.9.1.4 Communication Diversion Rule Actions

The action supported by the CDIV service is forwarding of calls. For this the forward-to action has been defined. The forward-to action takes the following elements:

target: Specifies the address of the forwarding rule. It should be a SIP URI (IETF RFC 3261 [6]) or TEL URL (IETF RFC 3966 [6]).

notify-caller: An optional element that can be used to disable the default behaviour that the caller is notified that the call is being forwarded. (see subscription option "*Originating* user receives notification that his communication has been diverted (forwarded or deflected)" in table 4.3.1.1)

reveal-served-user-identity-to-caller: An optional element that can be used to disable the default behaviour that the caller, when notified that the call is being forwarded, receives the *diverting* party's identity information. (see subscription option "Served user allows the presentation of his/her URI to *originating* user in diversion notification" in table 4.3.1.1)

reveal-identity-to-caller: An optional element that can be used to disable the default behaviour that the caller, when notified that the call is being forwarded, receives some diverted-to party's identity information. (see subscription option "Served user allows the presentation of diverted to URI to *originating* user in diversion notification" in table 4.3.1.1)

notify-served-user: An optional element that can be used to enable that the served user is indicated that calls are being forwarded. Default this is switched off. (see subscription option "*Served user* receives indication that a communication has been forwarded (indication of communication diversion to the diverting user)" in table 4.3.1.1)

notify-served-user-on-outbound-call: An optional element that can be used to enable that the served user is notified that calls are being forwarded when he makes a call attempt. Default this is switched off. (see subscription option "Served user receives reminder indication on outgoing communication that CDIV is currently activated" in table 4.3.1.1)

reveal-identity-to-target: An optional element that can be used to disable the default behaviour that the diverted-to party receives some identity information of the diverting party. (see subscription option "Served user allows the presentation of his/her URI to *diverted-to* user" in table 4.3.1.1)

Information of which of the above mentioned actions the user is allowed to use can be obtained from the network by using the schema defined in subclause 4.9.3. The 'serv-cap-target' element indicates whether the user is allowed to use any URI as target or whether the target needs to correspond to a telephone number, i.e. a SIP URI with a "user" URI parameter set to "phone" or a tel URI.

4.9.1.5 Supported Actions and Conditions for Communication Diversion

The supported actions and conditions for communication diversion are configured with a list of action capability and condition capability elements. These capability elements are read only and indicate which capabilities related to communication diversion the network has provisioned for a user.

EXAMPLE: An instance of the simulation services configuration containing a service capabilities document for communication diversion is shown in the following example. It is based on operator policy if the restriction of <serv-cap-target> element to <telephony-type> is needed. In this example, the same capabilities as in call diversion in a CS network are supported.

```
<?xml version="1.0" encoding="UTF-8"?>
<simservs
xmlns="http://uri.etsi.org/ngn/params/xml/simservs/xcap">
  <communication-diversion-serv-cap active="true">
    <serv-cap-conditions>
      <serv-cap-external-list provisioned="false"></serv-cap-external-list>
      <serv-cap-identity provisioned="false"></serv-cap-identity>
      <serv-cap-media>
        <media>audio</media>
        <media>video</media>
      </serv-cap-media>
      <serv-cap-presence-status provisioned="false"></serv-cap-presence-status>
      <serv-cap-validity provisioned="false"></serv-cap-validity>
    </serv-cap-conditions>
    <serv-cap-actions>
      <serv-cap-target>
        <telephony-type/>
      </serv-cap-target>
      <serv-cap-notify-served-user-on-outbound-call provisioned="false">
        </serv-cap-notify-served-user-on-outbound-call>
      <serv-cap-reveal-identity-to-caller provisioned="false">
        </serv-cap-reveal-identity-to-caller>
      <serv-cap-reveal-served-user-identity-to-caller provisioned="false">
        </serv-cap-reveal-served-user-identity-to-caller>
      <serv-cap-reveal-identity-to-target provisioned="false">
        </serv-cap-reveal-identity-to-target>
      </serv-cap-actions>
    </communication-diversion-serv-cap>
  </simservs>
```

4.9.2 XML Schema

```
<?xml version="1.0" encoding="UTF-8"?>
<xs:schema xmlns:xs="http://www.w3.org/2001/XMLSchema"——
xmlns:ss="http://uri.etsi.org/ngn/params/xml/simservs/xcap"
xmlns:cp="urn:ietf:params:xml:ns:common-policy"
xmlns:ocp="urn:oma:xml:xm:common-policy"
targetNamespace="http://uri.etsi.org/ngn/params/xml/simservs/xcap"
elementFormDefault="qualified"
attributeFormDefault="unqualified">
  <!-- import common policy definitions -->
  <xs:import namespace="urn:ietf:params:xml:ns:common-policy" schemaLocation="common-policy.xsd"/>
  <!-- import OMA common policy extensions -->
  <xs:import namespace="urn:oma:xml:xm:common-policy" schemaLocation="OMA-SUP-
XSD_xdm_commonPolicy-V1_0_2-20070830-A.xsd"/>
```



```

<!-- communication diversion specific extensions to IETF common policy conditions. The
cp:conditionsType is expanded with the elements: ss:not-registered, ss:busy, ss:no-answer, ss:not-
reachable, ss:media as optional elements -->
<!-- communication diversion rule set based on the common policy rule set.-->
<xs:element name="communication-diversion" substitutionGroup="ss:absService">
  <xs:annotation>
    <xs:documentation>This is the communication diversion configuration
document.</xs:documentation>
  </xs:annotation>
  <xs:complexType>
    <xs:complexContent>
      <xs:extension base="ss:simservType">
        <xs:sequence>
          <!-- add service specific elements here-->
          <xs:element ref="ss:NoReplyTimer" minOccurs="0"/>
          <xs:element ref="cp:ruleset" minOccurs="0"/>
        </xs:sequence>
      </xs:extension>
      <!-- service specific attributes can be defined here -->
    </xs:complexContent>
  </xs:complexType>
</xs:element>

<!-- communication diversion specific extensions to IETF common policy actions-->
<xs:element name="forward-to" type="ss:forward-to-type"/>
<xs:simpleType name="reveal-URI-options-type">
  <xs:restriction base="xs:string">
    <xs:enumeration value="false"/>
    <xs:enumeration value="not-reveal-GRUU"/>
    <xs:enumeration value="true"/>
  </xs:restriction>
</xs:simpleType>
<!-- communication diversion specific type declarations -->
<xs:complexType name="forward-to-type">
  <xs:sequence>
    <xs:element name="target" type="xs:anyURI" minOccurs="1" maxOccurs="1"/>
    <xs:element name="notify-caller" type="xs:boolean" default="true" minOccurs="0"/>
    <xs:element name="reveal-identity-to-caller" type="ss:reveal-URI-options-type"
default="true" minOccurs="0"/>
    <xs:element name="reveal-served-user-identity-to-caller" type="ss:reveal-URI-options-
type" default="true" minOccurs="0"/>
    <xs:element name="notify-served-user" type="xs:boolean" default="false" minOccurs="0"/>
    <xs:element name="notify-served-user-on-outbound-call" type="xs:boolean" default="false"
minOccurs="0"/>
    <xs:element name="reveal-identity-to-target" type="ss:reveal-URI-options-type"
default="true" minOccurs="0"/>
  </xs:sequence>
</xs:complexType>
<xs:element name="NoReplyTimer">
  <xs:simpleType>
    <xs:restriction base="xs:positiveInteger">
      <xs:minInclusive value="5"/>
      <xs:maxInclusive value="180"/>
    </xs:restriction>
  </xs:simpleType>
</xs:element>
</xs:schema>

```

4.9.3 XML schema for indication of supported conditions and actions

```

?xml version="1.0" encoding="UTF-8"?>
<xs:schema xmlns:xs="http://www.w3.org/2001/XMLSchema"
xmlns:ss="http://uri.etsi.org/ngn/params/xml/simservs/xcap"
targetNamespace="http://uri.etsi.org/ngn/params/xml/simservs/xcap" elementFormDefault="qualified"
attributeFormDefault="unqualified">
  <xs:annotation>
    <xs:documentation xml:lang="en">
      This schema defines elements that are used to inform the UE which conditions and actions the
network support.
    </xs:documentation>
  </xs:annotation>
  <xs:include schemaLocation="XCAP.xsd"/>
  <xs:element name="communication-diversion-serv-cap" substitutionGroup="ss:absService">
    <xs:complexType>
      <xs:complexContent>
        <xs:extension base="ss:simservType">
          <xs:sequence>

```

```

<xs:element name="serv-cap-conditions" minOccurs="0">
  <xs:complexType>
    <xs:sequence>
      <xs:element name="serv-cap-anonymous" type="ss:provisioned-type"
        minOccurs="0"/>
      <xs:element name="serv-cap-busy" type="ss:provisioned-type"
        minOccurs="0"/>
      <xs:element name="serv-cap-external-list" type="ss:provisioned-type"
        minOccurs="0"/>
      <xs:element name="serv-cap-identity" type="ss:provisioned-type"
        minOccurs="0"/>
      <xs:element name="serv-cap-media" type="ss:supported-media-type"
        minOccurs="0"/>
      <xs:element name="serv-cap-not-registered" type="ss:provisioned-type"
        minOccurs="0"/>
      <xs:element name="serv-cap-no-answer" type="ss:provisioned-type"
        minOccurs="0"/>
      <xs:element name="serv-cap-not-reachable" type="ss:provisioned-type"
        minOccurs="0"/>
      <xs:element name="serv-cap-presence-status" type="ss:provisioned-type"
        minOccurs="0"/>
      <xs:element name="serv-cap-rule-deactivated" type="ss:provisioned-type"
        minOccurs="0"/>
      <xs:element name="serv-cap-validity" type="ss:provisioned-type"
        minOccurs="0"/>
    </xs:sequence>
  </xs:complexType>
</xs:element>
<xs:element name="serv-cap-actions" minOccurs="0">
  <xs:complexType>
    <xs:sequence>
      <xs:element name="serv-cap-target" type="ss:provisioned-target-type"
        minOccurs="0"/>
      <xs:element name="serv-cap-notify-caller" type="ss:provisioned-type"
        minOccurs="0"/>
      <xs:element name="serv-cap-notify-served-user" type="ss:provisioned-type"
        minOccurs="0"/>
      <xs:element name="serv-cap-notify-served-user-on-outbound-call"
        type="ss:provisioned-type" minOccurs="0"/>
      <xs:element name="serv-cap-reveal-identity-to-caller"
        type="ss:provisioned-type" minOccurs="0"/>
      <xs:element name="serv-cap-reveal-served-user-identity-to-caller"
        type="ss:provisioned-type" minOccurs="0"/>
      <xs:element name="serv-cap-reveal-identity-to-target"
        type="ss:provisioned-type" minOccurs="0"/>
    </xs:sequence>
  </xs:complexType>
</xs:element>
</xs:sequence>
</xs:extension>
</xs:complexContent>
</xs:complexType>
</xs:element>
</xs:schema>

```

4.10 Void

Annex A (informative): Signalling Flows

A.1 Normal cases

A.1.1 Communication Forwarding unconditional

Figure A.1 shows an example signalling flow for a successful communication forwarding unconditional based on an AS providing the forwarding.

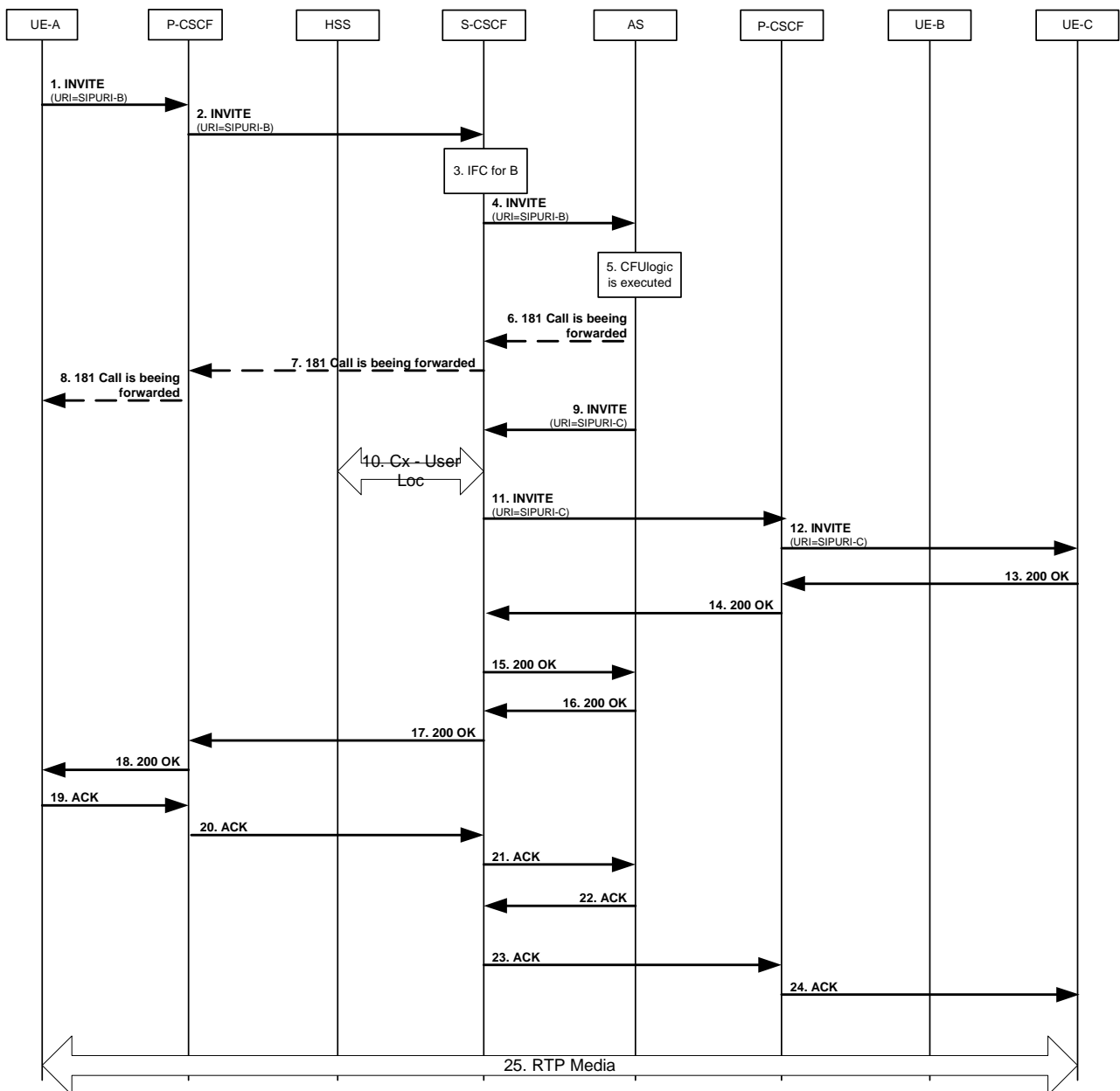

Figure A.1: CFU AS based normal case

User B has activated the CFU service.

User A is sending a communication request towards User B:

- 1)Initial INVITE request towards User B. - see example in table A.1.1-1.

Table A.1.1-1: INVITE request (UE A to P-CSCF)

```

INVITE sip:user2_public1@home1.net;gr=2ad8950e-48a5-4a74-8d99-ad76cc7fc74c SIP/2.0
Via: SIP/2.0/UDP [5555::aaa:bbb:ccc:ddd]:1357;comp=sigcomp;branch=z9hG4bKnashds7
Max-Forwards: 70
Route: <sip:pcscf1.visited1.net:7531;lr;comp=sigcomp>, <sip:scscf1.home1.net;lr>
P-Preferred-Identity: "John Doe" <sip:user1_public1@home1.net>
P-Access-Network-Info: 3GPP-UTRAN-TDD; utran-cell-id-3gpp=234151D0FCE11
Privacy: none
From: <sip:user1_public1@home1.net>;tag=171828
To: sip:user2_public1@home1.net;gr=2ad8950e-48a5-4a74-8d99-ad76cc7fc74c
Call-ID: cb03a0s09a2sdfgklkj490333
Cseq: 127 INVITE
Require: sec-agree
Proxy-Require: sec-agree
Supported: precondition, 100rel, gruu, 199
Security-Verify: ipsec-3gpp; q=0.1; alg= hmac-sha-1-96; spi-c=98765432; spi-s=87654321; port-c=8642;
port-s=7531
Contact: <sip:user1_public1@home1.net;gr=urn:uuid:f81d4fae-7dec-11d0-a765-
00a0c91e6bf6;comp=sigcomp>;+g.3gpp.icsi - ref="urn:3Aurn-7%3gpp-service.ims.icsi.mmtel"
Allow: INVITE, ACK, CANCEL, BYE, PRACK, UPDATE, REFER, MESSAGE
Accept: application/sdp,application/3gpp-ims+xml
Accept-Contact: *;+g.3gpp.icsi - ref="urn:3Aurn-7%3gpp-service.ims.icsi.mmtel"
P-Preferred-Service: urn:urn-7:3gpp-service.ims.icsi.mmtel
Content-Type: application/sdp
Content-Length: (...)

v=0
o=- 2987933615 2987933615 IN IP6 5555::aaa:bbb:ccc:ddd
s=-
c=IN IP6 5555::aaa:bbb:ccc:ddd
t=0 0
m=video 3400 RTP/AVP 98 99
a=tcap:1 RTP/AVPF
a=pcfg:1 t=1
b=AS:75
a=curr:qos local none
a=curr:qos remote none
a=des:qos mandatory local sendrecv
a=des:qos none remote sendrecv
a=inactive
a=rtpmap:98 H263
a=fmtp:98 profile-level-id=0
a=rtpmap:99 MP4V-ES
m=audio 3456 RTP/AVP 97 96
a=tcap:1 RTP/AVPF
a=pcfg:1 t=1
b=AS:25.4
a=curr:qos local none
a=curr:qos remote none
a=des:qos mandatory local sendrecv
a=des:qos none remote sendrecv
a=inactive
a=rtpmap:97 AMR
a=fmtp:97 mode-set=0,2,5,7; maxframes=2
a=rtpmap:96 telephone-event

```

- 2) Initial INVITE request towards User B. The URI-B is subscribed to the CFU service.

3 to 4) Using the IFC the INVITE is forwarded to the AS.

- 5) Procedures for CFU are executed.

6 to 8) Depending on the value of subscription option '*Originating* user receives notification that his communication has been diverted (forwarded or deflected)', a 181 (Call Is Being Forwarded) response is sent towards the User A indicating that the communication is diverted.

- 9) An INVITE request including URI-C as destination is sent back to the S-CSCF. Additional the History-Info header is included. - see example in table A.1.1-9.

Table A.1.1-9: INVITE request (AS to S-CSCF)

```

INVITE sip:User-C@example.com;cause=302 SIP/2.0
Via: SIP/2.0/UDP as.home1.net;branch=z9hG4bK712z34.1,
SIP/2.0/UDP scscf1.home1.net;branch=z9hG4bK332b23.1,
SIP/2.0/UDP pcscf1.home1.net;branch=z9hG4bK240f34.1,
SIP/2.0/UDP [5555::aaa:bbb:ccc:ddd]:1357;comp=sigcomp;branch=z9hG4bKnashds7
Max-Forwards: 67
Record-Route: <sip:as.home1.net>, <sip:scscf1.home1.net;lr>,<sip:pcscf1.home1.net;lr>
Route: <sip:scscf1.home1.net;lr>
P-Asserted-Identity: "John Doe" <sip:user1_public1@home1.net>
Privacy:
From: <sip:user1_public1@home1.net>;tag=171828
To: sip:user2_public1@home1.net;gr=2ad8950e-48a5-4a74-8d99-ad76cc7fc74c
Call-ID:
Cseq:
Require:
Proxy-Require:
Supported:
Security-Verify:
Contact:
Allow:
Accept:
Accept-Contact:
P-Asserted-Service: urn:urn-7:3gpp-service.ims.icsi.mmtel
History-Info: <sip:user2_public1@home1.net;gr=2ad8950e-48a5-4a74-8d99-ad76cc7fc74c;
>index=1,<sip:User-C@example.com;cause=302>index=1.1
Content-Type:
Content-Length:

v=
o=
s=
c=
t=
m=
a=
a=
b=
a=
a=
a=
a=
a=
a=
a=
a=
a=
a=
a=
a=
a=
m=
a=
a=
b=
a=
a=
a=
a=
a=
a=
a=
a=
a=
a=
a=
a=
a=
a=
a=
a=

```

- 10) S-CSCF looks up to the HSS to identify the location of User-C.
- 11 to 12) The communication is routed towards User-C.
- 13 to 18) The 200 (OK) response is sent back to the User-A.
- 19 to 24) The ACK request is sent back to User-B.
- 25) RTP media is established.

A.1.2 Communication Deflection

Figures A.2a and A.2b describe the Immediate CD feature the only difference compared to a regular CD is that in the regular CD case the "302 (Moved Temporarily) Moved Temporarily" is preceded by a "180 (Ringing) Ringing".

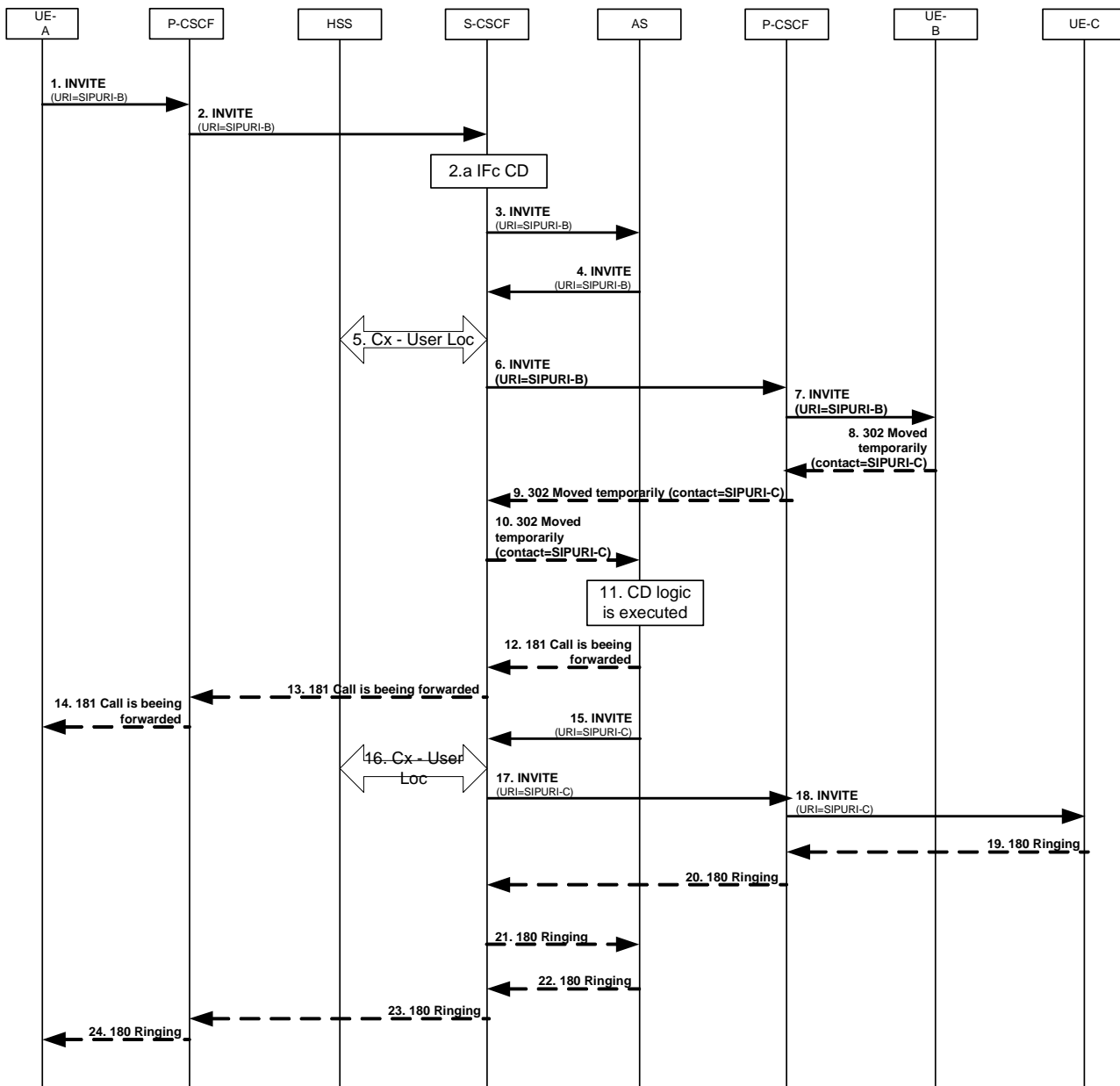

Figure A.2a

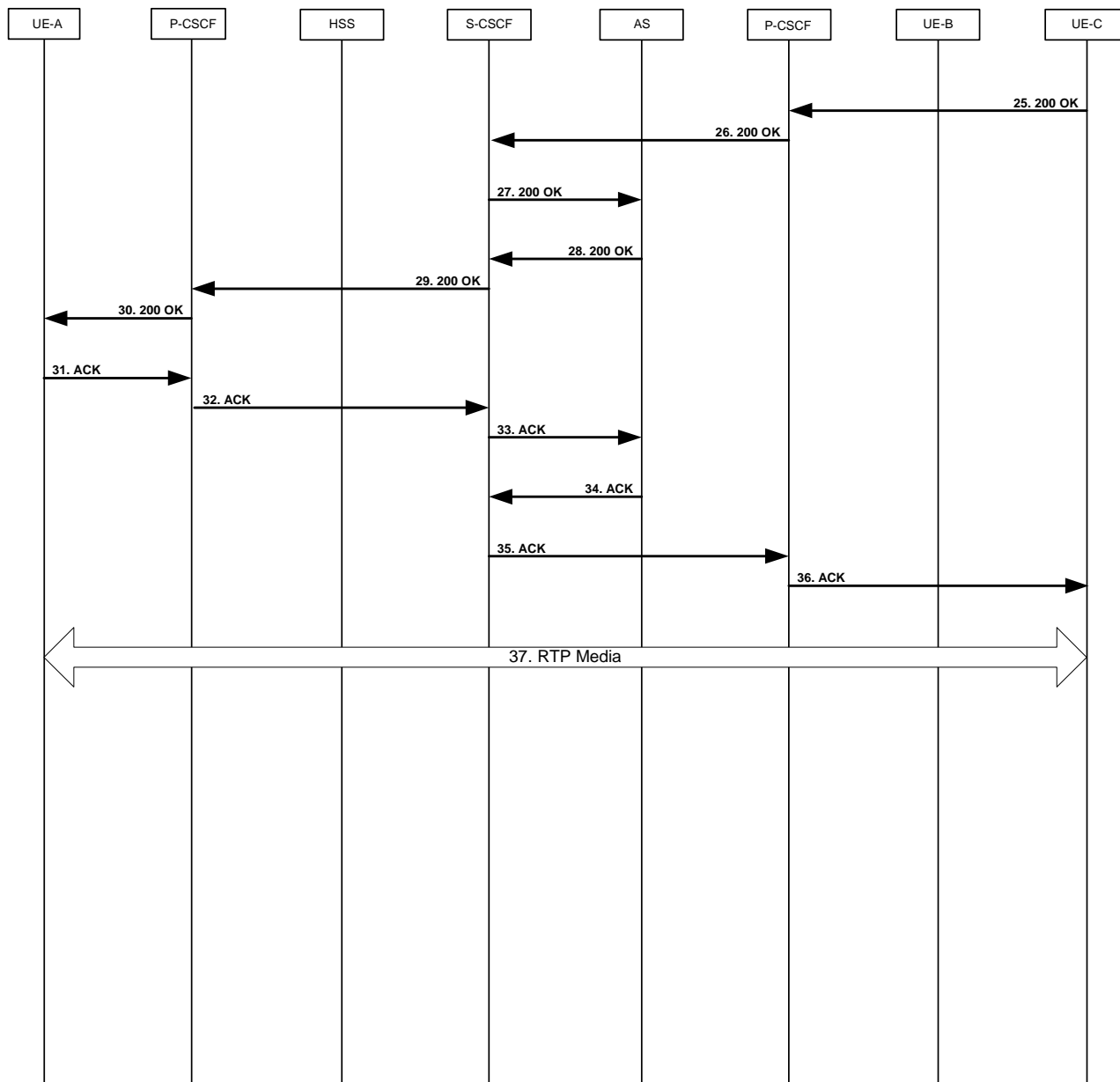

Figure A.2b

User B has activated the CD service.

User A is sending a communication request towards User B:

1 to 2) Initial INVITE request towards User B. The URI-B is subscribed to the CFU service. - see example in table A.1.1-1

2a to 3) Using IFC the INVITE request is forwarded to the AS.

4 to 7) The INVITE request is forwarded to User B due to normal communication procedures.

8 to 10) A 302 (Moved Temporarily) response with a contact header including the URI of the forwarded to user is sent back to the AS.

11)The CD logic is executed.

12 to 14) Depending on the value of subscription option '*Originating* user receives notification that his communication has been diverted (forwarded or deflected)', a 181 (Call Is Being Forwarded) response is sent towards the User A indicating that the communication is diverted.

- 15) An INVITE request including URI-C as destination is sent back to the S-CSCF. Additional the History-Info header is included. - see example in table A.1.2-15.

Table A.1.2-15: INVITE request (AS to S-CSCF)

```

INVITE sip:User-C@example.com;cause=480 SIP/2.0
Via: SIP/2.0/UDP as.home1.net;branch=z9hG4bK712z34.1,
SIP/2.0/UDP scscf1.home1.net;branch=z9hG4bK332b23.1,
SIP/2.0/UDP pcscf1.home1.net;branch=z9hG4bK240f34.1,
SIP/2.0/UDP [5555::aaa:bbb:ccc:ddd]:1357;comp=sigcomp;branch=z9hG4bKnashds7
Max-Forwards: 67
Record-Route: <sip:as.home1.net>, <sip:scscf1.home1.net;lr>, <sip:pcscf1.home1.net;lr>
Route: <sip:scscf1.home1.net;lr>
P-Asserted-Identity: "John Doe" <sip:user1_public1@home1.net>
P-Access-Network-Info:
Privacy:
From: <sip:user1_public1@home1.net>;tag=171828
To: sip:user2_public1@home1.net;gr=2ad8950e-48a5-4a74-8d99-ad76cc7fc74c
Call-ID:
Cseq:
Require:
Proxy-Require:
Supported:
Security-Verify:
Contact:
Allow:
Accept:
Accept-Contact:
P-Asserted-Service: urn:urn-7:3gpp-service.ims.icsi.mmtel
History-Info: <sip:user2_public1@home1.net;gr=2ad8950e-48a5-4a74-8d99-
ad76cc7fc74c?Reason=sip%3Bcause=302>index=1, <sip:User-C@example.com;cause=480>index=2
Content-Type:
Content-Length:

v=
o=
s=
c=
t=
m=
a=
a=
b=
a=
a=
a=
a=
a=
a=
a=
a=
m=
a=
a=
b=
a=
a=
a=
a=
a=
a=
a=
a=
a=
a=
a=

```

- 16 to 18) An INVITE request including URI-C as destination is routed to UE C.

- 19 to 24) A 180 (Ringing) response is sent back to the originating user including a History-Info header as shown above. If no restriction is given the diverted to user will be presented at the UE of user A.

- 25 to 30) The 200 (OK) response is sent back to the User-A.

- 31 to 36) The ACK request is sent back to User-B.

- 37) RTP media is established.

A.1.3 Communication forwarding on no reply

Figures A.3a and A.3b shows an example signalling flow for a successful communication forwarding on no reply based on an AS providing the forwarding.

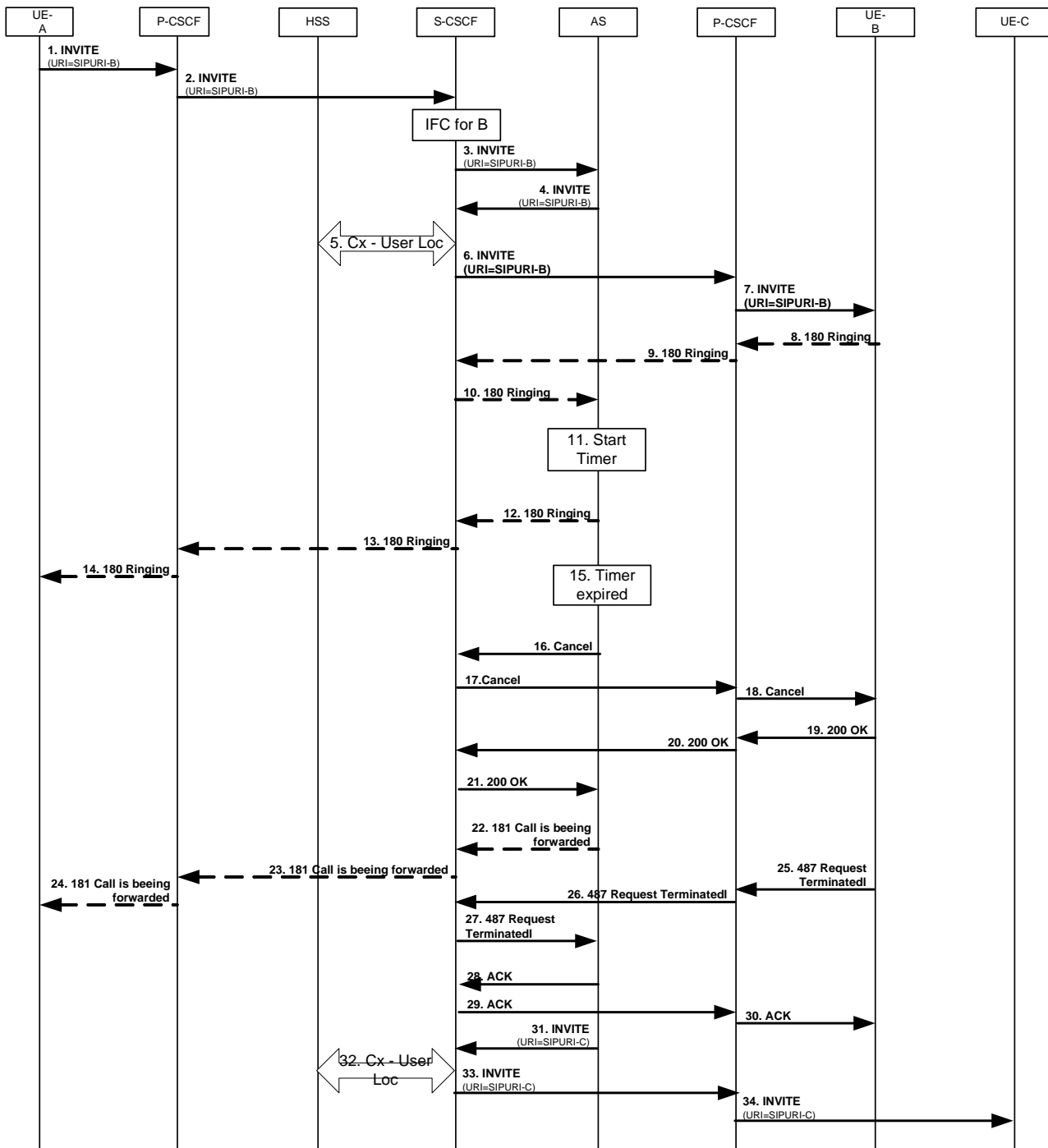

Figure A.3a

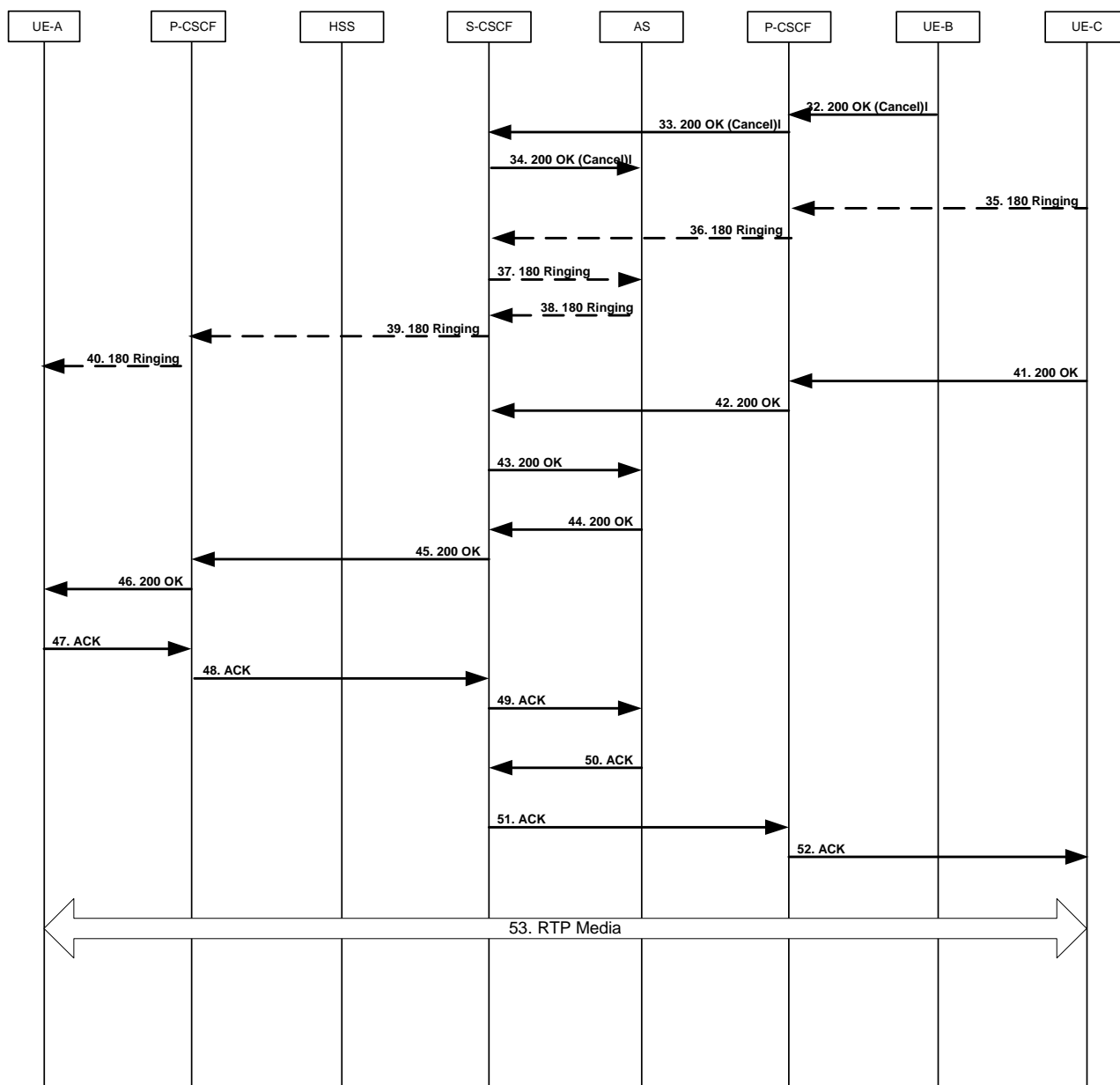

Figure A.3b

User B has activated the CFNR service.

User A is sending a communication request towards User B:

- 1 to 2) Initial INVITE request towards User B. The URI-B is subscribed to the CFU service. - see example in table A.1.1-1
- 3) Using the IFC the INVITE is forwarded to the AS.
- 4) The INVITE request is forwarded to User B due to normal communication procedures.
- 5) The non-reply timer in the AS is started.
- 6 to 7) The INVITE is forwarded to User B due to normal communication procedures.
- 8 to 14) A 180 is sent back to the originating user indicating that the terminating UE is ringing.
- 15) The timer expires.

16 to 18) Depending on the value of subscription option 'Originating user receives notification that his communication has been diverted (forwarded or deflected)', a 181 (Call Is Being Forwarded) response is sent towards the User A indicating that the communication is diverted.

19 to 21) To release the communication to User B the AS sends a CANCEL request.

22 to 27) A 487 (Request Terminated) response with a ACK request finalize the termination of the dialog between AS and UE:B.

28 to 31) An INVITE request including URI-C as destination is sent back towards the UE:C. Additional the History-Info header is included.

28) An INVITE request including URI-C as destination is sent back to the S-CSCF. Additional the History-Info header is included. - see example in table A.1.3-28.

Table A.1.3-28: INVITE request (AS to S-CSCF)

```

INVITE sip:User-C@example.com;target=sip:user2_public1@home1.net%3bgr%362ad8950e-48a5-4a74-8d99-
ad76cc7fc74;cause 408 SIP/2.0
Via: SIP/2.0/UDP as.home1.net;branch=z9hG4bK712z34.1,
SIP/2.0/UDP scscf1.home1.net;branch=z9hG4bK332b23.1,
SIP/2.0/UDP pcsf1.home1.net;branch=z9hG4bK240f34.1,
SIP/2.0/UDP [5555::aaa:bbb:ccc:ddd]:1357;comp=sigcomp;branch=z9hG4bKnashds7
Max-Forwards: 67
Record-Route: <sip:as.home1.net>, <sip:scscf1.home1.net;lr>,<sip:pcsf1.home1.net;lr>
Route: <sip:scscf1.home1.net;lr>
P-Asserted-Identity: "John Doe" <sip:user1_public1@home1.net>
P-Access-Network-Info:
Privacy:
From: <sip:user1_public1@home1.net>;tag=171828
To: sip:user2_public1@home1.net;gr=2ad8950e-48a5-4a74-8d99-ad76cc7fc74c
Call-ID:
Cseq:
Require:
Proxy-Require:
Supported:
Security-Verify:
Contact:
Allow:
Accept:
Accept-Contact:
P-Asserted-Service: urn:urn-7:3gpp-service.ims.icsi.mmtel
History-Info: <sip:user2_public1@home1.net;gr=2ad8950e-48a5-4a74-8d99-
ad76cc7fc74c;>index=1,<sip:User-C@example.com;target=sip:user2_public1@home1.net%3bgr%362ad8950e-
48a5-4a74-8d99-ad76cc7fc74;cause 408>index=1.1
Content-Type:
Content-Length:

v=
o=
s=
c=
t=
m=
a=
a=
b=
a=
a=
a=
a=
a=
a=
a=
a=
a=
a=
m=
a=
a=
b=
a=
a=
a=
a=
a=
a=

```

a= a=

29 to 31) An INVITE request including URI-C as destination is routed to UE C.

32 to 34) The 200 (OK) response for the CANCEL request is sent back to the User-A.

35 to 40) A 180 (Ringing) response is sent back to the originating user including a History-Info header as shown above. If no restriction is given the diverted to user will be presented at the UE of User A.

41 to 46) The 200 (OK) response is sent back to the User-A.

47 to 52) The ACK request is sent back to User-B.

53)RTP media is established.

A.1.4 Communication Forwarding on Busy

Figures A.4a and A.4b shows an example signalling flow for a successful communication forwarding on busy based on an AS providing the forwarding.

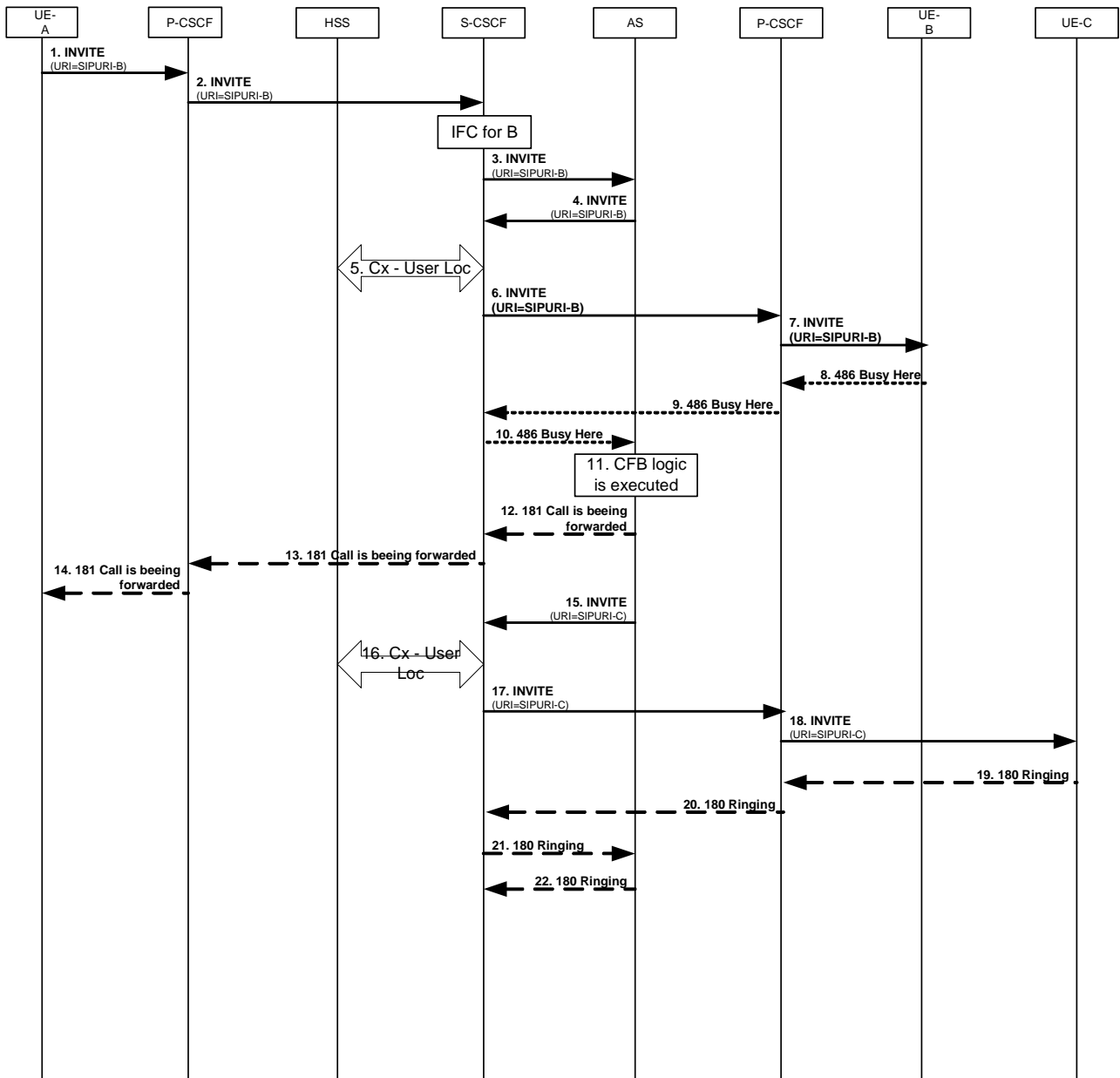

Figure A.4a

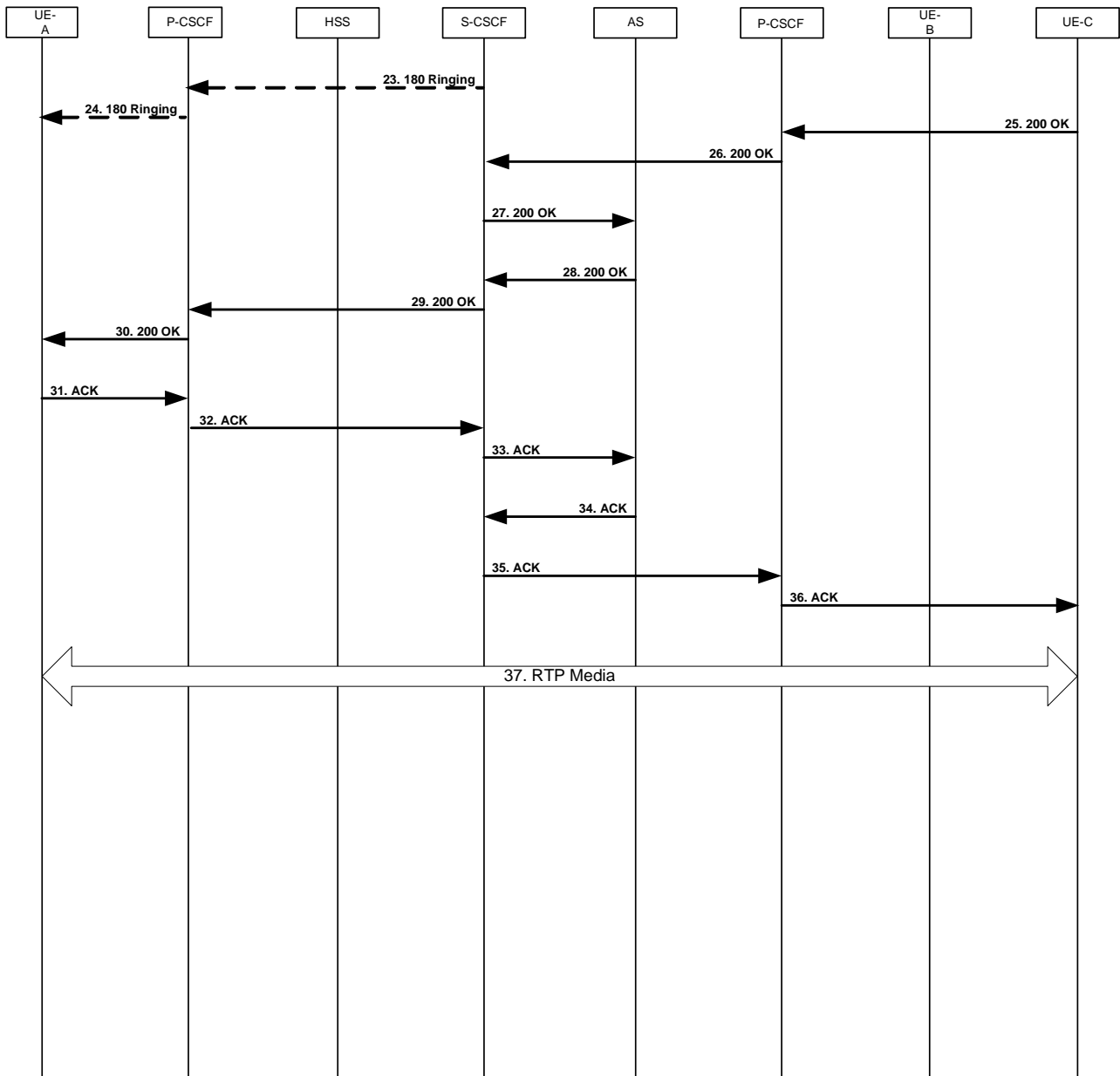

Figure A.4b

A.1.5 Communication Forwarding Not Logged-in (CFNL)

Figure A.5 shows an example signalling flow for a successful communication forwarding on not logged-in based on an AS providing the forwarding.

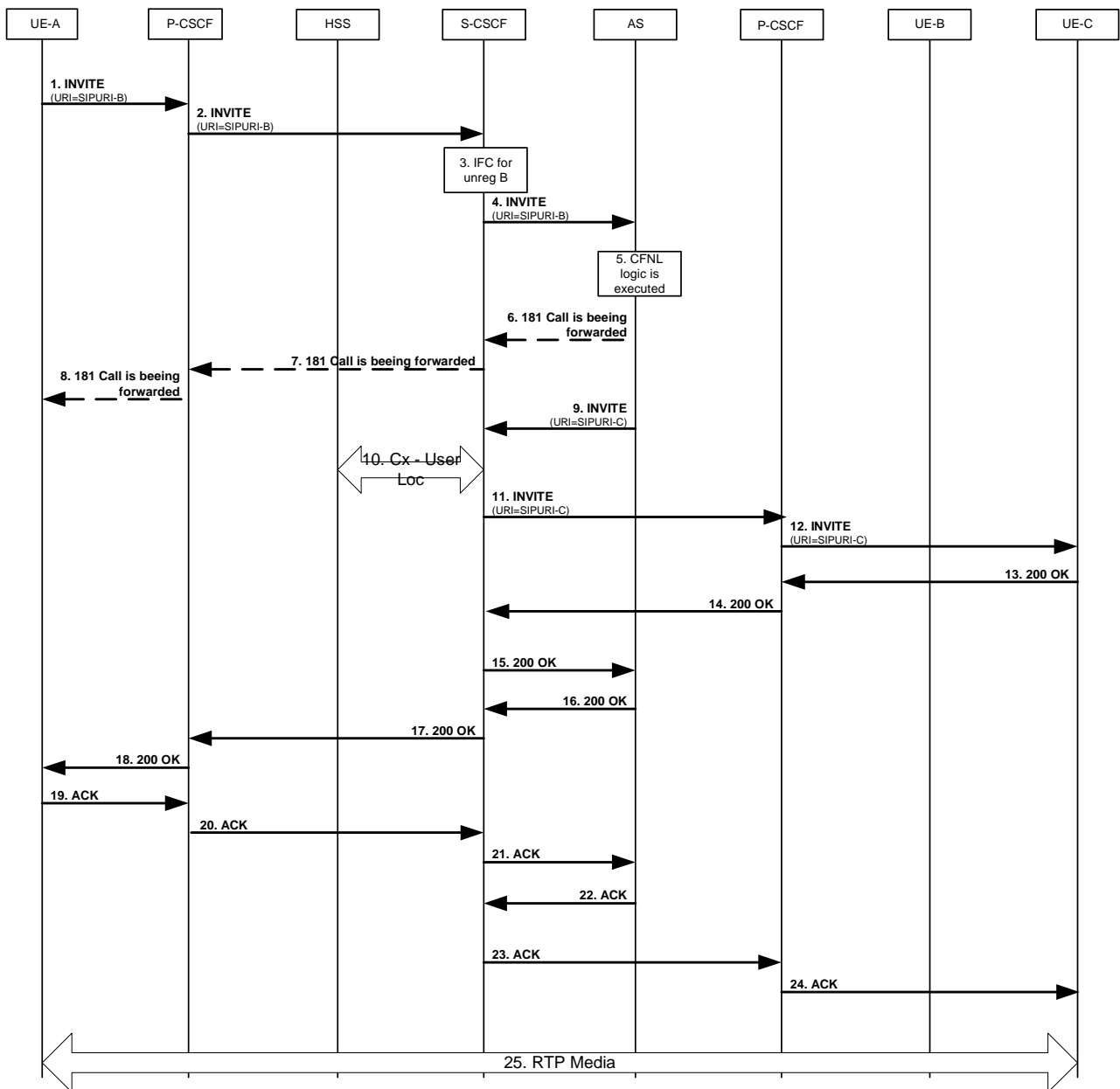

Figure A.5

A.1.6 Void

A.2 Interworking

A.2.1 Communication Forwarding unconditional

Figure A.6b shows an example signalling flow for a successful communication forwarding unconditional based on an AS providing the forwarding, with the originating user in the PSTN.

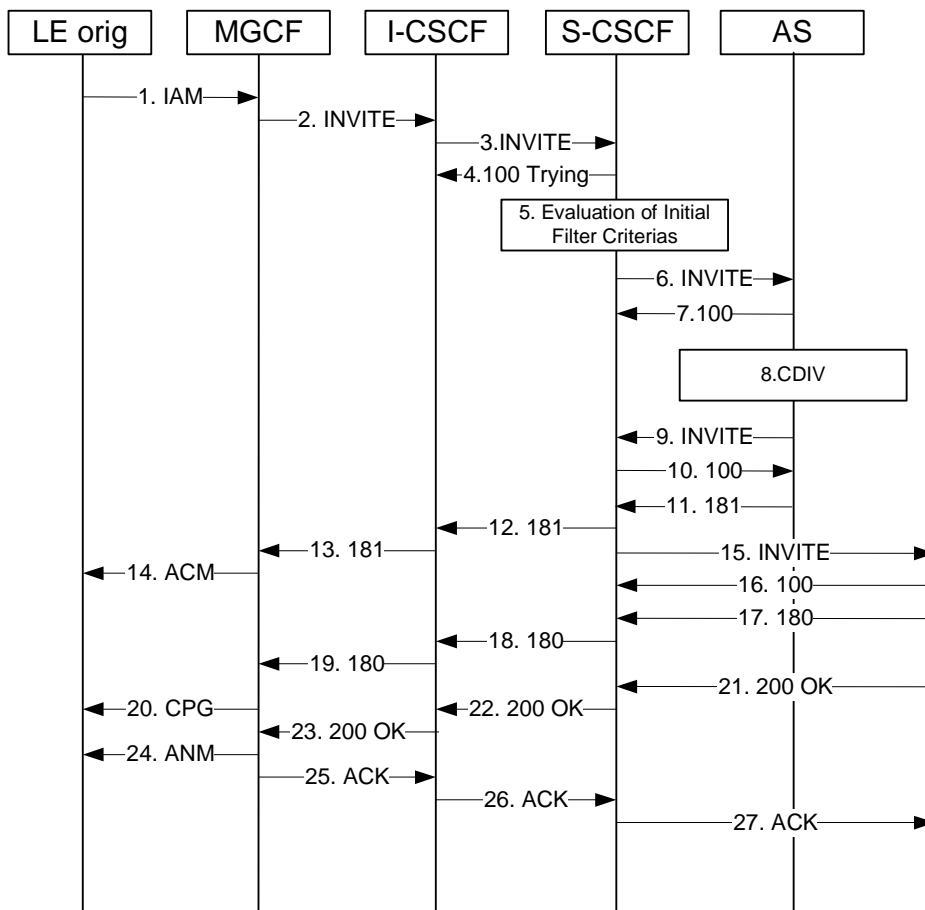

Figure A.6b: Call Forwarding Unconditional

A.2.2 Communication Deflection

Figure A.7 shows an example signalling flow for a successful communication deflection based on an AS providing the forwarding, with the originating user in the PSTN.

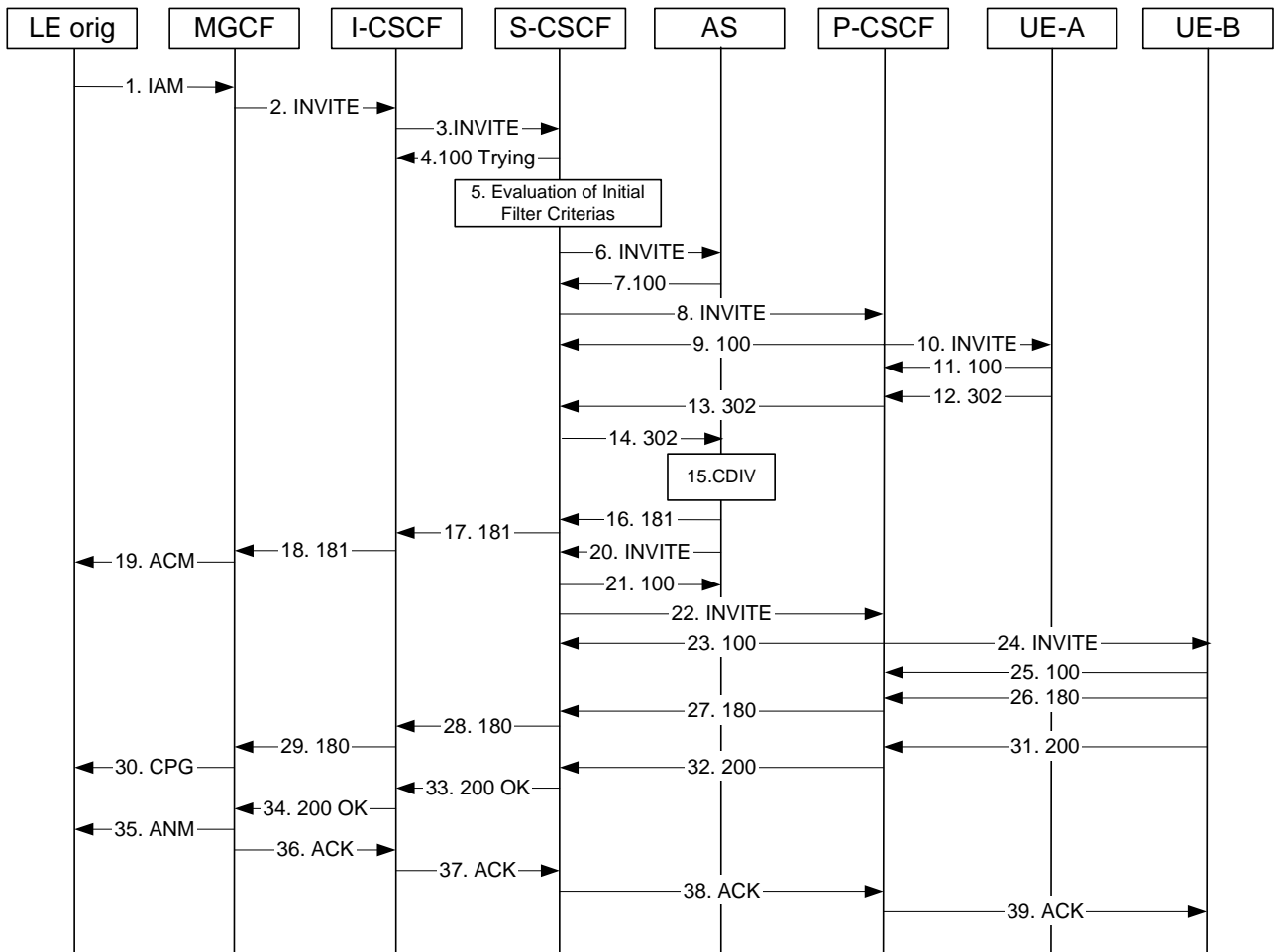

Figure A.7

Annex B (informative): Example of filter criteria

This annex provides an example of a filter criterion that triggers SIP requests that are subject to initial filter criteria evaluation.

An example of an IFC when the CDIV supplementary service is active at the diverting S-CSCF is:

- Method: INVITE.

Annex C (informative): Coding considerations

This annex provides an interpretation of the coding of the cause-param URI parameter specified in RFC 4458 [14]

The cause specified in RFC 4458 [14] has the following syntax:

```
cause-param      = "cause" EQUAL Status-Code
```

The Status-Code is originally specified in RFC 3261 [6] as a sequence of 3 digits. It is noted that the Status-Code simply indicates that it is composed of 3 digits, without indicating the list of possible values. In particular, Status-Code is not bound to and must not be confused with the 3 digit numbers defined for SIP responses in RFC 3261 [6]. The Status-Code is used to hold the redirecting reason.

For the purpose of legibility, the cause-param specified in RFC 4458 [14] is interpreted according to the following syntax:

```
cause-param      = "cause" EQUAL Status-Code
Status-Code      = "404" ; Unknown/Not available
                  /  "486" ; User Busy
                  /  "408" ; No Reply
                  /  "302" ; Unconditional
                  /  "487" ; Deflection during alerting
                  /  "480" ; Deflection during immediate response
                  /  "503" ; Mobile subscriber not reachable
```

Annex D (informative):
Void

Annex E (normative):
Void

Annex F (informative): Change history

Change history							
Date	TSG #	TSG Doc.	CR	Rev	Subject/Comment	Old	New
2008-01					Publication as ETSI TS 183 004		2.4.0
2008-01					Conversion to 3GPP TS 24.504	2.4.0	2.4.1
2008-01					Technically identical copy as 3GPP TS 24.604 as basis for further development.	2.4.1	2.4.2
2008-02					Implemented C1-080096	2.4.2	2.5.0
2008-04					Implemented C1-081199, C1-081359, C1-081081, C1-081080, C1-081079, C1-080876	2.5.0	2.6.0
2008-04					Completed implemented of C1-081359: removed of 'otherwise' in subclause 4.5.2.6.5	2.6.0	2.6.1
2008-05					Implemented C1-081908, C1-081920 (contributor notes in 4.4.1.2 and 4.5.2.6.1 were not introduced), C1-082055, C1-081547, C1-081549, C1-081714 In addition, some editorial enhancements were performed in 4.5.2.6.2.2, 4.5.2.6.2.3, 4.5.2.6.4, 4.9.1.1, A.1.2	2.6.1	2.7.0
2008-05					Editorial corrections done by MCC	2.7.0	2.7.1
2008-06	CT-40	CP-080325			CP-080325 was approved by CT#40 and version 8.0.0 is created by MCC for publishing	2.7.1	8.0.0
2008-09	CT-41	CP-080533	0001	2	Clarification of B2BUA and Proxy roles for AS	8.0.0	8.1.0
2008-09	CT-41	CP-080533	0002		Correction of terminology	8.0.0	8.1.0
2008-09	CT-41	CP-080533	0003	1	Correction of notification service activation	8.0.0	8.1.0
2008-09	CT-41	CP-080521	0004	1	Correction of subscription options	8.0.0	8.1.0
2008-09	CT-41	CP-080521	0005	1	Value of "No reply timer" for CDIV	8.0.0	8.1.0
2008-09	CT-41	CP-080539	0006	2	Allow SIP based user configuration mechanism for configuring supplementary services	8.0.0	8.1.0
2008-09	CT-41	CP-080533	0007	1	Applicability statement in scope	8.0.0	8.1.0
2008-12	CT-42	CP-080852	0008	2	Aligning XML Schema with draft-saklikar-communication-diversion-notification	8.1.0	8.2.0
2008-12	CT-42	CP-080864	0011	2	Interaction between SIP and Ut based service configuration	8.1.0	8.2.0
2008-12	CT-42	CP-080852	0012	3	CR on 24604 CDIV XML correction	8.1.0	8.2.0
2008-12	CT-42	CP-080839	0013	3	Alignment with 29.292	8.1.0	8.2.0
2008-12	CT-42	CP-080865	0015	1	Fixed the flows and schema	8.1.0	8.2.0
2008-12	CT-42				Editorial cleanup by MCC	8.1.0	8.2.0
2009-03	CT-43	CP-090121	0016		Correction of URN-value for Service Identifiers	8.2.0	8.3.0
2009-03	CT-43	CP-090212	0017	2	Correct reference	8.2.0	8.3.0
2009-03	CT-43	CP-090124	0019	1	cause-param clarification and corrections	8.2.0	8.3.0
2009-03	CT-43	CP-090137	0020	1	NoReply Timer XML Schema	8.2.0	8.3.0
2009-06	CT-44	CP-090402	0021	2	Setting of the cause parameter when when an AS forwards a communication	8.3.0	8.4.0
2009-06	CT-44	CP-090432	0022	2	Service capability indication for CDIV	8.4.0	9.0.0
2009-09	CT-45	CP-090687	0023		Media capabilities for Call Diversion	9.0.0	9.1.0
2009-09	CT-45	CP-090662	0026	1	Correcting GRUU matching	9.0.0	9.1.0
2009-09	CT-45	CP-090662	0028		Updating internet draft names and versions	9.0.0	9.1.0
2009-09	CT-45	CP-090687	0030		Supported target type in CDIV	9.0.0	9.1.0
2009-12	CT-46	CP-090928	0033	2	CDIV serv-cap corrections and example	9.1.0	9.2.0
2009-12	CT-46	CP-090923	0034	1	Alignment of cp:identity interpretation between ICB and CDIV	9.1.0	9.2.0
2009-12	CT-46	CP-090923	0036	1	Determining if served user shall be added to History-Info	9.1.0	9.2.0
2009-12	CT-46	CP-090894	0041		Updating of GRUU references	9.1.0	9.2.0
2009-12	CT-46	CP-090923	0042	2	Correction of CDIV service interactions	9.1.0	9.2.0
2010-03	CT-47	CP-100141	0043	1	Cleanup of CDIV	9.2.0	9.3.0
2010-06	CT-48	CP-100341	0045		NoReplyTimer description is not an action	9.3.0	9.4.0
2010-09	CT-49	CP-100488	0047	2	CDIV corrections	9.4.0	9.5.0
2010-09	CT-49	CP-100635	0049	1	Removing editor's note about signalling outage	9.4.0	9.5.0
2010-12	CT-50	CP-100864	0050	1	Correcting CDIV errors	9.5.0	10.0.0
2010-12	CT-50	CP-100864	0051		Correcting interaction CDIV-ECT	9.5.0	10.0.0
2011-03	CT-51	CP-110168	0055	1	Correct CDIV-TIR interaction	10.0.0	10.1.0
2011-03	CT-51	CP-110165	0058	2	Correct reference	10.0.0	10.1.0
2011-03	CT-53	CP-110657	0060	2	<conditions> element values	10.1.0	10.2.0

2011-12	CT-54	CP-110857	0075	1	Correction of Communication Deflection during alerting	10.2.0	10.3.0
2012-03	CT-55	CP-120097	0082	2	CDIV building of Index	10.3.0	10.4.0
2012-06	CT-56	CP-120291	0091	1	Issues with reminder notification of diversion	10.4.0	10.5.0
2013-06	CT-60	CP-130224	0099	6	Update reference	10.5.0	10.6.0
2013-06	CT-60	CP-130224	0103	2	Correcting missing MIME type definition	10.5.0	10.6.0
2013-06	CT-60	CP-130226	0112		Removal of Editor's Note	10.5.0	10.6.0
2013-09	CT-61	CP-130484	0117		Update reference	10.6.0	10.7.0
2013-12	CT-62	CP-130723	0122	3	Correction on procedures at the diverting AS of CFNR	10.7.0	10.8.0
2014-06	CT-64	CP-140297	0133	1	Removal of the CDIVN service	10.8.0	10.9.0
2015-06	CT-68	CP-150290	0163	3	CDIV – tel and SIP URI correction	10.9.0	10.10.0
2015-09	CT-69	CP-150503	0170	1	SIP URI conversion in CDIV	10.10.0	10.11.0

History

Document history		
V10.1.0	April 2011	Publication
V10.2.0	October 2011	Publication
V10.3.0	January 2012	Publication
V10.4.0	March 2012	Publication
V10.5.0	July 2012	Publication
V10.6.0	July 2013	Publication
V10.7.0	October 2013	Publication
V10.8.0	January 2014	Publication
V10.9.0	July 2014	Publication
V10.10.0	July 2015	Publication
V10.11.0	October 2015	Publication