

ETSI TS 123 285 V15.1.0 (2018-07)



**Universal Mobile Telecommunications System (UMTS);
LTE;
Architecture enhancements for V2X services
(3GPP TS 23.285 version 15.1.0 Release 15)**



ReferenceRTS/TSGS-0223285v10

KeywordsLTE,UMTS

ETSI

650 Route des Lucioles
F-06921 Sophia Antipolis Cedex - FRANCE

Tel.: +33 4 92 94 42 00 Fax: +33 4 93 65 47 16

Siret N° 348 623 562 00017 - NAF 742 C
Association à but non lucratif enregistrée à la
Sous-Préfecture de Grasse (06) N° 7803/88

Important notice

The present document can be downloaded from:

<http://www.etsi.org/standards-search>

The present document may be made available in electronic versions and/or in print. The content of any electronic and/or print versions of the present document shall not be modified without the prior written authorization of ETSI. In case of any existing or perceived difference in contents between such versions and/or in print, the only prevailing document is the print of the Portable Document Format (PDF) version kept on a specific network drive within ETSI Secretariat.

Users of the present document should be aware that the document may be subject to revision or change of status.

Information on the current status of this and other ETSI documents is available at

<https://portal.etsi.org/TB/ETSIDeliverableStatus.aspx>

If you find errors in the present document, please send your comment to one of the following services:

<https://portal.etsi.org/People/CommiteeSupportStaff.aspx>

Copyright Notification

No part may be reproduced or utilized in any form or by any means, electronic or mechanical, including photocopying and microfilm except as authorized by written permission of ETSI.

The content of the PDF version shall not be modified without the written authorization of ETSI.

The copyright and the foregoing restriction extend to reproduction in all media.

© ETSI 2018.

All rights reserved.

DECT™, **PLUGTESTS™**, **UMTS™** and the ETSI logo are trademarks of ETSI registered for the benefit of its Members.
3GPP™ and **LTE™** are trademarks of ETSI registered for the benefit of its Members and
of the 3GPP Organizational Partners.

oneM2M logo is protected for the benefit of its Members.

GSM® and the GSM logo are trademarks registered and owned by the GSM Association.

Intellectual Property Rights

Essential patents

IPRs essential or potentially essential to normative deliverables may have been declared to ETSI. The information pertaining to these essential IPRs, if any, is publicly available for **ETSI members and non-members**, and can be found in ETSI SR 000 314: *"Intellectual Property Rights (IPRs); Essential, or potentially Essential, IPRs notified to ETSI in respect of ETSI standards"*, which is available from the ETSI Secretariat. Latest updates are available on the ETSI Web server (<https://ipr.etsi.org/>).

Pursuant to the ETSI IPR Policy, no investigation, including IPR searches, has been carried out by ETSI. No guarantee can be given as to the existence of other IPRs not referenced in ETSI SR 000 314 (or the updates on the ETSI Web server) which are, or may be, or may become, essential to the present document.

Trademarks

The present document may include trademarks and/or tradenames which are asserted and/or registered by their owners. ETSI claims no ownership of these except for any which are indicated as being the property of ETSI, and conveys no right to use or reproduce any trademark and/or tradename. Mention of those trademarks in the present document does not constitute an endorsement by ETSI of products, services or organizations associated with those trademarks.

Foreword

This Technical Specification (TS) has been produced by ETSI 3rd Generation Partnership Project (3GPP).

The present document may refer to technical specifications or reports using their 3GPP identities, UMTS identities or GSM identities. These should be interpreted as being references to the corresponding ETSI deliverables.

The cross reference between GSM, UMTS, 3GPP and ETSI identities can be found under <http://webapp.etsi.org/key/queryform.asp>.

Modal verbs terminology

In the present document "**shall**", "**shall not**", "**should**", "**should not**", "**may**", "**need not**", "**will**", "**will not**", "**can**" and "**cannot**" are to be interpreted as described in clause 3.2 of the [ETSI Drafting Rules](#) (Verbal forms for the expression of provisions).

"**must**" and "**must not**" are **NOT** allowed in ETSI deliverables except when used in direct citation.

Contents

Intellectual Property Rights	2
Foreword.....	2
Modal verbs terminology.....	2
Foreword.....	5
1 Scope	6
2 References	6
3 Definitions and abbreviations.....	7
3.1 Definitions	7
3.2 Abbreviations	8
4 Architecture model and concepts	8
4.1 General concept.....	8
4.2 Architectural reference model	8
4.2.1 PC5 and LTE-Uu based V2X architecture reference model	8
4.2.1.1 Non-roaming architecture for PC5 and LTE-Uu based V2X communication	8
4.2.1.2 Roaming architecture for PC5 and LTE-Uu based V2X communication	9
4.2.1.3 Inter-PLMN architecture for PC5 and LTE-Uu based V2X communication	10
4.2.2 MBMS for LTE-Uu based V2X architecture reference model	11
4.2.3 Reference points	12
4.3 Functional entities	13
4.3.1 V2X Control Function	13
4.3.1.1 General	13
4.3.1.2 V2X Control Function discovery	13
4.3.2 UE.....	13
4.3.3 V2X Application Server	13
4.3.4 MME.....	14
4.3.5 BM-SC.....	14
4.3.6 MBMS-GW	14
4.4 High level function.....	14
4.4.1 Authorization and Provisioning for V2X communications.....	14
4.4.1.1 Authorization and provisioning for V2X communications over PC5 reference point	14
4.4.1.1.1 General	14
4.4.1.1.2 Policy/Parameter provisioning	15
4.4.1.1.3 Principles for applying parameters for V2X communications over PC5 reference point.....	16
4.4.1.2 Authorization and provisioning for V2X communications over LTE-Uu reference point.....	17
4.4.1.2.1 General	17
4.4.1.2.2 Policy/Parameter provisioning	17
4.4.2 V2X message transmission/reception over PC5 reference point	17
4.4.3 V2X message transmission/reception over LTE-Uu reference point.....	18
4.4.3.1 General	18
4.4.3.2 V2X message transmission/reception via unicast	18
4.4.3.3 V2X message reception via MBMS.....	19
4.4.4 V2X Application Server discovery	19
4.4.4.1 General	19
4.4.4.2 Multiple V2X Application Server and Localized V2X Application Server discovery and routing	19
4.4.5 QoS handling for V2X communication	20
4.4.5.1 QoS handling for V2X communication over PC5 reference point.....	20
4.4.5.2 QoS handling for V2X communication over LTE-Uu reference point	20
4.4.6 Subscription to V2X services.....	21
4.4.7 MBMS bearer announcement for V2X use.....	21
4.4.7.1 General	21
4.4.7.2 User Service Description for V2X Communication (V2X USD)	21
4.4.7.3 User Service Description for V2X Application Server Discovery (V2X Server USD)	22
4.4.8 Support for V2X communication for UEs in limited service state	22
4.4.9 Charging support for V2X communication	23

4.4.9.1	Charging support for V2X communication over PC5 reference point	23
4.4.9.2	Charging support for V2X communication over LTE-Uu reference point	23
4.4.10	Security and privacy protection support for V2X communication	23
4.5	Identifiers	23
4.5.1	Identifiers for V2X communication over PC5 reference point	23
5	Functional description and information flows.....	24
5.1	Control and user plane stacks	24
5.1.1	User plane for PC5 reference point supporting V2X services	24
5.2	Service authorization and update for V2X communications	24
5.2.1	Service authorization procedures	24
5.2.2	Service authorization update procedures	24
5.3	Procedure for V2X communication over PC5 reference point	24
5.4	Procedure for V2X communication over LTE-Uu reference point	24
5.4.1	V2X Application Server discovery using MBMS	24
5.4.1.1	General	24
5.4.1.2	Procedures for receiving V2X Application Server information via MBMS	25
5.4.2	Procedure for V2X communication with MBMS	25
5.4.2.1	MBMS service area mapping	25
5.4.2.1.1	General	25
5.4.2.1.2	Functional Description	26
5.4.2.2	Local MBMS based MBMS data delivery	26
5.5	V2X impacts to EPC procedures.....	28
5.5.1	E-UTRAN attach procedure for UE.....	28
5.5.2	Service Request procedures for UE	28
5.5.3	S1 Handover procedures for UE	28
5.5.4	X2 Handover procedures for UE	28
5.5.5	Tracking Area Update procedure for UE.....	29
5.5.6	Insert Subscriber Data procedure for UE.....	29
5.5.7	Delete Subscriber Data procedure for UE.....	29
Annex A (informative):	Road Side Unit (RSU) implementation options.....	30
Annex B (informative):	Localized MBMS deployment options	31
B.1	General Description.....	31
B.2	Option of localized MBMS CN functions.....	31
B.3	Option of localized user plane of MBMS CN functions	32
Annex C (informative):	Example hybrid operation modes for V2X communication over PC5 and LTE-Uu	33
C.1	General	33
C.2	PC5 based V2X communication with MBMS reception	33
C.3	Simultaneous LTE-Uu based and PC5 based V2X communication without MBMS	33
Annex D (informative):	V2X Message Distribution Server deployment option	35
D.1	General Description.....	35
Annex E (informative):	Change history	36
History		37

Foreword

This Technical Report has been produced by the 3rd Generation Partnership Project (3GPP).

The contents of the present document are subject to continuing work within the TSG and may change following formal TSG approval. Should the TSG modify the contents of the present document, it will be re-released by the TSG with an identifying change of release date and an increase in version number as follows:

Version x.y.z

where:

- x the first digit:
 - 1 presented to TSG for information;
 - 2 presented to TSG for approval;
 - 3 or greater indicates TSG approved document under change control.
- y the second digit is incremented for all changes of substance, i.e. technical enhancements, corrections, updates, etc.
- z the third digit is incremented when editorial only changes have been incorporated in the document.

1 Scope

The present document specifies architecture enhancements to facilitate vehicular communications for Vehicle-to-Everything (V2X) services, which includes Vehicle-to-Vehicle (V2V), Vehicle-to-Pedestrian (V2P), Vehicle-to-Infrastructure (V2I), and Vehicle-to-Network (V2N), according to the use cases and service requirements defined in TS 22.185 [2].

The following vehicular communications for V2X services are specified:

- V2X communication over PC5 reference point.
- V2X communication over LTE-Uu reference point.

2 References

The following documents contain provisions which, through reference in this text, constitute provisions of the present document.

- References are either specific (identified by date of publication, edition number, version number, etc.) or non-specific.
- For a specific reference, subsequent revisions do not apply.
- For a non-specific reference, the latest version applies. In the case of a reference to a 3GPP document (including a GSM document), a non-specific reference implicitly refers to the latest version of that document *in the same Release as the present document*.

- [1] 3GPP TR 21.905: "Vocabulary for 3GPP Specifications".
- [2] 3GPP TS 22.185: "Service requirements for V2X services".
- [3] ISO TS 17419:2014: "Intelligent Transport Systems - Cooperative systems - Classification and management of ITS applications in a global context".
- [4] IEEE Std 1609.12-2016: "[IEEE Standard for Wireless Access in Vehicular Environments \(WAVE\) - Identifier Allocations](#)".
- [5] 3GPP TS 23.303: "Proximity-based Services (ProSe); Stage 2".
- [6] 3GPP TS 23.401: "General Packet Radio Service (GPRS) enhancements for Evolved Universal Terrestrial Radio Access Network (E-UTRAN) access".
- [7] 3GPP TS 23.468: "Group Communication System Enablers for LTE (GCSE_LTE)".
- [8] 3GPP TS 23.246: "Multimedia Broadcast/Multicast Service (MBMS); Architecture and functional description".
- [9] 3GPP TS 36.331: "Evolved Universal Terrestrial Radio Access (E-UTRA); Radio Resource Control (RRC); Protocol specification".
- [10] 3GPP TS 36.300: "Evolved Universal Terrestrial Radio Access (E-UTRA) and Evolved Universal Terrestrial Radio Access Network (E-UTRAN); Overall description; Stage 2".
- [11] 3GPP TS 26.346: "Multimedia Broadcast/Multicast Service (MBMS); Protocols and codecs".
- [12] 3GPP TS 23.203: "Policy and charging control architecture".
- [13] IEEE Std 1609.3-2010: "IEEE Standard for Wireless Access in Vehicular Environments (WAVE) - Networking Services".
- [14] ISO 29281-1:2013: "Intelligent Transport Systems - Communications access for land mobiles (CALM) - Non-IP networking - Part 1: Fast networking & transport layer protocol (FNTP)".

- [15] 3GPP TS 29.272: "Evolved Packet System (EPS); Mobility Management Entity (MME) and Serving GPRS Support Node (SGSN) related interfaces based on Diameter protocol".
- [16] ETSI TS 102 637-2 V1.2.1: "Intelligent Transport Systems (ITS); Vehicular Communications; Basic Set of Applications; Part 2: Specification of Cooperative Awareness Basic Service".
- [17] ETSI TS 102 637-3 V1.1.1: "Intelligent Transport Systems (ITS); Vehicular Communications; Basic Set of Applications; Part 3: Specifications of Decentralized Environmental Notification Basic Service".
- [18] 3GPP TS 32.277: "Proximity-based Services (ProSe) charging".
- [19] Void.
- [20] 3GPP TS 32.251: "Telecommunication management; Charging management; Packet Switched (PS) domain charging".
- [21] 3GPP TS 32.273: "Telecommunication management; Charging management; Multimedia Broadcast and Multicast Service (MBMS) charging".
- [22] 3GPP TS 36.304: "Evolved Universal Terrestrial Radio Access (E-UTRA); User Equipment (UE) procedures in idle mode".
- [23] 3GPP TS 23.122: "Non-Access-Stratum (NAS) functions related to Mobile Station (MS) in idle mode".
- [24] Void.
- [25] 3GPP TS 33.185: "Security aspect for LTE support of V2X services".
- [26] 3GPP TS 36.321: "Evolved Universal Terrestrial Radio Access (E-UTRA); Medium Access Control (MAC) protocol specification".
- [27] 3GPP TS 24.386: "User Equipment (UE) to V2X control function; protocol aspects; Stage 3".
- [28] 3GPP TS 22.186: "Enhancement of 3GPP support for V2X scenarios; Stage 1".

3 Definitions and abbreviations

3.1 Definitions

For the purposes of the present document, the terms and definitions given in TR 21.905 [1] and the following apply. A term defined in the present document takes precedence over the definition of the same term, if any, in TR 21.905 [1].

For the purposes of the present document, the following terms and definitions given in ISO TS 17419:2014 [3] apply:

Intelligent Transport Systems

ITS Application Identifier

For the purposes of the present document, the following term and definition given in IEEE Std 1609.12-2016 [4] apply:

Provider Service Identifier

For the purposes of the present document, the following term and definition given in TS 22.185 [2] apply:

Road Side Unit

For the purposes of the present document, the following term and definition given in TS 23.303 [5] apply:

Geographical Area

3.2 Abbreviations

For the purposes of the present document, the abbreviations given in TR 21.905 [1] and the following apply. An abbreviation defined in the present document takes precedence over the definition of the same abbreviation, if any, in TR 21.905 [1].

C-TEID	Common-Tunnel Endpoint Identifier
ITS	Intelligent Transport Systems
ITS-AID	ITS Application Identifier
PSID	Provider Service Identifier
RSU	Road Side Unit
SIPTO@LN	SIPTO at the Local Network
USD	User Service Description
V2X	Vehicle-to-Everything

4 Architecture model and concepts

4.1 General concept

There are two modes of operation for V2X communication, namely over the PC5 and over LTE-Uu. LTE-Uu can be unicast and/or MBMS. These two operation modes may be used by a UE independently for transmission and reception, e.g. a UE can use MBMS for reception without using LTE-Uu for transmission. A UE may also receive V2X messages via LTE-Uu unicast downlink.

For both operation modes, the following principles apply:

- V2X Application Servers e.g. in different domains can communicate with each other for the exchange of V2X messages. The interface between V2X Application Servers and the methods of the exchange of messages between V2X Application Servers is out of scope of 3GPP.
- ProSe discovery feature (TS 23.303 [5] clause 5.3 ProSe Direct Discovery) is not required for V2X Services.

NOTE: ProSe discovery feature can be used by a V2X supporting UE, but that is up to UE implementation.

- Subject to regional regulations, lawful interception requirements apply to V2X Services.
- An RSU is not an architectural entity, but an implementation option. This is achieved by collocating a V2X application logic/server with some entities of the 3GPP system, as shown in examples in Annex A.

4.2 Architectural reference model

4.2.1 PC5 and LTE-Uu based V2X architecture reference model

4.2.1.1 Non-roaming architecture for PC5 and LTE-Uu based V2X communication

Figure 4.2.1.1-1 shows the high level view of the non-roaming architecture for PC5 and LTE-Uu based V2X communication.

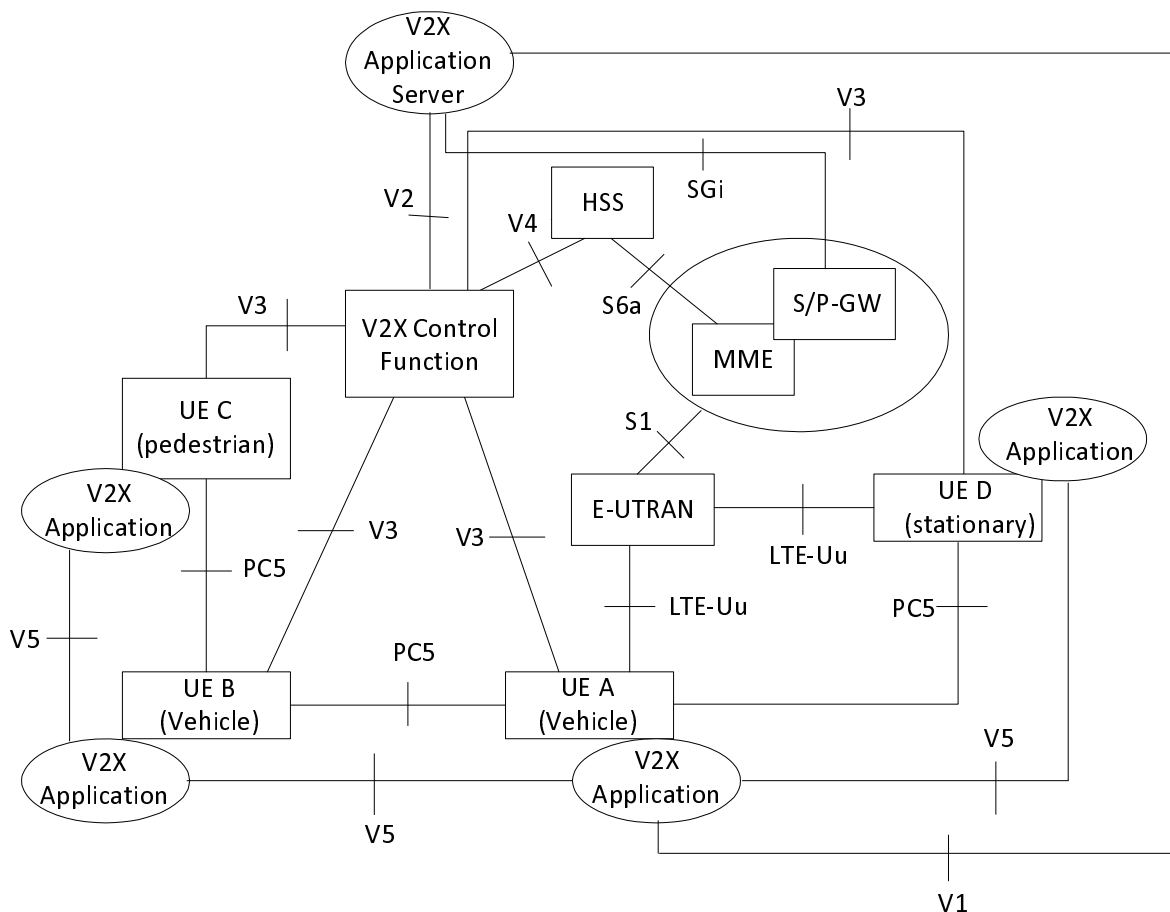

Figure 4.2.1.1-1: Non-roaming reference architecture for PC5 and LTE-Uu based V2X communication

4.2.1.2 Roaming architecture for PC5 and LTE-Uu based V2X communication

Figure 4.2.1.2-1 shows the high level view of the roaming architecture for PC5 and LTE-Uu based V2X communication. In this figure, UE A uses a subscription of PLMN A and UE B uses a subscription of PLMN B; UE A is roaming in PLMN B while UE B is not roaming.

A V2X Application Server may connect to multiple PLMNs, e.g. one V2X Application Server can connect with the V2X Control Function in PLMN A and the V2X Control Function in PLMN B in the figure.

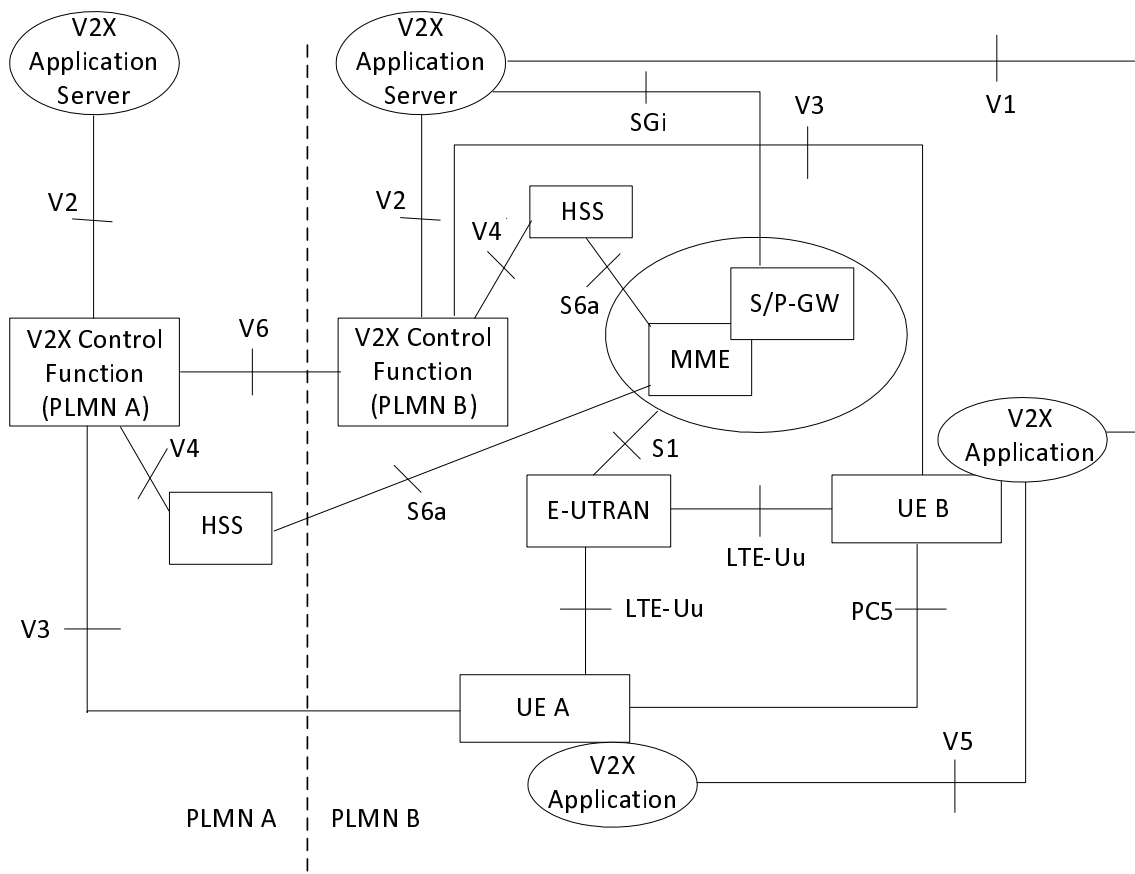

Figure 4.2.1.2-1: Roaming reference architecture for PC5 and LTE-Uu based V2X communication

4.2.1.3 Inter-PLMN architecture for PC5 and LTE-Uu based V2X communication

Figure 4.2.1.3-1 shows the high level view of the inter-PLMN architecture for PC5 and LTE-Uu based V2X communication. In this figure, UE A uses a subscription of PLMN A and UE B uses a subscription of PLMN B; UE A is roaming in PLMN C while UE B is not roaming.

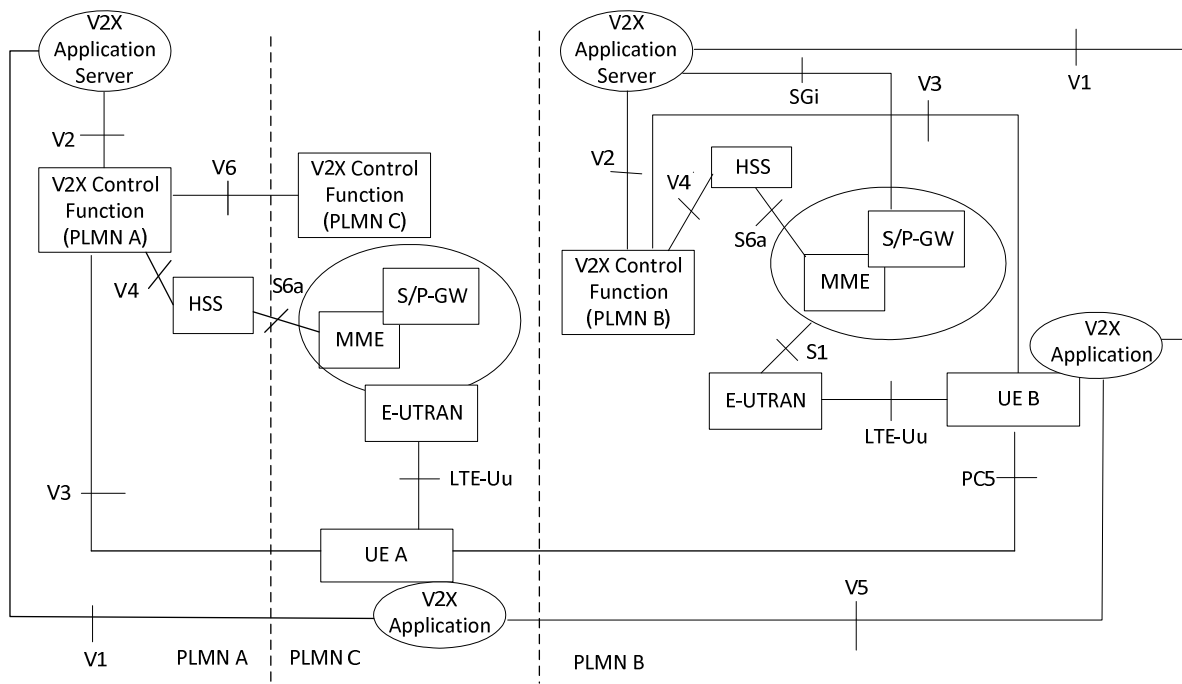

Figure 4.2.1.3-1: Inter-PLMN reference architecture for PC5 and LTE-Uu based V2X communication

4.2.2 MBMS for LTE-Uu based V2X architecture reference model

Figure 4.2.2-1a and figure 4.2.2-1b show the high level view of the reference architectures with MBMS for LTE-Uu based V2X communication. V2X Application Server may apply either MB2 or xMB reference points when managing MBMS service related information via BM-SC, MB2 reference point as defined in TS 23.468 [7] provides functionality related to group communication and xMB reference point as defined in TS 26.346 [11] provides functionality overall for any content and also supports security framework between content provider and BM-SC.

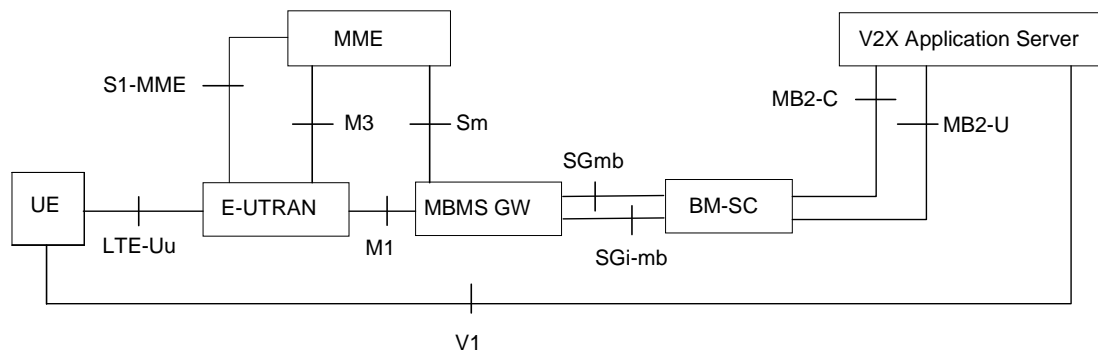

Figure 4.2.2-1a: Reference architecture for MBMS for LTE-Uu based V2X communication via MB2

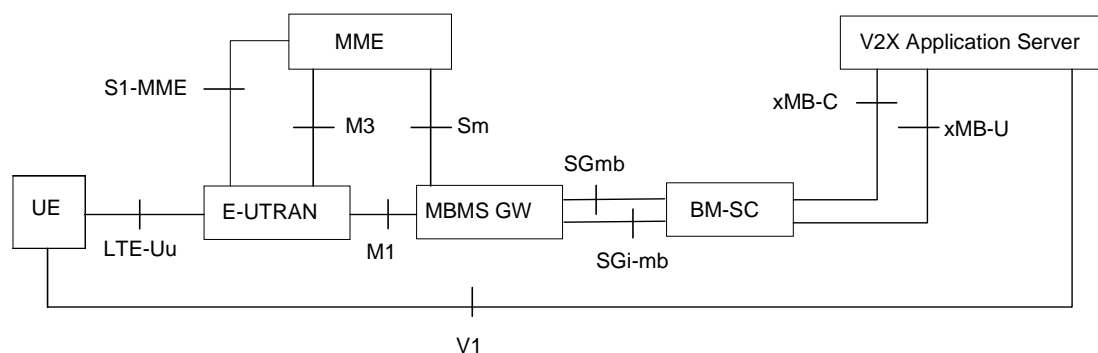

Figure 4.2.2-1b: Reference architecture for MBMS for LTE-Uu based V2X communication via xMB

4.2.3 Reference points

- V1:** The reference point between the V2X application in the UE and in the V2X Application Server. This reference point is out of scope of this specification.
- V2:** The reference point between the V2X Application Server and the V2X Control Function in the operator's network. The V2X Application Server may connect to V2X Control Functions belonging to multiple PLMNs.
- V3:** The reference point between the UE and the V2X Control Function in UE's home PLMN. It is based on the service authorization and provisioning part of the PC3 reference point defined in clause 5.2 of TS 23.303 [5]. It is applicable to both PC5 and LTE-Uu based V2X communication and optionally MBMS and LTE-Uu based V2X communication.
- V4:** The reference point between the HSS and the V2X Control Function in the operator's network.
- V5:** The reference point between the V2X applications in the UEs. This reference point is not specified in this release of the specification.
- V6:** The reference point between the V2X Control Function in the HPLMN and the V2X Control Function in the VPLMN.
- PC5:** The reference point between the UEs used for user plane for ProSe Direct Communication for V2X Service.
- S6a:** In addition to the relevant functions defined in TS 23.401 [6] for S6a, in case of V2X Service S6a is used to download V2X Service related subscription information to MME during E-UTRAN attach procedure or to inform MME subscription information in the HSS has changed.
- S1-MME:** In addition to the relevant functions defined in TS 23.401 [6] for S1-MME, in case of V2X Service it is also used to convey the V2X Service authorization from MME to eNodeB.
- xMB:** The reference point between the V2X Application Server (e.g. Content Provider) and the BM-SC, and defined in TS 26.346 [11].
- MB2:** The reference point between the V2X Application Server and the BM-SC, and defined in TS 23.468 [7].
- SGmb/SGi-mb/M1/M3:** The SGmb/SGi-mb/M1/M3 reference points are internal to the MBMS system and are defined in TS 23.246 [8].
- LTE-Uu:** The reference point between the UE and the E-UTRAN.

4.3 Functional entities

4.3.1 V2X Control Function

4.3.1.1 General

The V2X Control Function is the logical function that is used for network related actions required for V2X. In this version of the specification it is assumed that there is only one logical V2X Control Function in each PLMN that supports V2X Services.

NOTE 1: If multiple V2X Control Functions are deployed within the same PLMN (e.g., for load reasons), then the method to locate the specific V2X Control Function (e.g., through a database lookup, etc.) is not defined in this version of the specification.

V2X Control Function is used to provision the UE with necessary parameters in order to use V2X communication. It is used to provision the UEs with PLMN specific parameters that allow the UE to use V2X in this specific PLMN. V2X Control Function is also used to provision the UE with parameters that are needed when the UE is "not served by E-UTRAN".

V2X Control Function may also be used to obtain V2X USDs for UEs to receive MBMS based V2X traffic, through V2 reference point from the V2X Application Server.

V2X Control Function may also obtain the parameters required for V2X communications over PC5 reference point, from the V2X Application Server via V2 reference point.

NOTE 2: The V2X Control Function in HPLMN can be always reached if Home Routed configuration is applied for PDN connection (e.g., the PDN GW is located in the HPLMN), when such function is supported by the HPLMN. In case of Local Breakout (e.g., the PDN GW is located in the VPLMN), a V2X Control Function Proxy can be deployed by the VPLMN to support UE to Home V2X Control Function communication, if inter-PLMN signalling is required. Whether a PDN connection is provided by Local Breakout or Home Routed is determined by the HSS configuration described in TS 23.401 [6]. The UE is not aware of this and, as such, it will not know which APN can be used for communication with the V2X Control Function, unless the specific APN information is configured in the UE indicating that this APN provides signalling connectivity between the UE and the Home V2X Control Function.

4.3.1.2 V2X Control Function discovery

The V2X Control Function of HPLMN is discovered through interaction with the Domain Name Service function. The FQDN of a V2X Control Function in the Home PLMN may either be pre-configured in the UE, provisioned by the network or self-constructed by the UE, e.g., derived from the PLMN ID of the HPLMN. The IP address of a V2X Control Function in the Home PLMN may also be provisioned to the UE.

4.3.2 UE

The UE may support the following functions:

- Exchange of V2X control information between UE and the V2X Control Function over the V3 reference point.
- Procedures for V2X communication over PC5 reference point and/or LTE-Uu reference point.
- Configuration of parameters for V2X communication (e.g., destination Layer-2 IDs, radio resource parameters, V2X Application Server address information, mapping between service types and V2X frequencies). These parameters can be pre-configured in the UE, or, if in coverage, provisioned by signalling over the V3 reference point from the V2X Control Function in the HPLMN.
- Provided with V2X USDs for receiving MBMS based V2X traffic via existing MBMS service announcement mechanisms, or provisioned from V2X Control Function, or provisioned from the V2X Application Server via V1 reference point.
- Provisioned with V2X Server USDs for receiving V2X Application Server information via MBMS.

4.3.3 V2X Application Server

The V2X Application Server (V2X AS) may support the following capabilities:

- Receiving uplink data from the UE over unicast.
- Delivering data to the UE(s) in a target area using Unicast Delivery and/or MBMS Delivery.
- Mapping from geographic location information to appropriate target MBMS SAI(s) for the broadcast.
- Mapping from geographic location information to appropriate target 3GPP ECGI(s) for the broadcast.
- Mapping from UE provided ECGI to appropriate target MBMS SAI(s) for the broadcast.
- Providing the appropriate ECGI(s) and/or MBMS SAI(s) to BM-SC.
- Pre-configured with Local MBMS (L.MBMS) information (e.g. IP multicast address, multicast source (SSM), C-TEID).
- Pre-configured with L.MBMS's IP address and port number for the user-plane.
- Sending L.MBMS information to the BM-SC.
- Requests BM-SC for allocation/de-allocation of a set of TMGIs.
- Requests BM-SC for activating/deactivating/modifying the MBMS bearer.
- Providing the V2X USDs for UE to receive MBMS based V2X traffic to V2X Control Function.
- Providing the parameters for V2X communications over PC5 reference point to V2X Control Function.
- Providing the parameters for V2X communications over PC5 reference point to UE.

4.3.4 MME

In addition to the functions defined in TS 23.401 [6] and TS 23.246 [8], in case of V2X the MME performs the following functions:

- Obtains subscription information related to V2X as part of the subscription data.
- Provides indication to the E-UTRAN about the UE authorization status on V2X use.

4.3.5 BM-SC

In addition to the functions defined in TS 23.246 [8] and TS 23.468 [7], in case of V2X the BM-SC performs the following functions:

- Receives L.MBMS information from V2X Application Server.
- Sends L.MBMS information to the MBMS-GW.

4.3.6 MBMS-GW

In addition to the functions defined in TS 23.246 [8], in case of V2X the MBMS-GW performs the following functions:

- If receiving L.MBMS information from the BM-SC, skipping the allocation procedure for IP multicast distribution, e.g., allocating an IP multicast address.

4.4 High level function

4.4.1 Authorization and Provisioning for V2X communications

4.4.1.1 Authorization and provisioning for V2X communications over PC5 reference point

4.4.1.1.1 General

The basic principles of service authorization for V2X communications over PC5 reference point:

- The UE gets authorization to use V2X communications over PC5 reference point on a per PLMN basis in the serving PLMN by the V2X Control Function in the HPLMN.
- The V2X Control Function in the HPLMN requests authorization information from the V2X Control Function of the serving PLMN.
- The V2X Control Function in the HPLMN merges authorization information from home and serving PLMNs and informs the UE of the final authorization information.
- The V2X Control Function in the VPLMN or HPLMN may revoke the authorization at any time. The V2X Control Function in the HPLMN shall be notified when authorization is revoked by the VPLMN.

4.4.1.1.2 Policy/Parameter provisioning

The following information for V2X communications over PC5 reference point is provisioned to the UE:

1) Authorization policy:

- When the UE is "served by E-UTRAN":
 - PLMNs in which the UE is authorized to perform V2X communications over PC5 reference point.
- When the UE is "not served by E-UTRAN":
 - Indicates whether the UE is authorized to perform V2X communications over PC5 reference point when "not served by E-UTRAN".

2) Radio parameters for when the UE is "not served by E-UTRAN":

- Includes the radio parameters with Geographical Area(s) and an indication of whether they are "operator managed" or "non-operator managed". These radio parameters (e.g. frequency bands) are defined in TS 36.331 [9]. The UE uses the radio parameters to perform V2X communications over PC5 reference point when "not served by E-UTRAN" only if the UE can reliably locate itself in the corresponding Geographical Area. Otherwise, the UE is not authorized to transmit.

NOTE 1: Whether a frequency band is "operator managed" or "non-operator managed" in a given Geographical Area is defined by local regulations.

3) Policy/parameters:

- The mapping of Destination Layer-2 ID(s) and the V2X services, e.g. PSID or ITS-AIDs of the V2X application.

NOTE 2: PLMN operators coordinate to make sure Destination Layer-2 ID(s) for different V2X services are configured in a consistent manner.

NOTE 3: To pre-configure a UE with the provisioning parameters, at least the "not served by E-UTRAN" parameters of 1) and 2), and the parameters of 3) need to be included.

- The mapping of ProSe Per-Packet Priority and packet delay budget for V2X communication (autonomous resources selection mode).
- The list of V2X services, e.g. PSID or ITS-AIDs of the V2X applications, with Geographical Area(s) that require privacy support.
- The mapping of service types (e.g. PSID or ITS-AIDs) to V2X frequencies (see TS 36.300 [10] for further information) with Geographical Area(s).
- The mapping of service types (e.g. PSID or ITS-AIDs) to Tx Profiles (see TS 36.300 [10] for further information).
- The list of V2X services, e.g. PSID or ITS-AIDs of the V2X applications, allowed to use a specific PPPR value.

Alternatively, the above parameters in 2) and 3) may be configured on the UE through the V1 reference point from the V2X Application Server. The V2X Control Function may also obtain these parameters through the V2 reference point from the V2X Application Server.

The parameters provisioned by the V2X Control Function take precedence over the configured parameters on the UE.

NOTE 4: The V2 reference point procedure is not specified in this Release.

4.4.1.1.3 Principles for applying parameters for V2X communications over PC5 reference point

For V2X communication over PC5, the operator may pre-configure the UEs with the required provisioning parameters for V2X Communication, without the need for the UEs to connect to the V2X Control Function to get this initial configuration. The following apply:

- The provisioning parameters for V2X communications over PC5 may be configured in the UICC, in the ME, or in both the UICC and the ME.
- The ME provisioning parameters shall not be erased when a USIM is deselected or replaced.
- If both the UICC and the ME contain the same set of provisioning parameters, the set of parameters from the UICC shall take precedence.
- The UE shall use radio resources for V2X communications over PC5 reference point as follows:
 - While a UE has a serving cell and is camped on a cell and the UE intends to use for V2X service the radio resources (i.e. carrier frequency) operated by this cell, then the UE shall use the radio resource description indicated by this cell the UE is camped on and ignore any radio resource description of the same radio resource provisioned in the ME or the UICC. If the cell does not provide radio resources for V2X service, the UE shall not perform V2X message transmission and reception on radio resources operated by this cell.
 - If the UE intends to use "operator-managed" radio resources (i.e. carrier frequency) for V2X service that are not operated by the UE's serving cell, as specified in clause 4.4.1.1.2, or if the UE is out of coverage, the UE shall search for a cell in any PLMN that is operating the provisioned radio resources (i.e. carrier frequency) as defined in TS 36.300 [10] and TS 36.304 [22], and:
 - If the UE finds such cell in the registered PLMN or a PLMN equivalent to the registered PLMN, and authorization for V2X communications over PC5 reference point to this PLMN is confirmed, the UE shall use the radio resource description indicated by that cell. If that cell does not provide radio resources for V2X service, the UE shall not perform V2X message transmission and reception on those radio resources.
 - If the UE finds such cell but not in the registered PLMN or a PLMN equivalent to the registered PLMN, and that cell belongs to a PLMN authorized for V2X communications over PC5 reference point and provides radio resources for V2X service then the UE shall perform PLMN selection triggered by V2X communications over PC5 reference point as defined in TS 23.122 [23]. If the UE has an active emergency PDN Connection, it shall not trigger any PLMN selection due to V2X communication over PC5 reference point.
 - If the UE finds such cell but not in a PLMN authorized for V2X communications over PC5 reference point the UE shall not use V2X communications over PC5 reference point.
 - If the UE does not find any such cell in any PLMN, then the UE shall consider itself "not served by E-UTRAN" and use radio resources provisioned in the ME or the UICC. If no such provision exists in the ME or the UICC or the provision does not authorize V2X communications over PC5 reference point then the UE is not authorized to transmit.
 - If the UE intends to use "non-operator-managed" radio resources (i.e. carrier frequency) for V2X service, according to TS 36.331 [9] and as specified in clause 4.4.1.1.2, then the UE shall perform V2X communication over PC5 using resource provisioned in the ME or the UICC. If no such provision exists in the ME or the UICC or the provision does not authorize V2X communications over PC5 reference point then the UE is not authorized to transmit.
- The UE provisioning shall support setting Geographical Areas.

NOTE 1: It is possible for a UE to use other radio resources for V2X service based on the Geographical Area instead of those operated by the serving E-UTRAN cell, when provisioned in the UE, even if the UE's serving cell offers normal service and the SIB21 indicates that the service (V2X communication) is available. This is to cover the scenario when e.g. the radio resources used for V2X communications over PC5 reference point are not owned by the serving network of the UE.

NOTE 2: When cross-carrier operation is supported, according to TS 36.331 [9], a UE can be instructed by its serving cell to perform V2X communication over a different carrier frequency. The UE is still considered as "served by E-UTRAN" in this case.

NOTE 3: The scenario that a cell is detected and the cell does not provide support for V2X communications over PC5 reference point when the UE attempts to use a carrier frequency configured for V2X communications over PC5 reference point, is considered a configuration error. Therefore the UE does not transmit on that frequency to avoid interference to the network.

- The V2X communications over PC5 reference point is only specified for E-UTRA.

NOTE 4: It is out of scope of the present specification to define how the UE can locate itself in a specific Geographical Area. When the UE is in coverage of a 3GPP RAT, it can for example, use information derived from the serving PLMN. When the UE is not in coverage of a 3GPP RAT, it can use other techniques, e.g. Global Navigation Satellite System (GNSS). User provided location is not a valid input.

4.4.1.2 Authorization and provisioning for V2X communications over LTE-Uu reference point

4.4.1.2.1 General

Additional information may be provisioned to the UE for the use of V2X communications over LTE-Uu reference point, e.g. for unicast or MBMS.

NOTE: A single V2X Application Server can support multiple V2X applications.

4.4.1.2.2 Policy/Parameter provisioning

The following information may be configured in V2X Control Function and optionally provisioned to the UE for V2X communications over LTE-Uu reference point:

- 1) PLMNs in which the UE is authorized to use MBMS based V2X communication.
 - Corresponding V2X USD(s) for receiving MBMS based V2X traffic in the PLMN. The V2X USD(s) may be obtained through the V2 reference point from the V2X Application Server.
- NOTE: The V2 reference point procedure is not specified in this Release.
- 2) V2X Application Server address information.
 - List of FQDNs or IP addresses of the V2X Application Servers, associated with served geographical area information and list of PLMNs that the configuration applies to.
- 3) V2X Application Server discovery using MBMS.
 - List of PLMNs and corresponding V2X Server USDs for receiving V2X Application Server information via MBMS.
- 4) Mapping of the V2X services, e.g. PSID or ITS-AIDs of the V2X application to:
 - V2X Application Server address (consisting of IP address/FQDN and UDP port) for unicast;
 - V2X USD for MBMS.

Information of the V2X USD is described in clause 4.4.7.2 and information of the V2X Server USD is described in clause 4.4.7.3.

4.4.2 V2X message transmission/reception over PC5 reference point

PC5 reference point as defined in TS 23.303 [5] is used for the transmission and reception of V2X messages. The V2X communication over PC5 reference point supports roaming and inter-PLMN operations. V2X communication over PC5 reference point is supported when the UE is "served by E-UTRAN" and when the UE is "not served by E-UTRAN".

A UE is authorized to transmit and receive V2X messages by the V2X Control Function in its home PLMN as described in clause 5.2.

The V2X communication over PC5 reference point is a type of ProSe Direct Communication with the following characteristics:

- The V2X communication over PC5 reference point is connectionless, and there is no signalling over PC5 control plane for connection establishment.
- V2X messages are exchanged between UEs over PC5 user plane.
- Both IP based and non-IP based V2X messages are supported.
- For IP based V2X messages, only IPv6 is used. IPv4 is not supported in this release.

The identifiers used in the V2X communication over PC5 reference point are described in clause 4.5.1. UE decides on the Tx Profile to use for the transmission of a particular packets based on the configuration described in clause 4.4.1.1.2.

If the UE has an active emergency PDN connection, the communication over the emergency PDN connection shall be prioritized over V2X communication over PC5 reference point.

NOTE: The emergency PDN connection setup is based on appropriate regional/national regulatory requirements and operator policies as defined in TS 23.401 [6].

4.4.3 V2X message transmission/reception over LTE-Uu reference point

4.4.3.1 General

The LTE-Uu reference point is used for the transmission and reception of V2X messages. The V2X message transmission and reception via unicast is described in clause 4.4.3.2, while the V2X message reception via MBMS is described in clause 4.4.3.3.

4.4.3.2 V2X message transmission/reception via unicast

The V2X communication via unicast over the LTE-Uu reference point supports roaming operations. Latency reduction for V2X message transfer via unicast may be achieved by using SIPTO@LN or SIPTO above RAN as defined in TS 23.401 [6].

NOTE 1: In case of SIPTO@LN with L-GW function collocated with an eNB, mobility is not supported.

For transport of IP based or non-IP based V2X messages using uplink unicast V2X communication in case of applications identified by PSID or ITS-AID for the same applications as over PC5 reference point:

- V2X messages are transported over UDP/IP packets;

NOTE 2: UDP is selected since it has shorter latency due to no connection setup, and since IP multicast works with UDP only.

- the UE sends a V2X message over UDP/IP to a V2X Application Server address. The destined V2X Application Server address is derived from the PSID (or the ITS-AID) and the UE configuration as described in clause 4.4.1.2.2; and
- the V2X Application Server receives the V2X message in a UDP/IP packet on a V2X Application Server address.

For transport of V2X messages:

- for applications different from the applications with PSID or ITS-AID for PC5 reference point, or
- for configured applications with PSID or ITS-AID sending IP based V2X messages,

existing unicast routing towards application server applies.

NOTE 3: In case V2X application uses TCP transport then existing unicast routing towards application server applies, i.e. no UDP encapsulation performed.

4.4.3.3 V2X message reception via MBMS

V2X messages can be broadcasted via MBMS in which the V2X Application Server transfers V2X messages via MBMS bearer service(s) as shown in Figure 4.2.2-1a.

For MBMS reception of V2X messages, V2X USD per PLMN for V2X services is required for the UE. The UE is provisioned with mapping of PSID (or ITS-AID) and V2X USD as described in clause 4.4.1.2.2.

To provide the UE with the V2X USD(s), the following ways may be used:

- Existing MBMS service announcement mechanisms specified in TS 23.246 [8] and TS 26.346 [11].
- Provisioning as described in clause 4.4.1.2.2, i.e. pre-configuration in the UE and/or configuration from V2X Control Function.
- Provisioning from the V2X Application Server via V1 reference point.

NOTE 1: The UE can receive the downlink broadcast from the PLMN other than Serving PLMN based on the V2X USD(s) obtained as described in this clause.

NOTE 2: The operator can configure multiple MBMS Service Areas for a specific V2X service. If any of these MBMS Service Areas overlap, the UE needs to be configured with different TMGIs for these overlapping MBMS Service Areas for this V2X service.

The V2X Application Server providing the V2X service identified by the PSID (or the ITS-AID) sends the V2X message via UDP/IP transport using information provided in the V2X USD.

For latency improvements for MBMS, localized MBMS can be considered for localized routing of V2X messages destined to UEs. Some localized MBMS deployment options are described in Annex B.

4.4.4 V2X Application Server discovery

4.4.4.1 General

A UE needs to discover the V2X Application Server(s), when V2X communication over LTE-Uu operation mode is used. The V2X Application Server address information may be configured on the UE or provisioned via V3 interface, as specified in clause 4.4.1.2.2.

When the configuration contains the FQDN(s), the UE shall perform DNS to resolve the address(es) of the V2X Application Server. The UE may use the configured V2X Application Server information only in the designated geographical area. When the UE changes serving PLMN or crosses configured geographic areas, it should perform address resolution again.

For a network that has deployed broadcast mechanisms, e.g. MBMS, additional information to assist V2X Application Server discovery can be provided via the MBMS broadcast channel. When a UE has the configuration for receiving V2X Application Server information via MBMS, as specified in clause 4.4.1.2.2, it can perform the procedures specified in clause 5.4.1 to obtain additional local V2X Application Server information. The local V2X Application Server information obtained by MBMS as described in clause 5.4.1 takes precedence over the V2X Application Server information in the UE.

4.4.4.2 Multiple V2X Application Server and Localized V2X Application Server discovery and routing

Multiple V2X Application Servers may be involved in the V2X communication, each providing particular V2X services and/or serving a particular geographical region. Therefore, the V2X Application Server address information as specified in clause 4.4.1.2.2 can contain multiple servers' information. When multiple V2X Application Servers are configured, the application layer will choose the proper V2X Application Server to use.

When localized V2X Application Servers are deployed, Anycast may be used to conceal the server change from the UE. In this case, a FQDN is configured for a large region, e.g. the entire PLMN, and the UE only needs to resolve it once to an Anycast address. The PDN GW or LGW is responsible for routing the traffic to the appropriate local V2X Application Servers based on Anycast address.

4.4.5 QoS handling for V2X communication

4.4.5.1 QoS handling for V2X communication over PC5 reference point

Core Network, i.e. MME, provides the UE-PC5-AMBR based on subscription information to the eNB as part of the UE context information.

When PC5 is used for the transmission of V2X messages, the following principles are followed for both network scheduled operation mode and UE autonomous resources selection mode:

- ProSe Per-Packet Priority (PPPP) defined in clause 5.4.6.1 of TS 23.303 [5] applies to the V2X communication over PC5.
- ProSe Per-Packet Reliability (PPPR) applies to the V2X communication over PC5 as defined in TS 23.303 [5]. PPPR has a value range of 1 to 8, where the higher value represents the lower reliability requirement for that message. The UE may be configured with a list of V2X services, e.g. PSID or ITS-AIDs allowed to use the specific PPPR value.
- The application layer sets the PPPP for each V2X message when passing it to lower layer for transmission.
- The application layer may set the PPPR for each V2X message when passing it to lower layer for transmission.
- The mapping of application layer V2X message priority to PPPP is configuration on the UE.
- The mapping of application layer V2X message reliability to PPPR is configuration on the UE.
- The setting of the PPPP value should reflect the latency required in both UE and eNB, i.e. the low PDB is mapped to the high priority PPPP value.
- The mapping between V2X service types and V2X frequencies is as defined in clause 4.3.2 and clause 4.4.1.1.2.
- The mapping of Destination Layer-2 ID(s) and the V2X services, e.g. PSID or ITS-AIDs of the V2X application is as described in clause 4.4.1.1.2.

NOTE: The mapping of PPPP to packet delay budget is not specified in this specification.

When the network scheduled operation mode is used, following additional principles apply:

- UE provides priority information reflecting PPPP to the eNB for resources request.
- When the eNB receives a request for PC5 resource from a UE, the eNB can deduce the packet delay budget from the priority information reflecting PPPP from the UE.
- eNB can use the priority information reflecting PPPP for priority handling and UE-PC5-AMBR for capping the UE PC5 transmission in the resources management.
- UE may provide PPPR information reflecting reliability requirement described in TS 22.186 [28] to the eNB for resources request.
- UE provides Destination Layer-2 ID(s) of the V2X services to the eNB for resources requested as defined in TS 36.321 [26].
- When the eNB receives a request for PC5 resource from a UE, the eNB determines the V2X frequency(ies) in which the V2X service is to be scheduled as defined in TS 36.300 [10].

When the autonomous resources selection mode is used, following additional principle applies:

- The UE derives the packet delay budget of the V2X message from PPPP based on the provisioned mapping information described in clause 4.4.1.1.2.
- The UE derives the frequency in which a V2X service is to be transmitted, from the mapping between V2X service types and V2X frequencies as described in clause 4.4.1.1.2.

4.4.5.2 QoS handling for V2X communication over LTE-Uu reference point

The V2X messages can be delivered via Non-GBR bearer as well as GBR bearer.

The following standardized QCI values defined in TS 23.203 [12] can be used:

- QCI 3 and QCI 79 can be used for the unicast delivery of V2X messages;
- QCI 75 is only used for the delivery of V2X messages over MBMS bearers.

4.4.6 Subscription to V2X services

The user's profile in the HSS contains the subscription information to give the user permission to use V2X services.

At any time, the operator can remove the UE subscription rights for V2X services from user's profile in the HSS, and revoke the user's permission to use V2X services.

The following subscription information is defined for V2X services:

- a) whether the UE is authorized to perform V2X communication over PC5 reference point as Vehicle UE, Pedestrian UE, or both.
- b) UE-PC5-AMBR for V2X communication over PC5 reference point.
- c) the list of the PLMNs where the UE is authorized to perform V2X communication over PC5 reference point.

The HSS provides a) and b) to MME as subscription information and the MME provides a) and b) to eNB as part of the UE context information.

The HSS provides c) to V2X Control Function.

4.4.7 MBMS bearer announcement for V2X use

4.4.7.1 General

MBMS bearer announcements are needed for V2X message reception via MBMS as defined in clause 4.4.3.3, or V2X Application Server discovery via MBMS as defined in clauses 4.4.4.1 and 5.4.1.

The method for delivering the per PLMN configuration to the UE is specified in clause 4.4.3.3. The announced service information for V2X use should follow the guidance in clauses 4.4.7.2 and 4.4.7.3.

4.4.7.2 User Service Description for V2X Communication (V2X USD)

As the V2X Application Server is out of scope of 3GPP, the exact information to be included in the V2X USD cannot be controlled. However, the V2X Application Server should make sure that the information listed in table 4.4.7.2-1 is included in the V2X USD it provides.

The V2X message formats are handled by upper layer via Session Description Protocol (SDP).

Table 4.4.7.2-1: Information for V2X USD

Information element	Description
TMGI	TMGI information
List of service area identifier	A list of service area identifier for the applicable MBMS broadcast area.
Frequency	Identification of frequency if multi carrier support is provided
SDP information (NOTE 1)	SDP with IP multicast address and port number used for V2X communication via MBMS. Depending on the V2X application, the V2X message can be carried directly on top of UDP, without any streaming protocols.
NOTE 1: Typical V2X application does not require Codec information in the SDP information.	

4.4.7.3 User Service Description for V2X Application Server Discovery (V2X Server USD)

The V2X Server USD is used to configure the UE for receiving local V2X Application Server information when it is provided over MBMS, as specified in clause 5.4.1.

The local Service Information contained in the broadcast is as described in clause 5.4.1.2, and should include similar information defined in clause 4.4.1.2.2.

NOTE: Stage 3 defines the format of the local Service information.

Table 4.4.7.3-1: Information for V2X Server USD

Information element	Description
TMGI	TMGI information
List of service area identifier	A list of service area identifier for the applicable MBMS broadcast area.
Frequency	Identification of frequency if multi carrier support is provided
SDP information	SDP with IP multicast address and port number used for V2X Application Server discovery via MBMS. The content of the message carries the local Service Information and should include following information: <ul style="list-style-type: none"> - Mapping of the V2X services, e.g. PSID or ITS-AIDs of the V2X application of a PSID and ITS-AID to V2X Application Server address (consisting of IP address/FQDN and UDP port) for unicast, and V2X USD for V2X communication via MBMS.

4.4.8 Support for V2X communication for UEs in limited service state

For UE in limited service state, only V2X communication over PC5 is allowed.

UEs that are authorized to use V2X communication over PC5 reference point shall be able to use V2X communication over PC5 reference point when in limited service state following the principles defined in clause 4.4.1.1.3 for V2X communication over PC5 reference point when the UE enters in limited service state:

- because it cannot find a suitable cell of the selected PLMN as described in TS 23.122 [23] or
- as the result of receiving one of the following reject reasons defined in TS 23.122 [23]:
 - a "PLMN not allowed" response to a registration request or;
 - a "GPRS not allowed" response to a registration request

A UE in limited service state shall only use the radio resources and procedure available in ECM-IDLE mode for V2X communication over PC5 reference point, for details see TS 36.300 [10].

UEs shall not use V2X communication over PC5 reference point using the "operator-managed" radio resources, as specified in clause 4.4.1.1.2, if the UE has entered in limited service state due to all other situations (e.g. no SIM in the MS, an "illegal MS" or "illegal ME" response to a registration request, or an "IMSI unknown in HLR" response to a registration request) defined in TS 23.122 [23], where the UE is unable to obtain normal service from a PLMN. The UEs may use V2X communication over PC5 reference point using the "non-operator-managed" radio resources, as specified in clause 4.4.1.1.2, according to the principles defined in clause 4.4.1.1.3.

4.4.9 Charging support for V2X communication

4.4.9.1 Charging support for V2X communication over PC5 reference point

For V2X communication over PC5, the mechanism defined in TS 32.277 [18] for ProSe Direct Communication can be reused for charging support. No enhancement to charging support for V2X communication over PC5 is specified in this Release.

4.4.9.2 Charging support for V2X communication over LTE-Uu reference point

For V2X communication over LTE-Uu, there are unicast traffic and/or MBMS based broadcast traffic.

For unicast V2X communication, charging is provided with the existing unicast communication mechanism as specified in TS 32.251 [20] where applicable.

For MBMS based broadcast traffic, charging is provided with the existing mechanism as specified in TS 32.273 [21] where applicable.

No enhancement to charging support for V2X communication over LTE-Uu is specified in this Release.

4.4.10 Security and privacy protection support for V2X communication

The security for the V3 and PC5 reference points is provided with mechanisms defined in TS 33.185 [25].

The security and privacy protection for the PC5 based V2X communication is provided by application layer schemes developed in other SDOs. In addition, the V2X layer also provides an additional mechanism to change Layer-2 ID and source IP address to protect privacy, as described in clause 4.5.1.

The security of LTE-Uu based V2X communication reuses existing EPS security. No privacy enhancement for V2X communication over LTE-Uu is specified for this release.

Details of security and privacy protection mechanisms for V2X communication over PC5 or LTE-Uu reference points are defined in TS 33.185 [25].

4.5 Identifiers

4.5.1 Identifiers for V2X communication over PC5 reference point

Each UE has a Layer-2 ID for the V2X communication over PC5 reference point, which is included in the source Layer-2 ID field of every frame that it sends on the layer-2 link. The UE self-assigns the Layer-2 ID for the V2X communication over PC5 reference point.

When IP based V2X messages are supported, the UE auto-configures a link local IPv6 address to be used as the source IP address, as defined in clause 4.5.3 of TS 23.303 [5]. The UE may use the auto-configured link local IP address for V2X communication over PC5 reference point without sending Neighbor Solicitation and Neighbor Advertisement message for Duplicate Address Detection.

If the UE has an active V2X application that requires privacy support in the current Geographical Area, as identified by configuration described in clause 4.4.1.1.2, in order to ensure that a source UE (e.g. vehicle) cannot be tracked or identified by any other UEs (e.g. vehicles) beyond a certain short time-period required by the application, the source Layer-2 ID must be changed over time and randomized. For IP based V2X communication over PC5 reference point, the source IP address must be also changed over time and randomized. The change of the identifiers of a source UE must be synchronized across layers used for PC5, e.g. when application layer identifier changes, the source Layer-2 ID and the source IP address need to be changed.

The UE is configured with the destination Layer-2 ID(s) to be used for V2X services. The Layer-2 ID for a V2X message is selected based on the configuration as described in clause 4.4.1.1.

5 Functional description and information flows

5.1 Control and user plane stacks

5.1.1 User plane for PC5 reference point supporting V2X services

The PC5-U stack as defined in clause 5.1.2.1 of TS 23.303 [5] is used for the V2X communication over PC5 reference point. IP and Non-IP PDCP SDU types are supported for the V2X communication over PC5.

For IP PDCP SDU type, only IPv6 is supported. The IP address allocation and configuration are as defined in clause 4.5.1.

The Non-IP PDCP SDU contains a Non-IP Type header, which indicates the V2X message family used by the application layer, e.g. IEEE 1609 family's WSMP [13], ISO defined FNTP [14], etc.

NOTE: The Non-IP Type header and allowed values are defined in TS 24.386 [27].

5.2 Service authorization and update for V2X communications

5.2.1 Service authorization procedures

The service authorization procedures as specified in clause 5.2.1 of TS 23.303 [5] are reused for the authorization of a UE for V2X communications, with the V2X Control Functions in the corresponding PLMNs acting as the ProSe Functions.

5.2.2 Service authorization update procedures

The service authorization update procedures as specified in clause 5.2.2 of TS 23.303 [5] are reused for the updating of service authorization information in the UE.

5.3 Procedure for V2X communication over PC5 reference point

To perform V2X communication over PC5 reference point, the UE is configured with the related information as described in clause 4.4.1.1.

The procedure for one-to-many ProSe Direct Communication transmission described in clause 5.4.2 of TS 23.303 [5] is applied to V2X communication over PC5 reference point with following differences:

- The source Layer-2 ID is set to the Layer-2 ID described in clause 4.5.1.
- A UE shall be configured with a set of Layer-2 ID corresponding to different type of services.
- A UE shall be configured with the mapping of services types to Tx Profiles as described in clause 4.4.1.1.2, and selects a Tx Profile to use based on the upper layer provided service type (PSID/ITS-AID).

The procedure for one-to-many ProSe Direct Communication reception described in clause 5.4.3 of TS 23.303 [5] is applied to V2X communication over PC5 reference point.

5.4 Procedure for V2X communication over LTE-Uu reference point

5.4.1 V2X Application Server discovery using MBMS

5.4.1.1 General

This procedure is applicable for local V2X Application Server discovery if supported by the network. It may be used by the UE only when it is configured with the information to receive V2X Application Server information via MBMS, as specified in clause 4.4.1.2.2.

5.4.1.2 Procedures for receiving V2X Application Server information via MBMS

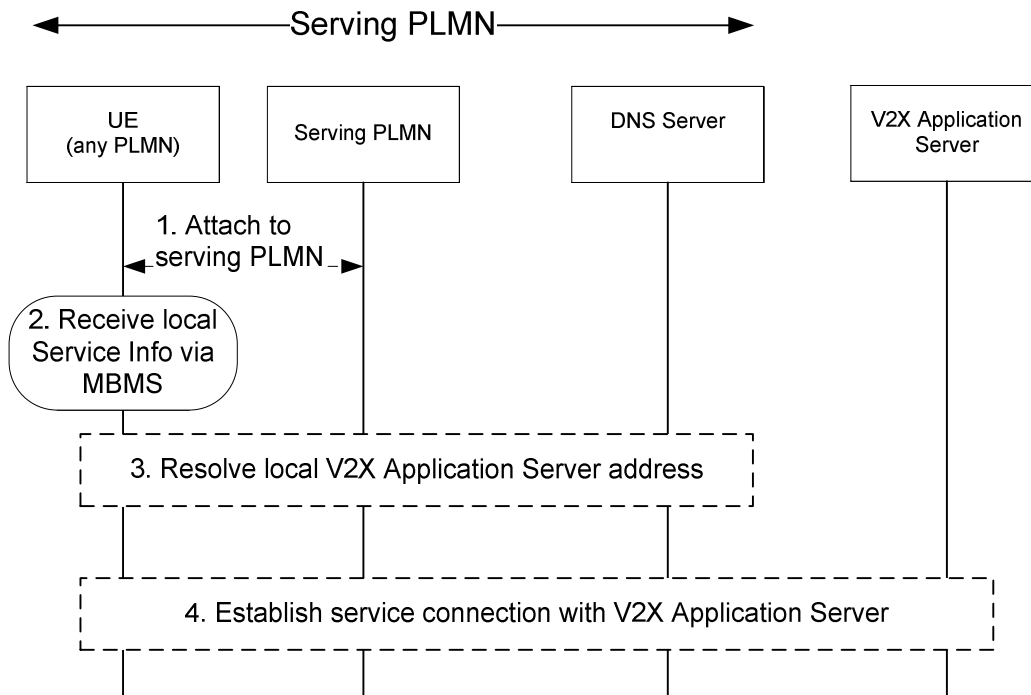

Figure 5.4.1.2-1: V2X Application Server discovery using broadcast

1. When a UE desires V2X communications via LTE-Uu, it attaches to the serving PLMN if it has not done so.
2. If the UE has configuration for receiving V2X Application Server information via MBMS, as specified in clause 4.4.1.2.2, it receives the local Service Information from the corresponding broadcast traffic channel. The local Service Information includes the address information of the local V2X Application Servers, e.g. the FQDNs of the servers. In addition, the local Service Information may include the V2X USD for the corresponding V2X Application Servers, if MBMS downlink is to be used.

NOTE: The UE can be in MBMS receive only mode for obtaining the local Service Information.

3. Based on the information received from step 2, the UE obtains the local V2X Application Server address, e.g. via a query of the DNS with the received FQDN.
4. The UE may establish connection with the V2X Application Server for the service, e.g. obtaining the V2X USD if it is not provided in step 2 to allow the UE to receive V2X messages over MBMS.

5.4.2 Procedure for V2X communication with MBMS

5.4.2.1 MBMS service area mapping

5.4.2.1.1 General

MBMS service areas for V2X services may be configured at the V2X Application Server. Such service areas are not expected to change frequently. V2X Application Server performs the following procedures for managing the MBMS sessions:

- MBMS bearer activation/deactivation procedures specified in TS 23.468 [7] and clause 5.4.2.2 are used for managing MBMS sessions. V2X Application Server acting as the GCS AS uses the configured MBMS Service Area Identities (SAIs) and/or list of Cell IDs (ECGIs) of the target broadcast area for such procedures.

- If the UE provides its geographic location or Cell ID information over V1 reference point, the V2X Application Server may use such information for the determination of the target broadcast area (e.g. MBMS SAI(s) and/or ECGI(s)) for the downlink broadcast of V2X messages.
- From such procedures, the V2X Application Server knows which TMGI/Flow-ID (i.e. MBMS session) is serving a geographical area. Hence, V2X Application Server forwards a V2X message to the appropriate MBMS session.

NOTE: V2X messages may be broadcasted to an area larger than needed. The V2X application in the UE discards the messages that are not relevant to the UE based on procedures internal to the UE.

5.4.2.1.2 Functional Description

V2X Application Server shall map UE provided location information to a form that is understood by the 3GPP MBMS system, e.g. MBMS SAI(s) and/or ECGI(s).

A UE may include its geographic location information in the V2X message, e.g. as defined ETSI ITS (ETSI TS 102 637-2 [16], ETSI TS 102 637-3 [17]) or other ITS specifications. The V2X Application Server shall provide the MBMS broadcast area parameters to BM-SC and BM-SC process the MBMS broadcast area parameters as defined in TS 23.468 [7].

Additionally, a UE may provide its geographic location information in the V2X message and Cell ID (i.e. ECGI) information in the signalling to the V2X Application Server. The V2X Application Server may use such information for determining the target MBMS broadcast area as defined in TS 23.468 [7].

The BM-SC derives the MBMS Service Area and the SAI list for the availability information from Geographical Area as provided by the V2X Application Server as defined in TS 26.346 [11] when using xMB interface.

NOTE: As specified in TS 23.246 [8], the BM-SC provides both the MBMS SAI(s) and Cell ID(s) towards the downlink signalling path towards the RAN nodes.

5.4.2.2 Local MBMS based MBMS data delivery

For MBMS latency improvements, the V2X Application Server may provide the BM-SC with L.MBMS (Local MBMS) information, i.e., M1 interface information including transport network IP Multicast Address, IP address of multicast source and C-TEID, as well as MB2-U interface information including IP address and UDP port number for the user plane. This L.MBMS information is preconfigured in the V2X Application Server.

Figure 5.4.2.2-1 shows the procedure that the L.MBMS information (both M1 interface information and MB2-U interface information) is provided from the V2X Application Server to the BM-SC, and in turn M1 interface information is provided from BM-SC to MBMS-GW when activating MBMS bearer and V2X message is delivered per the provided L.MBMS information.

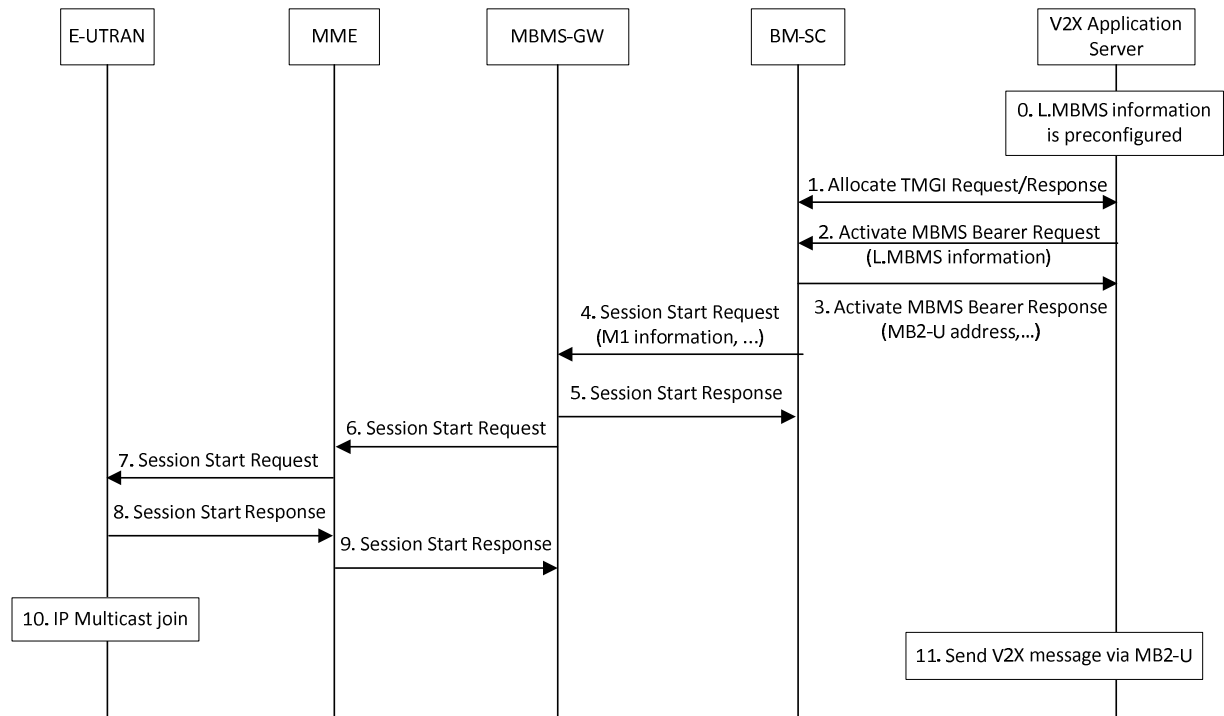

Figure 5.4.2.2-1: L.MBMS based MBMS data delivery

0. The L.MBMS information is preconfigured in the V2X Application Server.

1. The V2X Application Server performs the TMGI Allocation procedure as specified in TS 23.468 [7].

2-3. Steps 2 and 3 are similar to in clause 5.1.2.3.2 of TS 23.468 [7], with the following differences:

- In step 2, the V2X Application Server includes L.MBMS information in an Activate MBMS Bearer Request message. The L.MBMS information is preconfigured in the V2X Application Server.
- In step 3, if the BM-SC uses the L.MBMS information from the V2X Application Server then it copies the MB2-U interface information received from step 2 as MB2-U address (i.e., "BM-SC IP address and port number for the user-plane" information element) in the Activate MBMS Bearer Response message to the V2X Application Server.

4-5. Steps 4 and 5 are similar to in clause 8.3.2 of TS 23.246 [8], with the following differences:

- In step 4, the BM-SC includes the M1 interface information of the L.MBMS information received from the V2X Application Server in the Session Start Request message if the BM-SC decided to use the L.MBMS information.
- In steps 4 and 5, if the MBMS-GW uses the M1 interface information received from the BM-SC then it skips the allocation procedure for IP multicast distribution, e.g. allocate an IP multicast address.

6-10. Same to steps 3 to 6 and step 8 in clause 8.3.2 of TS 23.246 [8].

11. The V2X Application Server sends V2X message to the L.MBMS's IP address via MB2-U.

If BM-SC does not use L.MBMS information received from V2X Application Server, then BM-SC allocates the addresses related to MB2-U interface as currently specified in TS 23.468 [7]. V2X Application Server is aware that the BM-SC is not using L.MBMS information when the MB2-U address received from step 3 is different than the one in the L.MBMS information provided in step 2. In this case, V2X Application Server shall continue with procedure as defined in TS 23.468 [7].

The L.MBMS support using xMB interface requires same information to be provided via xMB-C using Service Management Procedures as defined in TS 26.346 [11]. For MBMS latency improvements, the V2X Application Server may provide the BM-SC with L.MBMS (Local MBMS) information, i.e., M1 interface information including transport network IP Multicast Address, IP address of multicast source and C-TEID, as well as xMB-U interface information

including IP address and UDP port number for the user plane. This L.MBMS information is preconfigured in the V2X Application Server.

5.5 V2X impacts to EPC procedures

5.5.1 E-UTRAN attach procedure for UE

The E-UTRAN attach procedure for UE is performed as defined in TS 23.401 [6] with the following additions:

- The UE includes the V2X capability indication as part of the "UE Network Capability" in the Attach Request message. The MME stores this information for V2X operation. The V2X capability can indicate whether the UE is capable of supporting V2X communication over PC5 reference point.
- If the UE indicated V2X capability, and the UE is authorized to use V2X communication over PC5 reference point based on the subscription data, then the MME shall include a "V2X services authorized" indication in the S1-AP Initial Context Setup Request, indicating the UE is authorized to use V2X communication over PC5 reference point as Vehicle UE, Pedestrian UE or both.
- The MME obtains the UE-PC5-AMBR from the HSS as part of the subscription data and includes it in the S1-AP Initial Context Setup Request to the eNodeB, which use it in resource management of UE's PC5 transmission for V2X services in network scheduled mode.

5.5.2 Service Request procedures for UE

The Service Request procedures for UE are performed as defined in TS 23.401 [6] with the following additions:

- If the UE is V2X capable, and the UE is authorized to use V2X communication over PC5 reference point based on the subscription data, then the MME shall include a "V2X services authorized" indication in the S1-AP Initial Context Setup Request, indicating the UE is authorized to use V2X communication over PC5 reference point as Vehicle UE, Pedestrian UE or both.
- The MME includes the UE-PC5-AMBR in the S1-AP Initial Context Setup Request to the eNodeB which stores it as part of the UE context and may use it in resource management of UE's PC5 transmission for V2X services in network scheduled mode.

5.5.3 S1 Handover procedures for UE

The Intra-E-UTRAN S1-based handover or the Inter-RAT to E-UTRAN handover procedures for UE are performed as defined in TS 23.401 [6] with the following additions:

- If the UE is V2X capable, and the UE is authorized to use V2X communication over PC5 reference point based on the subscription data, then the target MME shall send the "V2X services authorized" indication and UE-PC5-AMBR to the target eNodeB as follows:
 - For the intra MME handover, the "V2X services authorized" indication and UE-PC5-AMBR are included in the S1-AP Handover Request message. If after the handover procedure, the "V2X services authorized" indication or the UE-PC5-AMBR or both are changed, the updated "V2X services authorized" indication or the updated UE-PC5-AMBR or both are included in the S1-AP UE Context Modification Request message sent to the target eNodeB.
 - For the inter MME handover or Inter-RAT handover to E-UTRAN, the "V2X services authorized" indication and UE-PC5-AMBR are included in the S1-AP UE Context Modification Request message sent to the target eNodeB after the handover procedure.

The "V2X services authorized" indication sent to target eNodeB denotes the UE is authorized to use V2X communication over PC5 reference point as Vehicle UE, Pedestrian UE or both.

5.5.4 X2 Handover procedures for UE

For the X2-based handover, the "V2X services authorized" indication and the UE-PC5-AMBR are sent to target eNodeB as follows:

- If the source eNodeB is V2X-enabled and the "V2X services authorized" indication is included in the UE context, then the source eNodeB shall include a "V2X services authorized" indication and UE-PC5-AMBR in the X2-AP Handover Request message to the target eNodeB.
- If the UE is V2X capable, and the UE is authorized to use V2X communication over PC5 reference point based on the subscription data, then the MME shall send the "V2X services authorized" indication and the UE-PC5-AMBR to the target eNodeB in the Path Switch Request Acknowledge message. If, after the handover procedure, the "V2X services authorized" indication or the UE-PC5-AMBR or both are changed, the updated "V2X services authorized" indication or the updated UE-PC5-AMBR or both are included in the S1-AP UE Context Modification Request message sent to the target eNodeB.

The "V2X services authorized" indication sent to target eNodeB denotes the UE is authorized to use V2X communication over PC5 reference point as Vehicle UE, Pedestrian UE or both.

The UE-PC5-AMBR is sent to target eNodeB for the resources management of UE's PC5 transmission in V2X communication.

5.5.5 Tracking Area Update procedure for UE

The Tracking Area Update procedures for UE are performed as defined in TS 23.401 [6] with the following additions:

- The UE includes the V2X capability indication as part of the "UE Network Capability" in the Tracking Area Update Request message. The MME stores this information for the V2X operation.
- If the MME determines to re-establish the radio and S1 bearers for all active EPS bearer contexts due to the "active" flag included in the Tracking Area Update Request message or the pending downlink data or signalling, the UE is V2X capable, and the UE is authorized to use V2X communication over PC5 reference point based on the subscription data, then the MME shall include a "V2X services authorized" indication and UE-PC5-AMBR in the S1-AP Initial Context Setup Request. The "V2X services authorized" indication sent to eNodeB denotes the UE is authorized to use V2X communication over PC5 reference point as Vehicle UE, Pedestrian UE or both.

5.5.6 Insert Subscriber Data procedure for UE

The Insert Subscriber Data procedures for UE are performed as defined in TS 23.401 [6] with the following additions:

- If the "V2X services authorized" indication or the UE-PC5-AMBR or both need to be changed due to the changed subscription data and the S1 bearer is established, then the MME shall notify the eNodeB the updated "V2X services authorized" indication or the UE-PC5-AMBR or both via the S1-AP UE Context Modification Request message.

5.5.7 Delete Subscriber Data procedure for UE

Delete Subscriber Data procedure for UE is performed as defined in TS 29.272 [15] with the same additions as in clause 5.5.6.

Annex A (informative): Road Side Unit (RSU) implementation options

This Annex presents examples how RSU can be implemented. With reference to the architectural reference models defined in clause 4.2, the RSU can receive V2X messages via SGi, PC5 or LTE-Uu interface depending on implementation option.

Figure A-1 shows a UE-type RSU, which combines a UE with the V2X application logic.

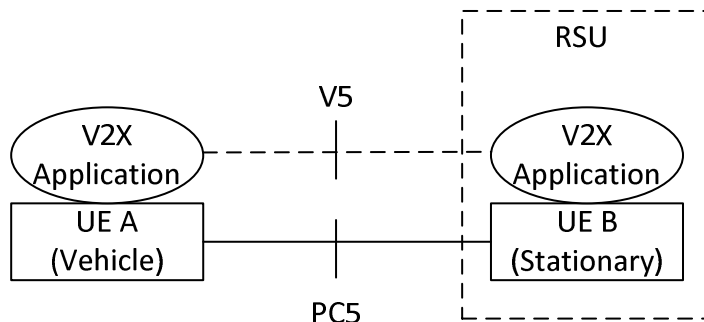

Figure A-1: RSU includes a UE and the V2X application logic

Figure A-2 shows one example of eNB-type RSUs. In this example, the RSU comprises an eNB, a collocated L-GW, and a V2X Application Server.

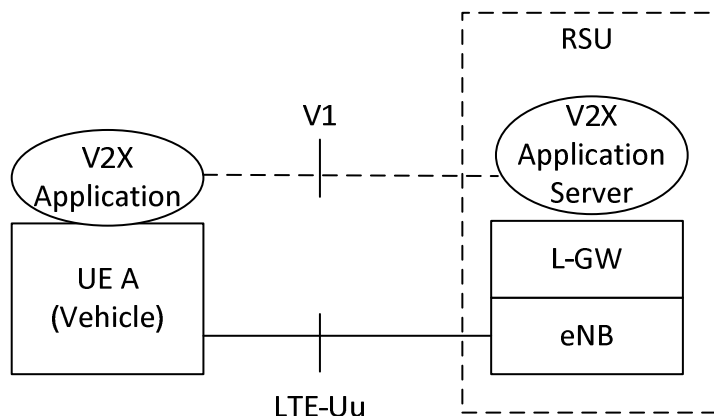

Figure A-2: RSU includes an eNB, L-GW and a V2X Application Server

Annex B (informative): Localized MBMS deployment options

B.1 General Description

In current MBMS system, the BM-SC, MBMS-GW and MME are located in the Core Network. The backhaul delay between the BM-SC and the eNB is non-negligible when calculating the end-to-end delay, especially when MBMS is used to delivery downlink V2X messages in the V2X system. To minimize the latency, possible deployment can consider the following options:

- To move the MBMS CN functions (e.g. BM-SC, MBMS-GW) closer to the eNB.
- To move the user plane of MBMS CN functions (BM-SC, MBMS-GW) closer to the eNB.

These options are illustrated in clause B.2 and clause B.3. The list of deployment options is not exhaustive and that they are shown for illustration purposes only.

If the V2X Application Server utilizes xMB interface, the options B.2 and B.3 replace MB2-C and MB2-U with xMB-C and xMB-U respectively.

B.2 Option of localized MBMS CN functions

In this case BM-SC, and MBMS-GW are located close to the eNB. This option is shown in Figure B.2-1.

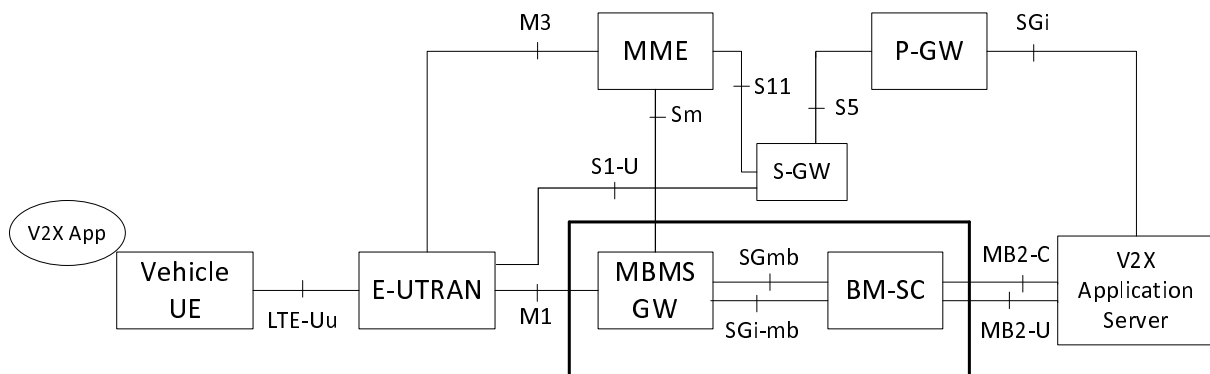

Figure B.2-1: Localized MBMS CN functions

B.3 Option of localized user plane of MBMS CN functions

In this case user plane of MBMS CN functions (BM-SC and MBMS-GW) is located close to the eNB. This option is shown in Figure B.3-1.

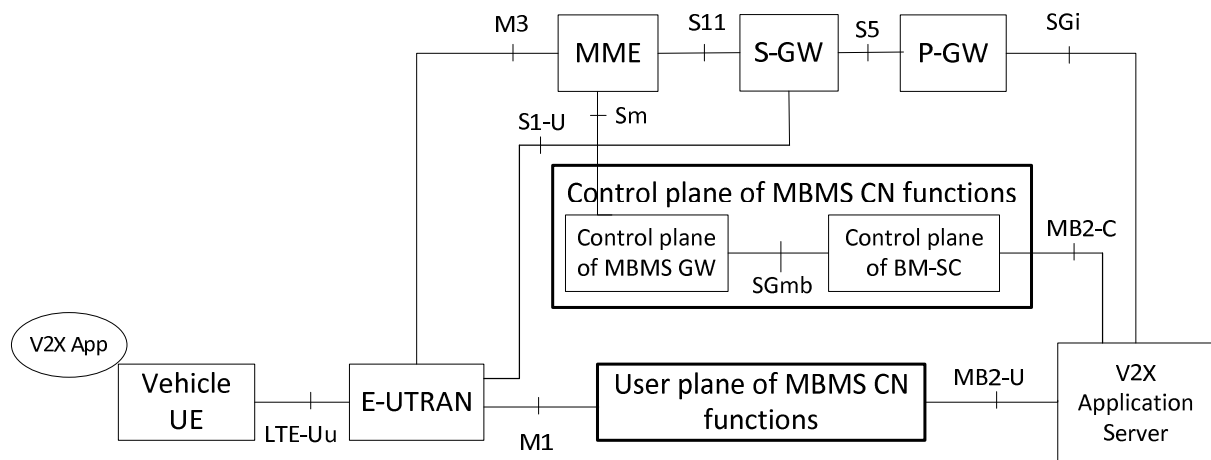

Figure B.3-1: Localized user plane of MBMS CN functions

The user plane of MBMS CN functions can implement the following user plane functionalities:

- Receive user data from V2X Application Server over MB2-U.
- IP multicast distribution of MBMS user plane data to E-UTRAN (M1 reference point).
- Data synchronization (as for the BM-SC in legacy MBMS mechanisms).
- If used, apply favourable error resilient schemes, e.g. specialized MBMS codecs or Forward Error Correction schemes.
- If used, MBMS data encryption.

The procedure for Local MBMS based MBMS data delivery described in clause 5.4.2.2 makes this type of deployment option possible to improve V2X latency.

The separation of control and user plane functions in this option is for illustration only.

Annex C (informative): Example hybrid operation modes for V2X communication over PC5 and LTE-Uu

C.1 General

This Annex presents examples on how two operation modes for V2X communication, i.e. over the PC5 and over LTE-Uu, can be used in a hybrid manner.

C.2 PC5 based V2X communication with MBMS reception

In this operation mode, a UE always transmits the V2X messages via PC5. The UE receives V2X messages via PC5 and via MBMS as well.

A stationary infrastructure entity acting as a UE, e.g. an RSU, receives V2X messages via PC5, and forwards the application layer processed V2X messages to a V2X Application Server via V1 interface, e.g. using a PDN connection over LTE-Uu or other type of connection (for example fixed). The V2X messages processed by the V2X Application Server can be distributed to UEs via the MBMS system as required.

In this manner, a UE can directly receive V2V messages from other UEs in close proximity. Additionally, in this operation mode, the mobile network provides information from an extended range and satisfies the needs of soft safety (e.g. situational awareness at range) or enables more advanced driving assistance applications. This combined sources of information are especially useful in high density use cases, where the UE may not be able to reliably receive V2X messages directly from distant UEs over PC5.

C.3 Simultaneous LTE-Uu based and PC5 based V2X communication without MBMS

In this operation mode, UEs communicate with other UEs that are in proximity, including with UE-type RSUs, via PC5 for both the transmission and reception of V2X messages. The UE-type RSUs can communicate with the V2X Application Servers in the mobile network, e.g. over LTE-Uu, as needed, for managing the communication of V2X messages beyond the direct PC5 communication range. With such hybrid use of PC5 and LTE-Uu based V2X communication, MBMS broadcast on the downlink is not needed.

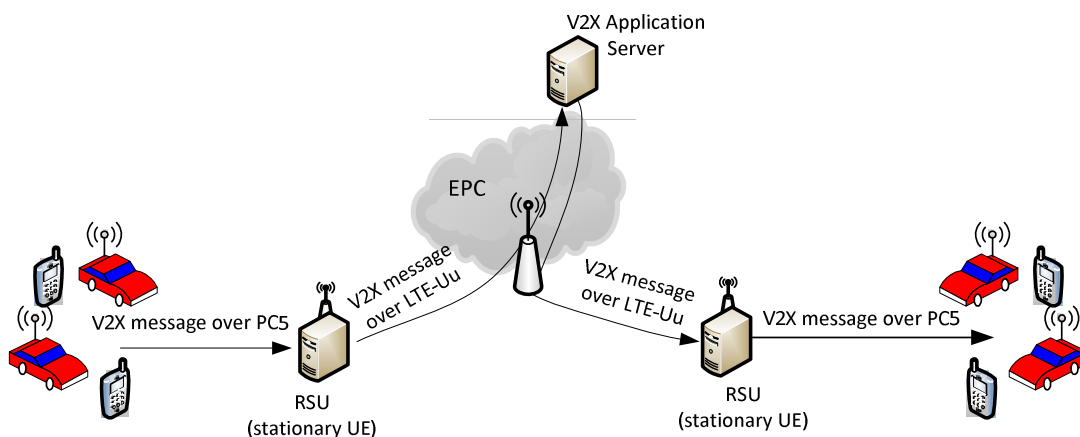

Figure C.3-1: V2X message transmission and reception using UE-type RSU via LTE-Uu and PC5

Figure C.3-1 is a high level illustration of this operation mode. This operation mode consists of three components:

- Stationary infrastructure entities acting as UEs, e.g. UE-type RSUs, are deployed to provide adequate coverage to vehicular traffic infrastructure. The UEs and the UE-type RSUs are configured or provisioned with information for V2X communication over PC5 as specified in clause 4.4.1. The UE-type RSUs may communicate with the V2X Application Servers.
- The UE-type RSUs receive V2X messages from other UEs via PC5. The V2X application of the RSU(s) decides if the messages need to be routed to the V2X Application Server(s) over LTE-Uu connection, e.g. when the target area is larger than its V2X communication range over PC5. The V2X Application Server(s) determines the target area and the size of the area where the V2X messages need to be distributed. The V2X Application Server may coordinate and communicate with other V2X Application Servers for the determination of the target area and distribution of V2X messages in the target area.
- V2X Application Server(s) send V2X messages downlink to the RSUs in the target distribution area, e.g. over LTE-Uu. The RSUs broadcast the received V2X messages using V2X communication over PC5. UEs within the region receive the RSU broadcasted V2X messages over PC5.

In this manner, a UE, e.g. vehicle UE only needs to operate in the operation mode of V2X communication over PC5, for V2V/V2P services. Only the UEs implemented as RSUs operate in the hybrid mode of simultaneous V2X communication over PC5 and LTE-Uu. Such combination of PC5 based and LTE-Uu based V2X communications is also useful in use cases where the UE may not be able to receive V2X messages directly from distant UEs via PC5. In addition, the UE-type RSUs can use SIPTO connection for the communication with local V2X Servers to reduce latency.

Annex D (informative): V2X Message Distribution Server deployment option

D.1 General Description

In the case of non-session based V2X services (i.e. Road Status Notification), it is possible that a single V2X message needs to be delivered to multiple locally relevant V2X Application Servers. In order to provide network support for the distribution of these V2X messages to multiple V2X Application Servers, a possible deployment option includes a V2X Message Distribution Server behind the L/PGW as illustrated in Figure D.1-1. It is configured to distinguish whether a V2X message needs to be delivered to multiple V2X Application Servers and send them accordingly.

UEs discover and send V2X messages to these network deployed distribution servers in the same way as to V2X Application Servers. From the UE perspective, it is communicating with a V2X Application Server and is not aware whether any of the V2X messages are further distributed onward to other servers.

NOTE: The V2X Message Distribution Server is used for illustrative purpose and not further described in any 3GPP specification.

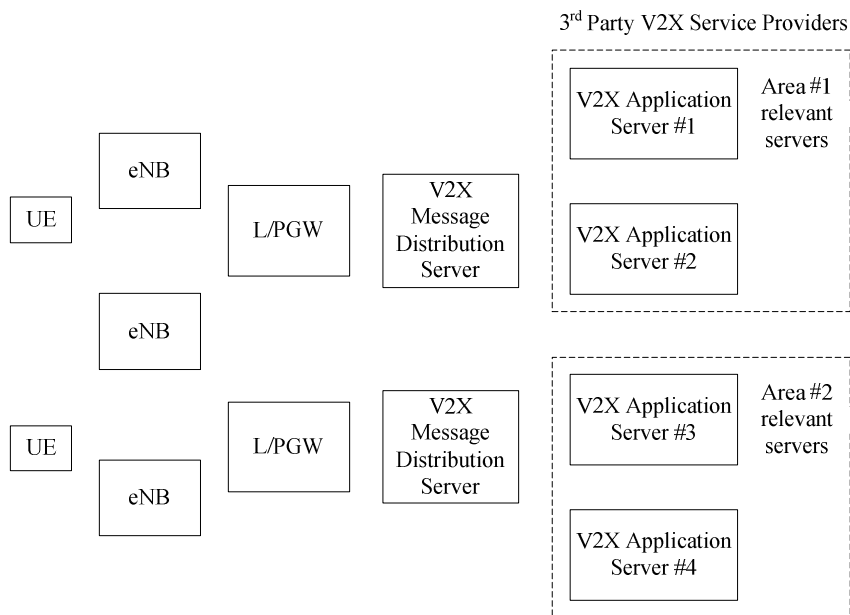

Figure D.1-1: V2X message distribution server deployment option

Annex E (informative): Change history

Change history							
Date	Meeting	TDoc	CR	Rev	Cat	Subject/Comment	New version
2016-09	SP-73	SP-160663	-	-	-	Editorial clean up for presentation to TSG SA#73 for information. This version also presented to TSG SA#73 for approval in SP-160626	1.0.0
2016-09	SP-73	-	-	-	-	Editorial clean up for publication after TSG SA#73 Approval	14.0.0
2016-12	SP-74	SP-160814	0001	2	F	V2X message handling over LTE Uu	14.1.0
2016-12	SP-74	SP-160814	0003	1	B	Update of V2X impacts to EPC procedures	14.1.0
2016-12	SP-74	SP-160814	0004	1	B	Mapping between PPPP and latency for autonomous resources selection mode	14.1.0
2016-12	SP-74	SP-160814	0005	2	F	Update of Functional entities description	14.1.0
2016-12	SP-74	SP-160814	0006	1	B	Subscription to V2X services	14.1.0
2016-12	SP-74	SP-160814	0007	-	F	Clarification on MBMS for LTE-Uu based V2X architecture reference model	14.1.0
2016-12	SP-74	SP-160814	0009	1	F	Uplink distribution deployment option	14.1.0
2016-12	SP-74	SP-160814	0010	1	F	Clarification on location mapping at V2X Application Server	14.1.0
2016-12	SP-74	SP-160814	0012	1	F	Definition of the USD for Uu based V2X communication and V2X Application Server discovery	14.1.0
2016-12	SP-74	SP-160814	0013	1	F	Clarification of multiple TMGIs uses in overlapping areas	14.1.0
2016-12	SP-74	SP-160814	0015	1	F	V2X communication over PC5 is used for UEs in limited service state	14.1.0
2016-12	SP-74	SP-160814	0016	2	F	Resolve EN related to source IP change for IP based V2X communication over PC5	14.1.0
2016-12	SP-74	SP-160814	0017	1	B	Charging support for V2X Communication	14.1.0
2016-12	SP-74	SP-160814	0018	1	B	Parameter pre-configuration and usage of the UE for V2X communication	14.1.0
2016-12	SP-74	SP-160814	0020	1	F	Procedure for V2 reference point	14.1.0
2017-03	SP-75	SP-170045	0023	1	F	Clarify relation of PPPP, PDB & priority	14.2.0
2017-03	SP-75	SP-170045	0024	1	C	Support for xMB for V2X application	14.2.0
2017-03	SP-75	SP-170045	0025	1	F	Clarify IP routing of V2X service over LTE Uu with PSID, ITS-AID	14.2.0
2017-03	SP-75	SP-170045	0026	1	C	Clarification for V2X communication over PC5 in limited service state	14.2.0
2017-03	SP-75	SP-170045	0027	2	C	Support of V2X communication over PC5 during IMS eCall	14.2.0
2017-03	SP-75	SP-170045	0028	1	F	Clarification for V2X charging	14.2.0
2017-03	SP-75	SP-170045	0029	1	B	Clarification for V2X Security	14.2.0
2017-06	SP-76	SP-170364	0030	1	F	Clarification for definition of "not served by E-UTRAN"	14.3.0
2017-06	SP-76	SP-170364	0031	2	F	Clarification on privacy requirements for V2X communication	14.3.0
2017-06	SP-76	SP-170364	0032	2	F	Mapping between service types and V2X frequencies	14.3.0
2017-09	SP-77	SP-170722	0034	1	F	Correction on radio resources	14.4.0
2017-12	SP-78	SP-170917	0036	1	F	Clarification to mapping between service types and V2X frequencies	14.5.0
2018-03	SP-79	SP-180088	0039	1	F	Clarification on PC5 parameters from V2X Application Server	14.6.0
2018-03	SP-79	SP-180114	0037	1	C	Support of Reliable transmission over PC5 using extended PPPP	15.0.0
2018-06	SP-80	SP-180472	0042	1	A	Optional Duplicate Address Detection for V2X Communication over PC5	15.1.0
2018-06	SP-80	SP-180473	0040	1	F	Reliability for eV2X for LTE clarification	15.1.0
2018-06	SP-80	SP-180473	0044	2	F	Support of PC5 transmission mechanism selection using Tx Profile	15.1.0

History

Document history		
V15.1.0	July 2018	Publication