

ETSI TS 118 132 V4.0.1 (2023-08)



MAF and MEF Interface Specification (oneM2M TS-0032 version 4.0.1 Release 4)



Reference

RTS/oneM2M-000032V4

Keywords

IoT, M2M

ETSI

650 Route des Lucioles
F-06921 Sophia Antipolis Cedex - FRANCE

Tel.: +33 4 92 94 42 00 Fax: +33 4 93 65 47 16

Siret N° 348 623 562 00017 - APE 7112B
Association à but non lucratif enregistrée à la
Sous-Préfecture de Grasse (06) N° w061004871

Important notice

The present document can be downloaded from:

<https://www.etsi.org/standards-search>

The present document may be made available in electronic versions and/or in print. The content of any electronic and/or print versions of the present document shall not be modified without the prior written authorization of ETSI. In case of any existing or perceived difference in contents between such versions and/or in print, the prevailing version of an ETSI deliverable is the one made publicly available in PDF format at www.etsi.org/deliver.

Users of the present document should be aware that the document may be subject to revision or change of status.

Information on the current status of this and other ETSI documents is available at

<https://portal.etsi.org/TB/ETSIDeliverableStatus.aspx>

If you find errors in the present document, please send your comment to one of the following services:

<https://portal.etsi.org/People/CommitteeSupportStaff.aspx>

If you find a security vulnerability in the present document, please report it through our
Coordinated Vulnerability Disclosure Program:

<https://www.etsi.org/standards/coordinated-vulnerability-disclosure>

Notice of disclaimer & limitation of liability

The information provided in the present deliverable is directed solely to professionals who have the appropriate degree of experience to understand and interpret its content in accordance with generally accepted engineering or other professional standard and applicable regulations.

No recommendation as to products and services or vendors is made or should be implied.

No representation or warranty is made that this deliverable is technically accurate or sufficient or conforms to any law and/or governmental rule and/or regulation and further, no representation or warranty is made of merchantability or fitness for any particular purpose or against infringement of intellectual property rights.

In no event shall ETSI be held liable for loss of profits or any other incidental or consequential damages.

Any software contained in this deliverable is provided "AS IS" with no warranties, express or implied, including but not limited to, the warranties of merchantability, fitness for a particular purpose and non-infringement of intellectual property rights and ETSI shall not be held liable in any event for any damages whatsoever (including, without limitation, damages for loss of profits, business interruption, loss of information, or any other pecuniary loss) arising out of or related to the use of or inability to use the software.

Copyright Notification

No part may be reproduced or utilized in any form or by any means, electronic or mechanical, including photocopying and microfilm except as authorized by written permission of ETSI.

The content of the PDF version shall not be modified without the written authorization of ETSI.

The copyright and the foregoing restriction extend to reproduction in all media.

© ETSI 2023.
All rights reserved.

ETSI

Contents

| | |
|--|----|
| Intellectual Property Rights | 5 |
| Foreword..... | 5 |
| 1 Scope | 6 |
| 2 References | 6 |
| 2.1 Normative references | 6 |
| 2.2 Informative references..... | 6 |
| 3 Definition of terms, symbols and abbreviations..... | 7 |
| 3.1 Terms..... | 7 |
| 3.2 Symbols..... | 7 |
| 3.3 Abbreviations | 7 |
| 4 Conventions..... | 8 |
| 5 General Description..... | 8 |
| 5.1 MAF Interface | 8 |
| 5.1.1 Introduction..... | 8 |
| 5.1.2 MAF Interface Overview | 9 |
| 5.2 MEF Interface | 11 |
| 5.2.1 Introduction..... | 11 |
| 5.2.2 MEF Interface Overview | 13 |
| 6 Processing and Representation of Primitives | 14 |
| 6.1 Common aspects of the MAF and MEF interface | 14 |
| 6.2 MAF Interface | 14 |
| 6.3 MEF Interface | 15 |
| 7 Resource types definitions..... | 15 |
| 7.1 Namespaces used for resource and data types | 15 |
| 7.2 Resource Type <MAFBase> | 15 |
| 7.3 Resource Type <MEFBase> | 16 |
| 7.4 Resource Type <mafClientReg>..... | 16 |
| 7.5 Resource Type <mefClientReg> | 17 |
| 7.6 Resource Type <symmKeyReg>..... | 18 |
| 7.7 Resource Type <mefClientCmd>..... | 19 |
| 8 Resource-type specific procedures and definitions | 19 |
| 8.1 Resource Type <MAFBase> | 19 |
| 8.1.1 Introduction..... | 19 |
| 8.1.2 <MAFBase> resource specific procedures on CRUD operations | 20 |
| 8.1.2.1 Create | 20 |
| 8.1.2.2 Retrieve | 20 |
| 8.1.2.3 Update | 20 |
| 8.1.2.4 Delete | 20 |
| 8.2 Resource Type <MEFBase> | 21 |
| 8.2.1 Introduction..... | 21 |
| 8.2.2 <MEFBase> resource specific procedures on CRUD operations | 21 |
| 8.2.2.1 Create | 21 |
| 8.2.2.2 Retrieve | 21 |
| 8.2.2.3 Update | 22 |
| 8.2.2.4 Delete | 22 |
| 8.3 Resource Type <mafClientReg>..... | 22 |
| 8.3.1 Introduction..... | 22 |
| 8.3.2 <mafClientReg> resource specific procedures on CRUD operations | 23 |
| 8.3.2.1 Create | 23 |
| 8.3.2.2 Retrieve | 24 |
| 8.3.2.3 Update | 24 |
| 8.3.2.4 Delete | 25 |

| | | |
|---------|---|----|
| 8.4 | Resource Type < <i>mefClientReg</i> > | 25 |
| 8.4.1 | Introduction..... | 25 |
| 8.4.2 | < <i>mefClientReg</i> > resource specific procedures on CRUD operations..... | 26 |
| 8.4.2.1 | Create | 26 |
| 8.4.2.2 | Retrieve | 27 |
| 8.4.2.3 | Update | 28 |
| 8.4.2.4 | Delete | 28 |
| 8.5 | Resource Type < <i>symmKeyReg</i> > | 29 |
| 8.5.1 | Introduction..... | 29 |
| 8.5.2 | < <i>symmKeyReg</i> > resource specific procedures on CRUD operations..... | 29 |
| 8.5.2.1 | Create | 29 |
| 8.5.2.2 | Retrieve | 31 |
| 8.5.2.3 | Update | 31 |
| 8.5.2.4 | Delete | 31 |
| 8.6 | Resource Type < <i>mefClientCmd</i> >..... | 32 |
| 8.6.1 | Introduction..... | 32 |
| 8.6.2 | < <i>mefClientCmd</i> > resource specific procedures on CRUD operations | 33 |
| 8.6.2.1 | Create | 33 |
| 8.6.2.2 | Retrieve | 33 |
| 8.6.2.3 | Update | 34 |
| 8.6.2.4 | Delete | 34 |
| 9 | Short Names | 35 |
| 9.1 | Introduction | 35 |
| 9.2 | Security-specific oneM2M Resource attributes..... | 35 |
| 9.3 | Security-specific oneM2M Resource types | 35 |
| 9.4 | Security-specific oneM2M Complex data type members..... | 36 |
| | History | 38 |

Intellectual Property Rights

Essential patents

IPRs essential or potentially essential to normative deliverables may have been declared to ETSI. The declarations pertaining to these essential IPRs, if any, are publicly available for **ETSI members and non-members**, and can be found in ETSI SR 000 314: "*Intellectual Property Rights (IPRs); Essential, or potentially Essential, IPRs notified to ETSI in respect of ETSI standards*", which is available from the ETSI Secretariat. Latest updates are available on the ETSI Web server (<https://ipr.etsi.org/>).

Pursuant to the ETSI Directives including the ETSI IPR Policy, no investigation regarding the essentiality of IPRs, including IPR searches, has been carried out by ETSI. No guarantee can be given as to the existence of other IPRs not referenced in ETSI SR 000 314 (or the updates on the ETSI Web server) which are, or may be, or may become, essential to the present document.

Trademarks

The present document may include trademarks and/or tradenames which are asserted and/or registered by their owners. ETSI claims no ownership of these except for any which are indicated as being the property of ETSI, and conveys no right to use or reproduce any trademark and/or tradename. Mention of those trademarks in the present document does not constitute an endorsement by ETSI of products, services or organizations associated with those trademarks.

DECT™, **PLUGTESTS™**, **UMTS™** and the ETSI logo are trademarks of ETSI registered for the benefit of its Members. **3GPP™** and **LTE™** are trademarks of ETSI registered for the benefit of its Members and of the 3GPP Organizational Partners. **oneM2M™** logo is a trademark of ETSI registered for the benefit of its Members and of the oneM2M Partners. **GSM®** and the GSM logo are trademarks registered and owned by the GSM Association.

Foreword

This Technical Specification (TS) has been produced by ETSI Partnership Project oneM2M (oneM2M).

1 Scope

The present document specifies communication between the M2M Authentication Function (MAF) and MAF clients on the reference point Mmaf and between the M2M Enrolment Function (MEF) and MEF clients on the reference point Mmef.

2 References

2.1 Normative references

References are either specific (identified by date of publication and/or edition number or version number) or non-specific. For specific references, only the cited version applies. For non-specific references, the latest version of the referenced document (including any amendments) applies.

Referenced documents which are not found to be publicly available in the expected location might be found at <https://docbox.etsi.org/Reference/>.

NOTE: While any hyperlinks included in this clause were valid at the time of publication, ETSI cannot guarantee their long term validity.

The following referenced documents are necessary for the application of the present document.

- [1] [ETSI TS 118 101](#): "oneM2M; Functional Architecture (oneM2M TS-0001)".
- [2] [ETSI TS 118 103](#): "oneM2M; Security solutions (oneM2M TS-0003)".
- [3] [ETSI TS 118 104](#): "oneM2M; Service Layer Core Protocol Specification (oneM2M TS-0004)".
- [4] [ETSI TS 118 108](#): "oneM2M; CoAP Protocol Binding (oneM2M TS-0008)".
- [5] [ETSI TS 118 109](#): "oneM2M; HTTP Protocol Binding (oneM2M TS-0009)".
- [6] [ETSI TS 118 110](#): "oneM2M; MQTT Protocol Binding (oneM2M TS-0010)".
- [7] [ETSI TS 118 111](#): "oneM2M; Common Terminology (oneM2M TS-0011)".
- [8] [ETSI TS 118 120](#): "oneM2M; WebSocket Protocol Binding (oneM2M TS-0020)".
- [9] [ETSI TS 118 122](#): "oneM2M; Field Device Configuration (oneM2M TS-0022)".

2.2 Informative references

References are either specific (identified by date of publication and/or edition number or version number) or non-specific. For specific references, only the cited version applies. For non-specific references, the latest version of the referenced document (including any amendments) applies.

NOTE: While any hyperlinks included in this clause were valid at the time of publication, ETSI cannot guarantee their long term validity.

The following referenced documents are not necessary for the application of the present document but they assist the user with regard to a particular subject area.

- [i.1] [oneM2M Drafting Rules](#).

3 Definition of terms, symbols and abbreviations

3.1 Terms

For the purposes of the present document, the terms given in ETSI TS 118 111 [7], ETSI TS 118 103 [2] and the following apply:

MAF Client: functionality for performing MAF procedures on behalf of an associated CSE or AE, or on behalf of CSE or AE(s) present on an associated Node

MAF interface: communication interface between a MAF and a MAF Client identified by reference point Mmaf

MEF Client: functionality for performing MEF procedures on behalf of an associated CSE or AE, or on behalf of CSE or AE(s) present on an associated Node, or an associated MAF

MEF interface: communication interface between a MEF and a MEF Client identified by reference point Mmef

3.2 Symbols

Void.

3.3 Abbreviations

For the purposes of the present document, the abbreviations given in ETSI TS 118 111 [7], ETSI TS 118 103 [2] and the following abbreviations apply:

| | |
|--------|--|
| ADN | Application Dedicated Node |
| AE | Application Entity |
| AE-ID | Application Entity Identifier |
| API | Application Programming Interface |
| ASN | Application Service Node |
| BBF | Broadband Forum |
| CDT | Common Data Types |
| CRUD | Create, Retrieve, Update, Delete (operation) |
| CSE | Common Services Entity |
| CSE-ID | Common Services Entity Identifier |
| DM | Device Management |
| DTLS | Datagram Transport Layer Security |
| FQDN | Fully Qualified Domain Name |
| HTTP | Hypertext Transfer Protocol |
| IN | Infrastructure Node |
| MAF | M2M Authentication Function |
| MEF | M2M Enrolment Function |
| MN | Middle Node |
| MQTT | Message Queue Telemetry Transport |
| MTE | M2M Trust Enabler |
| NP | Not Present |
| RSPF | Remote Security Provisioning Framework |
| RO | Read-Only |
| RW | Read-Write |
| SEC | Security |
| SP | Service Provider |
| SP-ID | Service Provider Identifier |
| SUID | Security Usage Identifier |
| TLS | Transport Layer Security |
| WO | Write-Only |
| XML | Extensible Markup Language |

4 Conventions

The key words "Shall", "Shall not", "May", "Need not", "Should", "Should not" in the present document are to be interpreted as described in the oneM2M Drafting Rules [i.1].

5 General Description

5.1 MAF Interface

5.1.1 Introduction

The MAF Interface is a simple variant of the Mcc/Mca reference points specifying the interaction of MAF Clients with a M2M Authentication Function (MAF), acting on behalf of an *administrating stakeholder* such as an M2M SP or third party M2M Trust Enabler (MTE). The present document does not specify the operation and management of the MAF required to support these procedures.

A MAF Client interacts with the MAF on behalf of a Node (ADN, ASN, IN or MN), or a CSE or an AE.

Figure 5.1.1-1 defines the reference point Mmaf between MAF clients and a MAF.

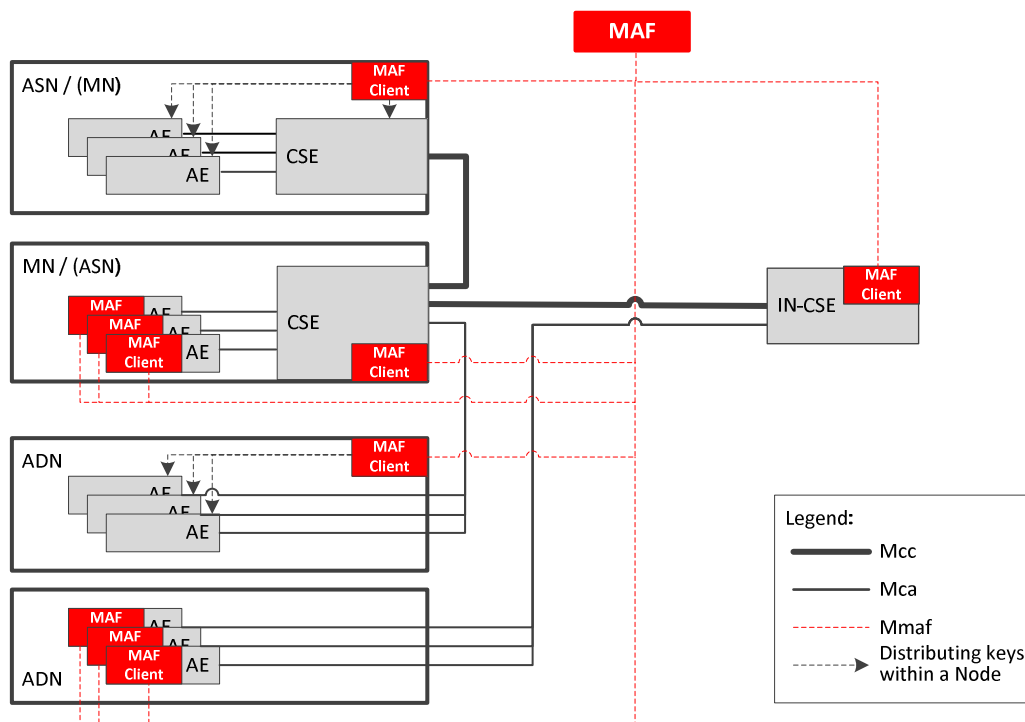

Figure 5.1.1-1: Reference Architecture for MAF

The administrating stakeholder authorizes the MAF's services to MAF clients, and oversees authorizing the distribution of symmetric keys. A MAF may provide its services on behalf of multiple administrating stakeholders. A MAF Client may be associated with multiple administrating stakeholders, each administrating the use of the MAF within a different scope.

NOTE 1: The administrating stakeholder could be an M2M SP administrating the registration and distribution of credentials used for SAEFs and ESPrim within the M2M SP's Domain.

NOTE 2: The administrating stakeholder could be an MTE administrating the registration and distribution of credentials for ESPrim and ESData to MAF Clients belonging to a particular Application Service Provider, where the MAF Clients could be distributed over multiple M2M SP domains.

The present document has no impact on the specifications in ETSI TS 118 101 [1] and ETSI TS 118 104 [3]. However, the MAF Interface uses much of the specification in ETSI TS 118 104 [3] and in particular allows use of the HTTP binding in ETSI TS 118 108 [4], the CoAP binding in ETSI TS 118 109 [5] and the WebSocket binding in oneM2M ETSI TS 118 120 [8].

NOTE 3: The MQTT binding in oneM2M ETSI TS 118 110 [6] is not suitable for the MAF Interface, because the MAF Interface assumes a TLS or DTLS connection from the MAF Client to the MAF – which is not possible using the MQTT binding.

The MAF Interface incorporates the following concepts from the Mcc/Mca reference points:

- The concept of operations acting on resources.
- The resource addressing from Mcc/Mca is used.
- The universal attributes and some common attributes of resources.

The MAF Interface differs from Mcc/Mca in the following ways:

- The MAF Client can only communicate directly with the MAF – there are no transited CSEs. Only Blocking Mode communication method is supported.
- None of the resource types applicable on Mcc/Mca are used:
 - Access control decisions use simple access control list for Retrieve access, and *<accessControlPolicy>* resources are not used for resources hosted by the MAF. A consequence of this is that the *accessControlPolicyIDs* attributes are not needed in the resources hosted by the MAF.
 - The *<subscription>* resource and NOTIFY operations are not supported.
 - There is no AE registration or CSE registration, but a similar process where a MAF Client creates a *<mafClientReg>* (MAF Client registration record) resource on the MAF.
 - There are no announced resources.

The hierarchy of resources hosted by a MAF shall be as follows:

- *<MAFBase>* resource type is the structural root for all the resources that are residing on a MAF. This resource is implicitly created by the MAF and uses the fixed resource name "maf" and contains following child resources:
 - *<mafClientReg>* resource. It confirms the MAF Client's registration to an administrating stakeholder, and can contain configuration information to be returned to the MAF Client.
 - *<symmKeyReg>* resources. It is created by the MAF Client, and contains symmetric keys for retrieval by another MAF Client.

5.1.2 MAF Interface Overview

This MAF Interface overview is based on the specification in clause 6 of ETSI TS 118 104 [3].

Identifiers such as M2M-SP-ID, AE-ID and CSE-ID as defined in 6.2.3 of [3] also apply to the MAF Interface. M2M Trust Enablers (MTEs) are identified using an M2M-SP-ID.

Resources are addressed as specified in clause 6.2.4 in [3].

Common data types applicable to the MAF Interface are inherited from clause 6.3 of [3]. However, for any parameters or elements which have assigned the enumerated data type *m2m:resourceType*, the applicable enumeration values are interpreted as specified in Table 5.1.2-4. This applies to the **Resource Type** primitive parameter, the common *resourceType* attribute, and the *@type* attribute of *m2m:childResourceRef*.

Tables 5.1.2-1 and 5.1.2-2 list the request and response primitive parameters inherited from clauses 6.4.1 and 6.4.2 in ETSI TS 118 104 [3], respectively; the data types of these parameters are unchanged. The **From** parameter shall include the MAF client ID which can be a Node-ID, AE-ID or CSE-ID, depending on whether the client acts on behalf of a node, AE or CSE. Note that this is in contrast to primitives on the Mca and Mcc interface, where the **From** primitive parameter cannot include a Node-ID.

NOTE: All other optional request and response primitive parameters defined in clause 6.4.1 of oneM2M ETSI TS 118 104 [3] are not used on the MAF Interface.

Table 5.1.2-1: MAF Interface request primitive parameters

| Parameter | Multiplicity | Notes |
|--------------------|--------------|---|
| Operation | 1 | |
| To | 1 | |
| From | 0..1 | If not present, the MAF internally assigns From to be the identity of the Node, CSE or AE associated with the credential used for the MAF Handshake procedure. |
| Request Identifier | 1 | |
| Resource Type | 0..1 | values of m2m:resourceType interpreted as in Table 5.1.2-4 |
| Content | 0..1 | |
| Result Content | 0..1 | |

Table 5.1.2-2: MAF Interface response primitive parameters

| Parameter | Multiplicity | Notes |
|----------------------|--------------|-------|
| Response Status Code | 1 | |
| Request Identifier | 1 | |
| Content | 0..1 | |

Data types associated with resources applicable to the MAF Interface are defined in clause 7.

Table 5.1.2-3 lists the response status codes from clause 6.6 of ETSI TS 118 104 [3] which are supported by the MAF Interface.

Table 5.1.2-3: Response status codes supported by the MAF Interface

| Response status codes | Interpretation |
|-----------------------|-----------------------|
| 2000 | OK |
| 2001 | CREATED |
| 2002 | DELETED |
| 2004 | UPDATED |
| 4000 | BAD_REQUEST |
| 4004 | NOT_FOUND |
| 4005 | OPERATION_NOT_ALLOWED |
| 4103 | ACCESS_DENIED |
| 5000 | INTERNAL_SERVER_ERROR |

Table 5.1.2-4: Interpretation of enumeration values of m2m:resourceType

| Value | Interpretation | Note |
|-------|----------------|------|
| 1 | MAFBase | |
| 2 | MEFBase | |
| 3 | mafClientReg | |
| 4 | mefClientReg | |
| 5 | symmKeyReg | |
| 6 | mefClientCmd | |

The MIME media types defined on clause 6.7 of ETSI TS 118 104 [3] shall be supported on the MAF interface. The notification related Media types vnd.onem2m-ntfy+json, vnd.onem2m-ntfy+cbor, vnd.onem2m-preq+xml do not apply to the MAF interface.

Virtual resources (clause 6.8 of ETSI TS 118 104 [3]) are not supported by the MAF Interface.

5.2 MEF Interface

5.2.1 Introduction

The M2M Enrolment Function (MEF) is an essential part of the oneM2M Remote Security Provisioning architecture.

Clause 6.1.2.1 of ETSI TS 118 103 [2] defines the following three variants of Remote Security Provisioning Frameworks (RSPF):

- Pre-Provisioned Symmetric Key RSPF
- Certificate-Based RSPF
- GBA-based RSPF

The MEF interface defined in the present specification applies to Pre-Provisioned Symmetric Key RSPF and Certificate-Based RSPF only. For interfaces and procedures applicable to GBA-based RSPF, see clause 8.3.2.3 of ETSI TS 118 103 [2].

When using Pre-Provisioned Symmetric Enrollee Key RSPF or Certificate-Based RSPF, the MEF serves a number of different use cases which are summarized as follows:

- 1) The MEF provisions an Enrollee to perform MAF Security Framework procedures with a MAF as defined in clause 8.8.2 of ETSI TS 118 103 [2].
- 2) The MEF provisions an Entity A and an Entity B to perform Security Association Establishment as defined in clauses 8.2.2.1 and 8.2.2.2 of ETSI TS 118 103 [2].
- 3) The MEF provisions an originator and a receiver of a primitive with credentials to enable End-to-End Security of Primitives (ESPRIM) with security credentials as specified in clause 8.4 of ETSI TS 118 103 [2].
- 4) The MEF provisions the source and target endpoints of End-to-End Security of Data (ESDATA) as specified in clause 8.5 of ETSI TS 118 103 [2].

The present document defines messages and procedures for the above listed MEF use cases.

NOTE 1: A MEF may also be implemented as a Device Management server using device management protocols such as OMA DM, OMA LwM2M and BBF TR-069. Such procedures are defined in ETSI TS 118 103 [2] and ETSI TS 118 122 [9].

Like the Mmaf Interface, the Mmef Interface is a simple variant of the Mcc/Mca reference points specifying the interaction of MEF Clients with a M2M Enrolment Function (MEF), managing symmetric keys on behalf of an *administrating stakeholder* such as an M2M SP or third party M2M Trust Enabler (MTE). The present document does not specify the operation and management of the MEF required to support these procedures.

A MEF Client interacts with the MEF on behalf of a Node (ADN, ASN, IN or MN), or a CSE or an AE for use cases 1) and 2) in the above list. Figure 5.2.1-1 defines the reference point Mmef between MEF clients and a MEF, and between MEF and MAF.

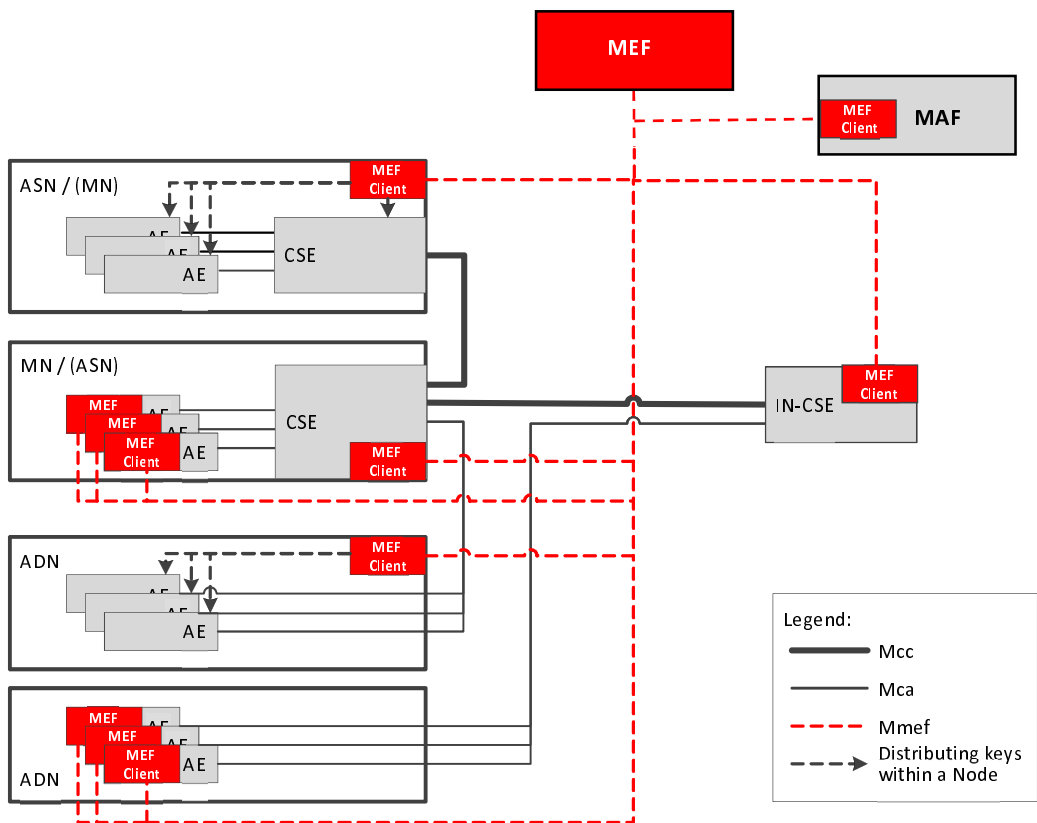

Figure 5.2.1-1: Reference Architecture for MEF

The administrating stakeholder authorizes the MEF's services to MEF clients. A MEF may provide its services on behalf of multiple administrating stakeholders. A MEF Client may be associated with multiple administrating stakeholders, each administrating the use of the MEF within a different scope.

NOTE 2: The administrating stakeholder could be an M2M SP administrating the registration and distribution of credentials used for SAEFs and ESPrim within the M2M SP's Domain.

NOTE 3: The administrating stakeholder could be an MTE administrating the registration and distribution of credentials for ESPrim and ESData to MEF Clients belonging to a particular Application Service Provider, where the MEF Clients could be distributed over multiple M2M SP domains.

The present document has no impact on the specifications in ETSI TS 118 101 [1] and ETSI TS 118 104 [3]. However, the MEF Interface uses much of the specification in ETSI TS 118 104 [3] and in particular allows use of the HTTP binding in ETSI TS 118 108 [4], the CoAP binding in ETSI TS 118 109 [5] and the WebSocket binding in ETSI TS 118 120 [8].

NOTE 4: The MQTT binding in ETSI TS 118 110 [6] is not suitable for the MEF Interface, because the MEF Interface assumes a TLS or DTLS connection from the MEF Client to the MEF – which is not possible using the MQTT binding.

The MEF Interface incorporates the following concepts from the Mcc/Mca reference points:

- 1) The concept of operations acting on resources.
- 2) The resource addressing from Mcc/Mca is used.
- 3) The universal attributes and some common attributes of resources.

The MEF Interface differs from Mcc/Mca in the following ways:

- 4) The MEF Client can only communicate directly with the MEF - there are no transited CSEs. Only Blocking Mode communication method is supported.

- 5) None of the resource types applicable on Mcc/Mca are used:
 - Access control decisions use simple access control list for Retrieve access, and <accessControlPolicy> resources are not used for resources hosted by the MEF. A consequence of this is that the accessControlPolicyIDs attributes are not needed in the resources hosted by the MEF.
 - The <subscription> resource and NOTIFY operations are not supported.
 - There is no AE registration or CSE registration, but a similar process where a MEF Client creates a <mefClientReg> (MEF Client registration record) resource on the MEF.
 - There are no announced resources.

The hierarchy of resources hosted by a MEF shall be as follows:

- 6) <MEFBase> resource type is the structural root for all the resources that are residing on a MEF. This resource is implicitly created by the MEF and uses the fixed resource name "mef" and contains following child resources:
 - <mefClientReg> resource. It confirms the MEF Client's registration to an administrating stakeholder, and can contain configuration information to be returned to the MEF Client.
 - <symmKeyReg> resources. It is created by the MEF Client, and contains symmetric keys for retrieval by another MEF Client.

5.2.2 MEF Interface Overview

This MEF Interface overview is based on the specification in clause 6 of ETSI TS 118 104 [3].

Identifiers such as M2M-SP-ID, AE-ID and CSE-ID as defined in 6.2.3 of ETSI TS 118 104 [3] also apply to the MEF Interface. M2M Trust Enablers (MTEs) are identified using an M2M-SP-ID.

Resources are addressed as specified in clause 6.2.4 in [3].

Common data types applicable to the MEF Interface are inherited from clause 6.3 of [3]. However, for any parameters or elements which have assigned the enumerated data type m2m:resourceType, the applicable enumeration values are interpreted as specified in Table 5.1.2-4. This applies to the **Resource Type** primitive parameter, the common *resourceType* attribute, and the @type attribute of m2m:childResourceRef.

Tables 5.2.2-1 and 5.2.2-2 list the request and response primitive parameters inherited from clauses 6.4.1 and 6.4.2 in ETSI TS 118 104 [3], respectively; the data types of these parameters are unchanged. The **From** parameter shall include the MEF client ID which can be a Node-ID, AE-ID or CSE-ID, depending on whether the client acts on behalf of a node, AE or CSE. Note that this is in contrast to primitives on the Mca and Mcc interface, where the **From** primitive parameter cannot include a Node-ID.

NOTE: All other optional request and response primitive parameters defined in clause 6.4.1 of [3] are not used on the MEF Interface.

Table 5.2.2-1: MEF Interface request primitive parameters

| Parameter | Multiplicity | Notes |
|--------------------|--------------|---|
| Operation | 1 | |
| To | 1 | |
| From | 0..1 | If not present, the MEF internally assigns From to be the identity of the Node, CSE or AE associated with the credential used for the MEF Handshake procedure. |
| Request Identifier | 1 | |
| Resource Type | 0..1 | values of m2m:resourceType interpreted as in Table 5.1.2-4. |
| Content | 0..1 | |
| Result Content | 0..1 | |

Table 5.2.2-2: MEF Interface response primitive parameters

| Parameter | Multiplicity | Notes |
|----------------------|--------------|-------|
| Response Status Code | 1 | |
| Request Identifier | 1 | |
| Content | 0..1 | |

Data types associated with resources applicable to the MEF Interface are defined in clause 7.

The response status codes listed in table 5.1.2-3 also apply to the MEF Interface.

The MIME media types defined on clause 6.7 of ETSI TS 118 104 [3] shall be supported on the MEF interface. The notification related Media types vnd.onem2m-ntfy+json, vnd.onem2m-ntfy+cbor, vnd.onem2m-preq+xml do not apply to the MEF interface.

Virtual resources (clause 6.8 of [3]) are not supported by the MEF Interface.

6 Processing and Representation of Primitives

6.1 Common aspects of the MAF and MEF interface

This clause corresponds to the specification in clauses 7 and 8 of ETSI TS 118 104 [3].

Both, MAF and MEF Interface request primitive formats conform to clause 7.2.1.1 of ETSI TS 118 104 [3], constrained to the CRUD operations, with request parameters listed in table 5.1.2-1 and table 5.2.2-1, respectively.

Both, MAF and MEF Interface response primitive formats conform to clause 7.2.1.2 of ETSI TS 118 104 [3], constrained to the CRUD operations, with response parameters listed in table 5.1.2-2 and table 5.2.2-2, respectively.

6.2 MAF Interface

The MAF Interface generic resource request procedure for originators and receivers conforms to clauses 7.2.2.1 and 7.2.2.2 of ETSI TS 118 104 [3], with the following clarification:

- The MAF Client acts as the originator, and the MAF acts as the receiver and resource hosting entity.
- The MAF Handshake procedure (clause 8.8.2.2 of ETSI TS 118 103 [2]) is used for mutual authentication of the MAF Client and MAF.
- The operation shall be one of the CRUD operations.
- The request and response parameters shall conform to table 5.1.2-1 and table 5.1.2-2.
- "Blocking Mode" communication method shall be used.
- The step Recv-6.3: "Check authorization of the Originator" is replaced by the authorization processes described in the MAF Interface resource-type specific procedures in clause 8.

The originator actions, receiver actions and Hosting CSE actions conform to clause 7.3 of ETSI TS 118 104 [3], with clause 7.3.3.15 of [3] replaced by the authorization processes described in the MAF Interface resource-type specific procedures in clause 8.

The management common operations in clause 7.3.4 of [3] do not apply to the MAF Interface.

The resource-type-specification conventions apply to the specification in clause 8, but the remainder of clause 7.4 of [3] does not apply to the MAF Interface.

Clause 7.5.1 of [3] (regarding Notification) does not apply to the MAF Interface. Elements contained in the Content primitive parameter conform to clause 7.5.2 of [3].

The representation of MAF Interface primitives in data transfer conforms to clause 8. Clause 9 contains additional short names specific to both, the MAF and MEF Interfaces.

6.3 MEF Interface

The MEF Interface generic resource request procedure for originators and receivers conforms to clauses 7.2.2.1 and 7.2.2.2 of ETSI TS 118 104 [3] with the following clarification:

- The MEF Client acts as the originator, and the MEF acts as the receiver and resource hosting entity.
- The MEF Handshake procedure (clause 8.3.5.2.2 of ETSI TS 118 103 [2]) is used for mutual authentication of the MEF Client and MEF.
- The operation shall be one of the CRUD operations.
- The request and response parameters shall conform to table 5.2.2-1 and table 5.2.2-2.
- "Blocking Mode" communication method shall be used.
- The step Recv-6.3: "Check authorization of the Originator" is replaced by the authorization processes described in the MEF Interface resource-type specific procedures in clause 8.

The originator actions, receiver actions and Hosting CSE actions conform to clause 7.3 of ETSI TS 118 104 [3], with clause 7.3.3.15 of [3] replaced by the authorization processes described in the MEF Interface resource-type specific procedures in clause 8.

The management common operations in clause 7.3.4 of [3] do not apply to the MEF Interface.

The resource-type-specification conventions apply to the specification in clause 8, but the remainder of clause 7.4 of [3] does not apply to the MEF Interface.

Clause 7.5.1 of [3] (regarding Notification) does not apply to the MEF Interface. Elements contained in the Content primitive parameter conform to clause 7.5.2 of [3].

The representation of MEF Interface primitives in data transfer conforms to clause 8. Clause 9 contains additional short names specific to the both, the MAF and MEF Interfaces.

7 Resource types definitions

7.1 Namespaces used for resource and data types

Representations of resources applicable to the MAF and MEF Interfaces employ the namespace identifier "sec:" for global XML elements associated with a resource type. Data types of the attributes and complex-type elements of these resource types may use any of the name space identifiers listed in table 7.1-1.

Any data types of XML elements defined for use in present document shall be one of name spaces in table 7.1-1.

Table 7.1-1: Namespaces applicable to resource types defined in the present document

| Name space | prefix | Name space definition | Types defined in |
|----------------------|--------|---|--|
| oneM2M Security | sec: | http://www.onem2m.org/xml/securityProtocols | the present document and ETSI TS 118 103 [2] |
| oneM2M protocol CDT | m2m: | http://www.onem2m.org/xml/protocol | ETSI TS 118 104 [3] |
| Device Configuration | dcfg: | http://www.onem2m.org/xml/deviceConfig | ETSI TS 118 122 [9] |

7.2 Resource Type <MAFBase>

The <MAFBase> resource shall represent a MAF.

The *<MAFBase>* resource shall contain the child resources specified in table 7.2-1.

Table 7.2-1: Child resources of *<MAFBase>* resource

| Child Resources of <i><MAFBase></i> | Child Resource Type | Multiplicity | Description |
|---|-----------------------------|--------------|----------------|
| [variable] | <i><mafClientReg></i> | 0..n | See clause 7.3 |
| [variable] | <i><symmKeyReg></i> | 0..n | See clause 7.4 |

The *<MAFBase>* resource shall contain the attributes specified in table 7.2-2.

Table 7.2-2: Attributes of *<MAFBase>* resource

| Attributes of <i><MAFBase></i> | Multiplicity | RW/RO/WO | Description |
|--------------------------------------|--------------|----------|---|
| <i>resourceType</i> | 1 | RO | See clause 9.6.1.3 of ETSI TS 118 101 [1]. |
| <i>resourceID</i> | 1 | RO | See clause 9.6.1.3 of ETSI TS 118 101 [1]. |
| <i>resourceName</i> | 1 | RO | See clause 9.6.1.3 of ETSI TS 118 101 [1]. Shall be fixed to "maf". |
| <i>creationTime</i> | 1 | RO | See clause 9.6.1.3 of ETSI TS 118 101 [1]. |
| <i>labels</i> | 1 | RO | See clause 9.6.1.3 of ETSI TS 118 101 [1]. |

7.3 Resource Type *<MEFBase>*

The *<MEFBase>* resource shall represent a MEF.

The *<MEFBase>* resource shall contain the child resources specified in table 7.3-1.

Table 7.3-1: Child resources of *<MEFBase>* resource

| Child Resources of <i><MEFBase></i> | Child Resource Type | Multiplicity | Description |
|---|-----------------------------|--------------|----------------|
| [variable] | <i><mefClientReg></i> | 0..n | See clause 7.4 |
| [variable] | <i><symmKeyReg></i> | 0..n | See clause 7.6 |

The *<MEFBase>* resource shall contain the attributes specified in table 7.3-2.

Table 7.3-2: Attributes of *<MEFBase>* resource

| Attributes of <i><MEFBase></i> | Multiplicity | RW/RO/WO | Description |
|--------------------------------------|--------------|----------|---|
| <i>resourceType</i> | 1 | RO | See clause 9.6.1.3 of ETSI TS 118 101 [1]. |
| <i>resourceID</i> | 1 | RO | See clause 9.6.1.3 of ETSI TS 118 101 [1]. |
| <i>resourceName</i> | 1 | RO | See clause 9.6.1.3 of ETSI TS 118 101 [1]. Shall be fixed to "mef". |
| <i>creationTime</i> | 1 | RO | See clause 9.6.1.3 of ETSI TS 118 101 [1]. |
| <i>labels</i> | 1 | RO | See clause 9.6.1.3 of ETSI TS 118 101 [1]. |

7.4 Resource Type *<mafClientReg>*

The *<mafClientReg>* resource shall represent a MAF Client enrolled with an M2M SP or M2M Trust Enabler (MTE).

NOTE: A single MAF Client can be enrolled with at most one M2M SP and any number of MTEs (typically enabling end-to-end security to MAF Clients outside the MAF Client's M2M SP's domain). Consequently, a single MAF Client can be associated with multiple *<mafClientReg>* resources on multiple MAFs. It is also possible that a single MAF Client can be associated with multiple *<mafClientReg>* resources on a single MAF acting on behalf of multiple administrating stakeholders.

The <mafClientReg> resource shall contain no child resources.

The <mafClientReg> resource shall contain the attributes specified in table 7.4-1.

Table 7.4-1: Attributes of <mafClientReg> resource

| Attributes of <mafClientReg> | Multiplicity | RW/RO/WO | Description |
|------------------------------|--------------|----------|--|
| resourceType | 1 | RO | See clause 9.6.1.3 of ETSI TS 118 101 [1]. |
| resourceID | 1 | RO | See clause 9.6.1.3 of ETSI TS 118 101 [1]. |
| resourceName | 1 | RO | See clause 9.6.1.3 of ETSI TS 118 101 [1]. |
| parentID | 1 | RO | See clause 9.6.1.3 of ETSI TS 118 101 [1]. |
| creationTime | 1 | RO | See clause 9.6.1.3 of ETSI TS 118 101 [1]. |
| labels | 1 | RW | See clause 9.6.1.3 of ETSI TS 118 101 [1]. |
| expirationTime | 1 | WO | See clause 9.6.1.3 of ETSI TS 118 101 [1]. |
| creator | 1 | WO | This attribute shall include the identifier of the MAF client which has created this resource. |
| adminFQDN | 1 | WO | FQDN of the M2M SP or MTE who is the administrating stakeholder of this enrolment. |
| assignedSymmKeyIID | 0..1 | RO | When the MAF Client uses a symmetric key to authenticate to the MAF, then the MAF may use this attribute to provide a symmetry key identifier within the domain of the MAF. Assigned by the MAF. |

7.5 Resource Type <mefClientReg>

The <mefClientReg> resource shall represent a MEF Client enrolled with an M2M SP or M2M Trust Enabler (MTE).

NOTE: A single MEF Client can be enrolled with at most one M2M SP and any number of MTEs (typically enabling end-to-end security to MEF Clients outside the MEF Client's M2M SP's domain). Consequently, a single MEF Client can be associated with multiple <mefClientReg> resources on multiple MEFs. It is also possible that a single MEF Client can be associated with multiple <mefClientReg> resources on a single MEF acting on behalf of multiple administrating stakeholders.

The <mefClientReg> resource shall contain no child resources.

The <mefClientReg> resource shall contain the child resources specified in table 7.5-1.

Table 7.5-1: Child resources of <mefClientReg> resource

| Child Resources of <mefClientReg> | Child Resource Type | Multiplicity | Description |
|-----------------------------------|---------------------|--------------|----------------|
| "cmd" | <mefClientCmd> | 1 | See clause 7.7 |

The <mefClientReg> resource shall contain the attributes specified in table 7.5-2.

Table 7.5-2: Attributes of <mefClientReg> resource

| Attributes of <mefClientReg> | Multiplicity | RW/RO/WO | Description |
|------------------------------|--------------|----------|--|
| resourceType | 1 | RO | See clause 9.6.1.3 of ETSI TS 118 101 [1]. |
| resourceID | 1 | RO | See clause 9.6.1.3 of ETSI TS 118 101 [1]. |
| resourceName | 1 | RO | See clause 9.6.1.3 of ETSI TS 118 101 [1]. |
| parentID | 1 | RO | See clause 9.6.1.3 of ETSI TS 118 101 [1]. |
| creationTime | 1 | RO | See clause 9.6.1.3 of ETSI TS 118 101 [1]. |
| labels | 1 | RW | See clause 9.6.1.3 of ETSI TS 118 101 [1]. |
| expirationTime | 1 | WO | See clause 9.6.1.3 of ETSI TS 118 101 [1]. |
| creator | 1 | WO | This attribute shall include the identifier of the MEF client which has created this resource. |
| adminFQDN | 1 | WO | FQDN of the M2M SP or MTE who is the administrating stakeholder of this enrolment. |
| assignedSymmKeyIID | 0..1 | RO | When the MEF Client uses a symmetric key to authenticate to the MEF, then the MEF may use this attribute to provide a symmetry key identifier within the domain of the MEF. Assigned by the MEF. |
| sourceIDs | 0..1 | RW | List of AE-IDs and CSE-IDs associated with a MEF client acting on behalf of a Node. This attribute shall be supplied if the creator attribute includes a Node-ID |

7.6 Resource Type <symmKeyReg>

The <symmKeyReg> resource shall represent a symmetric key that a source MAF Client or a source MEF Client has established with the MAF or MEF, respectively, for distributing to authorized Target MAF or MEF Clients and/or another MAF or MEF. The MAF or MEF Client provides a list of authorized Targets when the resource is created - the present document does not specify how the MAF or MEF associates the list with the resource. The MAF or MEF, in coordination with the identified administrating stakeholder (M2M SP or MTE), can modify the list of authorized Targets and the *expirationTime*.

The <symmKeyReg> resource shall contain no child resources.

The <symmKeyReg> resource shall contain the attributes specified in table 7.6-1.

Table 7.6-1: Attributes of <symmKeyReg> resource

| Attributes of <symmKeyReg> | Multiplicity | RW/RO/WO | Description |
|----------------------------|--------------|----------|---|
| resourceType | 1 | RO | See clause 9.6.1.3 of ETSI TS 118 101 [1]. |
| resourceID | 1 | RO | See clause 9.6.1.3 of ETSI TS 118 101 [1]. |
| resourceName | 1 | RO | See clause 9.6.1.3 of ETSI TS 118 101 [1]. This value is used as the relative part of the identifier for the symmetric key in security protocols. |
| parentID | 1 | RO | See clause 9.6.1.3 of ETSI TS 118 101 [1]. |
| creationTime | 1 | RO | See clause 9.6.1.3 of ETSI TS 118 101 [1]. |
| labels | 0..1 | RW | See clause 9.6.1.3 of ETSI TS 118 101 [1]. |
| expirationTime | 1 | WO | See clause 9.6.1.3 of ETSI TS 118 101 [1]. |
| creator | 1 | RO | See clause 9.6.1.3 of ETSI TS 118 101 [1]. |
| adminFQDN | 1 | WO | FQDN of the administrating stakeholder (M2M SP or MTE) associated with this enrolment. |
| SUID | 1 | WO | An SUID constraining the use of the symmetric key associated with this resource. |
| targetIDs | 1 (L) | RW | List of AE-ID(s) and/or CSE-ID(s) and/or and/or Node-ID(s) identifying the AE(s) and/or CSE(s) and/or Node(s) authorized to retrieve the resource. Only the creator and administrating stakeholder (identified by adminFQDN) are authorized to access this attribute. |

| Attributes of <symmKeyReg> | Multiplicity | RW/RO/WO | Description |
|----------------------------|--------------|----------|--|
| keyValue | 1 | WO | The value of the key to be provided to the identifier targets. May be provided in the Create request or derived by the MAF or MEF Client and MAF or MEF from the TLS handshake parameters. |

7.7 Resource Type <mefClientCmd>

A <mefClientCmd> resource includes instructions for the MEF client associated with the parent <mefClientReg> resource to be executed.

The <mefClientCmd> resource shall contain no child resources.

The <mefClientCmd> resource shall contain the attributes specified in table 7.7-1.

Table 7.7-1: Attributes of <mefClientCmd> resource

| Attributes of <mefClientCmd> | Multiplicity | RW/RO/WO | Description |
|------------------------------|--------------|----------|---|
| resourceType | 1 | RO | See clause 9.6.1.3 of ETSI TS 118 101 [1]. |
| resourceID | 1 | RO | See clause 9.6.1.3 of ETSI TS 118 101 [1]. |
| resourceName | 1 | RO | See clause 9.6.1.3 of ETSI TS 118 101 [1]. |
| parentID | 1 | RO | See clause 9.6.1.3 of ETSI TS 118 101 [1]. |
| creationTime | 1 | RO | See clause 9.6.1.3 of ETSI TS 118 101 [1]. |
| labels | 1 | RW | See clause 9.6.1.3 of ETSI TS 118 101 [1]. |
| expirationTime | 1 | WO | See clause 9.6.1.3 of ETSI TS 118 101 [1]. |
| cmdID | 1 | RW | This attribute shall include a MEF-assigned identifier of a command issued by the MEF. See clause 8.3.9.1 of [2] for further details. |
| cmdDescription | 1 | RO | This attribute provides the description of a command issued by the MEF to be executed by the MEF client. See clause 8.3.9.5 of [2] for further details. |
| cmdStatusCode | 1 | RW | This attribute shall be used for the status of the command issued by the MEF. See clause 8.3.9.6 of ETSI TS 118 103 [2] for further details. |

8 Resource-type specific procedures and definitions

8.1 Resource Type <MAFBase>

8.1.1 Introduction

A <MAFBase> resource shall represent a MAF. This <MAFBase> resource shall be the root for all the resources that are residing on the MAF.

Table 8.1.1-1: Data Type Definition of <MAFBase>

| Data Type ID | File Name | Note |
|--------------|------------------------|------|
| MAFBase | SEC-MAFBase-v2_1_0.xsd | |

The <MAFBase> resource has no resource-specific attributes.

Table 8.1.1-2: Child resources of <MAFBase> resource

| Child Resource Type | Child Resource Name | Multiplicity | Ref. to Resource Type Definition |
|---------------------|---------------------|--------------|----------------------------------|
| <mafClientReg> | [variable] | 0..n | Clause 7.4 |
| <symmKeyReg> | [variable] | 0..n | Clause 7.6 |

8.1.2 <MAFBase> resource specific procedures on CRUD operations

8.1.2.1 Create

Originator:

The <MAFBase> resource shall not be created via API.

Receiver:

Primitive specific operation on Recv-1.0 "Check the syntax of received message":

- 1) If the request is received, the MAF shall execute the following steps in order:
 - a) "Create an unsuccessful Response primitive" with the *Response Status Code* indicating "OPERATION_NOT_ALLOWED" error.
 - b) "Send the Response primitive".

8.1.2.2 Retrieve

Originator:

No change from the generic procedures in clause 7.2.2.1 of ETSI TS 118 104 [3] with clarifications discussed in clauses 5.1 and 6.

Receiver:

Same as the generic procedures in clause 7.2.2.2 of ETSI TS 118 104 [3] with clarifications discussed in clauses 5.1 and 6, and performing the following step in the place of step Recv-6.3: "Check authorization of the Originator":

The Receiver shall allow all Originator's to retrieve this resource.

8.1.2.3 Update

Originator:

The <MAFBase> resource shall not be updated via API.

Receiver:

Primitive specific operation on Recv-1.0 "Check the syntax of received message":

- 1) If the request is received, the MAF shall execute the following steps in order:
 - a) "Create an unsuccessful Response primitive" with the Response Status Code indicating "OPERATION_NOT_ALLOWED" error.
 - b) "Send the Response primitive".

8.1.2.4 Delete

Originator:

The <MAFBase> resource shall not be DELETED via API.

Receiver:

Primitive specific operation on Recv-1.0 "Check the syntax of received message":

- 1) If the request is received, the MAF shall execute the following steps in order:
 - a) "Create an unsuccessful Response primitive" with the *Response Status Code* indicating "OPERATION_NOT_ALLOWED" error.
 - b) "Send the Response primitive".

8.2 Resource Type <MEFBase>

8.2.1 Introduction

A <MEFBase> resource shall represent a MEF. This <MEFBase> resource shall be the root for all the resources that are residing on the MEF.

Table 8.2.1-1: Data Type Definition of <MEFBase>

| Data Type ID | File Name | Note |
|--------------|------------------------|------|
| MEFBase | SEC-MEFBase-v2_1_0.xsd | |

The <MEFBase> resource has no resource-specific attributes.

Table 8.2.1-2: Child resources of <MEFBase> resource

| Child Resource Type | Child Resource Name | Multiplicity | Ref. to Resource Type Definition |
|---------------------|---------------------|--------------|----------------------------------|
| <mefClientReg> | [variable] | 0..n | Clause 7.5 |
| <symmKeyReg> | [variable] | 0..n | Clause 7.6 |

8.2.2 <MEFBase> resource specific procedures on CRUD operations

8.2.2.1 Create

Originator:

The <MEFBase> resource shall not be created via API.

Receiver:

Primitive specific operation on Recv-1.0 "Check the syntax of received message":

- 1) If the request is received, the MEF shall execute the following steps in order:
 - a) "Create an unsuccessful Response primitive" with the *Response Status Code* indicating "OPERATION_NOT_ALLOWED" error.
 - b) "Send the Response primitive".

8.2.2.2 Retrieve

Originator:

No change from the generic procedures in clause 7.2.2.1 of ETSI TS 118 104 [3] with clarifications discussed in clauses 5.2 and 6.

Receiver:

Same as the generic procedures in clause 7.2.2.2 of [3] with clarifications discussed in clauses 5.2 and 6, and performing the following step in the place of step Recv-6.3: "Check authorization of the Originator":

- 1) The Receiver shall allow all Originator's to retrieve this resource.

8.2.2.3 Update

Originator:

The <MEFBase> resource shall not be updated via API.

Receiver:

Primitive specific operation on Recv-1.0 "Check the syntax of received message":

- 1) If the request is received, the MEF shall execute the following steps in order:
 - a) "Create an unsuccessful Response primitive" with the Response Status Code indicating "OPERATION_NOT_ALLOWED" error.
 - b) "Send the Response primitive".

8.2.2.4 Delete

Originator:

The <MEFBase> resource shall not be DELETED via API.

Receiver:

Primitive specific operation on Recv-1.0 "Check the syntax of received message":

- 1) If the request is received, the MEF shall execute the following steps in order:
 - a) "Create an unsuccessful Response primitive" with the *Response Status Code* indicating "OPERATION_NOT_ALLOWED" error.
 - b) "Send the Response primitive".

8.3 Resource Type <mafClientReg>

8.3.1 Introduction

A <mafClientReg> resource shall represent a MAF Client enrolled with the MAF on behalf of an M2M Service Provider or M2M Trust Enabler. A <mafClientReg> resource shall be a child resource of the MAF's <MAFBase> resource.

Table 8.3.1-1: Data Type Definition of <mafClientReg>

| Data Type ID | File Name | Note |
|--------------|-----------------------------|------|
| mafClientReg | SEC-mafClientReg-v2_1_0.xsd | |

Table 8.3.1-2: Universal/Common Attributes of <mafClientReg> resource

| Attribute Name | Request Optionality | |
|----------------|---------------------|--------|
| | Create | Update |
| @resourceName | NP | NP |
| resourceType | NP | NP |
| resourceID | NP | NP |
| parentID | NP | NP |
| creationTime | NP | NP |
| labels | O | O |
| expirationTime | M | M |
| creator | NP | NP |

Table 8.3.1-3: Resource Specific Attributes of <mafClientReg> resource

| Attribute Name | Request Optionality | | Data Type | Default Value and Constraints |
|-------------------|---------------------|--------|------------------|-------------------------------|
| | Create | Update | | |
| adminFQDN | M | NP | xs:anyURI | No default |
| assignedSymmKeyID | NP | NP | sec:credentialID | No default |

The <mafClientReg> resource shall contain no child resources.

8.3.2 <mafClientReg> resource specific procedures on CRUD operations

8.3.2.1 Create

This procedure is denoted *MAF Client Registration* in clause 8.8.2.3 of ETSI TS 118 103 [2]. The *To* parameter of the <mafClientReg> create request primitive includes the MAF-FQDN and the character "-" (dash) as a shorthand notation for the name of the <MAFBase> resource:

//{MAF-FQDN}/-/

EXAMPLE: //maf123.mafprovider.org/-/

The MAF-FQDN represents a globally unique identifier of a MAF (aka. MAF ID).

The *From* parameter of the <mafClientReg> create request primitive shall be left empty if the MAF client does not have a MAF Client ID assigned yet. If the MAF client interfaces with the MAF on behalf of the node (see clause 5.1.1), the Node-ID of the respective ADN, ASN, MN or IN shall serve as MAF Client ID.

Originator:

No change from the generic procedures in clause 7.2.2.1 of ETSI TS 118 104 [3] with clarifications discussed in clauses 5.1.2 and 6.2, and with following differences.

In step Orig-6.0: "Process Response primitive", if the Originator used a symmetric key to authenticate to the MAF, and the <mafClientReg> resource in the response contained an *assignedSymmKeyID* attribute then the originator shall use the *assignedSymmKeyID* attribute to identify this symmetric key when it is subsequently used in authenticating to the MAF.

Receiver:

Same as the generic procedures in clause 7.2.2.2 of [3] with clarifications discussed in clauses 5.1.2 and 6.2, and with following differences.

The Receiver shall perform the following steps in order in the place of Recv-6.3: "Check authorization of the Originator":

- 1) The Receiver shall determine if the Originator is authorized to register with the administrating stakeholder (M2M SP or MTE) identified by *adminFQDN* attribute. The present document does not specify how the Receiver makes this determination:
 - a) If the Originator is not authorized, then the Receiver shall execute the following steps in order:

- i) "Create an unsuccessful Response primitive" with the Response Status Code indicating "ACCESS_DENIED" error.
 - ii) "Send the Response primitive".
- b) If the Originator is authorized, then the Receiver shall allow the request.

The Receiver shall perform the following steps in order as part of "Create the resource" (clause 7.3.3.5 of ETSI TS 118 104 [3]) during Step Recv-6.5: "Create/Update/Retrieve/Delete/Notify operation is performed":

- 2) If the Originator authenticated using symmetric key with a key identifier which does not use the Receiver's FQDN, then:
 - a) The Receiver shall assign a symmetric key identifier with the Receiver's FQDN and with relative part which is unique within the scope of symmetric key identifiers issued by the Receiver. The Receiver shall associate this symmetric key identifier with the symmetric key used for authenticating the Originator.
 - b) The Receiver shall set the *assignedSymmKeyID* attribute to be the Credential-ID formed from the assigned symmetric key identifier as specified in clause 10.4 of ETSI TS 118 103 [2].
- 3) If the Originator authenticated using a symmetric key with a key identifier which does not use the Receiver's FQDN, or if the Originator authenticated using a certificate, then the Receiver shall not include an *assignedSymmKeyID* attribute in the created resource.
- 4) The Receiver shall assign the *creator* attribute to an AE-ID or CSE-ID or Node-ID on instructions from the administrating stakeholder. The present document does not specify any details of how the AE-ID or CSE-ID or Node-ID is determined.

8.3.2.2 Retrieve

This procedure is denoted *MAF Client Configuration Retrieval* in clause 8.8.2.4 of ETSI TS 118 103 [2]. This procedure is used to retrieve the *<mafClientReg>* resource.

Originator:

No change from the generic procedures in clause 7.2.2.1 of [3] with clarifications discussed in clauses 5.1.2 and 6.2.

Receiver:

Same as the generic procedures in clause 7.2.2.2 of [3] with clarifications discussed in clauses 5.1.2 and 6.2, performing the following steps in order in the place of Recv-6.3: "Check authorization of the Originator":

- 1) The Receiver shall determine if the Originator is authorized by checking if the Originator is the creator of the resource:
 - a) If the Originator is not authorized, then the Receiver shall execute the following steps in order:
 - i) "Create an unsuccessful Response primitive" with the Response Status Code indicating "ACCESS_DENIED" error.
 - ii) "Send the Response primitive".
 - b) If the Originator is authorized, then the Receiver shall allow the request.

8.3.2.3 Update

This procedure is denoted *MAF Client Configuration Update* in clause 8.8.2.5 of ETSI TS 118 103 [2]. This procedure is used to update attributes of the *<mafClientReg>* resource, such as e.g. labels, expiration time.

Originator:

The *<mafClientReg>* resource shall not be updated by a MAF client via API.

Receiver:

Same as the generic procedures in clause 7.2.2.2 of [3] with clarifications discussed in clauses 5.1.2 and 6.2, and with the following differences:

The Receiver shall perform the following step in the place of Recv-6.3: "Check authorization of the Originator":

- 1) The Receiver shall determine if the Originator is authorized by checking if the Originator is the creator of the resource:
 - a) If the Originator is not authorized, then the Receiver shall execute the following steps in order:
 - i) "Create an unsuccessful Response primitive" with the Response Status Code indicating "ACCESS_DENIED" error.
 - ii) "Send the Response primitive".
 - b) If the Originator is authorized, then the Receiver shall allow the request.

The Receiver shall perform the following step as part of "Update the resource" (clause 7.3.3.7 of [3]) during Step Recv-6.5: "Create/Update/Retrieve/Delete/Notify operation is performed":

- 2) If the Originator was the Creator of the resource, then the Receiver shall perform steps 2 and 3 in clause 8.3.2.1.

8.3.2.4 Delete

This procedure is denoted *MAF Client De-Registration* in clause 8.8.2.6 of ETSI TS 118 103 [2]. This procedure enables the MAF client to delete its own *<mafClientReg>* resource on a MAF.

Originator:

No change from the generic procedures in clause 7.2.2.1 of ETSI TS 118 104 [3] with clarifications discussed in clauses 5.1.2 and 6.2.

Receiver:

Same as the generic procedures in clause 7.2.2.2 of [3] with clarifications discussed in clauses 5.1.2 and 6.2, performing the following step in the place of Recv-6.3: "Check authorization of the Originator":

- 1) The Receiver shall determine if the Originator is authorized by checking if the Originator is the creator of the resource:
 - a) If the Originator is not authorized, then the Receiver shall execute the following steps in order:
 - i) "Create an unsuccessful Response primitive" with the Response Status Code indicating "ACCESS_DENIED" error.
 - ii) "Send the Response primitive".
 - b) If the Originator is authorized, then the Receiver shall allow the request.

8.4 Resource Type *<mefClientReg>*

8.4.1 Introduction

A *<mefClientReg>* resource shall represent a MEF Client enrolled with the MEF on behalf of an M2M Service Provider or M2M Trust Enabler. A *<mefClientReg>* resource shall be a child resource of the MEF's *<MEFBase>* resource.

Table 8.4.1-1: Data Type Definition of <mefClientReg>

| Data Type ID | File Name | Note |
|--------------|-----------------------------|------|
| mefClientReg | SEC-mefClientReg-v2_1_0.xsd | |

Table 8.4.1-2: Universal/Common Attributes of <mefClientReg> resource

| Attribute Name | Request Optionality | |
|----------------|---------------------|--------|
| | Create | Update |
| @resourceName | NP | NP |
| resourceType | NP | NP |
| resourceID | NP | NP |
| parentID | NP | NP |
| creationTime | NP | NP |
| labels | O | O |
| expirationTime | M | M |
| creator | NP | NP |

Table 8.4.1-3: Resource Specific Attributes of <mefClientReg> resource

| Attribute Name | Request Optionality | | Data Type | Default Value and Constraints |
|-------------------|---------------------|--------|------------------|-------------------------------|
| | Create | Update | | |
| adminFQDN | M | NP | xs:anyURI | No default |
| assignedSymmKeyID | NP | NP | sec:credentialID | No default |
| sourceIDs | O | NP | List of m2m:ID | No default |

Table 8.4.1-4: Child resources of <mefClientReg> resource

| Child Resource Type | Child Resource Name | Multiplicity | Ref. to Resource Type Definition |
|---------------------|---------------------|--------------|----------------------------------|
| <mefClientCmd> | "cmd" | 1 | Clause 7.7 |

8.4.2 <mefClientReg> resource specific procedures on CRUD operations

8.4.2.1 Create

This procedure is denoted *MEF Client Registration* in clause 8.3.5.2.3 of ETSI TS 118 103 [2]. The *To* parameter of the <mefClientReg> create request primitive includes the MEF-FQDN and the character "-" (dash) as a shorthand notation for the name of the <MEFBase> resource:

//{MEF-FQDN}/-

EXAMPLE: //mef123.mefprovider.org/-/

The MEF-FQDN represents a globally unique identifier of a MEF (aka. MEF ID).

The *From* parameter of the <mefClientReg> create request primitive shall be left empty if the MEF client does not have a MEF Client ID assigned yet. If the MEF client interfaces with the MEF on behalf of the node (see clause 5.2.1), the Node-ID of the respective ADN, ASN, MN or IN shall serve as MEF Client ID.

Originator:

No change from the generic procedures in clause 7.2.2.1 of ETSI TS 118 104 [3] with clarifications discussed in clauses 5.2.2 and 6.3, and with following differences:

In step Orig-6.0: "Process Response primitive", if the Originator used a symmetric key to authenticate to the MEF, and the <mefClientReg> resource in the response contained an *assignedSymmKeyID* then the originator shall use the *assignedSymmKeyID* to identify this symmetric key when it is subsequently used in authenticating to the MEF.

Receiver:

Same as the generic procedures in clause 7.2.2.2 of ETSI TS 118 104 [3] with clarifications discussed in clauses 5.2.2 and 6.3, and with following differences:

The Receiver shall perform the following steps in order in the place of Recv-6.3: "Check authorization of the Originator":

- 1) The Receiver shall determine if the Originator is authorized to register with the administrating stakeholder (M2M SP or MTE) identified by *fqdn* attribute. The present document does not specify how the Receiver makes this determination:
 - a) If the Originator is not authorized, then the Receiver shall execute the following steps in order:
 - i) "Create an unsuccessful Response primitive" with the Response Status Code indicating "ACCESS_DENIED" error.
 - ii) "Send the Response primitive".
 - b) If the Originator is authorized, then the Receiver shall allow the request.

The Receiver shall perform the following steps in order as part of "Create the resource" (clause 7.3.3.5 of [3]) during Step Recv-6.5: "Create/Update/Retrieve/Delete/Notify operation is performed":

- 2) If the Originator authenticated using symmetric key with a key identifier which does not use the Receiver's FQDN, then:
 - a) The Receiver shall assign a symmetric key identifier with the Receiver's FQDN and with relative part which is unique within the scope of symmetric key identifiers issued by the Receiver. The Receiver shall associate this symmetric key identifier with the symmetric key used for authenticating the Originator.
 - b) The Receiver shall set the *assignedSymmKeyID* attribute to be the Credential-ID formed from the assigned symmetric key identifier as specified in clause 10.4 of [2].
- 3) If the Originator authenticated using a symmetric key with a key identifier which does not use the Receiver's FQDN, or if the Originator authenticated using a certificate, then the Receiver shall not include an *assignedSymmKeyID* attribute in the created resource.
- 4) The Receiver shall assign the *creator* attribute to an AE-ID or CSE-ID or Node-ID on instructions from the administrating stakeholder. The present document does not specify any details of how the AE-ID or CSE-ID or Node-ID is determined.
- 5) The Receiver shall instantiate the *<mefClientCmd>* child resource.

8.4.2.2 Retrieve

This procedure is denoted *MEF Client Configuration Retrieval* in clause 8.3.5.2.4 of ETSI TS 118 103 [2]. This procedure is used to retrieve the *<mefClientReg>* resource.

Originator:

No change from the generic procedures in clause 7.2.2.1 of [3] with clarifications discussed in clauses 5.2.2 and 6.3.

Receiver:

Same as the generic procedures in clause 7.2.2.2 of [3] with clarifications discussed in clauses 5.2.2 and 6.3, performing the following steps in order in the place of Recv-6.3: "Check authorization of the Originator":

- 1) The Receiver shall determine if the Originator is authorized by checking if the Originator is the creator of the resource:
 - a) If the Originator is not authorized, then the Receiver shall execute the following steps in order:
 - i) "Create an unsuccessful Response primitive" with the Response Status Code indicating "ACCESS_DENIED" error.

- ii) "Send the Response primitive".
- b) If the Originator is authorized, then the Receiver shall allow the request.

8.4.2.3 Update

This procedure is denoted *MEF Client Configuration Update* in clause 8.3.5.2.5 of ETSI TS 118 103 [2]. This procedure is used to update attributes of the <*mefClientReg*> resource, such as e.g. labels, expiration time.

Originator:

The <*mefClientReg*> resource shall not be updated by a MEF client via API.

Receiver:

Same as the generic procedures in clause 7.2.2.2 of [3] with clarifications discussed in clauses 5.2.2 and 6.3, and with the following differences:

The Receiver shall perform the following step in the place of Recv-6.3: "Check authorization of the Originator":

- 1) The Receiver shall determine if the Originator is authorized by checking if the Originator is the creator of the resource:
 - a) If the Originator is not authorized, then the Receiver shall execute the following steps in order:
 - i) "Create an unsuccessful Response primitive" with the Response Status Code indicating "ACCESS_DENIED" error.
 - ii) "Send the Response primitive".
 - b) If the Originator is authorized, then the Receiver shall allow the request.

The Receiver shall perform the following step as part of "Update the resource" (clause 7.3.3.7 of ETSI TS 118 104 [3])" during Step Recv-6.5: "Create/Update/Retrieve/Delete/Notify operation is performed":

- 2) If the Originator was the Creator of the resource, then the Receiver shall perform steps 2 and 3 in clause 8.4.2.1.

8.4.2.4 Delete

This procedure is denoted *MEF Client De-Registration* in clause 8.3.5.2.6 of ETSI TS 118 103 [2]. This procedure enables the MEF client to delete its own <*mefClientReg*> resource on a MEF.

Originator:

No change from the generic procedures in clause 7.2.2.1 of [3] with clarifications discussed in clauses 5.2.2 and 6.3.

Receiver:

Same as the generic procedures in clause 7.2.2.2 of ETSI TS 118 104 [3] with clarifications discussed in clauses 5.2.2 and 6.3, performing the following step in the place of Recv-6.3: "Check authorization of the Originator":

- 1) The Receiver shall determine if the Originator is authorized by checking if the Originator is the creator of the resource:
 - a) If the Originator is not authorized, then the Receiver shall execute the following steps in order:
 - i) "Create an unsuccessful Response primitive" with the Response Status Code indicating "ACCESS_DENIED" error.
 - ii) "Send the Response primitive".
 - b) If the Originator is authorized, then the Receiver shall allow the request.

8.5 Resource Type <symmKeyReg>

8.5.1 Introduction

A <symmKeyReg> resource shall represent a symmetric key registered with a MAF or MEF and administrated by the identified administrating stakeholder. A <symmKeyReg> resource shall be a child resource of a <MAFBase> or a <MEFBase> resource.

Table 8.5.1-1: Data Type Definition of <symmKeyReg>

| Data Type ID | File Name | Note |
|--------------|----------------------------|------|
| symmKeyReg | SEC- symmKeyReg-v2_1_0.xsd | |

Table 8.5.1-2: Universal/Common Attributes of <symmKeyReg> resource

| Attribute Name | Request Optionality | |
|----------------|---------------------|--------|
| | Create | Update |
| @resourceName | NP | NP |
| resourceType | NP | NP |
| resourceID | NP | NP |
| parentID | NP | NP |
| creationTime | NP | NP |
| labels | O | O |
| creator | NP | NP |
| expirationTime | M | M |

Table 8.5.1-3: Resource Specific Attributes of <symmKeyReg> resource

| Attribute Name | Request Optionality | | Data Type | Default Value and Constraints |
|----------------|---------------------|--------|-----------------|-------------------------------|
| | Create | Update | | |
| adminFQDN | M | NP | xs:anyURI | No default |
| SUID | M | NP | m2m:suid | No default |
| targetIDs | O | O | m2m:listOfM2MID | No default |
| keyValue | O | NP | xs:hexBinary | No default |

The <symmKeyReg> resource shall contain no child resources.

8.5.2 <symmKeyReg> resource specific procedures on CRUD operations

8.5.2.1 Create

This procedure is denoted *MAF Key Registration* in clause 8.8.2.7 of ETSI TS 118 103 [2] and *MEF Key Registration* in clause 8.3.5.2.7 of ETSI TS 118 103 [2]. This procedure enables a Source MAF Client or a Source MEF Client to establish a symmetric key with the MAF or MEF, respectively, which can be retrieved for use by one or more Target MAF Clients or Target MEF Clients.

Originator:

No change from the generic procedures in clause 7.2.2.1 of ETSI TS 118 104 [3] with clarifications discussed in clauses 5.1.2 and 6.2 for Mmaf and in clauses 5.2.2 and 6.3 for Mmef, respectively, and with following differences:

In step Orig-1.0: "Compose of a Request primitive", the:

- 1) Originator shall select to either use a key derived from the TLS handshake or use another key provided by the Originator:
 - a) If the Originator selects to use a key derived from the TLS handshake, then the Originator shall not include the *keyValue* attribute in the <symmKeyReg> resource of the request.

- b) If the Originator selects to provide a key other than a key derived from the TLS handshake, the Originator shall include the value of this key in the *keyValue* attribute in the *<symmKeyReg>* resource of the request.

In step Orig-6.0: "Process Response primitive", the following steps shall be performed:

- 2) If the Originator selected to use a key derived from the TLS handshake (see difference to step Orig-1.0 above), then the Originator shall perform the following steps in order to generate the value for the *keyValue* attribute:
 - a) The Originator shall apply the TLS export mechanism described in clause 10.3.1 of ETSI TS 118 103 [2] to generate a TLS-export-key. For MAF Key Registration the "TLS Key Export Details for M2M Secure Connection Key", for MEF Key Registration the "TLS Key Export Details for Enrolment Key" apply, respectively.
 - b) The Originator shall apply the usage-constrained key derivation algorithm in clause 10.3.7 of ETSI TS 118 103 [2] to derive the *keyValue* from TLS-export-key, *adminFQDN*, *SUID* and the *resourceName* assigned by the Receiver to the created resource.
- 3) The originator shall record the *resourceName* attribute of the created resource as the relative part of the key identifier for the symmetric key which is to be assigned to the value for the *keyValue* attribute.

Receiver:

Same as the generic procedures in clause 7.2.2.2 of [3] with clarifications discussed in clauses 5.2 and 6, and with following differences:

The Receiver shall perform the following steps in order in the place of Recv-6.3: "Check authorization of the Originator":

- 1) The Receiver shall ensure that the following criteria are satisfied, with administrating stakeholder being the stakeholder matching the *adminFQDN* attribute of the *<symmKeyReg>* resource in the Create request:
 - a) The Originator is enrolled with the administrating stakeholder; that is, there is a non-expired *<mafClientReg>* resource whose *creator* attribute matches the Originator's AE-ID or CSE-ID or Node-ID, and whose *adminFQDN* attribute identifies the administrating stakeholder.
 - b) The Receiver determines that the administrating stakeholder allows the creation of the resource. The present document does not specify how the Receiver makes this determination.
- 2) If these criteria are not met, then the Receiver shall execute the following steps in order:
 - a) "Create an unsuccessful Response primitive" with the Response Status Code indicating "ACCESS_DENIED" error.
 - b) "Send the Response primitive".
- 3) Otherwise, then the Receiver shall allow the request.

The Receiver shall perform the following steps in order as part of "Create the resource" (clause 7.3.3.5 of ETSI TS 118 104 [3]) during Step Recv-6.5: "Create/Update/Retrieve/Delete/Notify operation is performed":

- 4) If the *keyValue* attribute is not present in the *<symmKeyReg>* resource in the request, then the Receiver shall perform the following step to generate the value for the *keyValue* attribute:
 - a) The Receiver shall apply the TLS export mechanism described in clause 10.3.1 of ETSI TS 118 103 [2] to generate a TLS-export-key.
 - b) The Receiver shall apply the usage-constrained key derivation algorithm in clause 10.3.7 of [2] to derive the value for the *keyValue* attribute from TLS-export-key, *adminFQDN*, *SUID* and the *resourceName* assigned by the Receiver to the created resource.

8.5.2.2 Retrieve

This procedure is denoted *MAF Key Retrieval* in clause 8.8.2.8 of ETSI TS 118 103 [2] and *MEF Key Retrieval* in clause 8.3.5.2.8 of ETSI TS 118 103. It enables a Target MAF Client to retrieve the Key Value from a MAF corresponding to a RelativeKeyID available to the Target MAF Client.

Originator:

No change from the generic procedures in clause 7.2.2.1 of ETSI TS 118 104 [3] with clarifications discussed in clauses 5.1.2 and 6.2 for Mmaf and in clauses 5.2.2 and 6.3 for Mmef, respectively.

Receiver:

Same as the generic procedures in clause 7.2.2.2 of [3] with clarifications discussed in clauses 5.2 and 6, and with following differences:

The Receiver shall perform the following step in the place of Recv-6.3: "Check authorization of the Originator":

- 1) The Receiver shall determine if the Originator is authorized by checking if the Originator is the creator of the resource or the Originator is identified in the *targetIDs*:
 - a) If the Originator is not authorized, then the Receiver shall execute the following steps in order:
 - i) "Create an unsuccessful Response primitive" with the Response Status Code indicating "ACCESS_DENIED" error.
 - ii) "Send the Response primitive".
 - b) If the Originator is authorized, then the Receiver shall allow the request.

8.5.2.3 Update

This procedure is denoted *MAF Key Registration Update* in clause 8.8.2.9 of ETSI TS 118 103 [2] and *MEF Key Registration Update* in clause 8.3.5.2.9 of ETSI TS 118 103. It enables a Source MAF Client or Source MEF Client to update the metadata associated with a registered key.

Originator:

No change from the generic procedures in clause 7.2.2.1 of [3] with clarifications discussed in clauses 5.1.2 and 6.2 for Mmaf and in clauses 5.2.2 and 6.3 for Mmef, respectively.

Receiver:

Same as the generic procedures in clause 7.2.2.2 of [3] with clarifications discussed in clauses 5.2 and 6, and performing the following step in the place of Recv-6.3: "Check authorization of the Originator":

- 1) The Receiver shall determine if the Originator is authorized by checking if the Originator is the creator of the resource:
 - a) If the Originator is not authorized, then the Receiver shall execute the following steps in order:
 - i) "Create an unsuccessful Response primitive" with the Response Status Code indicating "ACCESS_DENIED" error.
 - ii) "Send the Response primitive".
 - b) If the Originator is authorized, then the Receiver shall allow the request.

8.5.2.4 Delete

This procedure is denoted *MAF Key De-Registration* in clause 8.8.2.10 of ETSI TS 118 103 [2] and *MEF Key De-Registration* in clause 8.3.5.2.10 of ETSI TS 118 103. It enables a Source MAF Client to request the MAF to stop distributing the registered key.

Originator:

No change from the generic procedures in clause 7.2.2.1 of [3] with clarifications discussed in clause 5.1.2 and 6.2 for Mmaf and in clauses 5.2.2 and 6.3 for Mmef, respectively.

Receiver:

Same as the generic procedures in clause 7.2.2.2 of [3] with clarifications discussed in clauses 5.2 and 6, and performing the following step in the place of Recv-6.3: "Check authorization of the Originator":

- 1) The Receiver shall determine if the Originator is authorized by checking if the Originator is the creator of the resource:
 - a) If the Originator is not authorized, then the Receiver shall execute the following steps in order:
 - i) "Create an unsuccessful Response primitive" with the Response Status Code indicating "ACCESS_DENIED" error.
 - ii) "Send the Response primitive".
 - b) If the Originator is authorized, then the Receiver shall allow the request.

8.6 Resource Type <mefClientCmd>

8.6.1 Introduction

A <mefClientCmd> resource shall represent a command to be indicated to a MEF client by a MEF, and a status report on the attempted parsing and execution of that command to be indicated to the MEF by a MEF Client. The retrieve procedure and update procedure are used for this purpose.

Table 8.6.1-1: Data Type Definition of <mefClientCmd>

| Data Type ID | File Name | Note |
|--------------|-----------------------------|------|
| mefClientCmd | SEC-mefClientCmd-v2_1_0.xsd | |

Table 8.6.1-2: Universal/Common Attributes of <mefClientCmd> resource

| Attribute Name | Request Optionality |
|----------------|---------------------|
| | Update |
| @resourceName | NP |
| resourceType | NP |
| resourceID | NP |
| parentID | NP |
| creationTime | NP |
| labels | O |
| expirationTime | NP |

Table 8.6.1-3: Resource Specific Attributes of <mefClientCmd> resource

| Attribute Name | Request Optionality | Data Type | Default Value and Constraints |
|----------------|---------------------|--------------------|-------------------------------|
| | Update | | |
| cmdID | M | m2m:requestID | No default |
| cmdDescription | NP | sec:cmdDescription | No default |
| cmdStatusCode | M | sec:cmdStatusCode | No default |

The <mefClientCmd> resource shall contain no child resources.

8.6.2 <mefClientCmd> resource specific procedures on CRUD operations

8.6.2.1 Create

Originator:

The <mefClientCmd> resource shall not be created via API. It is instantiated by a MEF when the parent <mefClientReg> resource is created as described in clause 8.4.2.1.

Receiver:

The primitive specific operation on Recv-1.0 "Check the syntax of received message" defined in ETSI TS 118 104 [3] applies:

- 2) If the request is received, the Receiver CSE shall execute the following steps in order.
 - a) "Create an unsuccessful Response primitive" with the *Response Status Code* indicating "OPERATION_NOT_ALLOWED" error.
 - b) "Send the Response primitive".

8.6.2.2 Retrieve

This procedure is denoted *MEF Client Command Retrieval* in clause 8.3.9.2 of ETSI TS 118 103 [2]. This procedure is used to retrieve the <mefClientCmd> resource.

Originator:

No change from the generic procedures in clause 7.2.2.1 of [3] with clarifications discussed in clauses 5.2.2 and 6.3, and with following difference:

In step Orig-6.0: "Process Response primitive", the Originator shall extract the *cmdID*, *cmdDescription* and *cmdStatusCode* from the response and pass these to the MEF Client Command processing as specified in clause 8.3.9.2 in ETSI TS 118 103 [2].

Receiver:

Same as the generic procedures in clause 7.2.2.2 of [3] with clarifications discussed in clauses 5.2.2 and 6.3, and with following differences:

The Receiver shall perform the following in the place of Recv-6.3: "Check authorization of the Originator":

- 1) The Receiver shall determine if the Originator is authorized by checking if the Originator is the creator of the parent <mefClientReg> resource.
 - a) If the Originator is not authorized, then the Receiver shall execute the following steps in order.
 - i) "Create an unsuccessful Response primitive" with the Response Status Code indicating "ACCESS_DENIED" error.
 - ii) "Send the Response primitive".
 - b) If the Originator is authorized, then the Receiver shall allow the request.

The Receiver shall perform the following step as part of "Create the resource" (clause 7.3.3.5 of [2]) during Step Recv-6.5: "Create/Update/Retrieve/Delete/Notify operation is performed":

- 1) If the Receiver has a pending MEF Client Command to be issued to the Originator, then the Receiver shall set the *cmdID*, *cmdDescription* and *cmdStatusCode* attributes as specified in clause 8.3.9.2 of ETSI TS 118 103 [2]. The values of these attributes should remain set to these values until the MEF Client performs an Update on the Resource (see clause 8.6.2.3). If the MEF Client takes too long to perform an Update (for example, if the Response is not received by the Originator) then the MEF may choose to replace the attributes with a new MEF Client Command.

NOTE: The *cmdDescription* includes the *cmdClass* attribute which can be set to "NO_MORE_COMMANDS" by the MEF to indicate that there are no further commands to be issued.

8.6.2.3 Update

This procedure is denoted *MEF Client Command Update* in clause 8.3.9.3 of ETSI TS 118 103 [2]. This procedure is used by the MEF Client to report on the status of an issued MEF Client Command, and for an MEF to issue another MEF Client Command.

Originator:

No change from the generic procedures in clause 7.2.2.1 of [3] with clarifications discussed in clauses 5.2.2 and 6.3, and with following differences:

In step Orig-1.0: "Compose of a Request primitive", the Originator shall include the *cmdID* and *cmdStatusCode* attributes in the Content of the request, with attribute values assigned as described in clause 8.3.9.3 of ETSI TS 118 103 [2].

In step Orig-6.0: "Process Response primitive", the Originator shall extract the *cmdID*, *cmdDescription* and *cmdStatusCode* attributes from the response and pass these to the MEF Client Command processing specified in clause 8.3.9.3 in ETSI TS 118 103 [2].

Receiver:

Same as the generic procedures in clause 7.2.2.2 of [3] with clarifications discussed in clauses 5.2.2 and 6.3, and with the following differences:

The Receiver shall perform the following step in the place of Recv-6.3: "Check authorization of the Originator":

- 1) The Receiver shall determine if the Originator is authorized by checking if the Originator is the creator of the parent *<mefClientReg>* resource.
 - a) If the Originator is not authorized, then the Receiver shall execute the following steps in order.
 - i) "Create an unsuccessful Response primitive" with the Response Status Code indicating "ACCESS_DENIED" error.
 - ii) "Send the Response primitive".
 - b) If the Originator is authorized, then the Receiver shall allow the request.

The Receiver shall perform the following steps in order as part of "Update the resource" (clause 7.3.3.7) during Step Recv-6.5: "Create/Update/Retrieve/Delete/Notify operation is performed":

- 1) The Receiver shall extract the *cmdID* and *cmdStatusCode* attributes and pass these to the MEF Client Command processing in the MEF described in clause 8.3.9.3 of ETSI TS 118 103 [2].
- 2) If the Receiver has a pending MEF Client Command to be issued to the Originator, then the Receiver shall set the *cmdID*, *cmdDescription* and *cmdStatusCode* attributes as specified in clause 8.3.9.3 of ETSI TS 118 103 [2]. The values of these attributes should remain set to these values until the MEF Client performs a subsequent Update on the Resource. If the MEF Client takes too long to perform an Update (for example, if the Response is not received by the Originator) then the MEF may choose to replace the attributes with a new MEF Client Command.

NOTE: The *cmdDescription* includes the *cmdClass* attribute which can be set to "NO_MORE_COMMANDS" to indicate that there are no further commands to be issued.

8.6.2.4 Delete

Originator:

The *<mefClientCmd>* resource shall not be deleted via API. It is deleted by a MEF when the parent *<mefClientReg>* resource is deleted.

Receiver:

The primitive specific operation on Recv-1.0 "Check the syntax of received message" defined in ETSI TS 118 104 [3] applies:

- 1) If the request is received, the Receiver CSE shall execute the following steps in order.
 - a) "Create an unsuccessful Response primitive" with the *Response Status Code* indicating "OPERATION_NOT_ALLOWED" error.
 - b) "Send the Response primitive".

9 Short Names

9.1 Introduction

The short names are introduced in clause 8.2.1 of ETSI TS 118 104 [3]. The short names in ETSI TS 118 104 [3] shall apply in addition to the short names defined here.

9.2 Security-specific oneM2M Resource attributes

In protocol bindings resource attributes names shall be translated into short names of table 9.2-1 and in table 8.2.3-1 of ETSI TS 118 104 [3].

Table 9.2-1: Security-specific oneM2M Attribute Short Names

| Attribute Name | Occurs in | Short Name | Notes |
|---|--|----------------------|---------------------------------|
| <i>resourceType</i> | All | ty* | Defined in ETSI TS 118 104 [3]. |
| <i>resourceID</i> | All | ri* | Defined in ETSI TS 118 104 [3]. |
| <i>resourceName</i> | All | rn* | Defined in ETSI TS 118 104 [3]. |
| <i>parentID</i> | mafClientReg, mefClientReg, symmKeyReg | pi* | Defined in ETSI TS 118 104 [3]. |
| <i>expirationTime</i> | All | et* | Defined in ETSI TS 118 104 [3]. |
| <i>creationTime</i> | All | ct* | Defined in ETSI TS 118 104 [3]. |
| <i>labels</i> | mafClientReg, mefClientReg, symmKeyReg | lbl* | Defined in ETSI TS 118 104 [3]. |
| <i>creator</i> | mafClientReg, mefClientReg, symmKeyReg | cr* | Defined in ETSI TS 118 104 [3]. |
| <i>adminFQDN</i> | mafClientReg, mefClientReg, symmKeyReg | adfq | |
| <i>SUID</i> | symmKeyReg | suid | |
| <i>assignedSymmKeyID</i> | mafClientReg, mefClientReg | aski | |
| <i>targetIDs</i> | symmKeyReg | tgis | |
| <i>keyValue</i> | symmKeyReg | <b(kv< b=""></b(kv<> | |
| <i>cmdID</i> | mefClientCmd | mcci | |
| <i>cmdDescription</i> | mefClientCmd | mccd | |
| <i>cmdStatusCode</i> | mefClientCmd | mccs | |
| NOTE: Marked short names have been already assigned for primitive parameters or resource attributes in ETSI TS 118 104 [3]. | | | |

9.3 Security-specific oneM2M Resource types

In protocol bindings resource type names shall be translated into short names of table 9.3-1.

Table 9.3-1: Security-specific Resource Type Short Names

| Attribute Name | Short Name |
|---------------------|-------------|
| <i>MAFBase</i> | <i>maf</i> |
| <i>MEFBase</i> | <i>mef</i> |
| <i>mafClientReg</i> | <i>macr</i> |
| <i>mefClientReg</i> | <i>mecr</i> |
| <i>symmKeyReg</i> | <i>mkr</i> |
| <i>mefClientCmd</i> | <i>mcc</i> |

9.4 Security-specific oneM2M Complex data type members

In protocol bindings complex data types member names shall be translated into short names of table 9.4-1.

NOTE: The member names of the security configuration parameters *mefClientRegCfg*, *mafClientRegCfg*, *mefKeyRegCfg* and *mafKeyRegCfg* are defined in clause 12.4 of ETSI TS 118 103 [3].

Table 9.4-1: Security-specific oneM2M Complex data type member short names

| Member Name | Occurs in | Short Name | Notes |
|---------------------------|--|--------------|--------------------------------|
| <i>expirationTime</i> | <i>mefClientRegCfg</i> , <i>mefKeyRegCfg</i> , <i>mafClientRegCfg</i> , <i>mafKeyRegCfg</i> | <i>et*</i> | Defined in ETSI TS 118 104 [3] |
| <i>labels</i> | <i>mefClientRegCfg</i> , <i>mefKeyRegCfg</i> , <i>mafClientRegCfg</i> , <i>mafKeyRegCfg</i> | <i>lbl*</i> | Defined in ETSI TS 118 104 [3] |
| <i>fqdn</i> | <i>mefClientRegCfg</i> , <i>mefKeyRegCfg</i> , <i>mafClientRegCfg</i> , <i>mafKeyRegCfg</i> | <i>fq</i> | |
| <i>adminFQDN</i> | <i>mefClientRegCfg</i> , <i>mafClientRegCfg</i> | <i>adfq*</i> | |
| <i>httpPort</i> | <i>mefClientRegCfg</i> , <i>mafClientRegCfg</i> | <i>hpt</i> | |
| <i>coapPort</i> | <i>mefClientRegCfg</i> , <i>mafClientRegCfg</i> | <i>cpt</i> | |
| <i>websocketPort</i> | <i>mefClientRegCfg</i> , <i>mafClientRegCfg</i> | <i>wpt</i> | |
| <i>ppsk</i> | <i>mefClientRegCfg</i> , <i>mafClientRegCfg</i> | <i>pk</i> | |
| <i>rpsk</i> | <i>mefClientRegCfg</i> , <i>mafClientRegCfg</i> | <i>rk</i> | |
| <i>certAuth</i> | <i>mefClientRegCfg</i> , <i>mafClientRegCfg</i> | <i>cert</i> | |
| <i>credID</i> | <i>mefClientRegCfg</i> , <i>mafClientRegCfg</i> | <i>crdi</i> | |
| <i>caCerts</i> | <i>mefClientRegCfg</i> , <i>mafClientRegCfg</i> | <i>cact</i> | |
| <i>SUID</i> | <i>mefKeyRegCfg</i> , <i>mafClientRegCfg</i> , <i>authProfileMONodeArgs</i> | <i>suid*</i> | |
| <i>targetIDs</i> | <i>mefKeyRegCfg</i> , <i>mafClientRegCfg</i> | <i>tgis</i> | |
| <i>targetID</i> | <i>cmdDescription</i> | <i>tgi</i> | |
| <i>cmdClassID</i> | <i>cmdDescription</i> | <i>ccid</i> | |
| <i>cmdArgs</i> | <i>cmdDescription</i> | <i>cma</i> | |
| <i>certProvProtocolID</i> | <i>certProvCmdArgs</i> | <i>cppi</i> | |
| <i>URI</i> | <i>certProvCmdArgs</i> | <i>uri*</i> | |
| <i>certSubjectType</i> | <i>certProvCmdArgs</i> | <i>cst</i> | |
| <i>certSubjectID</i> | <i>certProvCmdArgs</i> | <i>csi</i> | |
| <i>deviceConfigURI</i> | <i>devCfgCmdArgs</i> | <i>dcu</i> | |
| <i>objectPath</i> | <i>MONodeCmdArgs</i> | <i>ajop*</i> | |

| Member Name | Occurs in | Short Name | Notes |
|------------------------|---------------|-------------|-------|
| objectTypeID | MONodeCmdArgs | <i>otyp</i> | |
| objectTypeSpecificArgs | MONodeCmdArgs | <i>otsa</i> | |
| retryDuration | noMoreCmdArgs | <i>rdu</i> | |
| noMoreCmdArgs | cmdArgs | <i>nmca</i> | |
| certProvCmdArgs | cmdArgs | <i>cpca</i> | |
| devCfgCmdArgs | cmdArgs | <i>dcca</i> | |
| MONodeCmdArgs | cmdArgs | <i>nnca</i> | |

NOTE: * marked short names have been already assigned to an attribute in table 9.2-1.

History

| Document history | | |
|-------------------------|-------------|-------------|
| V4.0.1 | August 2023 | Publication |
| | | |
| | | |
| | | |
| | | |