

ETSI TS 102 721-1 V1.2.1 (2013-08)



**Satellite Earth Stations and Systems (SES);
Air Interface for S-band Mobile Interactive Multimedia (S-MIM);
Part 1: General System Architecture and Configurations**

Reference

RTS/SES-00333

Keywords

architecture, configuration, MSS, satellite

ETSI

650 Route des Lucioles
F-06921 Sophia Antipolis Cedex - FRANCE

Tel.: +33 4 92 94 42 00 Fax: +33 4 93 65 47 16

Siret N° 348 623 562 00017 - NAF 742 C
Association à but non lucratif enregistrée à la
Sous-Préfecture de Grasse (06) N° 7803/88

Important notice

Individual copies of the present document can be downloaded from:

<http://www.etsi.org>

The present document may be made available in more than one electronic version or in print. In any case of existing or perceived difference in contents between such versions, the reference version is the Portable Document Format (PDF). In case of dispute, the reference shall be the printing on ETSI printers of the PDF version kept on a specific network drive within ETSI Secretariat.

Users of the present document should be aware that the document may be subject to revision or change of status. Information on the current status of this and other ETSI documents is available at

<http://portal.etsi.org/tb/status/status.asp>

If you find errors in the present document, please send your comment to one of the following services:

http://portal.etsi.org/chaicor/ETSI_support.asp

Copyright Notification

No part may be reproduced except as authorized by written permission.
The copyright and the foregoing restriction extend to reproduction in all media.

© European Telecommunications Standards Institute 2013.
All rights reserved.

DECT™, **PLUGTESTS™**, **UMTS™** and the ETSI logo are Trade Marks of ETSI registered for the benefit of its Members.
3GPP™ and **LTE™** are Trade Marks of ETSI registered for the benefit of its Members and of the 3GPP Organizational Partners.
GSM® and the GSM logo are Trade Marks registered and owned by the GSM Association.

Contents

| | |
|---|-----------|
| Intellectual Property Rights | 5 |
| Foreword..... | 5 |
| Introduction | 5 |
| 1 Scope | 6 |
| 2 References | 6 |
| 2.1 Normative references | 6 |
| 2.2 Informative references..... | 6 |
| 3 Definitions and abbreviations..... | 7 |
| 3.1 Definitions | 7 |
| 3.2 Abbreviations | 8 |
| 4 System Overview | 9 |
| 4.1 General | 9 |
| 4.2 User Services of the S-MIM System | 10 |
| 4.3 Mapping of Service Segments to Radio Interfaces..... | 11 |
| 4.4 Terminal Classes | 12 |
| 5 S-MIM Network Architecture | 13 |
| 5.1 S-MIM Segments | 13 |
| 5.2 S-MIM Interfaces | 14 |
| 6 Network Elements | 15 |
| 6.1 The User Terminals | 15 |
| 6.1.1 Terminals with Access to SS1 and/or SS2..... | 15 |
| 6.1.1.1 The Type C Terminal | 15 |
| 6.1.2 Terminals with Access to SS3 | 16 |
| 6.2 The Network Control Centre and the Satellite Hub..... | 21 |
| 6.2.1 The Satellite Hub | 21 |
| 6.2.2 The Network Control Centre | 25 |
| 6.3 The Complementary Ground Components..... | 26 |
| 6.3.1 The FWD CGC | 26 |
| 6.3.2 The RTN CGC..... | 27 |
| 7 Protocol Architecture | 31 |
| 7.1 Forward Link..... | 31 |
| 7.1.1 Forward Link Reference Protocol Stack..... | 31 |
| 7.1.2 Forward Link Protocol Architectures | 31 |
| 7.1.2.1 Satellite Link Only | 32 |
| 7.1.2.2 Satellite and/or FWD CGC | 32 |
| 7.2 Return Link | 33 |
| 7.2.1 Asynchronous Return Link Reference Protocol Stack..... | 33 |
| 7.2.2 Asynchronous Return Link Protocol Architectures | 34 |
| 7.2.2.1 Satellite Link Only | 34 |
| 7.2.2.2 Satellite and/or RTN CGC | 34 |
| 7.2.3 Synchronous Return Link Reference Protocol Stack..... | 35 |
| 7.2.4 Synchronous Return Link Protocol Architecture..... | 35 |
| Annex A (normative): Mapping of Services into Forward Link Physical Layer Channels | 37 |
| Annex B (informative): Network Architecture Configurations | 38 |
| Annex C (informative): The Service Enabling Platform..... | 40 |
| C.1 Server Side Middleware for SS1 and SS2..... | 40 |
| C.2 Server Side Middleware for SS3 | 41 |

| | | |
|-------------------------------|-------------------------------|-----------|
| Annex D (informative): | Management Plane | 43 |
| Annex E (informative): | Bibliography | 45 |
| History | | 46 |

Intellectual Property Rights

IPRs essential or potentially essential to the present document may have been declared to ETSI. The information pertaining to these essential IPRs, if any, is publicly available for **ETSI members and non-members**, and can be found in ETSI SR 000 314: *"Intellectual Property Rights (IPRs); Essential, or potentially Essential, IPRs notified to ETSI in respect of ETSI standards"*, which is available from the ETSI Secretariat. Latest updates are available on the ETSI Web server (<http://ipr.etsi.org>).

Pursuant to the ETSI IPR Policy, no investigation, including IPR searches, has been carried out by ETSI. No guarantee can be given as to the existence of other IPRs not referenced in ETSI SR 000 314 (or the updates on the ETSI Web server) which are, or may be, or may become, essential to the present document.

Foreword

This Technical Specification (TS) has been produced by ETSI Technical Committee Satellite Earth Stations and Systems (SES).

The present document is part 1 of a multi-part deliverable covering the Air Interface for S-band Mobile Interactive Multimedia (S-MIM), as identified below:

- Part 1: "General System Architecture and Configurations";**
- Part 2: "Forward Link Subsystem Requirements";
- Part 3: "Physical Layer Specification, Return Link Asynchronous Access";
- Part 4: "Physical Layer Specification, Return Link Synchronous Access";
- Part 5: "Protocol Specifications, Link Layer";
- Part 6: "Protocol Specifications, System Signalling".

Introduction

The S-MIM system specified herein is designed to provide:

- Interactive mobile broadcast services.
- Messaging services for handhelds and vehicular terminals, capable of serving millions of terminals due to a novel optimized air-interface in the return link.
- Real-time emergency services such as voice and file transfer, mainly addressing institutional users on-the-move such as fire brigades, civil protection, etc.

Inside the S-band, the 2 GHz MSS band is of particular interest for interactive multimedia, since it allows two-way transmission. Typically, the DVB-SH standard [i.8] is applied for broadcast transmission of user services; ESDR [i.6] or DVB-NGH [i.12] standards are other alternatives. Essential requirements under the R&TTE directive are covered by the harmonized standard EN 302 574 [i.3], [i.4] and [i.5].

The present document supersedes the previous version of the document and is recommended for new implementations. In case DVB-SH is used in the forward link, the changes with respect to the previous version are backward compatible.

The technology applied has been developed in the framework of the ESA funded project "DENISE" (ESTEC/Contract Number 22439/09/NL/US).

1 Scope

The present document specifies the S-MIM (S-band Mobile Interactive Multimedia) system in which a standardized S-band satellite mobile broadcast system is complemented by the addition of a return channel.

The present document is part 1 of the multi-part deliverable and defines the general S-band Mobile Interactive Multimedia (S-MIM) system architecture and configurations.

The other parts are listed in the foreword.

2 References

References are either specific (identified by date of publication and/or edition number or version number) or non-specific. For specific references, only the cited version applies. For non-specific references, the latest version of the referenced document (including any amendments) applies.

Referenced documents which are not found to be publicly available in the expected location might be found at <http://docbox.etsi.org/Reference>.

NOTE: While any hyperlinks included in this clause were valid at the time of publication ETSI cannot guarantee their long term validity.

2.1 Normative references

The following referenced documents are necessary for the application of the present document.

- [1] ETSI TS 102 721-2: "Satellite Earth Stations and Systems; Air Interface for S-band Mobile Interactive Multimedia (S-MIM); Part 2: Forward Link Subsystem Requirements".

2.2 Informative references

The following referenced documents are not necessary for the application of the present document but they assist the user with regard to a particular subject area.

- [i.1] ETSI TS 102 584: "Digital Video Broadcasting (DVB); DVB-SH Implementation Guidelines".
- [i.2] IEEE Journal on Selected Areas in Communications: "Bandlimited Quasi-Synchronous CDMA: A Novel Satellite Access Technique for Mobile and Personal Communications Systems". R. De Gaudenzi, C. Elia, R. Viola, 1992.
- [i.3] ETSI EN 302 574-1: "Satellite Earth Stations and Systems (SES); Harmonized standard for satellite earth stations for MSS operating in the 1 980 MHz to 2 010 MHz (earth-to-space) and 2 170 MHz to 2 200 MHz (space-to-earth) frequency bands; Part 1: Complementary Ground Component (CGC) for wideband systems: Harmonized EN covering the essential requirements of article 3.2 of the R&TTE Directive".
- [i.4] ETSI EN 302 574-2: "Satellite Earth Stations and Systems (SES); Harmonized standard for satellite earth stations for MSS operating in the 1 980 MHz to 2 010 MHz (earth-to-space) and 2 170 MHz to 2 200 MHz (space-to-earth) frequency bands; Part 2: User Equipment (UE) for wideband systems: Harmonized EN covering the essential requirements of article 3.2 of the R&TTE Directive".
- [i.5] ETSI EN 302 574-3: "Satellite Earth Stations and Systems (SES); Harmonized standard for satellite earth stations for MSS operating in the 1 980 MHz to 2 010 MHz (earth-to-space) and 2 170 MHz to 2 200 MHz (space-to-earth) frequency bands; Part 3: User Equipment (UE) for narrowband systems: Harmonized EN covering the essential requirements of article 3.2 of the R&TTE Directive".

- [i.6] ETSI EN 302 550 (all parts and sub-parts): "Satellite Earth Stations and Systems (SES); Satellite Digital Radio (SDR) Systems".
- [i.7] ETSI TS 102 824 (V1.1.1): "Digital Video Broadcasting (DVB); Remote Management and Firmware Update System for DVB IPTV Services (Phase 2)".
- [i.8] ETSI TS 102 585: "Digital Video Broadcasting (DVB); System Specifications for Satellite services to Handheld devices (SH) below 3 GHz".
- [i.9] ETSI TS 102 721-3: "Satellite Earth Stations and Systems; Air Interface for S-band Mobile Interactive Multimedia (S-MIM); Part 3: Physical Layer Specification, Return Link Asynchronous Access".
- [i.10] ETSI TS 102 721-4: "Satellite Earth Stations and Systems; Air Interface for S-band Mobile Interactive Multimedia (S-MIM); Part 4: Physical Layer Specification, Return Link Synchronous Access".
- [i.11] ETSI TS 102 721-5: "Satellite Earth Stations and Systems; Air Interface for S-band Mobile Interactive Multimedia (S-MIM); Part 5: Protocol Specifications, Link Layer".
- [i.12] DVB BlueBook A160: "Next Generation broadcasting system to Handheld, physical layer specification (DVB-NGH)".
- [i.13] ETSI TS 102 721-6: "Satellite Earth Stations and Systems; Radio interface for S-band Mobile Interactive Multimedia (S-MIM); Part 6: "Satellite Earth Stations and Systems; Air Interface for S-band Mobile Interactive Multimedia (S-MIM); Part 6: Protocol Specifications, System Signalling".

3 Definitions and abbreviations

3.1 Definitions

For the purposes of the present document, the following terms and definitions apply:

2 GHz MSS band: 1 980 MHz to 2 010 MHz (earth-to-space) and 2 170 MHz to 2 200 MHz (space-to-earth) frequency bands

NOTE: These paired bands are assigned to MSS.

architecture: abstract representation of a communications system

NOTE: Three complementary types of architecture are defined:

- Functional Architecture: the discrete functional elements of the system and the associated logical interfaces.
- Network Architecture: the discrete physical (network) elements of the system and the associated physical interfaces.
- Protocol Architecture: the protocol stacks involved in the operation of the system and the associated peering relationships.

collector: terrestrial components (Complementary Ground Component) that "collect" return link transmissions from terminals and forward them towards the ground segment

control plane: plane that has a layered structure and performs the access control and connection control functions; it deals with the signalling necessary to access to services, set up, supervise and release calls and connections

flow (of IP packets): traffic associated with a given connection-oriented, or connectionless, packet sequence having the same 5-tuple of source address, destination address, Source Port, Destination Port and Protocol type

management plane: plane that provides two types of functions, namely Layer Management and plane management functions:

- **plane management functions:** performs management functions related to a system as a whole and provides co-ordination between all the planes. Plane management has no layered structure
- **layer Management functions:** performs management functions relating to resources and parameters residing in its protocol entities

repeater: terrestrial components (Complementary Ground Component) that (mainly) repeat the satellite signal in the forward link

S-band: equivalent to 2 GHz MSS band

user plane: plane that has a layered structure and provides user information transfer, along with associated controls (e.g. flow control, recovery from errors, etc.)

3.2 Abbreviations

For the purposes of the present document, the following abbreviations apply:

| | |
|--------|--|
| 2G/3G | Second/Third generation mobile services, |
| AAA | Authentication, Authorization, Accounting |
| AuC | Authentication Centre |
| CAC | Call Admission Control |
| CDMA | Code Division Multiple Access |
| CDR | Call Detail Records |
| CGC | Complementary Ground Component |
| CWMP | Customer premises equipment WAN Management Protocol |
| DAMA | Dynamic Assignment Multiple Access |
| DVB-H | Digital Video Broadcasting, services to Handhelds |
| DVB-SH | Digital Video Broadcasting, Satellites services to Handhelds |
| EIRP | Equivalent Isotropic Radiated Power |
| ESDR | ETSI Satellite Digital Radio |
| ESG | Electronic Service Guide |
| ETSI | European Telecommunication Standards Institute |
| FLUTE | File Delivery Over Unidirectional Transport |
| FTP | File Transfer Protocol |
| FUS | Firmware Update System |
| FWD | Forward (link) |
| GEO | Geostationary Earth Orbit |
| GHz | Giga Hertz |
| GNSS | Global Navigation Satellite System |
| GPS | Global Positioning System |
| GSM | Global System for Mobile Communications |
| GW | GateWay |
| HLR | Home Location Register |
| HTTP | Hypertext Transfer Protocol |
| IC | Interference Cancellation/Interleaver Cycle |
| ID | Identifier |
| IETF | Internet Engineering Task Force |
| IKE | Internet Key Exchange |
| IMSI | International Mobile Subscriber Identity |
| IP | Internet Protocol |
| IPSec | IP Security |
| IPv4 | Internet Protocol version 4 |
| IPv6 | Internet Protocol version 6 |
| IS | Interface Satellite |
| ISDN | Integrated Services Digital Network |
| ITSP | Internet Telephony Service Provider |
| IU | Interleaver Unit/Interface User |
| LAN | Local Area Network |

| | |
|------------------|--|
| MMS | Multimedia Message Service |
| MPEG | Moving Pictures Experts Group |
| MPEG-TS | MPEG Transport Stream |
| MSS | Mobile Satellite Services |
| NCC | Network Control Centre/Non-Compressed Channel |
| NRT | Non-Real-time |
| OBU | On-Board Unit |
| PEP | Performance Enhancement Proxy |
| PHY | Physical Layer |
| PID | Program Identifier |
| PSI/SI | Program Specific Information/Service Information |
| PSTN | Public Switched telephone Network |
| QoS | Quality of Service |
| QS-CDMA | Quasi Synchronous CDMA |
| R&TTE | Radio and Telecommunications Terminal Equipment |
| RF | Radio Frequency |
| RFC | Request for Comment |
| RMS | Remote Management System |
| RT | Real-time |
| RTCP | Real-Time Control Protocol |
| RTN | Return (link) |
| RTP | Real-time Protocol |
| SDR | Satellite Digital Radio |
| SEL | Service Enabling Layer |
| SEP | Service Enabling Platform |
| SFN | Single Frequency Network |
| SIP | Session Initiation Protocol |
| SLR | SEP Location Register |
| S-MIM | S-band Mobile Interactive Multimedia |
| SMP | S-MIM Messaging Protocol |
| SMS | Short Message Service |
| SNMP | Simple Network Management Protocol |
| SOAP | Simple Object Access Protocol |
| SS | Subsystem |
| SS1 | Service Segment 1 |
| SS2 | Service Segment 2 |
| SS3 | Service Segment 3 |
| SSA | Spread Spectrum Aloha |
| SSM _x | Server Side Middleware for Service Segment x |
| TCP | Transmission Control Protocol |
| UDP | User Datagram Protocol |
| UMTS | Universal Mobile Telecommunications System |
| USIM | Universal Subscriber Identity Module |
| VLR | Visitor Location Register |
| VoIP | Voice over IP |
| WAN | Wide Area Network |

4 System Overview

4.1 General

An integrated satellite/terrestrial mobile system is described in the present document that provides interactive broadcast/multicast, data acquisition and two-way real-time services to subscribers. The S-band payload of a GEO satellite is assumed to provide communication links to users; however, non-GEO satellites are also compatible with this integrated system provided that Doppler pre-compensation countermeasures are put in place. Figure 4.1 shows an example of the system configuration.

NOTE: Satellites with payloads that are "transparent" to communication protocols (rather than "regenerative") are assumed throughout the present document.

On the forward link, a broadcast radio access interface shall be used according to the requirements specified in TS 102 721-2 [1].

On the return link, the radio interface is based on two non-exclusive options depending on the service required:

- 1) Asynchronous access using Spread Spectrum Aloha (SSA) random access.
- 2) Synchronous access using Quasi-synchronous Code Division Multiple Access (QS-CDMA) [i.2].

A number of terminals with different capabilities are foreseen to enable users to access different sets of services. Access to services may be complemented by terrestrial Complementary Ground Components (CGCs).

Ku-band feeder links are shown as examples of feeder links to the satellite S-band payload and the CGCs. In general the feeder links to the S-band satellite payload and the CGCs are independent, i.e. the same feeder link can be used, but also different feeder links can be used, even in different frequency bands. Furthermore, the CGC feeder link can also be implemented by terrestrial networks.

Although not shown in Figure 4.1, interconnection with 2G/3G and IP networks is also foreseen to extend the access of the user devices to services.

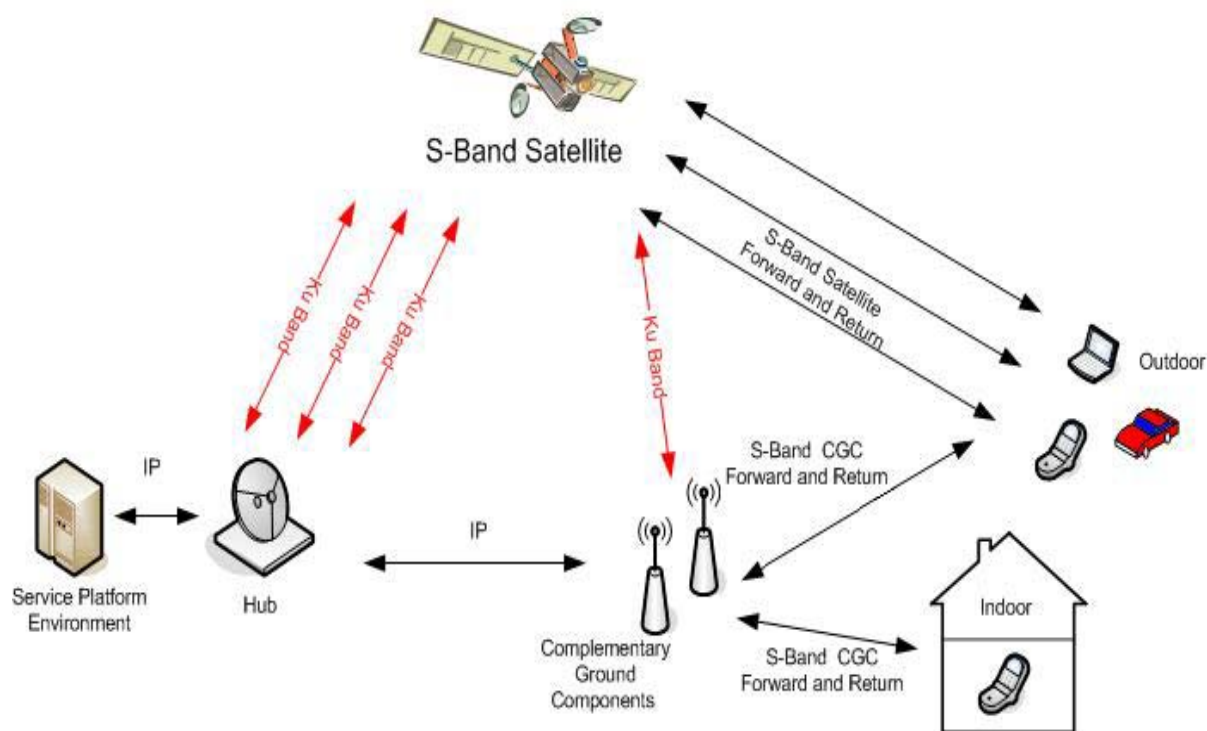

Figure 4.1: S-MIM System Elements

4.2 User Services of the S-MIM System

The S-MIM system provides three sets of user services: Service Segments 1, 2 & 3 (SS1, SS2, SS3), which can be provided concurrently and in different combinations.

Each Service Segment is defined by the inclusion of a number of services and service components each with similarities in their use of FWD and RTN links and in their QoS. Table 4.1 indicates the list of services that can be provided through S-MIM and their classification in terms of Service Segments.

Table 4.1: S-MIM Service Segments

| Service Segment 1 - Broadcast and Interactive Services | | |
|--|---------------------------------------|----------------|
| Service | Service Components | |
| One-way broadcast/multicast services | Streaming | |
| | Data distribution | |
| Interactive broadcast/multicast services | Interactive streaming | PayPerView |
| | | Televoting |
| | | Home-shopping |
| | Interactive data distribution | PayPerUse |
| | | Content repair |
| Service Segment 2 - Data Acquisition Services | | |
| Service | Service Components | |
| Messaging services | Vehicle telemetric | |
| | Environmental Monitoring | |
| Messaging Services in Combination with GNSS Applications | Anti-theft Services | |
| | Traffic Monitoring | |
| | Automatic Toll Payment | |
| | Distress Beacon | |
| | Interactive Distress Beacon | |
| SMS | - | |
| Service Segment 3 - Real-Time (Emergency) Services | | |
| Service | Service Components | |
| Public safety and emergency services | eCall | |
| | Two-way IP connection | |
| | Broadcast of Common Interest Messages | |
| Broadband for Professional Use | DSL-like connectivity | |

4.3 Mapping of Service Segments to Radio Interfaces

Given the different performance requirements of the services between SSs, the S-MIM system is designed so that in each SS the transport of a service is mapped into a suitable specific radio interface. The mapping of services into radio interfaces in the FWD and RTN links is shown in Figure 4.2, where two types of radio interface are shown in each case.

Accordingly, different configurations of the S-MIM system in terms of its FWD and RTN links will support one or several of the Service Segments indicated in clause 4.2.

FWD link capacity is shared between two profiles; a real-time (RT) profile and a non-real-time (NRT) profile. Flexible assignment between RT and NRT will allow most of the services to be offered when the RT profile is not available, although with (reduced) QoS guarantees of the NRT profile.

An overview of preferred and mandatory mappings of services into Forward Link Physical Layer Channels is shown in Annex A.

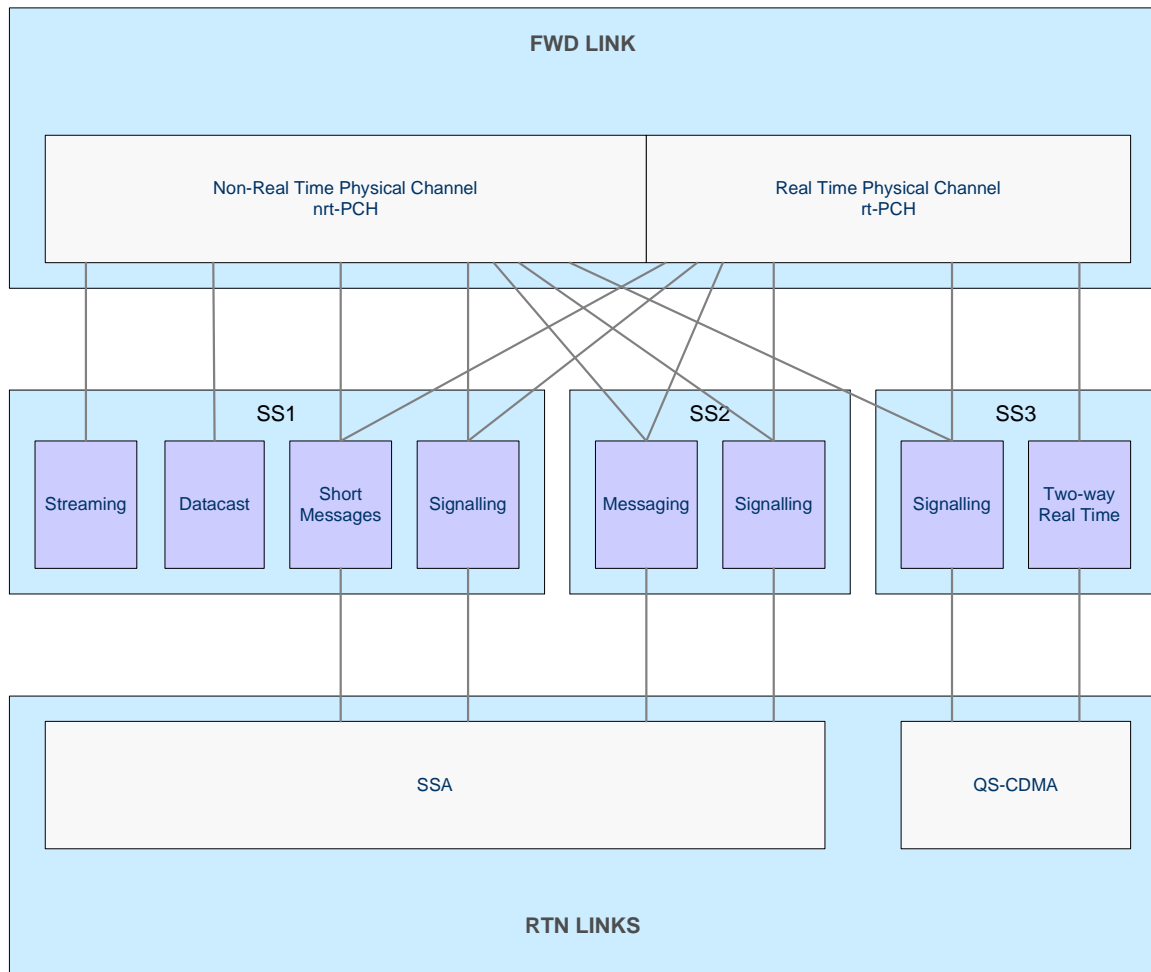

Figure 4.2: Mapping of Service Segments into available radio interfaces

4.4 Terminal Classes

The S-MIM terminal classes related to Service Segments, etc. are defined in Table 4.2. Further details, including the differences between Bx terminals, are available in Table 6.1.

Table 4.2: Overview of S-MIM Terminal Classes

| Terminal Class | Name | Service segments | Mobility |
|----------------|-----------|--------------------|------------|
| A | Handheld | 1, 2 | Mobile |
| B0 | Vehicular | 1, 2 | Mobile |
| B1 | | 2 | |
| B2 | | 1, 2 | |
| B3 | | 1, 2, 3 (see note) | |
| C | Specific | 1, 2, 3 (see note) | High speed |
| D | Emergency | 3 | Nomadic |
| E | Fixed | 3 | Fixed |
| F | Sensor | 2 | Fixed |

NOTE: Access to eCall service only, excluding all other SS3 services.

5 S-MIM Network Architecture

The S-MIM Network Architecture is a structured representation of the general S-MIM system introduced in clause 4.1, and is described in terms of its overall segments and interfaces.

The S-MIM Network Architecture as shown in Figure 5.1 is intended to be a modular system; some elements are mandatory for all configurations of the network, while others are optional and can be deployed incrementally to increase the performance and the service scope of the system, as described in Annex B. This figure also shows the boundaries of the S-MIM system including internal and external interfaces.

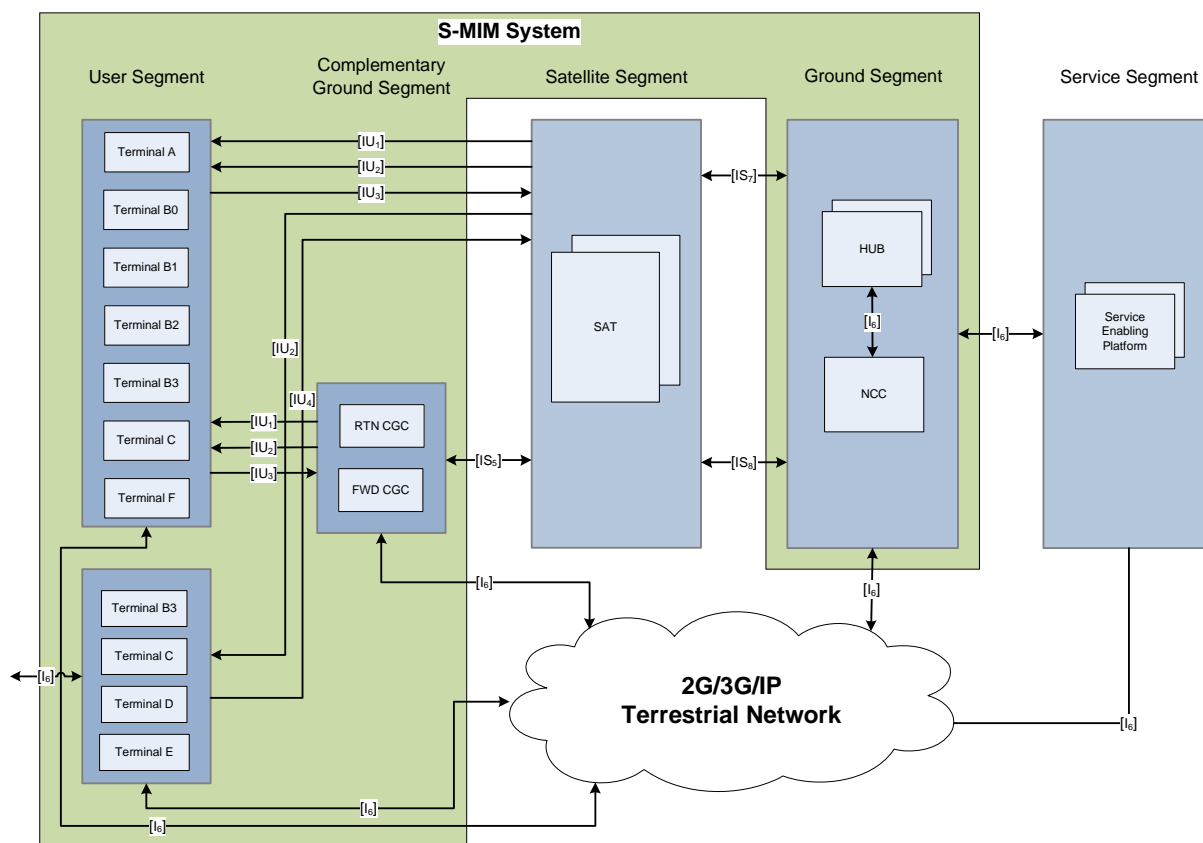

Figure 5.1: S-MIM Network Architecture - Network elements, interfaces and external segments

The Segments and the Interfaces shown above are described below.

Configurations of the above network architecture adapted to specific Service Segments are described in Annex B.

5.1 S-MIM Segments

The S-MIM system is composed of segments as follows:

- 1) User Segment: comprises all types of S-MIM user terminals.
- 2) Complementary Ground Segment: comprises CGCs that provide enhanced terrestrial coverage and capacity. The two types of CGCs are:
 - Forward CGC's (Repeater) repeat the satellite signal in the forward link. They are mainly used to complement the coverage area of the satellite in shadowed areas (e.g. urban areas) for the forward link signal. Repeaters can also be used to increase the local capacity of the network in the forward direction by broadcasting local/regional content not broadcast from the satellite.

- Return's CGC (Collector) "collect" return link transmissions from terminals and forward them towards the ground segment. Collectors can be used to increase coverage in areas where line-of-sight with satellite is limited. Collectors shall be co-located with repeaters in order to allow signalling in the forward downlink to announce the existence of the collector and its access configuration to the terminals in their coverage area.
- 3) Satellite Segment: composed of one or several satellites with S-band payloads. Additionally, one or more C, Ku or Ka-band satellites may also act as feeder links for the CGCs, although IP-based terrestrial networks could also be used.

NOTE 1: Specification of the satellite segment is out of scope of S-MIM.

- 4) Ground Segment: comprises one or several hubs and the NCC.
- The Hub manages transmissions in the forward and return satellite links, as well as in the forward and return CGCs, and subscribers at system level. It also interfaces with the service centres and other networks (2G/3G, IP). A hub manages one or more satellite beams; in general, one hub per satellite beam can be assumed.
 - The NCC is a "master" Hub with additional functionalities to manage configurations and policies of other hubs. The NCC is also responsible for satellite configuration management (out of scope of S-MIM).
- 5) Service Segment: comprises service-enabling functions.

NOTE 2: The specification of the Service Segment is out of scope of the S-MIM system.

Within each segment, the component elements are shown in Figure 5.1 and described in clause 6.

The interfaces between Segments and between S-MIM and external networks are summarized below.

5.2 S-MIM Interfaces

The system uses a number of interfaces (numbered from 1 to 7) between system elements for the terminals to communicate (through the satellite and the CGCs) with the ground segment. The interfaces indicated in Figure 5.1 are listed below:

Internal Interfaces:

- Interface {IU1}: minimum interface (user) forward link (with broadcast capabilities);
- Interface {IU2}: interface (user) forward link with broadcast capabilities and real-time access;

NOTE 1: Interfaces {IU1} and {IU2} are mutually exclusive in the same satellite payload: interface {IU2} is an upgrade of interface {IU1}. Different satellite payloads should support any of the two interfaces independently.

NOTE 2: Interface {IU2} has in fact two possible physical sub-interfaces: the non-real-time profile {IU2a} and the real-time profile {IU2b}.

- Interface {IU3}: interface (user) return link with asynchronous access (SSA);
- Interface {IU4}: interface (user) return link with synchronous access (QS-CDMA);

Interfaces to external elements:

NOTE 3: These interfaces are out of scope of the S-MIM specification.

- Interface {IS5}: interface (satellite) - between satellite and CGC (to be specified by the satellite operator e.g. Ku-band or other);
- Interface {I6}: generic IP interface, including communication with end-user devices;
- Interface {IS7}: interface (satellite) - between satellite and Hub intended for traffic to user terminals (to be specified by the satellite operator e.g. Ku-band or other);

- Interface {IS8}: interface (satellite) - between satellite and Hub, intended for traffic to CGC's (to be specified by the satellite operator e.g. Ku-band or other).

6 Network Elements

This clause describes the S-MIM network elements in terms of:

- The User Terminals.
- The Network Control Centre and the Satellite Hub.
- The Complementary Ground Components.

6.1 The User Terminals

The S-MIM system includes several user terminal classes with different capabilities in terms of performance, mobility and accessible Service Segments, requiring different access technology and service-specific functions. Terminal characteristics are defined in Table 6.1.

For all these terminals, specific requirements for the Forward Link Subsystem, Return Link Asynchronous/Synchronous Access, Link Layer and Control Plane apply and are given respectively in Parts 2 [1], 3 [i.9], 4 [i.10], 5 [i.11] and 6 [i.13] of this multi-parts deliverable.

6.1.1 Terminals with Access to SS1 and/or SS2

Terminals A, B0, B1, B2, B3, C and F can access SS1 and SS2. The baseline configuration of these terminals is shown in Figure 6.1.

Such terminals shall be equipped with radio interfaces to access SS1 and SS2 services in the FWD and RTN links, as per TS 102 721-2 [1]. The terminals may be equipped with a GPS receiver or other positioning device (e.g. any GNSS receiver, GSM/UMTS phone, or even WiFi enabled terminal) to assist the S-MIM control plane to perform mobility management.

Terminal B3 is similar to B1/B2 terminals but with additional access as described in clause 6.1.2 (to the eCall service which belongs to SS3 and can only be accessed if the QS-CDMA radio access is also available at the terminal). Therefore, the complete functional description of terminal B3 is achieved by merging Figure 6.1 with Figure 6.3 (except the features related to terminals D and E only).

6.1.1.1 The Type C Terminal

Terminal C is a special case of SS1/2 terminal (see Figure 6.2) and its scope is twofold:

- 1) it shall be capable of transmitting and receiving in the S-band (as for terminals A, Bx and F), but with higher speed mobility;
- 2) it shall act as gap filler to allow other devices to access the S-band services in a vehicle (for example train or aircraft).

Therefore the terminal C is similar to terminals A, Bx and F, but the application layer within the user device should only contain network management functions, as the user data will be directly routed by the IP layer router at the IP Suite SS towards the IP SS (with 802.11x or Ethernet access).

The IP traffic received from the IP SS through its uplink will be routed by the IP router at the IP Suite SS towards the S-Band SS Link layer to encapsulate it according to the S-band SS waveform and transmit it over the S-band radio interface (SSA in this case).

For the eCall service option, the functionalities shall be extended to include QS-CDMA radio interface, link layer (user and control planes) and the indicated functions for C terminals in Figure 6.3 in IP and application layers.

6.1.2 Terminals with Access to SS3

Terminals B3, C, D and E access SS3 services. A functional diagram of their architecture is shown in Figure 6.3.

As a part of service-enabling platform, SS3 compliant terminals shall have functional elements which are part of the OSM3 (OBU Side Middleware), to enable users to perform or receive VoIP calls and to access data information located on Intranets or Internet.

Table 6.1: S-MIM Terminal classes

| Terminal Class | A | B0 | B1 | B2 | B3 | C | D | E | F |
|---|-------------------|--------------------------------|------------------------------|---------------|------------------|--|--|--|---|
| Name | Handheld | Vehicular | | | | Specific | Emergency | Fixed | Sensor |
| Service segments | 1, 2 | 1, 2 | 2 | 1, 2 | 1, 2, 3 (note 1) | 1, 2, 3 (note 1) | 3 | 3 (note2) | 2 |
| Mobility | Mobile | Mobile | | | | High speed | Nomadic | Fixed | Fixed |
| Supported bit rate (FWD/RTN) | Medium/Low | Medium/Low | Low/Medium | Medium/Medium | Medium/Medium | High/High | High/High | High/High | Low/Medium |
| Power Class (note 4) | 1bis | 1bis | 1bis | 1bis | 1 | 1 | 1 | 1 | 1bis |
| Tolerance (note 5) | +1/-3 dB | +1/-3 dB | +1/-3 dB | +1/-3 dB | +2,7/-2,7 dB | +2,7/-2,7 dB | +2,7/-2,7 dB | +2,7/-2,7 dB | +1/-3 dB |
| Nominal EIRP | 2 dBW | 2 dBW | 5 dBW | 5 dBW | 11 dBW | 15 dBW | 15 dBW | 15 dBW | 5 dBW |
| Antenna performance (G/T) (note 3) | Low -29 dB/K | Low -25 dB/K to -24 dB/K | Medium -21 dB/K | | | High ≥-21 dB/K | High ≥-21 dB/K | High ≥-21 dB/K | Medium -21 dB/K |
| Access to CGCs | Yes | Yes | Yes | | | Yes | No | No | Yes |
| Power supply | Battery | Battery | Power supply from vehicle | | | Power supply from vehicle | Power supply from vehicle or portable generator | Local power network or power units | Local power network, power units or batteries |
| Other details | Consumer Terminal | Consumer Terminal | Terminal embedded in vehicle | | | Collective Terminal installed in fast moving vehicle | Professional (collective) Terminal for emergency operators | Collective terminal Size of typical set-top-box | Sensor network terminal |
| NOTE 1: eCall only. | | | | | | | | | |
| NOTE 2: No emergency services, only broadband access. | | | | | | | | | |
| NOTE 3: Handheld terminals belong to category 2b in [i.1]; vehicular terminals to category 1; nomadic and fixed terminal having at least the G/T performance of category 1 or better, assuming the antenna is constantly pointed towards the satellite. | | | | | | | | | |
| NOTE 4: Power Classes are compliant with [i.4]. | | | | | | | | | |
| NOTE 5: Tolerance refers to the maximum output power as in [i.4] and not to the accuracy in setting the actual output power. | | | | | | | | | |

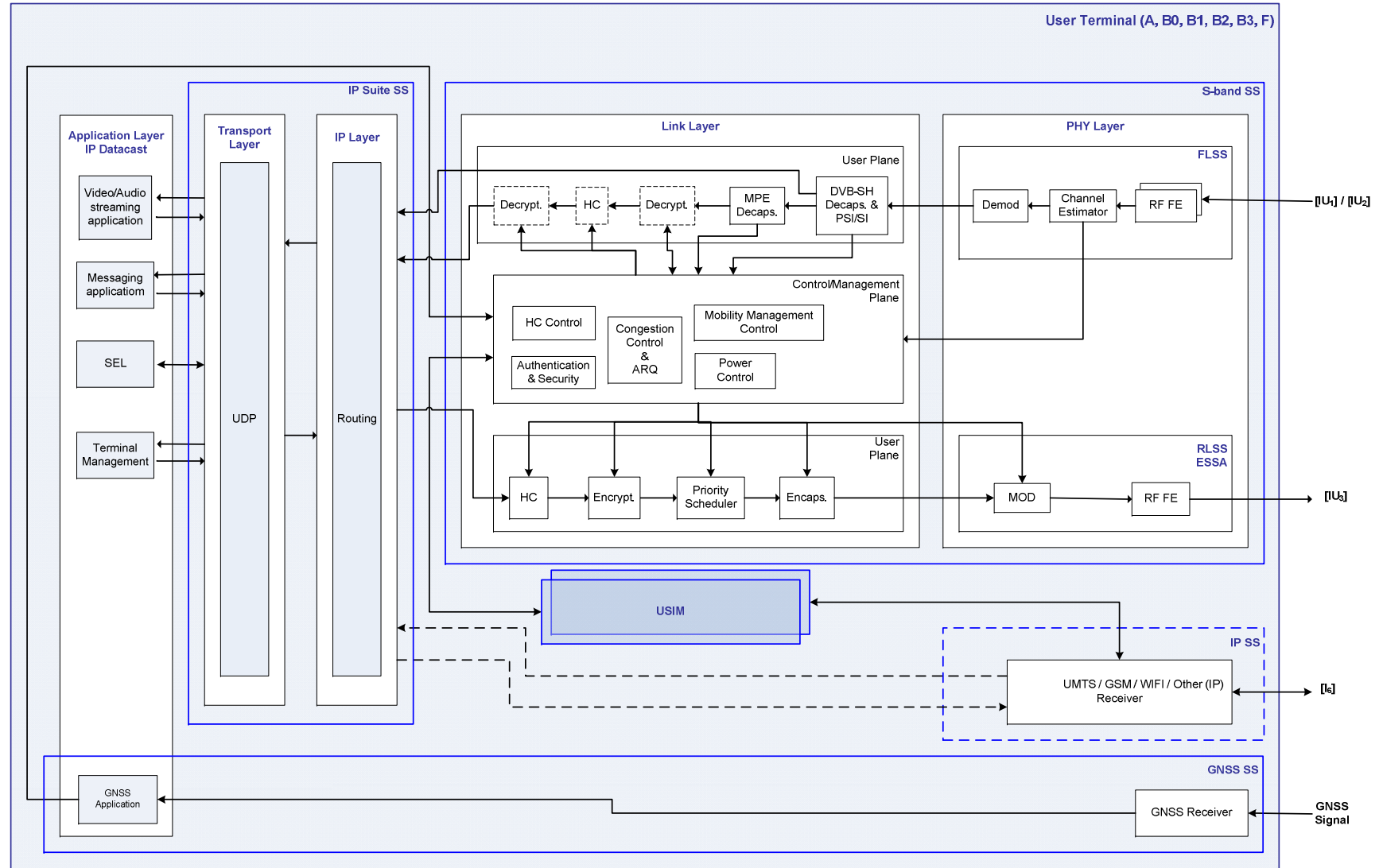

Figure 6.1: Functional diagram of the SS1/SS2 user terminal

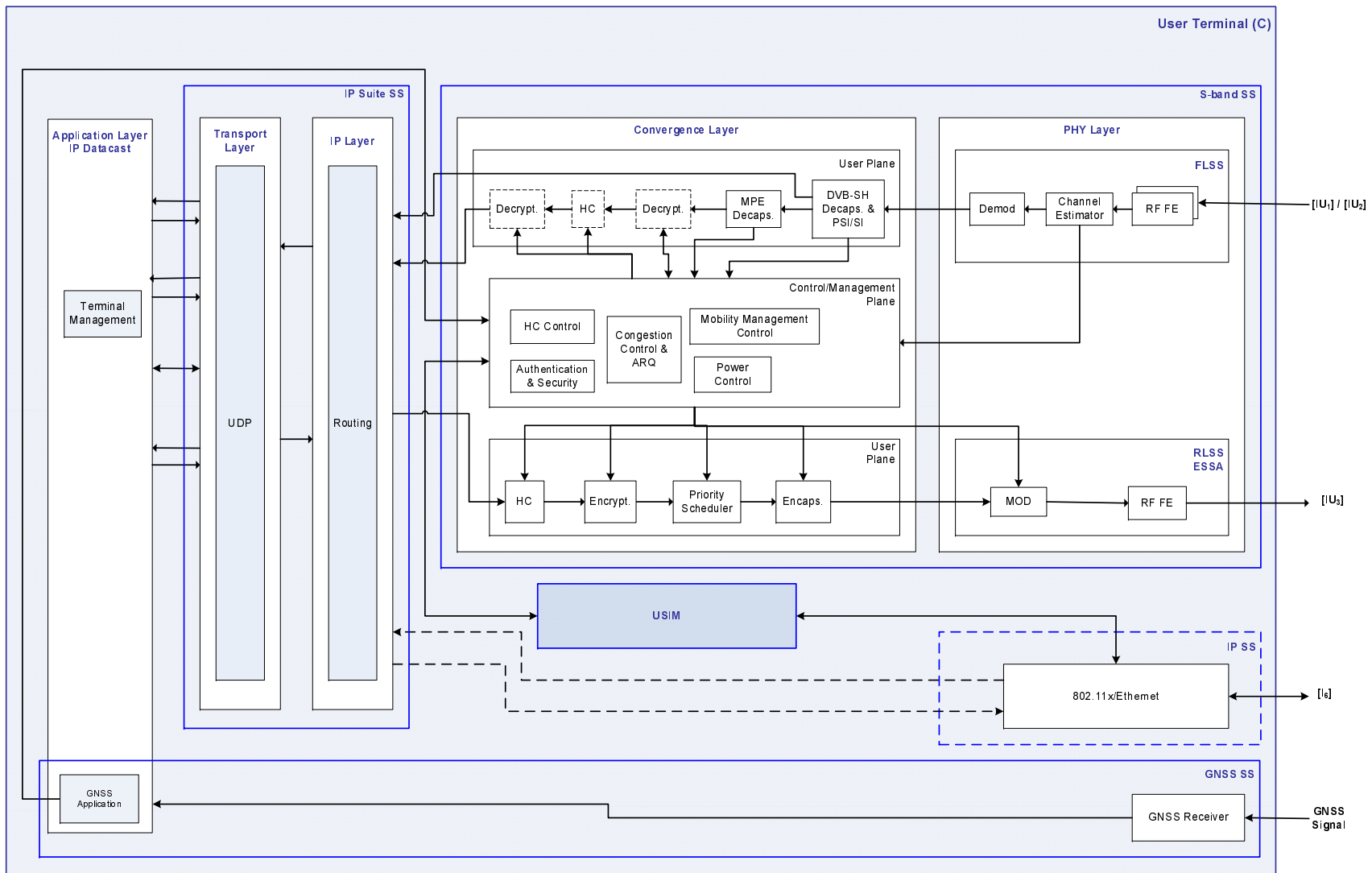

Figure 6.2: Functional diagram of the user terminal - Type C with access to SS1/SS2 only

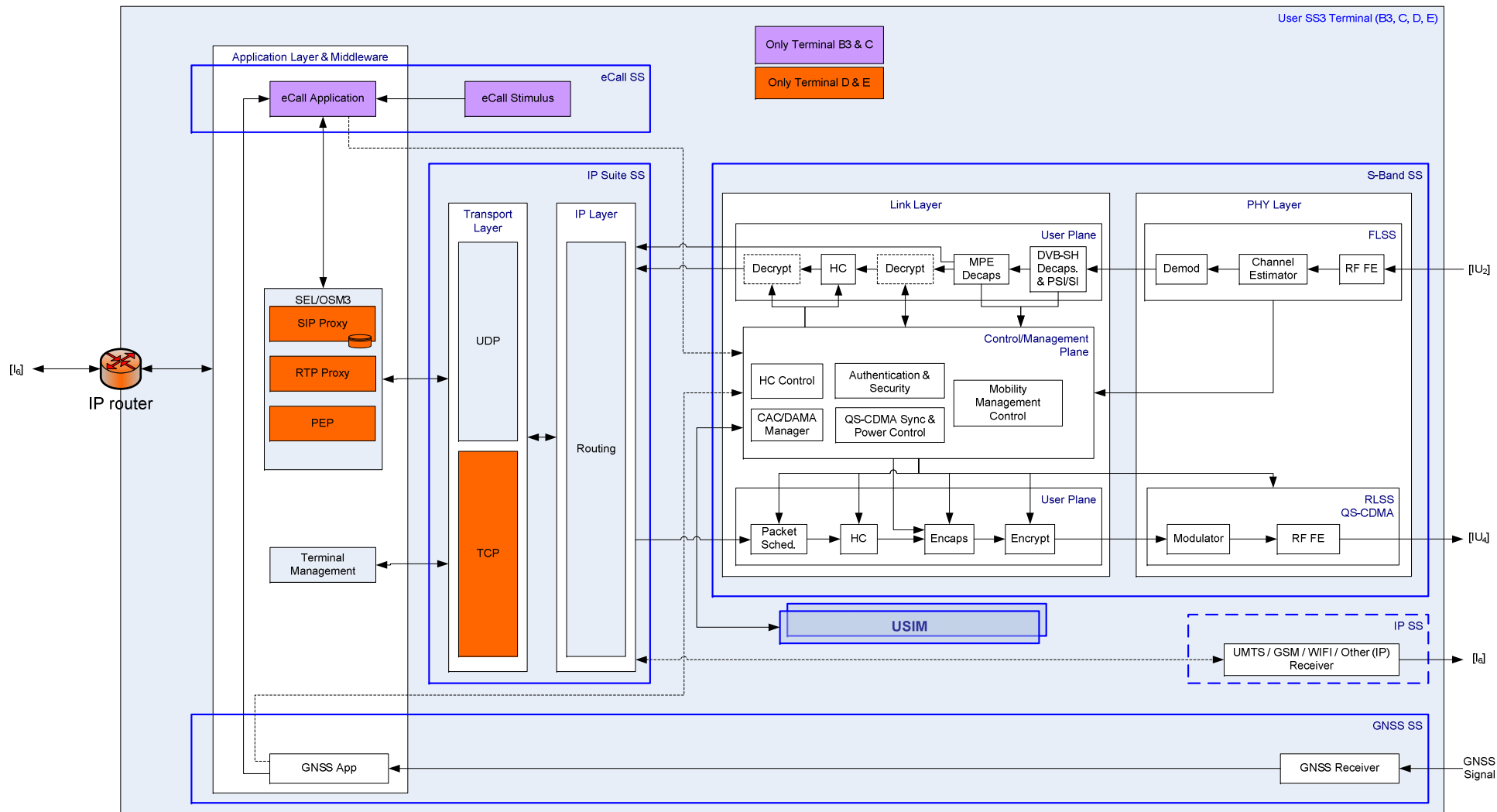

Figure 6.3: Functional diagram of the SS3 user terminal

6.2 The Network Control Centre and the Satellite Hub

The Network Control Centre (NCC) manages the complete S-MIM network. However, the management of the complete S-MIM network may be distributed, considering that within each service area a different set of services may be offered. With a distributed approach, the NCC functions to manage transmission/reception will be distributed in satellite hubs. In particular, a satellite hub manages one service area; a service area refers to the geographical area covered by one or several satellite beams. Therefore, the hub managing one service area in practice manages transmissions (in FWD and RTN links) through the corresponding satellite beam(s) and the CGCs located within the coverage area of that (or those) satellite beam(s).

Depending on the satellite operator requirements, two possible options are considered for the topology of the hubs network, as can be seen in Figure 6.4:

- Fully meshed hub network: all hubs are interconnected.
- Hierarchical meshed topology: all hubs are interconnected, while one hub has additional functionalities to manage the rest of hubs. This hub with network wide management functionalities will be called Network Control Centre (NCC).

In the meshed topology, each hub manages independently its service area (beam or set of beams); hubs are interconnected for routing purposes and mobility management (especially for the support of roaming); one of the hubs has also Network Control Centre functionalities, referring to the management of the S-band satellite. In the hierarchical topology, the NCC has the role of a "master hub" that, in addition to the hub functionalities and the management of the satellite, can manage specific aspects of the rest of hub's operation.

The functional description of the regular hub in the meshed topology or all hubs other than the NCC in the hierarchical meshed topology is provided in clause 6.2.1; the additional functionalities to be fulfilled by the NCC (or master hub) of the hierarchical meshed topology is provided in clause 6.2.2.

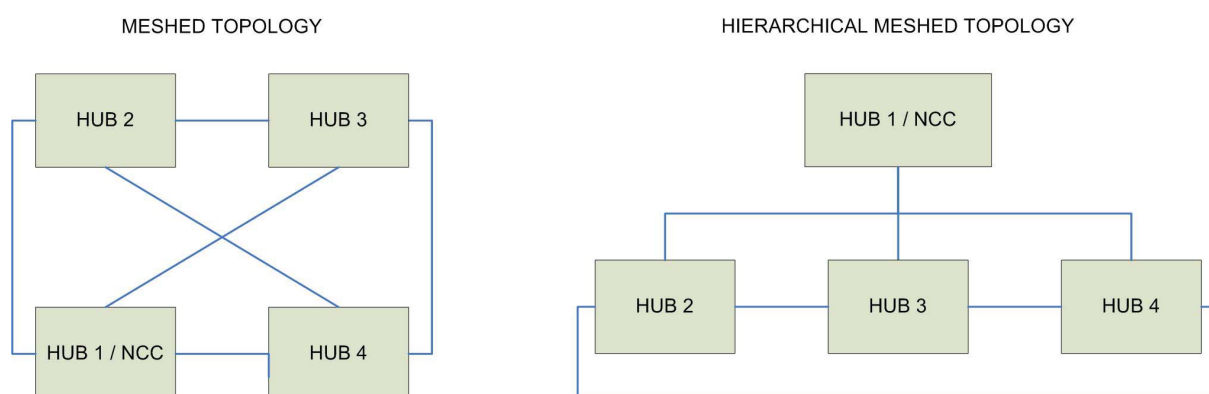

Figure 6.4: NCC/Hub network topologies

6.2.1 The Satellite Hub

The hub implements a number of subsystems and functions as shown in Figure 6.5, and as described in Table 6.2.

The functional description of the hub corresponds to any of the hubs in the meshed topology or all hubs other than the NCC in the hierarchical meshed topology. In the particular case of the meshed topology, the hub operates independently of other hubs, and hence all local configurations and decision policies (called NCC policies in Figure 6.5) are generated and managed locally. In the case of the hierarchical meshed topology, the hub is interconnected to a master hub (or NCC) which manages the configuration of each hub and generates the NCC decision policies to be implemented in the hub through network management protocols.

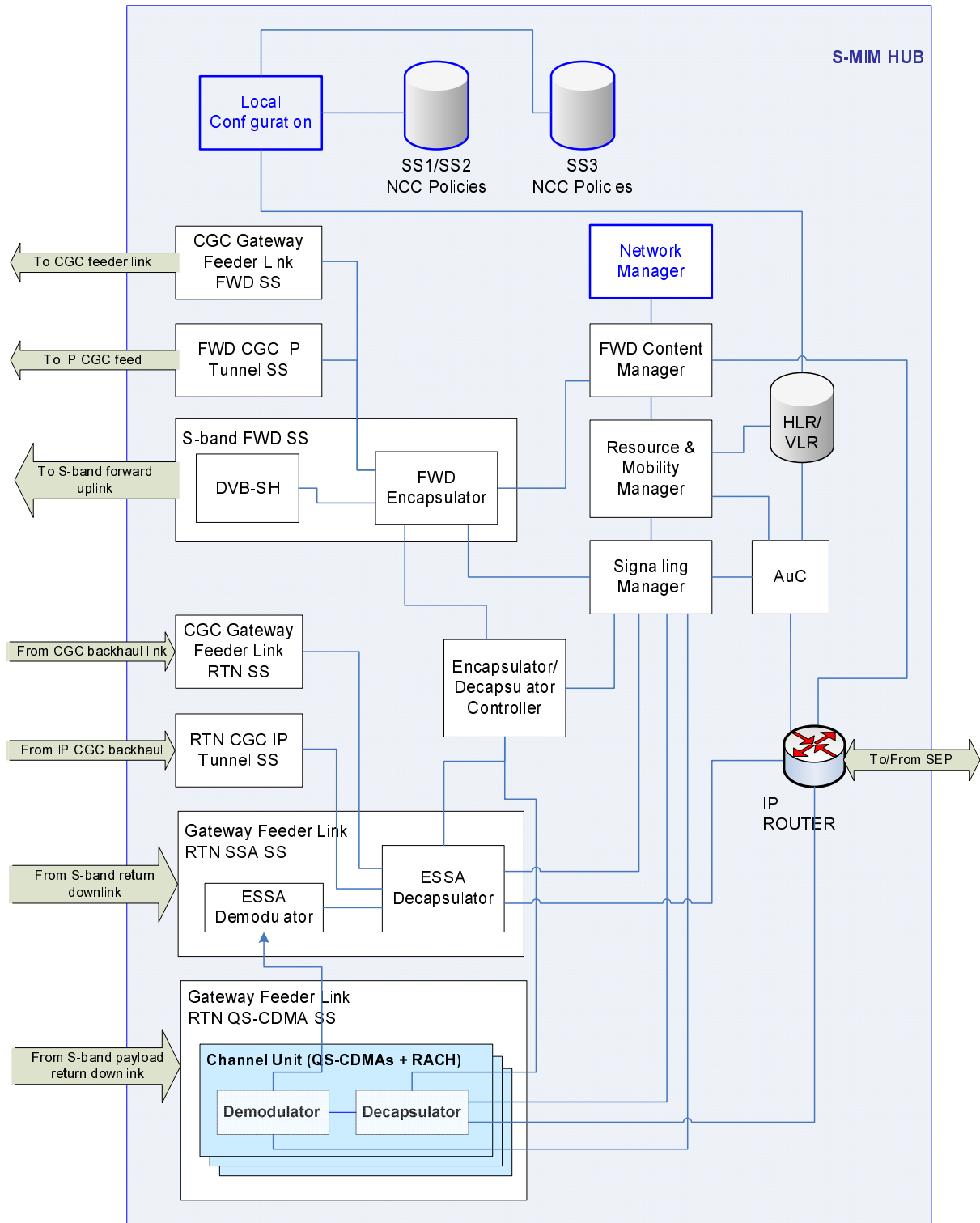

Figure 6.5: Functional diagram of the satellite hub

Table 6.2: Functional description of the satellite Hub

| User Plane | |
|------------------------------------|---|
| S-band FWD SS | This subsystem implements the radio interface in the S-band FWD link. It implements all functions necessary to encapsulate, apply header compression (optional), encryption (optional), filter content, modulate and transmit data in the S-band FWD link; After encapsulating, the S-band FWD SS shall differentiate the content (multiplex) that has to be sent through the satellite from the content (multiplex) that has to be sent through the CGCs; in particular, the CGC multiplex is a repetition of part of the satellite multiplex; additionally, the CGC multiplex may contain local contents not transmitted over the satellite. Figure 6.5 shows the particular case that DVB-SH is the radio interface applied in S-band Subsystem. |
| Gateway Feeder Link RTN SSA SS | The SSA radio interface is used for asynchronous access in the S-band RTN link. It implements all functions necessary to demodulate, decapsulate data; note that the decapsulator may include decryption and header decompression capabilities. Advanced signal processing allowing efficient IC in packet mode (such as SSA) is strongly recommended to increase system throughput particularly in the presence of power imbalance. The deployment of this subsystem is only required in the hub if the hub manages one or several service areas where the deployed services require asynchronous access in the RTN link. |
| Gateway Feeder Link RTN QS-CDMA SS | The QS-CDMA radio interface is used for synchronous access in the S-band RTN link. It implements all functions necessary to demodulate and decapsulate data; note that the decapsulator may include decryption and header decompression capabilities. It also provides the functions necessary to monitor terminal synchronization and power imbalances and compute the appropriate corrections to be forwarded to the terminal. The deployment of this subsystem is only required in the hub if the hub manages one or several service areas where the deployed services require synchronous access in the RTN link to support real-time bidirectional services. |
| CGC gateway feeder link FWD SS | This subsystem acts as the baseline feeder link for the FWD CGCs. It receives a prepared transport stream from the FWD Encapsulator (managed by the content manager) which it re-encapsulates into the Ku-band FWD SS radio interface (see notes 1 and 2). |
| CGC gateway feeder link RTN SS | This subsystem acts as the baseline backhauling facility for the RTN CGCs. It demodulates and decapsulates (and decrypts) the received signal through the RTN link Ku-band radio interface and delivers SSA frames to the SSA Decapsulator (see note 3). |
| FWD CGC IP Tunnel SS | This subsystem acts as the alternative feeder link for the FWD CGCs. It receives a prepared transport stream from the FWD Link Layer SS (managed by the content manager) which it encapsulates into a secure IP tunnel and transmits it through an IP connection towards the CGCs. |
| RTN CGC IP Tunnel SS | This subsystem acts as the alternative backhauling facility for the RTN CGCs. It decapsulates the secure IP tunnel established with the RTN CGCs and delivers SSA frames to the SSA Decapsulator. |
| IP router | It routes the input IP packets (coming from the SSA and the QS-CDMA Decapsulators) towards the relevant Service Enabling Platform, Bidirectional Service Gateway or Broadcast Content Provider. |

| Control Plane | |
|-------------------------------|---|
| Signalling Manager | <p>This functional block manages the system specific signalling. In particular, the following functions are implemented by the signalling manager:</p> <ul style="list-style-type: none"> • Negotiation of security standard to be used in the FWD link (in satellite AND CGC access) for communication with a user terminal; informing the Encapsulator at the S-band SS about the layer at which encryption shall be performed for a specific flow in each link; manage signalling for IPsec security associations in the FWD link. • Management of acknowledgements for the satellite link. • Management of acknowledgements for the CGC links. • Collection of signalling from other functions of the control plane and forwarding of signalling coming from the RTN link to the right control plane function. • Assembly of signalling tables for the satellite link and for the terrestrial links and forwarding to the signalling buffers towards the FWD Encapsulator. • To collect and store information from the S-band RTN SSA SS and the S-band RTN QS-CDMA SS about network activity monitoring (network access level CDRs). In particular, for the S-band RTN SSA SS, at least the following records shall be kept for each received packet: origin, destination, volume of data, time stamp. For the S-band RTN QS-CDMA SS, the CAC/DAMA can collect channel setup and clear time-stamps, RTN link spot ID, clear reason or allocated BW. |
| Resource and Mobility Manager | <p>This functional block has two main sub-functions: the Resource Management and the Mobility Management sub-functions.</p> <ul style="list-style-type: none"> • Resource management sub-function. This sub-function manages the resource allocation in FWD and RTN links. It is composed of the following modules and functionalities: FWD SS1/SS2 Module: composed by the FWD Link Capacity Manager and the NCC policies applicable to SS1/SS2. The FWD Link Capacity Manager manages the data flows for efficient sharing of FWD link resources among flows, for the satellite and for the CGC links. It fulfils the following tasks: <ul style="list-style-type: none"> – Negotiate and stores the QoS guarantees of each flow with the interface of the Service Providers to the Hub. – Monitor the QoS performance of each flow. – Instruct the multiplexer in the Encapsulator about the structure of the output transport stream: <ul style="list-style-type: none"> - to be transmitted over the satellite; - to be transmitted over the CGCs. – packet scheduling, profile selection (RT vs. NRT), capacity share (between RT and NRT profiles) resizing and multiplexing. • RTN SS1/SS2 Module: composed by the RTN load control manager: <ul style="list-style-type: none"> – The RTN load control manager: <ul style="list-style-type: none"> - monitors (i) the load in the satellite RTN link radio interfaces and (ii) the load in the CGC RTN link radio interfaces; - performs load control (i) in the satellite link and (ii) in the CGC links, independently. This functionality is only required at the hub if the services deployed in the managed service area require asynchronous access in the RTN link. • SS3 Module: composed by the CAC/DAMA manager: <ul style="list-style-type: none"> – The CAC/DAMA Manager: it monitors the load in the RTN link synchronous radio interface in the satellite link and performs capacity request/assignment management. This functionality is only required at the hub if the services deployed in the managed service area require synchronous access in the RTN link to support bidirectional real-time applications. <p>Mobility Management sub-function: this sub-function includes functionalities to provide services to the users of the S-MIM system in all service areas. Consequently, the following functionalities are enclosed:</p> <ul style="list-style-type: none"> • Terminal location management; • Handover management; • Roaming management. |
| Content Manager | <p>(see note 4)</p> <p>This function manages the content in the satellite and terrestrial FWD link multiplexes. In particular, the following functionalities shall be implemented:</p> <ul style="list-style-type: none"> • Prepare the multiplex to be feed to the satellite S-band payload and to the CGCs with global and local content through the relevant feeder link and align the global content with the satellite global content. |

| Control Plane | |
|--|--|
| Encapsulator/Decapsulator Controller | <p>This element implements control functions for the Link Layer protocols implemented in the encapsulator/decapsulator:</p> <ul style="list-style-type: none"> • Management of header compression context and forwarding of related signal to the signalling management for the FWD link. • Management of header compression context and forwarding of related signal to the signalling management for the asynchronous RTN link. • Negotiation of bidirectional header compression for synchronous RTN link and related traffic in the FWD link. • Mutual authentication according to Link Layer Security option. • Mutual authentication according to IPsec option. |
| HLR/VLR | <p>These are databases containing user location and profile information.</p> <p>The HLR is a database that contains details of each S-MIM subscriber that is authorized to access the S-MIM system.</p> <p>The HLRs store details of every USIM issued by the S-MIM operator:</p> <ul style="list-style-type: none"> • The IMSI (unique identifier of the subscriber, which is the primary key to each HLR record). • S-MIM services that the subscriber has requested or been authorized to use with its contract. • Current location of subscriber (i.e. visited VLR and serving hub in case of roaming). <p>Its main functions are:</p> <ul style="list-style-type: none"> • To support the mobility management function by updating the current location area applicable to the subscriber. • To send the subscriber data to the VLR of a visited hub when a subscriber first roams there. • To remove subscriber data from the previous VLR when a subscriber has roamed away from it. • The VLR is a temporary database of the subscribers who have roamed into the particular service area which it serves. The enclosed information is acquired either from the home HLR of the subscriber. The stored data is the following: the IMSI, the phone number, the authentication data, the list of services the subscriber is authorized to access, the home hub and HLR of the subscriber. |
| Authentication Centre (AuC) | <p>The AuC is a function to generate authentication vectors that are used during the procedures to authenticate each subscriber that attempts to access the S-MIM system. It also stores shared secret data between the USIM and the AuC to verify identities and to generate encryption keys once a security association is achieved among the subscriber and hub.</p> |
| Management Plane | |
| The Network Manager | <p>This function includes the following sub-functions:</p> <ul style="list-style-type: none"> • Terminal management. • Network management. • User traffic monitoring. |
| <p>NOTE 1: The radio interface implemented by the Ku (or other) -band FWD link SS is out of scope of S-MIM.</p> <p>NOTE 2: In the case that the Ku-band and S-band SS's have independent PID assignment to services and programmes, the Ku-band FWD SS shall include an MPEG-TS encapsulator, as the S-band services shall be then re-encapsulated in MPEG-TS with the PID association related to the Ku-band SS.</p> <p>NOTE 3: The radio interface implemented by the Ku-band RTN link SS is out of scope of S-MIM. However, DVB-RCS is assumed as baseline radio interface.</p> <p>NOTE 4: This module is implementation dependent and will not be specified within the S-MIM system.</p> | |

6.2.2 The Network Control Centre

The NCC manages configurations and policies of the S-MIM network as well as the satellite management (the satellite management aspects are out of scope of the S-MIM system). However, the NCC may also manage the local configuration of each hub and determine decision policies that shall be common (or not) to all hubs.

In particular, the additional NCC functionalities, excluding the satellite management issues, consist of:

- the capability of remotely configure other hubs parameters (e.g. decision policies, thresholds, managing addressing spaces, etc.) through network management protocols;
- keeping overall network list of subscribers and configurations (HLR/VLR), numbering resources;
- overall network usage and performance monitoring;

- provide a common interface for sending SIP signalling from the ground segment. Although, this interface may be implemented in a master hub, see Figure 6.4.

The satellite operator may map each of the Management Plane functions in a distributed (throughout the hubs) or centralized manner (into the NCC) according to its preferences.

6.3 The Complementary Ground Components

FWD CGCs (Repeaters) and RTN CGCs (Collectors) are interrelated; repeaters are stand-alone ground elements managed by the hub, while collectors shall be co-located with repeaters to allow the broadcast of relevant signalling in the FWD link required by the terminal to configure correctly the transmission parameters to be used in the RTN link.

Specific features of repeaters and collectors are detailed in the following clauses.

6.3.1 The FWD CGC

A number of FWD CGCs provide coverage to a common geographical area where the same set of local content is provided, shall operate in SFN among Repeaters. A Set of CGCs operating in SFN, that provide service to a common geographical area, will be called CGC Cluster.

The FWD CGC offers up to four different external interfaces, some of them being exclusive in a CGC cluster (in other words, in a CGC cluster, all CGCs shall support the same FWD air interface):

- $\{IU_1\}$ or $\{IU_2\}$ towards the user terminals; and
- $\{IS_5\}$ (Ku-band or other satellite feeder link frequencies) and/or $\{I_6\}$ (an IP connection) to receive the content that has to be repeated towards the user terminals through the $\{IU_1\}$ or $\{IU_2\}$ interface.

In the case that DVB-SH is applied as $\{IU_1\}$ or $\{IU_2\}$, respectively, the following applies:

Figure 6.6 shows the functional diagram of the Repeater. The functionalities to be fulfilled by each functional block are listed in Table 6.3, classified in User, Control and Management planes. Note that the Control and Management planes refer to the S-band SS only.

Table 6.3: Functional description of the FWD CGC

| User Plane | |
|--|--|
| S-band CGC Tx SS | The following functions are fulfilled by this functional block: <ul style="list-style-type: none"> • To demultiplex the received transport streams to differentiate contents. In particular, signalling to the CGC, global content and different local contents relevant to different CGC Clusters shall be differentiated. • To decapsulate signalling information for remote management of the FWD CGC (network management). • To remove content not meant for the CGC cluster this CGC belongs to. • To feed the relevant content (RT if available and NRT content) to the modulator. • To perform modulation according to {IU1} or {IU2} interface (depending on the deployed technology). • Transmit the signal from the CGC at S-band. |
| Gateway to CGC forward feeder link SS | The Gateway to CGC forward feeder link SS is the baseline feeder link to the FWD CGCs (see note 1). The signal received at the Gateway to CGC forward feeder link SS transports the pre-configured global and local multiplexes. The Gateway to CGC forward feeder link SS shall receive the Ku-band signal and demodulate it (see note 2). The outputs of the Gateway to CGC forward feeder link SS are the pre-configured global and local multiplexes in MPEG-TS format. |
| IP CGC feed SS | The IP CGC feed SS is the alternative feeder link to the FWD CGCs. The physical input interface can be wired or wireless. The IP SS manages an (secure) IP tunnel between the Repeater and the serving hub. It has as input an IP stream that transports the pre-configured global and local multiplexes in MPEG-TS format. The IP SS shall receive the input IP signal and decapsulate (undo the IP tunnel) it to output one or several MPEG-TS streams. |
| Control Plane | |
| N/A | All Control Plane functions related to the CGC are fulfilled in its managing hub. The CGC simply repeats the signal received through its feeder link and removes useless content in the corresponding SFN area. |
| Management Plane | |
| S-band SS | Within the S-band SS, the following control plane functions shall be included: Network Management: this function receives remote management commands from its managing hub or NCC to allow remote configuration and control of sub-systems |
| NOTE 1: The Gateway to CGC forward feeder link SS specification is out of scope of the S-MIM system. NOTE 2: In the case that the Gateway to CGC forward feeder link SS and the S-band SS have independent PID assignment to services and programmes, the Ku-bands SS shall include an MPEG-TS decapsulator, as the S-band services shall be then re-encapsulated in MPEG-TS with the PID association related to the Gateway to CGC forward feeder link SS. | |

6.3.2 The RTN CGC

The RTN CGC shall be co-located with a Repeater to allow the broadcast of local signalling of the Collector. Figure 6.7 shows the functional diagram of the Collector completing the functional block of the Repeater to allow also access in to RTN link services.

Additionally to the FWD link-related interfaces, the Collector presents additional external interfaces:

- {IU3} (SSA) from the user terminals; and
- {IS₅} (Ku-band - or other - RTN satellite link) and/or {I₆} (an IP connection) for backhauling of received data from the user terminals towards the hub.

Figure 6.7 shows the functional diagram of the Collector, including those of the co-located Repeater. The functionalities to be fulfilled by each functional block are listed in Table 6.4 classified in User, Control and Management planes.

Table 6.4: Functional description of the RTN CGC

| User Plane | |
|--|---|
| S-band CGC Rx SS | <p>Additionally to the Repeater-specific functional blocks, the following functionalities shall be fulfilled by the Collector S-band RTN SS:</p> <ul style="list-style-type: none"> • Receive and demodulate the SSA input signal. • Feed the output SSA frames into the CGC to GW return feeder link SS encapsulator (or into the IP network SS encapsulator). |
| CGC to GW return feeder link SS | <p>The CGC to GW return feeder link SS is the baseline backhauling link to the RTN CGCs (see note 1). Additionally to the Repeater-specific functionalities, the following functions shall be fulfilled by the CGC to GW return feeder link SS:</p> <ul style="list-style-type: none"> • Encapsulate the input SSA frames in the data format of the CGC to GW return feeder link SS. • To monitor the input buffer and generate capacity requests to cope with the input traffic (see note 2). • To interpret and apply the capacity allocations signalled by the managing hub of the CGC through the satellite feeder link (and demodulated at the feeder FWD SS). • To modulate the backhauling signal. • To transmit the backhauling signal (for example in Ku-band). |
| IP CGC feed SS | <p>The IP CGC feed SS is the alternative backhauling link in the RTN CGCs. The physical output interface can be wired or wireless. Additionally to the Repeater-specific functionalities, the following functions shall be fulfilled by the IP CGC feed SS in the RTN link:</p> <ul style="list-style-type: none"> • to create and maintain an (secure) IP tunnel between the RTN CGC and the serving hub to backhaul the received SSA frames through the S-band RTN SS. |
| Control Plane | |
| N/A | <p>All Control Plane functions related to the CGC are fulfilled in its managing hub. The CGC simply repeats the signal received through its feeder link and removes useless content in the corresponding SFN area.</p> |
| Management Plane | |
| S-band SS | <p>Network Management: this function receives remote management commands from its managing hub or NCC to allow remote configuration and control of sub-systems.</p> |
| <p>NOTE 1: The CGC to GW return feeder link SS specification is out of scope of the S-MIM system.</p> <p>NOTE 2: This is assuming that the backhauling link is a shared link with other CGC to GW feeder RTN SS or other services. In the case that a fully dedicated link (SCPC) is allocated to the CGC, the management of capacity requests is not required, and in any case out of scope of S-MIM.</p> | |

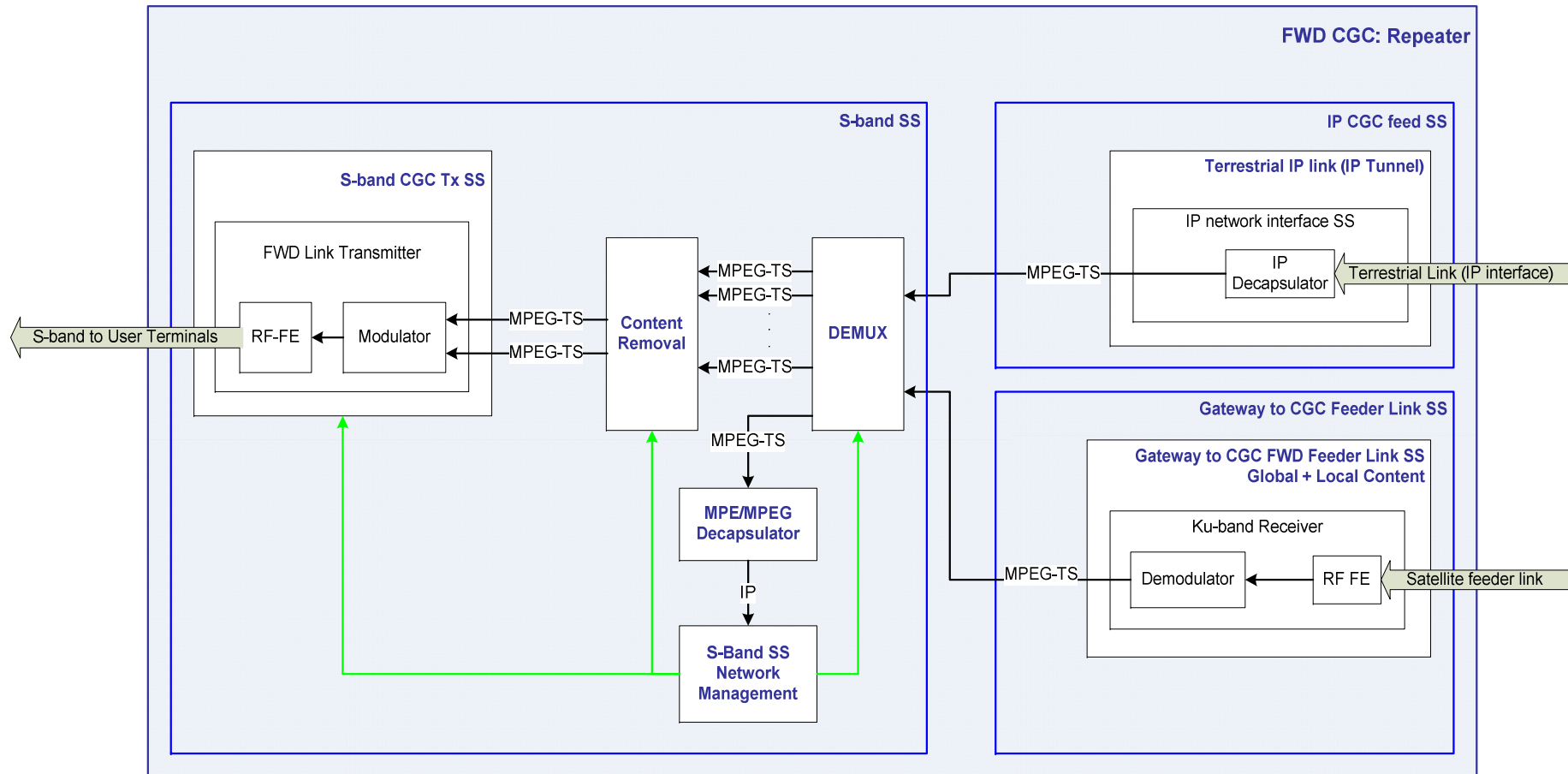

Figure 6.6: Functional diagram of the FWD CGC

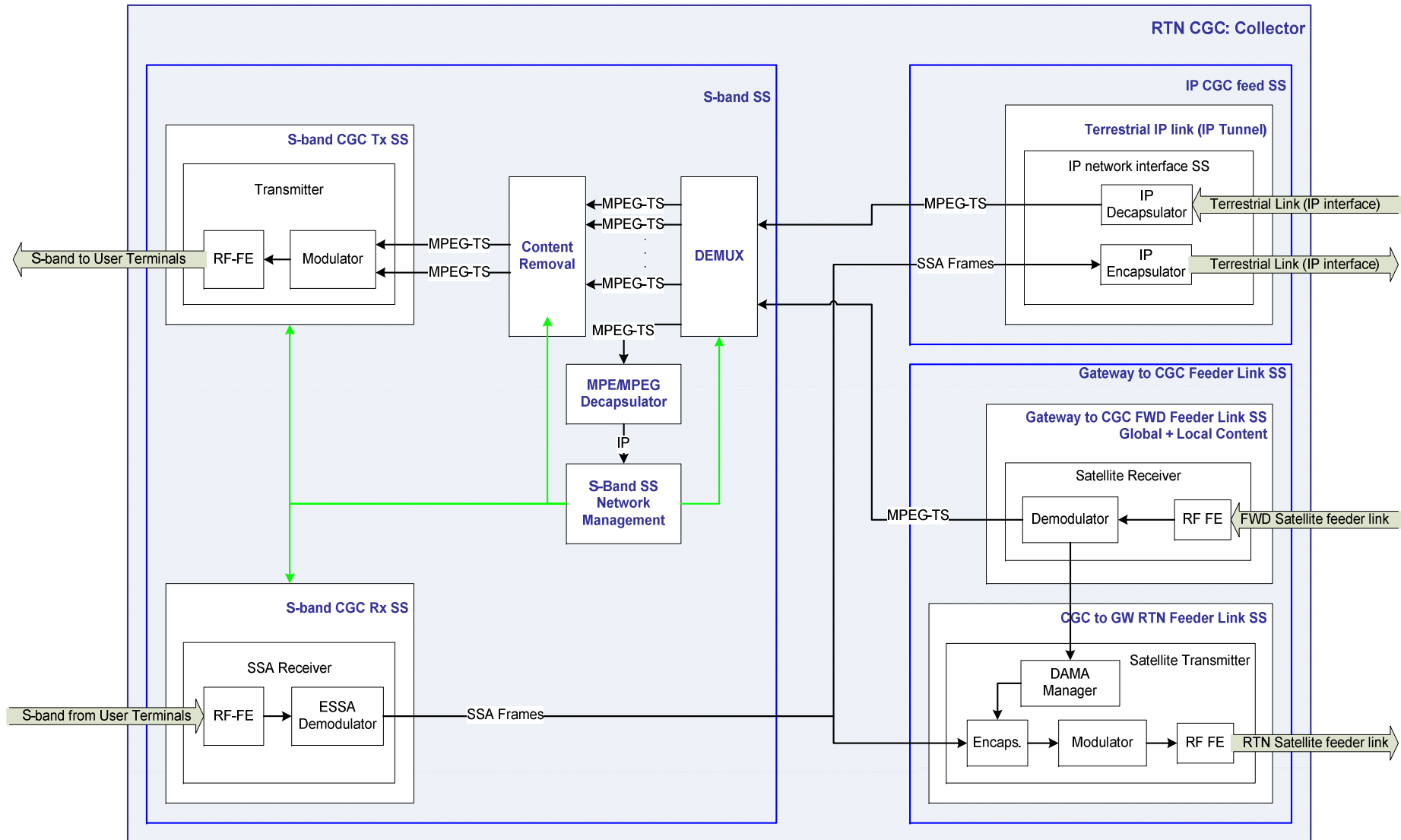

Figure 6.7: Functional diagram of the RTN CGC

7 Protocol Architecture

Network element functions are divided into three planes: User, Control and Management.

The following clauses show protocol stacks for combined User and Control planes in the FWD and RTN links. The Management Plane is described in Annex D.

Further details are given in the other parts of this multi-parts deliverable.

7.1 Forward Link

7.1.1 Forward Link Reference Protocol Stack

The generalized protocol stack for the Forward link for access to SS1, SS2 and SS3 is depicted in Figure 7.1.

For SS1/2, the upper layer protocols (referred to as Application & Service Delivery Layer in the figure) correspond to the IP Datacast protocols plus an additional delivery protocol to deliver short messages, the S-MIM Messaging Protocol (SMP). The SMP has been introduced to optimally deliver short messages over the underlying PHY, as the IP Datacast protocols are optimized for the transmission of streaming and data in the form of medium to long files.

The use of a connectionless Transport Protocol, such as UDP, is strongly recommended to communicate with SS1 and SS2 user terminals, as all services under such service segments are connectionless as well.

For SS3 an UDP/IP layer is also considered to provide support to standard VoIP protocols, SIP, RTP and RTCP. Additionally, a TCP/IP layer is required to provide support to HTTP, FTP or other protocols that rely on the provision of 2-way IP connectivity services in the scope of SS3.

The Link Layer provides efficient transport of IP user data over the forward link radio interface.

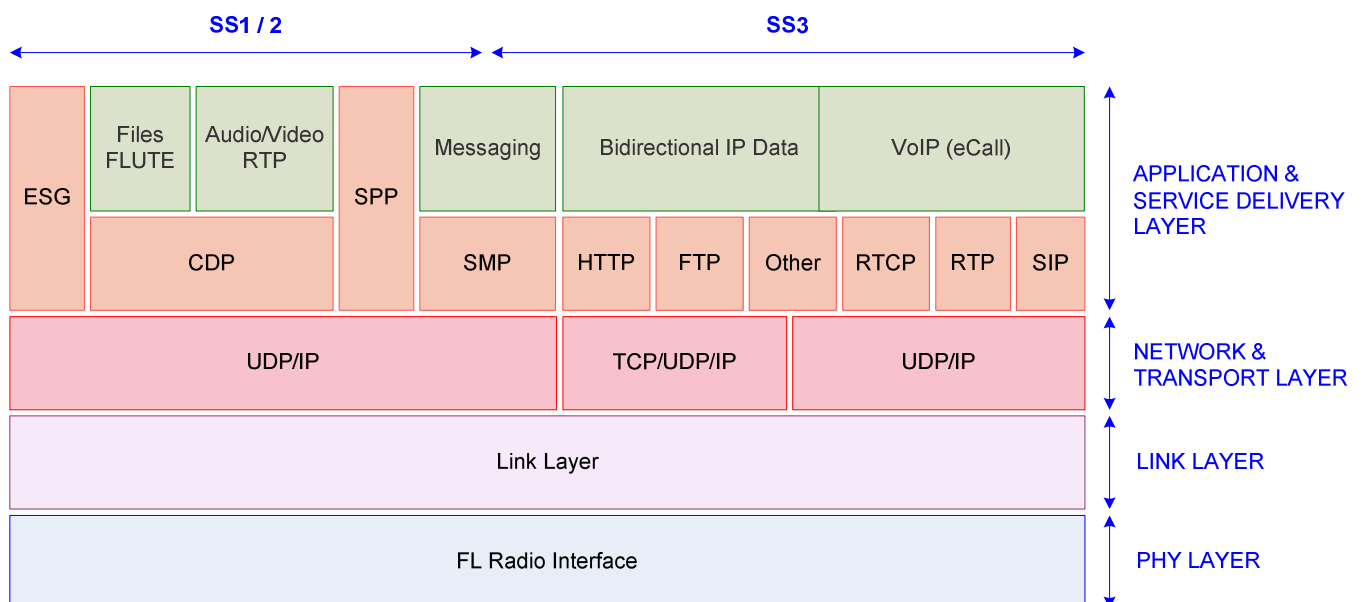

Figure 7.1: Generalized protocol stack for the Forward link

7.1.2 Forward Link Protocol Architectures

Two cases of protocol stack are defined for transport of user data between the Hub and the user terminal:

- 1) satellite link only;
- 2) satellite and/or the FWD CGC.

The blocks marked in yellow are those specific to the S-MIM system.

7.1.2.1 Satellite Link Only

Figure 7.2 shows the case in which only the satellite is used.

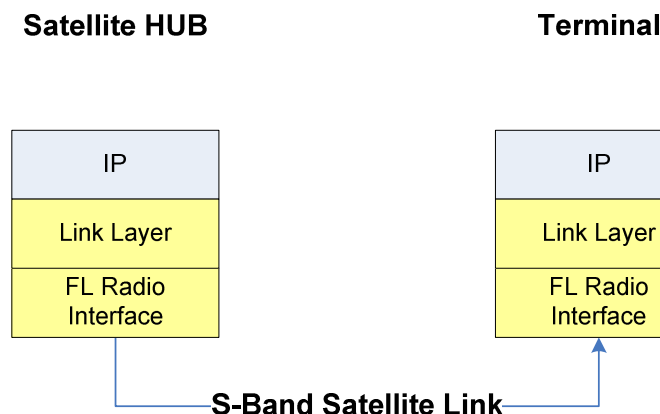

Figure 7.2: Forward Link Protocol Architecture for Satellite Connectivity

7.1.2.2 Satellite and/or FWD CGC

Figure 7.3 shows the end-to-end protocol architecture. Depending on the feeder link selected for the repeater, the satellite Hub will need specific interfaces. Two examples are shown in Figure 7.3: (i) the feeder link is a Ku-band air interface (e.g. DVB-S2) and (ii) the feeder link is an IP connection.

In the first case, the link layer at the Hub delivers MPEG transport streams to the Ku-band air interface, which transports them transparently.

NOTE 1: To allow this transparent transport, the PID services of the S-band system should be known to the Ku-band system. If this is not fulfilled, the MPEG-TS from the S-band mission should be re-encapsulated into dedicated MPEG-TS of the Ku-band mission.

The FWD CGC (or repeater) receives the Ku-band waveform, demodulates it and recovers the transported MPEG-TS over the Ku-band waveform. Then, the CGC disaggregates the transport stream in its primary streams and removes the primary streams that do not correspond to services for the CGC (local content of other SFN clusters) and inserts the filtered multiplex into the FWD radio interface modulator of the CGC.

NOTE 2: The CGC should be capable of differentiating which services it should transmit from those that are not meant for this CGC.

In the second case, an IP tunnel is assumed for feeding the repeaters with content. Therefore, the output data of the link layer is re-encapsulated into an IP tunnel in a transparent manner. Consequently, the Repeater shall implement also the IP tunnel features in order to recover the MPEG-TS stream provided by the link Layer and feed it to the FWD radio interface modulator.

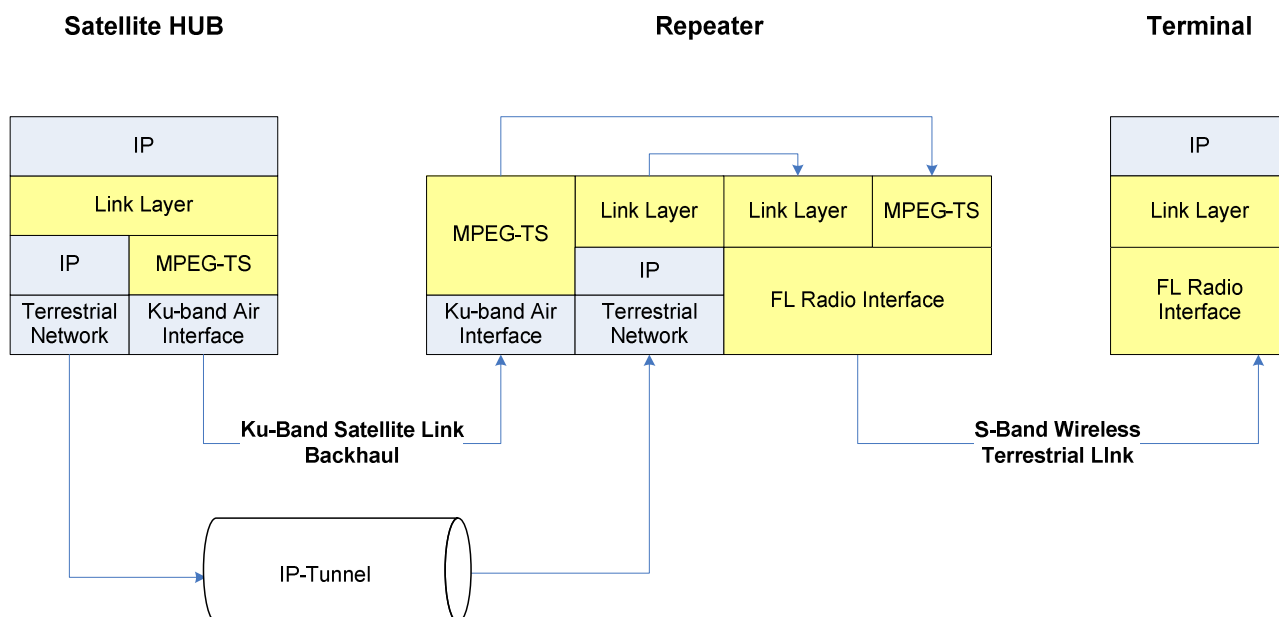

Figure 7.3: Forward Link Protocol Architecture for Terrestrial Connectivity

7.2 Return Link

The SSA and QS-CDMA options are described separately below.

In the baseline configuration, S-MIM synchronous and asynchronous access schemes share the whole bandwidth. Alternatively, a 5 MHz RF channel might be split in narrower RF channels that could be dynamically assigned to the S-MIM synchronous or asynchronous accesses. In this case, narrower channelization would be used.

7.2.1 Asynchronous Return Link Reference Protocol Stack

As per the Forward link protocols, the Internet Protocol (IP) shall be supported in the Return link. Only short messages shall be transmitted through the SSA access. Therefore the same protocol as in the FWD link to deliver short messages will be applied in the upper layer, as can be observed in Figure 7.4.

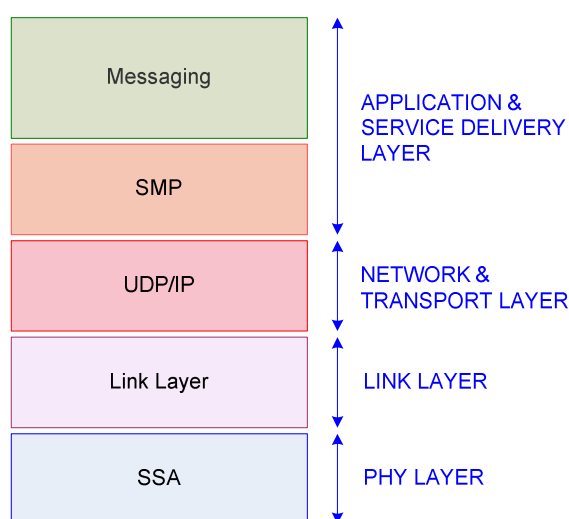

Figure 7.4: General protocol stack for Asynchronous (SS1/SS2) return link

7.2.2 Asynchronous Return Link Protocol Architectures

Two cases of protocol stack are defined for transport of user data between the Hub and the user terminal:

- 1) satellite link only;
- 2) satellite and/or the RTN CGC.

The blocks marked in yellow are those specific of the S-MIM system.

7.2.2.1 Satellite Link Only

Figure 7.5 shows the case in which only the satellite is used.

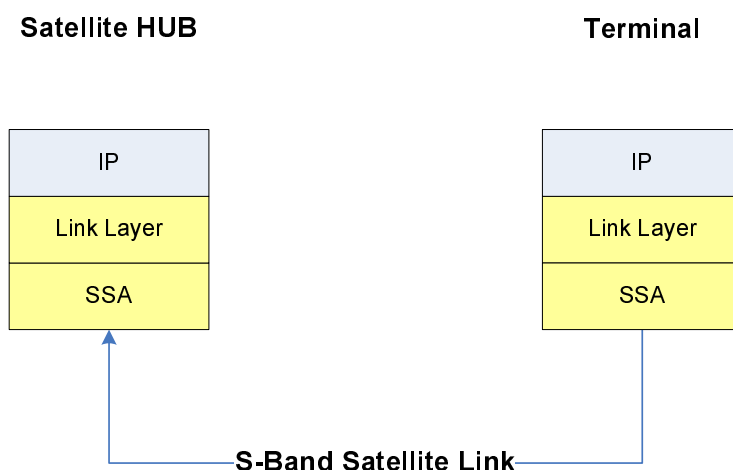

Figure 7.5: Asynchronous Return Link Protocol Architecture for Satellite Connectivity

7.2.2.2 Satellite and/or RTN CGC

For communications through the RTN CGC, Figure 7.6 shows the S-MIM protocol stack. In this case, the presence of a RTN CGC (or Collector) adds some complexity to the protocol stack at the Hub. As it can be observed, depending on the backhauling link selected for the Collector, the satellite Hub will need specific interfaces. Two examples are depicted in Figure 7.6, namely the cases that the backhauling link is a Ku-band air interface (e.g. DVB-RCS) or an IP connection.

In the first case, the link layer at the Hub delivers SSA frames to the Ku-band air interface, which transports them transparently. The Collector just feeds the received SSA frames into the Ku-band Subsystem that encapsulates the SSA frames transparently into the data format of the Ku-band radio interface. In the second case, an IP tunnel is assumed for backhauling the data received at the Collectors. Therefore, the output data of the SSA demodulator (SSA frames) is re-encapsulated into an IP tunnel in a transparent manner. Consequently, the Hub shall implement also the IP tunnel features in order to recover the SSA frames and feed them into the link layer at the Hub.

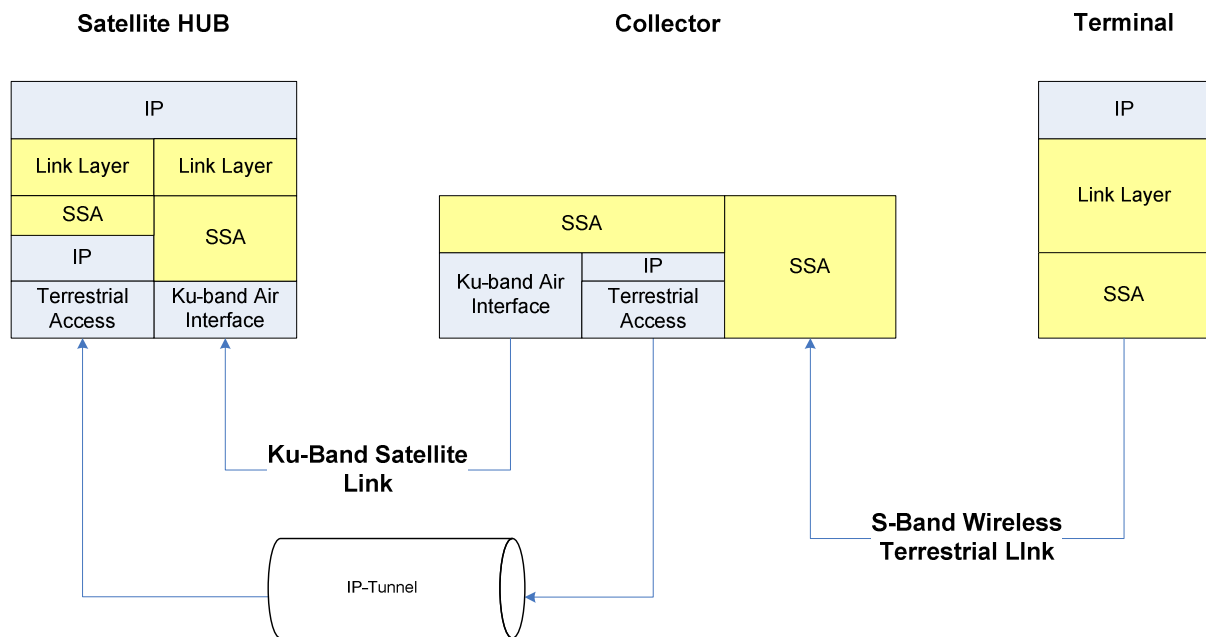

Figure 7.6: Asynchronous Return Link Protocol Architecture for Terrestrial Connectivity

7.2.3 Synchronous Return Link Reference Protocol Stack

The Internet Protocol (IP) shall be supported in the QS-CDMA RTN link. Through the QS-CDMA access, the following services are provided: eCall, VoIP and two-way-IP connectivity. Inline with these requirements, the reference protocol stack for the QS-CDMA RTN link in the User Plane for access to SS3 is depicted in Figure 7.7.

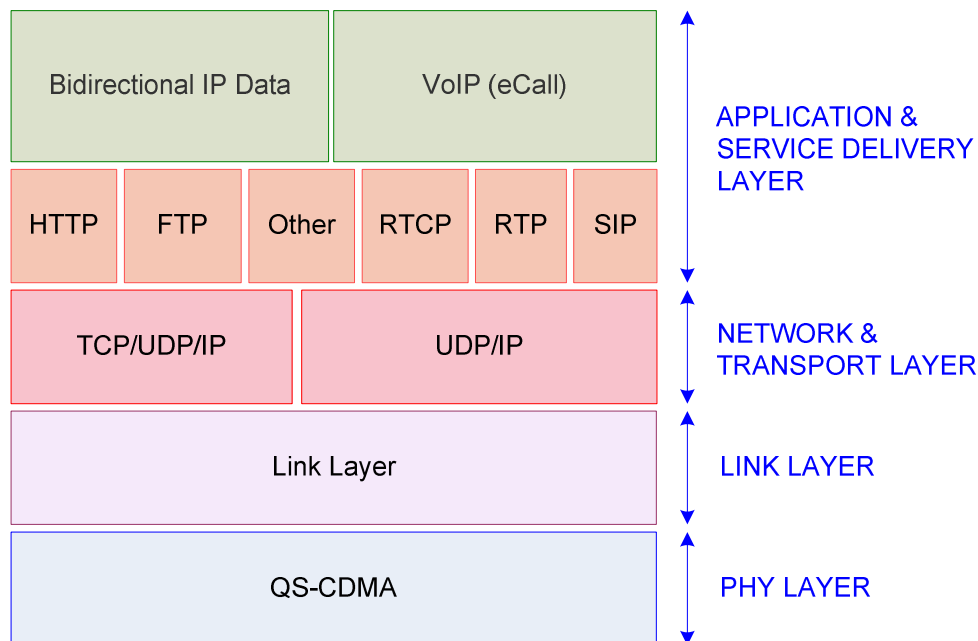

Figure 7.7: General protocol stack for Synchronous (SS3) return link

7.2.4 Synchronous Return Link Protocol Architecture

Unlike the asynchronous access, the synchronous access is only applicable to the satellite link. Services corresponding to SS3 are not distributed over the CGCs. Figure 7.8 shows the protocol stack for the S-MIM access in the synchronous return link access.

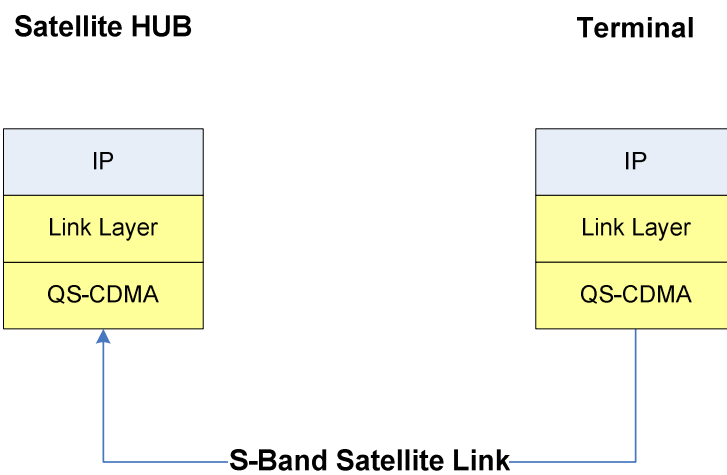

Figure 7.8: Synchronous Return Link Protocol Architecture for Satellite Connectivity

Annex A (normative): Mapping of Services into Forward Link Physical Layer Channels

Table A.1

| Service Segment 1 - Broadcast and Interactive Services | | NRT Profile | RT Profile |
|---|--|--------------------------------|------------|
| | | (M = mandatory, P = preferred) | |
| One-way broadcast/multicast services | Streaming | M | - |
| | Data distribution | M | - |
| Interactive broadcast/multicast services | Interactive streaming | PayPerView | - |
| | | Televoting | P |
| | | Home-shopping | P |
| | Interactive data distribution | PayPerUse | P |
| Content repair | | P | |
| Service Segment 2 - Data Acquisition Services | | | |
| Messaging services | Vehicle telemetric | - | P |
| | Environmental Monitoring | - | P |
| Messaging Services in Combination with GNSS Applications | Anti-theft Services | - | P |
| | Traffic Monitoring | - | P |
| | Automatic Toll Payment | - | P |
| | Distress Beacon | - | P |
| | Interactive Distress Beacon | - | P |
| SMS | - | - | P |
| Service Segment 3 - Real-Time (Emergency) Services | | | |
| Public safety and emergency services | eCall | - | M |
| | Two-way IP connection | - | M |
| | Broadcast of Common Interest Messages | - | P |
| Broadband for Professional and Consumer Use | - | - | M |
| Signalling | | | |
| Resource Management | Load control | - | M |
| | Call Admission Control | - | M |
| | DAMA Assignment | - | M |
| Operational Signalling | Local configuration | - | P |
| | ACKs | - | P |
| | AAA/Encryption | - | P |
| | Capacity share resizing (NRT vs. RT) | - | P |
| Mobility Management | Authentication messages and system information (PSI/SI) are used. Each will use one profile. | M | M |
| Service Management | Announcement, association tables, etc. | M | - |
| Terminal Management | | P | - |

Annex B (informative): Network Architecture Configurations

The modular S-MIM network architecture described in clause 5 can be implemented in different configurations (and sub-configurations), based on a core set of elements, to suit provision of different Service Segments.

The complete network architecture including all optional elements and interfaces is shown in Figure B.1. This also shows the Core S-MIM Network components necessary for any configuration.

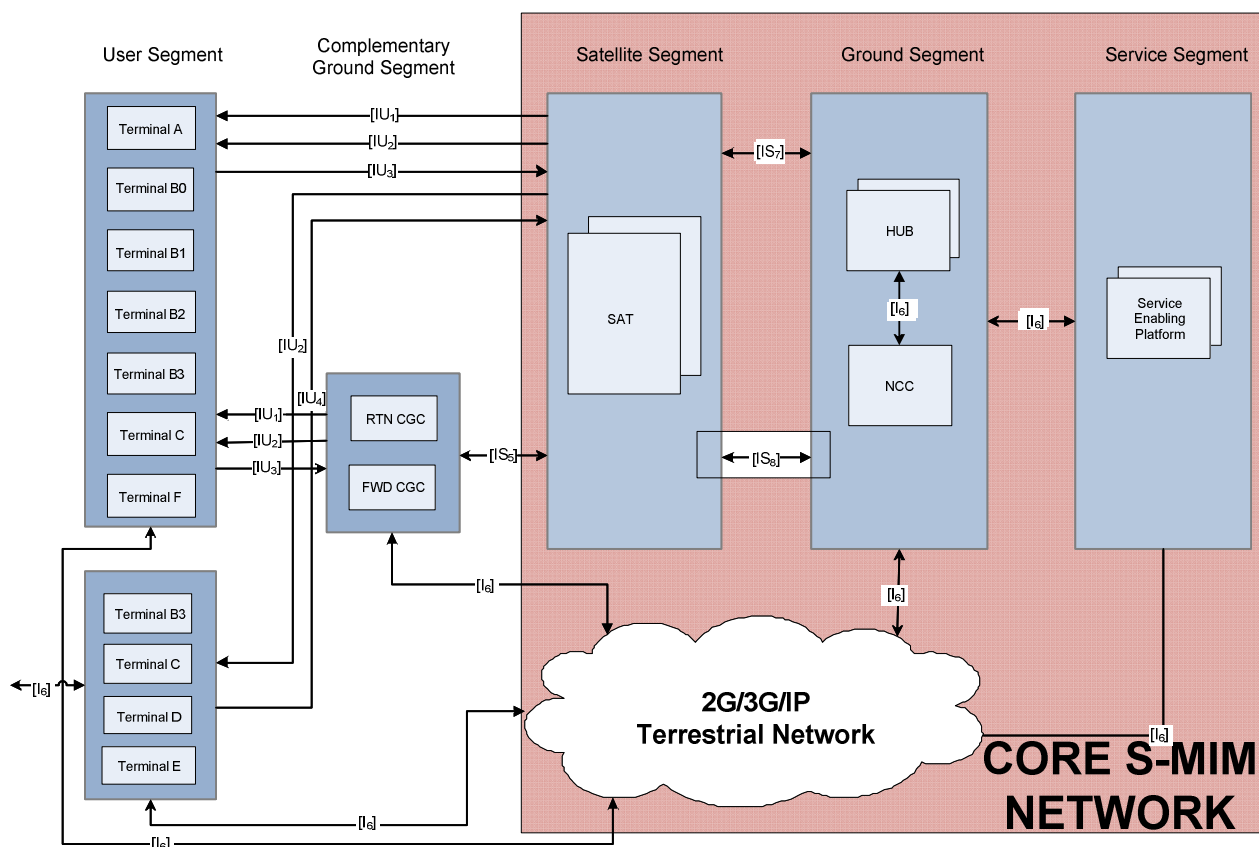

Figure B.1: Complete S-MIM network architecture

Depending on the configuration, some of the elements of the radio access part of the system shown are not required.

The main architecture configurations with necessary elements and interfaces are shown in Table B.1.

Table B.1: S-MIM Network Architecture Configurations

| Config | Service Segments | Sub-configuration | Features | Additional Elements to "Core" | Associated additional interfaces |
|--------|--------------------------------------|-------------------|---|-----------------------------------|----------------------------------|
| 1 | SS1 + SS2 + SS3 | 1a | Full S-MIM Deployment | Terminals A, B0, B1, B2, B3, C, F | IU2, IU3 |
| | | | | Terminals B3, C, D, E, | IU2, IU4 |
| | | | | Forward CGC | IU2, IS5 (or I6) |
| | | | | Return CGC | IU3, IS5 (or I6) |
| | | 1b | Absence of Collector | Terminals A, B0, B1, B2, B3, C, F | IU2, IU3 |
| | | | | Terminal B3, C, D, E | IU2, IU4 |
| | | | | Forward CGC | IU2, IS5 (or I6) |
| | | 1c | Absence of Repeaters | Terminals A, B0, B1, B2, B3, C, F | IU2, IU3 |
| | | | | Terminal B3, C, D, E | IU2, IU4 |
| | | 1d (no SS3) | FWD link without real time capabilities | Terminals A, B0, B1, B2, B3, C, F | IU1, IU3 |
| | | | | Forward CGC | IU1, IS5 (or I6) |
| | | | | Return CGC | IU3, IS5 (or I6) |
| 2 | SS2 Only | 2a | FWD link without real time capabilities | Terminals A, B0, B1, B2, B3, C, F | IU1, IU3 |
| | | | | Forward CGC | IU1, IS5 (or I6) |
| | | | | Return CGC | IU3, IS5 (or I6) |
| | | 2b | FWD link with real time capabilities | Terminals A, B0, B1, B2, B3, C, F | IU2, IU3 |
| | | | | Forward CGC | IU2, IS5 (or I6) |
| | | | | Return CGC | IU3, IS5 (or I6) |
| 3 | SS3 Only | | | Terminals B3, C, D, E, | IU2, IU4 |
| 4 | SS1 (with no interactivity) + SS3 | | | Terminals A, C | IU2 |
| | | | | Terminals C, B3, D, E | IU2, IU4 |
| | | | | Forward CGC | IU2 IS5 (or I6) |

The configurations detailed above apply to services provided by a single satellite payload and its related CGCs.

These configurations allow independent network configurations in different satellite beams.

Annex C (informative): The Service Enabling Platform

The Hub-side Service Enabling Platform (SEP) and its terminal-side counterpart Service Enabling Layer (SEL) middleware interact to provide users with access to any SS supported by the class of terminal employed. This intermediate platform is the transaction gateway of all service segments between the end users and the corresponding Service Providers.

The aim of the S-MIM network is not to impose a particular technology for any particular service segment, but to employ standard protocols such as SIP for VoIP and eCall SS3 services. End users will be aware of an available interface (an IP address and some open ports mapped to each service) prepared to connect them to the contracted Service Providers.

The SEP is broken down into two SSM's (Server Side Middleware), the SSM1/2 interfacing to SS1 and SS2, and SSM3 interfacing to SS3. The same structure is replicated at the SEL side which defines the SSM1/2 and SSM3 counterparts: OBU Side Middleware (OSM1/2 and OSM3).

C.1 Server Side Middleware for SS1 and SS2

The SSM1/2 contain the functions that serve as interfaces between the S-Band Network Platform and:

- the Service Centres; and
- the Alternative Ground Networks (if any);

in order to provide network independence and interoperability with existing service providers. The presence of OBU Side Middleware (OSM1/2) on the User Terminal is foreseen to interact with the Server Side Middleware (SSM1/2).

Table C.1: Functional description of SEP/SSM1/2

| SEP/SSM3 | |
|--|---|
| Service-Level AAA | The SSM1/2 performs the Service Authentication, Authorization and Accounting of both Service Providers and User Terminals. Different levels of service AAA are possible on the User Terminal side. The SSM1/2 can perform the Service AAA of the S-band SS (in case only this interface can be used to consume a type of service) or of the whole User Terminal (i.e. both interfaces, S-band SS and IP SS, can be used). It is evident that the S-band SS can be authenticated and authorized from a service point of view by the SSM1/2 only if this interface has already authenticated and authorized at System level by the Hub. Finally, a User AAA is possible if different User can access a User Terminal. |
| S-MIM Messaging Protocol (SMP) Manager | The SSM1/2 uses high level protocols to perform AAA. For example SOAP (through IP SS) and S-MIM Messaging Protocol (through S-band SS) could be used: <ul style="list-style-type: none"> • Address Conversion: Service Providers address User Terminals and Users using public addresses such as: user ID, International Phone Number, nick name, etc. The SSM1/2 performs addressing conversion in order to deliver the message to the right User Terminal using the IP Address of the available interface of the User Terminal (S-band SS or IP SS) which will be used to deliver (or to receive) messages (Switching Functionality). • Message Protocol Conversion: the SSM1/2 manages the protocol conversion from/to the SOAP Protocol, used to communicate with Service Providers, to/from the S-MIM Messaging Protocol used to deliver or receive messages to/from User Terminals (Session Functionality). |
| QoS Negotiation | QoS Negotiation: the SEP communicates with the SS1 and SS2 Service Providers in order to negotiate, on the behalf of the Hub, the QoS guarantees of each service flow. |
| SMS/MMS Gateway | It contains the SMS/MMS Gateway used to collect/deliver SMS/MMS messages from/to 2G/3G/4G/PSTN Networks. |
| SEP Location Register (SLR) | The SEP collects most of the data required to perform the previous AAA processes directly from the SS1/SS2/SS3 Service Provider (they are the owner of the customer) and from the Hub/NCC which is the responsible of the S-band SS interface. The SLR is a common function for SS1/SS2 and SS3 services. |

C.2 Server Side Middleware for SS3

The Server Side Middleware for SS3 (SSM3) is the subsystem of the SEP which provides SS3 connectivity between S-MIM end users and SS3 Service Providers, which are typically located in terrestrial networks.

The SSM3 at SEP should offer functionalities for the provision of the S3 services:

- 1) *Service-Level AAA*: This functionality is the same as the one explained in clause C.1 except for User AAA, which should be directly authenticated by the Service Provider. The OSM3 elements (class D terminals) and SSM3 could help performing authentication functions for example in VoIP calls based on SIP REGISTER and also collect CDRs information. Regarding Two-way IP connectivity (just class D terminals), User AAA is out of the scope of S-MIM, in order to be as compatible as possible to any user application running in devices connected to the terminal, and no particular mechanism or protocol is imposed for AAA in this service. As an option or recommendation, 802.1x or captive portal approaches could be implemented.
- 2) *VoIP service, including eCall*: SSM3 should include an SIP/RTP proxy that performs call routing for users both in B3/C class terminals and behind D class terminals. Another SIP/RTP proxy should be placed at OSM3 that should authenticate class D terminal's end users locally and route outgoing and incoming voice calls to/from SSM3. Furthermore, no SIP/RTP proxy will be placed on every Hub in order to simplify the overall VoIP architecture, allowing horizontal handover (among Hubs). Instead, high capacity IP links interconnecting all the Hubs and SSM3 are contemplated. IPv4 to IPv6 addressing conversion at both OSM3 and SSM3 is contemplated making use of SIP and RTP proxies; this approach avoids the use of tunnels to convey IPv4 datagrams all across the S-MIM system which have a huge impact in the performance of the header compression mechanism at Link layer level.
- 3) *Generic Two-way-IP connectivity*: This service is exclusive for class D terminals. Both OSM3 and SSM3 should have elements that enable this service. A PEP (Performance Enhanced Proxy) could be placed both at OSM3 and SSM3 as an option. In order to solve the problem of IPv4 to IPv6 addressing conversion, IPv6 tunnelling encapsulation should be performed at OSM3 and SSM3.

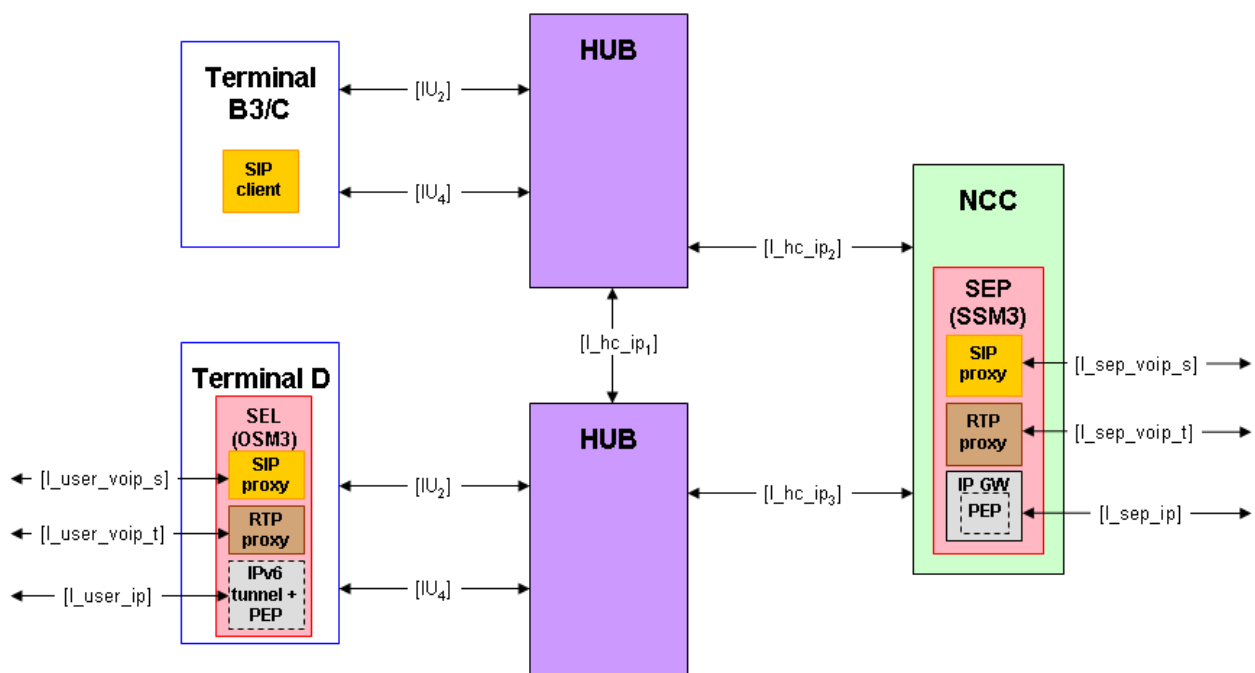

Figure C.1: The SEL/OSM3 and SEP/SSM3 for SS3 architecture and interfaces

Figure C.1 shows the high level architecture and the interfaces involved in the Service Enabling Platform and Service Enable Layer modules for SS3, as described in Table C.2.

Table C.2: Functional description of SEP/SSM3

| SEP/SSM3 | |
|-----------------|--|
| SIP Proxy | SSM3 should include a high capacity SIP proxy that performs call routing functions for all the S-MIM VoIP capable SS3 terminals. It will manage all the SIP signalling going to or coming from the VoIP terminals in S-MIM including eCall service. |
| RTP Proxy | Working in conjunction with the high capacity SIP Proxy, this module implements the required functionalities to handle VoIP voice packets (RTP) for only the VoIP calls (including eCalls) between VoIP capable SS3 terminals and terminals located at external networks (beyond ITSPs). Other features are listed below: <ul style="list-style-type: none"> • Full IPv4 to IPv6 addressing translation for RTP voice packets. That is, the RTP proxy should have two physical interfaces, one with global IPv6 address (facing S-MIM terminals) and one with public IPv4 address (facing Internet Telephony Service Providers). These physical interfaces may coincide with the SIP proxy ones. • Call control and direct interaction with SIP proxy to provide further IPv6 to IPv4 addressing conversion for RTP packets. |
| IP Gateway | This element is exclusive for class D terminals offering Two-way IP connectivity service. Both OSM3 and SSM3 should have elements that enable this service. Regarding the features concerning SSM3 we have the following: <ul style="list-style-type: none"> • A PEP (Performance Enhanced Proxy) could be placed both at OSM3 and SSM3 as an option. • In order to solve the problem of IPv4 to IPv6 addressing conversion, IPv6 tunnelling encapsulation should be performed at OSM3 and SSM3. • Due to the fact that IPv4 addressing at D class terminal LAN will be private, Network Address Translation function between IPv4 private addressing and public IPv4 address pool should be performed at the IP gateway for data Internet access. This is performed once the IPv6 encapsulation is taken out from the original IP packet. • User AAA for Two-way IP connectivity is out of the scope of S-MIM, in order to be as compatible as possible to any user application running in devices connected to the terminal, and no particular mechanism or protocol is imposed for AAA in this service. As an option or recommendation, 802.1x or captive portal approaches could be implemented in OSM3. |

From the point of view of a ground segment ITSP, the S-MIM system should provide a single SIP point of access in case of an incoming voice call from terrestrial networks such as ISDN or PSTN. The calling user dials a prefix number that reaches the SSM3's SIP proxy but once there, the SSM3 knows about the location information (that is IPv6 address) of the called party, which is some end user behind a SS3 capable Terminal. In Figure C.1 this access point, {I_sep_voip_s}, has been located at the NCC where the SEP might be placed. The location of the interface at hand is not important provided that it has access to the database linking a user behind a SS3 terminal to an IPv6 address.

In case that this end user is behind a class D terminal, the calling user should know an additional prefix that identifies this particular class D terminal SIP proxy. That way, VoIP call routing will be much easier for SSM3 SIP proxy. As terminal D usage is contemplated for emergency scenarios, the previous assignation of terminal D prefixes can be affordable and reasonable.

Annex D (informative): Management Plane

Network Management is the responsibility of the network and service provider(s), and is not formally specified for operation of the S-MIM system. Instead, recommendations are indicated below.

A set of minimum network management functions for S-MIM system is defined, which may be complemented with functions provided by service providers.

A common Management Plane architecture is defined for both forward and return links.

An example of requirements for management of terminals and network devices is given in the DVB specification [i.7]. An S-MIM network management system is considered to be included within the Hub/NCC, where it is possible to identify two logical entities:

- The **Remote Management System (RMS)**, which is in charge of the management and modification of the functioning of a device under its control.
- The **Firmware Update System (FUS)** which stores and manages the list of firmware versions available.

Both entities communicate with the network/service providers, devices to be managed, and with device manufacturers. The SOAP protocol over secure HTTP can be used for communicating with the device manufacturers (for provision of firmware updates and management tools), and with service providers. Communications between FUS and the manufacturer can be also performed using FTP or HTTP.

SOAP/Https can also be used for the communication between management entities and network devices because a WAN interconnection is usually available. The CWMP or SNMP protocols on top of this protocol stack any also be used manage the network elements.

For remote management of user terminals the characteristics of the S-Band radio interface require use of management protocols on top of a UDP/IP stack.

The following figure shows the main protocols involved in management. With regard to the remote terminal management, the main operations are carried out via SNMP/UDP/IP, while the delivery of files (such as firmware upgrades) is carried out with the FLUTE protocol.

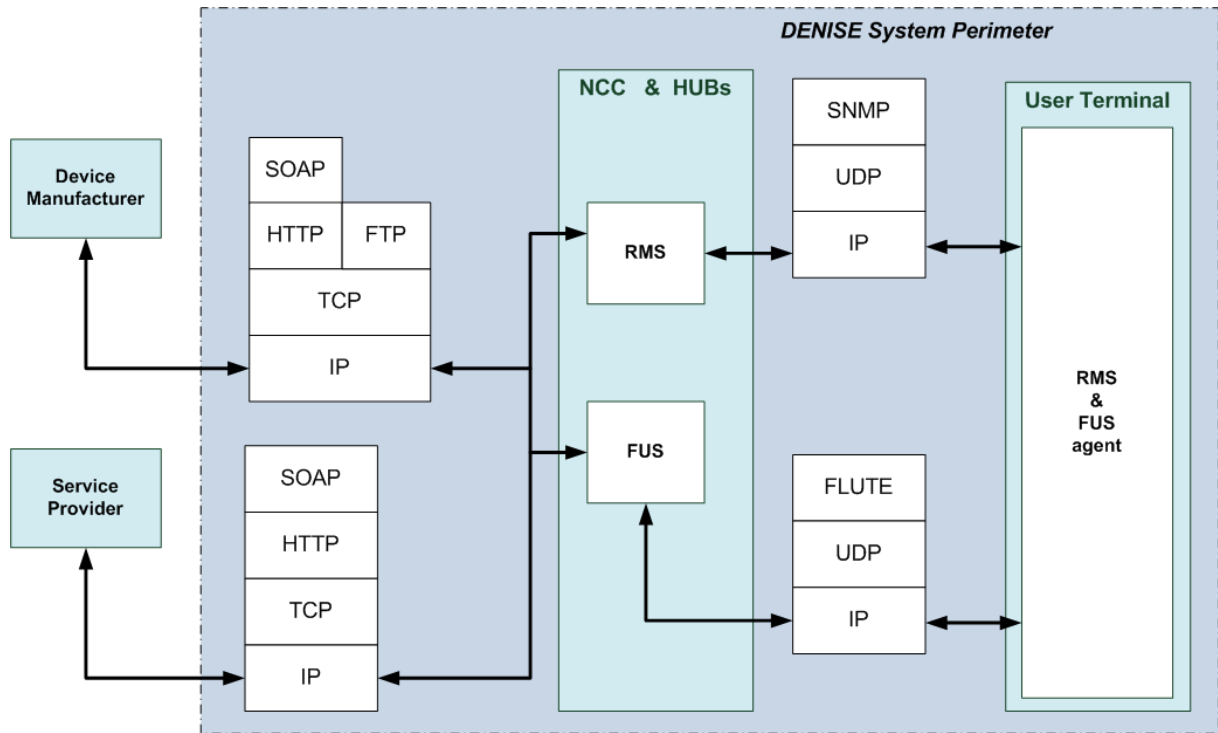

Figure D.1: Terminal Management Plane Protocols

Annex E (informative): Bibliography

- ETSI TS 102 611-1: "Digital Video Broadcasting (DVB); IP Datacast: Implementation Guidelines for Mobility; Part 1: IP Datacast over DVB-H".
- ETSI TS 102 611-2: "Digital Video Broadcasting (DVB); IP Datacast: Implementation Guidelines for Mobility; Part 2: IP Datacast over DVB-SH".
- ETSI TS 102 470-2: "Digital Video Broadcasting (DVB); IP Datacast: Program Specific Information (PSI)/Service Information (SI); Part 2: IP Datacast over DVB-SH".
- ETSI TS 102 471: "Digital Video Broadcasting (DVB); IP Datacast over DVB-H: Electronic Service Guide (ESG)".
- ETSI TS 102 472: "Digital Video Broadcasting (DVB); IP Datacast over DVB-H: Content Delivery Protocols".
- ETSI TS 102 474: "Digital Video Broadcasting (DVB); IP Datacast over DVB-H: Service Purchase and Protection".
- ETSI TS 102 611-1: "Technical Specification Digital Video Broadcasting (DVB); IP Datacast: Implementation Guidelines for Mobility; Part 1: IP Datacast over DVB-H".
- ETSI TS 102 611-2: "IP Datacast over DVB-SH: Implementation Guidelines for Mobility; Part 2: IP Datacast over DVB-SH".
- ETSI TS 133 102: "Universal Mobile Telecommunications System (UMTS); LTE; 3G security; Security architecture (3GPP TS 33.102 version 9.4.0 Release 9)".
- IETF RFC 2406: "IP Encapsulating Security Payload", Network working group, Internet Engineering Task Force (IETF).
- IETF RFC 3550: "RTP: A Transport Protocol for Real-Time Applications".
- IETF RFC 4306 "Internet Key Exchange (IKEv2) Protocol" Network working group, Internet Engineering Task Force.

History

| Document history | | |
|-------------------------|---------------|-------------|
| V1.1.1 | December 2011 | Publication |
| V1.2.1 | August 2013 | Publication |
| | | |
| | | |
| | | |