

ETSI TS 102 542-3-3 V2.1.1 (2016-04)



**Digital Video Broadcasting (DVB);
Guidelines for the implementation of
DVB-IPTV Phase 1 specifications;
Part 3: Error Recovery;
Sub-part 3: Retransmission (RET)**

EBU
OPERATING EUROVISION

DVB[®]
Digital Video
Broadcasting

ReferenceRTS/JTC-DVB-360-3-3

Keywordsbroadcasting, digital, DVB, IP, TV, video

ETSI

650 Route des Lucioles
F-06921 Sophia Antipolis Cedex - FRANCE

Tel.: +33 4 92 94 42 00 Fax: +33 4 93 65 47 16

Siret N° 348 623 562 00017 - NAF 742 C
Association à but non lucratif enregistrée à la
Sous-Préfecture de Grasse (06) N° 7803/88

Important notice

The present document can be downloaded from:
<http://www.etsi.org/standards-search>

The present document may be made available in electronic versions and/or in print. The content of any electronic and/or print versions of the present document shall not be modified without the prior written authorization of ETSI. In case of any existing or perceived difference in contents between such versions and/or in print, the only prevailing document is the print of the Portable Document Format (PDF) version kept on a specific network drive within ETSI Secretariat.

Users of the present document should be aware that the document may be subject to revision or change of status. Information on the current status of this and other ETSI documents is available at
<https://portal.etsi.org/TB/ETSIDeliverableStatus.aspx>

If you find errors in the present document, please send your comment to one of the following services:
<https://portal.etsi.org/People/CommiteeSupportStaff.aspx>

Copyright Notification

No part may be reproduced or utilized in any form or by any means, electronic or mechanical, including photocopying and microfilm except as authorized by written permission of ETSI.

The content of the PDF version shall not be modified without the written authorization of ETSI.
The copyright and the foregoing restriction extend to reproduction in all media.

© European Telecommunications Standards Institute 2016.

© European Broadcasting Union 2016.

All rights reserved.

DECT™, **PLUGTESTS™**, **UMTS™** and the ETSI logo are Trade Marks of ETSI registered for the benefit of its Members.
3GPP™ and **LTE™** are Trade Marks of ETSI registered for the benefit of its Members and of the 3GPP Organizational Partners.
GSM® and the GSM logo are Trade Marks registered and owned by the GSM Association.

Contents

Intellectual Property Rights	4
Foreword.....	4
Modal verbs terminology.....	4
1 Scope	5
2 References	5
2.1 Normative references	5
2.2 Informative references.....	5
3 Abbreviations	5
4 Example of messaging flow involved in DVB RET retransmission for LMB services.....	6
5 HNED RET parameter configuration via SDP.....	11
5.0 Signalling of HNED RET parameters	11
5.1 SDP example for RET-enabled CoD.....	12
5.2 SDP example for RET-enabled LMB.....	12
History	14

Intellectual Property Rights

IPRs essential or potentially essential to the present document may have been declared to ETSI. The information pertaining to these essential IPRs, if any, is publicly available for **ETSI members and non-members**, and can be found in ETSI SR 000 314: "*Intellectual Property Rights (IPRs); Essential, or potentially Essential, IPRs notified to ETSI in respect of ETSI standards*", which is available from the ETSI Secretariat. Latest updates are available on the ETSI Web server (<https://ipr.etsi.org/>).

Pursuant to the ETSI IPR Policy, no investigation, including IPR searches, has been carried out by ETSI. No guarantee can be given as to the existence of other IPRs not referenced in ETSI SR 000 314 (or the updates on the ETSI Web server) which are, or may be, or may become, essential to the present document.

Foreword

This Technical Specification (TS) has been produced by Joint Technical Committee (JTC) Broadcast of the European Broadcasting Union (EBU), Comité Européen de Normalisation ELECTrotechnique (CENELEC) and the European Telecommunications Standards Institute (ETSI).

NOTE: The EBU/ETSI JTC Broadcast was established in 1990 to co-ordinate the drafting of standards in the specific field of broadcasting and related fields. Since 1995 the JTC Broadcast became a tripartite body by including in the Memorandum of Understanding also CENELEC, which is responsible for the standardization of radio and television receivers. The EBU is a professional association of broadcasting organizations whose work includes the co-ordination of its members' activities in the technical, legal, programme-making and programme-exchange domains. The EBU has active members in about 60 countries in the European broadcasting area; its headquarters is in Geneva.

European Broadcasting Union
CH-1218 GRAND SACONNEX (Geneva)
Switzerland
Tel: +41 22 717 21 11
Fax: +41 22 717 24 81

The Digital Video Broadcasting Project (DVB) is an industry-led consortium of broadcasters, manufacturers, network operators, software developers, regulatory bodies, content owners and others committed to designing global standards for the delivery of digital television and data services. DVB fosters market driven solutions that meet the needs and economic circumstances of broadcast industry stakeholders and consumers. DVB standards cover all aspects of digital television from transmission through interfacing, conditional access and interactivity for digital video, audio and data. The consortium came together in 1993 to provide global standardization, interoperability and future proof specifications.

The present document is part 3, sub-part 3 of a multi-part deliverable. Full details of the entire series can be found in part 1.

Modal verbs terminology

In the present document "**shall**", "**shall not**", "**should**", "**should not**", "**may**", "**need not**", "**will**", "**will not**", "**can**" and "**cannot**" are to be interpreted as described in clause 3.2 of the [ETSI Drafting Rules](#) (Verbal forms for the expression of provisions).

"**must**" and "**must not**" are **NOT** allowed in ETSI deliverables except when used in direct citation.

1 Scope

The present document is designed as a companion document to help implement the DVB-IPTV Phase 1 specification Transport of MPEG2-TS Based DVB Services over IP Based Networks [1], which is referred to as the Handbook.

Part 3 of this multi-part deliverable deals with error recovery technologies. The present document provides guidelines on the Retransmission (RET) technology.

2 References

2.1 Normative references

References are either specific (identified by date of publication and/or edition number or version number) or non-specific. For specific references, only the cited version applies. For non-specific references, the latest version of the referenced document (including any amendments) applies.

Referenced documents which are not found to be publicly available in the expected location might be found at <http://docbox.etsi.org/Reference>.

NOTE: While any hyperlinks included in this clause were valid at the time of publication, ETSI cannot guarantee their long term validity.

The following referenced documents are necessary for the application of the present document.

- [1] ETSI TS 102 034: "Digital Video Broadcasting (DVB); Transport of MPEG-2 TS Based DVB Services over IP Based Networks".

2.2 Informative references

References are either specific (identified by date of publication and/or edition number or version number) or non-specific. For specific references, only the cited version applies. For non-specific references, the latest version of the referenced document (including any amendments) applies.

NOTE: While any hyperlinks included in this clause were valid at the time of publication, ETSI cannot guarantee their long term validity.

The following referenced documents are not necessary for the application of the present document but they assist the user with regard to a particular subject area.

- [i.1] ETSI TS 102 542-1: "Digital Video Broadcasting (DVB); Guidelines for the implementation of DVB-IPTV Phase 1 specifications; Part 1: Core IPTV Functions".
-

3 Abbreviations

For the purposes of the present document, the following abbreviations apply:

CoD	Content on Demand
DA	Destination Address
DP	Destination Port
DVB	Digital Video Broadcasting
GA	Group Address
HNED	Home Network End Device
IETF	Internet Engineering Task Force
IGMP	Internet Group Management Protocol
LMB	Live Media Broadcast
MBwTM	Media Broadcast with Trick Modes
MC	Multicast
RET	Retransmission
RTP	Real-time Transport Protocol
RTCP	Real-time Transport Control Protocol

RTCP FB	RTCP FeedBack
RTCP FF	RTCP FeedForward
RTCP RR	RTCP Receiver Report
RTCP RSI	RTCP Receiver Summary Information
RTCP SDES	RTCP Source DEscription
RTSP	Real Time Streaming Protocol
SA	Source Address
SDP	Session Description Protocol
SP	Source Port
SSRC	Synchronization SouRCe
UC	UniCast
XML	eXtensible Markup Language

4 Example of messaging flow involved in DVB RET retransmission for LMB services

DVB retransmission solution for LMB services builds on the DVB RTP retransmission solution for CoD services, but has additional flexibilities and parameters, in order to make the solution sufficiently scalable. In this paragraph an architecture example and related RTP/RTCP message flows for a RET-enabled LMB service from the HNED's point of view are shown. Figure 1 shows the considered example architecture. This example makes use of IPv4 techniques. A similar message flow can also be achieved by IPv6 techniques but this possibility is not covered here.

The Head-end sources the multicast streams (carrying the LMB services), which the HNEDs can join by means of the IGMP protocol. The LMB service is RET-enabled and the HNEDs have been configured with RET DVB parameters, including network/transport address of the LMB RET server(s). In this example an HNED equipped with a DVB RET client can interact with the LMB RET server both in unicast and multicast way. From the HNED point of view, three different RTP sessions can be considered:

- 1) The original RTP multicast session, in which the Head-end sources the RTP multicast streams. The RET-enabled HNED issues in this session the unicast RTCP messages for retransmission requesting (RTCP Feedback messages) and for status reporting (RTCP Receiver Reports) to the LMB Retransmission server, hosting the RTCP (Feedback) target for the original RTP multicast session (depicted as a dashed line in figure 4.1).
- 2) The unicast RTP retransmission session in which the LMB RET server responds to the RTCP retransmission requests received from the HNEDs in the original RTP multicast session. In this session, the RET client of the HNED may also provide status reporting with respect to the unicast RTP retransmission stream towards the LMB RET server.
- 3) There may be optionally also a multicast RTP retransmission stream, which can be used by the LMB RET server to address individual network packet loss events in the original RTP multicast session that impact multiple HNEDs (packet loss event 1 in figure 4.1). This dedicated RTP session may not only carry RTP retransmissions packets but also RTCP Feedforward messages, which advertise packet loss events with the purpose to suppress retransmission requesting.

NOTE: Such RTCP feedforward message is a unicast RTCP Feedback message from a DVB RET client that is relayed by the LMB RET server over the retransmission multicast session towards all DVB RET clients downstream from the LMB RET server. This DVB RET client could be an "upstream" client - as depicted in the figure 4.1 - or a subset of the HNEDs downstream of the LMB RET server.

The three different sessions are differentiated by means of different transport addresses (IP source and destination addresses and ports) and have in general different SSRC identifiers (RTP layer).

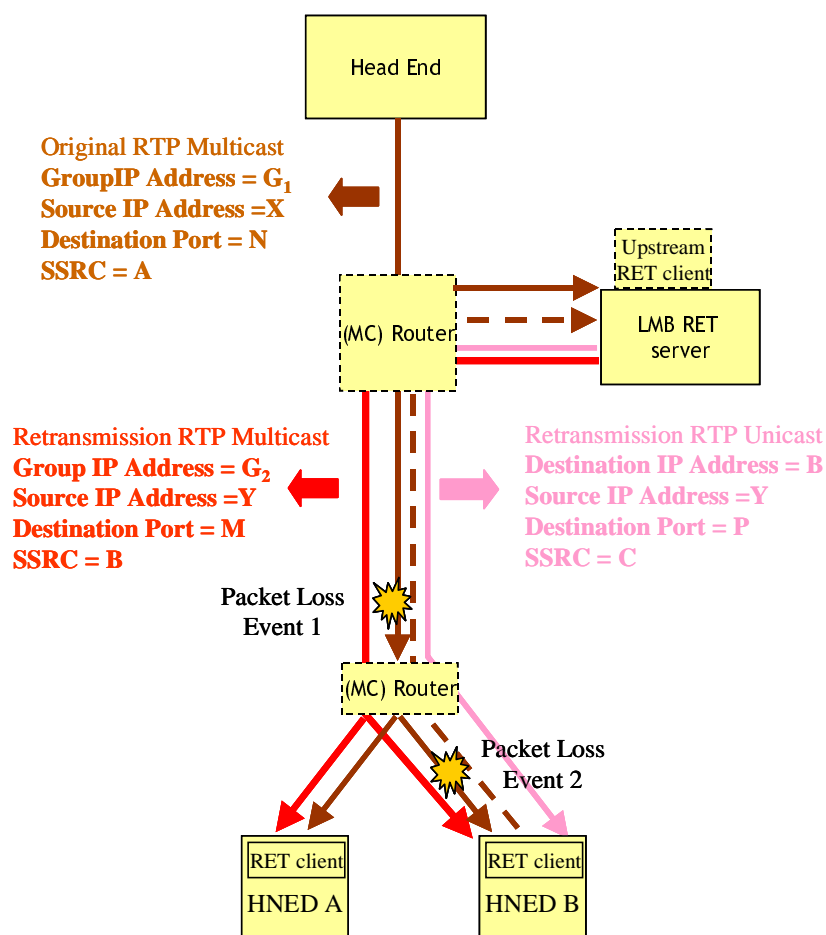

Figure 4.1: Architecture example for a RET-enabled LMB service

The following messaging flows is an illustrative example of the interactions involved in a DVB RET-enabled LMB service in which the three RTP sessions as explained above are present. The focus is on RTCP message exchange and DVB RET client behaviour.

The scenario considered is the following:

- A RET-enabled HNED connects to a LMB service ("channel A") with IGMP, which establishes the original RTP multicast session from the HNED point of view. The HNED also connects to the LMB multicast retransmission session by means of IGMP. This session connection occurs every time the HNED changes channel. When packet loss takes place, this is detected by the RET client in the HNED. In this case this is packet loss impacting only one HNED (e.g. the packet loss is caused by a failure on the access link). When the HNED requests the retransmission and the LMB RET server responds with a unicast retransmission, the retransmission session is established. A second packet loss event takes place downstream of the LMB RET server, but now impacts multiple HNEDs. In this case the LMB RET server responds with a retransmission in the RTP multicast retransmission session.
- After some time the HNED changes channel (channel B). During the time the HNED receives channel B (in the new original multicast session), the HNEDs detects several packet loss events, but all interaction with the LMB RET server occurs solely in unicast.
- After some time the HNED changes channel (channel C). During this session no packet loss events take place and there is no interaction with the LMB RET server at all.
- After some time the HNED changes channel to channel B again. Several packet loss events take place, and the last packet loss event in the considered scenario takes place upstream from the LMB RET server that is detected by the "upstream retransmission client" entity in the LMB RET server. The LMB RET server relays the RTCP Feedforward message in the RTP retransmission multicast session which suppresses the retransmission request by the HNED. Once the packet is recovered by the LMB RET server (outside the scope of the present document), this packet is retransmitted in the multicast RTP retransmission stream.

More specifically in the considered scenario, some of the DVB RET parameters are configured at the HNED as follows:

- both a unicast and multicast retransmission service is advertised towards the HNEDs with signalling of all transport address related parameters;
- *dvb-t-wait-min* (ms) and *dvb-t-wait-Max* (ms) are configured, meaning that the HNED reports packet loss at a random point in time between *dvb-t-wait-min* and *dvb-t-wait-Max* upon packet loss detection;
- *dvb-t-ret* (ms) is configured, meaning that the HNED can issue a second (third, fourth, ...) retransmission request after getting no response on the previous retransmission request within the time frame as specified by *dvb-t-ret*;
- RTCP-Bye is enabled;
- the HNED is instructed to send RTCP status report messages (RTCP RR) in the original RTP session;
- the HNED is not allowed to send RTCP status report messages (RTCP RR) in the unicast RTP retransmission session.

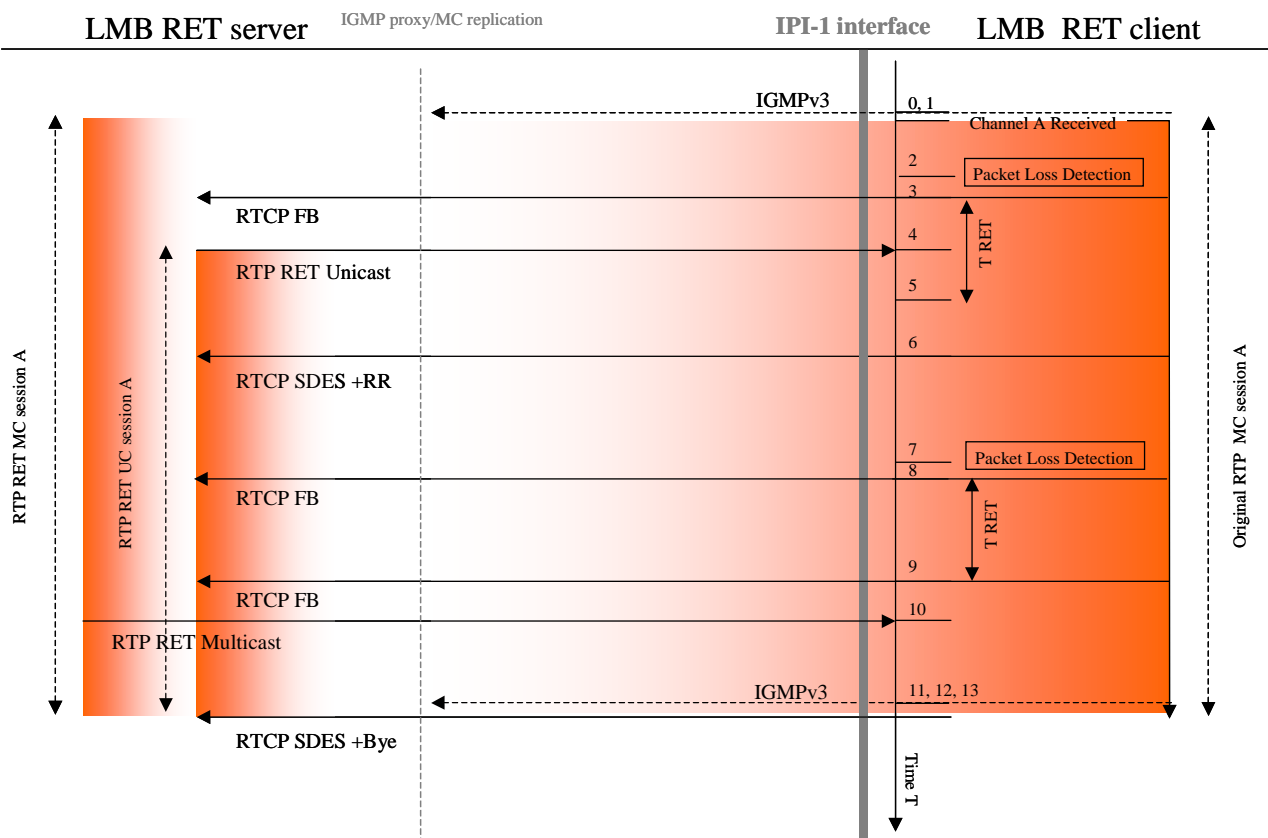

Figure 4.2

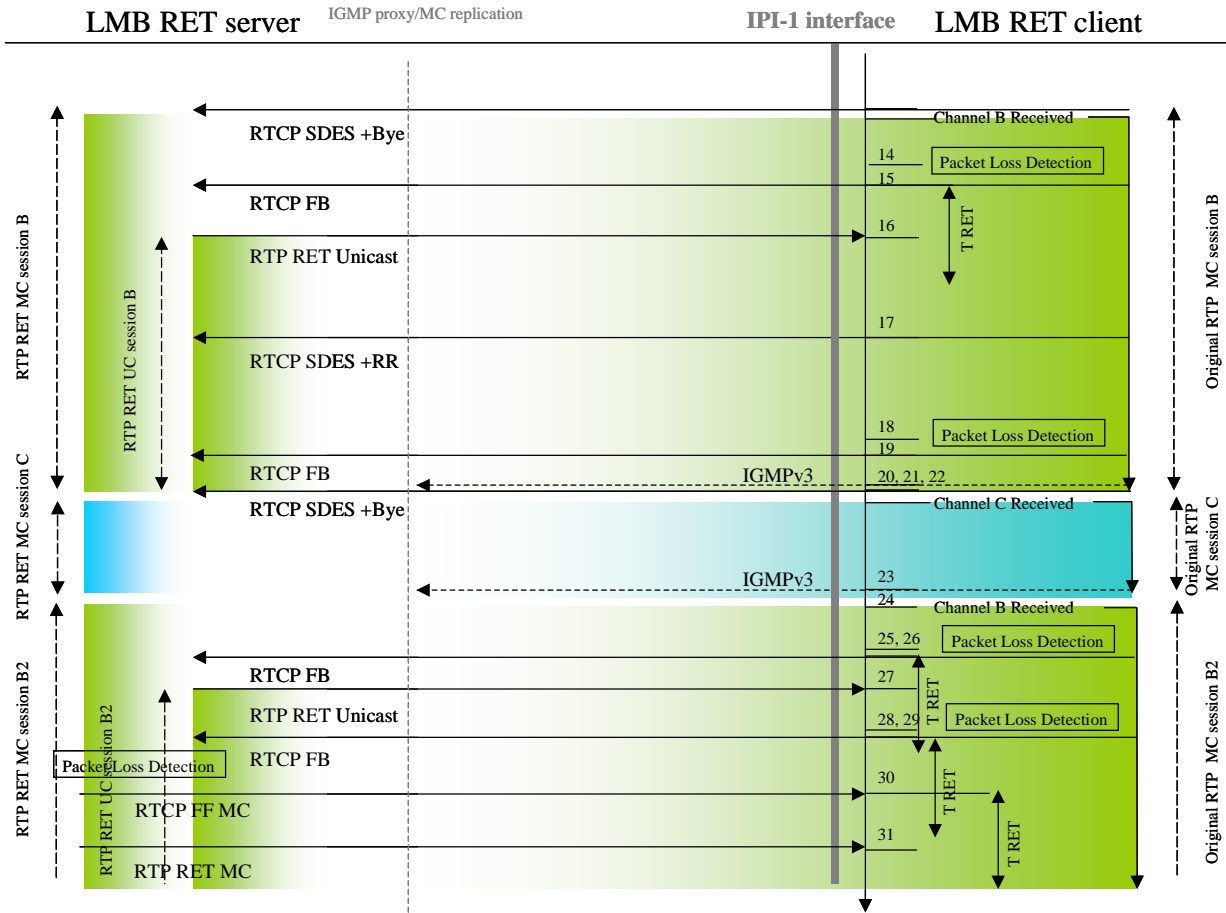

Figure 4.3

Table 4.1 describes in more detail the different events and message exchanges for the particular example scenario.

Table 4.1: Message exchanges and triggering events for a RET enabled LMB service with support for Multicast RTP retransmission (example)

Time (T)	RTP/RTCP message reception/transmission/Event	HNED timing	RTP session initiation/closure
0	IGMPv3 message exchange to join RTP original session (channel A) and RTP RET MC session (for channel A)		Original RTP MC session and MC RTP RET session established.
1	First RTP packets MC group Ch A received (GA=G1; SA=X; DP=N/N+1; SSRC=A)		
2	Packet Loss detection by HNED		
3	RTCP FB message sent by HNED (DA=Y; SA=Z; DP=MA; SP=R, SSRC packet sender=Z; SSRC media source=A)	Message sent at random point in time between $T_2 + T_{min}$ and $T_2 + T_{max}$; DVB-T-RET count-down started	
4	RTP RET packet received by HNED (DA=Z; SA=Y; DP=R; SP=VA, SSRC=T)	RTP packet is received by HNED before DVB-T-RET is elapsed after T_3	UC RET RTP session established.
5		(DVB-T-RET now elapsed since T_3 , but nothing happens, as RET packet received)	
6	RTCP SDES+RR message sent by HNED (DA=Y; SA=Z; DP=MA; SP=R, SSRC packet sender=Z; SSRC media source=A)		

Time (T)	RTP/RTCP message reception/transmission/Event	HNED timing	RTP session initiation/closure
7	Packet Loss detection by HNED		
8	RTCP FB message sent by HNED (DA=Y; SA=Z; DP=M _A ; SP=R, SSRC packet sender=Z; SSRC media source=A)	Message sent At random point in time between T ₇ + T _{min} and T ₇ + T _{max} ; DVB-T-RET count down started	
9	DVB-T-RET elapsed prior to reception of missing packet (as original packet or as RET packet) or reception of RTCP FF message ; RTCP FB message is re-sent by HNED (DA=Y; SA=Z; DP=M _A ; SP=R, SSRC packet sender=Z; SSRC media source=A)	DVB-T-RET count down started	
10	MC RET packet received (= reported missing packet) (GA=G _{1R} ; SA=Y; DP=N; SSRC=A)	Received before DVB T-RET has elapsed since T ₉	
11	End-user zaps to new channel B: IGMPv3 message exchange to <ul style="list-style-type: none"> leave MC RTP original session and RTP RET MC session (channel A) join RTP original session (channel B) and RTP RET MC session (for channel B) 		New Original RTP MC session and MC RTP RET session established.
12	RTCP SDES + Bye Message sent by HNED (DA=Y; SA=Z; DP=M _A ; SP=R, SSRC packet sender=Z; SSRC media source=A)		HNED closes explicitly the RTP RET UC session.
13	First RTP packets MC group Ch B received (GA=G ₂ ; SA=X; DP=N/N+1; SSRC=B)		
14	Packet Loss detection by HNED		
15	RTCP FB message sent by HNED (DA=Y; SA=Z; DP=M _B ; SP=R, SSRC packet sender=Z; SSRC media source=B)	Message sent at random point in time between T ₁₄ + T _{min} and T ₁₄ + T _{max} ; DVB T-RET count down started	
16	RTP RET packet received by HNED (DA=Z; SA=Y; DP=R; SP=V _B , SSRC=T)	RTP packet is received by HNED before DVB T-RET is elapsed after T ₁₅	Unicast RTP RET session established.
17	RTCP SDES+RR message sent by HNED (DA=Y; SA=Z; DP=M _B ; SP=R, SSRC packet sender=Z; SSRC media source=B)		
18	Packet Loss detection by HNED		
19	RTCP FB message sent by HNED (DA=Y; SA=Z; DP=M _B ; SP=R, SSRC packet sender=Z; SSRC media source=B)	Message sent At random point in time between T ₁₈ + T _{min} and T ₁₈ + T _{max} ; DVB T-RET count down started	
20	End-user zaps to new channel C: IGMPv3 message exchange to <ul style="list-style-type: none"> -leave RTP original session and RTP RET MC session (channel B) -join RTP original session (channel B) and RTP RET MC session (for channel C) 		New Original RTP MC session and MC RTP RET session established.
21	RTCP SDES + Bye Message sent by HNED (DA=Y; SA=Z; DP=M _B ; SP=R, SSRC packet sender=Z; SSRC media source=B)		HNED closes explicitly the RTP RET UC session.

Time (T)	RTP/RTCP message reception/transmission/Event	HNED timing	RTP session initiation/closure
22	First RTP packets MC group Ch C received (GA=G3; SA=X; DP=N/N+1; SSRC=C)		
23	End-user zaps to channel B: IGMPv3 message exchange to <ul style="list-style-type: none"> leave RTP original session and RTP RET MC session (channel C) join RTP original session (channel B) and RTP RET MC session (for channel B) 		Unicast RTP RET session for channel C was never established! New Original RTP MC session and MC RTP RET session established.
24	First RTP packets MC group Ch B received (GA=G2; SA=X; DP=N/N+1; SSRC=C)		
25	Packet Loss detection by HNED		
26	RTCP FB message sent by HNED (DA=Y; SA=Z; DP=M_B; SP=R, SSRC packet sender=Z; SSRC media source=B)	Message sent at random point in time between $T_{25} + T_{min}$ and $T_{25} + T_{max}$; DVB T-RET count down started	
27	RTP RET packet received by HNED (DA=Z; SA=Y; DP=R; SP=V_B, SSRC=T)	RTP packet is received by HNED before DVB T-RET is elapsed after T_{26}	Unicast RTP RET session established.
28	Packet Loss detection by HNED (and by LMB RET server)		
29	RTCP FB message sent by HNED (DA=Y; SA=Z; DP=M_B; SP=R, SSRC packet sender=Z; SSRC media source=B)	Message sent at random point in time between $T_{28} + T_{min}$ and $T_{28} + T_{max}$; DVB T-RET count down started	
30	Reception of RTCP FF message (GA=G2_R; SA=Y; DP=N; SSRC=B)	Before DVB-T-RET was elapsed since T_{29} ; DVB-T-RET count down re-started	
31	Reception of RTCP MC RET packet (GA=G2_R; SA=Y; DP=N; SSRC=B)	Reported missing packet received, before DVB-T-RET was elapsed since T_{30}	

5 HNED RET parameter configuration via SDP

5.0 Signalling of HNED RET parameters

The DVB RET-related parameters can be signalled to the HNED with XML, which is done either via Broadcast Discovery records (ETSI TS 102 034 [1], clause 5.2.6.2 for LMB services) or by means of XML descriptions transmitted with RTSP ANNOUNCE method or RTSP DESCRIBE method response (for RTSP clients of LMB services or CoD/MBwTM services). The DVB RTSP client is required to support the reception of descriptions in XML format but additionally, a DVB RTSP client supporting DVB retransmission, should also understand session descriptions in SDP format.

This clause contains an example of an SDP description for a RET-enabled CoD and an example of an SDP description for a RET-enabled LMB RTP session. They include the RET relevant parameters/attributes including the ones defined in the various IETF references for DVB RET, but the focus is here on how to embed those RET parameters defined specifically (and exclusively) in the DVB handbook in an SDP description.

More specifically, the DVB-specific parameter "dvb-t-ret" is a format-specific parameter that can only be specified in the m-line associated with the original RTP packet flow and "dvb-disable-rtcp-rr" is a DVB-specific attribute that can be specified in SDP per c-line or per m-line both for the original RTP and the unicast retransmission RTP flows.

The parameter "dvb-t-ret" and attribute "dvb-disable-rtcp-rr" can be included in the SDP file both for LMB and for CoD services. Additionally, for RET-enabled LMB services the following DVB media-specific parameters may be included in the SDP file in the m-line associated with the original RTP session: "dvb-t-wait-min", "dvb-t-wait-max", "dvb-ssrc-bitmask", "dvb-ssrc-upstream-client", "dvb-rsi-mc-ret" and "dvb-enable-bye".

5.1 SDP example for RET-enabled CoD

The SDP example for the RET-enabled COD service describes a SSRC multiplexing scheme. In the given example, the HNED shall not issue RTCP RR reports both with respect to the Retransmission and Original RTP packet flows. The original packets are buffered for 1 second, and there should be at least 300 ms between two consecutive RTCP FB messages requesting retransmission for the same packet. The bandwidth that can be maximum consumed by the HNED for its RTCP (FB) reporting is 50 kb/s.

```
v=0
o=dvb-iptv-service-provider-x 2980675221 2980675778 IN IP4 dvb-iptv-service-provider-x.cod-service-
y-with-ret.com
c=IN IP4 192.0.2.0
a=dvb-disable-rtcp-rr
m=video 49170 RTP/AVPF 33 96
a=rtpmap:33 MP2T/90000
a=ssrc:123321 cname:cod-server-89@dvb-iptv-service-provider-x.com
a=rtcp-fb:33 nack
a=fmtp:33 dvb-t-ret=300
b=RR:50
a=rtpmap:96 rtx/90000
a=ssrc:232345 cname:cod-server-89@dvb-iptv-service-provider-x.com
a=fmtp:96 apt=33;rtx-time=1000
```

5.2 SDP example for RET-enabled LMB

The SDP example for the RET-enabled LMB service describes a session multiplexing scheme in which retransmissions can be sent both unicast and multicast mode. In the given example, the HNED can send in the original session RTCP FB messages in stand-alone (non-compound) mode. The original packets are buffered for 1 second by the LMB RET server, and there should be at least 300 ms between two consecutive RTCP FB messages requesting retransmission for the same packet. The HNED shall respect a waiting time of 200 ms before issuing an RTCP FB message upon packet loss detection, unless it is an early reporter, for which the "dvb-ssrc-bitmask" is signalled. The HNED is expected to issue the RTCP bye in the original RTP session when applicable. In the retransmission flow the RTP and RTCP packets are multiplexed on the same port. The HNED is expected to issue RTCP RR reports in the retransmission session. The bandwidth that can be consumed by the HNED for its RTCP reporting is 5 % of the original stream bandwidth (default value, not signalled). The RTCP RSI messages pertaining to the original MC RTP session are distributed in the MC retransmission RTP session.

```
v=0
o=dvb-iptv-service-provider-x 2980675221 2980675778 IN IP4 dvb-iptv-service-provider-x.lmb--service-
z-with-ret.com
a=rtcp-unicast:rsi
m=video 40000 RTP/AVPF 33
c=IN IP4 224.1.1.1/255
a=source-filter:incl IN IP4 224.1.1.1 8.166.1.1
a=ssrc:123400 cname:head-end-01@dvb-iptv-service-provider-x.com
a=recvonly
a=rtpmap:33 MP2T/90000
a=rtcp:40001 IN IP4 9.30.30.1
a=rtcp-fb:33 nack
a=rtcp-rsize
a=fmtp:33 dvb-t-ret=400;dvb-t-wait-min=200;dvb-t-wait-max=200;dvb-ssrc-bitmask=3;dvb-ssrc-upstream-
client=123401;dvb-rsi-mc-ret;dvb-enable-bye

m=video 10000 RTP/AVPF 97
c=IN IP4 9.30.30.1
a=ssrc:123800 cname:ret-server-02@dvb-iptv-service-provider-x.com
a=recvonly
a=rtpmap:97 rtx/90000
a=fmtp:97 apt=33;rtx-time=1000;
a=rtcp-mux

m=video 50000 RTP/AVPF 98
c=IN IP4 224.1.1.1/255
a=source-filter:incl IN IP4 224.1.1.1 8.166.1.5
```

```
a=recvonly  
a=rtpmap:98 apt=33;rtx-time=1000  
a=dvb-disable-rtcp-rr
```

History

Document history		
V1.1.1	November 2006	Published as ETSI TR 102 542
V1.2.1	April 2008	Published as ETSI TS 102 542
V1.3.1	January 2010	Publication
V2.1.1	April 2016	Publication