

ETSI TS 102 027-1 V2.1.1 (2003-10)

Technical Specification

**Telecommunications and Internet Protocol
Harmonization Over Networks (TIPHON)
Technology Compliance Specification;
Draft IETF SIP RFC3261;
Part 1: Test Suite Structure and
Test Purposes (TSS&TP) specification**



Reference

RTS/TIPHON-06021-1[2]

Keywords

IP, SIP, telephony, testing, TSS&TP, VoIP

ETSI

650 Route des Lucioles
F-06921 Sophia Antipolis Cedex - FRANCE

Tel.: +33 4 92 94 42 00 Fax: +33 4 93 65 47 16

Siret N° 348 623 562 00017 - NAF 742 C
Association à but non lucratif enregistrée à la
Sous-Préfecture de Grasse (06) N° 7803/88

Important notice

Individual copies of the present document can be downloaded from:

<http://www.etsi.org>

The present document may be made available in more than one electronic version or in print. In any case of existing or perceived difference in contents between such versions, the reference version is the Portable Document Format (PDF). In case of dispute, the reference shall be the printing on ETSI printers of the PDF version kept on a specific network drive within ETSI Secretariat.

Users of the present document should be aware that the document may be subject to revision or change of status. Information on the current status of this and other ETSI documents is available at

<http://portal.etsi.org/tb/status/status.asp>

If you find errors in the present document, send your comment to:

editor@etsi.org

Copyright Notification

No part may be reproduced except as authorized by written permission.
The copyright and the foregoing restriction extend to reproduction in all media.

© European Telecommunications Standards Institute 2003.
All rights reserved.

DECTTM, **PLUGTESTS**TM and **UMTS**TM are Trade Marks of ETSI registered for the benefit of its Members.
TIPHONTM and the **TIPHON logo** are Trade Marks currently being registered by ETSI for the benefit of its Members.
3GPPTM is a Trade Mark of ETSI registered for the benefit of its Members and of the 3GPP Organizational Partners.

Contents

Intellectual Property Rights	5
Foreword.....	5
1 Scope	6
2 References	6
3 Definitions and abbreviations.....	6
3.1 Definitions	6
3.2 Abbreviations	7
4 Test Suite Structure (TSS).....	7
4.1 Introduction	7
4.1.1 SIP Entities	7
4.1.2 General assumptions	8
4.1.3 System under test	9
4.2 Overview of the Test Suite Structure (TSS).....	9
5 Test Purposes (TP)	11
5.1 Introduction	11
5.1.1 TP naming convention	11
5.1.2 State Definitions during a call.....	11
5.1.3 TP structure.....	11
5.2 Test Purposes for Registration.....	12
5.2.1 Registrant.....	12
5.2.1.1 Valid Behaviour	12
5.2.2 Registrar.....	14
5.2.2.1 Valid Behaviour	14
5.2.2.2 Invalid Behaviour.....	18
5.2.2.3 Inopportune Behaviour.....	18
5.3 Test Purposes for Call Control	19
5.3.1 Originating Endpoint	19
5.3.1.1 Call establishment	19
5.3.1.1.1 Valid Behaviour.....	19
5.3.1.1.2 Timers.....	28
5.3.1.2 Call release.....	30
5.3.1.2.1 Valid Behaviour.....	30
5.3.1.2.2 Invalid Behaviour	33
5.3.1.2.3 Timers.....	33
5.3.1.3 Session modification	35
5.3.1.3.1 Valid Behaviour.....	35
5.3.2 Terminating Endpoint	35
5.3.2.1 Call establishment	35
5.3.2.1.1 Valid Behaviour.....	35
5.3.2.1.2 Invalid Behaviour	42
5.3.2.1.3 Timers.....	42
5.3.2.2 Call release.....	44
5.3.2.2.1 Valid Behaviour.....	44
5.3.2.2.2 Invalid Behaviour	48
5.3.2.2.3 Timers.....	49
5.3.2.3 Session modification	49
5.3.2.3.1 Valid Behaviour.....	49
5.3.2.3.2 Invalid Behaviour	50
5.3.3 Proxy.....	50
5.3.3.1 Message processing.....	50
5.3.3.1.1 Request	50
5.3.3.1.2 Response.....	63
5.3.3.1.2.1 Valid Behaviour	63

5.3.3.2	Transaction	74
5.3.3.2.1	Client	74
5.3.3.2.2	Server	79
5.3.4	Redirect Server	86
5.3.4.1	Call establishment	86
5.3.4.1.1	Valid Behaviour	86
5.3.4.2	Call release	88
5.3.4.2.1	Valid Behaviour	88
5.4	Test Purposes for Messaging	88
5.4.1	Registrant	88
5.4.1.1	Valid Behaviour	88
5.4.1.2	Invalid Behaviour	90
5.4.2	Registrar	90
5.4.2.1	Valid Behaviour	91
5.4.2.2	Invalid Behaviour	93
5.4.3	Originating Endpoint	94
5.4.3.1	Valid Behaviour	94
5.4.3.2	Invalid Behaviour	97
5.4.4	Terminating Endpoint	99
5.4.4.1	Valid Behaviour	99
5.4.4.2	Invalid Behaviour	101
5.4.5	Proxy	103
5.4.5.1	Valid Behaviour	103
5.4.5.2	Invalid Behaviour	106
5.4.6	Redirect server	107
5.4.6.1	Valid Behaviour	107
5.4.6.2	Invalid Behaviour	110
History	112

Intellectual Property Rights

IPRs essential or potentially essential to the present document may have been declared to ETSI. The information pertaining to these essential IPRs, if any, is publicly available for **ETSI members and non-members**, and can be found in ETSI SR 000 314: "*Intellectual Property Rights (IPRs); Essential, or potentially Essential, IPRs notified to ETSI in respect of ETSI standards*", which is available from the ETSI Secretariat. Latest updates are available on the ETSI Web server (<http://webapp.etsi.org/IPR/home.asp>).

Pursuant to the ETSI IPR Policy, no investigation, including IPR searches, has been carried out by ETSI. No guarantee can be given as to the existence of other IPRs not referenced in ETSI SR 000 314 (or the updates on the ETSI Web server) which are, or may be, or may become, essential to the present document.

Foreword

This Technical Specification (TS) has been produced by ETSI Project Telecommunications and Internet Protocol Harmonization Over Networks (TIPHON).

The present document is part 1 of a multi-part deliverable covering Telecommunications and Internet Protocol Harmonization Over Networks (TIPHON); Conformance Testing for TIPHON Release 3; TIPHON profile for Session Initiation Protocol (SIP), as identified below:

Part 1: "Test Suite Structure and Test Purposes (TSS&TP) specification";

Part 2: "Abstract Test Suite (ATS) and partial Protocol Implementation eXtra Information for Testing (PIXIT) proforma specification".

1 Scope

The present document proposes a Test Suite Structure and Test Purposes (TSS&TP) for the SIP protocol as described in RFC 3261, "Session Initiation Protocol" issued in June 2002.

2 References

The following documents contain provisions which, through reference in this text, constitute provisions of the present document.

- References are either specific (identified by date of publication and/or edition number or version number) or non-specific.
- For a specific reference, subsequent revisions do not apply.
- For a non-specific reference, the latest version applies.

Referenced documents which are not found to be publicly available in the expected location might be found at <http://docbox.etsi.org/Reference>.

- [1] IETF RFC 3261: "SIP: Session Initiation Protocol".
- [2] IETF RFC 2327: "SDP: Session Description Protocol".
- [3] ISO/IEC 9646-1: "Information technology - Open Systems Interconnection - Conformance testing methodology and framework - Part 1: General concepts".
- [4] ISO/IEC 9646-2: "Information technology - Open Systems Interconnection - Conformance testing methodology and framework - Part 2: Abstract Test Suite specification".
- [5] ISO/IEC 9646-3: "Information technology - Open Systems Interconnection - Conformance testing methodology and framework - Part 3: The Tree and Tabular Combined Notation".
- [6] ETSI ETS 300 406: "Methods for Testing and Specification (MTS); Protocol and profile conformance testing specifications; Standardization methodology".

3 Definitions and abbreviations

3.1 Definitions

For the purposes of the present document, the following terms and definitions apply:

- terms defined in RFC 3261 [1];
- terms defined in ISO/IEC 9646-1, -2 and -3 ([3], [4] and [5]).

callee: SIP entity that is requested to participate to a session by receiving an INVITE message

caller: SIP entity that initiates a session by sending an INVITE message

dialog: identifier defined as the combination of the remote address, local address, and Call-ID

inopportune: test group that handles invalid signalling exchanges of messages, which are properly structured and correctly encoded

Invalid (I): test group that handles valid signalling exchanges of messages, which are either not properly structured or incorrectly encoded

Test Purpose (TP): non-formal high-level description of a test, mainly using text

NOTE: This test description can be used as the basis for a formal test specification (e.g. Abstract Test Suite in TTCN). See ISO/IEC 9646.

Valid (V): test group that handles valid signalling exchanges of messages, which are properly structured and correctly encoded

3.2 Abbreviations

For the purposes of the present document, the following abbreviations apply:

ATS	Abstract Test Suite
CE	Call Establishment
CR	Call Release
I	Invalid
IUT	Implementation Under Test
MG	Messaging
O	Inopportune
OE	Originating Endpoint
PIXIT	Protocol Implementation eXtra Information for Testing
PR	Proxy
RD	ReDirect Server
RG	Registration
RR	RegistraR
RT	RegistranT
SM	Session Modification
TE	Terminating Endpoint
TP	Test Purpose
TSS	Test Suite Structure
UA	User Agent
UAC	User Agent Client
UAS	User Agent Server
V	Valid

4 Test Suite Structure (TSS)

4.1 Introduction

4.1.1 SIP Entities

Test Purposes have been written for SIP entities according to the RFC 3261 [1].

Three kinds of entities are considered successively as IUT:

- User Agent behaving as client or Server.
- Proxy (outbound and simple proxy).
- Redirect Server.

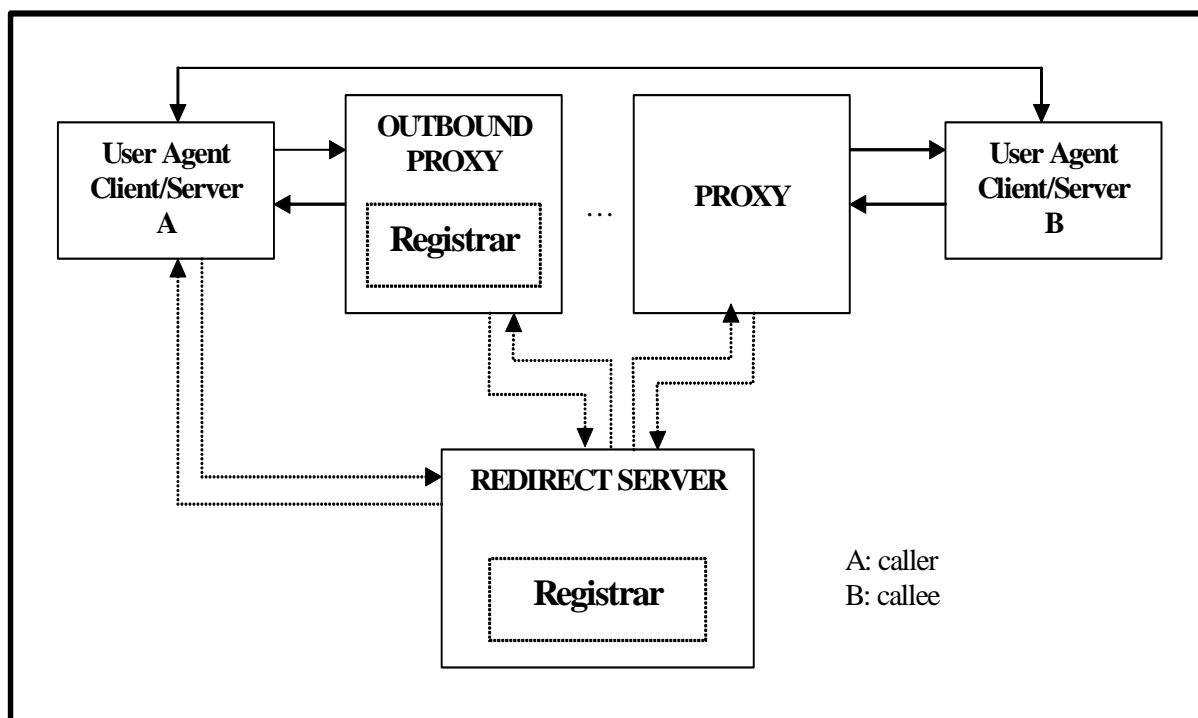

Figure 1: SIP protocol entities

4.1.2 General assumptions

Test Purposes have been written for behaviours requested with "MUST" and conditional "SHOULD" as recommended test.

Several proxy servers may forward the requests, but the test purposes are written from the point of view of one SIP entity only. The client can be either a user agent client or the client portion of a proxy server.

SDP has been considered as the method used to describe the session, but no test purposes have been written to check the SDP content itself as it is out of the scope of the present document.

Proxy, redirect server and registrar shall support both UDP and TCP as transport layer while UA shall support at least UDP.

SIP entities are considered in the present document to be addressed with SIP-URIs, except for test purposes that validate the IUT's behaviour upon reception of non SIP-URIs. The features listed below are not covered by the present document. Reasons are described along with their description:

- ICMP Handling:
 - RFC 3261 [1] states that host, network, port, parameter or protocol errors SHOULD be treated as a 4xx response (Client-Server), which SHOULD therefore cause the server to cease retransmitting the response. Others (source quench ICMP messages and TTL exceeds) SHOULD be ignored.
- Timers T1, T2 (14.3.1 [1]):
 - RFC 3261 [1] states that retransmission of requests other than INVITE and ACK SHOULD be implemented when a SIP client is using an unreliable protocol (UDP).
- OPTION (8 [1]):
 - RFC 3261 [1] states that the OPTION method MUST be supported, but MAY be answered. Therefore, there is no guarantee that the IUT will respond to an option message. A Test Purpose is then not applicable.

- 380 (Alternative Service) message:
 - RFC 3261 [1] states that this message indicates, for an unsuccessful call, that Alternative services are possible. But, the alternative services are described in the message body content, which is not considered.
- TLS:
 - Encrypted transport TLS cannot run over UDP that is the default transport used in the following test. Additionally TLS is optional for UA.
- SIPS URI:
 - As TLS is not covered, the SIPS URIs are not covered too.

The verb "ignore" in test purpose means that the IUT does not react with an error message and does not take into account the element to be ignored. When this element is an undefined Header field, according to 10 [1], proxy shall not remove or modify it.

The adjective "unknown" means in the test purpose not defined in the standard [1] while "non-understood" means unknown from the point of view of the IUT.

The mandatory headers like Call-ID, CSeq, From, To, Via are supposed to be present in all messages as Max-Forwards in Request message without stressing those requirements in each test purpose (see clauses 8.1.1 and 8.2.6 of RFC 3261 [1]).

4.1.3 System under test

In SIP, a client can either sends its request directly to the Request-URI or to its outbound proxy. It can also ask for SIP-URI to a redirect server before sending its request. Test purpose will apply depending of the current tested configuration.

Three kinds of session have been consider in the present document:

- Call using a proxy.
- Direct call with no proxy.
- Call using a redirect server.

4.2 Overview of the Test Suite Structure (TSS)

The Test Suite Structures is based on SIP entities and assumptions as described in clause 4.1.2.

Figure 2 shows the Test Suite Structure (TSS).

Last Sub groups may be subdivided in three subgroups: Valid behaviour (V), Invalid behaviour (I), Inopportune behaviour (O).

Test Suite	Main Functionalities	Role	Functionalities subgroups	Test group		
SIP	Registration	Registrant		V		
		Registrar		V-I-O		
	Call Control	Originating Endpoint	Call establishment		V-Timers	
			Call release		V-I-Timers	
			Session Modification		V	
		Terminating Endpoint	Call establishment		V-I-Timers	
			Call release		V-I-Timers	
			Session Modification		V-I	
		Proxy	Message processing	Request		V-I
				Response		V
			Transaction	Client		V-Timers
				Server		V-Timers
	Redirect server	Call establishment		V		
		Call release		V		
	Messaging	Registrant		V-I		
		Registrar		V-I		
		Originating Endpoint		V-I		
Terminating Endpoint			V-I			
Proxy			V-I			
Redirect Server			V-I			

Figure 2: TSS for SIP

5 Test Purposes (TP)

5.1 Introduction

5.1.1 TP naming convention

Table 1: TP identifier naming convention scheme

Identifier: <protocol>_<main functionality>_<role>_<functionality>_<type>_<nn>	
<protocol>	SIP
<main functionality>	Registration (RG), Call Control (CC), Messaging (MG).
<role>	Registrant (RT), Registrar (RR) Originating Endpoint (OE), Terminating Endpoint (TE), Proxy (PR), Redirect (RD).
<functionality> (optional) (MP),	Call Establishment (CE), Call Release(CR), Session modification (SM), Message processing Transaction (TR).
<sub-functionality> (optional)	Request (RQ), Response(RS), Client(CL), Server(SE)
<type>	Valid Behaviour (V), Invalid Behaviour (I), Inopportune Behaviour (O), Timers (TI).
<nnn>	sequential number (001-999).

5.1.2 State Definitions during a call

For more clarity and consistency, states defined in figures 5 and 7 in [1], have been reused in the wording of test purposes.

5.1.3 TP structure

Each test purpose is decomposed in seven keyword.

- "TPIId" gives a unique identifier to each test purpose.
- "Status" specifies whether the test purpose or the group is mandatory or optional according to in RFC 3261 [1]. The group status applies to all test purposes belonging to this group.
- "Ref." outlines the references in RFC 3261 [1] used to create the test purpose.
- "Purpose" describes the objective of the test.

5.2 Test Purposes for Registration

5.2.1 Registrant

Group selection: Registration being listed as an option, the test purpose is applicable if the SUT is declared as supporting periodic registration and can behave as User Agent.

Status: Optional

5.2.1.1 Valid Behaviour

TPId: SIP_RG_RT_V_001

Status: Mandatory

Ref: 10.2 [1]

Purpose: Ensure that the IUT, in order to be registered, sends a REGISTER request to its registrar, without user name in the Request-URI and with a SIP-URI as request-URI.

TPId: SIP_RG_RT_V_002

Status: Mandatory

Ref: 10.3 [1]

Purpose: Ensure that the IUT having sent a REGISTER request is able to receive a Success (200 OK) response containing its current registration list in the Contact header and an expires parameter in the header.

TPId: SIP_RG_RT_V_003

Status: Optional

Ref: 10.2.6 [1]

Purpose: Ensure that the IUT, in order to be registered, sends a REGISTER request to the its pre-configured registrar address and without username.

TPId: SIP_RG_RT_V_004

Status: Optional

Ref: 10.2.6 [1]

Purpose: Ensure that the IUT, in order to be registered, sends a REGISTER request to host part of address of record as the Request-URI and without username.

TPId: SIP_RG_RT_V_005

Status: Optional

Ref: 10.2.6 1

Purpose: Ensure that the IUT, in order to be registered, sends a REGISTER request to the well-known "all SIP servers" multicast address "sip.mcast.net" (224.0.1.75) and without username.

- TPId:** SIP_RG_RT_V_006
- Status:** Mandatory
- Ref:** 10.2.4 [1]
- Purpose:** Ensure that the IUT, already registered, sends at least one REGISTER request, during the shortest lifetime indicated in the Contact parameters of the Success (200 OK) response it has received.
-
- TPId:** SIP_RG_RT_V_007
- Status:** Recommended
- Ref:** 8.1.3.5 [1], 22.2 [1]
- Purpose:** Ensure that the IUT having sent a REGISTER message, on receipt of an Unauthorized (401 Unauthorized) response including a WWW-Authenticate header, repeats its REGISTER request with an Authorization header and with an incremented Cseq value.
-
- TPId:** SIP_RG_RT_V_008
- Status:** Mandatory
- Ref:** 10.2 [1]
- Purpose:** Ensure that the IUT, in order to be registered, sends a REGISTER request to its registrar, with a address-of record in the To header of type SIP URI.
-
- TPId:** SIP_RG_RT_V_009
- Status:** Mandatory
- Ref:** 10.2 [1]
- Purpose:** Ensure that the IUT, in order to be registered, sends a REGISTER request to its registrar, with the same URI in the From and the To header.
-
- TPId:** SIP_RG_RT_V_010
- Status:** Mandatory
- Ref:** 10.2 [1]
- Purpose:** Ensure that the IUT having sent a REGISTER request, does not send a new registration before the REGISTER request has timed out in case of no final response is received.
-
- TPId:** SIP_RG_RT_V_011
- Status:** Mandatory
- Ref:** 10.2 [1]
- Purpose:** Ensure that the IUT having sent a REGISTER request, will increment the CSeq value by one in the next new REGISTER request with the same Call-ID.

TPId: SIP_RG_RT_V_012

Status: Recommended

Ref: 10.2.4 [1]

Purpose: Ensure that the IUT, already registered, sends at least one REGISTER request, during the shortest lifetime indicated in the Contact parameters of the Success (200 OK) response it has received, using the same Call-ID as in the previous REGISTER request.

TPId: SIP_RG_RT_V_013

Status: Recommended

Ref: 10.2.2 [1]

Purpose: Ensure that the IUT, in order to remove an existing binding sends a REGISTER request, with Expires parameter set to zero in the Contact headers or an Expires header set to 0 when Contact field is set to "*".

5.2.2 Registrar

GroupSelection: IUT is a proxy or a redirect server entity

5.2.2.1 Valid Behaviour

TPId: SIP_RG_RR_V_001

Status: Mandatory

Ref: 10.3 [1]

Purpose: Ensure that the IUT on receipt of a REGISTER and without user name in the Request-URI, sends a Success (200 OK) response, containing all current bindings listed in the Contact header, with the expires parameter for each Contact value.

TPId: SIP_RG_RR_V_002

Status: Mandatory

Ref: 10.3 [1]

Purpose: Ensure that the IUT on receipt of a REGISTER request including multiple Contact header sends a Success (200 OK) response, and adds these addresses to the current bindings list.

TPId: SIP_RG_RR_V_003

Status: Mandatory

Ref: 10.2 [1], 10.3 [1]

Purpose: Ensure that the IUT on receipt of a successive REGISTER with the same Call-ID but with different Contact header answers successively each of them with a Success (200 OK) response, and adds these addresses to the current bindings list.

TPId: SIP_RG_RR_V_004

Status: Optional

Ref: 10.2 [1], 10.3 [1]

Purpose: Ensure that the IUT on receipt of a REGISTER request including a From header addressing a different entity than that addressed by the To header (third party registration), sends a Success (200 OK) response.

TPId: SIP_RG_RR_V_005

Status: Mandatory

Ref: 10.2 [1], 10.3 [1]

Purpose: Ensure that the IUT on receipt of periodic REGISTER request with the same Call-ID and Contact header, and with an increasing CSeq number answers each of them with a Success (200 OK) response.

TPId: SIP_RG_RR_V_006

Status: Mandatory

Ref: 10.3 [1], 10.2 [1]

Purpose: Ensure that the IUT when the UA is already registered, on receipt of REGISTER request without Contact header, sends a Success (200 OK) response including the expiration time of the registration in an expires parameter in theContact header.

TPId: SIP_RG_RR_V_007

Status: Mandatory

Ref: 10.3 [1], 10.2 [1]

Purpose: Ensure that the IUT on receipt of a REGISTER request including an Expires header, sends a Success (200 OK) response.

TPId: SIP_RG_RR_V_008

Status: Mandatory

Ref: 10.3 [1], 10.2 [1]

Purpose: Ensure that the IUT on receipt of a REGISTER request including an Expires parameter in the Contact header, sends a Success (200 OK) response.

TPId: SIP_RG_RR_V_009

Status: Mandatory

Ref: 10.3 [1], 20.10 [1]

Purpose: Ensure that the IUT on receipt of a REGISTER request including a Contact header without display name, sends a Success (200 OK) response.

TPId: SIP_RG_RR_V_010

Status: Mandatory

Ref: 10.3 [1]

Purpose: Ensure that the IUT when a binding already registered, on receipt of a REGISTER request including a Contact header set to * and an Expires header set to zero, and Call-ID is the same as the stored Call-ID value and CSeq is greater than the stored CSeq value of that binding, removes that binding and sends a Success (200 OK) response.

TPId: SIP_RG_RR_V_011

Status: Mandatory

Ref: 10.3 [1]

Purpose: Ensure that the IUT when a binding already registered, on receipt of a REGISTER request including a Contact header set to * and an Expires header set to zero, and Call-ID is different from the stored Call-ID value of that binding, removes that binding and sends a Success (200 OK) response.

TPId: SIP_RG_RR_V_012

Status: Mandatory

Ref: 10.3 [1]

Purpose: Ensure that the IUT when a binding already registered, on receipt of a REGISTER request including a Contact header set to an address which is not in the bindings list, and the received expiration time other than zero, and Call-ID is different from the stored Call-ID value of that binding, adds that binding to the list and sends a Success (200 OK) response.

TPId: SIP_RG_RR_V_013

Status: Mandatory

Ref: 10.3 [1]

Purpose: Ensure that the IUT when a binding already registered, on receipt of a REGISTER request including a Contact header set to an address which is in the bindings list with a Call-ID different from the value stored for that binding, and an expiration time other than zero, sends a Success (200 OK) response.

TPId: SIP_RG_RR_V_014

Status: Mandatory

Ref: 10.3 [1]

Purpose: Ensure that the IUT when a binding already registered, on receipt of a REGISTER request including a Contact header set to an address which is in the bindings list with a Call-ID different from the value stored for that binding, and an expiration time set to zero, deletes that binding and sends a Success (200 OK) response.

- TPId:** SIP_RG_RR_V_015
- Status:** Mandatory
- Ref:** 10.3 [1]
- Purpose:** Ensure that the IUT when a binding already registered, on receipt of a REGISTER request including a Contact header set to an address which is in the bindings list with the same Call-ID as the value stored for that binding, CSeq is greater than the stored CSeq value of that binding, and an expiration time other than zero, sends a Success (200 OK) response.
- TPId:** SIP_RG_RR_V_016
- Status:** Mandatory
- Ref:** 10.3 [1]
- Purpose:** Ensure that the IUT when a binding already registered, on receipt of a REGISTER request including a Contact header set to an address which is in the bindings list with the same Call-ID as the value stored for that binding, CSeq is greater than the stored CSeq value of that binding, and an expiration time equal to zero, deletes that binding and sends a Success (200 OK) response.
- TPId:** SIP_RG_RR_V_017
- Status:** Mandatory
- Ref:** 10.3 [1]
- Purpose:** Ensure that the IUT when a call is currently established, on receipt of a REGISTER request, sends a Success (200 OK) response.
- TPId:** SIP_RG_RR_V_018
- Status:** Recommended
- Ref:** 10.3 [1] item 3 and 22.2 [1]
- Purpose:** Ensure that the IUT on receipt of a REGISTER request not including an Authorization header field, sends an Unauthorized (401 Unauthorized) response, containing a WWW-Authenticate header.
- TPId:** SIP_RG_RR_V_019
- Status:** Recommended
- Ref:** 10.3 [1] item 4
- Purpose:** Ensure that the IUT on receipt of a REGISTER request, but the authenticated user not authorized to modify this address-of-record, sends a Forbidden (403 Forbidden) response.

5.2.2.2 Invalid Behaviour

TPId: SIP_RG_RR_I_001

Status: Mandatory

Ref: 10.3 [1]

Purpose: Ensure that the IUT on receipt of a REGISTER request including a To header from which the extracted address-of-record is not valid for the domain in the Request-URI, sends a Request Failure (404 Not Found) response.

TPId: SIP_RG_RR_I_002

Status: Mandatory

Ref: 10.3 [1] , 19.1.1 [1]

Purpose: Ensure that the IUT on receipt of a REGISTER request including a user name in the SIP URI as the Request-URI, sends a Success (200 OK) response.

TPId: SIP_RG_RR_I_003

Status: Mandatory

Ref: 10.3 [1]

Purpose: Ensure that the IUT on receipt of a REGISTER request including a Contact header set to "*" together with an additional Contact header, sends a Client error (400 Bad Request) response.

TPId: SIP_RG_RR_I_004

Status: Mandatory

Ref: 10.3 [1]

Purpose: Ensure that the IUT on receipt of a REGISTER request including a Contact header set to "*" and an Expires header with an expiration time set to other than zero, sends a Client error (400 Bad Request) response.

5.2.2.3 Inopportune Behaviour

TPId: SIP_RG_RR_O_001

Status: Mandatory

Ref: 10.3 [1]

Purpose: Ensure that the IUT when a binding already registered, on receipt of a REGISTER request including a Contact header set to * and an Expires header set to zero, and Call-ID is the same as the stored Call-ID value and CSeq is equal to the stored CSeq value of that binding, does not remove that binding and sends a Success (200 OK) response.

TPId: SIP_RG_RR_O_002

Status: Mandatory

Ref: 10.3 [1]

Purpose: Ensure that the IUT when a binding already registered, on receipt of a REGISTER request including a Contact header set to an address which is in the bindings list with the same Call-ID as the value stored for that binding, CSeq is equal to the stored CSeq value of that binding, and an expiration time other than zero, sends a Server Failure (500 Server Error) response.

TPId: SIP_RG_RR_O_003

Status: Mandatory

Ref: 10.3 [1]

Purpose: Ensure that the IUT when a binding already registered, on receipt of a REGISTER request including a Contact header set to an address which is in the bindings list with the same Call-ID as the value stored for that binding, CSeq is equal to the stored CSeq value of that binding, and an expiration time equal to zero, does not remove that binding and sends a Server Failure (500 Server Error) response.

5.3 Test Purposes for Call Control

Ref: 1.4.4 [1]

5.3.1 Originating Endpoint

Group Selection: IUT can behave as User Agent client.

5.3.1.1 Call establishment

5.3.1.1.1 Valid Behaviour

TPId: SIP_CC_OE_CE_V_001

Status: Mandatory

Ref: 8.1.1 [1]

Purpose: Ensure that the IUT, to establish a call sends an INVITE request including at least To, From, CSeq, Call-ID, Max-Forwards, Contact and Via headers.

TPId: SIP_CC_OE_CE_V_002

Status: Recommended

Ref: 8.1.1 [1]

Purpose: Ensure that the IUT, to establish a call sends an INVITE request with a Request-URI set to the same URI value of the To header.

TPId: SIP_CC_OE_CE_V_003

Status: Mandatory

Ref: 8.1.1.2 [1]

Purpose: Ensure that the IUT, to establish a call sends an INVITE request including a To header set to an address of the callee and without TAG parameter.

TPId: SIP_CC_OE_CE_V_004

Status: Mandatory

Ref: 8.1.1.3 [1]

Purpose: Ensure that the IUT, to establish a call sends an INVITE request including a From header with a TAG parameter.

TPId: SIP_CC_OE_CE_V_005

Status: Mandatory

Ref: 8.1.1.5 [1]

Purpose: Ensure that the IUT, to establish a call sends an INVITE request including a CSeq header with a method that matches "INVITE".

TPId: SIP_CC_OE_CE_V_006

Status: Recommended

Ref: 8.1.1.6 [1]

Purpose: Ensure that the IUT, to establish a call sends an INVITE request including a Max-Forward header set to 70.

TPId: SIP_CC_OE_CE_V_007

Status: Mandatory

Ref: 8.1.1.7 [1]

Purpose: Ensure that the IUT, to establish a call sends an INVITE request including a Via header with a protocol name set to SIP, a protocol version set to 2.0 and a branch parameter set to a value beginning with "z9hG4bK".

TPId: SIP_CC_OE_CE_V_008

Status: Recommended

Ref: 13.2.1 [1]

Purpose: Ensure that the IUT, to establish a call sends an INVITE request including Allow and Supported headers.

- TPId:** SIP_CC_OE_CE_V_009
- Status:** Mandatory
- Ref:** 8.1.3.2 [1], 13.2.2.1 [1], figure 5 [1]
- Purpose:** Ensure that the IUT when an INVITE client transaction is in the Calling state, on receipt of a Trying (100 Trying) response enters in the Proceeding state.
-
- TPId:** SIP_CC_OE_CE_V_010
- Status:** Mandatory
- Ref:** 8.1.3.2 [1], 13.2.2.11, figure 5 [1]
- Purpose:** Ensure that the IUT when an INVITE client transaction is in the Calling state, on receipt of a Session Progress (183 Session Progress) response enters in the Proceeding state.
-
- TPId:** SIP_CC_OE_CE_V_011
- Status:** Mandatory
- Ref:** 8.1.3.2 [1], 13.2.2.1 [1], figure 5 [1]
- Purpose:** Ensure that the IUT when an INVITE client transaction is in the Calling state, on receipt of a Unknown (199 Unknown) response enters in the Proceeding state.
-
- TPId:** SIP_CC_OE_CE_V_012
- Status:** Mandatory
- Ref:** 8.1.3.2 [1], 13.2.2.1 [1], figure 5 [1]
- Purpose:** Ensure that the IUT when an INVITE client transaction is in the Proceeding state, on receipt of a Trying (100 Trying) response stays in the Proceeding state.
-
- TPId:** SIP_CC_OE_CE_V_013
- Status:** Mandatory
- Ref:** 12.2.1.1 [1], 13.2.2.4 [1], figure 5 [1], 17.1.1.3 [1]
- Purpose:** Ensure that the IUT when an INVITE client transaction is in the Calling state, on receipt of a Success (200 OK) response sends an ACK request.
-
- TPId:** SIP_CC_OE_CE_V_014
- Status:** Mandatory
- Ref:** 12.2.1.1 [1], 13.2.2.4 [1], figure 5 [1], 17.1.1.3 [1]
- Purpose:** Ensure that the IUT when an INVITE client transaction is in the Proceeding state, on receipt of a Success (200 OK) response sends an ACK request.

TPId: SIP_CC_OE_CE_V_015

Status: Recommended

Ref: 8.1.3.3 [1], figure 5 [1]

Purpose: Ensure that the IUT when an INVITE client transaction is in the Proceeding state, on receipt of a Success (200 OK) response with more than one Via header value does not send an ACK request, discards the response.

TPId: SIP_CC_OE_CE_V_016

Status: Mandatory

Ref: 12.2.1.1 [1], 13.2.2.4 [1], figure 5 [1], 17.1.1.3 [1]

Purpose: Ensure that the IUT when an INVITE client transaction is in the Calling state, on receipt of a Success (200 OK) response sends an ACK request with the same CSeq sequence number as in the original INVITE request and the CSeq method field value set to "ACK".

TPId: SIP_CC_OE_CE_V_017

Status: Mandatory

Ref: 12.2.1.1 [1], 13.2.2.4 [1], figure 5 [1], 17.1.1.3 [1]

Purpose: Ensure that the IUT when an INVITE client transaction is in the Calling state, on receipt of a Success (200 OK) response sends an ACK request with the To header set to the same value as in the received final response.

TPId: SIP_CC_OE_CE_V_018

Status: Mandatory

Ref: 12.2.1.1 [1], 13.2.2.4 [1], figure 5 [1], 17.1.1.3 [1]

Purpose: Ensure that the IUT when an INVITE client transaction is in the Calling state, on receipt of a Success (200 OK) response including a To header without TAG sends an ACK request with a To header without TAG.

TPId: SIP_CC_OE_CE_V_019

Status: Mandatory

Ref: 12.2.1.1 [1], 13.2.2.4 [1] figure 5 [1], 17.1.1.2 [1]

Purpose: Ensure that the IUT when an INVITE client transaction is in the Calling state, on receipt of Success (200 OK) responses differing only on the tag in the To header, sends an ACK request with a To header identical to the received one for each received Success (200 OK) responses.

TPId: SIP_CC_OE_CE_V_020

Status: Mandatory

Ref: 12.2.1.1 [1], figure 5 [1], 17.1.1.3 [1]

Purpose: Ensure that the IUT when an INVITE client transaction is in the Calling state, on receipt of a Success (200 OK) response sends an ACK request with the same Call-ID and From headers as in the original INVITE request.

TPId: SIP_CC_OE_CE_V_021

Status: Mandatory

Ref: 12.2.1.1 [1], 13.2.2.4 [1], figure 5 [1]

Purpose: Ensure that the IUT when an INVITE client transaction is in the Calling state, on receipt of a Success (200 OK) response with no Record-Route header set sends an ACK request with the Request-URI set to the Contact URI included in the received final response and with no Route header set.

TPId: SIP_CC_OE_CE_V_022

Status: Mandatory

Ref: 12.2.1.1 [1], 13.2.2.4 [1], figure 5 [1]

Purpose: Ensure that the IUT when an INVITE client transaction is in the Calling state, on receipt of a Success (200 OK) response with a Record-Route header set to a list in which the last element contains lr parameter, sends an ACK request with the Request-URI set to the Contact URI and a Route header set to the list in a reverse order of the Record-Route included in the received final response.

TPId: SIP_CC_OE_CE_V_023

Status: Mandatory

Ref: 12.2.1.1 [1], 13.2.2.4 [1], figure 5 [1]

Purpose: Ensure that the IUT when an INVITE client transaction is in the Calling state, on receipt of a Success (200 OK) response with a Record-Route header set to a list in which the last element does not contain lr parameter, sends an ACK request with the Request-URI set to this element and a Route header set to the remainder list in a reverse order of the received Record-Route appended with the received Contact URI.

TPId: SIP_CC_OE_CE_V_024

Status: Mandatory

Ref: 13.2.2.2 [1] figure 5 [1], 17.1.1.2 [1], 17.1.1.3 [1]

Purpose: Ensure that the IUT when an INVITE client transaction is in the Calling state, on receipt of a Multiple Choices (300 Multiple Choices) response sends an ACK request with the same Call-ID, From headers and Request-URI as in the original INVITE request and the same Tag in the To header as in the Multiple Choices (300 Multiple Choices) response.

- TPId:** SIP_CC_OE_CE_V_025
- Status:** Mandatory
- Ref:** 13.2.2.2 [1] figure 5 [1], 17.1.1.2 [1], 17.1.1.3 [1]
- Purpose:** Ensure that the IUT when an INVITE client transaction is in the Proceeding state, on receipt of a Multiple Choices (300 Multiple Choices) response sends an ACK request with the same Call-ID, From headers and Request-URI as in the original INVITE request and the same Tag in the To header as in the Multiple Choices (300 Multiple Choices) response.
- TPId:** SIP_CC_OE_CE_V_026
- Status:** Mandatory
- Ref:** 13.2.2.2 [1], figure 5 [1], 17.1.1.3 [1]
- Purpose:** Ensure that the IUT when an INVITE client transaction is in the Calling state, on receipt of a Multiple Choices (300 Multiple Choices) response sends an ACK request with a single Via header equal to the top Via header sent in the original INVITE request.
- TPId:** SIP_CC_OE_CE_V_027
- Status:** Mandatory
- Ref:** 13.2.2.2 [1] figure 5 [1], 17.1.1.2 [1], 17.1.1.3 [1]
- Purpose:** Ensure that the IUT when an INVITE client transaction is in the Calling state, on receipt of a Moved Permanently (301 Moved Permanently) response sends an ACK request with the same Call-ID, From headers and Request-URI as in the original INVITE request and the same Tag in the To header as in the Moved Permanently (301 Moved Permanently) response.
- TPId:** SIP_CC_OE_CE_V_028
- Status:** Mandatory
- Ref:** 12.2.1.1 [1], 13.2.2.2 [1] figure 5 [1], 17.1.1.2 [1], 17.1.1.3 [1]
- Purpose:** Ensure that the IUT when an INVITE client transaction is in the Calling state, on receipt of a Moved Temporarily (302 Moved Temporarily) response sends an ACK request with the same Call-ID, From headers and Request-URI as in the original INVITE request and the same Tag in the To header as in the Moved Temporarily (302 Moved Temporarily) response.
- TPId:** SIP_CC_OE_CE_V_029
- Status:** Optional/Recommended
- Ref:** 8.1.3.4 [1], 21.3.4 [1], 13.2.2.2 [1] figure 5 [1], 17.1.1.2 [1], 17.1.1.3 [1]
- Purpose:** Ensure that the IUT when an INVITE client transaction is in the Calling state, on receipt of a Use Proxy (305 Use Proxy) response sends an INVITE request to the proxy given by the Contact header.

TPId: SIP_CC_OE_CE_V_030

Status: Optional/Recommended

Ref: 8.1.3.4 1, figure 5 1

Purpose: Ensure that the IUT when an INVITE client transaction is in the Calling state, on receipt of a Moved Permanently (301 Moved Permanently) response sends a new INVITE request with a Request-URI set with one of URI given in the Contact header of the redirection response.

TPId: SIP_CC_OE_CE_V_031

Status: Optional/Recommended

Ref: 8.1.3.4 [1], figure 5 [1]

Purpose: Ensure that the IUT when an INVITE client transaction is in the Calling state, on receipt of a Moved Permanently (301 Moved Permanently) response sends a new INVITE request with a new branch ID in the top Via header.

TPId: SIP_CC_OE_CE_V_032

Status: Mandatory

Ref: 13.2.2.3 [1] figure 5 [1], 17.1.1.2 [1], 17.1.1.3 [1]

Purpose: Ensure that the IUT when an INVITE client transaction is in the Calling state, on receipt of a Not Found (404 Not Found) response sends an ACK request with the same Call-ID, From headers and Request-URI as in the original INVITE request and the same Tag in the To header as in this response.

TPId: SIP_CC_OE_CE_V_033

Status: Mandatory

Ref: 13.2.2.3 [1] figure 5 [1], 17.1.1.2 [1], 17.1.1.3 [1]

Purpose: Ensure that the IUT when an INVITE client transaction is in the Proceeding state, on receipt of a Not Found (404 Not Found) response sends an ACK request with the same Call-ID, From headers and Request-URI as in the original INVITE request and the same Tag in the To header as in this response.

TPId: SIP_CC_OE_CE_V_034

Status: Mandatory

Ref: 13.2.2.3 [1] figure 5 [1], 17.1.1.2 [1], 17.1.1.3 [1]

Purpose: Ensure that the IUT when an INVITE client transaction is in the Calling state, on receipt of a Gone (410 Gone) response sends an ACK request with the same Call-ID, From headers and Request-URI as in the original INVITE request and the same Tag in the To header as in this response.

- TPId:** SIP_CC_OE_CE_V_035
- Status:** Mandatory
- Ref:** 13.2.2.3 [1] figure 5 [1], 17.1.1.2 [1], 17.1.1.3 [1]
- Purpose:** Ensure that the IUT when an INVITE client transaction is in the Calling state, on receipt of a Temporarily Unavailable (480 Temporarily Unavailable) response sends an ACK request with the same Call-ID, From headers and Request-URI as in the original INVITE request and the same Tag in the To header as in this response.
-
- TPId:** SIP_CC_OE_CE_V_036
- Status:** Mandatory
- Ref:** 13.2.2.3 [1] figure 5 [1], 17.1.1.2 [1], 17.1.1.3 [1]
- Purpose:** Ensure that the IUT when an INVITE client transaction is in the Calling state, on receipt of a Busy Here (486 Busy Here) response sends an ACK request with the same Call-ID, From headers and Request-URI as in the original INVITE request and the same Tag in the To header as in this response.
-
- TPId:** SIP_CC_OE_CE_V_037
- Status:** Mandatory
- Ref:** 13.2.2.3 [1] figure 5 [1], 17.1.1.2 [1], 17.1.1.3 [1]
- Purpose:** Ensure that the IUT when an INVITE client transaction is in the Calling state, on receipt of a Server Internal Error (500 Server Internal Error) response sends an ACK request with the same Call-ID, From headers and Request-URI as in the original INVITE request and the same Tag in the To header as in this response.
-
- TPId:** SIP_CC_OE_CE_V_038
- Status:** Mandatory
- Ref:** 13.2.2.3 [1] figure 5 [1], 17.1.1.2 [1], 17.1.1.3 [1]
- Purpose:** Ensure that the IUT when an INVITE client transaction is in the Calling state, on receipt of a Busy Everywhere (600 Busy Everywhere) and a Server Internal Error (500 Server Internal Error) responses with different branch parameter value on the top Via header sends only one ACK request.
-
- TPId:** SIP_CC_OE_CE_V_039
- Status:** Mandatory
- Ref:** 13.2.2.3 [1] figure 5 [1], 17.1.1.2 [1], 17.1.1.3 [1]
- Purpose:** Ensure that the IUT when an INVITE client transaction is in the Calling state, on receipt of a Decline (603 Decline) response sends an ACK request with the same Call-ID, From headers and Request-URI as in the original INVITE request and the same Tag in the To header as in this response.

- TPId:** SIP_CC_OE_CE_V_040
- Status:** Mandatory
- Ref:** 13.2.2.3 [1] figure 5 [1], 17.1.1.2 [1], 17.1.1.3 [1]
- Purpose:** Ensure that the IUT having already received a non 2XX final response to its INVITE request, on receipt of a Decline (603 Decline) response, with the same Via branch parameter and CSeq header method as in the INVITE request, sends an ACK message.
-
- TPId:** SIP_CC_OE_CE_V_041
- Status:** Mandatory
- Ref:** 17 [1], 13.2.2.3 [1] figure 5 [1], 17.1.1.2 [1], 17.1.1.3 [1]
- Purpose:** Ensure that the IUT having already received a 2XX final response to its INVITE request, on receipt of a Success (200 OK) response, with a different Record-Route as in previous response, but with the same Via branch parameter and CSeq header method as in the INVITE request, sends an ACK request with a Route header set according to this new Record-Route.
-
- TPId:** SIP_CC_OE_CE_V_042
- Status:** Mandatory
- Ref:** 8.1.3.2 1, 13.2.2.31, figure 5 1, 17.1.1.2 1, 17.1.1.3 1
- Purpose:** Ensure that the IUT when an INVITE client transaction is in the Calling state, on receipt of a Unknown (699 Unknown) response sends an ACK request with the same Call-ID, From headers and Request-URI as in the original INVITE request and the same Tag in the To header as in this response.
-
- TPId:** SIP_CC_OE_CE_V_043
- Status:** Optional
- Ref:** 21.3.3 [1], 12.2.1 [1], 13.2.2.2 [1] figure 5 [1], 17.1.1.2 [1], 17.1.1.3 [1]
- Purpose:** Ensure that the IUT having sent an INVITE to the location get from the redirect server, on receipt of a Success (200 OK) response sends an ACK request.
-
- TPId:** SIP_CC_OE_CE_V_044
- Status:** Mandatory
- Ref:** 13.2.1 [1]
- Purpose:** Ensure that the IUT while is establishing a call, sends a unique session description either in the INVITE request or in the ACK request to answer the initial offers given then in the final 2XX response.

TPId: SIP_CC_OE_CE_V_045
Status: Recommended
Ref: 20.14 [1], 13.2.1 [1]
Purpose: Ensure that the IUT while is establishing a call, sends a Content-Length header set to the size of the body in the message that contains the session description.

TPId: SIP_CC_OE_CE_V_046
Status: Mandatory
Ref: 20.15 [1], 13.2.1 [1]
Purpose: Ensure that the IUT while is establishing a call, sends a Content-Type header in the message that contains the session description.

TPId: SIP_CC_OE_CE_V_047
Status: Mandatory
Ref: 7.4. 1, 13.2.1 1
Purpose: Ensure that the IUT while is establishing a call, sends a Content-Encoding header only in the message that contains the session description.

TPId: SIP_CC_OE_CE_V_048
Status: Mandatory
Ref: 13.2.1 [1]
Purpose: Ensure that the IUT while is establishing a call on receipt of in 2XX a not acceptable session description, sends an ACK request immediately followed by a BYE request.

5.3.1.1.2 Timers

TPId: SIP_CC_OE_CE_TI_001
Status: Mandatory
Ref: Annex A [1], 17.1.1.1 [1]
Purpose: If an unreliable transport (UDP) is used, ensure that the IUT, when an INVITE client transaction is in the Calling state repeats its INVITE request on the timeout condition of timer A set with a value of T1.

TPId: SIP_CC_OE_CE_TI_002
Status: Recommended
Ref: Annex A [1], 17.1.1.1 [1]
Purpose: If a reliable transport (TCP) is used, ensure that the IUT, when an INVITE client transaction is in the Calling state does not repeat its INVITE request on the timeout condition of timer A set with a value of T1.

- TPId:** SIP_CC_OE_CE_TI_003
- Status:** Mandatory
- Ref:** Annex A [1], 17.1.1.1 [1]
- Purpose:** If an unreliable transport (UDP) is used, ensure that the IUT, when an INVITE client transaction is in the Calling state having already repeated its INVITE wait for a timer A set with a value of $2 * T1$ before sending it again.
-
- TPId:** SIP_CC_OE_CE_TI_004
- Status:** Mandatory
- Ref:** Annex A [1], 17.1.1.1 [1]
- Purpose:** If an unreliable transport (UDP) is used, ensure that the IUT, when an INVITE client transaction is in the Calling state retransmits its INVITE request with intervals that double after each transmission.
-
- TPId:** SIP_CC_OE_CE_TI_005
- Status:** Mandatory
- Ref:** Annex A [1], 17.1.1.1 [1]
- Purpose:** Ensure that the IUT, when an INVITE client transaction is in the Calling state, when timer B set to a value of $64 * T1$ expires, does not send an ACK.
-
- TPId:** SIP_CC_OE_CE_TI_006
- Status:** Recommended
- Ref:** Annex A [1], 17.1.1.1 [1]
- Purpose:** Ensure that the IUT, when an INVITE client transaction is in the Calling state, when timer B set to a value of $64 * T1$ expires, considers the transaction terminated.
-
- TPId:** SIP_CC_OE_CE_TI_007
- Status:** Recommended
- Ref:** Annex A [1], 17.1.1.1 [1]
- Purpose:** Ensure that the IUT, when an INVITE client transaction is in the Proceeding state, does not repeat its INVITE request.
-
- TPId:** SIP_CC_OE_CE_TI_008
- Status:** Recommended
- Ref:** Annex A [1], 17.1.1.1 [1]
- Purpose:** If an unreliable transport is used, ensure that the IUT, when an INVITE client transaction is in the Completed state, on receipt of final responses that matches the transaction, still answer with an ACK request until timer D set to at least 32 second expires.

TPId: SIP_CC_OE_CE_TI_009
Status: Recommended
Ref: Annex A [1], 17.1.1.1 [1]
Purpose: If a reliable transport is used, ensure that the IUT, when an INVITE client transaction is in the Completed state, on receipt of a final response that matches the transaction, does not repeats its ACK request.

TPId: SIP_CC_OE_CE_TI_010
Status: Recommended
Ref: Annex A [1], 17.1.1.1 [1]
Purpose: If an unreliable transport is used, ensure that the IUT, when an INVITE client transaction is in the Completed state, on receipt of new final responses with different Via branch parameter value, does not repeat its ACK request until timer D set to at least 32 second expires.

TPId: SIP_CC_OE_CE_TI_011
Status: Mandatory
Ref: Annex A 1, 13.2.2.4 1
Purpose: Ensure that the IUT, when an INVITE client transaction has been in the Terminated state, on receipt of a retransmitted Success (200 OK) responses sends an ACK request until 64*T1 duration expires.

TPId: SIP_CC_OE_CE_TI_012
Status: Mandatory
Ref: Annex A [1], 13.2.2.4 [1]
Purpose: Ensure that the IUT, when an INVITE client transaction has been in the Terminated state, after 64*T1 duration expires, on receipt of a retransmitted Success (200 OK) responses does not send an ACK request.

5.3.1.2 Call release

5.3.1.2.1 Valid Behaviour

TPId: SIP_CC_OE_CR_V_001
Status: Mandatory
Ref: 12.2.1.1 [1], 15 [1]
Purpose: Ensure that the IUT, once a dialog has been established, to release it sends a BYE request with a To header set to the same value as in the last received final response.

TPId: SIP_CC_OE_CR_V_002

Status: Mandatory

Ref: 12.2.1.1 [1], 15 [1]

Purpose: Ensure that the IUT, once a dialog has been established with a final response in which the TAG in the To header was omitted, to release it sends a BYE request with an identical To header without TAG value.

TPId: SIP_CC_OE_CR_V_003

Status: Mandatory

Ref: 12.2.1.1 [1], 15 [1]

Purpose: Ensure that the IUT, once a dialog has been established, to release it sends a BYE request with the same Call-ID, From headers as in the original INVITE message.

TPId: SIP_CC_OE_CR_V_004

Status: Mandatory

Ref: 12.2.1.1 [1]

Purpose: Ensure that the IUT, once a dialog has been established, to release it sends a BYE request with an incremented of one CSeq value, a method field in the CSeq header set to "BYE".

TPId: SIP_CC_OE_CR_V_005

Status: Mandatory

Ref: 12.2.1.1 [1], 15 [1]

Purpose: Ensure that the IUT, once a dialog has been established with a Success (200 OK) response including no Record-Route header set, to release it sends a BYE request with the Request-URI set to the Contact URI included in the received final response and with no Route header set.

TPId: SIP_CC_OE_CR_V_006

Status: Mandatory

Ref: 12.2.1.1 [1], 15 [1]

Purpose: Ensure that the IUT, once a dialog has been established with a Success (200 OK) response including a Record-Route header set to a list in which the last element contains lr parameter, to release the call, sends a BYE request with the Request-URI set to the Contact URI and a Route header set to the list in a reverse order of the Record-Route included in the received final response.

- TPId:** SIP_CC_OE_CR_V_007
- Status:** Mandatory
- Ref:** 12.2.1.11, 151
- Purpose:** Ensure that the IUT, once a dialog has been established with a Success (200 OK) response including a Record-Route header set to a list in which the last element does not contain lr parameter, to release the call, sends an BYE request with the Request-URI set to this element and a Route header set to the remainder list in a reverse order of the received Record-Route appended with the received Contact URI.
-
- TPId:** SIP_CC_OE_CR_V_008
- Status:** Mandatory
- Ref:** 12.2.1.1 [1], 15.1.1 [1]
- Purpose:** Ensure that the IUT, once a dialog has been established, having sent a BYE request, on receipt of a Success (200 OK) response considers the session and the dialog terminated.
-
- TPId:** SIP_CC_OE_CR_V_009
- Status:** Mandatory
- Ref:** 12.2.1.1 [1], 15.1.1 [1]
- Purpose:** Ensure that the IUT, once a dialog has been established, having sent a BYE request, on receipt of a Call Leg/Transaction Does Not Exist (481 Call Leg/Transaction Does Not Exist) considers the session and the dialog terminated.
-
- TPId:** SIP_CC_OE_CR_V_010
- Status:** Mandatory
- Ref:** 15 [1], 9.1 [1], figure 5 [1]
- Purpose:** Ensure that the IUT having received a Trying (100 Trying) response to its INVITE request, to give up the call, sends a CANCEL request.
-
- TPId:** SIP_CC_OE_CR_V_011
- Status:** Mandatory
- Ref:** 15 [1], 9.1 [1], figure 5 [1]
- Purpose:** Ensure that the IUT having received a Trying (100 Trying) response to its INVITE request, to give up the call, sends a CANCEL request with the same Request-URI, Call-ID, From, To headers as in the original INVITE message.

TPId: SIP_CC_OE_CR_V_012
Status: Mandatory
Ref: 15 [1], 9 [1], figure 5 [1]
Purpose: Ensure that the IUT having received a Trying (100 Trying) response to its INVITE request, sends a CANCEL request with the same numeric part of CSeq as in the original INVITE message and with a method field in the CSeq header set to "CANCEL".

TPId: SIP_CC_OE_CR_V_013
Status: Mandatory
Ref: 15 [1], 9.1 [1], figure 5 [1]
Purpose: Ensure that the IUT having received a Trying (100 Trying) response to its INVITE request, sends a CANCEL request with a single Via header value matching the top Via value of the Via header of the original INVITE message.

TPId: SIP_CC_OE_CR_V_014
Status: Mandatory
Ref: 15 1, 9.1 1, figure 5 1
Purpose: Ensure that the IUT having received a Trying (100 Trying) response to its INVITE request, to give up the call, sends a CANCEL request without Require or Proxy-Require header.

TPId: SIP_CC_OE_CR_V_015
Status: Mandatory
Ref: 15 [1], 9.1 [1], figure 5 [1]
Purpose: Ensure that the IUT having received a Trying (100 Trying) response to its INVITE request, to give up the call having sent a CANCEL request, on receipt of a 2XX response to the original INVITE sends an ACK request.

5.3.1.2.2 Invalid Behaviour

TPId: SIP_CC_OE_CR_I_001
Status: Mandatory
Ref: 9 [1], 16.10 [1]
Purpose: Ensure that the IUT, once a dialog has been established, on receipt of a CANCEL request followed by a BYE request, sends a Success (200 OK) response to the BYE request.

5.3.1.2.3 Timers

TPId: SIP_CC_OE_CR_TI_001
Status: Mandatory
Ref: Annex A [1], 17.1.2.2 [1]
Purpose: If an unreliable transport is used, ensure that the IUT, having sent a BYE request on an established dialog, repeats its request after timer E set to T1 value expires.

TPId: SIP_CC_OE_CR_TI_002
Status: Mandatory
Ref: Annex A [1], 17.1.3 [1]
Purpose: If an unreliable transport is used, ensure that the IUT, having sent twice times a BYE request on an established dialog, repeats its request after timer E set to the $\text{MIN}(2*T1, T2)$ value expires.

TPId: SIP_CC_OE_CR_TI_003
Status: Mandatory
Ref: Annex A [1], 17.1.3 [1]
Purpose: If an unreliable transport is used, ensure that the IUT, having sent three times a BYE request on an established dialog, repeats its request after timer E set to the $\text{MIN}(4*T1, T2)$ value expires.

TPId: SIP_CC_OE_CR_TI_004
Status: Recommended
Ref: Annex A [1], 17.1.3 [1]
Purpose: If an unreliable transport is used, ensure that the IUT does not repeat a BYE request on an established dialog, after timer F set to $64*T1$ expires.

TPId: SIP_CC_OE_CR_TI_005
Status: Mandatory
Ref: Annex A , 17.1.3 [1]
Purpose: Ensure that the IUT, when a BYE client transaction is in the Proceeding state, repeats its BYE request after timer E set to T1 value expires.

TPId: SIP_CC_OE_CR_TI_006
Status: Mandatory
Ref: Annex A [1], 17.1.3 [1]
Purpose: Ensure that the IUT, when a BYE client transaction is in the Proceeding state and BYE request have been already repeated in this state, repeats its BYE request after timer E set to T2 value expires.

TPId: SIP_CC_OE_CR_TI_007
Status: Mandatory
Ref: Annex A [1], 17.1.3 [1]
Purpose: Ensure that the IUT, when a BYE client transaction is in the Proceeding state, does not repeat a BYE request on an established dialog, after timer F set to $64*T1$ expires.

TPId: SIP_CC_OE_CR_TI_008
Status: Recommended
Ref: Annex A [1], 17.1.3 [1], 9.1 [1]
Purpose: Ensure that the IUT, when a BYE client transaction is in the Trying state, considers the transaction terminated after 64*T1 duration expires without receiving any final response.

5.3.1.3 Session modification

5.3.1.3.1 Valid Behaviour

TPId: SIP_CC_OE_SM_V_001
Status: Mandatory
Ref: 14.2 [1]
Purpose: Ensure that the IUT, having sent an INVITE, on receipt of a re-INVITE on this dialog, sends a Request Pending (491 Request Pending) response.

TPId: SIP_CC_OE_SM_V_002
Status: Mandatory
Ref: 14.2 [1]
Purpose: Ensure that the IUT when an INVITE client transaction is in the Proceeding state, on receipt of a re-INVITE on this dialog, sends a Request Pending (491 Request Pending) response.

5.3.2 Terminating Endpoint

GroupSelection: IUT can behave as User Agent server.

5.3.2.1 Call establishment

5.3.2.1.1 Valid Behaviour

TPId: SIP_CC_TE_CE_V_001
Status: Mandatory
Ref: 8.2 [1], 13.3.1.1 [1], 8 [1]
Purpose: Ensure that the IUT on receipt of an INVITE request, sends a Success (200 OK) or a provisional (101-199) response.

TPId: SIP_CC_TE_CE_V_002
Status: Recommended
Ref: 8.2.2.1 [1]
Purpose: Ensure that the IUT on receipt of an INVITE request with a Request-URI set with a scheme that it does not support, sends a Unsupported URI scheme (416 Unsupported URI scheme) response.

- TPId:** SIP_CC_TE_CE_V_003
- Status:** Recommended
- Ref:** 8.2.2.1 [1]
- Purpose:** Ensure that the IUT on receipt of an INVITE request with a Request-URI set with an address that it does not accept sends a Not Found (404 Not Found) response.
-
- TPId:** SIP_CC_TE_CE_V_004
- Status:** Mandatory
- Ref:** 8.2.6.1 [1], 8 [1]
- Purpose:** Ensure that the IUT on receipt of an INVITE request with a Timestamp header, when it answers with a provisional response Trying (100 Trying), set a Timestamp header with an increased value of the received Timestamp in its response.
-
- TPId:** SIP_CC_TE_CE_V_005
- Status:** Recommended
- Ref:** 13.3.1 [1]
- Purpose:** Ensure that the IUT on receipt of an INVITE request including an Expires header set to 0, sends a Request Terminated (487 Request Terminated) response.
-
- TPId:** SIP_CC_TE_CE_V_006
- Status:** Mandatory
- Ref:** 13.2.1 [1], 13.3.1 [1]
- Purpose:** Ensure that the IUT on receipt of an INVITE request including no message body, includes in its first 2xx response an initial offer session description.
-
- TPId:** SIP_CC_TE_CE_V_007
- Status:** Mandatory
- Ref:** 13.2.1 [1], 13.3.1 [1]
- Purpose:** Ensure that the IUT on receipt of an INVITE request including an initial offer session description in its message body, includes the answer in its first 2xx response a session description.
-
- TPId:** SIP_CC_TE_CE_V_008
- Status:** Mandatory
- Ref:** 13.2.1 [1], 13.3.1 [1]
- Purpose:** Ensure that the IUT on receipt of an INVITE request including a message body with a Content-Disposition header not set to session value, includes in its first 2xx response an initial offer session description.

- TPId:** SIP_CC_TE_CE_V_009
- Status:** Mandatory
- Ref:** 13.2.1 [1], 13.3.1 [1], 20.11 [1]
- Purpose:** Ensure that the IUT on receipt of an INVITE request including a Content-Language header value that it cannot understand and a Content-Disposition header including a handling set to "optional", includes in its first 2xx response an initial offer session description.
-
- TPId:** SIP_CC_TE_CE_V_010
- Status:** Recommended
- Ref:** 8.2.3 [1], 13.2.1 [1], 13.3.1 [1], 20.11 [1]
- Purpose:** Ensure that the IUT on receipt of an INVITE request including a Content-Language header value that it cannot understand, a Content-Disposition header including a handling empty sends an Unsupported Media Type (415 Unsupported Media Type) response with an Accept header that lists the types of all bodies it understands.
-
- TPId:** SIP_CC_TE_CE_V_011
- Status:** Mandatory
- Ref:** 8.2.3 [1], 21.4.13 [1], 13.2.1 [1], 13.3.1 [1], 20.11 [1]
- Purpose:** Ensure that the IUT on receipt of an INVITE request including a Content-Language header value that it cannot understand, a Content-Disposition with a handling set to "required" and a disposition-types set to session, sends an Unsupported Media Type (415 Unsupported Media Type) response with an Accept header that lists the types of all bodies it understands.
-
- TPId:** SIP_CC_TE_CE_V_012
- Status:** Mandatory
- Ref:** 8.2.3 [1], 21.4.13 [1], 13.2.1 [1], 13.3.1 [1], 20.11 [1]
- Purpose:** Ensure that the IUT on receipt of an INVITE request including a Content-Encoding header set to content-coding values that it does not support, sends an Unsupported Media Type (415 Unsupported Media Type) response with an Accept-Encoding header that list the types of coding that it understands.
-
- TPId:** SIP_CC_TE_CE_V_013
- Status:** Recommended
- Ref:** 13.3.1.3 [1], 21.4.13 [1]
- Purpose:** Ensure that the IUT on receipt of an INVITE request including a session description that it can understand but it cannot accept, a Content-Disposition with a handling set to "required" and a disposition-types set to session, sends a Not Acceptable Here (488 Not Acceptable Here) response including a Warning header.

TPId: SIP_CC_TE_CE_V_014

Status: Mandatory

Ref: 8.2.6.2 [1]

Purpose: Ensure that the IUT on receipt of an INVITE request, sends a Success (200 OK) or a provisional (101-199) response including the headers From, Call-ID, CSeq and Via headers copy from the INVITE request.

TPId: SIP_CC_TE_CE_V_015

Status: Mandatory

Ref: 8.2.6.2 [1]

Purpose: Ensure that the IUT on receipt of an INVITE request with no TAG set on the To header, sends a Success (200 OK) or a provisional (101-199) response including the same URI and an additional TAG for the To header.

TPId: SIP_CC_TE_CE_V_016

Status: Mandatory

Ref: 8.2.6.2 [1]

Purpose: Ensure that the IUT on receipt of an INVITE request with a TAG set on the To header, sends a Success (200 OK) or a provisional (101-199) response including the same URI and the same TAG for the To header.

TPId: SIP_CC_TE_CE_V_017

Status: Mandatory

Ref: 12.1.1 [1]

Purpose: Ensure that the IUT on receipt of an INVITE request, sends a Success (200 OK) or a provisional (101-199) response including a single Contact header.

TPId: SIP_CC_TE_CE_V_018

Status: Mandatory

Ref: 12.1.1 [1]

Purpose: Ensure that the IUT on receipt of an INVITE request including a Record-Route header, sends a Success (200 OK) or a provisional (101-199) response including a Record-Route header copy from the INVITE request, in the same order.

TPId: SIP_CC_TE_CE_V_019

Status: Mandatory

Ref: 12.1.1 [1]

Purpose: Ensure that the IUT on receipt of an INVITE request including a Record-Route header with parameters that it does not understand, sends a Success (200 OK) or a provisional (101-199) response including a Record-Route header copy from the INVITE request, with the unknown parameters.

TPId: SIP_CC_TE_CE_V_020

Status: Mandatory

Ref: 12.1.1 [1]

Purpose: Ensure that the IUT on receipt of an INVITE request including From header without tag, sends a Success (200 OK) or a provisional (101-199) response including a From header without tag.

TPId: SIP_CC_TE_CE_V_021

Status: Recommended

Ref: 13.3.1.4 [1]

Purpose: Ensure that the IUT having received an INVITE request, sends a Success (200 OK) including an Allow and a Supported headers.

TPId: SIP_CC_TE_CE_V_022

Status: Mandatory

Ref: 17.2.1 [1], 17.2.3 [1]

Purpose: Ensure that the IUT when a server INVITE transaction is in the Proceeding state, on receipt of an INVITE request, including a Via header set with the same branch parameter and sent-by value in the topmost list value, repeats its last response.

TPId: SIP_CC_TE_CE_V_023

Status: Mandatory

Ref: 17.2.1 [1], 17.2.3 [1]

Purpose: Ensure that the IUT when a server INVITE transaction is in the Proceeding state, on receipt of an INVITE request, including a Via header set with no branch parameter but with the Request-URI, To tag, From tag, Call-ID, CSeq and top Via identical as in the first INVITE request, repeats its last response.

TPId: SIP_CC_TE_CE_V_024

Status: Mandatory

Ref: 17.2.1 [1], 17.2.3 [1]

Purpose: Ensure that the IUT when a server INVITE transaction is in the Proceeding state, on receipt of an INVITE request, including a Via header set with a different branch parameter without the magic cookie "z9hG4bK" but with the Request-URI, To tag, From tag, Call-ID, CSeq and top Via identical as in the first INVITE request, repeats its last response.

TPId: SIP_CC_TE_CE_V_025

Status: Recommended

Ref: 17.2.1 [1], 17.2.3 [1]

Purpose: Ensure that the IUT when a server INVITE transaction is in the Completed state, on receipt of an INVITE request, including a Via header set with the same branch parameter and sent-by value in the topmost list value, repeats its last response.

TPId: SIP_CC_TE_CE_V_026

Status: Recommended

Ref: 17.2.1 [1], 17.2.3 [1]

Purpose: Ensure that the IUT when a server INVITE transaction is in the Completed state, on receipt of an INVITE request, including a Via header set with no branch parameter but with the Request-URI, To tag, From tag, Call-ID, CSeq and top Via identical as in the first INVITE request, repeats its last response.

TPId: SIP_CC_TE_CE_V_027

Status: Recommended

Ref: 17.2.1 [1], 17.2.3 [1]

Purpose: Ensure that the IUT when a server INVITE transaction is in the Completed state, on receipt of an INVITE request, including a Via header set with a different branch parameter without the magic cookie "z9hG4bK" but with the Request-URI, To tag, From tag, Call-ID, CSeq and top Via identical as in the first INVITE request, repeats its last response.

TPId: SIP_CC_TE_CE_V_028

Status: Recommended

Ref: 8.2.2.2 [1], 17.2.1 [1], 17.2.3 [1]

Purpose: Ensure that the IUT when a server INVITE transaction is in the Proceeding state, on receipt of an INVITE request, including a Via header set with a different branch parameter starting with the magic cookie "z9hG4bK" but with the Request-URI, To tag, From tag, Call-ID and CSeq identical as in the first INVITE request, sends a Loop Detected (482 Loop Detected) response.

TPId: SIP_CC_TE_CE_V_029

Status: Recommended

Ref: 8.2.2.2 [1], 17.2.1 [1], 17.2.3 [1]

Purpose: Ensure that the IUT when a server INVITE transaction is in the Proceeding state, on receipt of an INVITE request, including a Via header set to an identical branch parameter starting with the magic cookie "z9hG4bK" and a different sent-by value, but with the Request-URI, To tag, From tag, Call-ID and CSeq identical as in the first INVITE request, sends a Loop Detected (482 Loop Detected) response.

TPId: SIP_CC_TE_CE_V_030

Status: Recommended

Ref: 8.2.2.2 [1], 17.2.1 [1], 17.2.3 [1]

Purpose: Ensure that the IUT when a server INVITE transaction is in the Proceeding state, on receipt of an INVITE request, including a top Via header set to a different value but with the Request-URI, To tag, From tag, Call-ID and CSeq identical as in the first INVITE request, sends a Loop Detected (482 Loop Detected) response.

TPId: SIP_CC_TE_CE_V_031

Status: Mandatory

Ref: 8.2.2.3 [1]

Purpose: Ensure that the IUT on receipt of an INVITE request with a Require header set to an option value that the IUT does not support, sends a Bad Extension (420 Bad Extension) response including those options in the Unsupported header.

TPId: SIP_CC_TE_CE_V_032

Status: Mandatory

Ref: 17.2.3.1 [1], 13.3.1.4 [1], figure 7 [1]

Purpose: Ensure that the IUT when a server INVITE transaction is in the Proceeding state, after sending a 4XX response, enters in the Completed state.

TPId: SIP_CC_TE_CE_V_033

Status: Mandatory

Ref: 17.2.3.1 [1], 13.3.1.4 [1], figure 7 [1]

Purpose: Ensure that the IUT when a server INVITE transaction is in the Completed state, on receipt of an ACK request, enters in the Confirmed transaction state.

5.3.2.1.2 Invalid Behaviour

TPId: SIP_CC_TE_CE_I_001

Status: Mandatory

Ref: 17.2.3 [1], 8.2.2.3 [1], figure 7 [1]

Purpose: Ensure that the IUT when a server INVITE transaction is in the Completed state, on receipt of an ACK request including a Proxy-Require header set with an option-tag that it does not support, enters in the Confirmed transaction state.

TPId: SIP_CC_TE_CE_I_002

Status: Mandatory

Ref: 17.2.3 [1], 8.2.2.3 [1], figure 7 [1]

Purpose: Ensure that the IUT when a server INVITE transaction is in the Completed state, on receipt of an ACK request including a Require header set with an option-tag that it does not support, enters in the Confirmed transaction state.

5.3.2.1.3 Timers

TPId: SIP_CC_TE_CE_TI_001

Status: Mandatory

Ref: Annex A [1], 17.2.1 [1]

Purpose: If an unreliable transport is used, ensure that the IUT, when an INVITE server transaction is in the Completed state repeats its response on the timeout condition of timer G set with a value of T1.

TPId: SIP_CC_TE_CE_TI_002

Status: Mandatory

Ref: Annex A [1], 17.2.1 [1]

Purpose: If a reliable transport (TCP) is used, ensure that the IUT, when an INVITE server transaction is in the Completed state does not repeat its response on the timeout condition of timer G set with a value of T1.

TPId: SIP_CC_TE_CE_TI_003

Status: Mandatory

Ref: Annex A [1], 17.2.1 [1]

Purpose: If an unreliable transport is used, ensure that the IUT, when an INVITE server transaction is in the Completed state and having already sent twice times its response, repeats it after timer G set $\text{MIN}(2*T1, T2)$ value expires.

- TPId:** SIP_CC_TE_CE_TI_004
- Status:** Mandatory
- Ref:** Annex A [1], 17.2.1 [1]
- Purpose:** If an unreliable transport is used, ensure that the IUT, when an INVITE server transaction is in the Completed state and having already sent three times its response, repeats it after timer G set the $\text{MIN}(4*T1, T2)$ value expires.
-
- TPId:** SIP_CC_TE_CE_TI_005
- Status:** Mandatory
- Ref:** Annex A [1], 17.2.1 [1]
- Purpose:** Ensure that the IUT, when an INVITE server transaction is in the Completed state and, enters in the Terminated state after timer H set to $64*T1$ value expires.
-
- TPId:** SIP_CC_TE_CE_TI_006
- Status:** Mandatory
- Ref:** Annex A [1], 17.2.1 [1]
- Purpose:** If an unreliable transport is used, ensure that the IUT, when an INVITE server transaction is in the Completed state and, does not repeats its response after timer H set to $64*T1$ value expires.
-
- TPId:** SIP_CC_TE_CE_TI_007
- Status:** Mandatory
- Ref:** Annex A [1], 17.2.1 [1]
- Purpose:** If an unreliable transport is used, ensure that the IUT, when an INVITE server transaction is in the Confirmed state, enters in the Terminated state after timer I set to T4 value expires.
-
- TPId:** SIP_CC_TE_CE_TI_008
- Status:** Mandatory
- Ref:** Annex A [1], 17.2.1 [1]
- Purpose:** If a reliable transport is used, ensure that the IUT, when an INVITE server transaction is in the Confirmed state, enters immediately in the Terminated state.
-
- TPId:** SIP_CC_TE_CE_TI_009
- Status:** Mandatory
- Ref:** Annex A [1], 13.3.1.4 [1]
- Purpose:** Ensure that the IUT, when it has answered to an INVITE request with 2XX response, repeats it after T1 duration expires without receiving an ACK request.

TPId: SIP_CC_TE_CE_TI_010
Status: Mandatory
Ref: Annex A [1], 13.3.1.4 [1]
Purpose: Ensure that the IUT, when it has already answered twice times to an INVITE request with a 2XX response, repeats it after 2*T1 duration expires without receiving an ACK request.

TPId: SIP_CC_TE_CE_TI_011
Status: Mandatory
Ref: Annex A [1], 13.3.1.4 [1]
Purpose: Ensure that the IUT, does not repeat its 2XX response to an INVITE request after T2 duration expires without receiving an ACK request.

TPId: SIP_CC_TE_CE_TI_012
Status: Recommended
Ref: Annex A [1], 13.3.1.4 [1]
Purpose: Ensure that the IUT, when it has receive no ACK to its 2XX responses during a duration of 64*T1 seconds, sends a BYE request.

5.3.2.2 Call release

5.3.2.2.1 Valid Behaviour

TPId: SIP_CC_TE_CR_V_001
Status: Mandatory
Ref: 15 [1]
Purpose: Ensure that the IUT while a session has been established, on receipt of a BYE request sends a Success (200 OK) response.

TPId: SIP_CC_TE_CR_V_002
Status: Mandatory
Ref: 15 [1], 12 [1]
Purpose: Ensure that the IUT while the dialog is in an early stage, on receipt of a BYE request sends a response.

TPId: SIP_CC_TE_CR_V_003
Status: Mandatory
Ref: 15 [1], 12 [1]
Purpose: Ensure that the IUT while the dialog is in a confirmed stage, on receipt of a BYE request sends a Success (200 OK) response.

TPId: SIP_CC_TE_CR_V_004

Status: Mandatory

Ref: 8.2.2 [1], 15.1.2 [1]

Purpose: Ensure that the IUT once a dialog has been established, on receipt of a BYE request including a header that it does not understand sends a Success (200 OK) response.

TPId: SIP_CC_TE_CR_V_005

Status: Mandatory

Ref: 8.2.2 [1], 15.1.2 [1]

Purpose: Ensure that the IUT, once a dialog has been established, on receipt of a BYE request including a Require header set with an option-tag that it does not support, sends a Bad Extension (420 Bad Extension) response including a Unsupported set with this option-tag.

TPId: SIP_CC_TE_CR_V_006

Status: Mandatory

Ref: 8.2.6.2 [1], 15.1.2 [1]

Purpose: Ensure that the IUT, once a dialog has been established, on receipt of a BYE request, sends a Success (200 OK) response with From, Call-ID, CSeq and Via headers set to the same value as in the request.

TPId: SIP_CC_TE_CR_V_007

Status: Recommended

Ref: 15.1.2 [1]

Purpose: Ensure that the IUT, while no dialog has been established, on receipt of a BYE request, sends a Call/Transaction does not exist (481 Call/Transaction does not exist).

TPId: SIP_CC_TE_CR_V_008

Status: Recommended

Ref: 15.1.2 [1]

Purpose: Ensure that the IUT, while a dialog has been established, on receipt of a BYE request without TAG in the To header, sends a Call/Transaction does not exist (481 Call/Transaction does not exist).

TPId: SIP_CC_TE_CR_V_009

Status: Recommended

Ref: 12.2.2 [1]

Purpose: Ensure that the IUT, once a dialog has been established, on receipt of a BYE request including a CSeq header set with a more than one higher value as in the previous request, sends a Success (200 OK) response with the same CSeq value.

TPId: SIP_CC_TE_CR_V_010
Status: Mandatory
Ref: 12.2.1.1 [1]
Purpose: Ensure that the IUT once a dialog has been established, to release it sends a BYE request with a To header set to the same value as in the From header of the previous received request.

TPId: SIP_CC_TE_CR_V_011
Status: Mandatory
Ref: 12.2.1.1 [1]
Purpose: Ensure that the IUT once a dialog has been established, to release it sends a BYE request with a From header set to the same value as in the To header of the last sent response.

TPId: SIP_CC_TE_CR_V_012
Status: Mandatory
Ref: 12.2.1.1 [1]
Purpose: Ensure that the IUT once a dialog has been established with an INVITE request including no Record-Route header set, to release it sends a BYE request with the Request-URI set to the Contact URI included in the original INVITE request and with no Route header set.

TPId: SIP_CC_TE_CR_V_013
Status: Mandatory
Ref: 12.2.1.1 [1]
Purpose: Ensure that the IUT once a dialog has been established with an INVITE request including a Record-Route header set to a list in which the last element contains lr parameter, to release the call, sends a BYE request with the Request-URI set to the Contact URI and a Route header set to the list in a reverse order of the Record-Route included in the original INVITE request.

TPId: SIP_CC_TE_CR_V_014
Status: Mandatory
Ref: 12.2.1.1 [1]
Purpose: Ensure that the IUT once a dialog has been established with an INVITE request including a Record-Route header set to a list in which the last element does not contains lr parameter, to release the call, sends a BYE request with the Request-URI set to this element and a Route header set to the remainder list in a reverse order of the received Record-Route appended with the received Contact URI.

- TPId:** SIP_CC_TE_CR_V_015
- Status:** Recommended
- Ref:** 9.2 [1]
- Purpose:** Ensure that the IUT when a server INVITE transaction is in the Proceeding state, on receipt of a CANCEL, sends a Success (200 Success) response.
-
- TPId:** SIP_CC_TE_CR_V_016
- Status:** Recommended
- Ref:** 9.2 [1]
- Purpose:** Ensure that the IUT when a server INVITE transaction is in the Proceeding state, on receipt of a CANCEL answers to the original INVITE, request with a Request Terminated (487 Request Terminated) response.
-
- TPId:** SIP_CC_TE_CR_V_017
- Status:** Recommended
- Ref:** 9.2 [1]
- Purpose:** Ensure that the IUT when a server INVITE transaction is in the Proceeding state, on receipt of a CANCEL request including a Via header set with a different branch parameter starting with the magic cookie "z9hG4bK" but with the Request-URI, To tag, From tag, Call-ID and CSeq identical as in the original INVITE request, sends a Call Leg/Transaction Does Not Exist (481 Call Leg/Transaction Does Not Exist) response.
-
- TPId:** SIP_CC_TE_CR_V_018
- Status:** Recommended
- Ref:** 9.2 [1], 17.2.3 [1]
- Purpose:** Ensure that the IUT when a server INVITE transaction is in the Proceeding state, on receipt of a CANCEL request including a Via header set to an identical branch parameter starting with the magic cookie "z9hG4bK" and a different sent-by value, but with the Request-URI, To tag, From tag, Call-ID and CSeq identical as in the original INVITE request, sends a Call Leg/Transaction Does Not Exist (481 Call Leg/Transaction Does Not Exist) response.
-
- TPId:** SIP_CC_TE_CR_V_019
- Status:** Recommended
- Ref:** 9.2 [1], 17.2.3 [1]
- Purpose:** Ensure that the IUT when a server INVITE transaction is in the Proceeding state, on receipt of a CANCEL request, including a top Via header set to a different value but with the Request-URI, To tag, From tag, Call-ID and CSeq identical as in the original INVITE request, sends a Call Leg/Transaction Does Not Exist (481 Call Leg/Transaction Does Not Exist) response.

TPId: SIP_CC_TE_CR_V_020
Status: Mandatory
Ref: 17.2.3 [1], 17.2.2 [1], 12.2.1.1 [1], 15.1.2 [1]
Purpose: Ensure that the IUT, having already answer to a BYE request, on receipt of a BYE request, before timer J fires, including a Via header set with the same branch parameter in the topmost list value, repeats its last response.

TPId: SIP_CC_TE_CR_V_021
Status: Mandatory
Ref: 17.2.3 [1], 17.2.2 [1], 15.1.2 [1]
Purpose: Ensure that the IUT, having already answer to a BYE request, on receipt of a BYE request, before timer J fires, including a Via header set with no branch parameter but with the Request-URI, To tag, From tag, Call-ID and CSeq identical as in the first BYE request, repeats its last response.

TPId: SIP_CC_TE_CR_V_022
Status: Mandatory
Ref: 17.2.3 [1], 17.2.2 [1], 12.2.1.1 [1], 15.1.2 [1]
Purpose: Ensure that the IUT, having already answer to a BYE request, on receipt of a BYE request, before timer J fires, including a Via header set with a different branch parameter but with the Request-URI, To tag, From tag, Call-ID and CSeq identical as in the first BYE request, repeats its last response.

5.3.2.2.2 Invalid Behaviour

TPId: SIP_CC_TE_CR_I_001
Status: Mandatory
Ref: 12.2.2 [1]
Purpose: Ensure that the IUT on receipt of a BYE request with a CSeq number set to a lower value than in the preceding INVITE request, sends a 500 (Server Internal Error) response.

TPId: SIP_CC_TE_CR_I_002
Status: Mandatory
Ref: 8.2.2.3 [1]
Purpose: Ensure that the IUT when a server INVITE transaction is in the Proceeding state, on receipt of a CANCEL request including a Require header set with an option-tag that it does not support, sends a Success (200 OK) response.

TPId: SIP_CC_TE_CR_I_003
Status: Mandatory
Ref: 8.2.2.3 [1]
Purpose: Ensure that the IUT when a server INVITE transaction is in the Proceeding state, on receipt of a CANCEL request including a Proxy-Require header set with an option-tag that it does not support, sends a Success (200 OK) response.

TPId: SIP_CC_TE_CR_I_004
Status: Recommended
Ref: 9.2 [1], 15.1.2 [1]
Purpose: Ensure that the IUT while no session has been initiated, on receipt of a CANCEL request, sends a Call/transaction Does Not Exist (481 Call/transaction Does Not Exist) response.

TPId: SIP_CC_TE_CR_I_005
Status: Recommended
Ref: 15.1.2 [1]
Purpose: Ensure that the IUT, while a session has been released, on receipt of a BYE request, sends a Call/transaction Does Not Exist (481 Call/transaction Does Not Exist) response.

5.3.2.2.3 Timers

TPId: SIP_CC_TE_CR_TI_001
Status: Mandatory
Ref: Annex A [1], 17.2.2 [1]
Purpose: If an unreliable transport is used, ensure that the IUT, when a BYE server transaction is in the Completed state, on receipt of the repetitions of the BYE request, retransmits its response until the timer J set to $64 * T1$ expires.

5.3.2.3 Session modification

5.3.2.3.1 Valid Behaviour

TPId: SIP_CC_TE_SM_V_001
Status: Mandatory
Ref: 14 [1]
Purpose: Ensure that the IUT while a session has been established, on receipt of a re-INVITE request with a higher CSeq and a new complete session description sends a Success (200 OK) response including the last received CSeq.

TPId: SIP_CC_TE_SM_V_002
Status: Mandatory
Ref: 14 [1]
Purpose: Ensure that the IUT while a session has been established, on receipt of a re-INVITE request with no session description sends a Success (200 OK) response.

TPId: SIP_CC_TE_SM_V_003
Status: Recommended
Ref: 14 [1]
Purpose: Ensure that the IUT having sent a Success (200 OK) response to a re-INVITE request and receiving no ACK message, sends a BYE request for the dialog.

5.3.2.3.2 Invalid Behaviour

TPId: SIP_CC_TE_SM_I_001
Status: Mandatory
Ref: 14 [1]
Purpose: Ensure that the IUT when an INVITE server transaction is in the Proceeding state, on receipt of a re-INVITE with a lower CSeq values, sends a Server Internal Error (500 Server Internal Error) response including a Retry-After header set to a randomly chosen value between 0 and 10 seconds.

5.3.3 Proxy

GroupSelection: IUT is a Proxy.

5.3.3.1 Message processing

5.3.3.1.1 Request

5.3.3.1.1.1 Valid Behaviour

TPId: SIP_CC_PR_MP_RQ_V_001
Status: Recommended
Ref: 16.3 item 2 [1]
Purpose: Ensure that the IUT on receipt of an INVITE request with a Request-URI with a scheme that it does not understand, sends a Unsupported URI Scheme (416 Unsupported URI Scheme) request failure response.

TPId: SIP_CC_PR_MP_RQ_V_002
Status: Mandatory
Ref: 16.3 item 3 [1]
Purpose: Ensure that the IUT on receipt of an INVITE request including a Max-Forwards header set to 0, sends a Too many hops (483 Too many hops) request failure response.

TPId: SIP_CC_PR_MP_RQ_V_003

Status: Mandatory

Ref: 16.3 item 5 [1]

Purpose: Ensure that the IUT on receipt of an INVITE request including a Proxy-Require header set to a value that it does not understand, sends a Bad Extension (420 Bad Extension) request failure response including a list of the options that it does not support in the Unsupported header.

TPId: SIP_CC_PR_MP_RQ_V_004

Status: Mandatory

Ref: 16.4 [1]

Purpose: Ensure that the IUT on receipt of an INVITE request with the Request-URI with a maddr parameter indicating a value the proxy is responsible for and the request was received using the port and transport indicated, removes the maddr and any non default port or transport parameter from the request and forwards the message.

TPId: SIP_CC_PR_MP_RQ_V_005

Status: Mandatory

Ref: 16.4 [1]

Purpose: Ensure that the IUT on receipt of an INVITE request including a Route header with the first value indicates the IUT, removes that value from the request and forwards the message.

TPId: SIP_CC_PR_MP_RQ_V_006

Status: Mandatory

Ref: 16.5 [1]

Purpose: Ensure that the IUT on receipt of an INVITE request with the Request-URI with a maddr parameter, indicating a value the proxy is not responsible for, forwards the message to the target indicated in the Request-URI.

TPId: SIP_CC_PR_MP_RQ_V_007

Status: Mandatory

Ref: 16.5 [1]

Purpose: Ensure that the IUT on receipt of an INVITE request with the Request-URI, indicating a domain the proxy is not responsible for, forwards the message to the target indicated in the Request-URI.

TPId: SIP_CC_PR_MP_RQ_V_008
Status: Recommended
Ref: 16.5 [1]
Purpose: Ensure that the IUT on receipt of an INVITE request but does not contain sufficient information to determine the target set, sends back a Ambiguous (485 Ambiguous) request failure response.

TPId: SIP_CC_PR_MP_RQ_V_009
Status: Mandatory
Ref: 16.5 [1]
Purpose: Ensure that the IUT on receipt of an INVITE request with the Request-URI, indicating a resource, which does not exist at this proxy, sends back a Not found (404 Not found) request failure response.

TPId: SIP_CC_PR_MP_RQ_V_010
Status: Recommended
Ref: 16.5 [1]
Purpose: Ensure that the IUT on receipt of an INVITE request but does not find any target to forward, sends back a Temporary Unavailable (480 Temporary Unavailable) request failure response.

TPId: SIP_CC_PR_MP_RQ_V_011
Status: Mandatory
Ref: 16.6 item 3 [1]
Purpose: Ensure that the IUT on receipt of an INVITE request including a Max-Forwards header set to 5, forwards it after having decreasing this counter of one.

TPId: SIP_CC_PR_MP_RQ_V_012
Status: Mandatory
Ref: 16.6 item 3 [1]
Purpose: Ensure that the IUT on receipt of an INVITE request including a Max-Forwards header set to 1, forwards it after having decreasing this counter of one.

TPId: SIP_CC_PR_MP_RQ_V_013
Status: Mandatory
Ref: 16.6 item 3 [1]
Purpose: Ensure that the IUT on receipt of an INVITE request, without a Max-Forwards header, forwards it after having added a Max-Forwards header.

- TPId:** SIP_CC_PR_MP_RQ_V_014
- Status:** Recommended
- Ref:** 16.6 item 3 [1]
- Purpose:** Ensure that the IUT on receipt of an INVITE request, without a Max-Forwards header, forwards it after having added a Max-Forwards header with the value set to 70.
-
- TPId:** SIP_CC_PR_MP_RQ_V_015
- Status:** Mandatory
- Ref:** 16.6 item 6 [1]
- Purpose:** Ensure that the IUT on receipt of an INVITE request with a Route header, and the first URI of this Route does not contain a lr parameter, put the Request-URI into the last position of the Route header, and put the first value of the Route header into the Request-URI, and then forwards the message.
-
- TPId:** SIP_CC_PR_MP_RQ_V_016
- Status:** Mandatory
- Ref:** 16.6 item 7 [1]
- Purpose:** Ensure that the IUT on receipt of an INVITE request with a Route header, and the first URI of this Route containing a lr parameter, forwards the message to the address in the first element of Route header.
-
- TPId:** SIP_CC_PR_MP_RQ_V_017
- Status:** Mandatory
- Ref:** 16.6 item 7 [1]
- Purpose:** Ensure that the IUT on receipt of an INVITE request without a Route header, forwards the message to the address in the Request-URI.
-
- TPId:** SIP_CC_PR_MP_RQ_V_018
- Status:** Mandatory
- Ref:** 16.6 item 8 [1], 8.1.1.7 [1]
- Purpose:** Ensure that the IUT on receipt of an INVITE request forwards the message after having inserted in first position a Via header set to its location with a protocol name set to SIP, a protocol version set to 2.0 and a branch parameter beginning with "z9hG4bK" - to the received list of Via headers.

TPId: SIP_CC_PR_MP_RQ_V_019
Status: Mandatory
Ref: 16.4 [1]
Purpose: Ensure that the IUT on receipt of an ACK request with the Request-URI with a maddr parameter indicating a value the proxy is responsible for and the request was received using the port and transport indicated, removes the maddr and any non default port or transport parameter from the request and forwards the message.

TPId: SIP_CC_PR_MP_RQ_V_020
Status: Mandatory
Ref: 16.4 [1]
Purpose: Ensure that the IUT on receipt of an ACK request including a Route header with the first value indicates the IUT, removes that value from the request and forwards the message.

TPId: SIP_CC_PR_MP_RQ_V_021
Status: Mandatory
Ref: 16.5 [1]
Purpose: Ensure that the IUT on receipt of an ACK request with the Request-URI with a maddr parameter, indicating a value the proxy is not responsible for, forwards the message to the target indicated in the Request-URI.

TPId: SIP_CC_PR_MP_RQ_V_022
Status: Mandatory
Ref: 16.5 [1]
Purpose: Ensure that the IUT on receipt of an ACK request with the Request-URI, indicating a domain the proxy is not responsible for, forwards the message to the target indicated in the Request-URI.

TPId: SIP_CC_PR_MP_RQ_V_023
Status: Mandatory
Ref: 16.6 item 3 [1]
Purpose: Ensure that the IUT on receipt of an ACK request including a Max-Forwards header set to 5, forwards after having decreasing this counter of one.

TPId: SIP_CC_PR_MP_RQ_V_024
Status: Mandatory
Ref: 16.6 item 3 [1]
Purpose: Ensure that the IUT on receipt of an ACK request including a Max-Forwards header set to 1, forwards it after having decreasing this counter of one.

TPId: SIP_CC_PR_MP_RQ_V_025

Status: Mandatory

Ref: 16.6 item 3 [1]

Purpose: Ensure that the IUT on receipt of an ACK request without a Max-Forwards header, forwards it after having added a Max-Forwards header.

TPId: SIP_CC_PR_MP_RQ_V_026

Status: Recommended

Ref: 16.6 item 3 [1]

Purpose: Ensure that the IUT on receipt of an ACK request without a Max-Forwards header, forwards it after having added a Max-Forwards header with the value set to 70.

TPId: SIP_CC_PR_MP_RQ_V_027

Status: Mandatory

Ref: 16.6 item 6 and 7 [1]

Purpose: Ensure that the IUT on receipt of an ACK request with a Route header, and the first URI of this Route does not contain a lr parameter, put the Request-URI into the last position of the Route header, and put the first value of the Route header into the Request-URI, and then forwards the message to the address in the Request-URI.

TPId: SIP_CC_PR_MP_RQ_V_028

Status: Mandatory

Ref: 16.6 item 7 [1]

Purpose: Ensure that the IUT on receipt of an ACK request with a Route header, and the first URI of this Route does not contain a lr parameter, forwards the message to the address in the first element of Route header.

TPId: SIP_CC_PR_MP_RQ_V_029

Status: Mandatory

Ref: 16.6 item 7 [1]

Purpose: Ensure that the IUT on receipt of an ACK request without a Route header, forwards the message to the address in the Request-URI.

TPId: SIP_CC_PR_MP_RQ_V_030

Status: Mandatory

Ref: 16.6 item 8 [1], 8.1.1.7 [1]

Purpose: Ensure that the IUT on receipt of an ACK request forwards the message after having inserted in first position a Via header - set to its location with a protocol name set to SIP, a protocol version set to 2.0 and a branch parameter beginning with "z9hG4bK" - to the received list of Via headers.

TPId: SIP_CC_PR_MP_RQ_V_031

Status: Recommended

Ref: 16.3 item 2 [1] 16.10 [1]

Purpose: Ensure that the IUT on receipt of a CANCEL request that does not correspond to an existing context with a Request-URI with a scheme that it does not understand, sends a Unsupported URI Scheme (416 Unsupported URI Scheme) request failure response.

TPId: SIP_CC_PR_MP_RQ_V_032

Status: Mandatory

Ref: 16.3 item 3 [1] , 16.10 [1]

Purpose: Ensure that the IUT on receipt of a CANCEL request that does not correspond to an existing context including a Max-Forwards header set to 0, sends a Too many hops (483 Too many hops) request failure response.

TPId: SIP_CC_PR_MP_RQ_V_033

Status: Mandatory

Ref: 16.3 item 5 [1], 16.10 [1]

Purpose: Ensure that the IUT on receipt of a CANCEL request that does not correspond to an existing context including a Proxy-Require header set to a value that it does not understand, sends a Bad Extension (420 Bad Extension) request failure response including a list of the options that it does not support in the Unsupported header.

TPId: SIP_CC_PR_MP_RQ_V_034

Status: Mandatory

Ref: 16.4 [1], 16.10 [1]

Purpose: Ensure that the IUT on receipt of a CANCEL request that does not correspond to an existing context with the Request-URI with a maddr parameter indicating a value the proxy is responsible for and the request was received using the port and transport indicated, removes the maddr and any non default port or transport parameter from the request and forwards the message.

TPId: SIP_CC_PR_MP_RQ_V_035

Status: Mandatory

Ref: 16.4 [1], 16.10 [1]

Purpose: Ensure that the IUT on receipt of a CANCEL request that does not correspond to an existing context including a Route header with the first value indicates the IUT, removes that value from the request and forwards the message.

TPId: SIP_CC_PR_MP_RQ_V_036

Status: Mandatory

Ref: 16.5 [1], 16.10 [1]

Purpose: Ensure that the IUT on receipt of a CANCEL request that does not correspond to an existing context with the Request-URI with a maddr parameter, indicating a value the proxy is not responsible for, forwards the message to the target indicated in the Request-URI.

TPId: SIP_CC_PR_MP_RQ_V_037

Status: Mandatory

Ref: 16.5 [1], 16.10 [1]

Purpose: Ensure that the IUT on receipt of a CANCEL request that does not correspond to an existing context with the Request-URI, indicating a domain the proxy is not responsible for, forwards the message to the target indicated in the Request-URI.

TPId: SIP_CC_PR_MP_RQ_V_038

Status: Recommended

Ref: 16.5 [1], 16.10 [1]

Purpose: Ensure that the IUT on receipt of a CANCEL request that does not correspond to an existing context but does not sufficient information to determine the target set, sends back a Ambiguous (485 Ambiguous) request failure response.

TPId: SIP_CC_PR_MP_RQ_V_039

Status: Mandatory

Ref: 16.5 [1], 16.10 [1]

Purpose: Ensure that the IUT on receipt of a CANCEL request that does not correspond to an existing context with the Request-URI, indicating a resource, which does not exist at this proxy, sends back a Not found (404 Not found) request failure response.

TPId: SIP_CC_PR_MP_RQ_V_040

Status: Recommended

Ref: 16.5 [1], 16.10 [1]

Purpose: Ensure that the IUT on receipt of a CANCEL request that does not correspond to an existing context but does not find any target to forward, sends back a Temporary Unavailable (480 Temporary Unavailable) request failure response.

TPId: SIP_CC_PR_MP_RQ_V_041

Status: Mandatory

Ref: 16.6 item 3 [1], 16.10 [1]

Purpose: Ensure that the IUT on receipt of a CANCEL request that does not correspond to an existing context including a Max-Forwards header set to 5, forwards it after having decreasing this counter of one.

TPId: SIP_CC_PR_MP_RQ_V_042

Status: Mandatory

Ref: 16.6 item 3 [1], 16.10 [1]

Purpose: Ensure that the IUT on receipt of a CANCEL request that does not correspond to an existing context including a Max-Forwards header set to 1, forwards it after having decreasing this counter of one.

TPId: SIP_CC_PR_MP_RQ_V_043

Status: Mandatory

Ref: 16.6 item 3 [1], 16.10 [1]

Purpose: Ensure that the IUT on receipt of a CANCEL request that does not correspond to an existing context, without a Max-Forwards header, forwards it after having added a Max-Forwards header.

TPId: SIP_CC_PR_MP_RQ_V_044

Status: Recommended

Ref: 16.6 item 3 [1], 16.10 [1]

Purpose: Ensure that the IUT on receipt of a CANCEL request that does not correspond to an existing context, without a Max-Forwards header, forwards it after having added a Max-Forwards header with the value set to 70.

TPId: SIP_CC_PR_MP_RQ_V_045

Status: Mandatory

Ref: 16.6 item 6 and 7 [1], 16.10 [1]

Purpose: Ensure that the IUT on receipt of a CANCEL request that does not correspond to an existing context with a Route header, and the first URI of this route does not contain a lr parameter, put the Request-URI into the last position of the Route header, and put the first value of the Route header into the Request-URI, and then forwards the message to the address in the Request-URI.

TPId: SIP_CC_PR_MP_RQ_V_046

Status: Mandatory

Ref: 16.6 item 7 [1], 16.10 [1]

Purpose: Ensure that the IUT on receipt of a CANCEL request that does not correspond to an existing context with a Route header, and the first URI of that containing a lr parameter, forwards the message to the address in the first element of Route header.

TPId: SIP_CC_PR_MP_RQ_V_047

Status: Recommended

Ref: 16.6 item 7 [1], 16.10 [1]

Purpose: Ensure that the IUT on receipt of a CANCEL request that does not correspond to an existing context without a Route header, forwards the message to the address in the Request-URI.

TPId: SIP_CC_PR_MP_RQ_V_048

Status: Mandatory

Ref: 16.6 item 8 [1], 8.1.1.7 [1], 16.10 [1]

Purpose: Ensure that the IUT on receipt of a CANCEL request that does not correspond to an existing context forwards the message after having inserted in first position a Via header - set to its location with a protocol name set to SIP, a protocol version set to 2.0 and a branch parameter beginning with "z9hG4bK" - to the received list of Via headers.

TPId: SIP_CC_PR_MP_RQ_V_049

Status: Recommended

Ref: 16.3 item 2 [1]

Purpose: Ensure that the IUT on receipt of a BYE request with a Request-URI with a scheme that it does not understand, sends a Unsupported URI Scheme (416 Unsupported URI Scheme) request failure response.

TPId: SIP_CC_PR_MP_RQ_V_050

Status: Mandatory

Ref: 16.3 item 3 [1]

Purpose: Ensure that the IUT on receipt of a BYE request including a Max-Forwards header set to 0, sends a Too many hops (483 Too many hops) request failure response.

TPId: SIP_CC_PR_MP_RQ_V_051

Status: Mandatory

Ref: 16.3 item 5 [1]

Purpose: Ensure that the IUT on receipt of a BYE request including a Proxy-Require header set to a value that it does not understand, sends a Bad Extension (420 Bad Extension) request failure response including a list of the options that it does not support in the Unsupported header.

- TPId:** SIP_CC_PR_MP_RQ_V_052
- Status:** Mandatory
- Ref:** 16.4 [1]
- Purpose:** Ensure that the IUT on receipt of a BYE request with the Request-URI with a maddr parameter indicating a value the proxy is responsible for and the request was received using the port and transport indicated, removes the maddr and any non default port or transport parameter from the request and forwards the message.
-
- TPId:** SIP_CC_PR_MP_RQ_V_053
- Status:** Mandatory
- Ref:** 16.4 [1]
- Purpose:** Ensure that the IUT on receipt of a BYE request including a Route header with the first value indicates the IUT, removes that value from the request and forwards the message.
-
- TPId:** SIP_CC_PR_MP_RQ_V_054
- Status:** Mandatory
- Ref:** 16.5 [1]
- Purpose:** Ensure that the IUT on receipt of a BYE request with the Request-URI with a maddr parameter, indicating a value the proxy is not responsible for, forwards the message to the target indicated in the Request-URI.
-
- TPId:** SIP_CC_PR_MP_RQ_V_055
- Status:** Mandatory
- Ref:** 16.5 [1]
- Purpose:** Ensure that the IUT on receipt of a BYE request with the Request-URI, indicating a domain the proxy is not responsible for, forwards the message to the target indicated in the Request-URI.
-
- TPId:** SIP_CC_PR_MP_RQ_V_056
- Status:** Recommended
- Ref:** 16.5 [1]
- Purpose:** Ensure that the IUT on receipt of a BYE request but does not contain sufficient information to determine the target set, sends back a Ambiguous (485 Ambiguous) request failure response.
-
- TPId:** SIP_CC_PR_MP_RQ_V_057
- Status:** Mandatory
- Ref:** 16.5 [1]
- Purpose:** Ensure that the IUT on receipt of a BYE request with the Request-URI, indicating a resource, which does not exist at this proxy, sends back a Not found (404 Not found) request failure response.

TPId: SIP_CC_PR_MP_RQ_V_058

Status: Recommended

Ref: 16.5 [1]

Purpose: Ensure that the IUT on receipt of a BYE request but does not find any target to forward, sends back a Temporary Unavailable (480 Temporary Unavailable) request failure response.

TPId: SIP_CC_PR_MP_RQ_V_059

Status: Mandatory

Ref: 16.6 item 3 [1]

Purpose: Ensure that the IUT on receipt of a BYE request including a Max-Forwards header set to 5, forwards it after having decreasing this counter of one.

TPId: SIP_CC_PR_MP_RQ_V_060

Status: Mandatory

Ref: 16.6 item 3 [1]

Purpose: Ensure that the IUT on receipt of a BYE request including a Max-Forwards header set to 1, forwards it after having decreasing this counter of one.

TPId: SIP_CC_PR_MP_RQ_V_061

Status: Mandatory

Ref: 16.6 item 3 [1]

Purpose: Ensure that the IUT on receipt of a BYE request, without a Max-Forwards header, forwards it after having added a Max-Forwards header.

TPId: SIP_CC_PR_MP_RQ_V_062

Status: Recommended

Ref: 16.6 item 3 [1]

Purpose: Ensure that the IUT on receipt of a BYE request, without a Max-Forwards header, forwards it after having added a Max-Forwards header with the value set to 70.

TPId: SIP_CC_PR_MP_RQ_V_063

Status: Mandatory

Ref: 16.6 item 6 and 7 [1]

Purpose: Ensure that the IUT on receipt of a BYE request with a Route header, and the first URI of this route does not contain a lr parameter, put the Request-URI into the last position of the Route header, and put the first value of the Route header into the Request-URI, and then forwards the message to the address in the Request-URI.

TPId: SIP_CC_PR_MP_RQ_V_064
Status: Mandatory
Ref: 16.6 item 7 [1]
Purpose: Ensure that the IUT on receipt of a BYE request with a Route header, and the first URI of that containing a lr parameter, forwards the message to the address in the first element of Route header.

TPId: SIP_CC_PR_MP_RQ_V_065
Status: Mandatory
Ref: 16.6 item 7 [1]
Purpose: Ensure that the IUT on receipt of a BYE request without a Route header, forwards the message to the address in the Request-URI.

TPId: SIP_CC_PR_MP_RQ_V_066
Status: Mandatory
Ref: 16.6 item 8 [1], 8.1.1.7 [1]
Purpose: Ensure that the IUT on receipt of a BYE request forwards the message after having inserted in first position a Via header - set to its location with a protocol name set to SIP, a protocol version set to 2.0 and a branch parameter beginning with "z9hG4bK" - to the received list of Via headers.

TPId: SIP_CC_PR_MP_RQ_V_067
Status: Mandatory for Proxy that is able to fork
Ref: 16.6 item 7 and 10 [1], 16.5 [1]
Purpose: Ensure that the IUT on receipt of an INVITE request and the determined target set is containing two URIs forwards the message (forking) to both URIs.

5.3.3.1.1.2 Invalid Behaviour

TPId: SIP_CC_PR_MP_RQ_I_001
Status: Mandatory
Ref: 16.6 item 2 [1]
Purpose: Ensure that the IUT on receipt of an INVITE request with the Request-URI containing a not allowed parameter, removes this parameter from the Request-URI before forwarding that message.

TPId: SIP_CC_PR_MP_RQ_I_002
Status: Mandatory
Ref: 16.6 item 2 [1]
Purpose: Ensure that the IUT on receipt of an ACK request, with the Request-URI containing a not allowed parameter, removes that parameter from the Request-URI before forwarding that message.

TPId: SIP_CC_PR_MP_RQ_I_003
Status: Mandatory
Ref: 16.6 item 2 [1]
Purpose: Ensure that the IUT on receipt of a CANCEL request with the Request-URI containing a not allowed parameter, removes that parameter from the Request-URI before forwarding that message.

TPId: SIP_CC_PR_MP_RQ_I_004
Status: Mandatory
Ref: 16.6 item 2 [1]
Purpose: Ensure that the IUT on receipt of a BYE request with the Request-URI containing a not allowed parameter, removes that parameter from the Request-URI before forwarding that message.

5.3.3.1.2 Response

5.3.3.1.2.1 Valid Behaviour

TPId: SIP_CC_PR_MP_RS_V_001
Status: Mandatory
Ref: 16.7 [1], 16.11 [1]
Purpose: Ensure that the IUT on receipt of a Success (200 OK) response with the topmost Via header indicating its own location, deletes that header and forwards the message to the address indicated in the next Via header value.

TPId: SIP_CC_PR_MP_RS_V_002
Status: Mandatory
Ref: 16.11 [1], 18.1.2 [1]
Purpose: Ensure that the IUT on receipt of a Success (200 OK) response with the topmost Via header not indicating its own location, does not forward the message.

TPId: SIP_CC_PR_MP_RS_V_003
Status: Mandatory
Ref: 16.7 [1], 16.11 [1]
Purpose: Ensure that the IUT on receipt of a Success (200 OK) response with the topmost Via header indicating its own location, but the branch parameter of Via header together with the method parameter in the CSeq header does not corresponds to any existing transaction, deletes that Via header and forwards the message to the address indicated in the next Via header value.

TPId: SIP_CC_PR_MP_RS_V_004

Status: Mandatory

Ref: 16.7 item 3 [1], 16.11 [1]

Purpose: Ensure that the IUT, on receipt of a Success (200 OK) response that does not match to an existing client transaction with a single Via header, does not forward the message.

TPId: SIP_CC_PR_MP_RS_V_005

Status: Mandatory

Ref: 16.7 [1], 16.11 [1]

Purpose: Ensure that the IUT, on receipt of a Success (200 OK) response that matches to an existing client transaction, removes the topmost via from the response and forwards it to the address indicated in the next Via header.

TPId: SIP_CC_PR_MP_RS_V_006

Status: Mandatory for Stateless

Ref: 16.7 [1], 16.11 [1]

Purpose: Ensure that the IUT, on receipt of a Trying (100 Trying) provisional response that does not match to an existing client transaction, removes the topmost via from the response and forwards it to the address indicated in the next Via header.

TPId: SIP_CC_PR_MP_RS_V_007

Status: Mandatory

Ref: 16.7 [1], 16.11 [1]

Purpose: Ensure that the IUT, on receipt of a Ringing (180 Ringing) provisional response that does not match to an existing client transaction, removes the topmost via from the response and forwards it to the address indicated in the next Via header.

TPId: SIP_CC_PR_MP_RS_V_008

Status: Mandatory

Ref: 16.7 [1], 16.11 [1]

Purpose: Ensure that the IUT on receipt of a Moved Temporarily (302 Moved Temporarily) Redirection response that does not match to an existing client transaction, removes the topmost via from the response and forwards it to the address indicated in the next Via header.

TPId: SIP_CC_PR_MP_RS_V_009

Status: Mandatory

Ref: 16.7 [1], 16.11 [1]

Purpose: Ensure that the IUT on receipt of a Gone (410 Gone) Request failure response that does not match to an existing client transaction, removes the topmost via from the response and forwards it to the address indicated in the next Via header.

TPId: SIP_CC_PR_MP_RS_V_010

Status: Mandatory

Ref: 16.7 [1], 16.11 [1]

Purpose: Ensure that the IUT on receipt of a Server Internal Error (500 Server Internal Error) server failure response that does not match to an existing client transaction, removes the topmost via from the response and forwards it to the address indicated in the next Via header.

TPId: SIP_CC_PR_MP_RS_V_011

Status: Mandatory

Ref: 16.7 [1], 16.11 [1]

Purpose: Ensure that the IUT on receipt of a Decline (603 Decline) Global failure response that does not match to an existing client transaction, removes the topmost via from the response and forwards it to the address indicated in the next Via header.

TPId: SIP_CC_PR_MP_RS_V_012

Status: Mandatory for Stateful Proxy

Ref: 16.7 item 5 [1]

Purpose: Ensure that the IUT having already proxy an INVITE, on receipt of a Ringing (180 Ringing) provisional response matching to an existing client transaction, removes the topmost via from the response and forwards it to the address indicated in the next Via header.

TPId: SIP_CC_PR_MP_RS_V_013

Status: Mandatory for Stateful Proxy

Ref: 16.7 item 5 [1]

Purpose: Ensure that the IUT having already proxy an INVITE, on receipt of a Moved Temporarily (302 Moved Temporarily) Redirection response matching to an existing client transaction, removes the topmost via from the response and forwards it to the address indicated in the next Via header.

TPId: SIP_CC_PR_MP_RS_V_014

Status: Mandatory for Stateful Proxy

Ref: 16.7 item 5 [1]

Purpose: Ensure that the IUT having already proxy an INVITE, on receipt of a Gone (410 Gone) Request failure response matching to an existing client transaction, removes the topmost via from the response and forwards it to the address indicated in the next Via header.

TPId: SIP_CC_PR_MP_RS_V_015

Status: Mandatory for Stateful Proxy

Ref: 16.7 item 5 [1]

Purpose: Ensure that the IUT having already proxy an INVITE, on receipt of a Server Internal Error (500 Server Internal Error) server failure response matching to an existing client transaction, removes the topmost via from the response and forwards it to the address indicated in the next Via header.

TPId: SIP_CC_PR_MP_RS_V_016

Status: Recommended for Stateful Proxy

Ref: 16.7 item 5 and 6 [1]

Purpose: Ensure that the IUT having already proxy an INVITE, on receipt of a Service Unavailable (503 Service Unavailable) server failure response matching to an existing client transaction, generates a Server Internal Error (500 Server Internal Error) server failure response, and forwards it.

TPId: SIP_CC_PR_MP_RS_V_017

Status: Mandatory for Stateful Proxy

Ref: 16.7 item 5 [1]

Purpose: Ensure that the IUT having already proxy an INVITE, on receipt of a Decline (603 Decline) Global failure response matching to an existing client transaction, removes the topmost via from the response and forwards it to the address indicated in the next Via header.

TPId: SIP_CC_PR_MP_RS_V_018

Status: Mandatory for a Stateful Proxy that is able to fork

Ref: 16.7 [1] item 6

Purpose: Ensure that the IUT, after forking an INVITE to two locations and having received a 302 response from one client transaction, on receipt of a 200 response from the other client transaction, forwards the 200 response.

TPId: SIP_CC_PR_MP_RS_V_019

Status: Mandatory for a Stateful Proxy that is able to fork

Ref: 16.7 [1] item 6

Purpose: Ensure that the IUT, after forking an INVITE to two locations and having received a 302 response from one client transaction, on receipt of a 302 response from the other client transaction, forwards the 302 response.

TPId: SIP_CC_PR_MP_RS_V_020

Status: Recommended for a Stateful Proxy that is able to fork

Ref: 16.7 [1] item 6

Purpose: Ensure that the IUT, after forking an INVITE to two locations and having received a 302 response from one client transaction, on receipt of a 486 response from the other client transaction, forwards the 302 response.

TPId: SIP_CC_PR_MP_RS_V_021

Status: Recommended for a Stateful Proxy that is able to fork

Ref: 16.7 [1] item 6

Purpose: Ensure that the IUT, after forking an INVITE to two locations and having received a 302 response from one client transaction, on receipt of a 500 response from the other client transaction, forwards the 302 response.

TPId: SIP_CC_PR_MP_RS_V_022

Status: Mandatory for a Stateful Proxy that is able to fork

Ref: 16.7 [1] item 6

Purpose: Ensure that the IUT, after forking an INVITE to two locations and having received a 302 response from one client transaction, on receipt of a 603 response from the other client transaction, forwards the 603 response.

TPId: SIP_CC_PR_MP_RS_V_023

Status: Mandatory for a Stateful Proxy that is able to fork

Ref: 16.7 [1] item 6

Purpose: Ensure that the IUT, after forking an INVITE to two locations and having received a 486 response from one client transaction, on receipt of a 200 response from the other client transaction, forwards the 200 response.

TPId: SIP_CC_PR_MP_RS_V_024

Status: Recommended for a Stateful Proxy that is able to fork

Ref: 16.7 [1] item 6

Purpose: Ensure that the IUT, after forking an INVITE to two locations and having received a 486 response from one client transaction, on receipt of a 302 response from the other client transaction, forwards the 302 response.

TPId: SIP_CC_PR_MP_RS_V_025

Status: Mandatory for a Stateful Proxy that is able to fork

Ref: 16.7 [1] item 6

Purpose: Ensure that the IUT, after forking an INVITE to two locations and having received a 486 response from one client transaction, on receipt of a 486 response from the other client transaction, forwards the 486 response.

TPId: SIP_CC_PR_MP_RS_V_026

Status: Recommended for a Stateful Proxy that is able to fork

Ref: 16.7 [1] item 6

Purpose: Ensure that the IUT, after forking an INVITE to two locations and having received a 486 400 response from one client transaction, on receipt of a 401 response from the other client transaction, forwards the 401 response.

TPId: SIP_CC_PR_MP_RS_V_027

Status: Recommended for a Stateful Proxy that is able to fork

Ref: 16.7 [1] item 6

Purpose: Ensure that the IUT, after forking an INVITE to two locations and having received a 486 response from one client transaction, on receipt of a 407 response from the other client transaction, forwards the 407 response.

TPId: SIP_CC_PR_MP_RS_V_028

Status: Recommended for a Stateful Proxy that is able to fork

Ref: 16.7 [1] item 6

Purpose: Ensure that the IUT, after forking an INVITE to two locations and having received a 486 response from one client transaction, on receipt of a 415 response from the other client transaction, forwards the 415 response.

- TPId:** SIP_CC_PR_MP_RS_V_029
- Status:** Recommended for a Stateful Proxy that is able to fork
- Ref:** 16.7 [1] item 6
- Purpose:** Ensure that the IUT, after forking an INVITE to two locations and having received a 486 response from one client transaction, on receipt of a 420 response from the other client transaction, forwards the 420 response.
-
- TPId:** SIP_CC_PR_MP_RS_V_030
- Status:** Recommended for a Stateful Proxy that is able to fork
- Ref:** 16.7 [1] item 6
- Purpose:** Ensure that the IUT, after forking an INVITE to two locations and having received a 486 response from one client transaction, on receipt of a 484 response from the other client transaction, forwards the 484 response.
-
- TPId:** SIP_CC_PR_MP_RS_V_031
- Status:** Recommended for a Stateful Proxy that is able to fork
- Ref:** 16.7 [1] item 6
- Purpose:** Ensure that the IUT, after forking an INVITE to two locations and having received a 486 response from one client transaction, on receipt of a 500 response from the other client transaction, forwards the 486 response.
-
- TPId:** SIP_CC_PR_MP_RS_V_032
- Status:** Mandatory for a Stateful Proxy that is able to fork
- Ref:** 16.7 [1] item 6
- Purpose:** Ensure that the IUT, after forking an INVITE to two locations and having received a 486 response from one client transaction, on receipt of a 603 response from the other client transaction, forwards the 603 response.
-
- TPId:** SIP_CC_PR_MP_RS_V_033
- Status:** Mandatory for a Stateful Proxy that is able to fork
- Ref:** 16.3 item 7 [1]
- Purpose:** Ensure that the IUT, after forking an INVITE to two locations and having received a 401 response from one client transaction, on receipt of a 401 response from the other client transaction, forwards the 401 response including all WWW-Authenticate and Proxy-Authenticate headers collected from the received responses.

- TPId:** SIP_CC_PR_MP_RS_V_034
- Status:** Mandatory for a Stateful Proxy that is able to fork
- Ref:** 16.3 item 7 [1]
- Purpose:** Ensure that the IUT, after forking an INVITE to two locations and having received a 407 response from one client transaction, on receipt of a 407 response from the other client transaction, forwards the 407 response including all Proxy-Authenticate headers collected from the received responses.
-
- TPId:** SIP_CC_PR_MP_RS_V_035
- Status:** Recommended for a Stateful Proxy that is able to fork
- Ref:** 16.7 [1] item 6
- Purpose:** Ensure that the IUT, after forking an INVITE to two locations and having received a 500 response from one client transaction, on receipt of a 200 response from the other client transaction, forwards the 200 response.
-
- TPId:** SIP_CC_PR_MP_RS_V_036
- Status:** Recommended for a Stateful Proxy that is able to fork
- Ref:** 16.7 [1] item 6
- Purpose:** Ensure that the IUT, after forking an INVITE to two locations and having received a 500 response from one client transaction, on receipt of a 302 response from the other client transaction, forwards the 302 response.
-
- TPId:** SIP_CC_PR_MP_RS_V_037
- Status:** Recommended for a Stateful Proxy that is able to fork
- Ref:** 16.7 [1] item 6
- Purpose:** Ensure that the IUT, after forking an INVITE to two locations and having received a 500 response from one client transaction, on receipt of a 486 response from the other client transaction, forwards the 486 response.
-
- TPId:** SIP_CC_PR_MP_RS_V_038
- Status:** Recommended for a Stateful Proxy that is able to fork
- Ref:** 16.7 [1] item 6
- Purpose:** Ensure that the IUT, after forking an INVITE to two locations and having received a 503 response from one client transaction, on receipt of a 500 response from the other client transaction, forwards the 500 response.

- TPId:** SIP_CC_PR_MP_RS_V_039
- Status:** Recommended for a Stateful Proxy that is able to fork
- Ref:** 16.7 [1] item 6
- Purpose:** Ensure that the IUT, after forking an INVITE to two locations and having received a 503 response from one client transaction, on receipt of a 503 response from the other client transaction, forwards the 500 response.
-
- TPId:** SIP_CC_PR_MP_RS_V_040
- Status:** Mandatory for a Stateful Proxy that is able to fork
- Ref:** 16.71 item 6
- Purpose:** Ensure that the IUT, after forking an INVITE to two locations and having received a 300 response from one client transaction, on receipt of a 603 response from the other client transaction, forwards the 603 response.
-
- TPId:** SIP_CC_PR_MP_RS_V_041
- Status:** Mandatory for a Stateful Proxy that is able to fork
- Ref:** 16.7 [1] item 6
- Purpose:** Ensure that the IUT, after forking an INVITE to two locations and having received a 302 response from one client transaction, on receipt of a 180 response from the other client transaction, forwards the 180 response.
-
- TPId:** SIP_CC_PR_MP_RS_V_042
- Status:** Mandatory for a Stateful Proxy that is able to fork
- Ref:** 16.7 [1] item 6
- Purpose:** Ensure that the IUT, after forking an INVITE to two locations and having received a 486 response from one client transaction, on receipt of a 180 response from the other client transaction, forwards the 180 response.
-
- TPId:** SIP_CC_PR_MP_RS_V_043
- Status:** Mandatory for a Stateful Proxy that is able to fork
- Ref:** 16.7 [1] item 6
- Purpose:** Ensure that the IUT, after forking an INVITE to two locations and having received a 500 response from one client transaction, on receipt of a 180 response from the other client transaction, forwards the 180 response.

TPId: SIP_CC_PR_MP_RS_V_044

Status: Mandatory for a Stateful Proxy that is able to fork

Ref: 16.7 [1] item 6

Purpose: Ensure that the IUT, after forking an INVITE to two locations and having received (and forwarded) a 180 response from one client transaction, on receipt of a 182 response from the other client transaction, forwards the 182 response.

TPId: SIP_CC_PR_MP_RS_V_045

Status: Mandatory for a Stateful Proxy that is able to fork

Ref: 16.7 [1] item 6

Purpose: Ensure that the IUT, after forking an INVITE to two locations and having received (and forwarded) a 180 response from one client transaction, on receipt of a 200 response from the other client transaction, forwards the 200 response.

TPId: SIP_CC_PR_MP_RS_V_046

Status: Mandatory for a Stateful Proxy that is able to fork

Ref: 16.7 [1] item 10

Purpose: Ensure that the IUT, after forking an INVITE to two locations and having received (and forwarded) a 180 response from one client transaction, on receipt of a 200 response from the other client transaction, sends a CANCEL request to the first client transaction with the same Call-ID, From header, To header, Request-URI, CSeq number as in the previous INVITE, with a single Via header same as topmost Via of the previous INVITE and the CSeq method set to CANCEL.

TPId: SIP_CC_PR_MP_RS_V_047

Status: Mandatory for a Stateful Proxy that is able to fork

Ref: 16.7 [1] item 6

Purpose: Ensure that the IUT, after forking an INVITE to two locations and having received (and forwarded) a 180 response from one client transaction, on receipt of a 302 response from the other client transaction, does not forward the 302 response immediately.

TPId: SIP_CC_PR_MP_RS_V_048

Status: Mandatory for a Stateful Proxy that is able to fork

Ref: 16.7 [1] item 6

Purpose: Ensure that the IUT, after forking an INVITE to two locations and having received (and forwarded) a 180 response from one client transaction, on receipt of a 486 response from the other client transaction, does not forward the 486 response immediately.

TPId: SIP_CC_PR_MP_RS_V_049

Status: Mandatory for a Stateful Proxy that is able to fork

Ref: 16.7 [1] item 6

Purpose: Ensure that the IUT, after forking an INVITE to two locations and having received (and forwarded) a 180 response from one client transaction, on receipt of a 500 response from the other client transaction, does not forward the 500 response immediately.

TPId: SIP_CC_PR_MP_RS_V_050

Status: Mandatory for a Stateful Proxy that is able to fork

Ref: 16.7 [1] item 10

Purpose: Ensure that the IUT, after forking an INVITE to two locations and having received (and forwarded) a 180 response from one client transaction, on receipt of a 603 response from the other client transaction, sends a CANCEL request to the first client transaction with the same Call-ID, From header, To header, Request-URI, CSeq number as in the previous INVITE, with a single Via header same as topmost Via of the previous INVITE and the CSeq method set to CANCEL.

TPId: SIP_CC_PR_MP_RS_V_051

Status: Mandatory for a Stateful Proxy that is able to fork

Ref: 16.7 [1] item 10

Purpose: Ensure that the IUT, after forking an INVITE to two locations and having received (and forwarded) a 200 response from one client transaction, on receipt of a 180 response from the other client transaction, sends a CANCEL request to that client transaction with the same Call-ID, From header, To header, Request-URI, CSeq number as in the previous INVITE, with a single Via header same as topmost Via of the previous INVITE and the CSeq method set to CANCEL.

TPId: SIP_CC_PR_MP_RS_V_052

Status: Mandatory for a Stateful Proxy that is able to fork

Ref: 16.7 [1] item 10

Purpose: Ensure that the IUT, after forking an INVITE to two locations and having received (and forwarded) a 603 response from one client transaction, on receipt of a 180 response from the other client transaction, sends a CANCEL request to that client transaction with the same Call-ID, From header, To header, Request-URI, CSeq number as in the previous INVITE, with a single Via header same as topmost Via of the previous INVITE and the CSeq method set to CANCEL.

TPId: SIP_CC_PR_MP_RS_V_053

Status: Mandatory for a Stateful Proxy that is able to fork

Ref: 16.7 [1] item 10, 16.7 [1] item 5

Purpose: Ensure that the IUT, after forking an INVITE to two locations and having received a 603 response from one client transaction, and having sent a CANCEL to the second client transaction, on receipt of a 487 response from the other client transaction, forwards the 603 response.

5.3.3.2 Transaction

5.3.3.2.1 Client

5.3.3.2.1.1 Valid Behaviour

TPId: SIP_CC_PR_TR_CL_V_001

Status: Mandatory for Stateful Proxy

Ref: 16.10 [1], 9.1 [1]

Purpose: Ensure that the IUT, on receipt of a CANCEL at server side matching to a response context and the related client transaction is in the INVITE Proceeding state, sends a CANCEL from the related pending client transaction with the Request-URI, Call-ID, To, From headers, CSeq number identical as in the INVITE request to be cancelled and the CSeq method set to CANCEL.

TPId: SIP_CC_PR_TR_CL_V_002

Status: Mandatory for Stateful Proxy

Ref: 16.10 [1], 9.1 [1]

Purpose: Ensure that the IUT, on receipt of a CANCEL at server side matching to a response context and the related client transaction is in the INVITE Proceeding state, sends a CANCEL from the related pending client transaction with the Via header identical as in topmost Via header in the INVITE request to be cancelled.

TPId: SIP_CC_PR_TR_CL_V_003

Status: Mandatory for Stateful Proxy

Ref: 16.10 [1], 9.1 [1]

Purpose: Ensure that the IUT, on receipt of a CANCEL at server side matching to a response context, but the related client transaction is in the INVITE Calling state, does not send a CANCEL.

TPId: SIP_CC_PR_TR_CL_V_004

Status: Mandatory for Stateful Proxy

Ref: 16.10 [1], 9.1 [1]

Purpose: Ensure that the IUT, having received a CANCEL request matching to a response context while the related client transaction is in the INVITE Calling state, on receipt of a provisional response, sends a CANCEL from the related client transaction.

TPId: SIP_CC_PR_TR_CL_V_005

Status: Mandatory for Stateful Proxy

Ref: 16.10 [1], 9.1 [1]

Purpose: Ensure that the IUT, having received a CANCEL request matching to a response context while the related client transaction is in the INVITE Calling state, on receipt of a final response, does not send a CANCEL from the related client transaction.

TPId: SIP_CC_PR_TR_CL_V_006

Status: Mandatory for a Stateful Proxy

Ref: 16.7 [1], 17.1.1.3 [1]

Purpose: Ensure that the IUT in the INVITE Client Calling state on receipt of a Moved Temporarily (302 Moved Temporarily) Redirection response matching to an existing client transaction, responds with an ACK request, with the same Call-ID, From header, Request-URI, CSeq number as in the previous INVITE, with a single Via header same as topmost Via of the previous INVITE and the To header the same value as the To header in the received response and the CSeq method set to ACK.

TPId: SIP_CC_PR_TR_CL_V_007

Status: Mandatory for a Stateful Proxy

Ref: 16.7 [1], 17.1.1.3 [1]

Purpose: Ensure that the IUT in the INVITE Client Calling state on receipt of a Gone (410 Gone) Request failure response matching to an existing client transaction, responds with an ACK request, with the same Call-ID, From header, Request-URI, CSeq number as in the previous INVITE, with a single Via header same as topmost Via of the previous INVITE and the To header the same value as the To header in the received response and the CSeq method set to ACK.

TPId: SIP_CC_PR_TR_CL_V_008

Status: Mandatory for a Stateful Proxy

Ref: 16.7 [1], 17.1.1.3 [1]

Purpose: Ensure that the IUT in the INVITE Client Calling state on receipt of a Service Unavailable (503 Service Unavailable) server failure response matching to an existing client transaction, responds with an ACK request, with the same Call-ID, From header, Request-URI, CSeq number as in the previous INVITE, with a single Via header same as topmost Via of the previous INVITE and the To header the same value as the To header in the received response and the CSeq method set to ACK.

TPId: SIP_CC_PR_TR_CL_V_009

Status: Mandatory for a Stateful Proxy

Ref: 16.7 [1], 17.1.1.3 [1]

Purpose: Ensure that the IUT in the INVITE Client Calling state on receipt of a Decline (603 Decline) Global failure response matching to an existing client transaction, responds with an ACK request, with the same Call-ID, From header, Request-URI, CSeq number as in the previous INVITE, with a single Via header same as topmost Via of the previous INVITE and the To header the same value as the To header in the received response and the CSeq method set to ACK.

TPId: SIP_CC_PR_TR_CL_V_010

Status: Mandatory for Stateful Proxy

Ref: 17.1.1.2 [1], figure 5 [1]

Purpose: Ensure that the IUT, when an INVITE client transaction is in the Calling state, on receipt of a Trying (100 Trying) response enters in the Proceeding state.

TPId: SIP_CC_PR_TR_CL_V_011
Status: Mandatory for Stateful Proxy
Ref: 17.1.1.2 [1], figure 5 [1]
Purpose: Ensure that the IUT, when an INVITE client transaction is in the Calling state, on receipt of a Session Progress (183 Session Progress) response enters in the Proceeding state.

5.3.3.2.1.2 Timers

TPId: SIP_CC_PR_TR_CL_TI_001
Status: Mandatory for Stateful Proxy
Ref: Annex A [1], 17.1.1.1 [1]
Purpose: If an unreliable transport (UDP) is used, ensure that the IUT, when an INVITE client transaction is in the Calling state repeats its INVITE request on the timeout condition of timer A set with a value of T1.

TPId: SIP_CC_PR_TR_CL_TI_002
Status: Recommended for Stateful Proxy
Ref: Annex A [1], 17.1.1.1 [1]
Purpose: If a reliable transport (TCP) is used, ensure that the IUT, when an INVITE client transaction is in the Calling state does not repeat its INVITE request on the timeout condition of timer A set with a value of T1.

TPId: SIP_CC_PR_TR_CL_TI_003
Status: Mandatory for Stateful Proxy
Ref: Annex A [1], 17.1.1.1 [1]
Purpose: If an unreliable transport (UDP) is used, ensure that the IUT, when an INVITE client transaction is in the Calling state having already repeated its INVITE wait for a timer A set with a value of $2 \cdot T1$ before sending it again.

TPId: SIP_CC_PR_TR_CL_TI_004
Status: Mandatory for Stateful Proxy
Ref: Annex A [1], 17.1.1.1 [1]
Purpose: If an unreliable transport (UDP) is used, ensure that the IUT, when an INVITE client transaction is in the Calling state retransmits its INVITE request with intervals that double after each transmission.

TPId: SIP_CC_PR_TR_CL_TI_005
Status: Mandatory for Stateful Proxy
Ref: Annex A [1], 17.1.1.1 [1]
Purpose: Ensure that the IUT, when an INVITE client transaction is in the Calling state, when timer B set to a value of $64 * T1$ expires, does not send an ACK.

TPId: SIP_CC_PR_TR_CL_TI_006
Status: Recommended for Stateful Proxy
Ref: Annex A [1], 17.1.1.1 [1]
Purpose: Ensure that the IUT, when an INVITE client transaction is in the Calling state, when timer B set to a value of $64 * T1$ expires, considers the transaction terminated.

TPId: SIP_CC_PR_TR_CL_TI_007
Status: Recommended for Stateful Proxy
Ref: Annex A [1], 17.1.1.1 [1]
Purpose: Ensure that the IUT, when an INVITE client transaction is in the Proceeding state, does not repeat its INVITE request.

TPId: SIP_CC_PR_TR_CL_TI_008
Status: Recommended for Stateful Proxy
Ref: Annex A [1], 17.1.1.1 [1]
Purpose: If an unreliable transport is used, ensure that the IUT, when an INVITE client transaction is in the Completed state, on receipt of a final response that matches the transaction, repeats its ACK request until timer D set to at least 32 second expires.

TPId: SIP_CC_PR_TR_CL_TI_009
Status: Recommended for Stateful Proxy
Ref: Annex A [1], 17.1.1.1 [1]
Purpose: If a reliable transport is used, ensure that the IUT, when an INVITE client transaction is in the Completed state, on receipt of a final response that matches the transaction, does not repeats its ACK request.

TPId: SIP_CC_PR_TR_CL_TI_010
Status: Recommended for Stateful Proxy
Ref: Annex A [1], 17.1.1.1 [1]
Purpose: If an unreliable transport is used, ensure that the IUT, when an INVITE client transaction is in the Completed state, on receipt of new final responses with different Via branch parameter value, does not repeat its ACK request until timer D set to at least 32 second expires.

- TPId:** SIP_CC_PR_TR_CL_TI_011
- Status:** Mandatory for Stateful Proxy
- Ref:** Annex A [1], 13.2.2.4 [1]
- Purpose:** Ensure that the IUT, when an INVITE client transaction has been in the Terminated state, on receipt of a retransmitted Success (200 OK) responses sends an ACK request until $64 * T1$ duration expires.
-
- TPId:** SIP_CC_PR_TR_CL_TI_012
- Status:** Mandatory for Stateful Proxy
- Ref:** Annex A [1], 17.1.2.2 [1]
- Purpose:** If an unreliable transport is used, ensure that the IUT, when a BYE client transaction is in the Trying state having sent a BYE request, repeats its request after timer E set to $T1$ value expires.
-
- TPId:** SIP_CC_PR_TR_CL_TI_013
- Status:** Mandatory for Stateful Proxy
- Ref:** Annex A [1], 17.1.2.2 [1]
- Purpose:** If an unreliable transport is used, ensure that the IUT, when a BYE client transaction is in the Trying state having sent twice times a BYE request, repeats its request after timer E set to the $\text{MIN}(2 * T1, T2)$ value expires.
-
- TPId:** SIP_CC_PR_TR_CL_TI_014
- Status:** Mandatory for Stateful Proxy
- Ref:** Annex A [1], 17.1.2.2 [1]
- Purpose:** If an unreliable transport is used, ensure that the IUT, when a BYE client transaction is in the Trying state having sent three times a BYE request, repeats its request after timer E set to the $\text{MIN}(4 * T1, T2)$ value expires.
-
- TPId:** SIP_CC_PR_TR_CL_TI_015
- Status:** Recommended for Stateful Proxy
- Ref:** Annex A [1], 17.1.2.2 [1]
- Purpose:** If an unreliable transport is used, ensure that the IUT, when a BYE client transaction is in the Trying state does not repeat a BYE request, after timer F set to $64 * T1$ expires.
-
- TPId:** SIP_CC_PR_TR_CL_TI_016
- Status:** Mandatory for Stateful Proxy
- Ref:** Annex A [1], 17.1.2.2 [1]
- Purpose:** Ensure that the IUT, when a BYE client transaction is in the Proceeding state, repeats its BYE request after timer E set in Trying state to $T1$ value expires.

TPId: SIP_CC_PR_TR_CL_TI_017
Status: Mandatory for Stateful Proxy
Ref: Annex A [1], 17.1.2.2 [1]
Purpose: Ensure that the IUT, when a BYE client transaction is in the Proceeding state and BYE request have been already repeated in this state, repeats its BYE request after timer E set to T2 value expires.

TPId: SIP_CC_PR_TR_CL_TI_018
Status: Mandatory for Stateful Proxy
Ref: Annex A [1], 17.1.2.2 [1]
Purpose: Ensure that the IUT, when a BYE client transaction is in the Proceeding state, does not repeat a BYE request on an established dialog, after timer F set to 64*T1 expires.

TPId: SIP_CC_PR_TR_CL_TI_019
Status: Recommended for Stateful Proxy
Ref: Annex A [1], 17.1.2.2 [1], 9.1 [1],
Purpose: Ensure that the IUT, when a BYE client transaction is in the Trying state, considers the transaction terminated after 64*T1 duration expires without receiving any final response.

5.3.3.2.2 Server

5.3.3.2.2.1 Valid Behaviour

TPId: SIP_CC_PR_TR_SE_V_001
Status: Mandatory for Stateful Proxy
Ref: 16.2 [1]
Purpose: Ensure that the IUT on receipt of an INVITE request, sends a provisional (100 Trying) response.

TPId: SIP_CC_PR_TR_SE_V_002
Status: Mandatory for Stateful Proxy
Ref: 16.2 [1], 8.2.6.2 [1]
Purpose: Ensure that the IUT, on receipt of an INVITE request, sends a provisional (100 Trying) response including the headers From, Call-Id, CSeq and Via copied from from the INVITE message.

TPId: SIP_CC_PR_TR_SE_V_003
Status: Mandatory for Stateful Proxy
Ref: 16.2 [1], 8.2.6.2 [1], 17.2.1 [1]
Purpose: Ensure that the IUT, on receipt of an INVITE request with no "tag" set on the To header, sends a provisional (100 Trying) response including the same URI and no tag in the To header.

TPId: SIP_CC_PR_TR_SE_V_004

Status: Mandatory for Stateful Proxy

Ref: 16.2 [1], 8.2.6.2 [1], 17.2.1 [1]

Purpose: Ensure that the IUT, on receipt of an INVITE request with a "tag" set on the To header, sends a provisional (100 Trying) response including the same URI and the same tag in the To header.

TPId: SIP_CC_PR_TR_SE_V_005

Status: Mandatory for Stateful Proxy

Ref: 16.2 [1], 8.2.6.1 [1]

Purpose: Ensure that the IUT, on receipt of an INVITE request with a Timestamp header, sends a provisional (100 Trying) response with a Timestamp header.

TPId: SIP_CC_PR_TR_SE_V_006

Status: Mandatory for Stateful Proxy

Ref: 17.2.1 [1], 17.2.3 [1]

Purpose: Ensure that the IUT in a server INVITE Proceeding state, on receipt of an INVITE request, including a Via header set with the same branch parameter and sent-by value in the topmost list value, repeats its last response.

TPId: SIP_CC_PR_TR_SE_V_007

Status: Mandatory for Stateful Proxy

Ref: 17.2.1 [1], 17.2.3 [1]

Purpose: Ensure that the IUT in a server INVITE Proceeding state, on receipt of an INVITE request, including a Via header set with no branch parameter but with the Request-URI, To tag, From tag, Call-ID, CSeq and top Via header identical as in the first INVITE request, repeats its last response.

TPId: SIP_CC_PR_TR_SE_V_008

Status: Mandatory for Stateful Proxy

Ref: 17.2.1 [1], 17.2.3 [1]

Purpose: Ensure that the IUT in a server INVITE Proceeding state, on receipt of an INVITE request, including a Via header set with a different branch parameter without the magic cookie "z9hG4bK" but with the Request-URI, To tag, From tag, Call-ID, CSeq and top Via header identical as in the first INVITE request, repeats its last response.

TPId: SIP_CC_PR_TR_SE_V_009

Status: Recommended for Stateful Proxy

Ref: 17.2.1 [1], 17.2.3 [1]

Purpose: Ensure that the IUT in a server INVITE Completed state, on receipt of an INVITE request, including a Via header set with the same branch parameter and sent-by value in the topmost list value, repeats its last response.

- TPId:** SIP_CC_PR_TR_SE_V_010
- Status:** Recommended for Stateful Proxy
- Ref:** 17.2.1 [1], 17.2.3 [1]
- Purpose:** Ensure that the IUT in a server INVITE Completed state, on receipt of an INVITE request, including a Via header set with no branch parameter but with the Request-URI, To tag, From tag, Call-ID, CSeq and top Via header identical as in the first INVITE request, repeats its last response.
-
- TPId:** SIP_CC_PR_TR_SE_V_011
- Status:** Recommended for Stateful Proxy
- Ref:** 17.2.1 [1], 17.2.3 [1]
- Purpose:** Ensure that the IUT in a server INVITE Completed state, on receipt of an INVITE request, including a Via header set with a different branch parameter without the magic cookie "z9hG4bK" but with the Request-URI, To tag, From tag, Call-ID, CSeq and top Via header identical as in the first INVITE request, repeats its last response.
-
- TPId:** SIP_CC_PR_TR_SE_V_012
- Status:** Mandatory for Stateful Proxy
- Ref:** 17.2.2 [1], 17.2.3 [1]
- Purpose:** Ensure that the IUT in a server BYE Proceeding state, on receipt of a BYE request, including a Via header set with the same branch parameter and sent-by value in the topmost list value, repeats its last response.
-
- TPId:** SIP_CC_PR_TR_SE_V_013
- Status:** Mandatory for Stateful Proxy
- Ref:** 17.2.2 [1], 17.2.3 [1]
- Purpose:** Ensure that the IUT in a server BYE Proceeding state, on receipt of a BYE request, including a Via header set with no branch parameter but with the Request-URI, To tag, From tag, Call-ID, CSeq and top Via header identical as in the first BYE request, repeats its last response.
-
- TPId:** SIP_CC_PR_TR_SE_V_014
- Status:** Mandatory for Stateful Proxy
- Ref:** 17.2.2 [1], 17.2.3 [1]
- Purpose:** Ensure that the IUT in a server BYE Proceeding state, on receipt of a BYE request, including a Via header set with a different branch parameter without the magic cookie "z9hG4bK" but with the Request-URI, To tag, From tag, Call-ID, CSeq and top Via header identical as in the first BYE request, repeats its last response.

- TPId:** SIP_CC_PR_TR_SE_V_015
- Status:** Recommended for Stateful Proxy
- Ref:** 17.2.2 [1], 17.2.3 [1]
- Purpose:** Ensure that the IUT in a server BYE Completed state, on receipt of a BYE request, including a Via header set with the same branch parameter and sent-by value in the topmost list, repeats its last response.
-
- TPId:** SIP_CC_PR_TR_SE_V_016
- Status:** Recommended for Stateful Proxy
- Ref:** 17.2.2 [1], 17.2.3 [1]
- Purpose:** Ensure that the IUT in a server BYE Completed state, on receipt of a BYE request, including a Via header set with no branch parameter but with the Request-URI, To tag, From tag, Call-ID, CSeq and top Via header identical as in the first BYE request, repeats its last response.
-
- TPId:** SIP_CC_PR_TR_SE_V_017
- Status:** Recommended for Stateful Proxy
- Ref:** 17.2.2 [1], 17.2.3 [1]
- Purpose:** Ensure that the IUT in a server BYE Completed state, on receipt of a BYE request, including a Via header set with a different branch parameter without the magic cookie "z9hG4bK" but with the Request-URI, To tag, From tag, Call-ID, CSeq and top Via header identical as in the first BYE request, repeats its last response.
-
- TPId:** SIP_CC_PR_TR_SE_V_018
- Status:** Mandatory for Stateful Proxy
- Ref:** 16.10 [1], 9.2 [1]
- Purpose:** Ensure that the IUT in a server INVITE Proceeding state, on receipt of a CANCEL, including a Via header set with the same branch parameter and sent-by value with the topmost Via value INVITE to be cancelled, sends a Success (200 Success) response to the CANCEL request.
-
- TPId:** SIP_CC_PR_TR_SE_V_019
- Status:** Recommended for Stateful Proxy
- Ref:** 9.2 [1]
- Purpose:** Ensure that the IUT in a server INVITE Proceeding state, on receipt of a CANCEL, including a Via header set with the same branch parameter and sent-by value with the topmost Via value INVITE to be cancelled, answers to the original INVITE request with a Request Terminated (487 Request Terminated) response.

- TPId:** SIP_CC_PR_TR_SE_V_020
- Status:** Mandatory for Stateful Proxy
- Ref:** 16.10 [1], 9.2 [1]
- Purpose:** Ensure that the IUT in a server INVITE Proceeding state, on receipt of a CANCEL, including a Via header set with no branch parameter but with the Request-URI, To tag, From tag, Call-ID, CSeq number and top Via header identical as in the INVITE to be cancelled, sends a Success (200 Success) response to the CANCEL request.
- TPId:** SIP_CC_PR_TR_SE_V_021
- Status:** Recommended for Stateful Proxy
- Ref:** 9.2 [1]
- Purpose:** Ensure that the IUT in a server INVITE Proceeding state, on receipt of a CANCEL, including a Via header set with no branch parameter but with the Request-URI, To tag, From tag, Call-ID, CSeq number and top Via header identical as in the INVITE to be cancelled, answers to the original INVITE, request with a Request Terminated (487 Request Terminated) response.
- TPId:** SIP_CC_PR_TR_SE_V_022
- Status:** Mandatory for Stateful Proxy
- Ref:** 16.10 [1], 9.2 [1]
- Purpose:** Ensure that the IUT in a server INVITE Proceeding state, on receipt of a CANCEL, including a Via header set with a different branch parameter without the magic cookie "z9hG4bK" but with the Request-URI, To tag, From tag, Call-ID, CSeq number and top Via header identical as in the INVITE to be cancelled, sends a Success (200 Success) response to the CANCEL request.
- TPId:** SIP_CC_PR_TR_SE_V_023
- Status:** Recommended for Stateful Proxy
- Ref:** 9.2 [1]
- Purpose:** Ensure that the IUT in a server INVITE Proceeding state, on receipt of a CANCEL, including a Via header set with a different branch parameter without the magic cookie "z9hG4bK" but with the Request-URI, To tag, From tag, Call-ID, CSeq number and top Via header identical as in the INVITE to be cancelled, answers to the original INVITE, request with a Request Terminated (487 Request Terminated) response.
- TPId:** SIP_CC_PR_TR_SE_V_024
- Status:** Mandatory for Stateful Proxy using UDP
- Ref:** 17.2.1 [1], 17.2.3 [1]
- Purpose:** Ensure that the IUT in a server INVITE Confirmed state, on receipt of an ACK request, including a Via header set with the same branch parameter and sent-by value in the topmost list value, does not forward the message.

TPId: SIP_CC_PR_TR_SE_V_025
Status: Mandatory for Stateful Proxy using UDP
Ref: 17.2.1 [1], 17.2.3 [1]
Purpose: Ensure that the IUT in a server INVITE Confirmed state, on receipt of an ACK request, including a Via header set with no branch parameter but with the Request-URI, To tag, From tag, Call-ID, CSeq number and top Via header identical as in the first INVITE request, does not forward the message.

TPId: SIP_CC_PR_TR_SE_V_026
Status: Mandatory for Stateful Proxy using UDP
Ref: 17.2.1 [1]
Purpose: Ensure that the IUT in a server INVITE Confirmed state, on receipt of an ACK request, including a Via header set with a different branch parameter without the magic cookie "z9hG4bK" but with the Request-URI, To tag, From tag, Call-ID, CSeq number and top Via header identical as in the first INVITE request, does not forward the message.

TPId: SIP_CC_PR_TR_SE_V_027
Status: Mandatory for Stateful Proxy
Ref: 17.2.3.1 [1], 13.3.1.4 [1], figure 7 [1]
Purpose: Ensure that the IUT in a server INVITE Proceeding state, after sending a 4XX response, enters in the Completed state.

TPId: SIP_CC_PR_TR_SE_V_028
Status: Mandatory for Stateful Proxy
Ref: 17.2.3.1 [1], 13.3.1.4 [1], figure 7 [1]
Purpose: Ensure that the IUT in a server INVITE Completed state, on receipt of an ACK request, enters in the Confirmed state.

TPId: SIP_CC_PR_TR_SE_V_029
Status: Recommended for Stateful Proxy
Ref: 15.1.2 [1]
Purpose: Ensure that the IUT, while no dialog has been established, on receipt of a BYE request, sends a Call/Transaction does not exist (481 Call/Transaction does not exist).

5.3.3.2.2.2

Timers

TPId: SIP_CC_PR_TR_SE_TI_001

Status: Mandatory for Stateful Proxy

Ref: Annex A [1], 17.2.1 [1]

Purpose: If an unreliable transport is used, ensure that the IUT, when an INVITE server transaction is in the Completed state repeats its response on the timeout condition of timer G set with a value of T1.

TPId: SIP_CC_PR_TR_SE_TI_002

Status: Mandatory for Stateful Proxy

Ref: Annex A [1], 17.2.1 [1]

Purpose: If a reliable transport (TCP) is used, ensure that the IUT, when an INVITE server transaction is in the Completed state does not repeat its response on the timeout condition of timer G set with a value of T1.

TPId: SIP_CC_PR_TR_SE_TI_003

Status: Mandatory for Stateful Proxy

Ref: Annex A [1], 17.2.1 [1]

Purpose: If an unreliable transport is used, ensure that the IUT, when an INVITE server transaction is in the Completed state and having already sent twice times its response, repeats it after timer G set $\text{MIN}(2*T1, T2)$ value expires.

TPId: SIP_CC_PR_TR_SE_TI_004

Status: Mandatory for Stateful Proxy

Ref: Annex A [1], 17.2.1 [1]

Purpose: If an unreliable transport is used, ensure that the IUT, when an INVITE server transaction is in the Completed state and having already sent three times its response, repeats it after timer G set the $\text{MIN}(4*T1, T2)$ value expires.

TPId: SIP_CC_PR_TR_SE_TI_005

Status: Mandatory for Stateful Proxy

Ref: Annex A [1], 17.2.1 [1]

Purpose: Ensure that the IUT, when an INVITE server transaction is in the Completed state and, enters in the Terminated state after timer H set to $64*T1$ value expires.

TPId: SIP_CC_PR_TR_SE_TI_006

Status: Mandatory for Stateful Proxy

Ref: Annex A [1], 17.2.1 [1]

Purpose: If an unreliable transport is used, ensure that the IUT, when an INVITE server transaction is in the Completed state and, does not repeats its response after timer H set to $64*T1$ value expires.

TPId: SIP_CC_PR_TR_SE_TI_007

Status: Mandatory for Stateful Proxy

Ref: Annex A [1], 17.2.1 [1]

Purpose: If an unreliable transport is used, ensure that the IUT, when an INVITE server transaction is in the Confirmed state, enters in the Terminated state after timer I set to T4 value expires.

TPId: SIP_CC_PR_TR_SE_TI_008

Status: Mandatory for Stateful Proxy

Ref: Annex A [1], 17.2.1 [1]

Purpose: If a reliable transport is used, ensure that the IUT, when an INVITE server transaction is in the Confirmed state, enters immediately in the Terminated state.

TPId: SIP_CC_PR_TR_SE_TI_009

Status: Mandatory for Stateful Proxy

Ref: Annex A [1], 17.2.2 [1]

Purpose: If an unreliable transport is used, ensure that the IUT, when a BYE server transaction is in the Completed state, on receipt of the repetitions of the BYE request, retransmits its response until the timer J set to 64*T1 expires.

5.3.4 Redirect Server

GroupSelection: IUT is a Redirect Server.

5.3.4.1 Call establishment

5.3.4.1.1 Valid Behaviour

TPId: SIP_CC_RD_CE_V_001

Status: Mandatory

Ref: 8.3 [1], 8.2.6.2 [1]

Purpose: Ensure that the IUT on receipt of an INVITE request, sends a 3XX redirection response to the caller including a Contact header set to the registered location of the callee and the To header set to the received value with an additional TAG.

TPId: SIP_CC_RD_CE_V_002

Status: Mandatory

Ref: 8.3 [1], 8.2.6.2 [1]

Purpose: Ensure that the IUT on receipt of an INVITE request, sends a 3XX redirection response to the caller after having copy the received Via header into the response.

TPId: SIP_CC_RD_CE_V_003

Status: Mandatory

Ref: 8.3 [1]

Purpose: Ensure that the IUT, having sent a 3XX redirection response, accepts an ACK request.

TPId: SIP_CC_RD_CE_V_004

Status: Mandatory

Ref: 8.3 [1]

Purpose: Ensure that the IUT on receipt of an INVITE request, send a 3XX redirection response to the caller including a Contact header set to the list of locations of the callee previously registered.

TPId: SIP_CC_RD_CE_V_005

Status: Mandatory

Ref: 8.3 [1]

Purpose: Ensure that the IUT on receipt of an INVITE request including a Require header set to a value that it does not understand, sends a 3XX redirection response to the caller.

TPId: SIP_CC_RD_CE_V_006

Status: Mandatory

Ref: 8.3 [1], 21.4.18 [1]

Purpose: Ensure that the IUT on receipt of an INVITE request for a UA for which the registration has expired, sends a Temporarily Unavailable (480 Temporarily Unavailable) request failure response to the caller.

TPId: SIP_CC_RD_CE_V_007

Status: Mandatory

Ref: 8.3 [1], 21.4.5 [1]

Purpose: Ensure that the IUT on receipt of an INVITE request for an unknown UA, sends a Not found (404 Not Found) request failure response to the caller.

TPId: SIP_CC_RD_CE_V_008

Status: Mandatory

Ref: 8.3 [1], 8.2.6.2 [1]

Purpose: Ensure that the IUT on receipt of an BYE request, sends a 3XX redirection response to the caller including a Contact header set to the registered location of the callee.

5.3.4.2 Call release

5.3.4.2.1 Valid Behaviour

TPId: SIP_CC_RD_CR_V_001

Status: Recommended

Ref: 8.3 [1]

Purpose: Ensure that the IUT on receipt of an INVITE request immediately followed by a CANCEL request with the same Call-ID, To, From, top Via header, Request URI and CSeq, sends an OK (200 OK) response to the caller.

TPId: SIP_CC_RD_CR_V_002

Status: Mandatory

Ref: 8.3 [1], 21.4.19 [1]

Purpose: Ensure that the IUT on receipt of a CANCEL request whose Call-ID does not match a pending request, sends a Call Leg/Transaction Does Not Exist (481 Call Leg/Transaction Does Not Exist) request failure to the caller.

5.4 Test Purposes for Messaging

5.4.1 Registrant

GroupSelection: Registration being listed as an option, the test purpose is applicable if the SUT is declared as supporting periodic registration and can behave as User Agent.

5.4.1.1 Valid Behaviour

TPId: SIP_MG_RT_V_001

Status: Mandatory

Ref: 19.1.1 [1]

Purpose: Ensure that the IUT, having sent a REGISTER request, on receipt of a valid Success (200 OK) response including non-understood uri-parameters in SIP-URI of the Contact header, ignores it and considers to have received a Success (200 OK).

TPId: SIP_MG_RT_V_002

Status: Mandatory

Ref: 19.1.1 [1]

Purpose: Ensure that the IUT, having sent a REGISTER request, on receipt of a valid Success (200 OK) response including header parameters in the SIP-URI of the Contact header, considers to have received a Success (200 OK).

TPId: SIP_MG_RT_V_003

Status: Mandatory

Ref: 7.2 [1]

Purpose: Ensure that the IUT, having sent a REGISTER request, on receipt of a valid Success (299 OK) response with non-defined last two digits considers to have received a Success (200 OK).

TPId: SIP_MG_RT_V_004

Status: Mandatory

Ref: 7.2 [1]

Purpose: Ensure that the IUT, having sent a REGISTER request, on receipt of a valid Success (200 PERFECT) response with an unknown reason phrase considers to have received a Success (200 OK).

TPId: SIP_MG_RT_V_005

Status: Mandatory

Ref: 7.3.1 [1]

Purpose: Ensure that the IUT, having sent a REGISTER request, is able to receive a Success (200 OK) response including headers named with upper and lower cases.

TPId: SIP_MG_RT_V_006

Status: Mandatory

Ref: 25.1 [1]

Purpose: Ensure that the IUT, having sent a REGISTER request, is able to receive a Success (200 OK) response including a header set with values preceded by several leading white space and properly extended over multiple lines.

TPId: SIP_MG_RT_V_007

Status: Mandatory

Ref: 25.1 [1], 7.3.3 [1]

Purpose: Ensure that the IUT, having sent a REGISTER request, is able to receive a Success (200 OK) response including headers set with short field names.

TPId: SIP_MG_RT_V_008

Status: Mandatory

Ref: 7.5 [1]

Purpose: Ensure that the IUT, having sent a REGISTER request over a stream-oriented (TCP) transport, on receipt of a Success (200 OK) response with several CRLF before the start ignores them and considers to have received a Success (200 OK).

5.4.1.2 Invalid Behaviour

TPId: SIP_MG_RT_I_001

Status: Mandatory

Ref: 19.1.1 [1]

Purpose: Ensure that the IUT, having sent a REGISTER request, on receipt of a Success (200 OK) response with transport parameters in the From and To headers considers to have received a Success (200 OK).

TPId: SIP_MG_RT_I_002

Status: Mandatory

Ref: 19.1.1 [1]

Purpose: Ensure that the IUT, having sent a REGISTER request, on receipt of a Success (200 OK) response with a ttl parameter in the From and To headers ignores them and considers to have received a Success (200 OK).

TPId: SIP_MG_RT_I_003

Status: Mandatory

Ref: 19.1.1 [1]

Purpose: Ensure that the IUT, having sent a REGISTER request, on receipt of a Success (200 OK) response with an URI including a header parameter in the To and From headers ignores them and considers to have received a Success (200 OK).

TPId: SIP_MG_RT_I_004

Status: Mandatory

Ref: 19.1.1 [1]

Purpose: Ensure that the IUT, having sent a REGISTER request, on receipt of a Success (200 OK) response with a method parameters in the To and From headers ignores them and considers to have received a Success (200 OK).

TPId: SIP_MG_RT_I_005

Status: Mandatory

Ref: 20 [1], table 2 [1]

Purpose: Ensure that the IUT, having sent a REGISTER request, on receipt of a Session Progress (183 Session Progress) response with a Contact header ignores it and accepts the following Success (200 OK).

5.4.2 Registrar

GroupSelection: IUT is a proxy or a redirect server entity.

5.4.2.1 Valid Behaviour

TPId: SIP_MG_RR_V_001

Status: Mandatory

Ref: 19.1.1 [1]

Purpose: Ensure that the IUT on receipt of a REGISTER request including escaped characters in the SIP-URI of the Contact header, sends a Success (200 OK) response.

TPId: SIP_MG_RR_V_002

Status: Mandatory

Ref: 19.1.1 [1]

Purpose: Ensure that the IUT on receipt of a REGISTER request including escaped delimiters in SIP-URI of the Contact header, sends a Success (200 OK) response.

TPId: SIP_MG_RR_V_003

Status: Mandatory

Ref: 19.1.1 [1]

Purpose: Ensure that the IUT on receipt of a REGISTER request including non-understood uri- parameters in SIP-URI of the Contact header, ignores it and sends a Success (200 OK) response.

TPId: SIP_MG_RR_V_004

Status: Mandatory

Ref: 19.1.1 [1]

Purpose: Ensure that the IUT on receipt of a REGISTER request including a header parameter in the SIP-URI of the Contact header, sends a Success (200 OK) response.

TPId: SIP_MG_RR_V_005

Status: Mandatory

Ref: 19.1.1 [1]

Purpose: Ensure that the IUT on receipt of a REGISTER request including a method parameter set to "REGISTER" in the SIP-URI of Contact header, sends a Success (200 OK) response.

TPId: SIP_MG_RR_V_006

Status: Mandatory

Ref: 8.2.2 [1]

Purpose: Ensure that the IUT on receipt of a REGISTER request including an unknown header, ignores them and sends a Success (200 OK) response.

TPId: SIP_MG_RR_V_007

Status: Mandatory

Ref: 7.3.1 [1]

Purpose: Ensure that the IUT on receipt of a REGISTER request including headers named with upper and lower cases, sends a Success (200 OK) response.

TPId: SIP_MG_RR_V_008

Status: Mandatory

Ref: 7.3.1 [1]

Purpose: Ensure that the IUT on receipt of a REGISTER request including headers set with values preceded by several leading white space and properly extended over multiple lines, sends a Success (200 OK) response.

TPId: SIP_MG_RR_V_009

Status: Mandatory

Ref: 7.3.1 [1]

Purpose: Ensure that the IUT on receipt of a REGISTER request including a Contact header set with multiple values separated by a comma, sends a Success (200 OK) response.

TPId: SIP_MG_RR_V_010

Status: Mandatory

Ref: 7.3.1 [1]

Purpose: Ensure that the IUT on receipt of a REGISTER request including multiple Contact headers, sends a Success (200 OK) response.

TPId: SIP_MG_RR_V_011

Status: Mandatory

Ref: 7.3.1 [1]

Purpose: Ensure that the IUT on receipt of a REGISTER request including an expires parameter named with upper and lower cases of Contact header, sends a Success (200 OK) response.

TPId: SIP_MG_RR_V_012

Status: Mandatory

Ref: 7.3.3 [1]

Purpose: Ensure that the IUT on receipt of a REGISTER request including headers set with short names, sends a Success (200 OK) response.

TPId: SIP_MG_RR_V_013
Status: Mandatory
Ref: 7.5 [1]
Purpose: Ensure that the IUT, on receipt of a REGISTER request over a stream-oriented (TCP) transport with several CRLF before the start-line, sends a Success (200 OK) response.

5.4.2.2 Invalid Behaviour

TPId: SIP_MG_RR_I_001
Status: Mandatory
Ref: 7.1 [1]
Purpose: Ensure that the IUT on receipt of a REGISTER request including a Request line SIP-Version in lower cases ignores it and sends a Success (200 OK) response.

TPId: SIP_MG_RR_I_002
Status: Mandatory
Ref: 19.1.1 [1]
Purpose: Ensure that the IUT on receipt of a REGISTER request including ttl parameter in the From and To headers ignores them and sends a Success (200 OK) response.

TPId: SIP_MG_RR_I_003
Status: Mandatory
Ref: 19.1.1 [1]
Purpose: Ensure that the IUT on receipt of a REGISTER request including header parameters in the SIP-URI of the From and To headers ignores them and sends a Success (200 OK) response.

TPId: SIP_MG_RR_I_004
Status: Mandatory
Ref: 19.1.1 [1]
Purpose: Ensure that the IUT on receipt of a REGISTER request including method parameters set to "INVITE" in the SIP-URI of the From and To headers ignores them and sends a Success (200 OK) response.

TPId: SIP_MG_RR_I_005
Status: Mandatory
Ref: 7.3.2 [1], 20 [1], table 2 [1]
Purpose: Ensure that the IUT on receipt of a REGISTER request including an Alert-Info header ignores it and sends a Success (200 OK) response

TPId: SIP_MG_RR_I_006
Status: Recommended
Ref: 21.4.1 [1]
Purpose: Ensure that the IUT on receipt of a REGISTER request without CSeq header sends a Bad Request (400 Bad Request) response

5.4.3 Originating Endpoint

Group Selection: IUT can behave as User Agent client.

5.4.3.1 Valid Behaviour

TPId: SIP_MG_OE_V_001
Status: Mandatory
Ref: 19.1.1 [1]
Purpose: Ensure that the IUT, when an INVITE client transaction is in the Calling state, on receipt of a Success (200 OK) response including non-understood uri-parameters in SIP-URI of the From header, ignores it and sends an ACK request.

TPId: SIP_MG_OE_V_002
Status: Mandatory
Ref: 19.1.1 [1]
Purpose: Ensure that the IUT, when an INVITE client transaction is in the Calling state, on receipt of a Success (200 OK) response including header parameters in the SIP-URI of the Contact header, sends an ACK request.

TPId: SIP_MG_OE_V_003
Status: Mandatory
Ref: 7.2 [1]
Purpose: Ensure that the IUT, when an INVITE client transaction is in the Calling state, on receipt of a Success (299 OK) response with non-defined last two digits, sends an ACK request.

TPId: SIP_MG_OE_V_004
Status: Mandatory
Ref: 7.2 [1]
Purpose: Ensure that the IUT, when an INVITE client transaction is in the Calling state, on receipt of a Success (200 PERFECT) response with an unknown reason phrase, sends an ACK request.

TPId: SIP_MG_OE_V_005
Status: Mandatory
Ref: 7.3.1 [1]
Purpose: Ensure that the IUT, when an INVITE client transaction is in the Calling state, on receipt of a Success (200 OK) response including headers named with upper and lower cases, sends an ACK request.

TPId: SIP_MG_OE_V_006
Status: Mandatory
Ref: 7.3.1 [1]
Purpose: Ensure that the IUT, when an INVITE client transaction is in the Calling state, on receipt of a Success (200 OK) response including headers set with values preceded by several leading white space and properly extended over multiple lines, sends an ACK request.

TPId: SIP_MG_OE_V_007
Status: Mandatory
Ref: 7.3.1 [1]
Purpose: Ensure that the IUT, when an INVITE client transaction is in the Calling state, on receipt of a Success (200 OK) response including a headers set with short names, sends an ACK request.

TPId: SIP_MG_OE_V_008
Status: Mandatory
Ref: 19.1.1 [1]
Purpose: Ensure that the IUT, once a dialog has been established, on receipt of a BYE request including escaped characters in the SIP-URI of the From header, sends a Success (200 OK) response.

TPId: SIP_MG_OE_V_009
Status: Mandatory
Ref: 19.1.1 [1]
Purpose: Ensure that the IUT, once a dialog has been established, on receipt of a BYE request including escaped delimiters in the SIP-URI of the From header, sends a Success (200 OK) response.

TPId: SIP_MG_OE_V_010
Status: Mandatory
Ref: 19.1.1 [1]
Purpose: Ensure that the IUT, once a dialog has been established, on receipt of a BYE request including non-understood uri-parameters in the SIP-URI of the BYE Request-URI, sends a Success (200 OK) response.

TPId: SIP_MG_OE_V_011
Status: Mandatory
Ref: 8.2.2 [1]
Purpose: Ensure that the IUT, once a dialog has been established, on receipt of a BYE request including an unknown header, ignores it and sends a Success (200 OK) response.

TPId: SIP_MG_OE_V_012
Status: Mandatory
Ref: 7.3.1 [1]
Purpose: Ensure that the IUT, once a dialog has been established, on receipt of a BYE request including headers named with upper and lower cases sends a Success (200 OK) response.

TPId: SIP_MG_OE_V_013
Status: Mandatory
Ref: 7.3.1 [1]
Purpose: Ensure that the IUT, once a dialog has been established, on receipt of a BYE request including headers set with values preceded by several leading white space and properly extended over multiple lines, sends a Success (200 OK) response.

TPId: SIP_MG_OE_V_014
Status: Mandatory
Ref: 7.3.3 [1]
Purpose: Ensure that the IUT, once a dialog has been established, on receipt of a BYE request including headers set with short names, sends a Success (200 OK) response.

TPId: SIP_MG_OE_V_015
Status: Mandatory
Ref: 18.1.1 [1]
Purpose: Ensure that the IUT, when an INVITE client transaction is in the Calling state, on receipt of a 65.535 bytes long Success (200 OK) response including session description parameters that it can accept, transported by UDP, sends an ACK request.

5.4.3.2 Invalid Behaviour

TPId: SIP_MG_OE_I_001

Status: Mandatory

Ref: 19.1.1 [1]

Purpose: Ensure that the IUT, when an INVITE client transaction is in the Calling state, on receipt of a Success (200 OK) response including transport parameters in the From and To headers, ignores them and sends an ACK request.

TPId: SIP_MG_OE_I_002

Status: Mandatory

Ref: 19.1.1 [1]

Purpose: Ensure that the IUT, when an INVITE client transaction is in the Calling state, on receipt of a Success (200 OK) response with a ttl parameter in the From and To headers, ignores them and sends an ACK request.

TPId: SIP_MG_OE_I_003

Status: Mandatory

Ref: 19.1.1 [1]

Purpose: Ensure that the IUT, when an INVITE client transaction is in the Calling state, on receipt of a Success (200 OK) response with an URI including a header parameter in the To and From headers ignores them and sends an ACK request.

TPId: SIP_MG_OE_I_004

Status: Mandatory

Ref: 19.1.1 [1]

Purpose: Ensure that the IUT, when an INVITE client transaction is in the Calling state, on receipt of a Success (200 OK) response with a method parameter in the To and From headers ignores them and sends an ACK request.

TPId: SIP_MG_OE_I_005

Status: Mandatory

Ref: 19.1.1 [1]

Purpose: Ensure that the IUT, once a dialog has been established, on receipt of a BYE request including maddr parameters in the From and To headers ignores them and sends a Success (200 OK) response without maddr parameter.

TPId: SIP_MG_OE_I_006
Status: Mandatory
Ref: 19.1.1 [1]
Purpose: Ensure that the IUT, once a dialog has been established, on receipt of a BYE request including header parameters in the SIP-URI of the From and To headers ignores them and sends a Success (200 OK) response.

TPId: SIP_MG_OE_I_007
Status: Mandatory
Ref: 19.1.1 [1]
Purpose: Ensure that the IUT, once a dialog has been established, on receipt of a BYE request including method parameters set to "CANCEL" parameter in the SIP-URI of the From and To headers ignores them and sends a Success (200 OK) response.

TPId: SIP_MG_OE_I_008
Status: Mandatory
Ref: 7.3.2 [1], 20 [1], table 2 [1]
Purpose: Ensure that the IUT, once a dialog has been established, on receipt of a BYE request including an In-Reply-To header ignores it and sends a Success (200 OK) response.

TPId: SIP_MG_OE_I_009
Status: Recommended
Ref: 18.3 [1]
Purpose: Ensure that the IUT, when an INVITE client transaction is in the Calling state while a message-oriented (UDP) transport is used, on receipt of a Success (200 OK) response including a body part shorter than the length indicated in the Content-Length header field, discards it and does not send a ACK request.

TPId: SIP_MG_OE_I_010
Status: Recommended
Ref: 18.3 [1]
Purpose: Ensure that the IUT, when an INVITE client transaction is in the Calling state while a message-oriented (UDP) transport is used, on receipt of a Success (200 OK) response including a body part longer than the length indicated in the Content-Length header field, ignores extra bytes and sends a ACK request.

5.4.4 Terminating Endpoint

GroupSelection: IUT can behave as User Agent server.

5.4.4.1 Valid Behaviour

TPId: SIP_MG_TE_V_001

Status: Mandatory

Ref: 19.1.1 [1]

Purpose: Ensure that the IUT on receipt of an INVITE request including escaped characters in the SIP-URI of the Contact header, sends a Success (200 OK) response preceded optionally by informational (1XX) response.

TPId: SIP_MG_TE_V_002

Status: Mandatory

Ref: 19.1.1 [1]

Purpose: Ensure that the IUT on receipt of an INVITE request including escaped delimiters in the SIP-URI of the Contact header, sends a Success (200 OK) response preceded optionally by informational (1XX) response.

TPId: SIP_MG_TE_V_003

Status: Mandatory

Ref: 19.1.1 [1]

Purpose: Ensure that the IUT on receipt of an INVITE request including non-understood uri-parameters in the SIP-URI of the Contact header, sends a Success (200 OK) response preceded optionally by informational (1XX) response.

TPId: SIP_MG_TE_V_004

Status: Mandatory

Ref: 19.1.1 [1]

Purpose: Ensure that the IUT on receipt of an INVITE request including a header parameter in the SIP-URI of the Contact header, sends a Success (200 OK) response preceded optionally by informational (1XX) response.

TPId: SIP_MG_TE_V_005

Status: Mandatory

Ref: 19.1.1 [1]

Purpose: Ensure that the IUT on receipt of an INVITE request including a method parameter set to "INVITE" in the SIP-URI of the Contact header, sends a Success (200 OK) response preceded optionally by informational (1XX) response.

- TPId:** SIP_MG_TE_V_006
- Status:** Mandatory
- Ref:** 8.2.1 [1]
- Purpose:** Ensure that the IUT on receipt of a request including a non-supported Method, sends a Method not allowed (405 Method Not Allowed) response including an Allow header that lists the set of method supported.
-
- TPId:** SIP_MG_TE_V_007
- Status:** Mandatory
- Ref:** 8.2.2 [1]
- Purpose:** Ensure that the IUT on receipt of an INVITE request including an unknown header, ignores them and sends a Success (200 OK) response preceded optionally by informational (1XX) response.
-
- TPId:** SIP_MG_TE_V_008
- Status:** Mandatory
- Ref:** 7.3.1 [1]
- Purpose:** Ensure that the IUT on receipt of an INVITE request including headers named with upper and lower cases, sends a Success (200 OK) response preceded optionally by informational (1XX) response.
-
- TPId:** SIP_MG_TE_V_009
- Status:** Mandatory
- Ref:** 7.3.1 [1]
- Purpose:** Ensure that the IUT on receipt of an INVITE request including headers set with values preceded by several leading white space and properly extended over multiple lines, sends a Success (200 OK) response preceded optionally by informational (1XX) response.
-
- TPId:** SIP_MG_TE_V_010
- Status:** Mandatory
- Ref:** 7.3.1 [1]
- Purpose:** Ensure that the IUT on receipt of an INVITE request including a Via header set with multiple values separated by a comma, sends a Success (200 OK) response preceded optionally by informational (1XX) response.
-
- TPId:** SIP_MG_TE_V_011
- Status:** Mandatory
- Ref:** 7.3.1 [1]
- Purpose:** Ensure that the IUT on receipt of an INVITE request including multiple Via headers, sends a Success (200 OK) response preceded optionally by informational (1XX) response.

TPId: SIP_MG_TE_V_012
Status: Mandatory
Ref: 7.3.1 [1]
Purpose: Ensure that the IUT on receipt of an INVITE request including a branch parameter named with upper and lower cases of Via header, sends a Success (200 OK) response preceded optionally by informational (1XX) response.

TPId: SIP_MG_TE_V_013
Status: Mandatory
Ref: 7.3.3 [1]
Purpose: Ensure that the IUT on receipt of an INVITE request including headers set with short names, sends a Success (200 OK) response preceded optionally by informational (1XX) response.

TPId: SIP_MG_TE_V_014
Status: Mandatory
Ref: 18.1.1 [1]
Purpose: Ensure that the IUT on receipt of a 65.535 bytes long INVITE request including session description parameters that it can accept, transported by UDP, sends a Success (200 OK) response, preceded optionally by informational (1XX) response.

TPId: SIP_MG_TE_V_015
Status: Mandatory
Ref: 7.5 [1]
Purpose: Ensure that the IUT, on receipt of a INVITE request over a stream-oriented (TCP) transport with several CRLF before the start-line, sends a Success (200 OK) response preceded optionally by informational (1XX) response.

5.4.4.2 Invalid Behaviour

TPId: SIP_MG_TE_I_001
Status: Mandatory
Ref: 7.1 [1]
Purpose: Ensure that the IUT on receipt of an INVITE request with SIP-version in lower case, sends a Success (200 OK) response preceded optionally by informational (1XX) response.

- TPId:** SIP_MG_TE_I_002
- Status:** Mandatory
- Ref:** 19.1.1 [1]
- Purpose:** Ensure that the IUT on receipt of an INVITE request including a maddr parameter in the From and To headers, ignores them and sends a Success (200 OK) response without maddr parameter, preceded optionally by informational (1XX) response.
-
- TPId:** SIP_MG_TE_I_003
- Status:** Mandatory
- Ref:** 19.1.1 [1]
- Purpose:** Ensure that the IUT on receipt of an INVITE request including header parameters in the SIP-URI of the From and To headers, ignores them and sends a Success (200 OK) response, preceded optionally by informational (1XX) response.
-
- TPId:** SIP_MG_TE_I_004
- Status:** Mandatory
- Ref:** 19.1.1 [1]
- Purpose:** Ensure that the IUT on receipt of an INVITE request including method parameters set to "CANCEL" in the SIP-URI of the From and To headers, ignores them and sends a Success (200 OK) response, preceded optionally by informational (1XX) response.
-
- TPId:** SIP_MG_TE_I_005
- Status:** Recommended
- Ref:** 21.4.1 [1]
- Purpose:** Ensure that the IUT on receipt of an INVITE request without Call-ID header sends a Bad Request (400 Bad Request) response.
-
- TPId:** SIP_MG_TE_I_006
- Status:** Mandatory
- Ref:** 7.3.2 [1], 20 [1], table 2 [1]
- Purpose:** Ensure that the IUT on receipt of an INVITE request including header field Retry-After, ignores it and sends a Success (200 OK) response, preceded optionally by informational (1XX) response.
-
- TPId:** SIP_MG_TE_I_007
- Status:** Recommended
- Ref:** 18.3 [1]
- Purpose:** Ensure that the IUT, on receipt of an INVITE request, while a message-oriented (UDP) transport is used, including a body part shorter than the length indicated in the Content-Length header field, sends a Bad Request (400 Bad Request) response.

TPId: SIP_MG_TE_I_008

Status: Recommended

Ref: 18.3 [1]

Purpose: Ensure that the IUT, on receipt of an INVITE request, while a message-oriented (UDP) transport is used, including a body part longer than the length indicated in the Content-Length header field, ignores extra bytes and sends a Success (200 OK) response, preceded optionally by informational (1XX) response.

5.4.5 Proxy

GroupSelection: IUT is a Proxy.

5.4.5.1 Valid Behaviour

TPId: SIP_MG_PR_V_001

Status: Mandatory

Ref: 19.1.1 [1]

Purpose: Ensure that the IUT on receipt of an INVITE request including escaped characters in the SIP-URI of the Contact header forwards the message.

TPId: SIP_MG_PR_V_002

Status: Mandatory

Ref: 19.1.1 [1]

Purpose: Ensure that the IUT on receipt of an INVITE request including escaped delimiters in the SIP-URI of the Contact header forwards the message.

TPId: SIP_MG_PR_V_003

Status: Mandatory

Ref: 19.1.1 [1]

Purpose: Ensure that the IUT on receipt of an INVITE request including non-understood uri-parameters in the SIP-URI of the Contact header forwards the message.

TPId: SIP_MG_PR_V_004

Status: Mandatory

Ref: 19.1.1 [1]

Purpose: Ensure that the IUT on receipt of an INVITE request including a header parameter in the SIP-URI of the Contact header forwards the message.

TPId: SIP_MG_PR_V_005

Status: Mandatory

Ref: 19.1.1 [1]

Purpose: Ensure that the IUT on receipt of an INVITE request including a method parameter set to "INVITE" in the SIP-URI of the Contact header forwards the message.

TPId: SIP_MG_PR_V_006

Status: Mandatory

Ref: 8.2.2 [1]

Purpose: Ensure that the IUT on receipt of an INVITE request including unknown header forwards the message without removing or modifying those fields.

TPId: SIP_MG_PR_V_007

Status: Mandatory

Ref: 7.3.1 [1]

Purpose: Ensure that the IUT on receipt of an INVITE request including headers named with upper and lower cases forwards the message.

TPId: SIP_MG_PR_V_008

Status: Mandatory

Ref: 7.3.1 [1]

Purpose: Ensure that the IUT on receipt of an INVITE request including headers set with values preceded by several leading white space and properly extended over multiple lines forwards the message.

TPId: SIP_MG_PR_V_009

Status: Mandatory

Ref: 7.3.1 [1], 10.46.4 [1]

Purpose: Ensure that the IUT on receipt of an INVITE request including a Via header set with multiple values separated by a comma forwards the message after having inserted its own Via header value without changing the order of these field values.

TPId: SIP_MG_PR_V_010

Status: Mandatory

Ref: 7.3.1 [1], 10.46.4 [1]

Purpose: Ensure that the IUT on receipt of an INVITE request including multiple Via headers forwards the message after having inserted its own Via header value but without changing the order of these fields.

TPId: SIP_MG_PR_V_011

Status: Mandatory

Ref: 7.3.1 [1]

Purpose: Ensure that the IUT on receipt of an INVITE request including a branch parameter named with upper and lower cases in Via header forwards the message.

TPId: SIP_MG_PR_V_012

Status: Mandatory

Ref: 7.2 [1]

Purpose: Ensure that the IUT after having forwarded an INVITE request, on receipt of a Success (299 OK) response with non-defined last two digits forwards the message.

TPId: SIP_MG_PR_V_013

Status: Mandatory

Ref: 7.2 [1]

Purpose: Ensure that the IUT after having forwarded an INVITE request, on receipt of a Success (200 PERFECT) response with an unknown reason phrase forwards the message.

TPId: SIP_MG_PR_V_014

Status: Mandatory

Ref: 7.3.3 [1]

Purpose: Ensure that the IUT on receipt of an INVITE request including headers set with short names forwards the message.

TPId: SIP_MG_PR_V_015

Status: Mandatory

Ref: 18.1.1 [1]

Purpose: Ensure that the IUT on receipt of a 65.535 bytes long INVITE request forwards the message.

TPId: SIP_MG_PR_V_016

Status: Mandatory

Ref: 7.5 [1]

Purpose: Ensure that the IUT, on receipt of a INVITE request over a stream-oriented (TCP) transport with several CRLF before the start-line, forwards the message.

5.4.5.2 Invalid Behaviour

TPId: SIP_MG_PR_I_001

Status: Mandatory

Ref: 7.1 [1]

Purpose: Ensure that the IUT on receipt of an INVITE request with SIP version in lower case forwards the message.

TPId: SIP_MG_PR_I_002

Status: Mandatory

Ref: 19.1.1 [1]

Purpose: Ensure that the IUT, on receipt of an INVITE request including a transport parameter in the From and To headers, ignores them and forwards the message.

TPId: SIP_MG_PR_I_003

Status: Mandatory

Ref: 19.1.1 [1]

Purpose: Ensure that the IUT, on receipt of an INVITE request including header parameters in the SIP-URI of the From and To headers, ignores them and forwards the message.

TPId: SIP_MG_PR_I_004

Status: Mandatory

Ref: 19.1.1 [1]

Purpose: Ensure that the IUT, on receipt of an INVITE request including method parameters set to "CANCEL" in the SIP-URI of the From and To headers, ignores them and forwards the message.

TPId: SIP_MG_PR_I_005

Status: Recommended

Ref: 21.4.1 [1]

Purpose: Ensure that the IUT, on receipt of an INVITE request without Call-Id header sends a Bad Request (400 Bad Request) response.

TPId: SIP_MG_PR_I_006

Status: Mandatory

Ref: 7.3.2 [1], 20 [1], table 2 [1]

Purpose: Ensure that the IUT on receipt of an INVITE request including header field Retry-After, ignores it and forwards the message.

TPId: SIP_MG_PR_I_007
Status: Recommended
Ref: 18.3 [1]
Purpose: Ensure that the IUT, on receipt of an INVITE request, while a message-oriented (UDP) transport is used, including a body part shorter than the length indicated in the Content-Length header field, sends a Bad Request (400 Bad Request) response.

TPId: SIP_MG_PR_I_008
Status: Recommended
Ref: 18.3 [1]
Purpose: Ensure that the IUT, on receipt of an INVITE request, while a message-oriented (UDP) transport is used, including a body part longer than the length indicated in the Content-Length header field, ignores extra bytes and forwards the message.

TPId: SIP_MG_PR_I_009
Status: Recommended
Ref: 18.3 [1]
Purpose: Ensure that the IUT, while a message-oriented (UDP) transport is used, on receipt of a Success (200 OK) response including a body part shorter than the length indicated in the Content-Length header field, discards it and does not forward it.

TPId: SIP_MG_PR_I_010
Status: Recommended
Ref: 18.3 [1]
Purpose: Ensure that the IUT, when an INVITE client transaction is in the Calling state while a message-oriented (UDP) transport is used, on receipt of a Success (200 OK) response including a body part longer than the length indicated in the Content-Length header field, ignores extra bytes and forwards it.

5.4.6 Redirect server

GroupSelection: IUT is a Redirect Server.

5.4.6.1 Valid Behaviour

TPId: SIP_MG_RD_V_001
Status: Mandatory
Ref: 19.1.1 [1]
Purpose: Ensure that the IUT, on receipt of an INVITE request including escaped characters in the SIP-URI of the Contact header, sends a 3XX redirection response to the caller.

- TPId:** SIP_MG_RD_V_002
- Status:** Mandatory
- Ref:** 19.1.1 [1]
- Purpose:** Ensure that the IUT, on receipt of an INVITE request including escaped delimiters in the SIP-URI of the Contact header, sends a 3XX redirection response to the caller.
-
- TPId:** SIP_MG_RD_V_003
- Status:** Mandatory
- Ref:** 19.1.1 [1]
- Purpose:** Ensure that the IUT, on receipt of an INVITE request including non-understood uri-parameters in the SIP-URI of the Contact header, sends a 3XX redirection response to the caller.
-
- TPId:** SIP_MG_RD_V_004
- Status:** Mandatory
- Ref:** 19.1.1 [1]
- Purpose:** Ensure that the IUT, on receipt of an INVITE request including a header parameter in the SIP-URI of the Contact header, sends a 3XX redirection response to the caller.
-
- TPId:** SIP_MG_RD_V_005
- Status:** Mandatory
- Ref:** 19.1.1 [1]
- Purpose:** Ensure that the IUT, on receipt of an INVITE request including a method parameter set to "INVITE" in the SIP-URI of the Contact header, sends a 3XX redirection response to the caller.
-
- TPId:** SIP_MG_RD_V_006
- Status:** Mandatory
- Ref:** 8.2.2 [1]
- Purpose:** Ensure that the IUT, on receipt of an INVITE request including an unknown header, sends a 3XX redirection response to the caller.
-
- TPId:** SIP_MG_RD_V_007
- Status:** Mandatory
- Ref:** 7.3.1 [1]
- Purpose:** Ensure that the IUT, on receipt of an INVITE request including headers named with upper and lower cases, sends a 3XX redirection response to the caller.

- TPId:** SIP_MG_RD_V_008
- Status:** Mandatory
- Ref:** 7.3.1 [1]
- Purpose:** Ensure that the IUT, on receipt of an INVITE request including headers set with values preceded by several leading white space and properly extended over multiple lines, sends a 3XX redirection response to the caller.
-
- TPId:** SIP_MG_RD_V_009
- Status:** Mandatory
- Ref:** 7.3.1 [1], 10.46.4 [1]
- Purpose:** Ensure that the IUT, on receipt of an INVITE request including a Via header set with multiple values separated by a comma, sends a 3XX redirection response including the received Via header values, without changing their order, to the caller.
-
- TPId:** SIP_MG_RD_V_010
- Status:** Mandatory
- Ref:** 7.3.1 [1], 10.46.4 [1]
- Purpose:** Ensure that the IUT, on receipt of an INVITE request including multiple Via headers, sends a 3XX redirection response including the received Via header values, without changing their order, to the caller.
-
- TPId:** SIP_MG_RD_V_011
- Status:** Mandatory
- Ref:** 7.3.1 [1]
- Purpose:** Ensure that the IUT, on receipt of an INVITE request including a branch parameter named with upper and lower cases in Via header, sends a 3XX redirection to the caller.
-
- TPId:** SIP_MG_RD_V_012
- Status:** Mandatory
- Ref:** 7.3.3 [1]
- Purpose:** Ensure that the IUT, on receipt of an INVITE request including headers set with short names, sends a 3XX redirection to the caller.
-
- TPId:** SIP_MG_RD_V_013
- Status:** Mandatory
- Ref:** 18.1.1 [1]
- Purpose:** Ensure that the IUT on receipt of a 65.535 bytes long INVITE request sends a 3XX redirection to the caller.

TPId: SIP_MG_RD_V_014
Status: Mandatory
Ref: 7.5 [1]
Purpose: Ensure that the IUT, on receipt of a INVITE request over a stream-oriented (TCP) transport with several CRLF before the start-line, sends a 3XX redirection to the caller.

5.4.6.2 Invalid Behaviour

TPId: SIP_MG_RD_I_001
Status: Mandatory
Ref: 7.1 [1]
Purpose: Ensure that the IUT, on receipt of an INVITE request with SIP version in lower case, sends a 3XX redirection response to the caller.

TPId: SIP_MG_RD_I_002
Status: Mandatory
Ref: 19.1.1 [1]
Purpose: Ensure that the IUT, on receipt of an INVITE request including a transport parameter in the From and To headers, ignores them and sends a 3XX redirection to the caller.

TPId: SIP_MG_RD_I_003
Status: Mandatory
Ref: 19.1.1 [1]
Purpose: Ensure that the IUT, on receipt of an INVITE request including header parameters in the SIP-URI of the From and To headers, ignores them and sends a 3XX redirection to the caller.

TPId: SIP_MG_RD_I_004
Status: Mandatory
Ref: 19.1.1 [1]
Purpose: Ensure that the IUT, on receipt of an INVITE request including method parameters set to "CANCEL" in the SIP-URI of the From and To headers, ignores them and sends a 3XX redirection to the caller.

TPId: SIP_MG_RD_I_005

Status: Recommended

Ref: 21.4.1 [1]

Purpose: Ensure that the IUT, on receipt of an INVITE request without Call-Id header sends a Bad Request (400 Bad Request) response.

TPId: SIP_MG_RD_I_006

Status: Mandatory

Ref: 7.3.2 [1], 20 [1], table 2 [1]

Purpose: Ensure that the IUT on receipt of an INVITE request including header field Retry-After, ignores it and sends a 3XX redirection to the caller.

TPId: SIP_MG_RD_I_007

Status: Recommended

Ref: 18.3 [1]

Purpose: Ensure that the IUT, on receipt of an INVITE request, while a message-oriented (UDP) transport is used, including a body part shorter than the length indicated in the Content-Length header field, sends a Bad Request (400 Bad Request) response.

TPId: SIP_MG_RD_I_008

Status: Recommended

Ref: 18.3 [1]

Purpose: Ensure that the IUT, on receipt of an INVITE request, while a message-oriented (UDP) transport is used, including a body part longer than the length indicated in the Content-Length header field, ignores extra bytes and sends a 3XX redirection to the caller.

History

Document history		
V1.1.1	August 2002	Publication
V2.1.1	October 2003	Publication