

TS 101 679 V1.1.1 (1999-07)

Technical Specification

**Digital Enhanced Cordless Telecommunications (DECT);
Broadband Integrated Services Digital Network (B-ISDN);
DECT/B-ISDN interworking**



Reference

DTS/DECT-030130 (fjo00icr.PDF)

Keywords

B-ISDN, DECT, interworking, profile, radio

ETSI

Postal address

F-06921 Sophia Antipolis Cedex - FRANCE

Office address

650 Route des Lucioles - Sophia Antipolis
Valbonne - FRANCE
Tel.: +33 4 92 94 42 00 Fax: +33 4 93 65 47 16
Siret N° 348 623 562 00017 - NAF 742 C
Association à but non lucratif enregistrée à la
Sous-Préfecture de Grasse (06) N° 7803/88

Internet

secretariat@etsi.fr
Individual copies of this ETSI deliverable
can be downloaded from
<http://www.etsi.org>
If you find errors in the present document, send your
comment to: editor@etsi.fr

Copyright Notification

No part may be reproduced except as authorized by written permission.
The copyright and the foregoing restriction extend to reproduction in all media.

© European Telecommunications Standards Institute 1999.
All rights reserved.

Contents

Intellectual Property Rights	6
Foreword	6
Introduction	6
1 Scope	7
2 References	7
3 Definitions, symbols and abbreviations	10
3.1 Definitions	10
3.2 Symbols	12
3.3 Abbreviations	12
3.3.1 DECT abbreviations	12
3.3.2 ISDN abbreviations	13
3.3.3 ISO 9646 abbreviations	13
4 Inter-working requirements	14
4.1 Reference configurations and interface	14
4.1.1 Reference Model	14
4.1.2 End system reference configuration	14
4.1.3 Interfaces	15
4.1.3.1 B-ISDN interfaces	15
4.1.3.2 Interfaces supported for a DECT end system	15
4.2 Protocol architecture models	15
4.3 Service requirements	16
4.3.1 Bearer service requirements	16
4.3.2 Interworking of bearer services	16
4.3.2.1 Circuit-mode 64 kbit/s Unrestricted, (ITU-T Recommendation I.231.1)	17
4.3.2.2 Circuit-mode Speech, (ITU-T Recommendation I.231.2)	17
4.3.2.3 Circuit-mode 3,1 kHz Audio, (ITU-T Recommendation I.231.3)	17
4.3.2.4 Other Services	17
4.3.3 End-to-end Compatibility of Information Transfer Attributes	17
4.3.3.1 Default Coding	17
4.3.3.2 ISDN Service Coding	18
4.3.4 Teleservice requirements	19
4.3.5 Supplementary service requirements	19
5 Inter-working mappings	19
5.1 Symbols for map columns	19
5.2 DFS C-plane IWU mappings	20
5.2.1 Call Control (CC) IWU procedures	20
5.2.1.1 Call establishment procedures	20
5.2.1.1.1 Outgoing call	20
5.2.1.1.2 Incoming call	23
5.2.1.1.3 Fall-back procedures	24
5.2.1.2 Call information procedures	24
5.2.1.3 Call release procedures	24
5.2.1.3.1 Call release initiated by the DPS	25
5.2.1.3.2 Call release initiated by the B-NT	25
5.2.2 Supplementary services IWU procedures	27
5.2.3 Other IWU procedures	27
5.2.3.1 Segmentation	27
5.2.3.2 Identity mapping procedures	27
5.2.4 Message mappings	27
5.2.4.1 Message Mapping - DECT to B-ISDN	27
5.2.4.1.1 CC-ALERTING - ALERTING	28

5.2.4.1.2	CC-CALL-PROC - CALL PROCEEDING	28
5.2.4.1.3	CC-CONNECT - CONNECT	29
5.2.4.1.4	CC_INFO (F-02) - INFORMATION (U2)	29
5.2.4.1.5	CC_INFO - INFORMATION	30
5.2.4.1.6	CC-RELEASE - RELEASE	30
5.2.4.1.7	CC-RELEASE-COM - RELEASE COMPLETE	31
5.2.4.1.8	CC-SETUP - SETUP	32
5.2.4.2	Message Mapping - B-ISDN to DECT	33
5.2.4.2.1	ALERTING - CC-ALERTING	33
5.2.4.2.2	CALL PROCEEDING - CC-CALL-PROC	34
5.2.4.2.3	CONNECT - CC-CONNECT	34
5.2.4.2.4	CONNECT ACKNOWLEDGE - CC-CONNECT-ACK	35
5.2.4.2.5	INFORMATION - CC-INFO	35
5.2.4.2.6	RELEASE - CC-RELEASE	36
5.2.4.2.7	RELEASE COMPLETE - CC-RELEASE-COM	36
5.2.4.2.8	SETUP - CC-SETUP	37
5.2.4.2.9	SETUP ACKNOWLEDGE - CC-SETUP-ACK	38
5.2.5	Information Element mapping	38
5.2.5.1	B-ISDN to DECT and DECT to B-ISDN	38
5.2.5.1.1	Basic Service - AAL parameters	38
5.2.5.1.2	Basic Service - ATM Traffic descriptor	38
5.2.5.1.3	Basic Service - Broadband Bearer Capability	38
5.2.5.1.3.1	DECT to B-ISDN	38
5.2.5.1.3.2	B-ISDN to DECT	38
5.2.5.1.4	Called Party Number - Called Party Number	39
5.2.5.1.5	Called Party Sub-address - Called Party Sub-address	39
5.2.5.1.6	Calling Party Number - Calling Party Number	39
5.2.5.1.7	IWU Attributes - AAL parameters	40
5.2.5.1.8	IWU Attributes - ATM Traffic descriptor	41
5.2.5.1.9	IWU Attributes - Broadband Bearer Capability	42
5.2.5.1.10	IWU Attributes - Broadband Low Layer Information	43
5.2.5.1.11	IWU to IWU - B-ISDN Information Element	44
5.2.5.1.12	Keypad - Called Party Number	44
5.2.5.1.13	Progress Indicator - Progress Indicator	44
5.2.5.1.14	Sending Complete - Broadband Sending Complete	45
5.2.6	Information Element Coding mapping	45
5.2.6.1	Coding standard - Coding standard	45
5.2.6.2	Configuration - User plane connection configuration	45
5.2.6.3	ID for Information Element - Information Element Identifier	45
5.2.6.4	Info Transfer Capability - AAL Subtype	46
5.2.6.5	Info Transfer Rate - CBR Rate	46
5.2.6.6	Info Transfer Rate - Peak Cell Rates	47
5.2.6.7	L2 Protocol ID - User Information Layer 2 Protocol	47
5.2.6.8	L3 protocol ID - User Information Layer 3 Protocol	48
5.2.6.9	Length of contents - Length of contents	48
5.2.6.10	Location - Location	49
5.2.6.11	Message type - Message type	50
5.2.6.12	Numbering Plan Identification - Numbering Plan Identification	51
5.2.6.13	Number Type - Type Of Number	51
5.2.6.14	Odd/even - Odd/Even Indicator	52
5.2.6.15	Portable Identity - Call Reference	52
5.2.6.16	Progress Description - Progress Description	53
5.2.6.17	Protocol Discriminator - Protocol Discriminator	53
5.2.6.18	Protocol Identifier Coding - Protocol Identifier Coding	54
5.2.6.19	Rate multiplier - Multiplier	54
5.2.6.20	Release Reason - Cause	55
5.2.6.20.1	DECT to B-ISDN	55
5.2.6.20.2	B-ISDN to DECT	56
5.2.6.21	Sub-address Type - Type Of Sub-Address	57
5.2.6.22	Transaction Identifier - Call Reference	57

5.2.6.22.1	Transaction Flag - Call reference Flag.....	57
5.2.6.22.2	Transaction Value - Call Reference	57
5.2.6.23	Transfer Mode - AAL Type.....	57
5.2.6.24	Transfer Mode - Bearer Class.....	58
5.2.6.25	Unit Rate - CBR rate	58
Annex A (informative): Inter-working state machine.....		59
A.1	IWU Call Control State Transition Diagram.....	59
A.2	IWU Call Control States.....	59
A.3	IWU Call Control Transition Procedures	59
Annex B (informative): DECT OVERLAP SENDING in B-ISDN NULL state		61
Bibliography		64
History.....		67

Intellectual Property Rights

IPRs essential or potentially essential to the present document may have been declared to ETSI. The information pertaining to these essential IPRs, if any, is publicly available for **ETSI members and non-members**, and can be found in SR 000 314: "*Intellectual Property Rights (IPRs); Essential, or potentially Essential, IPRs notified to ETSI in respect of ETSI standards*", which is available **free of charge** from the ETSI Secretariat. Latest updates are available on the ETSI Web server (<http://www.etsi.org/ipr>).

Pursuant to the ETSI IPR Policy, no investigation, including IPR searches, has been carried out by ETSI. No guarantee can be given as to the existence of other IPRs not referenced in SR 000 314 (or the updates on the ETSI Web server) which are, or may be, or may become, essential to the present document.

Foreword

This Technical Specification (TS) has been produced by ETSI Project Digital Enhanced Cordless Telecommunications (DECT).

Introduction

The present document specifies how Broadband Integrated Services Digital Network (B-ISDN) services are provided over the DECT air interface.

One of the main objectives is to describe how the B-ISDN services are mapped across the DECT air interface in a formal way, so that inter-operability of different manufacturers' equipment can be achieved.

1 Scope

The present document specifies how B-ISDN services can be accessed with a DECT terminal and describes the interworking between B-ISDN and the DECT end system.

The present document covers interworking between B-ISDN constant bit rate (Class A) services and the following DECT services:

- circuit mode 64 kbits/s unrestricted (ITU-T Recommendation I.231.1 [30]);
- circuit mode Speech (ITU-T Recommendation I.231.2 [31]);
- circuit mode 3,1 kHz Audio (ITU-T Recommendation I.231.3 [32]).

The DECT end system reference configuration is used where the DECT fixed system and the DECT portable system together form an end system with the behaviour of a B-ISDN Terminal Equipment (B-ISDN-TE).

Mobility management is outside the scope of the present document.

2 References

The following documents contain provisions which, through reference in this text, constitute provisions of the present document.

- References are either specific (identified by date of publication, edition number, version number, etc.) or non-specific.
- For a specific reference, subsequent revisions do not apply.
- For a non-specific reference, the latest version applies.
- A non-specific reference to an ETS shall also be taken to refer to later versions published as an EN with the same number.

- [1] ECMA TR/44 (1989): "An architectural framework for private networks".
- [2] EN 300 102-1: "Integrated Services Digital Network (ISDN); User-network interface layer 3; Specifications for basic call control".
- [3] EN 300 175-5: "Digital Enhanced Cordless Telecommunications (DECT); Common Interface (CI); Part 5: Network (NWK) layer".
- [4] EN 300 242: "Terminal Equipment (TE); Group 3 facsimile equipment".
- [5] EN 300 443-1: "Broadband Integrated Services Digital Network (B-ISDN); Digital Subscriber Signalling System No. two (DSS2) protocol; B-ISDN user-network interface layer 3 specification for basic call/bearer control; Part 1: Protocol specification [ITU-T Recommendation Q.2931 (1995), modified]".
- [6] ETS 300 080: "Integrated Services Digital Network (ISDN); ISDN lower layer protocols for telematic terminals".
- [7] ETS 300 081: "Integrated Services Digital Network (ISDN); Teletex end-to-end protocol over the ISDN".
- [8] ETS 300 111: "Integrated Services Digital Network (ISDN); Telephony 3,1 kHz teleservice; Service description".
- [9] ETS 300 112: "Integrated Services Digital Network (ISDN); Facsimile group 4 class 1 equipment on the ISDN; End-to-end protocols".

- [10] ETS 300 120: "Integrated Services Digital Network (ISDN); Service requirements for telefax group 4".
- [11] ETS 300 262: "Integrated Services Digital Network (ISDN); Syntax-based Videotex teleservice; Service description".
- [12] ETS 300 263: "Integrated Services Digital Network (ISDN); Telephony 7 kHz teleservice; Service description".
- [13] ETS 300 264: "Integrated Services Digital Network (ISDN); Videotelephony teleservice; Service description".
- [14] ETS 300 434-1: "Digital Enhanced Cordless Telecommunications (DECT); Integrated Services Digital Network (ISDN); DECT/ISDN interworking for end system configuration; Part 1: Interworking specification".
- [15] ETR 056: "Digital Enhanced Cordless Telecommunications (DECT); System description document".
- [16] GSM 04.06: "Digital cellular telecommunications system; Mobile Station; Base Station System (MS - BSS) interface Data Link (DL) layer specification".
- [17] GSM 04.08: "Digital cellular telecommunications system (Phase 2+); Mobile radio interface layer 3 specification".
- [18] ISO 1745 (1975): "Information processing; Basic mode control procedures for data communication systems".
- [19] ISO/IEC 4335 (1993): "Information technology; Telecommunications and information exchange between systems; High-level data link control (HDLC) procedures; Elements of procedures".
- [20] ISO/IEC 7776 (1995): "Information technology; Telecommunications and information exchange between systems; High-level data link control procedures; Description of the X.25 LAPB-compatible DTE data link procedures".
- [21] ISO/IEC 8208 (1995): "Information technology; Data communications; X.25 Packet Layer Protocol for Data Terminal Equipment".
- [22] ISO/IEC 8348 (1996): "Information technology; Open Systems Interconnection; Network Service Definition".
- [23] ISO/IEC 8473 (1996): "Information technology; Protocol for providing the connectionless-mode network service".
- [24] ISO/IEC 8802-2 (1998): "Information technology; Telecommunications and information exchange between systems; Local and metropolitan area networks; Specific requirements; Part 2: Logical link control".
- [25] ISO/IEC 8878 (1992): "Information technology; Telecommunications and information exchange between systems; Use of X.25 to provide the OSI Connection-mode Network Service".
- [26] ISO/IEC 9577 (1996): "Information technology; Protocol identification in the network layer".
- [27] ISO/IEC 9646-1 (1991): "Information Technology - Open System Interconnection - Conformance testing methodology and framework - Part 1: General concepts".
- [28] ISO/IEC 9646-3 (1991): "Information Technology - Open System Interconnection - Conformance testing methodology and framework - Part 3: The Tree and Tabular Combined Notation".
- [29] ITU-T Recommendation I.230 (1988): "Definition of bearer service categories".
- [30] ITU-T Recommendation I.231.1 (1988): "Circuit-mode 64 kbit/s unrestricted; 8 kHz structured bearer service".

- [31] ITU-T Recommendation I.231.2 (1988): "Circuit-mode 64 kbit/s, 8 kHz structured bearer service usable for speech information transfer".
- [32] ITU-T Recommendation I.231.3 (1988): "Circuit-mode 64 kbit/s, 8 kHz structured bearer service usable for 3,1 kHz audio information transfer".
- [33] ITU-T Recommendation I.241.2 (1988): "Teletex".
- [34] ITU-T Recommendation I.241.3 (1988): "Telefax 4".
- [35] ITU-T Recommendation I.241.5 (1988): "Videotex".
- [36] ITU-T Recommendation I.241.6 (1988): "Telex".
- [37] ITU-T Recommendation I.413 (1993): "B-ISDN user-network interface".
- [38] ITU-T Recommendation I.432 (1996): "B-ISDN User-Network Interface; Physical layer specification".
- [39] ITU-T Recommendation Q.921 (1997): "ISDN user-network interface; Data link layer specification".
- [40] ITU-T Recommendation Q.922 (1992): "ISDN data link layer specification for frame mode bearer services".
- [41] ITU-T Recommendation Q.2931 (1995): "Digital Subscriber Signalling System No. 2 (DSS 2); User-Network Interface (UNI) layer 3 specification for basic call/connection control".
- [42] ITU-T Recommendation T.70 (1993): "Network-independent basic transport service for the telematic services".
- [43] ITU-T Recommendation T.71 (1988): "Link access protocol balanced (LAPB) extended for half-duplex physical level facility".
- [44] ITU-T Recommendation V.42 (1996): "Error-correcting procedures for DCEs using asynchronous-to-synchronous conversion".
- [45] ITU-T Recommendation X.25 (1996): "Interface between Data Terminal Equipment (DTE) and Data Circuit-terminating Equipment (DCE) for terminals operating in the packet mode and connected to public data networks by dedicated circuit".
- [46] ITU-T Recommendation X.75 (1996): "Packet-switched signalling system between public networks providing data transmission services".
- [47] ITU-T Recommendation X.213 (1995): "Information technology; Open Systems Interconnection; Network service definition".
- [48] ITU-T Recommendation X.223 (1993): "Use of X.25 to provide the OSI connection-mode network service for ITU-T applications".
- [49] ITU-T Recommendation X.233 (1997): "Information technology; Protocol for providing the connectionless-mode network service: Protocol specification".
- [50] ITU-T Recommendation E.164 (1997): "The international public telecommunication numbering plan".
- [51] ITU-T Recommendation X.121 (1996): "International numbering plan for public data networks".
- [52] ITU-T Recommendation I.241.1: "Telephony".

3 Definitions, symbols and abbreviations

3.1 Definitions

For the purposes of the present document, the following terms and definitions apply:

bearer service: type of telecommunication service that provides a defined capability for the transmission of signals between user-network interfaces.

broadcast: simplex point-to-multipoint mode of transmission.

C-plane: control plane of the DECT protocol stacks, which contains all of the internal DECT protocol control, but may also include some external user information.

NOTE 1: The C-plane stack always contains protocol entities up to and including the network layer.

call: all of the NetWorK (NWK) layer processes involved in one network layer peer-to-peer association.

NOTE 2: Call may sometimes be used to refer to processes of all layers, since lower layer processes are implicitly required.

DECT Fixed System (DFS): logical grouping that contains all the functions between the DECT D reference point and the reference point on the fixed side of the DECT air interface.

NOTE 3: The DFS = Fixed radio Termination (FT) + (local network up to the fixed side ISDN reference point (including fixed side IWU)), see System Description Document (SDD).

DECT NetWork (DNW): network that uses the DECT air interface to interconnect a local network to one or more portable applications. The logical boundaries of the DECT network are defined to be at the top of the DECT network layer.

NOTE 4: A DNW is a logical grouping that contains one or more FTs plus their associated portable radio termination. The boundaries of the DECT network are not physical boundaries.

DECT Portable System (DPS): logical grouping that contains all the functions between the DECT D reference point and the user interface on the portable side of the DECT air interface.

NOTE 5: The DPS = PT + (PA (portable application)), see SDD.

End System (ES): logical grouping that contains application processes and supports telecommunication services.

NOTE 6: From the Open Systems Interconnection (OSI) point of view, end systems are considered as sources and sinks of information.

Fixed Part (DECT Fixed Part) (FP): physical grouping that contains all of the elements in the DECT network between the local network and the DECT air interface.

NOTE 7: A FP contains the logical elements of at least one FT, plus additional implementation specific elements.

Fixed radio Termination (FT): logical group of functions that contains all of the DECT processes and procedures on the fixed side of the DECT air interface.

NOTE 8: A FT only includes elements that are defined in the DECT CI standard. This includes radio transmission elements together with a selection of layer 2 and layer 3 elements.

Global NetWork (GNW): telecommunication network capable of offering a long distance telecommunication service.

NOTE 9: The term does not include legal or regulatory aspects, nor does it indicate if the network is a public or a private network.

incoming call: call received at a portable part.

inter-operability: capability of FPs and portable parts, that enable a portable part to obtain access to teleservices in more than one location area and/or from more than one operator (more than one service provider).

InterWorking Unit (IWU): unit that is used to interconnect sub-networks.

NOTE 10: The IWU will contain the inter-working functions necessary to support the required sub-network inter-working.

ISDN Access Profile (IAP): defined part of the DECT/ISDN inter-working standard that ensures inter-operability between FPs and portable parts for the access of ISDN services.

Local NetWork (LNW): telecommunication network capable of offering local telecommunication services.

NOTE 11: The term does not include legal or regulatory aspects, nor does it indicate if the network is a public network or a private network.

MAC Connection (connection): association between one source Medium Access Control (MAC) Multi-Bearer Control (MBC) entity and one destination MAC MBC entity. This provides a set of related MAC services (a set of logical channels), and it can involve one or more underlying MAC bearers.

outgoing call: call originating from a portable part.

paging: process of broadcasting a message from a DECT FP to one or more DECT portable parts.

NOTE 12: Different types of paging message are possible. For example, the {LCE_REQUEST-PAGE} message orders the recipient to respond with a call set-up attempt.

Portable Application (PA): logical grouping that contains all the elements that lie beyond the DECT network boundary on the portable side.

NOTE 13: The functions contained in the portable application may be physically distributed, but any such distribution is invisible to the DECT network.

Portable Part (DECT Portable Part) (PP): physical grouping that contains all elements between the user and the DECT air interface. Portable part is a generic term that may describe one or several physical pieces.

NOTE 14: A PP is logically divided into one portable termination plus one or more portable applications.

Portable radio Termination (PT): logical group of functions that contains all of the DECT processes and procedures on the portable side of the DECT air interface.

NOTE 15: A PT only includes elements that are defined in the DECT CI standard. This includes radio transmission elements (layer 1) together with a selection of layer 2 and layer 3 elements.

Public Access Profile (PAP): defined part of the DECT common interface standard (DECT CI) that ensures inter-operability between FPs and portable parts for public access services.

Radio Fixed Part (RFP): one physical sub-group of a FP that contains all the Radio End Points (REP) (one or more) that are connected to a single system of antennas.

segment: one of the pieces of data that is produced by the process of segmentation.

NOTE 16: In general, one segment only represents a portion of a complete message.

segmentation: process of partitioning one service data unit from a higher layer into more than one protocol data unit. The reverse process is assembly.

supplementary service: service that modifies or supplements a basic telecommunication service.

teleservice: type of telecommunication service that provides the complete capability, including terminal equipment functions, for communication between users, according to protocols that are established by agreement.

U-Plane: user plane of the DECT protocol stacks. This plane contains most of the end-to-end (external) user information and user control.

NOTE 17: The U-plane protocols do not include any internal DECT protocol control, and it may be null at the network layer and at the Data Link Control (DLC) layers for some services.

3.2 Symbols

For the purposes of the present document the following symbols apply:

<>	timer
<<>>	information element
{ }	message

3.3 Abbreviations

3.3.1 DECT abbreviations

For the purposes of the present document, the following DECT abbreviations apply:

CC	Call Control
CI	Common Interface
CISS	Call Independent Supplementary Services
CLMS	ConnectionLess Message Service
CLSS	ConnectionLess Supplementary Service
COMS	Connection Oriented Message Service
D	DECT reference point for end system
DECT	Digital European Cordless Telecommunications
DFS	DECT Fixed System
DLC	Data Link Control, Layer 2b of the DECT protocol stack
DPS	DECT Portable System
FP	Fixed Part, (see definitions)
FT	Fixed radio Termination, (see definitions)
IAP	ISDN Access Profile
IWU	InterWorking Unit, (see definitions)
LCE	Link Control Entity
MAC	Medium Access Control, Layer 2a of the DECT protocol stack
MM	Mobility Management, a NWK layer functional grouping
NWK	NetWorK, Layer 3 of the DECT protocol stack
PAP	Public Access Profile
PP	Portable Part
PT	Portable radio Termination, (see definition)
REP	Radio End Point, (see definitions)
RFP	Radio Fixed Part, (see definitions)
SDD	System Description Document
TI	Transaction Identifier

3.3.2 ISDN abbreviations

For the purposes of the present document, the following ISDN abbreviations apply:

3PTY	Three party
ADPCM	Adaptive Differential Pulse Code Modulation
AOC	Advice Of Charge
AOC-D	Advice Of Charge: charging information during the call
AOC-E	Advice Of Charge: charging information at the end of the call
AOC-S	Advice Of Charge: charging information at call set-up time
BC	Bearer Capability
B-NT	Network Termination for B-ISDN
CCBS	Completion of Calls to Busy Subscriber
CLIP	Calling Line Identification Presentation
CLIR	Calling Line Identification Restriction
COLP	Connected Line Identification Presentation
COLR	Connected Line Identification Restriction
CONF	Conference call, add-on
CUG	Closed User Group
CW	Call Waiting
DDI	Direct Dialling In
ECT	Explicit Call Transfer
FPH	Freephone
HLC	High Layer Compatibility
HOLD	Call Hold
ISDN	Integrated Services Digital Network
ISDN-TE	ISDN Terminal Equipment
LLC	Low Layer Compatibility
MCID	Malicious Call Identification
MSN	Multiple Subscriber Number
NT	Network Termination for ISDN
SS	Supplementary Services
SUB	Subaddressing
TP	Terminal Portability
UUS	User-to-User Signalling
UUS1	UUS service 1
UUS2	UUS service 2
UUS3	UUS service 3

3.3.3 ISO 9646 abbreviations

For the purposes of the present document, the following ISO/IEC 9646-1 [27] and ISO/IEC 9646-3 [28] abbreviation applies:

OSI	Open Systems Interconnection
-----	------------------------------

4 Inter-working requirements

4.1 Reference configurations and interface

4.1.1 Reference Model

The DECT end system reference configurations are used where the DECT Fixed System (DFS) and DPS together form an end system with the behaviour of a B-ISDN-TE.

Figure 1 shows the end system reference configuration:

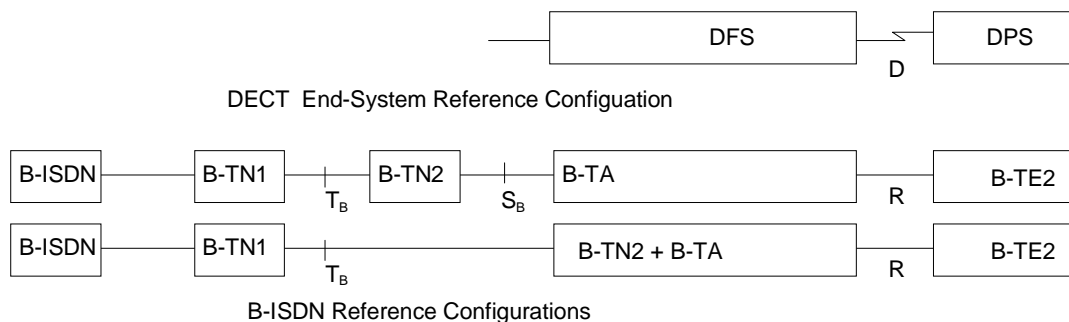

Figure 1: End System reference Configuration

The T_B reference point is always on the fixed side of the DECT air-interface (reference point D). In reference configurations where the S_B and T_B reference point don't coincide, S_B is always on the fixed side of the DECT air-interface.

As stated in subclause 4.1.2, for all B-ISDN user-network interfaces standardized in B-ISDN there shall be a corresponding physical interface. This means that if the scope of specification of B-ISDN inter-working to DECT is restricted to user-network interfaces, it is possible to assume that the B-ISDN reference point at the DFS always corresponds to a physical interface.

NOTE: This also means that the logical DFS is always bounded by two physical interfaces and therefore is also one or more physical entities.

4.1.2 End system reference configuration

The reference configurations describe the functional groupings of DECT and B-ISDN and their relationships via reference points. B-ISDN functional groupings and reference points are described in ITU-T Recommendation I.413 [37]. DECT functional groupings and reference points are described in the DECT System Description Document ETR 056 [15].

Figure 2 shows the mapping of the DECT logical reference configuration and B-ISDN reference configuration:

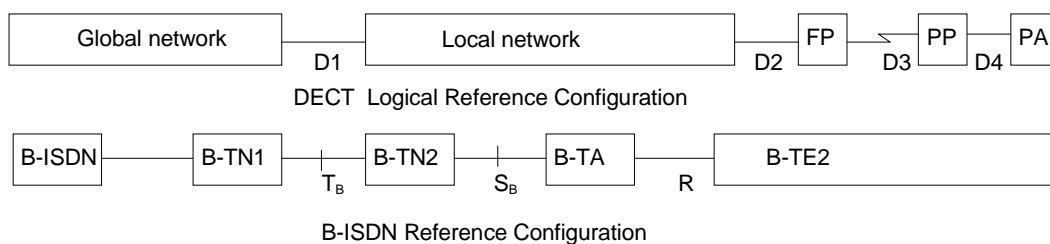

Figure 2: DECT logical reference configuration and B-ISDN reference configuration

In general, reference points may or may not correspond to a physical interface. The D2 and D4 are logical reference points, and can never align to physical boundaries. D3 always corresponds to a physical boundary. The D1 may correspond to a physical boundary. The S_B and T_B reference points always corresponds to a physical interface, according to ITU-T Recommendation I.413 [37]. However, the S_B and T_B reference points may coincide on the same physical interface.

4.1.3 Interfaces

4.1.3.1 B-ISDN interfaces

This inter-working specification is based on the B-ISDN user-network interface standard, EN 300 443-1 [5].

Furthermore this inter-working specification is based on the B-ISDN specifications for bearer services and the generic and service specific supplementary service specifications, which apply at the S_B/T_B reference point.

4.1.3.2 Interfaces supported for a DECT end system

The B-ISDN interfaces that are assumed to be supported by the DFS at the S_B and T_B reference points of the reference configuration, are defined in ITU-T Recommendation I.432 [38] (155 520 kbit/s and 622 080 kbit/s).

4.2 Protocol architecture models

Protocol architecture models are used to describe the protocol interactions at control plane (C-plane) and user-plane (U-plane) of the DFS and DPS. The concept of the protocol architecture model is based on ETR 056 [15] and therefore ECMA TR/44 [1]. The protocol architecture model also shows the location of the IWU.

NOTE 1: The IWU will contain the inter-working functions necessary to support the required sub-network inter-working.

NOTE 2: The IWUs, in the context of DECT, interconnect the FT at the fixed side to the attached sub-network.

The protocol architecture model for the end system configuration is based on full termination of the whole B-ISDN layer protocol in the DFS. The IWU in the DFS provides the mapping of the B-ISDN layer 3.

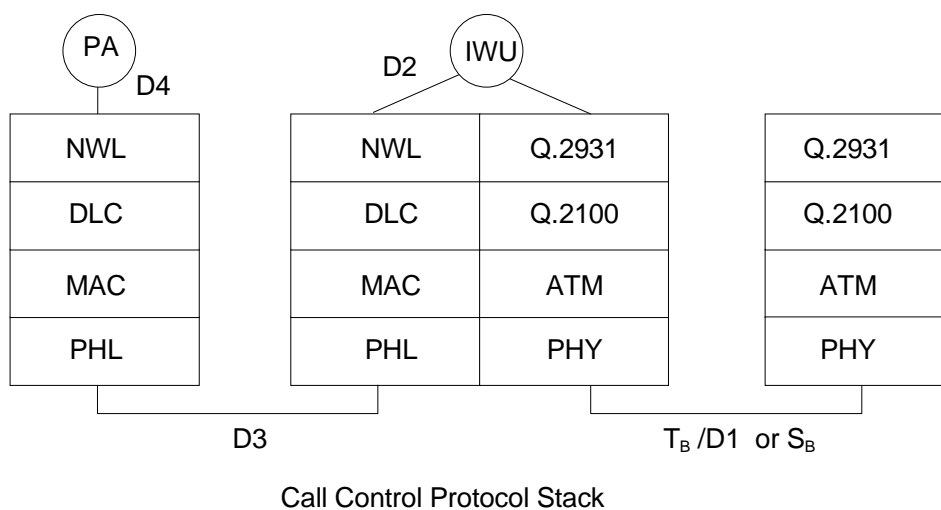

Figure 3: Call Control Protocol Stack

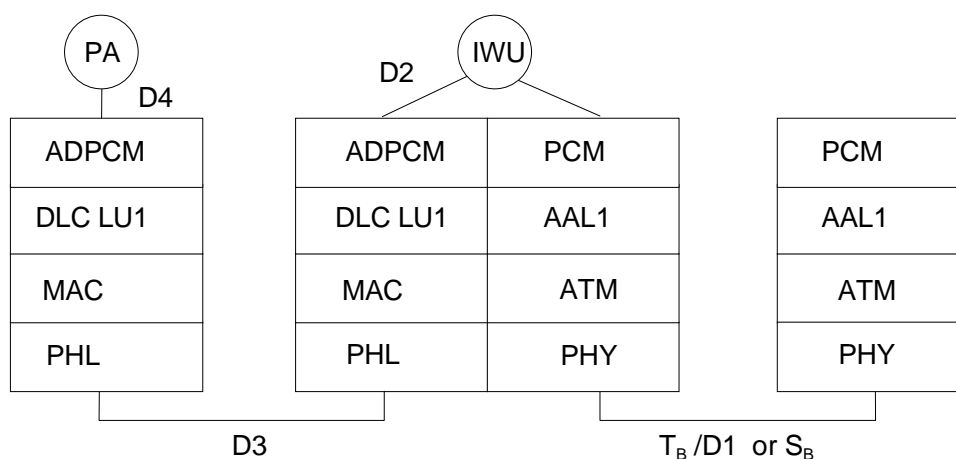

Figure 4: User Plane Protocol Stack: Basic Speech Example

4.3 Service requirements

4.3.1 Bearer service requirements

The present document covers interworking between B-ISDN constant bit rate (class A) services and the following DECT services:

- circuit mode 64 kbits/s unrestricted (ITU-T Recommendation I.231.1 [30]);
- circuit mode Speech (ITU-T Recommendation I.231.2 [31]);
- circuit mode 3,1 kHz Audio (ITU-T Recommendation I.231.3 [32]).

4.3.2 Interworking of bearer services

Bearer services, in DECT and B-ISDN respectively, are identified by the information transfer attributes according to ITU Recommendation I.230 [29]:

- 1) information transfer mode;
- 2) information transfer rate;
- 3) information transfer capability;
- 4) structure;
- 5) establishment of communication;
- 6) symmetry;
- 7) communication configuration;

and interworking is specified on the basis of these information transfer attributes. The interworking covers the following Class A ISDN services.

4.3.2.1 Circuit-mode 64 kbit/s Unrestricted, (ITU-T Recommendation I.231.1)

Information Transfer Attributes and values of attributes of the circuit-mode 64 kbit/s unrestricted, 8 kHz structured bearer service category.

Table 1

1	Information transfer mode:	circuit (B-ISDN Class A)
2	Information transfer rate:	64 kbit/s
3	Information transfer capability:	unrestricted
4	Structure:	8 kHz integrity
5	Establishment of communication:	demand
6	Symmetry:	bi-directional symmetric
7	Communication configuration:	point-to-point

4.3.2.2 Circuit-mode Speech, (ITU-T Recommendation I.231.2)

Information Transfer Attributes and values of attributes of the circuit-mode 64 kbit/s 8 kHz structured bearer service category usable for speech information transfer.

Table 2

1	Information transfer mode:	circuit (B-ISDN Class A)
2	Information transfer rate:	64 kbit/s
3	Information transfer capability:	speech
4	Structure:	8 kHz integrity
5	Establishment of communication:	demand
6	Symmetry:	bi-directional symmetric
7	Communication configuration:	point-to-point

4.3.2.3 Circuit-mode 3,1 kHz Audio, (ITU-T Recommendation I.231.3)

Information Transfer Attributes and values of attributes of the circuit-mode 64 kbit/s, 8 kHz structured bearer service category usable for 3,1 kHz audio information transfer.

Table 3

1	Information transfer mode:	circuit (B-ISDN Class A)
2	Information transfer rate:	64 kbit/s
3	Information transfer capability:	3,1 kHz audio
4	Structure:	8 kHz integrity
5	Establishment of communication:	demand
6	Symmetry:	bi-directional symmetric
7	Communication configuration:	point-to-point

4.3.2.4 Other Services

For further study.

4.3.3 End-to-end Compatibility of Information Transfer Attributes

4.3.3.1 Default Coding

DECT to B-ISDN: If the <<BASIC SERVICE>> information element in the DECT set-up contains "default set-up attributes", the BCOB-A in <<BROADBAND-BEARER-CAPABILITY>> and the "AAL for voice" in the <<ATM parameters>> shall be used in the B-ISDN set-up message.

B-ISDN to DECT: If the <<BROADBAND-BEARER-CAPABILITY>> contains BCOB-A and the <<ATM parameters>> is absent or contains "AAL for voice", the <<BASIC SERVICE>> information element contains shall be set to "default set-up attributes" in the DECT set-up message.

Table 4

Basic speech service	DECT Default coding for basic speech (EN 300 175-5 [3] annex E)	B-ISDN Default coding for basic speech (EN 300 443-1 [5] annex E)
Information transfer attributes	Basic service (see note 1)	BB Bearer-capability, ATM-Traffic attributes, AAL parameters
Information transfer mode	-----	bearer class: BCOB-A
Information transfer rate	-----	peak cell rate: "200 cells/sec" (see note 2)
Information transfer capability	-----	AAL type: "AAL for voice"
Structure	-----	----
Establishment of communication	-----	----
Symmetry	-----	forward = backward peak cell rate
Communication configuration	-----	"point-to-point"
NOTE 1: No IWU attributes allowed for basic speech.		
NOTE 2: Based on an AAL type 1 payload of 40 bytes. With a payload of 47, the value is 171 cells/sec as in annex E/ITU-T Recommendation Q.2931 [41].		

4.3.3.2 ISDN Service Coding

DECT to B-ISDN: If the <<IWU-to-IWU>> information element in the DECT set-up contains the N-ISDN compatibility information element BC, then the B-ISDN set-up shall be with a N-ISDN service. The BC, LLC and HLC contained in the <<IWU-to-IWU>> shall be mapped to N-BC, N-LLC and N-HLC in the B-ISDN set-up message.

B-ISDN to DECT: If the B-ISDN set-up contains the N-ISDN compatibility information element N-BC, the N-ISDN compatibility information element N-BC, N-LLC and N-HLC in the B-ISDN set-up shall be mapped to <<IWU-to-IWU>> information element in the DECT set-up message.

Table 5

N-ISDN service	DECT	B-ISDN
Information transfer attributes	IWU-ATTRIBUTES, IWU-TO-IWU (see note)	BB Bearer-capability, ATM-Traffic attributes, N-BC
Information transfer mode	Information transfer mode	Bearer class, N-BC
Information transfer rate	Information transfer rate	peak cell rate, N-BC
Information transfer capability	Information transfer capability	N-BC
Structure	Structure	N-BC
Establishment of communication	Establishment of communication	N-BC
Symmetry	Symmetry	forward/backward peak cell rates, N-BC
Communication configuration	Communication configuration	User Plane Communication configuration, N-BC
NOTE: The complete N-BC information element will also be contained in the IWU-TO-IWU information element.		

4.3.4 Teleservice requirements

This inter-working specification covers the following teleservices:

- 3,1 kHz telephony, ITU-T Recommendation I.241.1 [52], ETS 300 111 [8];
- 7 kHz telephony, ETS 300 263 [12];
- videotelephony (in other terms: audio-visual teleservices, narrow band visual telephone systems), ETS 300 264 [13];
- telematic services:
 - teletex, ITU-T Recommendation I.241.2 [33], ETS 300 080 [6], and ETS 300 081 [7];
 - telefax group 4, ITU-T Recommendation I.241.3 [34], ETS 300 080 [6], ETS 300 112 [9], and ETS 300 120 [10];
 - syntax based videotex, ITU-T Recommendation I.241.5 [35], ETS 300 080 [6], and ETS 300 262 [11];
 - telex, ITU-T Recommendation I.241.6 [36].

NOTE 1: Presently the telex service may indirectly be accessed via the teletex service if teletex service providers support service inter-working by inter-working facilities. Specifications for the direct support of the telex service in the ISDN environment do not exist at ETSI nor are under discussion. Therefore the telex service is not further regarded here.

NOTE 2: Currently, only the 3,1 kHz telephony teleservice is fully specified in the basic DECT standard.

There are a lot of applications which are not standardized as services but use ISDN bearer services. Such applications include voice band data transmission, (e.g. group 3 facsimile (EN 300 242 [4]), data transmission via modems supported by terminal adapters) and digital data transmission. Applications such as these may have specific service requirements.

4.3.5 Supplementary service requirements

Supplementary services are for further study. For further details refer to ETS 300 434-1 [14].

5 Inter-working mappings

5.1 Symbols for map columns

The Map Status column shall be interpreted as follows:

- M for mandatory to map (the message, information element or coding is required to be mapped between the two standards if previously received);
- O for optional to map (Boolean - the message, information element or coding may be mapped between the two standards if previously received, but it shall be done as described);
- I for out-of-scope (the message, information element or coding may be mapped between the two standards if previously received, but it is irrelevant how it is done and is not subject for testing);
- X for prohibited or excluded to map (the message, information element or coding may be allowed to be used in the standard/standards but it is not allowed to map between the two standards);
- N/A or -(dash) for not applicable to map (logical impossible to map the message, information element or coding between the two standards);
- C for conditional to map (the message, information element or coding mapping depends on the selection of other optional and/or conditional items);

- G for generated (the message, information element or coding must be generated by the interworking function).

NOTE: The symbol '----' means that there is no message, information element or coding specified in this column.

5.2 DFS C-plane IWU mappings

5.2.1 Call Control (CC) IWU procedures

5.2.1.1 Call establishment procedures

Handling call collision is an implementation option and is therefore outside the scope of the present document.

5.2.1.1.1 Outgoing call

Upon receipt of a MNCC-SETUP-ind primitive the inter-working unit at the DFS (DFS-IWU) shall analyse the contents of the {CC-SETUP} message from the CC entity at the DPS side (DPS-CC). Depending on the information element <<CALLED-PARTY-NUMBER>> the DFS-IWU has to take different action (1 and 2):

- 1) <<CALLED-PARTY-NUMBER>> included in the {CC-SETUP}.

The outgoing call procedure with <<CALLED-PARTY-NUMBER>> information element included in the {CC-SETUP} is shown in figure 5.

In the case the {CC-SETUP} contains <<CALLED-PARTY-NUMBER>> with or without <<SENDING-COMPLETE>> then the DFS-IWU shall interpret the dialling as finished and therefore map the {CC-SETUP} into {SETUP} as described in subclause 5.2.4.1, Item No. 11. The DECT <<CALLED PARTY NUMBER>> shall always be mapped into B-ISDN <<CALLED PARTY NUMBER>> and also <<SENDING-COMPLETE>> information element shall be included in the B-ISDN message.

If the B-NT replies with {CALL-PROC}, {ALERTING} and/or {CONNECT} as responses to {SETUP}, then the message(s) shall be mapped to correspondent DECT messages as described in subclause 5.2.4.2, Item Nos. 2, 1, and 3. {CC-CALL-PROC}, {CC-ALERTING} and {CC-CONNECT} shall never be sent before their peer B-ISDN messages have been received. When a {CONNECT} message is received, then the DFS may send a {CONNECT-ACK} back to the network.

When the DFS-CC is in state F-03 or F-04 the DFS-IWU shall map all received {CC-INFO} messages into B-ISDN as described in subclause 5.2.4.1, Item No. 5.

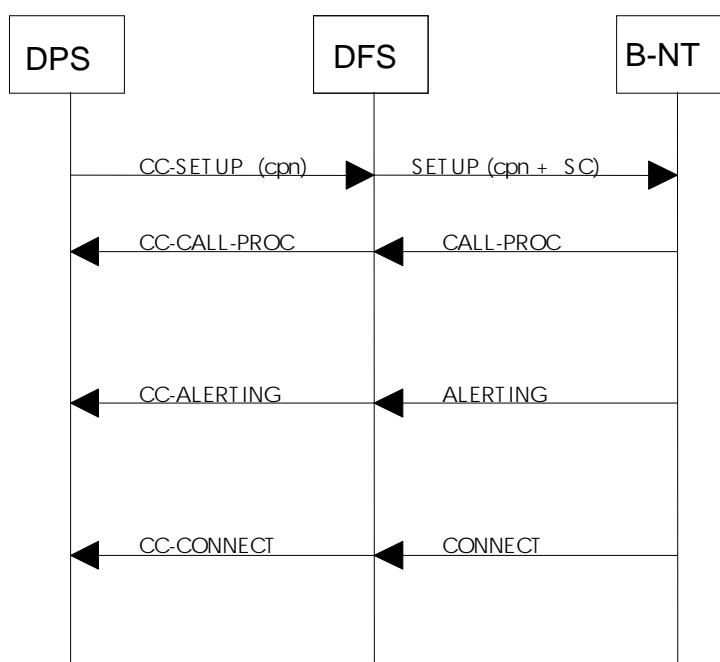

NOTE: cpn = <<CALLED-PARTY-NUMBER>> and SC = <<SENDING-COMPLETE>>.

Figure 5: Outgoing call procedure with <<CALLED-PARTY-NUMBER>> included in the {CC-SETUP}

- 2) No <<CALLED-PARTY-NUMBER>> included in the {CC-SETUP}. Dialling in {CC-INFO} in DECT OVERLAP SENDING state.

If the {CC-SETUP} does not contain <<CALLED-PARTY-NUMBER>> then the DFS-IWU shall either map the {CC-SETUP} into {SETUP} as described in subclause 5.2.4.1, Item No. 11 or issue a MNCC-SETUP-ACK-req primitive and this shall result in a {CC-SETUP-ACK} message being sent back to the DPS.

- case a) {SETUP} is sent into B-ISDN;
 case b) {CC-SETUP-ACK} is sent back to DPS.

In the error condition case when the {CC-SETUP} does not contain <<CALLED-PARTY-NUMBER>> but does contain <<SENDING-COMPLETE>> then the DFS-IWU shall reject the {CC-SETUP} by respond with MNCC-REJECT-req primitive and this shall result in a {CC-RELEASE-COM} message being sent to the DPS.

- 1) {SETUP} is sent into B-ISDN.

The outgoing call procedures with dialling information in DECT and B-ISDN OVERLAP SENDING state are shown in figure 6 and figure 7.

The DFS may receive a {SETUP-ACK} message from the B-NT. In that case, the DFS shall initiate MNCC-SETUP-ACK-req and map the {SETUP-ACK} into a {CC-SETUP-ACK} a described in subclause 5.2.4.2, Item No. 10. The DFS then has to wait for dialling information in one or more {CC-INFO}. The dialling information can be either in one or more <<KEYPAD>> or in one <<CALLED-PARTY-NUMBER>> information element.

If <<CALLED-PARTY-NUMBER>> information element is used for dialling information, it shall immediately be mapped into B-ISDN <<CALLED-PARTY-NUMBER>> and also <<SENDING-COMPLETE>> information element shall be included in the {INFORMATION} message. The mapping from {CC-INFO} to {INFORMATION} shall be done as described in subclause 5.2.4.1, Item No. 5.

If <<KEYPAD>> information elements are used for dialling information, then the DFS-IWU shall map the <<KEYPAD>> into <<CALLED-PARTY-NUMBER>> in a {INFORMATION} message. The DFS-IWU shall only map those keys which it can not distinguish to be non-dialling information, i.e. map by default unknown (for the DFS-IWU) keys to <<CALLED-PARTY-NUMBER>>. The mapping from {CC-INFO} to {INFORMATION} shall be done as described in subclause 5.2.4.1, Item No. 5.

If the B-NT replies with {CALL-PROC}, {ALERTING} and/or {CONNECT} as responses to {SETUP} or as a result of overlap sending, then the message(s) shall be mapped to corresponding DECT messages as described in subclause 5.2.4.2, Items No. 2, 1, and 3. {CC-CALL-PROC}, {CC-ALERTING} and {CC-CONNECT} shall never be sent before their peer B-ISDN messages have been received. When a {CONNECT} message is received, then the DFS may send a {CONNECT-ACK} back to the network.

If the B-NT replies with {RELEASE} or {RELEASE-COM} as a response to the {SETUP}, then the DFS-IWU shall apply the appropriate release procedures defined in subclause 5.2.1.3.

When the DFS-CC is in state F-03 or F-04 the DFS-IWU may map all received {CC-INFO} messages into B-ISDN as described in subclause 5.2.4.1, Item No. 5.

Upon receipt of a {INFORMATION} message from the B-NT during establishment then the DFS-IWU may map it into a {CC-INFO} as described in subclause 5.2.4.2, Item No. 5. The mapping of {INFORMATION} in B-ISDN OVERLAP SENDING state is mandatory and shall be done as described in subclause 5.2.4.2, Item No. 14.

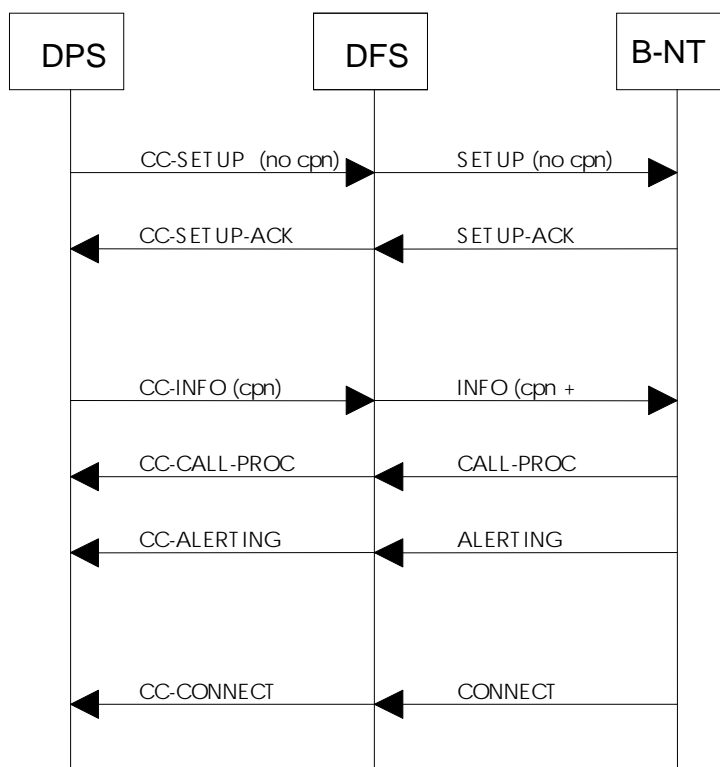

NOTE: cpn = <<CALLED-PARTY-NUMBER>> and SC = <<SENDING-COMPLETE>>.

Figure 6: The DPS sends <<CALLED-PARTY-NUMBER>> in DECT and B-ISDN OVERLAP SENDING state (case a)

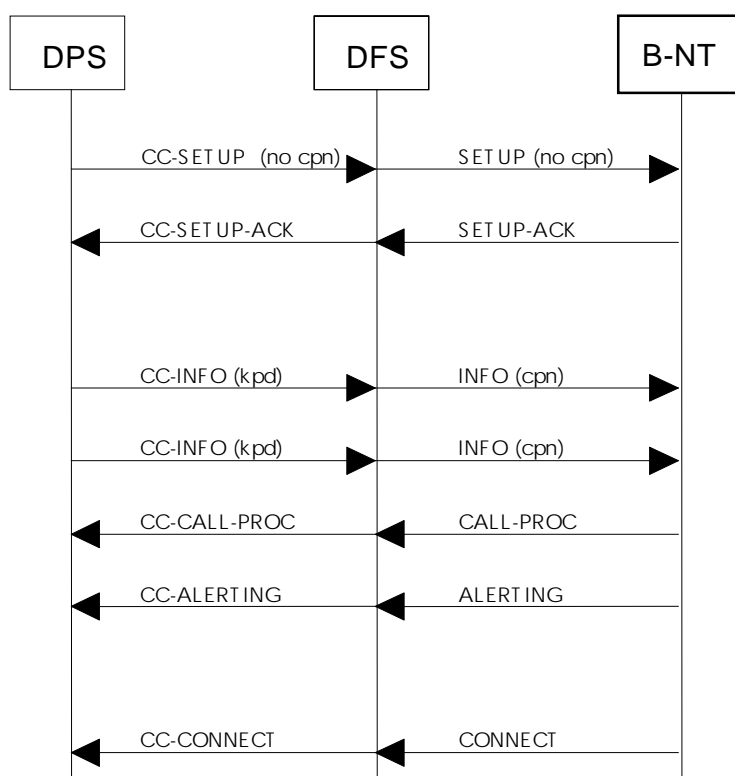

NOTE: cpn = <<CALLED-PARTY-NUMBER>> and kpd = <<KEYPAD>> with dialling information.

Figure 7: The DPS sends <<KEYPAD>> in DECT and B-ISDN OVERLAP SENDING state (case a)

b) {CC-SETUP-ACK} is sent back to the DPS.

Handling of {CC-SETUP-ACK} by the DFS is an implementation option and is therefore outside the scope of the present document. For further information, see annex E.

5.2.1.1.2 Incoming call

The incoming call procedure is shown in figure 8.

Upon receipt of a {SETUP} message the inter-working unit at the DFS (DFS-IWU) shall issue an MNCC-SETUP-req primitive to the DFS-CC. The {SETUP} shall be mapped into {CC-SETUP} as described in subclause 5.2.4.2. The DFS shall send a {CALL-PROC} message back to the B-NT.

If the DPS replies with {CC-ALERTING} and/or {CC-CONNECT} as responses to the {CC-SETUP}, then the message(s) shall be mapped to corresponding B-ISDN messages as described in subclause 5.2.4.1.

If the DPS replies with {CC-RELEASE-COM} as a response to the {CC-SETUP} message, then the DFS-IWU shall apply the appropriate release procedure defined in subclause 5.2.1.3.

Upon receipt of a {CONNECT-ACK} message from the B-NT as a confirmation of the {CONNECT}, the DFS-IWU shall issue a MNCC-CONNECT-res primitive and map the {CONNECT-ACK} message into a {CC-CONNECT-ACK} message as described in subclause 5.2.4.2, Item No. 4.

When the DFS-CC is in state F-07, the DFS-IWU may map all received {CC-INFO} messages into an {INFORMATION} message as described in subclause 5.2.4.1, Item No. 5.

Upon receipt of a {INFORMATION} message from the B-NT during establishment then the DFS-IWU may map it into a {CC-INFO} as described in subclause 5.2.4.2, Item No. 5.

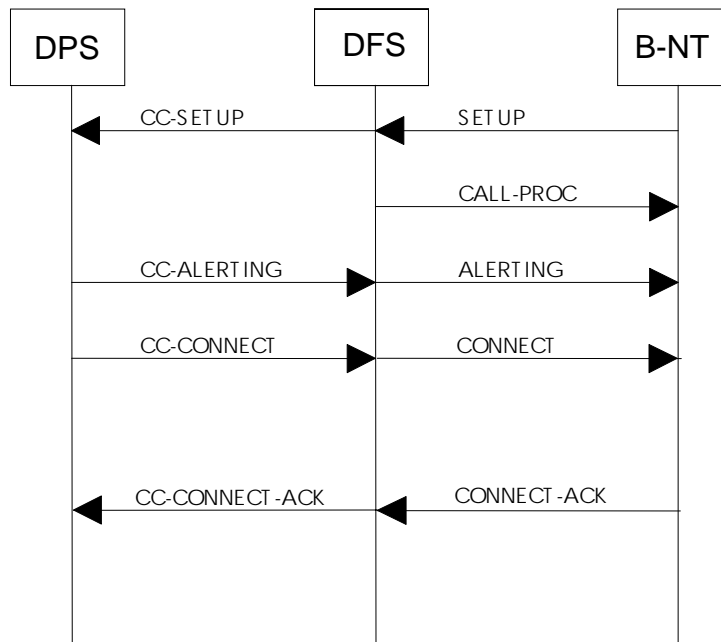

NOTE: The DFS shall send {CALL-PROC} because the timer in the network should not time out.

Figure 8: Incoming call

5.2.1.1.3 Fall-back procedures

The support of the N-ISDN fall-back procedures in B-ISDN is outside the scope of the present document.

5.2.1.2 Call information procedures

The call information procedures are shown in figure 9.

The DFS-IWU may map all received {CC-INFO} message into an {INFORMATION} message as described in subclause 5.2.4.1, Item No. 5.

Upon receipt of a {INFORMATION} message from the B-NT during active state the DFS-IWU may map it into a {CC-INFO} message as described in subclause 5.2.4.2, Item No. 5.

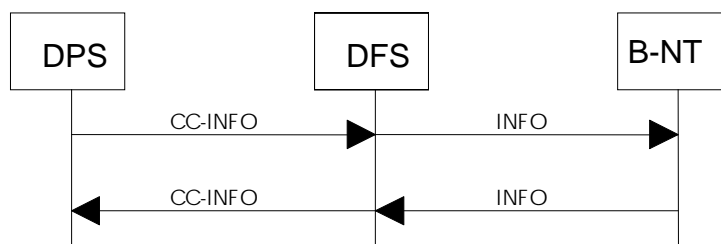

Figure 9: Call Information Procedure

5.2.1.3 Call release procedures

In case the B-ISDN network mandate a 'cause' value and DECT does not provide a valid reason (if present) then 'cause' value shall be set to cause #127 by default.

5.2.1.3.1 Call release initiated by the DPS

The call release procedures initiated by the DPS can be done either with {CC-RELEASE} (case 1) or with {CC-RELEASE-COM} (case 2).

case 1) {CC-RELEASE} is used for call release:

- upon receipt of a MNCC-RELEASE-ind primitive the DFS-IWU shall map the {CC-RELEASE} into {RELEASE} as described in subclause 5.2.4.1, Item No. 6;
- when the DFS-IWU later on receives a {RELEASE-COM} message, it shall map the {RELEASE} message into a {CC-RELEASE-COM} message as described in subclause 5.2.4.2.

The normal call release initiated by the DPS is shown in figure 10.

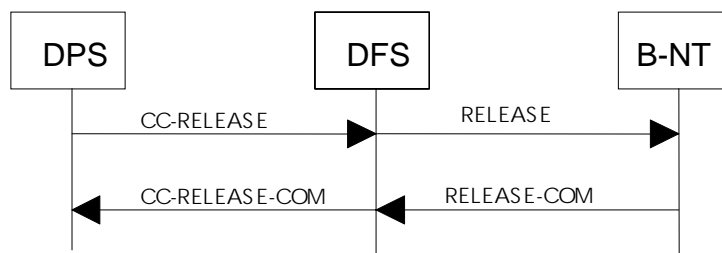

Figure 10: Normal Release initiated by the DPS

case 2) {CC-RELEASE-COM} is used for call release:

- upon receipt of a {CC-RELEASE-COM} message the DFS-IWU shall map the {CC-RELEASE-COM} message to a {RELEASE-COM} message according to subclause 5.2.4.1.

The DECT abnormal call release initiated by the DPS is shown in figure 11.

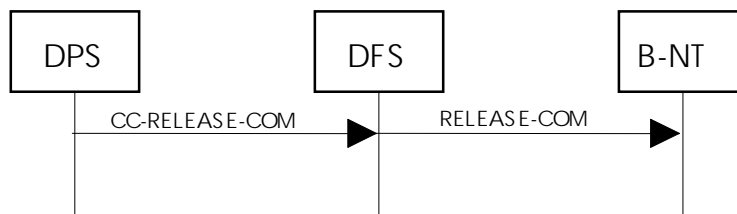

Figure 11: Abnormal call release initiated by the DPS

5.2.1.3.2 Call release initiated by the B-NT

The call release procedures initiated by the NT can be done with {RELEASE} (case 1) or with {RELEASE-COM} (case 2).

case 1) {DISCONNECT} is used for call release:

- upon receipt of a {DISCONNECT} message the DFS-IWU shall issue a MNCC-RELEASE-req and this shall result in a {CC-RELEASE} message. The DFS-IWU shall map the {DISCONNECT} message into a {CC-RELEASE} message as described in subclause 5.2.4.1, Item No. 8. The DFS starts the timer <CC.02>;
- the information elements of the {DISCONNECT} message shall be mapped to information elements of a {CC-RELEASE} message according to the table in subclause 5.2.4.1.8;
- upon receipt of a {CC-RELEASE-COM} message the DFS shall map the {CC-RELEASE-COM} into {RELEASE} as described in subclause 5.2.4.2, Item No. 12;

- if the timer <CC.02> expires before the receipt of a {CC-RELEASE-COM} message, the DFS-IWU shall immediately initiate a MNCC-RELEASE-res primitive and this shall result in a {CC-RELEASE-COM} message. The DFS-IWU shall also initiate a {RELEASE} to the NT. The response from the NT is {RELEASE-COM} and the DFS-IWU shall not map this finalizing message.

The normal call release using {DISCONNECT} initiated by the NT is shown in figure 12.

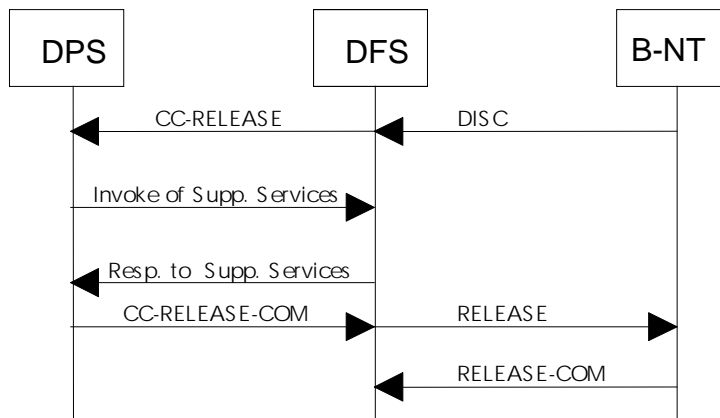

NOTE 1: The content of the {DISCONNECT} message is mapped to the content of the {CC-RELEASE} message. The message type DISCONNECT is mapped to a <<IWU-TO-IWU>> information element in the {CC-RELEASE} message.

NOTE 2: The user can invoke some ISDN supplementary services using a {FACILITY} message. It is however his responsibility to await a returning message before completing the clearing operation.

Figure 12: Where NT initiate normal call release with {DISCONNECT} (case 1)

case 1) {RELEASE} is used for call release;

- upon receipt of a {RELEASE} message the DFS shall map the {RELEASE} into {CC-RELEASE} message as described in subclause 5.2.4.2, Item No. 7;
- upon receipt of a {CC-RELEASE-COM} message the DFS shall map the {CC-RELEASE-COM} into {RELEASE-COM} as described in subclause 5.2.4.1, Item No. 7.

The call release using {RELEASE} initiated by the NT is shown in figure 13.

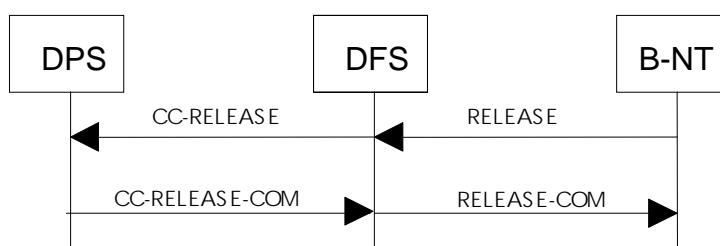

Figure 13: where NT initiate normal call release with {RELEASE} (case 2)

Case 2) {RELEASE-COM} is used for call release:

- upon receipt of a {RELEASE-COM} message the DFS-IWU shall map the {RELEASE-COM} to {CC-RELEASE-COM} according to subclause 5.2.4.2, Item No. 8.

The call release initiated by the NT is shown in the following figure 14.

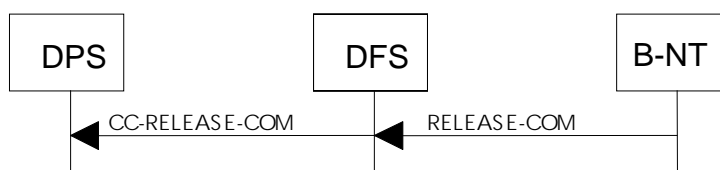

Figure 14: Abnormal call release initiated by the NT

5.2.2 Supplementary services IWU procedures

Supplementary services are for further study. For further details refer to ETS 300 434-1 [14].

5.2.3 Other IWU procedures

5.2.3.1 Segmentation

5.2.3.2 Identity mapping procedures

5.2.4 Message mappings

5.2.4.1 Message Mapping - DECT to B-ISDN

Table 6

Item No	DECT message	B-ISDN message	Ref.	Map Status	NOTE
1	CC-ALERTING	ALERTING	5.2.4.1.1	M	
2	CC-CALL-PROC	CALL PROCEEDING	5.2.4.1.2	M	
3	CC-CONNECT	CONNECT	5.2.4.1.3	M	
4	CC-CONNECT-ACK	----		I	(see note)
5	CC-INFO	INFORMATION	5.2.4.1.4 5.2.4.1.5	M	
6	CC-RELEASE	RELEASE	5.2.4.1.6	M	
7	CC-RELEASE-COM	RELEASE COMPLETE	5.2.4.1.7	M	
8	CC-SERVICE_CHANGE	----		X	
9	CC-SERVICE_ACCEPT	----		X	
10	CC-SERVICE_REJECT	----		X	
11	CC-SETUP	SETUP	5.2.4.1.8	M	
12	FACILITY	----		X	
13	IWU-INFO	----		X	
14	HOLD	----		X	
15	HOLD-ACK	----		X	
16	HOLD-REJECT	----		X	
17	RETRIEVE	----		X	
18	RETRIEVE-ACK	----		X	
19	RETRIEVE-REJECT	----		X	

NOTE: CC-CONNECT-ACK is sent by PT to confirmation connection of the call following a CC-CONNECT message in an external handover procedure.

5.2.4.1.1 CC-ALERTING - ALERTING

Table 7

	Message in DECT air interface	Message in B-ISDN network			
Item No	CC-ALERTING	ALERTING	Ref.	Map status	NOTE
1	protocol discriminator	protocol discriminator	5.2.6.17	M	
2	transaction identifier	call reference	5.2.6.22	M	
3	message type	message type	5.2.6.11	M	
4	----	message length		G	
5	----	connection identifier		G	
6	call attributes	----		X	
7	connection identity	----		X	
8	facility	----		X	
9	terminal capability	----		X	
10	transit delay	----		X	
11	window size	----		X	
12	IWU to IWU	narrowband bearer capability, narrowband high layer compatibility, notification indicator, progress indicator	5.2.5.1.11 5.2.5.1.11 5.2.5.1.11 5.2.5.1.11	C1 C1 C1 C1	
13	IWU packet	----		I	
C1:	IF Narrowband bearer capability information element is in <<IWU to IWU>> THEN M else X.				

5.2.4.1.2 CC-CALL-PROC - CALL PROCEEDING

Table 8

	Message in DECT air interface	Message in B-ISDN network			
Item No	CC-CALL-PROC	CALL PROCEEDING	Ref.	Map status	NOTE
1	protocol discriminator	protocol discriminator	5.2.6.17	M	
2	transaction identifier	call reference	5.2.6.22	M	
3	message type	message type	5.2.6.11	M	
4	----	message length		G	
5	----	connection identifier		G	
6	call attributes	----		X	
7	connection identity	----		X	
8	facility	----		X	
9	terminal capability	----		X	
10	transit delay	----		X	
11	window size	----		X	
12	IWU to IWU	narrowband bearer capability, narrowband high layer compatibility, notification indicator, progress indicator	5.2.5.1.11 5.2.5.1.11 5.2.5.1.11 5.2.5.1.11	C1 C1 C1 C1	
13	IWU packet	----		I	
C1:	IF Narrowband bearer capability information element is in <<IWU to IWU>> THEN M else X.				

5.2.4.1.3 CC-CONNECT - CONNECT

Table 9

	Message in DECT air interface	Message in B-ISDN network			
Item No	CC-CONNECT	CONNECT	Ref.	Map status	NOTE
1	protocol discriminator	protocol discriminator	5.2.6.17	M	
2	transaction identifier	call reference	5.2.6.22	M	
3	message type	message type	5.2.6.11	M	
4	----	message length		G	
5	----	connection identifier		G	
6	call attributes	----		X	
7	connection identity	----		X	
8	facility	----		X	
9	terminal capability	----		X	
10	transit delay	----		I	
11	window size	----		X	
12	IWU to IWU	narrowband bearer capability, narrowband high layer compatibility, narrowband low layer compatibility	5.2.5.1.11 5.2.5.1.11 5.2.5.1.11	C1 C1 C1	
13	IWU packet	----		I	
C1:	IF Narrowband bearer capability information element is in <<IWU to IWU>> THEN M else X.				

5.2.4.1.4 CC_INFO (F-02) - INFORMATION (U2)

Table 10

	Message in DECT air interface	Message in B-ISDN network			
Item No	CC-INFO (F-02)	INFORMATION (U2)	Ref.	Map status	NOTE
1	protocol discriminator	protocol discriminator	5.2.6.17	M	
2	transaction identifier	call reference	5.2.6.22	M	
3	message type	message type	5.2.6.11	M	
4	----	message length		G	
5	location area	----		X	
6	NWK assigned identity	----		X	
7	repeat indicator	----		I	
8	facility	----		X	
9	keypad	called party number	5.2.5.1.12	C1	
10	feature activate	----		X	
11	network parameter	----		X	
12	called party number	called party number	5.2.5.1.4	M	
13	called party sub-address	----		X	
14	sending complete	broadband sending complete	5.2.5.1.14	M	
15	repeat indicator	----		I	
16	IWU to IWU	----		I	
17	IWU packet	----		I	
C1:	IF called party number info THEN M ELSE X.				

5.2.4.1.5 CC_INFO - INFORMATION

Table 11

	Message in DECT air interface	Message in B-ISDN network			
Item No	CC-INFO	INFORMATION	Ref.	Map status	NOTE
1	protocol discriminator	protocol discriminator	5.2.6.17	M	
2	transaction identifier	call reference	5.2.6.22	M	
3	message type	message type	5.2.6.11	M	
4	----	message length		G	
5	location area	----		X	
6	NWK assigned identity	----		X	
7	repeat indicator	----		I	
8	facility	----		X	
9	keypad	----		X	
10	feature activate	----		X	
11	network parameter	----		X	
12	called party number	----		X	
13	called party sub-address	----		X	
14	sending complete	----		X	
15	repeat indicator	----		I	
16	IWU to IWU	For further study		I	
17	IWU packet	----		I	

5.2.4.1.6 CC-RELEASE - RELEASE

Table 12

	Message in DECT air interface	Message in B-ISDN network			
Item No	CC-RELEASE	RELEASE	Ref.	Map status	NOTE
1	protocol discriminator	protocol discriminator	5.2.6.17	M	
2	transaction identifier	call reference	5.2.6.22	M	
3	message type	message type	5.2.6.11	M	
4	----	message length		G	
5	release reason	cause	5.2.6.20	M	
6	facility	----		X	
7	IWU to IWU	----		I	
8	IWU packet	----		I	
9	progress indicator	progress indicator	5.2.5.1.13	M	

5.2.4.1.7 CC-RELEASE-COM - RELEASE COMPLETE

Table 13

	Message in DECT air interface	Message in B-ISDN network			
Item No	CC-RELEASE-COM	RELEASE COMPLETE	Ref.	Map status	NOTE
1	protocol discriminator	protocol discriminator	5.2.6.17	M	
2	transaction identifier	call reference	5.2.6.22	M	
3	message type	message type	5.2.6.11	M	
4	----	message length		G	
5	release reason	cause	5.2.6.20	M	
6	IWU attributes	----		I	
7	facility	----		X	
8	IWU to IWU	----		I	
9	IWU packet	----		I	

5.2.4.1.8 CC-SETUP - SETUP

Table 14

	Message in DECT air interface	Message in B-ISDN network			
Item No	CC-SETUP	SETUP	Ref.	Map status	NOTE
1	protocol discriminator	protocol discriminator	5.2.6.17	M	
2	transaction identifier	call reference	5.2.6.22	M	
3	message type	message type	5.2.6.11	M	
4	----	message length		G	
5	----	connection identifier		G	
6	portable identity	call reference	5.2.6.15	M	
7	fixed identity	----		I	
8	basic service	ATM traffic descriptor, AAL parameters, broadband bearer capability	5.2.5.1.2 5.2.5.1.1 5.2.5.1.3	C1 C1 C1	(see note)
9	IWU attributes	ATM traffic descriptor, AAL parameters, broadband bearer capability, broadband low layer information	5.2.5.1.8 5.2.5.1.7 5.2.5.1.9 5.2.5.1.10	M M C2	
10	repeat indicator	----		I	
11	call attributes	----		X	
12	repeat indicator	----		I	
13	connection attributes	----		X	
14	cipher info	----		X	
15	connection identity	----		X	
16	repeat indicator	----		I	
17	facility	----		X	
18	keypad	----		X	
19	feature activate	----		X	
20	network parameter	----		X	
21	terminal capability	----		X	
22	end-to-end compatibility	----		X	
23	rate parameters	----		X	
24	transit delay	----		I	
25	window size	----		X	
26	calling party number	calling party number	5.2.5.1.6	C3	
27	called party number	called party number	5.2.5.1.4	M	
28	called party sub-address	called party sub-address	5.2.5.1.5	M	
29	sending complete	broadband sending complete	5.2.5.1.14	M	
30	repeat indicator	----		I	
31	IWU to IWU	narrowband bearer capability, narrowband high layer compatibility, narrowband low layer compatibility	5.2.5.1.11 5.2.5.1.11 5.2.5.1.11	C4 C4 C4	
32	IWU packet	----		I	
C1: IF "basic speech default set-up attributes" in BASIC SERVICE THEN M else X. C2: IF Narrowband bearer capability information element is in <<IWU to IWU>> THEN X else M. C3: IF CLIR with option "per call" and "default override" subscribed then M else O. C4: IF Narrowband bearer capability information element is in <<IWU to IWU>> THEN M else X.					
NOTE: The "basic speech default set-up attributes", defined in EN 300 175-5 [3] - annex E as 32kbit/s ADPCM coded speech, is assumed coded/decoded from/to the B-ISDN 64 kbit/s voice-band.					

5.2.4.2 Message Mapping - B-ISDN to DECT

Table 15

Item No	B-ISDN message	DECT message	Ref.	Map Status	NOTE
1	ALERTING	CC-ALERTING	5.2.4.2.1	M	
2	CALL PROCEEDING	CC-CALL-PROC	5.2.4.2.2	M	
3	CONNECT	CC-CONNECT	5.2.4.2.3	M	
4	CONNECT ACKNOWLEDGE	CC-CONNECT-ACK	5.2.4.2.4	M	
5	INFORMATION	CC-INFO	5.2.4.2.5	M	
6	NOTIFY	CC-NOTIFY		I	
7	RELEASE	CC-RELEASE	5.2.4.2.6	M	
8	RELEASE COMPLETE	CC-RELEASE-COM	5.2.4.2.7	M	
9	SETUP	CC-SETUP	5.2.4.2.8	M	
10	SETUP ACKNOWLEDGE	CC-SETUP-ACK	5.2.4.2.9	M	
11	STATUS	----		X	(see note)
12	STATUS ENQUIRY	----		X	(see note)

NOTE: The STATUS and STATUS ENQUIRY messages shall not be mapped between the DECT and B-ISDN system, but the interworking function must respond to a STATUS ENQUIRY message as specified by ITU-T Recommendation Q.2931 [41].

5.2.4.2.1 ALERTING - CC-ALERTING

Table 16

Item No	Message in B-ISDN network	Message in DECT air interface	Ref.	Map status	NOTE
	ALERTING	CC-ALERTING			
1	protocol discriminator	protocol discriminator	5.2.6.17	M	
2	call reference	transaction identifier	5.2.6.22	M	
3	message type	message type	5.2.6.11	M	
4	message length	----		N/A	
5	connection identifier	----		N/A	1
6	narrowband bearer capability	----		I	2
7	narrowband high layer compatibility	----		I	2
8	notification indicator	IWU to IWU	5.2.5.1.11	O	
9	progress indicator	progress indicator	5.2.5.1.13	M	2

NOTE 1: This information element may only be included in ALERTING messages related to B-ISDN services.

NOTE 2: This information element may only be included in ALERTING messages related to the support of 64 kbit/s based ISDN circuit mode services.

5.2.4.2.2 CALL PROCEEDING - CC-CALL-PROC

Table 17

	Message in B-ISDN network	Message in DECT air interface			
Item No	CALL PROCEEDING	CC-CALL-PROC	Ref.	Map status	NOTE
1	protocol discriminator	protocol discriminator	5.2.6.17	M	
2	call reference	transaction identifier	5.2.6.22	M	
3	message type	message type	5.2.6.11	M	
4	message length	----		N/A	
5	connection identifier	----		N/A	
6	narrowband bearer capability	----		I	(see note)
7	narrowband high layer compatibility	----		I	(see note)
8	notification indicator	IWU to IWU	5.2.5.1.11	O	
9	progress indicator	progress indicator	5.2.5.1.13	M	(see note)
NOTE: This information element may only be included in CALL PROCEEDING messages related to the support of 64 kbit/s based ISDN circuit mode services.					

5.2.4.2.3 CONNECT - CC-CONNECT

Table 18

	Message in B-ISDN network	Message in DECT air interface			
Item No	CONNECT	CC-CONNECT	Ref.	Map status	NOTE
1	protocol discriminator	protocol discriminator	5.2.6.17	M	
2	call reference	transaction identifier	5.2.6.22	M	
3	message type	message type	5.2.6.11	M	
4	message length	----		N/A	
5	AAL parameters	----		X	
6	broadband low layer information	----		X	1
7	connection identifier	----		N/A	1
8	end-to-end transit delay	----		I	
9	narrowband bearer capability	----		I	2
10	narrowband high layer compatibility	----		I	2
11	narrowband low layer compatibility	IWU to IWU	5.2.5.1.11	O	2
12	notification indicator	IWU to IWU	5.2.5.1.11	O	
13	OAM traffic descriptor	----		N/A	
14	progress indicator	progress indicator	5.2.5.1.13	M	2
NOTE 1: This information element may only be included in CONNECT messages related to B-ISDN services.					
NOTE 2: This information element may only be included in CONNECT messages related to the support of 64 kbit/s based ISDN circuit mode services.					

5.2.4.2.4 CONNECT ACKNOWLEDGE - CC-CONNECT-ACK

Table 19

	Message in B-ISDN network	Message in DECT air interface			
Item No	CONNECT ACKNOWLEDGE	CC-CONNECT-ACK	Ref.	Map status	NOTE
1	protocol discriminator	protocol discriminator	5.2.6.17	M	
2	call reference	transaction identifier	5.2.6.22	M	
3	message type	message type	5.2.6.11	M	
4	message length	----		N/A	
5	notification indicator	IWU to IWU	5.2.5.1.11	O	

5.2.4.2.5 INFORMATION - CC-INFO

Table 20

	Message in B-ISDN network	Message in DECT air interface			
Item No	INFORMATION	CC-INFO	Ref.	Map status	NOTE
1	protocol discriminator	protocol discriminator	5.2.6.17	M	
2	call reference	transaction identifier	5.2.6.22	M	
3	message type	message type	5.2.6.11	M	
4	message length	----		N/A	
5	broadband sending complete	----		I	
6	called party number	----		I	

5.2.4.2.6 RELEASE - CC-RELEASE

Table 21

	Message in B-ISDN network	Message in DECT air interface			
Item No	RELEASE	CC-RELEASE	Ref.	Map status	NOTE
1	protocol discriminator	protocol discriminator	5.2.6.17	M	
2	call reference	transaction identifier	5.2.6.22	M	
3	message type	message type	5.2.6.11	M	
4	message length	----		N/A	
5	cause	release reason	5.2.6.20	M	
6	notification indicator	IWU to IWU	5.2.5.1.11	O	
7	progress indicator	progress indicator	5.2.5.1.13	M	(see note)
NOTE:	This information element may only be included in CONNECT messages related to the support of 64 kbit/s based ISDN circuit mode services.				

5.2.4.2.7 RELEASE COMPLETE - CC-RELEASE-COM

Table 22

	Message in B-ISDN network	Message in DECT air interface			
Item No	RELEASE COMPLETE	CC-RELEASE-COM	Ref.	Map status	NOTE
1	protocol discriminator	protocol discriminator	5.2.6.17	M	
2	call reference	transaction identifier	5.2.6.22	M	
3	message type	message type	5.2.6.11	M	
4	message length	----		N/A	
5	cause	release reason	5.2.6.20	M	

5.2.4.2.8 SETUP - CC-SETUP

Table 23

Item No	Message in B-ISDN network SETUP	Message in DECT air interface CC-SETUP	Ref.	Map status	NOTE
1	protocol discriminator	protocol discriminator	5.2.6.17	M	
2	call reference	transaction identifier portable identity	5.2.6.22 5.2.6.15	M	
3	message type	message type	5.2.6.11	M	
4	message length	----		N/A	
5	AAL parameters	basic service, IWU attributes	5.2.5.1.1 5.2.5.1.7	C1a C1b	1
6	ATM traffic descriptor	basic service, IWU attributes	5.2.5.1.2 5.2.5.1.8	C1a C1b	1
7	broadband bearer capability	basic service, IWU attributes	5.2.5.1.3.2 5.2.5.1.9	C1a C1b	1
8	broadband high layer information	----		N/A	2
9	broadband repeat indicator	----		I	2
10	broadband low layer information	IWU attributes	5.2.5.1.10	C1a	2
11	called party number	called party number	5.2.5.1.4	M	
12	called party sub-address	called party sub-address	5.2.5.1.5	C3	
13	calling party number	calling party number	5.2.5.1.6	C2	
14	calling party sub-address	IWU to IWU	5.2.5.1.11	C3	
15	connection identifier	----		N/A	
16	end-to-end transit delay	----		I	
17	broadband repeat indicator	----		I	3
18	narrowband bearer capability	IWU to IWU	5.2.5.1.11	M	3
19	narrowband high layer compatibility	IWU to IWU	5.2.5.1.11	M	3
20	broadband repeat indicator	----		I	3
21	narrowband low layer compatibility	IWU to IWU	5.2.5.1.11	M	3
22	notification indicator	----		I	
23	OAM traffic descriptor	----		N/A	
24	progress indicator	progress indicator	5.2.5.1.13	M	
25	QoS parameter	----		N/A	
26	broadband sending complete	sending complete	5.2.5.1.14	O	
C1a: IF B-ISDN 64 kbit/s voice-band THEN M else X (see subclause 5.2.5.1.3.2). C1b: IF C1b THEN X else M. C2: IF CLIP THEN M ELSE O. C3: IF SUB THEN M ELSE O.					
NOTE 1: The "basic speech default set-up attributes", defined in EN 300 175-5 [3] - annex E as 32 kbit/s ADPCM coded speech, is assumed coded/decoded from/to the B-ISDN 64 kbit/s voice-band.					
NOTE 2: This information element may only be included in SETUP messages related to B-ISDN services.					
NOTE 3: This information element may only be included in SETUP messages related to the support of 64 kbit/s based ISDN circuit mode services.					

5.2.4.2.9 SETUP ACKNOWLEDGE - CC-SETUP-ACK

Table 24

	Message in B-ISDN network	Message in DECT air interface			
Item No	SETUP ACKNOWLEDGE	CC-SETUP-ACK	Ref.	Map status	NOTE
1	protocol discriminator	protocol discriminator	5.2.6.17	M	
2	call reference	transaction identifier	5.2.6.22	M	
3	message type	message type	5.2.6.11	M	
4	message length	----		N/A	
5	connection identifier	----		N/A	
6	notification indicator	IWU to IWU	5.2.5.1.11	O	
7	progress indicator	progress indicator	5.2.5.1.13	M	

5.2.5 Information Element mapping

5.2.5.1 B-ISDN to DECT and DECT to B-ISDN

5.2.5.1.1 Basic Service - AAL parameters

If Basic Service is "basic speech default set-up attributes" the AAL parameters must be set as in ITU-T Recommendation Q.2931 [41] - E.4.2.4.2 (AAL for voice).

5.2.5.1.2 Basic Service - ATM Traffic descriptor

If Basic Service is "basic speech default set-up attributes" the ATM traffic descriptor must be set as in ITU-T Recommendation Q.2931 [41] - E.4.2.2.2 (equal to 64kbit/s).

5.2.5.1.3 Basic Service - Broadband Bearer Capability

5.2.5.1.3.1 DECT to B-ISDN

If Basic Service is "basic speech default set-up attributes" the Broadband Bearer Capability must be set as in ITU-T Recommendation Q.2931 [41] - E.4.2.1 (BCOB-A).

5.2.5.1.3.2 B-ISDN to DECT

If Broadband Bearer Capability is set as in ITU-T Recommendation Q.2931 [41] - E.4.2.1 (BCOB-A) and the ATM traffic descriptor is set as in ITU-T Recommendation Q.2931 [41] - E.4.2.2.2 (equal to 64kbit/s) and the AAL parameters is set as in ITU-T Recommendation Q.2931 [41] - E.4.2.4.3 (equal to AAL for voice), then Basic Service must be set to "basic speech default set-up attributes".

5.2.5.1.4 Called Party Number - Called Party Number

Table 25

	Information element in DECT air interface	Information element in B-ISDN network			
Item No	Called party number	Called party number	Ref.	Map status	NOTE
1	ID for called party number	information element identifier	5.2.6.3	M	
2	length of contents	length of called party number contents	5.2.6.9	M	
3	number type	type of number	5.2.6.13	M	
4	numbering plan identification	addressing/numbering plan identification	5.2.6.12	M	
5	called party address (DECT char)	address/number digits (IA5 char)		M	(see note)
NOTE: Only the IA5 characters in DECT char shall be mapped into IA5 char.					

5.2.5.1.5 Called Party Sub-address - Called Party Sub-address

Table 26

	Information element in DECT air interface	Information element in B-ISDN network			
Item No	Called party sub-address	Called party sub-address	Ref.	Map status	NOTE
1	ID for called party sub-address	information element identifier	5.2.6.3	M	
2	length of contents	length of called party sub-address contents	5.2.6.9	M	
3	sub-address type	type of sub-address	5.2.6.21	M	
4	odd/even	odd/even indicator	5.2.6.14	M	
5	sub-address information	sub-address information		M	

5.2.5.1.6 Calling Party Number - Calling Party Number

Table 27

	Information element in DECT air interface	Information element in B-ISDN network			
Item No	Calling party number	Calling party number	Ref.	Map status	NOTE
1	ID for calling party number	information element identifier	5.2.6.3	M	
2	length of contents	length of calling party number contents	5.2.6.9	M	
3	number type	type of number	5.2.6.13	M	
4	numbering plan identification	addressing/numbering plan identification	5.2.6.12	M	
5	presentation indicator	----		X	
6	screening indicator	----		X	
7	calling party address (DECT char)	address/number digits (IA5 char)		M	(see note)
NOTE: Only the IA5 characters in DECT char shall be mapped into IA5 char.					

5.2.5.1.7 IWU Attributes - AAL parameters

Table 28

Item No	Information element in DECT air interface IWU attributes	Information element in B-ISDN network AAL parameters	Ref.	Map status	NOTE
1	ID for IWU attributes	information element identifier	5.2.6.3	M	
2	length of contents	length of AAL parameters contents	5.2.6.9	M	
3	coding standard	coding standard	5.2.6.1	M	
4	info transfer capability	<<Broadband bearer capability>> AAL subtype	5.2.6.4	M	
5	negotiation indicator	----		X	
6	external connection type	----		X	
7	transfer mode	<<Broadband bearer capability>> AAL type	5.2.6.23	M	
8	info transfer rate (octet 5)	<<ATM Traffic descriptor>> CBR rate	5.2.6.5	M	(see note)
9	unit rate (octet 5a)	CBR rate	5.2.6.25	M	(see note)
10	rate multiplier (octet 5a)	Multiplier	5.2.6.19	M	(see note)
11	structure	----		X	
12	configuration	<<Broadband bearer capability>>			
13	establishment	----		X	
14	symmetry	----		X	(see note)
15	info transfer rate (octet 5c)	----		X	(see note)
16	unit rate (octet 5d)	----		X	(see note)
17	rate multiplier (octet 5d)	----		X	(see note)
18	protocol ID coding	<<Broadband low layer information>>		M	
19	user protocol ID	----		X	
20	L2 protocol ID	<<Broadband low layer information>>		M	
21	L3 protocol ID	<<Broadband low layer information>>		M	

NOTE: Only symmetric CBR calls can be mapped.

5.2.5.1.8 IWU Attributes - ATM Traffic descriptor

Table 29

	Information element in DECT air interface	Information element in B-ISDN network			
Item No	IWU attributes	ATM traffic descriptor	Ref.	Map status	NOTE
1	ID for IWU attributes	information element identifier	5.2.6.3	M	
2	length of contents	length of ATM traffic descriptor contents	5.2.6.9	M	
3	coding standard	coding standard	5.2.6.1	M	
4	info transfer capability	<<Broadband bearer capability>> <<AAL parameters>>		M	
5	negotiation indicator	----		X	
6	external connection type	----		X	
7	transfer mode	<<Broadband bearer capability>>		M	
8	info transfer rate (octet 5)	forward peak cell rate backward peak cell rate <<AAL parameters>>	5.2.6.6 5.2.6.6	M	
9	unit rate (octet 5a)	<<AAL parameters>>			
10	rate multiplier (octet 5a)	<<AAL parameters>>			
11	structure	----		X	
12	configuration	<<Broadband bearer capability>>			
13	establishment	----		X	
14	symmetry	----		X	(see note)
15	info transfer rate (octet 5c)	----		X	(see note)
16	unit rate (octet 5d)	----		X	(see note)
17	rate multiplier (octet 5d)	----		X	(see note)
18	protocol ID coding	<<Broadband bearer capability>>			
19	user protocol ID	----		X	
20	L2 protocol ID	<<Broadband low layer information>>		M	
21	L3 protocol ID	<<Broadband low layer information>>		M	
NOTE: Only symmetric CBR calls can be mapped.					

5.2.5.1.9 IWU Attributes - Broadband Bearer Capability

Table 30

Item No	Information element in DECT air interface IWU attributes	Information element in B-ISDN network Broadband bearer capability	Ref.	Map status	NOTE
1	ID for IWU attributes	information element identifier	5.2.6.3	M	
2	length of contents	length of broadband bearer capability contents	5.2.6.9	M	
3	coding standard	coding standard	5.2.6.1	M	
4	info transfer capability	<<AAL parameters>>		M	
5	negotiation indicator	----		X	
6	external connection type	----		X	
7	transfer mode	bearer class	5.2.6.24	M	
8	info transfer rate (octet 5)	<<ATM Traffic descriptor>> <<AAL parameters>>			
9	unit rate (octet 5a)	<<AAL parameters>>			
10	rate multiplier (octet 5a)	<<AAL parameters>>			
11	structure	----		X	
12	configuration	user plane connection configuration	5.2.6.2	M	
13	establishment	----		X	
14	symmetry	----		X	1
15	info transfer rate (octet 5c)	----		X	1
16	unit rate (octet 5d)	----		X	1
17	rate multiplier (octet 5d)	----		X	1
18	protocol ID coding	<<Broadband low layer information>>			
19	user protocol ID	----			
20	L2 protocol ID	<<Broadband low layer information>>			
21	L3 protocol ID	<<Broadband low layer information>>			
22	----	susceptibility to clipping		X	2

NOTE 1: Only symmetric CBR calls can be mapped.
NOTE 2: This field should be set to '00'B, "not susceptible to clipping".

5.2.5.1.10 IWU Attributes - Broadband Low Layer Information

Table 31

	Information element in DECT air interface	Information element in B-ISDN network			
Item No	IWU attributes	Broadband low layer information	Ref.	Map status	NOTE
1	ID for IWU attributes	information element identifier	5.2.6.3	M	
2	length of contents	length of broadband low layer information contents	5.2.6.9	M	
3	coding standard	coding standard	5.2.6.1	M	
4	info transfer capability	<<Broadband bearer capability>> <<AAL parameters>>		M	
5	negotiation indicator	----		X	
6	external connection type	----		X	
7	transfer mode	<<Broadband bearer capability>>			
8	info transfer rate (octet 5)	<<ATM Traffic descriptor>> <<AAL parameters>>			
9	unit rate (octet 5a)	<<AAL parameters>>			
10	rate multiplier (octet 5a)	<<AAL parameters>>			
11	structure	----			
12	configuration	<<Broadband bearer capability>>			
13	establishment	----		X	
14	symmetry	----		X	(see note)
15	info transfer rate (octet 5c)	----		X	(see note)
16	unit rate (octet 5d)	----		X	(see note)
17	rate multiplier (octet 5d)	----		X	(see note)
18	protocol ID coding	protocol ID coding	5.2.6.18	M	
19	user protocol ID	----			
20	L2 protocol ID	user information layer 2 protocol	5.2.6.7	M	
21	L3 protocol ID	user information layer 3 protocol	5.2.6.8	M	
NOTE: Only symmetric CBR calls can be mapped.					

5.2.5.1.11 IWU to IWU - B-ISDN Information Element

Table 32

	Information element in DECT air interface	Information element in B-ISDN network			
Item No	IWU to IWU	B-ISDN information element	Ref.	Map status	NOTE
1	ID for IWU to IWU	information element identifier		X	
2	length of contents	length of narrowband bearer capability contents		X	
3	send/reject	----		X	1
4	protocol discriminator	----		X	2
5	IWU to IWU info	B-ISDN information element		M	3

NOTE 1: This field should be set to '1'B, "transmission of message".
NOTE 2: The protocol discriminator shall be '001001'B which means N-ISDN information element(s).
NOTE 3: The whole B-ISDN information element shall be mapped into <IWU to IWU info> without changes in the B-ISDN to DECT direction. The <IWU to IWU info> shall contain the whole B-ISDN information element. The B-ISDN information elements in <IWU to IWU info> shall only be information elements which are allowed to be sent in the B-ISDN message, the DECT message is mapped to.

5.2.5.1.12 Keypad - Called Party Number

Table 33

	Information element in DECT air interface	Information element in B-ISDN network			
Item No	Keypad	Called party number	Ref.	Map status	NOTE
1	ID for keypad	information element identifier	5.2.6.3	M	
2	length of contents	length of called party number contents	5.2.6.9	M	
3	----	type of number		X	1
4	----	addressing/numbering plan identification		X	2
5	keypad info	address/number digits		M	3

NOTE 1: This field should be set to '000'B, "unknown".
NOTE 2: This field should be set to '0000'B, "unknown".
NOTE 3: Only the IA5 characters in DECT char shall be mapped into IA5 char.

5.2.5.1.13 Progress Indicator - Progress Indicator

Table 34

	Information element in DECT air interface	Information element in B-ISDN network			
Item No	Progress indicator	Progress indicator	Ref.	Map status	NOTE
1	ID for progress indicator	information element identifier	5.2.6.3	M	
2	length of contents	length of progress indicator contents	5.2.6.9	M	
3	coding standard	coding standard	5.2.6.1	M	
4	location	location	5.2.6.10	M	
5	progress description	progress description	5.2.6.16	M	

5.2.5.1.14 Sending Complete - Broadband Sending Complete

Table 35

Item No	Information element in DECT air interface	Information element in B-ISDN network	Ref.	Map status	NOTE
	Sending complete	Broadband sending complete			
1	ID for sending complete	information element identifier	5.2.6.3	M	
2	----	length of broadband sending complete contents		X	1
3	----	broadband sending complete indication		X	2

NOTE 1: The length of broadband sending complete contents should be set to 1 octet.
NOTE 2: The broadband sending complete indication should be set to '0100001'B.

5.2.6 Information Element Coding mapping

5.2.6.1 Coding standard - Coding standard

Table 36

Item No	Information element in DECT air interface		Information element in B-ISDN network		Map status	NOTE
	Coding standard		Coding standard			
1	'00'B	DECT standard	'00'B	ITU-T standard	M	
2	----	----	'01'B	ISO/IEC standard	N/A	
3	----	----	'10'B	national standard	N/A	
4	----	----	'11'B	standard defined for the network	N/A	

5.2.6.2 Configuration - User plane connection configuration

Table 37

Item No	Information element in DECT air interface		Information element in B-ISDN network		Map status	NOTE
	Configuration		User plane connection configuration			
1	'00'B	point-to-point	'00'B	point-to-point	M	
2	----		'01'B	point-to-multipoint	N/A	

5.2.6.3 ID for Information Element - Information Element Identifier

The element identifier mapping is depending of which message it is sent in. The table which refers to this subclause shows which element identifiers shall be mapped with each other.

5.2.6.4 Info Transfer Capability - AAL Subtype

Table 38

Item No	Information element in DECT air interface		Information element in B-ISDN network		Map status	NOTE
	Info transfer capability		AAL subtype			
1	'00000'B	speech	'00000001'B	voice-band		TBS
2	'01000'B	unrest. dig. info	'00000010'B	circuit-transport		TBS
3	'01001'B	rest. dig. info	'00000010'B	circuit-transport		TBS
4	'10000'B	3,1 khz audio	'00000100'B	audio		TBS
5	'10100'B	7,0 khz audio	'00000100'B	audio		TBS
6	'11000'B	video	'00000101'B	video		TBS

5.2.6.5 Info Transfer Rate - CBR Rate

Table 39

Item No	Information element in DECT air interface		Information element in B-ISDN network		Map status	NOTE
	Info transfer rate		CBR rate			
1	'00000'B	packet mode calls	-----		I	TBS
2	'00010'B	16 kbit/s	-----		I	
3	'00011'B	32 kbit/s	-----		I	
4	'10000'B	64 kbit/s	'00000001'B	64 kbit/s	M	
5	-----		'00000100'B	1 544 kbit/s	I	
6	-----		'00000101'B	6 312 kbit/s	I	
7	-----		'00000110'B	32 064 kbit/s	I	
8	-----		'00000111'B	44 736 kbit/s	I	
9	-----		'00001000'B	97 728 kbit/s	I	
10	-----		'00010000'B	2 048 kbit/s	I	
11	-----		'00010001'B	8 448 kbit/s	I	
12	-----		'00010010'B	34 368 kbit/s	I	
13	-----		'00010011'B	139 264 kbit/s	I	
14	'10001'B	2 x 64 kbit/s	'01000000'B	n x 64 kbit/s	M	1
15	'10011'B	384 kbit/s	'01000000'B	n x 64 kbit/s	M	2
16	-----		'01000001'B	n x 8 kbit/s	I	
17	'11110'B	undefined	-----		I	
18	'11111'B	defined by rate multiplier	-----		I	3

NOTE 1: Multiplier n = 2.
NOTE 2: Multiplier n = 6.
NOTE 3: See subclauses 5.2.6.19 and 5.2.6.25.

5.2.6.6 Info Transfer Rate - Peak Cell Rates

Table 40

Item No	Information element in DECT air interface		Information element in B-ISDN network		Map status	NOTE
	Info transfer rate		peak cell rates			
1	'00000'B	packet mode calls	200 cells/sec		M	
2	'00010'B	16 kbit/s	200 cells/sec		M	
3	'00011'B	32 kbit/s	200 cells/sec		M	
4	'10000'B	64 kbit/s	200 cells/sec		M	
5	'10001'B	2 x 64 kbit/s	400 cells/sec		M	
6	'10011'B	384 kbit/s	1200 cells/sec		M	
7	'11110'B	undefined			M	
8	'11111'B	defined by rate multiplier			M	TBS

5.2.6.7 L2 Protocol ID - User Information Layer 2 Protocol

Table 41

Item No	Information element in DECT air interface		Information element in B-ISDN network		Map status	NOTE
	L2 protocol ID		User information layer 2 protocol			
1	'00000'B	user specific	'10000'B	user specified	M	TBS
2	'00001'B	basic mode ISO 1745 [18]	'00001'B	basic mode ISO 1745 [18]	M	
3	'00010'B	ITU-T Recommendation Q.921 [39]	'00010'B	ITU-T Recommendation Q.921 [39]	M	
4	'00110'B	ITU-T Recommendation X.25 [45] link layer	'00110'B	ITU-T Recommendation X.25 [45] link layer	M	
5	'00111'B	ITU-T Recommendation X.25 [45] multilink	'00111'B	ITU-T Recommendation X.25 [45] multilink	M	
6	'01000'B	extended LAPB; for half-duplex operation (ITU-T Recommendation T.71 [43])	'01000'B	extended LAPB; for half-duplex operation (Recommendation T.71 [43])	M	
7	-----		'01001'B	HDLC ARM (ISO/IEC 4335 [19])	I	
8	-----		'01010'B	HDLC NRM (ISO/IEC 4335 [19])	I	
9	-----		'01011'B	HDLC ABM (ISO/IEC 4335 [19])	I	
10	'01100'B	LAN logical link control (ISO/IEC 8802-2 [24])	'01100'B	LAN logical link control (ISO/IEC 8802-2 [24])	M	
11	-----		'01101'B	ITU-T Recommendation X.75 [46] single link procedure	I	
12	-----		'01110'B	ITU-T Recommendation Q.922 [40]	I	
13	'10001'B	ISO Pub. 8802/x	'10001'B	ISO/IEC 7776 [20] DTE-DTE operation	X	
14	'10010'B	GSM 04.06 [16]	-----		I	
15	'10110'B	ITU-T Recommendation V.42 [44]	-----		I	

5.2.6.8 L3 protocol ID - User Information Layer 3 Protocol

Table 42

Item No	Information element in DECT air interface		Information element in B-ISDN network		Map status	NOTE
	L2 protocol ID		User information layer 2 protocol			
1	'00000'B	user specific	'10000'B	user specified	M	TBS
2	'00010'B	EN 300 102-1 [2]	-----		I	
3	'00110'B	ITU-T Recommendation X.25 [45] packet layer	'00110'B	ITU-T Recommendation X.25 [45] packet layer	M	
4	'00111'B	ISO Pub. 8208 [21] DTE-DTE operation	'00111'B	ISO/IEC 8208 [21] DTE-DTE operation	M	
5	'01000'B	ISO Pub. 8348 [22]	'01000'B	ITU-T Recommendation X.223 [48] ISO/IEC 8878 [25]	X	TBS
6	'01001'B	ISO Pub. 8473 [23]	'01001'B	ITU-T Recommendation X.233 [49] ISO/IEC 8473 [23]	M	
7	'01010'B	ITU-T Recommendation T.70 [42]	'01010'B	ITU-T Recommendation T.70 [42]	M	
8	-----		'01011'B	ISO/IEC TR 9577 [26]	I	
9	'10010'B	GSM 04.08 [17]	-----		I	

5.2.6.9 Length of contents - Length of contents

The length is calculated by the interworking function.

5.2.6.10 Location - Location

Table 43

	Information element in DECT air interface		Information element in B-ISDN network			
Item No	Location		Location		Map status	NOTE
1	'0000'B	user	'0000'B	user	M	
2	'0001'B	private network serving the local user	'0001'B	private network serving the local user	M	
3	'0010'B	public network serving the local user	'0010'B	public network serving the local user	M	
4	----		'0011'B	transit network	I	
5	'0100'B	public network serving the remote user	'0100'B	public network serving the remote user	M	
6	'0101'B	private network serving the remote user	'0101'B	private network serving the remote user	M	
7	'0111'B	international network	----		I	
8	'1010'B	network beyond the interworking point	'1010'B	network beyond the interworking point	M	
9	'1111'B	not applicable	----		I	

5.2.6.11 Message type - Message type

Table 44

Item No	Information element in DECT air interface		Information element in B-ISDN network		Map status	NOTE
	Message type		Message type			
1	'00000001'B	CC-ALERTING	'00000001'B	ALERTING	M	
2	'00000010'B	CC-CALL-PROC	'00000010'B	CALL PROCEEDING	M	
3	----		'00000011'B	PROGRESS	I	
4	'00000101'B	CC-SETUP	'00000101'B	SETUP	M	
5	'00000111'B	CC-CONNECT	'00000111'B	CONNECT	M	
6	'00001101'B	CC-SETUP-ACK	'00001101'B	SETUP ACKNOWLEDGE	M	
7	'00001111'B	CC-CONNECT-ACK	'00001111'B	CONNECT ACKNOWLEDGE	M	
8	'00100000'B	CC-SERVICE-CHANGE	----		I	
9	'00100001'B	CC-SERVICE-ACCEPT	----		I	
10	'00100011'B	CC-SERVICE-REJECT	----		I	
11	----		'01000110'B	RESTART	I	
12	'01001101'B	CC-RELEASE	'01001101'B	RELEASE	M	
13	----		'01001110'B	RESTART ACKNOWLEDGE	I	
14	'01011010'B	CC-RELEASE-COM	'01011010'B	RELEASE COMPLETE	M	
15	'01100000'B	IWU-INFO	----		I	
16	'01101110'B	CC-NOTIFY	'01101110'B	NOTIFY	X	
17	----		'01110101'B	STATUS ENQUIRY	I	
18	'01111011'B	CC-INFO	'01111011'B	INFORMATION	M	
19	----		'01111101'B	STATUS	I	

5.2.6.12 Numbering Plan Identification - Numbering Plan Identification

Table 45

Item No	Information element in DECT air interface		Information element in B-ISDN network		Map status	NOTE
	Numbering plan identification		Numbering plan identification			
1	'0000'B	unknown	'0000'B	unknown	M	
2	'0001'B	ISDN numbering plan ([E.164 [50]])	'0001'B	ISDN numbering plan (E.164 [50])	M	
3	'0011'B	data plan (X.121 [51])	----		I	
4	----		'0010'B	NSAP addressing (ISO/IEC 8348 [22])	I	
5	'1000'B	national standard plan	----		I	
6	'1001'B	private plan	'1001'B	private numbering plan	M	
7	'1111'B	reserved	'1111'B	reserved	M	

5.2.6.13 Number Type - Type Of Number

Table 46

Item No	Information element in DECT air interface		Information element in B-ISDN network		Map status	NOTE
	Number type		Type of number			
1	'000'B	unknown	'0000'B	unknown	M	
2	'001'B	international number	'0001'B	ISDN numbering plan (E.164 [50])	M	
3	'010'B	national number	----		I	
4	'011'B	network specific number	----		I	
5	'001'B	subscriber number	'1001'B	private numbering plan	M	
6	'001'B	abbreviated number	'1001'B	private numbering plan	M	
7	'111'B	reserved	'1111'B	reserved	M	

5.2.6.14 Odd/even - Odd/Even Indicator

Table 47

Item No	Information element in DECT air interface		Information element in B-ISDN network		Map status	NOTE
	Odd/even		Odd/even indicator			
1	'0'B	even number	'0'B	even number	M	
2	'1'B	odd number	'1'B	odd number	M	

5.2.6.15 Portable Identity - Call Reference

The DECT Portable Identity information element is inserted unchanged into the B-ISDN Call Reference information element. The DECT Portable Identity information element extends octet 2, bit position 4 to octet 4 bit position 5 of the B-ISDN Call Reference information element.

Only Portable Identity type "Temporary Portable User Identity" is allowed.

Table 48

Item No	Information element in DECT air interface	Information element in B-ISDN network	Map status	NOTE
	Portable Identity	Call reference		
1	Length of identity value	----	M	1
2	Type	----	M	2
NOTE 1: Length of identity value must be 20 bits.				
NOTE 2: The portable identity type must be "Temporary Portable User Identity (TPUI)" with coding '010000'B.				

5.2.6.16 Progress Description - Progress Description

Table 49

Item No	Information element in DECT air interface		Information element in B-ISDN network		Map status	NOTE
	Progress description		Progress description			
1	'0000001'B	call is not end-to-end ISDN; further call progress info may be available in-band	'0000001'B	call is not end-to-end ISDN; further call progress info may be available in-band	M	
2	'0000010'B	destination address is non-ISDN	'0000010'B	destination address is non-ISDN	M	
3	'0000011'B	origination address is non-ISDN	'0000011'B	origination address is non-ISDN	M	
4	'0000100'B	call has returned to the ISDN	'0000100'B	call has returned to the ISDN	M	
5	----		'0000101'B	interworking has occurred and has resulted in a telecommunication service change	I	
6	'0001000'B	in-band information or appropriate pattern now available	'0001000'B	in-band information or appropriate pattern now available	M	
7	'0001001'B	in-band information not available	----		I	

5.2.6.17 Protocol Discriminator - Protocol Discriminator

Table 50

Item No	Information element in DECT air interface		Information element in B-ISDN network		Map status	NOTE
	Protocol discriminator		Protocol discriminator			
1	'0000'B	LCE	----		I	
2	'0011'B	CC	'00001001'B	Q2931 [41] CC	M	
3	'0100'B	CISS	----		I	
4	'0101'B	MM	----		I	
5	'0110'B	CLMS	----		I	
6	'0111'B	COMS	----		I	
7	'1 - - -'B	unknown	----		I	

5.2.6.18 Protocol Identifier Coding - Protocol Identifier Coding

Table 51

Item No	Information element in DECT air interface		Information element in B-ISDN network		Map status	NOTE
	Protocol identifier coding		Protocol identifier coding			
1	'00'B	user protocol ID	----		I	
2	----		'01'B	layer 1 ID	I	
3	'10'B	L2 protocol ID	'10'B	layer 2 ID	M	
4	'11'B	L3 protocol ID	'11'B	layer 3 ID	M	

5.2.6.19 Rate multiplier - Multiplier

Table 52

Item No	Information element in DECT air interface	Information element in B-ISDN network	Map status	NOTE
	Rate multiplier	Multiplier		
1	"1"	----	I	
2	number between "2" and "15"	number between "2" and "15"	M	(see note)
3	----	number between "16" and "65535"	I	
NOTE: "rate multiplier" relates to "unit rate" and "multiplier" relates to "cbr rate" (see subclause 5.2.6.25).				

5.2.6.20 Release Reason - Cause

5.2.6.20.1 DECT to B-ISDN

Table 53

Item No	Information element in DECT air interface		Information element in B-ISDN network		Map status	NOTE
	Release Reason		Cause			
1	'00'H	normal	'10'H	normal call clearing	M	
2	'01'H	unexpected message	'7F'H	interworking, unspecified	M	
3	'02'H	unknown transaction Identifier	'7F'H	interworking, unspecified	M	
4	'03'H	mandatory information element missing	'16'H	Manadatory Information Element missing	M	
5	'04'H	invalid information element contents	'7F'H	interworking, unspecified	M	
6	'05'H	incompatible service	'7F'H	interworking, unspecified	M	
7	'06'H	service not implemented	'4F'H	service or option not imple-mented, unspecified	M	
8	'07'H	negotiation not supported	'7F'H	interworking, unspecified	M	
9	'08'H	invalid identity	'7F'H	interworking, unspecified	M	
10	'09'H	authentication failed	'7F'H	interworking, unspecified	M	
11	'0A'H	unknown identity	'7F'H	interworking, unspecified	M	
12	'0B'H - '0C'H	reserved	-----	-	X	
13	'0D'H	timer expiry	'7F'H	interworking, unspecified	M	
14	'0E'H	partial release	'7F'H	interworking, unspecified		
15	'0F'H	unknown	'1F'H	normal, unspecified	M	
16	'10'H	user detached	'12'H	no user responding	M	
17	'11'H	user not in range	'03'H	no route to destination	M	
18	'12'H	user unknown	'01'H	unallocated (un-assigned) number	M	
19	'14'H	user busy	'13'H	User already active	M	
20	'15'H	user rejection	'15'H	call rejected	M	
21	'16'H - '1F'H	reserved	-----		X	
22	'20'H	reserved	-----		X	
23	'21'H	external handover not supported	'7F'H	interworking, unspecified	M	
24	'22'H	network parameter missing	'7F'H	interworking, unspecified	M	

Item No	Information element in DECT air interface		Information element in B-ISDN network		Map status	NOTE
	Release Reason		Cause			
25	'23'H	external handover release	'7F'H	interworking, unspecified	M	
26	'24'H - '2F'	reserved	-----		X	
27	'30'H	reserved	-----		X	
28	'31'H	overload	'7F'H	interworking, unspecified	M	
29	'32'H	insufficient resources	'2F'H	resource unavailable, unspecified	M	
30	'33'H	insufficient bearers available	'7F'H	interworking, unspecified	M	
31	'34'H	IWU congestion	'7F'H	interworking, unspecified	M	
32	'35'H - '3F'H	reserved	-----			

5.2.6.20.2 B-ISDN to DECT

Table 54

Item No	Information element in B-ISDN network		Information element in DECT air interface		Map status	NOTE
	Cause		Release Reason			
1	'10'H	normal call clearing	'00'H	normal	M	
2	'4F'H	service or option not implemented, unspecified	'06'H	service not implemented	M	
3	'1F'H	normal, unspecified	'0F'H	unknown	M	
4	'12'H	no user responding	'10'H	user detached	M	
5	'03'H	no route to destination	'11'H	user not in range	M	
6	'01'H	unallocated (un-assigned) number	'12'H	user unknown	M	
7	'11'H	user busy	'14'H	user busy	M	
8	'15'H	call rejected	'15'H	user rejection	M	
9	'2F'H	resource unavailable, unspecified	'32'H	insufficient resources	M	
NOTE: All other B-ISDN cause values are mapped in an <<IWU-TO-IWU>> information element.						

5.2.6.21 Sub-address Type - Type Of Sub-Address

Table 55

Item No	Information element in DECT air interface		Information element in B-ISDN network		Map status	NOTE
	Sub-address type		Type of sub-address			
1	'000'B	NSAP (Recommendation X.213 [47] ISO/IEC8348 [22])	'000'B	NSAP (Recommendation X.213 [47] / ISO/IEC8348 [22])	M	
2	----		'001'B	user-specified ATM endsystem address	I	
3	'010'B	user-specified	'010'B	user-specified	M	

5.2.6.22 Transaction Identifier - Call Reference

5.2.6.22.1 Transaction Flag - Call reference Flag

Table 56

Item No	Information element in DECT air interface		Information element in B-ISDN network		Map status	NOTE
	Transaction flag		Call reference flag			
1	'0'B		'0'B		M	
2	'1'B		'1'B		M	

5.2.6.22.2 Transaction Value - Call Reference

Table 57

Item No	Information element in DECT air interface		Information element in B-ISDN network		Map status	NOTE
	Transaction value		Call reference			
1	0-5		0-5		M	1
2	6		----		X	2
NOTE 1: The transaction value is inserted in octet 2, bit position 5, 6 & 7 of the call reference information element.						
NOTE 2: The use of DECT extended transaction value is prohibited.						

5.2.6.23 Transfer Mode - AAL Type

Table 58

Item No	Information element in DECT air interface		Information element in B-ISDN network		Map status	NOTE
	Transfer mode		AAL type			
1	'00'B	circuit mode	'00000001'B	AAL 1	M	
2	'01'B	packet mode	'00000101'B	AAL 5		TBS
3	'11'B	None	----		I	TBS

5.2.6.24 Transfer Mode - Bearer Class

Table 59

Item No	Information element in DECT air interface		Information element in B-ISDN network		Map status	NOTE
	Transfer mode		Bearer class			
1	'00'B	circuit mode	'00001'B	BCOB-A	M	
2	'01'B	packet mode	'00011'B	BCOB-C		TBS
3	'11'B	None	----	----	I	
4	----	----	'10000'B	BCOB-X	I	

5.2.6.25 Unit Rate - CBR rate

Table 60

Item No	Information element in DECT air interface		Information element in B-ISDN network		Map status	NOTE
	Unit rate		CBR rate			
1	'01'	16 kbit/s steps	----		I	TBS
2	'10'	32 kbit/s steps	----		I	TBS
3	'11'	64 kbit/s steps	'00000001'	n x 64 kbit/s	M	(see note)
4	----		'01000001'	n x 8 kbit/s	I	TBS
NOTE: "unit rate" relates to "rate multiplier" and "cbr rate" relates to "multiplier" (see subclause 5.2.6.19).						

Annex A (informative): Inter-working state machine

A.1 IWU Call Control State Transition Diagram

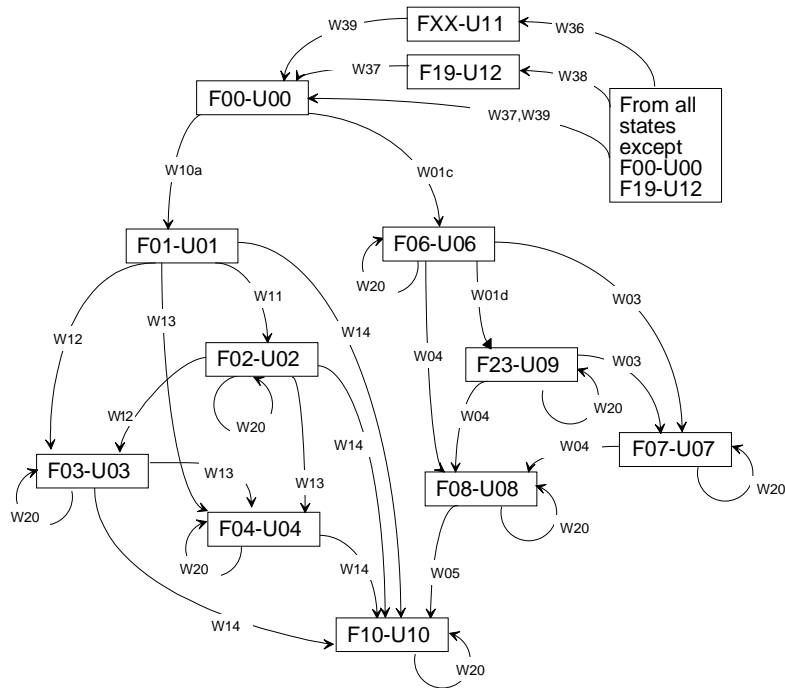

Figure A.1: IWU CC state transition diagram

A.2 IWU Call Control States

All states are a combination of a DECT FT state Fxx and an B-ISDN user state Uyy (i.e. Fxx-Uyy).

A.3 IWU Call Control Transition Procedures

- W01: {SETUP} is received from B-ISDN;
Send {CC-SETUP} to DECT and send { CALL-PROC } to B-ISDN.
- W03: {CC-ALERTING} received from DECT;
Send {ALERTING} to B-ISDN.
- W04: {CC-CONNECT} received from DECT;
Send {CONNECT} to B-ISDN.
- W05: {CONNECT-ACK} is received from B-ISDN;
Send {CC-CONNECT-ACK} to DECT.
- W10a: {CC-SETUP} received from DECT;
Send {SETUP} to B-ISDN.
- W11: {SETUP-ACK} is received from B-ISDN;
Send {CC-SETUP-ACK} to DECT.

- W12: {CALL-PROCEEDING} is received from B-ISDN;
Send {CC-CALL_PROC} to DECT.
- W13: {ALERTING} is received from B-ISDN;
Send {CC-ALERT} to DECT.
- W14: {CONNECT} is received from B-ISDN;
Send {CC-CONNECT} to DECT.
- W20: {INFORMATION} is received from B-ISDN; Send {CC_INFO} to DECT;
or {CC-INFO} is received from DECT; Send {INFORMATION} to B-ISDN.
- W36: {CC-RELEASE} is received from DECT;
Send {RELEASE} to B-ISDN.
- W37: {CC-RELEASE-COM} is received from DECT;
Send {RELEASE-COM} to B-ISDN.
- W38: {RELEASE} is received from B-ISDN;
Send {CC-RELEASE} to DECT.
- W39: {RELEASE-COM} is received from B-ISDN;
Send {CC-RELEASE-COM} to DECT.

Annex B (informative): DECT OVERLAP SENDING in B-ISDN NULL state

The outgoing call procedures with dialling information in DECT OVERLAP SENDING state and B-ISDN NULL state are shown in figure B.1 and figure B.2.

After {CC-SETUP-ACK} has been sent to the DPS, the DFS-IWU then has to wait for dialling information in one or more {CC-INFO} messages. The dialling information can be either in one or more <<KEYPAD>> or in one <<CALLED-PARTY-NUMBER>> information element.

If <<CALLED-PARTY-NUMBER>> information element is used for dialling information, it shall immediately be mapped into B-ISDN <<CALLED-PARTY-NUMBER>> and also <<SENDING-COMPLETE>> information element shall be included in the {SETUP} message.

If <<KEYPAD>> information elements are used for dialling information, then the DFS-IWU shall map the <<KEYPAD>> into <<CALLED-PARTY-NUMBER>> in a {SETUP} message. The DFS-IWU shall map those keys which it can not distinguish to be non-dialling information, i.e. map by default unknown (for the DFS-IWU) keys to <<CALLED-PARTY-NUMBER>>.

The DFS-IWU may collect information in received {CC-INFO} messages. If it does, it shall map all the information in the previously received {CC-INFO} messages and the {CC-SETUP} message into {SETUP}. The {SETUP} shall be sent when an inter-digit IWU timer expires or the DFS-IWU receives a {CC-INFO} message which contains:

- <<CALLED-PARTY-NUMBER>>; or
- the first dialling information which the DFS-IWU does not know if it completes the called party number; or
- dialling information which the DFS-IWU knows that it completes the called party number; or
- <<SENDING-COMPLETE>>.

If <<KEYPAD>> in {CC-INFO} has been used for dialling information, then the B-NT can answer with a {SETUP-ACK}. If the {SETUP-ACK} contains <<PROGRESS-INDICATOR>> then the DFS-IWU shall map {SETUP-ACK} into {CC-INFO} and if it contains <<DISPLAY>> and no <<PROGRESS INDICATOR>> then it may do the mapping. The DFS then has to wait for more dialling information in <<KEYPAD>> in one or more {CC-INFO}.

If the B-NT replies with {CALL-PROC}, {ALERTING} and/or {CONNECT} as responses to {SETUP} or as a result of ISDN overlap sending, then the message(s) shall be mapped to corresponding DECT messages as described in subclause 5.2.4.2, Item No. 2, 1, 3. {CC-CALL-PROC}, {CC-ALERTING} and {CC-CONNECT} shall never be sent before their peer B-ISDN messages have been received. When a {CONNECT} message is received, then the DFS may send a {CONNECT-ACK} back to the network.

If the B-NT replies with {RELEASE} or {RELEASE-COM} as a response to the {SETUP}, then the DFS-IWU shall apply the appropriate release procedures defined in subclauses 5.2.1.3.

When the DFS-CC is in state F-03 or F-04 the DFS-IWU may map all received {CC-INFO} messages into ISDN {INFORMATION} messages as described in subclause 5.2.4.1, Item No. 5.

Upon receipt of a {INFORMATION} message from the B-NT during establishment then the DFS-IWU may map it into a {CC-INFO} as described in subclause 5.2.4.2, Item No. 5.

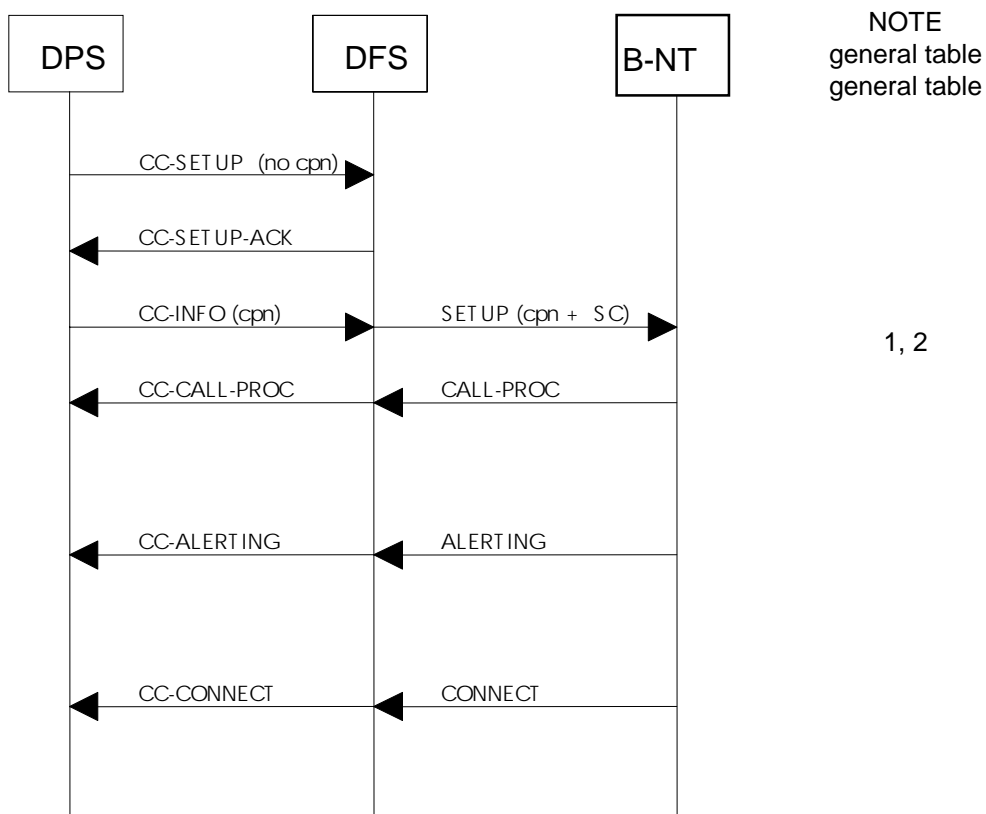

NOTE 1: All information from previously received DECT messages shall be included in the {SETUP} message.

NOTE 2: cpn = <<CALLED-PARTY-NUMBER>>, SC = <<SENDING-COMPLETE>>.

Figure B.1: The DPS sends <<CALLED-PARTY-NUMBER>> in DECT OVERLAP SENDING state and B-ISDN NULL state

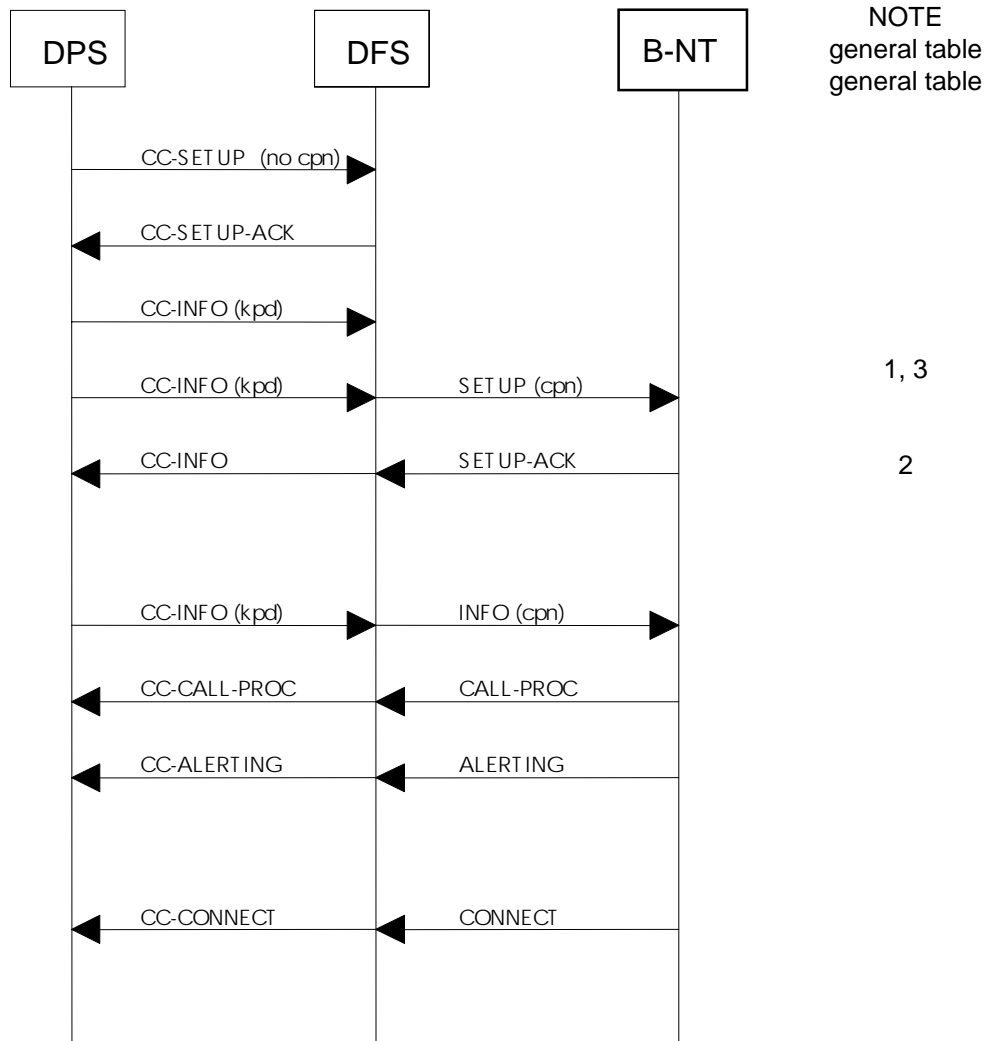

NOTE 1: All information from previously received DECT messages shall be included in the {SETUP} message.

NOTE 2: This message shall be mapped if the message contains <<PROGRESS-INDICATOR>> and optionally mapped if it contains <<DISPLAY>>.

NOTE 3: cpn = <<CALLED-PARTY-NUMBER>>, kpd = <<KEYPAD>> with dialling information.

Figure B.2: The DPS sends <<KEYPAD>> in DECT OVERLAP SENDING state and B-ISDN NULL state (case b)

Bibliography

The following material, though not specifically referenced in the body of the present document (or not publicly available), gives supporting information.

- EN 300 175-1: "Digital Enhanced Cordless Telecommunications (DECT); Common Interface (CI); Part 1: Overview".
- EN 300 175-2: "Digital Enhanced Cordless Telecommunications (DECT); Common Interface (CI); Part 2: Physical Layer (PHL)".
- EN 300 175-3: "Digital Enhanced Cordless Telecommunications (DECT); Common Interface (CI); Part 3: Medium Access Control (MAC) layer".
- EN 300 175-4: "Digital Enhanced Cordless Telecommunications (DECT); Common Interface (CI); Part 4: Data Link Control (DLC) layer".
- EN 300 175-6: "Digital Enhanced Cordless Telecommunications (DECT); Common Interface (CI); Part 6: Identities and addressing".
- EN 300 175-7: "Digital Enhanced Cordless Telecommunications (DECT); Common Interface (CI); Part 7: Security features".
- EN 300 175-8: "Digital Enhanced Cordless Telecommunications (DECT); Common Interface (CI); Part 8: Speech coding and transmission".
- EN 300 052-1: "Integrated Services Digital Network (ISDN); Multiple Subscriber Number (MSN) supplementary service; Digital Subscriber Signalling System No. one (DSS1) protocol; Part 1: Protocol specification".
- EN 300 058-1: "Integrated Services Digital Network (ISDN); Call Waiting (CW) supplementary service; Digital Subscriber Signalling System No. one (DSS1) protocol; Part 1: Protocol specification".
- EN 300 061-1: "Integrated Services Digital Network (ISDN); Subaddressing (SUB) supplementary service; Digital Subscriber Signalling System No. one (DSS1) protocol; Part 1: Protocol specification".
- EN 300 092-1: "Integrated Services Digital Network (ISDN); Calling Line Identification Presentation (CLIP) supplementary service; Digital Subscriber Signalling System No. one (DSS1) protocol; Part 1: Protocol specification".
- EN 300 093-1: "Integrated Services Digital Network (ISDN); Calling Line Identification Restriction (CLIR) supplementary service; Digital Subscriber Signalling System No. one (DSS1) protocol; Part 1: Protocol specification".
- EN 300 097-1: "Integrated Services Digital Network (ISDN); Connected Line Identification Presentation (COLP) supplementary service; Digital Subscriber Signalling System No. one (DSS1) protocol; Part 1: Protocol specification".
- EN 300 098-1: "Integrated Services Digital Network (ISDN); Connected Line Identification Restriction (COLR) supplementary service; Digital Subscriber Signalling System No. one (DSS1) protocol; Part 1: Protocol specification".
- EN 300 130-1: "Integrated Services Digital Network (ISDN); Malicious Call Identification (MCID) supplementary service; Digital Subscriber Signalling System No. one (DSS1) protocol; Part 1: Protocol specification".
- EN 300 138-1: "Integrated Services Digital Network (ISDN); Closed User Group (CUG) supplementary service; Digital Subscriber Signalling System No. one (DSS1) protocol; Part 1: Protocol specification".
- EN 300 141-1: "Integrated Services Digital Network (ISDN); Call Hold (HOLD) supplementary service; Digital Subscriber Signalling System No. one (DSS1) protocol; Part 1: Protocol specification".

- EN 300 182-1: "Integrated Services Digital Network (ISDN); Advice of Charge (AOC) supplementary service; Digital Subscriber Signalling System No. one (DSS1) protocol; Part 1: Protocol specification".
- EN 300 185-1: "Integrated Services Digital Network (ISDN); Conference call, add-on (CONF) supplementary service; Digital Subscriber Signalling System No. one (DSS1) protocol; Part 1: Protocol specification".
- ETS 300 108: "Integrated Services Digital Network (ISDN); Circuit-mode 64 kbit/s unrestricted 8 kHz structured bearer service category; Service description".
- ETS 300 109: "Integrated Services Digital Network (ISDN); Circuit-mode 64 kbit/s 8 kHz structured bearer service category usable for speech information transfer; Service description".
- ETS 300 110: "Integrated Services Digital Network (ISDN); Circuit-mode 64 kbit/s 8 kHz structured bearer service category usable for 3,1 kHz audio information transfer; Service description".
- EN 300 171: "Private Integrated Services Network (PISN); Specification, functional models and information flows; Control aspects of circuit-mode basic services [ISO/IEC 11574 (1994) modified]".
- ETS 300 475-1: "Private Telecommunication Network (PTN); Reference configuration; Part 1: Reference configuration for PTN eXchanges (PTNX) [ISO/IEC 11579-1 (1994), modified]".
- ETS 300 012: "Integrated Services Digital Network (ISDN); Basic user-network interface; Layer 1 specification and test principles".
- ETS 300 402-2: "Integrated Services Digital Network (ISDN); Digital Subscriber Signalling System No. one (DSS1) protocol; Data link layer; Part 2: General protocol specification [ITU-T Recommendation Q.921 [39] (1993), modified]".
- ETS 300 403-1: "Integrated Services Digital Network (ISDN); Digital Subscriber Signalling System No. one (DSS1) protocol; Signalling network layer for circuit-mode basic call control; Part 1: Protocol specification [ITU-T Recommendation Q.931 (1993), modified]".
- EN 300 192: "Private Telecommunication Network (PTN); Signalling protocol at the S-reference point; Circuit mode basic services; ECMA-SSIG-BC".
- EN 300 122-1: "Integrated Services Digital Network (ISDN); Generic keypad protocol for the support of supplementary services; Digital Subscriber Signalling System No. one (DSS1) protocol; Part 1: Protocol specification".
- EN 300 196-1: "Integrated Services Digital Network (ISDN); Generic functional protocol for the support of supplementary services; Digital Subscriber Signalling System No. one (DSS1) protocol; Part 1: Protocol specification".
- EN 300 188-1: "Integrated Services Digital Network (ISDN); Three-Party (3PTY) supplementary service; Digital Subscriber Signalling System No. one (DSS1) protocol; Part 1: Protocol specification".
- EN 300 207-1: "Integrated Services Digital Network (ISDN); Diversion supplementary services; Digital Subscriber Signalling System No. one (DSS1) protocol; Part 1: Protocol specification".
- EN 300 210-1: "Integrated Services Digital Network (ISDN); Freephone (FPH) supplementary service; Digital Subscriber Signalling System No. one (DSS1) protocol; Part 1: Protocol specification".
- EN 300 286-1: "Integrated Services Digital Network (ISDN); User-to-User Signalling (UUS) supplementary service; Digital Subscriber Signalling System No. one (DSS1) protocol; Part 1: Protocol specification".
- EN 300 359-1: "Integrated Services Digital Network (ISDN); Completion of Calls to Busy Subscriber (CCBS) supplementary service; Digital Subscriber Signalling System No. one (DSS1) protocol; Part 1: Protocol specification".
- EN 300 369-1: "Integrated Services Digital Network (ISDN); Explicit Call Transfer (ECT) supplementary service; Digital Subscriber Signalling System No. one (DSS1) protocol; Part 1: Protocol specification".
- EN 300 064-1: "Integrated Services Digital Network (ISDN); Direct Dialling In (DDI) supplementary service; Digital Subscriber Signalling System No. one (DSS1) protocol; Part 1: Protocol specification".

- EN 300 267-1: "Integrated Services Digital Network (ISDN); Telephony 7 kHz, videotelephony, audiographic conference and videoconference teleservices; Digital Subscriber Signalling System No. one (DSS1) protocol; Part 1: Protocol specification".
- ETR 043: "Digital Enhanced Cordless Telecommunications (DECT); Common Interface (CI); Services and facilities requirements specification".
- ETR 015: "Digital Enhanced Cordless Telecommunications (DECT); Reference document".
- ITU-T Recommendation G.821: "Error performance of an international digital connection forming part of an integrated services digital network".
- EN 300 011: "Integrated Services Digital Network (ISDN); Primary rate user-network interface; Layer 1 specification and test principles".
- ITU-T Recommendation G.711: "Pulse code modulation (PCM) of voice frequencies".
- ITU-T Recommendation Q.931: "Digital subscriber Signalling System No. 1 (DSS1) - ISDN user-network interface layer 3 specification for basic call control".
- ITU-T Recommendations Q.601 to Q.699: "Interworking of Signalling Systems - General considerations".
- EN 300 195-1: "Integrated Services Digital Network (ISDN); Supplementary service interactions; Digital Subscriber Signalling System No. one (DSS1) protocol; Part 1: Protocol specification".
- ITU-T Recommendation G.726: "40, 32, 24, 16 kbit/s adaptive differential pulse code modulation (ADPCM)".
- ITU-T Recommendation I.411: "ISDN user-network interfaces - Reference configurations".

History

Document history		
V1.1.1	July 1999	Publication