

**Specification of Dual Tone Multi-Frequency (DTMF)  
Transmitters and Receivers;  
Part 4: Receivers for use in Terminal Equipment for  
end-to-end signalling**

---



---

**Reference**

DTS/ATA-005083-4

---

**Keywords**

Signalling, DTMF, PSTN

**ETSI**

650 Route des Lucioles  
F-06921 Sophia Antipolis Cedex - FRANCE

---

Tel.: +33 4 92 94 42 00 Fax: +33 4 93 65 47 16

Siret N° 348 623 562 00017 - NAF 742 C  
Association à but non lucratif enregistrée à la  
Sous-Préfecture de Grasse (06) N° 7803/88

---

**Important notice**

---

Individual copies of the present document can be downloaded from:  
<http://www.etsi.org>

The present document may be made available in more than one electronic version or in print. In any case of existing or perceived difference in contents between such versions, the reference version is the Portable Document Format (PDF). In case of dispute, the reference shall be the printing on ETSI printers of the PDF version kept on a specific network drive within ETSI Secretariat.

Users of the present document should be aware that the document may be subject to revision or change of status. Information on the current status of this and other ETSI documents is available at <http://www.etsi.org/tb/status/>

If you find errors in the present document, send your comment to:  
[editor@etsi.fr](mailto:editor@etsi.fr)

---

**Copyright Notification**

---

No part may be reproduced except as authorized by written permission.  
The copyright and the foregoing restriction extend to reproduction in all media.

© European Telecommunications Standards Institute 2000.  
All rights reserved.

---

# Contents

Intellectual Property Rights .....	4
Foreword .....	4
1 Scope .....	5
2 References .....	5
3 Definitions, symbols and abbreviations .....	5
3.1 Definitions .....	5
3.2 Symbols .....	6
3.3 Abbreviations .....	6
4 The receiver for TE to TE signalling .....	6
4.1 Area of application .....	6
4.2 Operate and non-operate requirements .....	6
4.2.1 Signal condition requirements .....	6
4.2.1.1 Valid signal .....	7
4.2.1.2 Invalid signal .....	7
4.2.2 Digit Recognition Condition (DRC) requirements .....	8
4.3 Speech immunity performance .....	8
4.4 Electrical characteristics .....	9
<b>Annex A (normative): Speech immunity test signal .....</b>	<b>10</b>
<b>Annex B (informative): Example test signal .....</b>	<b>12</b>
History .....	13

---

## Intellectual Property Rights

IPRs essential or potentially essential to the present document may have been declared to ETSI. The information pertaining to these essential IPRs, if any, is publicly available for **ETSI members and non-members**, and can be found in SR 000 314: "*Intellectual Property Rights (IPRs); Essential, or potentially Essential, IPRs notified to ETSI in respect of ETSI standards*", which is available from the ETSI Secretariat. Latest updates are available on the ETSI Web server (<http://www.etsi.org/ipr>).

Pursuant to the ETSI IPR Policy, no investigation, including IPR searches, has been carried out by ETSI. No guarantee can be given as to the existence of other IPRs not referenced in SR 000 314 (or the updates on the ETSI Web server) which are, or may be, or may become, essential to the present document.

---

## Foreword

This Technical Specification (TS) has been produced by ETSI Project Analogue Terminals and Access (ATA).

The present document is part 4 of a multi-part deliverable covering the Specification of Dual Tone Multi-Frequency (DTMF) Transmitters and Receivers, as identified below:

Part 1: "General";

Part 2: "Transmitters";

Part 3: "Receivers";

**Part 4: "Receivers for use in Terminal Equipment for end-to-end signalling".**

---

# 1 Scope

The present document specifies the Dual Tone Multi-Frequency (DTMF) signalling system.

The various parts of the present document provide a complete set of requirements for all applications intending to use DTMF signalling.

The present document is intended to provide the level of detail that will enable manufacturers of telecommunications equipment incorporating DTMF signalling, to design the equipment such that it facilitates highly reliable signalling. This should not be taken to imply that any DTMF signalling system that fails to meet all the criteria described in the present document will not provide reliable signalling.

The present document is not intended to be used for the definition of regulated interfaces.

This Part 4 covers the requirements for the DTMF receiver for the case of DTMF signalling during an established call from TE to TE.

---

# 2 References

The following documents contain provisions, which, through reference in this text, constitute provisions of the present document.

- References are either specific (identified by date of publication, edition number, version number, etc.) or non-specific.
- For a specific reference, subsequent revisions do not apply.
- For a non-specific reference, the latest version applies.
- A non-specific reference to an ETS shall also be taken to refer to later versions published as an EN with the same number.

- [1] ETSI TBR 21: "Terminal Equipment (TE); Attachment requirements for pan-European approval for connection to the analogue Public Switched Telephone Networks (PSTNs) of TE (excluding TE supporting the voice telephony service) in which network addressing, if provided, is by means of Dual Tone Multi-Frequency (DTMF) signalling".

---

# 3 Definitions, symbols and abbreviations

## 3.1 Definitions

For the purposes of the present document, the following terms and definitions apply:

**High group:** signalling frequencies, which have nominal values of 1 209 Hz, 1 336 Hz, 1 477 Hz and 1 633 Hz

**Low group:** signalling frequencies, which have nominal values of 697 Hz, 770 Hz, 852 Hz and 941 Hz

**Line Input:** The point where the 2 wire line is terminated on the host equipment

**Digit Recognition Condition:** The Digit Recognition Condition (DRC) is defined as the output state of the receiver in response to a valid input signal when the relevant signal condition and time requirements are satisfied

**Valid Signal Condition:** the Valid Signal Condition is defined as the state of the line at the input of the receiver when:

- 1) one of the frequency combinations specified in part 1 and;
- 2) within the frequency tolerances specified in subclause 4.2.1.1, item a) and;

- 3) within the range of acceptable signalling levels specified in subclause 4.2.1, items b) and c) and;
- 4) within the specified limits of any unwanted frequencies as specified in subclause 4.2.1, item d) of the present document.

## 3.2 Symbols

For the purposes of the present document, the following symbols apply:

*	The Star on the standard 3x4 keypad array, also known as the asterisk.
#	The Square on the standard 3x4 keypad array, also known as the hash, sharp, or number sign ("pound" in the USA).
dBV	Absolute voltage level expressed in decibels relative to 1 volt.

## 3.3 Abbreviations

For the purposes of the present document, the following abbreviations apply:

ADSI	Analogue Display Services Interface
DTMF	Dual Tone Multi-Frequency
SDSS	Server Display and Script Services
TE	Terminal Equipment
VSC	Valid Signal Condition

---

# 4 The receiver for TE to TE signalling

## 4.1 Area of application

The present part of the standard deals with the receiver or receiver function for DTMF signalling incorporated into TE. This implies that the receiver needs to be capable of dealing with both the frequency related attenuation as a result of two local loops and the exchanges and interconnecting trunk circuits as well as any changes in frequency that might be introduced by the equipment used by the network provider(s).

The receiver shall respond to signals received over a line from a distant transmitter conforming to parts 1 and 2 of the present document.

The receiver shall be equipped to recognize the sixteen signals designated 0 to 9, \*, #, A, B, C and D. The system may be utilized with only, ten discrete signals, in which case the signals designated 0 to 9, should be used; or with twelve discrete signals, in which case the signals 0 to 9, \*, # should be used. In the interests of system security, the receiver may be conditioned to recognize only specific digits from the complete set of sixteen digits.

NOTE: The principal uses of the receiver as dealt with in the present part 4 of the standard are expected to be:

- (a) in TE receiving signals from a remote TE e.g. remote control of an answering/recording machine;
- (b) in TE receiving signals from equipment such as an SDSS (ADSI) based server. This may be connected so as not to introduce the extra attenuation of the second local connection.

## 4.2 Operate and non-operate requirements

### 4.2.1 Signal condition requirements

The following clauses define the conditions under which the DTMF function shall decide to indicate or not indicate to the host equipment the digit that is represented by a received signal. There will be some conditions that fall into neither

of these two states and the designer of the DTMF function can make their own decision whether such signals are best considered valid or not valid.

#### 4.2.1.1 Valid signal

The received DTMF signal shall be detected as valid when only two of the signalling frequencies are present at the line input, one from the high group and one from the low group which meet the conditions described in items a) to c). This signal shall also be detected as valid if even accompanied by other frequency components described in item d).

- a) Each of these signalling frequencies is within  $\pm (1,5\% + 2)$  Hz of the nominal value; and
- b) The level of each of these two signalling frequencies is within the range -43 dBV to -5 dBV; and
- c) The difference in level of these two signalling frequencies is not more than 10 dB; and
- d) Frequencies not exceeding:
  - i) in the frequency range 300 to 480 Hz a level of -43 dBV. Also where dial tone protection has been provided in the receiver, a total signal level limit of -5 dBV shall additionally apply in the range 100 Hz to 480 Hz to cover interference from this source;
  - ii) in the frequency range 480 Hz to 3 400 Hz a total power level of 20 dB below the level of the low group signalling frequency;
  - iii) at frequencies over 3 400 Hz, an individual signal level of -36 dBV at 3 400 Hz rising at 6 dB per octave to a level of +10 dBV.

NOTE 1: In subclause 4.2.1.1 b), a dynamic range of 38 dB is specified to take into account tolerances in the send levels of the DTMF transmitter and also variations in attenuation found in connections via various networks.

NOTE 2: It is pointed out that some equipment may require protection to cover interference from specified sources, e.g. meter pulses. This may be in addition to that specified in subclause 4.2.1.1 d), item iii).

#### 4.2.1.2 Invalid signal

The received DTMF signal shall be considered as invalid if any of the conditions given in items a) to c) are satisfied at the line input.

- a) the signal levels are correct for valid signals but more than two of the signalling frequencies are present; or
- b) the level of the signalling frequency in the low group (as defined in part 1 of the present standard) is less than -48 dBV; or
- c) the level of the signalling frequency in the high group (as defined in part 1 of the present standard) is less than -48 dBV.

As an aid to the understanding of the subclauses 4.2.1.1 and 4.2.1.2, table 1 is given:

**Table 1: Signal condition requirements**

Signal condition	Frequency deviation (Hz)	Signal level x (dBV)	Signal level difference y (dB)	Unwanted frequencies z (dBV)
<b>Is valid</b>	$\leq \pm (1,5\% + 2)$	$-43 \leq x \leq -5$	$y \leq 10$	$z \leq \Psi$
<b>May be valid</b>	$> \pm (1,5\% + 2)$	$-48 \leq x \leq -43$ or $x > -5$	$y \geq 10$	$z > \Psi$
<b>Invalid</b>		$x < -48$		

$\Psi$  see subclause 4.2.1.1 d) items i) to iii).

NOTE: It is realized that certain electrical signals may exist on the line at the input of the receiver which do not fulfil either the requirements of the '*Is valid*' row or those of the '*Invalid*' row. In these circumstances, the requirements for the existence or non-existence of signal condition are not specified directly, but indirectly, through the speech immunity requirements of subclause 4.3.

## 4.2.2 Digit Recognition Condition (DRC) requirements

If a valid signal present at the line input fulfils the conditions set out in items a) and b) then the digit shall be indicated as recognized.

- a) the signal condition shall be preceded by the continuous absence of a valid signal condition for more than 40 ms or (optionally) by a recognized digit that is different to the current digit; and
- b) the signal condition shall then exist continuously for more than 40 ms.

If a valid signal at the line input has been present for less than 20 ms, the digit shall not be indicated as recognized.

Once the DRC exists, it shall be unaffected by disturbances having a duration of less than 20 ms.

Thus a detected digit that subsequently has interruptions that are less than 20 ms, shall be interpreted as a single digit.

As an aid to the understanding of subclause 4.2.2, table 2 is given:

**Table 2: Digit recognition condition requirements**

Character recognition	When <i>not DRC</i> * and then	Character recognition	When <i>DRC</i> and then
<b>Shall exist</b>	VSC > 40 ms	<b>Shall cease</b>	Not VSC > 40 ms
<b>May exist</b>	$20 \leq \text{VSC} \leq 40$ ms	<b>May cease</b>	$20 \leq \text{Not VSC} \leq 40$ ms
<b>Shall not exist</b>	VSC < 20 ms	<b>Shall not cease</b>	Not VSC < 20 ms

\* or optionally a different character recognition condition

Legend:

- VSC        The continuous existence of signal condition.
- Not VSC    The continuous non-existence of signal condition.
- DRC        The existence of digit recognition condition.
- Not DRC    The non-existence of digit recognition condition.

## 4.3 Speech immunity performance

The receiver should not perform more than 46 false operations per 100 speech hours at a long term active speech level of -16 dBV (-14 dBm0 for digital subscriber lines).

A speech hour is defined as a total duration of one hour when speech (in both directions) may, be present, that is when the circuit is seized and the call established (conversation condition).

NOTE 1: In addition to the simulation of signals by speech entering via the microphone, mis-operation may also be caused by disturbances preventing detection of valid signals and or splitting them into double digits. The design of a receiver with very high rejection efficiency against signal imitation might lead to an intolerable increase in the number of blockings. The general design aim should be to limit both types of mis-operation (imitation and blocking) to a total level not exceeding one per 10 000 digits dialled.

NOTE 2: The duration of 100 hours has been given as the recommended test duration but sufficient accuracy can be achieved by using 10 speech hours, which can be further reduced by applying the time compression procedure described in Annex A.

For test of the speech immunity performance or for comparison between different receivers the test specified in Annex A can be used.



## 4.4 Electrical characteristics

NOTE: The electrical characteristics of the interface will be determined by the apparatus into which the function of the DTMF Receiver has been incorporated.

---

## Annex A (normative): Speech immunity test signal

The speech immunity performance of the receiver is tested by means of a standardized common test signal.

The common standardized test signal is a collection of speech "bursts" which simulate characters on a reference receiver when applied at the NTP. The reference unprotected receiver is defined in Figure A.1 and in the notes to Figure A.1.

Each time the receiver recognizes a false digit, the corresponding section of speech signal is sampled, the sampling window length being in the range from 100 ms to 200 ms, equally distributed before and after the false digit recognition instant.

The duration of the pauses included between the sampled bursts shall range between 150 ms and 300 ms.

The original speech source used for generating the test sequence shall include speech samples from at least four of the following languages: English, French, German, Italian and Spanish, and shall contain both female and male voices.

Based on the available experience, the processing of 10 hours of speech material results in a test signal of about 20 minutes. When this test signal is used, no more than 5 false operations shall occur when it is applied to the DTMF receiver.

The test sequence shall include a 1 kHz calibration tone with a level 12 dB higher than the active speech level of the speech burst sequence.

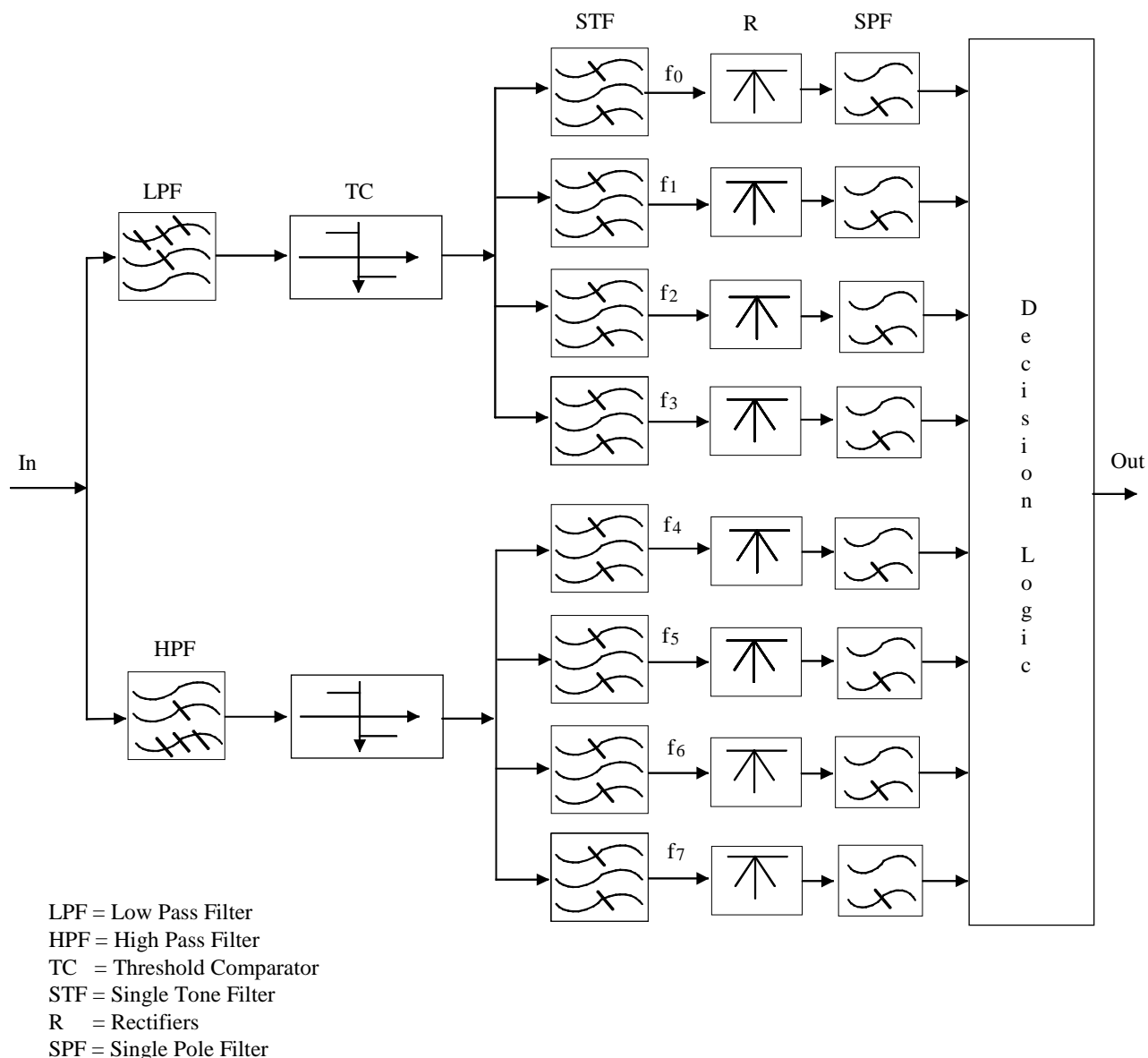

**Figure A.1: Reference unprotected exchange receiver (Block diagram)**

Notes to Figure A.1:

The scheme of the reference unprotected exchange receiver is given in Figure A.1.

The characteristics of the components are:

- low-pass filter  $F \leq 960$  Hz;
- high-pass filter  $F \geq 1\,190$  Hz;
- two threshold comparators;
- eight channel filters (two pole filters:  $-1,5$  dB band pass limits at the nominal frequency  $\pm (1,5\% + 2$  Hz));
- eight rectifiers;
- eight single pole (RC) filters, time constant  $C=4-5$  ms.

The thresholds and decision logic are regulated in order not to recognize character signals with a level below  $-30$  dBm and to recognize valid character signals with a level in the range of  $-4$  dBm to  $-30$  dBm.

No other protections are to be provided in the receiver.

---

## Annex B (informative): Example test signal

One example of a test signal suitable for DTMF receivers has been developed by CSELT a subsidiary of TELECOM ITALIA.

For further information please contact:

**CSELT** - Centro Studi e Laboratori Telecomunicazioni  
Research Collaboration and Standardisation Dept.  
Via Guglielmo Reiss Romoli, 274  
10148 TORINO  
ITALY  
<http://www.cselt.it>  
e-mail: [giancarlo.pirani@cselt.it](mailto:giancarlo.pirani@cselt.it)

---

## History

<b>Document history</b>		
V1.1.1	May 2000	Publication