

ETSI TS 101 162 V1.4.1 (2011-05)

Technical Specification

Digital Video Broadcasting (DVB); Allocation of identifiers and codes for Digital Video Broadcasting (DVB) systems



Reference

RTS/JTC-DVB-298

Keywordsbroadcasting, digital, DVB, MPEG, service, TV,
video**ETSI**

650 Route des Lucioles
F-06921 Sophia Antipolis Cedex - FRANCE

Tel.: +33 4 92 94 42 00 Fax: +33 4 93 65 47 16

Siret N° 348 623 562 00017 - NAF 742 C
Association à but non lucratif enregistrée à la
Sous-Préfecture de Grasse (06) N° 7803/88

Important notice

Individual copies of the present document can be downloaded from:

<http://www.etsi.org>

The present document may be made available in more than one electronic version or in print. In any case of existing or perceived difference in contents between such versions, the reference version is the Portable Document Format (PDF). In case of dispute, the reference shall be the printing on ETSI printers of the PDF version kept on a specific network drive within ETSI Secretariat.

Users of the present document should be aware that the document may be subject to revision or change of status. Information on the current status of this and other ETSI documents is available at

<http://portal.etsi.org/tb/status/status.asp>

If you find errors in the present document, please send your comment to one of the following services:

http://portal.etsi.org/chaicor/ETSI_support.asp

Copyright Notification

No part may be reproduced except as authorized by written permission.
The copyright and the foregoing restriction extend to reproduction in all media.

© European Telecommunications Standards Institute 2011.

© European Broadcasting Union 2011.

All rights reserved.

DECTTM, **PLUGTESTS**TM, **UMTS**TM, **TIPHON**TM, the TIPHON logo and the ETSI logo are Trade Marks of ETSI registered for the benefit of its Members.

3GPPTM is a Trade Mark of ETSI registered for the benefit of its Members and of the 3GPP Organizational Partners.

LTETM is a Trade Mark of ETSI currently being registered for the benefit of its Members and of the 3GPP Organizational Partners.

GSM[®] and the GSM logo are Trade Marks registered and owned by the GSM Association.

Contents

Intellectual Property Rights	5
Foreword.....	5
1 Scope	6
2 References	6
2.1 Normative references	6
2.2 Informative references.....	6
3 Definitions and abbreviations.....	8
3.1 Definitions.....	8
3.2 Abbreviations	8
4 Principles of registration	8
4.1 Registration domain and application domains.....	9
5 Service Information (DVB-SI) identifiers.....	9
5.1 Bouquet_ID	9
5.1.1 Bouquet_ID registration template.....	10
5.1.2 Bouquet_ID allocation template	10
5.1.3 Bouquet_ID domain names	10
5.2 CA_System_ID	10
5.2.1 CA_System_ID registration template	10
5.2.2 CA_System_ID allocation template	11
5.2.3 CA_System_ID domain names.....	11
5.3 CP_System_ID	11
5.3.1 CP_System_ID registration template.....	12
5.3.2 CP_System_ID allocation template	12
5.3.3 CP_System_ID domain names	12
5.4 Country Code	12
5.4.1 Country Code registration template	13
5.4.2 Country Code allocation template	13
5.4.3 Country Code domain names.....	13
5.5 Encoding_Type_ID	13
5.5.1 Encoding_Type_ID registration template.....	14
5.5.2 Encoding_Type_ID allocation template	14
5.5.3 Encoding_Type_ID domain names.....	14
5.6 Network_ID.....	14
5.6.1 Network_ID registration template	15
5.6.2 Network_ID allocation template	15
5.6.3 Network_ID domain names	16
5.7 Original_Network_ID	17
5.7.1 Original_Network_ID registration template	17
5.7.2 Original_Network_ID allocation template.....	17
5.7.3 Original_Network_ID domain names.....	18
5.8 Private_Data_Specifier_ID.....	18
5.8.1 Private_Data_Specifier_ID registration template	18
5.8.2 Private_Data_Specifier_ID allocation template.....	18
5.8.3 Private_Data_Specifier_ID domain names.....	19
6 Data Broadcast (DVB-DATA) identifiers.....	19
6.1 Data_Broadcast_ID	19
6.1.1 Data_Broadcast_ID registration template.....	19
6.1.2 Data_Broadcast_ID allocation template	19
6.1.3 Data_Broadcast_ID domain names.....	20
6.2 Platform_ID.....	20
6.2.1 Platform_ID registration template	21
6.2.2 Platform_ID allocation template.....	21
6.2.3 Platform_ID domain names	21

7	Generic Stream Encapsulation (DVB-GSE) identifiers	22
7.1	Protocol_Type_ID	22
7.1.1	Protocol_Type_ID registration template.....	22
7.1.2	Protocol_Type_ID allocation template	22
7.1.3	Protocol_Type_ID domain names	22
8	Identifiers for Globally Executable MHP (GEM), Multimedia Home Platform (DVB-MHP) and other technologies	23
8.1	MHP_AIT_Descriptor.....	23
8.1.1	MHP_AIT_Descriptor registration template.....	23
8.1.2	MHP_AIT_Descriptor allocation template.....	23
8.1.3	MHP_AIT_Descriptor domain names	24
8.2	MHP_Application_Type_ID	24
8.2.1	MHP_Application_Type_ID registration template.....	25
8.2.2	MHP_Application_Type_ID allocation template	25
8.2.3	MHP_Application_Type_ID domain names	25
8.3	MHP_Organisation_ID	25
8.3.1	MHP_Organisation_ID registration template	26
8.3.2	MHP_Organisation_ID allocation template.....	26
8.3.3	MHP_Organisation_ID domain names.....	26
8.4	MHP_Protocol_ID.....	26
8.4.1	MHP_Protocol_ID registration template	27
8.4.2	MHP_Protocol_ID allocation template.....	27
8.4.3	MHP_Protocol_ID domain names.....	27
9	DVB services over bi-directional IP networks (DVB-IPTV) identifiers	27
9.1	Payload_ID.....	27
9.1.1	Payload_ID registration template	28
9.1.2	Payload_ID allocation template.....	28
9.1.3	Payload_ID domain names	28
10	IP Datacast over DVB (DVB-IPDC) identifiers	28
10.1	IPDC_Operator_ID	28
10.1.1	IPDC_Operator_ID registration template	29
10.1.2	IPDC_Operator_ID allocation template.....	29
10.1.3	IPDC_Operator_ID domain names.....	29
10.2	IPDC_Notification_Type	29
10.2.1	IPDC_Notification_Type registration template	30
10.2.2	IPDC_Notification_Type allocation template.....	30
10.2.3	IPDC_Notification_Type domain names.....	30
10.3	Root_of_Trust_ID	31
10.3.1	Root_of_Trust_ID registration template.....	31
10.3.2	Root_of_Trust_ID allocation template	31
10.3.3	Root_of_Trust_ID domain names.....	31
Annex A (informative):	Example Scenarios for the Utilisation of network_id and original_network_id.....	32
A.1	Re-transmission of a satellite signal in terrestrial networks.....	32
A.2	Re-transmission of a satellite signal in cable networks.....	33
History	34

Intellectual Property Rights

IPRs essential or potentially essential to the present document may have been declared to ETSI. The information pertaining to these essential IPRs, if any, is publicly available for **ETSI members and non-members**, and can be found in ETSI SR 000 314: "*Intellectual Property Rights (IPRs); Essential, or potentially Essential, IPRs notified to ETSI in respect of ETSI standards*", which is available from the ETSI Secretariat. Latest updates are available on the ETSI Web server (<http://webapp.etsi.org/IPR/home.asp>).

Pursuant to the ETSI IPR Policy, no investigation, including IPR searches, has been carried out by ETSI. No guarantee can be given as to the existence of other IPRs not referenced in ETSI SR 000 314 (or the updates on the ETSI Web server) which are, or may be, or may become, essential to the present document.

Foreword

This Technical Specification (TS) has been produced by Joint Technical Committee (JTC) Broadcast of the European Broadcasting Union (EBU), Comité Européen de Normalisation ELECTrotechnique (CENELEC) and the European Telecommunications Standards Institute (ETSI).

NOTE: The EBU/ETSI JTC Broadcast was established in 1990 to co-ordinate the drafting of standards in the specific field of broadcasting and related fields. Since 1995 the JTC Broadcast became a tripartite body by including in the Memorandum of Understanding also CENELEC, which is responsible for the standardization of radio and television receivers. The EBU is a professional association of broadcasting organizations whose work includes the co-ordination of its members' activities in the technical, legal, programme-making and programme-exchange domains. The EBU has active members in about 60 countries in the European broadcasting area; its headquarters is in Geneva.

European Broadcasting Union
CH-1218 GRAND SACONNEX (Geneva)
Switzerland
Tel: +41 22 717 21 11
Fax: +41 22 717 24 81

The Digital Video Broadcasting Project (DVB) is an industry-led consortium of broadcasters, manufacturers, network operators, software developers, regulatory bodies, content owners and others committed to designing global standards for the delivery of digital television and data services. DVB fosters market driven solutions that meet the needs and economic circumstances of broadcast industry stakeholders and consumers. DVB standards cover all aspects of digital television from transmission through interfacing, conditional access and interactivity for digital video, audio and data. The consortium came together in 1993 to provide global standardisation, interoperability and future proof specifications.

1 Scope

The present document defines codes, and identifiers (also referred to as code points) used in DVB systems. These codes are allocated by the DVB Project Office at the request of potential service providers and once allocated, become part of EN 300 468 [i.1] by reference. Further details can be obtained by contacting DVB Services Sàrl.

DVB Services Sàrl
c/o EBU L'Ancienne Route 17a
CH-1218 Grand-Saconnex
Switzerland
Tel: +41 22 717 27 19
Email: info@dvbservices.com
Web: <http://www.dvbservices.com>

2 References

References are either specific (identified by date of publication and/or edition number or version number) or non-specific. For specific references, only the cited version applies. For non-specific references, the latest version of the reference document (including any amendments) applies.

Referenced documents which are not found to be publicly available in the expected location might be found at <http://docbox.etsi.org/Reference>.

NOTE: While any hyperlinks included in this clause were valid at the time of publication ETSI cannot guarantee their long term validity.

2.1 Normative references

The following referenced documents are necessary for the application of the present document.

Not applicable.

2.2 Informative references

The following referenced documents are not necessary for the application of the present document but they assist the user with regard to a particular subject area.

- [i.1] ETSI EN 300 468: "Digital Video Broadcasting (DVB); Specification for Service Information (SI) in DVB systems".
- [i.2] ETSI TS 101 211: "Digital Video Broadcasting (DVB); Guidelines on implementation and usage of Service Information (SI)".
- [i.3] ETSI EN 301 192: "Digital Video Broadcasting (DVB); DVB specification for data broadcasting".
- [i.4] ETSI TR 101 202: "Digital Video Broadcasting (DVB); Implementation guidelines for Data Broadcasting".
- [i.5] ETSI TS 101 812: "Digital Video Broadcasting (DVB); Multimedia Home Platform (MHP) Specification 1.0.3".
- [i.6] ETSI TS 102 727: "Digital Video Broadcasting (DVB); Multimedia Home Platform (MHP) Specification 1.2.2".
- [i.7] ISO 3166-1: "Codes for the representation of names of countries and their subdivisions - Part 1: Country codes".
- [i.8] ETSI TS 102 606: "Digital Video Broadcasting (DVB); Generic Stream Encapsulation (GSE) Protocol".

- [i.9] CENELEC EN 50221: "Common Interface Specification for Conditional Access and other Digital Video Broadcasting Decoder Applications".
- [i.10] ETSI TS 102 323: "Digital Video Broadcasting (DVB); Carriage and signalling of TV-Anytime information in DVB transport streams".
- [i.11] ETSI TS 102 034: "Digital Video Broadcasting (DVB); Transport of MPEG-2 TS Based DVB Services over IP Based Networks".
- [i.12] ETSI TS 102 006: "Digital Video Broadcasting (DVB); Specification for System Software Update in DVB Systems".
- [i.13] ETSI TS 102 771: "Digital Video Broadcasting (DVB); Generic Stream Encapsulation (GSE) implementation guidelines".
- [i.14] ETSI TS 102 539: "Digital Video Broadcasting (DVB); Carriage of Broadband Content Guide (BCG) information over Internet Protocol (IP)".
- [i.15] ETSI TS 102 824: "Digital Video Broadcasting (DVB); Remote Management and Firmware Update System for DVB IPTV Services (Phase 2)".
- [i.16] ETSI TS 102 832: "Digital Video Broadcasting (DVB); IP Datacast over DVB-H: Notification Framework".
- [i.17] ETSI TS 102 611-1: "Digital Video Broadcasting (DVB); IP Datacast: Implementation Guidelines for Mobility; Part 1: IP Datacast over DVB-H".
- [i.18] ETSI TS 102 474: "Digital Video Broadcasting (DVB); IP Datacast over DVB-H: Service Purchase and Protection".
- [i.19] CableLabs: "OpenCable Application Platform Specifications; OCAP 1.1 Profile; OC-SP-OCAP1.1.3-100603".
- NOTE: <http://www.cablelabs.com/specifications/OC-SP-OCAP1.1.3-100603.pdf>.
- [i.20] ATSC A/101: "Advanced Common Application Platform (ACAP)".
- NOTE: http://www.atsc.org/cms/standards/a_101a.pdf.
- [i.21] Open IPTV Forum: "OIPF Release 1 Specification Volume 3 - Content Metadata".
- NOTE: http://www.oipf.tv/docs/Release1/Release1_1/OIPF-T1-R1-Specification-Volume-3-Content-Metadata-V1_1-2009-10-08.pdf.
- [i.22] Open IPTV Forum: "OIPF Release 1 Specification Volume 5 - Declarative Application Environment".
- NOTE: http://www.oipf.tv/docs/Release1/Release1_1/OIPF-T1-R1-Specification-Volume-5-Declarative-Application-Environment-V1_1-2009-10-08.pdf.
- [i.23] Open IPTV Forum: "OIPF Release 1 Specification Volume 6 - Procedural Application Environment".
- NOTE: http://www.oipf.tv/docs/Release1/Release1_1/OIPF-T1-R1-Specification-Volume-6-Procedural-Application-Environment-V1_1-2009-10-08.pdf.
- [i.24] ETSI TS 102 809: "Digital Video Broadcasting (DVB); Signalling and carriage of interactive applications and services in Hybrid broadcast/broadband environments".
- [i.25] ETSI ES 202 184: "MHEG-5 Broadcast Profile".
- [i.26] ETSI TS 102 728: "Digital Video Broadcasting (DVB); Globally Executable MHP (GEM) Specification 1.2.2 (including IPTV)".
- [i.27] ETSI TS 102 471: "Digital Video Broadcasting (DVB); IP Datacast over DVB-H: Electronic Service Guide (ESG)".

3 Definitions and abbreviations

3.1 Definitions

For the purposes of the present document, the following terms and definitions apply:

applicant: organisation which applies for an identifier under the regime of the present document

application domain: identifier namespace constituted by a specification other than the present document

registrar: organisation who keeps a public register of DVB-SI identifiers and assigns new values to Applicants under the regime of the present document

NOTE: By default, the DVB Project Office is the only registrar for DVB-SI identifiers. The Project Office may however pass this task on to one or more third parties.

registration domain: identifier namespace constituted by the present document

3.2 Abbreviations

For the purposes of the present document, the following abbreviations apply:

AIT	Application Information Table
CA	Conditional Access
CP	Copy Protection
DVB	Digital Video Broadcasting
DVBSTP	DVB SD&S Transport Protocol

NOTE: See TS 102 539 [i.14].

ESG	Electronic Service Guide
-----	--------------------------

NOTE: See TS 102 471 [i.27].

GEM	Globally Executable MHP
GSE	Generic Stream Encapsulation
ID	IDentity
IP	Internet Protocol
IPDC	IP Datacast
MAC	Medium Access Control
MHP	Multimedia Home Platform
NIT	Network Information Table

NOTE: See EN 300 468 [i.1].

PKI	Public-Key Infrastructure
SI	Service Information
SPP	Service Purchase and Protection

NOTE: See TS 102 474 [i.18].

TS	Transport Stream
----	------------------

NOTE: See EN 300 468 [i.1].

4 Principles of registration

The present document defines the allocation of identifiers pertaining to different DVB specifications (e.g. MHP, SI, Data Broadcasting, etc.). It does not describe the detail or the template as to how this should be done. The aim of the present document is to provide assistance to those soliciting and allocating identifiers.

Each identifier has the following attributes:

- 1) It is **defined** in a DVB specification (e.g. DVB Service Information (EN 300 468 [i.1])).
- 2) It is either:
 - a) **a binary number** represented by either its hexadecimal equivalent denoted by the prefix "0x", or its decimal equivalent; or
 - b) **a string constant** represented by its Unicode equivalent; or
 - c) **a combination of a binary number and a string constant.**
- 3) It **has a text description**. It is the table of values and descriptions which is published on www.dvb.org.
- 4) It is **allocated to an organisation** operating in the digital television space (e.g. ACME Digital Broadcasting, Inc.), or a grouping of such companies (e.g. an ACME - Association of Cable/MMDS Enterprises) or an institution acting in digital television, e.g. IEEE (Institute of Electrical and Electronic Engineers).
- 5) It **may be allocated for a given region**. For terrestrial broadcasting, this is typically a sovereign country; for satellite operations, this is typically a geographical region spanning many countries, but consistent with the footprint of the satellites owned by the operators.

The present document describes where to find definitions of each identifier, who to refer to when there are questions, templates for the allocations and rules governing them. In addition, and where appropriate, there are descriptions of best practice and some historical notes.

The DVB Project Office shall be the only Registrar entitled to accept applications and perform registrations under the regime of the present document, and within the application areas of the specifications listed in clause 2.1. The DVB Project Office shall maintain a public, on-line register of assigned identifiers to ease quick look-up of the current assignments.

NOTE: For practical reasons, the DVB Project Office may choose to delegate the operation and maintenance of the public, on-line register and the authority of receiving applications and performing registrations to one or more third parties.

4.1 Registration domain and application domains

The scope of the present document shall constitute a registration domain namespace. Referred to as the registration domain for short. All identifiers defined in the present document are assigned a name in the registration domain.

Other specification documents - as referenced by the present document - constitute their own application domain namespaces. Each of them referred to as an application domain for short. Different names may be used for referring to the identifiers defined in the present document, in these application domains.

For each of the identifiers defined in the present document, a sub-clause is provided, which lists the registration domain name, and application domain names used to refer to the respective identifier. This means that all the names listed for each identifier, refer to one and the same identifier. Consequently, all provisions made in the present document for the respective identifier, shall also apply to the application domains listed.

5 Service Information (DVB-SI) identifiers

This clause and its sub-clauses cover the identifiers defined in EN 300 468 [i.1].

5.1 Bouquet_ID

Bouquet_ID values shall be allocated to broadcasters and network operators to identify bouquets within the application area of EN 300 468 [i.1], by insertion in the bouquet_id field.

5.1.1 Bouquet_ID registration template

To register a Bouquet_ID, applicants shall supply at least the information labelled as "required" in the registration template below.

Table 1: Bouquet_ID registration template

Registration field	Required	Description
Bouquet Name	required	Name of the Bouquet (e.g. "ACME Pay-TV Service")
Bouquet Country Code	required	Country code where the bouquet is unique (e.g. North America)
Bouquet Operator	required	Name of organisation which operates Bouquet (e.g. "ACME Pay-TV, Inc.")
Bouquet Legal Contact	required	Name and e-mail of authorised legal signatory of "Bouquet Operator"
Bouquet Technical Contact	required	Name and e-mail of technical contact of "Bouquet Operator"
Bouquet Notes	optional	Notes on the application, e.g. last revised and what revisions were made

5.1.2 Bouquet_ID allocation template

The scheme and values given in table 2 shall be used for the allocation of Bouquet_ID values.

Table 2: Bouquet_id allocation template

Bouquet_ID	Description
0x0000	Reserved
0x0001 to 0xFFFF	Reserved for general registration through the DVB Project Office (see http://www.dvbservices.com)

5.1.3 Bouquet_ID domain names

Table 3 lists the names, under which the bouquet_id is used in different DVB specifications.

Table 3: Bouquet_ID domain names

Name	Domain	Description
Bouquet_ID	Registration Domain	Constituted by the present document
bouquet_id	DVB-SI	EN 300 468 [i.1] TS 101 211 [i.2]
bouquet_id	DVB-DATA	EN 301 192 [i.3] TR 101 202 [i.4]
bouquet_id	DVB-TVA	TS 102 323 [i.10]
bouquetId	DVB-MHP	TS 101 812 [i.5] TS 102 727 [i.6] TS 102 809 [i.24] TS 102 728 [i.26]

5.2 CA_System_ID

CA_System_ID values shall be allocated to Conditional Access system vendors to identify CA systems within the application area of EN 300 468 [i.1], by insertion in the CA_system_id field.

5.2.1 CA_System_ID registration template

To register a CA_System_ID, applicants shall supply at least the information labelled as "required" in the registration template below.

Table 4: CA_System_ID registration template

Registration field	Required	Description
CA System Name	required	Name of the organisation supplying Conditional Access services (e.g. "ACME CA Services, Inc.")
CA System Legal Contact	required	Name and e-mail of authorised legal signatory of "CA System Name"
CA System Technical Contact	required	Name and e-mail of technical contact of "CA System Name"
CA System Notes	optional	Notes on the application, e.g. last revised and what revisions were made

5.2.2 CA_System_ID allocation template

The scheme and values given in table 5 shall be used for the allocation of CA_System_ID values.

Table 5: CA_System_ID allocation template

CA_System_ID	CA system specifier
0x0000	Reserved
0x0001 to 0x00FF	Reserved for registration to standardised systems through the DVB Project Office (see http://www.dvbservices.com)
0x0100 to 0xFFFF	Reserved for general registration through the DVB Project Office (see http://www.dvbservices.com)

In the standardised systems registration range, allocations shall only be made for Conditional Access systems which are defined and/or adopted as such by DVB, and which are fully described in a publicly available document from a recognised standardisation body.

In the general registration range, allocations shall only be made to bona fide Conditional Access system vendors. Applicants need to demonstrate that the vendor is proposing a registration for a legitimate Conditional Access product.

5.2.3 CA_System_ID domain names

Table 6 lists the names, under which the CA_System_ID is used in different DVB specifications.

Table 6: CA_System_ID domain names

Name	Domain	Description
CA_System_ID	Registration Domain	Constituted by the present document
CA_system_id	DVB-SI	EN 300 468 [i.1] TS 101 211 [i.2]
CA_system_id	DVB-DATA	EN 301 192 [i.3] TR 101 202 [i.4]
CA_system_id	DVB-TVA	TS 102 323 [i.10]
CASystemId	DVB-MHP	TS 101 812 [i.5] TS 102 727 [i.6] TS 102 809 [i.24] TS 102 728 [i.26]

5.3 CP_System_ID

CP_System_ID values shall be allocated to identify Copy Protection (CP) systems to which DVB-CPCM content will be exported within the application area of EN 300 468 [i.1], by insertion in the field CP_system_id.

5.3.1 CP_System_ID registration template

To register a CP_System_ID, applicants shall supply at least the information labelled as "required" in the registration template below.

Table 7: CP_System_ID registration template

Registration field	Required	Description
CP System Description	required	Name of a Content Protection System (e.g. "ACME Content Safe 1.0")
CP System Specifier	required	Name of the organisation supplying the CPS (e.g. "ACME CPS Consortium")
CP System Legal Contact	required	Name and e-mail of authorised legal signatory of "CP System Specifier"
CP System Technical Contact	required	Name and e-mail of technical contact of "CP System Specifier"
CP System Notes	optional	Notes on the application, e.g. last revised and what revisions were made

5.3.2 CP_System_ID allocation template

The scheme and values given in table 8 shall be used for the allocation of CP_System_ID values.

Table 8: CP_System_ID allocation template

CP_System_ID	CP system specifier
0x0000 to 0x00FF	Reserved for registration to systems defined by DVB
0x0000	DVB CPCM Content Licence
0x0001	DVB CPCM Auxiliary Data
0x0002	DVB CPCM Revocation List
0x0100 to 0xFFFF	Reserved for general registration through the DVB Project Office (see http://www.dvbservices.com)

In the general registration range, allocations shall only be made to bona fide Copy Protection system vendors. Applicants need to demonstrate that the vendor is proposing a registration for a legitimate Copy Protection product.

5.3.3 CP_System_ID domain names

Table 9 lists the names, under which the CP_System_ID is used in different DVB specifications.

Table 9: CP_system_id domain names

Name	Domain	Description
CP_System_ID	Registration Domain	Constituted by the present document
CP_system_id	DVB-SI	EN 300 468 [i.1] TS 101 211 [i.2]

5.4 Country Code

Country Code values shall be allocated to geographical areas to identify groups of countries or parts of countries within the application area of EN 300 468 [i.1]. These are supplementary to ISO 3166-1 [i.7]. This identifier helps in defining geographical coverage of other identifiers.

5.4.1 Country Code registration template

To register a Country Code, applicants shall supply at least the information labelled as "required" in the registration template below.

Table 10: Country Code registration template

Registration field	Required	Description
Geographical Area Name	required	Name of the geographical area (e.g. "North America")
Geographical Area Legal Contact	required	Name and e-mail of authorised legal signatory of "Geographical Area Name"
Geographical Area Technical Contact	required	Name and e-mail of technical contact of "Geographical Area Name"
Geographical Area Notes	optional	Notes on the application, e.g. last revised and what revisions were made

5.4.2 Country Code allocation template

The scheme and values given in table 11 shall be used for the allocation of Country Code values.

Table 11: Country Code allocation template

Country Code	Grouping
000 to 899	Reserved for ISO 3166-1 [i.7] use
900 to 999	Reserved for registration through the DVB Project Office (see http://www.dvbservices.com)

Since geographical areas are to be represented by this identifier, allocations of Country Code values shall only be made to bona fide organisations. Applicants need to demonstrate that they represent the geographical area in question in an appropriate way. Preferred Applicants for Country Code values are hence organisations known to be in agreement with the legal and regulatory authorities, and other determining organisations active in, or substantially affected by, the area for which a Country Code value is to be registered.

5.4.3 Country Code domain names

Table 12 lists the names, under which the Country Code is used in different DVB specifications.

Table 12: Country Code domain names

Name	Domain	Description
Country Code	Registration Domain	Constituted by the present document
country_code	DVB-SI	EN 300 468 [i.1] TS 101 211 [i.2]

5.5 Encoding_Type_ID

Encoding_Type_ID values shall be allocated to broadcasters, network operators and content producers to identify string encodings within the application area of EN 300 468 [i.1], by insertion in the field encoding_type_id in the second byte of the string.

5.5.1 Encoding_Type_ID registration template

To register an Encoding_Type_ID, applicants shall supply at least the information labelled as "required" in the registration template below.

Table 13: Encoding_Type_ID registration template

Registration field	Required	Description
Encoding Type Description	required	Name of a character encoding type (e.g. "ACME Universal Character Set 3")
Encoding Type Specifier	required	Name of the organisation which is responsible for the character set described above (e.g. "ACME Fonts, Inc.")
Encoding Type Legal Contact	required	Name and e-mail of authorised legal signatory of "Encoding Type ID"
Encoding Type Technical Contact	required	Name and e-mail of technical contact of "Encoding Type ID"
Encoding Type Notes	optional	Notes on the application, e.g. last revised and what revisions were made

5.5.2 Encoding_Type_ID allocation template

The scheme and values given in table 14 shall be used for the allocation of Encoding_Type_ID values.

Table 14: Encoding_Type_ID allocation template

Encoding_Type_ID	CP system specifier
0x00	Reserved
0x01 to 0xEF	Reserved for general registration through the DVB Project Office (see http://www.dvbservices.com)
0xF0 to 0xFF	Reserved for future use

5.5.3 Encoding_Type_ID domain names

Table 15 lists the names, under which the Encoding_Type_ID is used in different DVB specifications.

Table 15: Encoding_type_id domain names

Name	Domain	Description
Encoding_Type_ID	Registration Domain	Constituted by the present document
encoding_type_id	DVB-SI	EN 300 468 [i.1] TS 101 211 [i.2]

5.6 Network_ID

Network_ID values shall be allocated to broadcasters and network operators to identify networks within the application area of EN 300 468 [i.1], by insertion in the network_id field.

A network is defined as a collection of MPEG 2 Transport Stream (TS) multiplexes transmitted on a single delivery system, e.g. all digital channels on a specific cable system. Network_IDs are unique within the geographical region defined by the Country Code.

- For satellite networks, this is a region spanning many countries.
- For a cable network, this is a single country.
- For terrestrial networks, this is a single country also, but it is important that two adjacent countries shall not have the same block of Network IDs. Hence the concept of colour coding countries was introduced.

5.6.1 Network_ID registration template

To register a Network_ID, applicants shall supply at least the information labelled as "required" in the registration template below.

Table 16: Network_ID registration template

Registration field	Required	Description
Network Type	required	Satellite, terrestrial or cable
Network Name	required	Name of the Network (e.g. "ACME Cable")
Network Country Code	required	Country code where the network is unique (e.g. North America)
Network Operator	required	Name of organisation which operates the network (e.g. "ACME Pay-TV, Inc.")
Network Legal Contact	required	Name and e-mail of authorised legal signatory of "Network Operator"
Network Technical Contact	required	Name and e-mail of technical contact of "Network Operator"
Network Notes	optional	Notes on the application, e.g. last revised and what revisions were made

The rules for the allocation of Network_IDs are as follows:

- 1) Network_ID s will be allocated on a geographical basis such that no conflict of network ids occurs in any geographical region. (Satellite network ids will be unique world-wide).
- 2) Network_IDs are a scarce resource and their allocation is under responsibility of DVB. Application of multiple Network_IDs is subject to exhaustive verification and is discouraged.
- 3) 256 Network_ID values are reserved for private/temporary use. Their allocation is not subject of the present document.
- 4) Network_IDs will be allocated according to clause 5.6.2.
- 5) Network_IDs for the terrestrial delivery medium will be made available to the appropriate national telecommunications regulator and their allocation in each country is under responsibility of this regulator.
- 6) In order to avoid the uneconomical use of Network_IDs, the values will be given in blocks of 256 values on a country by country basis. Non-allocated Network_IDs will be kept reserved.
- 7) The allocation of terrestrial network ids shall be based on a 4-colour-map approach. Two blocks of 256 values are reserved for the eventual case of collision.
- 8) If 256 values are not sufficient for a country, a new block of 256 colours will be allocated. This block can be used by all countries with the same colour in the colour map.

NOTE: Due to the re-usable allocation of all types of Network_ID values (satellite, cable and terrestrial), no link between Network_ID and Original_Network_ID exists.

5.6.2 Network_ID allocation template

The scheme and values given in table 17 shall be used for the allocation of Network_ID values.

Table 17: Network_ID allocation template

Network_ID	Classification	Network Type	Country code(s) of validity	Description
0x0000	Reserved	all	all	Reserved
0x0001 to 0x2000	Unique satellite	Satellite	all	4 096 values reserved for registration through the DVB Project Office (see http://www.dvbservices.com)
0x2001 to 0x3000	Unique terrestrial	Terrestrial	all	4 096 values reserved for registration through the DVB Project Office (see http://www.dvbservices.com)
0x3001 to 0x3600	Re-useable terrestrial	Terrestrial	as registered	1 536 values reserved for registration through the DVB Project Office (see http://www.dvbservices.com)
0x3001 to 0x3100	Countries of colour A	Terrestrial	as registered	256 values
0x3101 to 0x3200	Countries of colour B	Terrestrial	as registered	256 values
0x3201 to 0x3300	Countries of colour C	Terrestrial	as registered	256 values
0x3301 to 0x3400	Countries of colour D	Terrestrial	as registered	256 values
0x3401 to 0x3500	Countries of colour E	Terrestrial	as registered	256 values (to be used only in case of collision)
0x3501 to 0x3600	Countries of colour F	Terrestrial	as registered	256 values (to be used only in case of collision)
0x3601 to 0xA000	Reserved for future use	Terrestrial	to be defined	27 136 values reserved for registration through the DVB Project Office (see http://www.dvbservices.com)
0xA001 to 0xB000	Re-useable cable	Cable	as registered	4 096 values reserved for registration through the DVB Project Office (see http://www.dvbservices.com)
0xB001 to 0xF000	Reserved for future use	Cable	to be defined	16 384 values reserved for registration through the DVB Project Office (see http://www.dvbservices.com)
0xF001 to 0xFF00	Unique cable	Cable	all	3 840 values reserved for registration through the DVB Project Office (see http://www.dvbservices.com)
0xFEC0 to 0xFF00	Network Interface Modules	DVB Common Interface [i.9]	all	64 values for local use by DVB-CI modules
0xFF01 to 0xFFFF	Temporary private use	Not defined	all	255 values for temporary private use

5.6.3 Network_ID domain names

Table 18 lists the names, under which the Network_ID is used in different DVB specifications.

Table 18: Network_ID domain names

Name	Domain	Description
Network_ID	Registration Domain	Constituted by the present document
network_id	DVB-SI	EN 300 468 [i.1] TS 101 211 [i.2]
network_id	DVB-DATA	EN 301 192 [i.3] TR 101 202 [i.4] TS 102 006 [i.12]
network_id	DVB-TVA	TS 102 323 [i.10]
networkId	DVB-MHP	TS 101 812 [i.5] TS 102 727 [i.6] TS 102 809 [i.24] TS 102 728 [i.26]

5.7 Original_Network_ID

Original_Network_ID values shall be allocated to broadcasters, network operators and content producers to uniquely identify networks within the application area of EN 300 468 [i.1], by insertion in the original_network_id field.

5.7.1 Original_Network_ID registration template

To register an Original_Network_ID, applicants shall supply at least the information labelled as "required" in the registration template below.

Table 19: Original_Network_ID registration template

Registration field	Required	Description
Original Network Name	required	Name of the Network (e.g. "ACME TV")
Original Network Operator	required	Name of organisation which operates network (e.g. "ACME Broadcast Corp.")
Original Network Legal Contact	required	Name and e-mail of authorised legal signatory of "Original Network Operator"
Original Network Technical Contact	required	Name and e-mail of technical contact of "Original Network Operator"
Original Network Notes	optional	Notes on the application, e.g. last revised and what revisions were made

The rules for the allocation of Original_Network_IDs are as follows:

- 1) In principle only one Original_Network_ID should be assigned to each network operator, broadcaster or content producer.
- 2) Original_Network_IDs are a scarce resource and their allocation is under responsibility of DVB. Application of multiple Original_Network_IDs is subject to exhaustive verification and discouraged.
- 3) 256 Original_Network_ID values are reserved for private/temporary use. Their allocation is not subject of the present document.

Since terrestrial and cable networks have in most cases a clearly identified geographical region of validity, the re-usage of Network_IDs is possible. However, Original_Network_IDs shall be unique independent of geographical region, since they are used to uniquely identify the transport streams and services.

In terrestrial networks, however it is recommended that all operators within a country use the same Original_Network_ID. This implies that broadcasters and operators within a country would need to coordinate the allocation of transport_stream_ids and service_ids between them. The registrar is recommended to allocate Original_Network_ID values for terrestrial operators on the basis of Country Code + 0x2000. This will help receivers to discriminate broadcasts from multiple countries in cases where the target region descriptor is not used.

Some examples on the use of Network_ID and Original_Network_ID are given in Annex A.

5.7.2 Original_Network_ID allocation template

The scheme and values given in table 20 shall be used for the allocation of Original_Network_ID values.

Table 20: Original_Network_ID allocation template

Original_Network_ID	Description
0x0000	Reserved
0x0001 to 0xFEBF	Reserved for general registration through the DVB Project Office (see http://www.dvbservices.com)
0xFEC0 to 0xFF00	DVB Common Interface Modules [i.9]
0xFF00 to 0xFFFF	Private temporary use

5.7.3 Original_Network_ID domain names

Table 21 lists the names, under which the Original_Network_ID is used in different DVB specifications.

Table 21: Original_Network_ID domain names

Name	Domain	Description
Original_Network_ID	Registration Domain	Constituted by the present document
original_network_id	DVB-SI	EN 300 468 [i.1] TS 101 211 [i.2]
original_network_id	DVB-DATA	EN 301 192 [i.3] TR 101 202 [i.4] TS 102 006 [i.12]
original_network_id	DVB-TVA	TS 102 323 [i.10]
originalNetworkId	DVB-MHP	TS 101 812 [i.5] TS 102 727 [i.6] TS 102 809 [i.24] TS 102 728 [i.26]

5.8 Private_Data_Specifier_ID

Private_Data_Specifier_ID values shall be allocated to broadcasters, manufacturers and network operators and content producers to identify private SI elements within the application area of EN 300 468 [i.1], by insertion in the private_data_specifier field.

5.8.1 Private_Data_Specifier_ID registration template

To register a Private_Data_Specifier_ID, applicants shall supply at least the information labelled as "required" in the registration template below.

Table 22: Private_Data_Specifier_ID registration template

Registration field	Required	Description
Private Data Specifier Organisation	required	Name of the organisation or organisation which is responsible for the private codes (e.g. "ACME, Inc.")
Private Data Specifier Legal Contact	required	Name and e-mail of authorised legal signatory of "Private Data Specifier Organisation"
Private Data Specifier Contact	required	Name and e-mail of technical contact of "Private Data Specifier Organisation"
Private Data Specifier Notes	optional	Notes on the application, e.g. last revised and what revisions were made

Since the Private_Data_Specifier_ID plays important roles in national broadcast regulations and service aggregation, being able correctly identify the origins of the private data is important. Hence, Private_Data_Specifier_ID values shall only be allocated to bona fide organisations for which there is a legal signatory.

5.8.2 Private_Data_Specifier_ID allocation template

The scheme and values given in table 23 shall be used for the allocation of Private_Data_Specifier_ID values.

Table 23: Private_Data_Specifier_ID allocation template

Private_Data_Specifier_ID	Description
0x00000000	Reserved
0x00000001 to 0xFFFFFFFF	Reserved for general registration through the DVB Project Office (see http://www.dvbservices.com)

5.8.3 Private_Data_Specifier_ID domain names

Table 24 lists the names, under which the Private_Data_Specifier_ID is used in different DVB specifications.

Table 24: Private_data_specifier domain names

Name	Domain	Description
Private_Data_Specifier_ID	Registration Domain	Constituted by the present document
private_data_specifier	DVB-SI	EN 300 468 [i.1] TS 101 211 [i.2]
private_data_specifier	DVB-DATA	EN 301 192 [i.3] TR 101 202 [i.4] TS 102 006 [i.12]
private_data_specifier	DVB-MHP	TS 101 812 [i.5] TS 102 727 [i.6] TS 102 809 [i.24] TS 102 728 [i.26]

6 Data Broadcast (DVB-DATA) identifiers

This clause and its sub-clauses cover the identifiers defined in EN 301 192 [i.3].

6.1 Data_Broadcast_ID

Data_Broadcast_ID values shall be allocated to broadcasters, Conditional Access vendors, middleware vendors and other standardisation bodies to identify the types of Data Broadcast services within the application area of EN 300 468 [i.1], by insertion in the field data_broadcast_id.

6.1.1 Data_Broadcast_ID registration template

To register a Data_Broadcast_ID, applicants shall supply at least the information labelled as "required" in the registration template below.

Table 25: Data_Broadcast_ID registration template

Registration field	Required	Description
Data Broadcast Specification Name	required	Name of a Data Broadcast Specification (e.g. "ACMEcast 1.0")
Data Broadcast Specifier	required	Name of the organisation specifying the "Data Broadcast Specification Name" mentioned above (e.g. "ACMEcast, Inc.")
Data Broadcast Legal Contact	required	Name and e-mail of authorised legal signatory of "Data Broadcast Specifier"
Data Broadcast Technical Contact	required	Name and e-mail of technical contact of "Data Broadcast Specifier"
Data Broadcast Notes	optional	Notes on the application, e.g. last revised and what revisions were made

6.1.2 Data_Broadcast_ID allocation template

The scheme and values given in table 26 shall be used for the allocation of Data_Broadcast_ID values.

Table 26: Data_Broadcast_ID allocation template

Data_Broadcast_ID	Data broadcast specification
0x0000	Reserved for future use
0x0001 to 0x00EF	Reserved for registration to DVB data broadcasting
0x0001	Data pipe
0x0002	Asynchronous data stream
0x0003	Synchronous data stream
0x0004	Synchronised data stream
0x0005	Multi protocol encapsulation
0x0006	Data Carousel
0x0007	Object Carousel
0x0008	DVB ATM streams
0x0009	Higher Protocols based on asynchronous data streams
0x000A	System Software Update service [i.12]
0x000B	IP/MAC Notification service [i.3]
0x00F0 to 0x00FF	Reserved for registration to MHP data broadcasting
0x00F0	MHP Object Carousel
0x00F1	MHP Multiprotocol Encapsulation
0x00F2	MHP application presence
0x0100 to 0xFFFF	Reserved for general registration through the DVB Project Office (see http://www.dvbservices.com)
0xFFFF	Reserved for future use

In the general registration range separate allocations for different versions of the same data broadcast specification shall only be made if and when a receiver would otherwise not be able to detect the version used from the contents of the data broadcast streams themselves or from private data carried in DVB-SI descriptors bearing a data_broadcast_id field. Data broadcast specifiers should thus design their specifications such that receivers can detect the version used without the use of separate Data_Broadcast_ID values.

6.1.3 Data_Broadcast_ID domain names

Table 27 lists the names, under which the Data_Broadcast_ID is used in different DVB specifications.

Table 27: Data_Broadcast_ID domain names

Name	Domain	Description
Data_Broadcast_ID	Registration Domain	Constituted by the present document
data_broadcast_id	DVB-SI	EN 300 468 [i.1] TS 101 211 [i.2]
data_broadcast_id	DVB-DATA	EN 301 192 [i.3] TR 101 202 [i.4] TS 102 006 [i.12]
data_broadcast_id	DVB-TVA	TS 102 323 [i.10]
data_broadcast_id	DVB-MHP	TS 101 812 [i.5] TS 102 727 [i.6] TS 102 809 [i.24] TS 102 728 [i.26]

6.2 Platform_ID

Platform_ID values shall be allocated to network operators and IPDC platform operators to uniquely identify the IP/MAC platform in use which is defined in EN 301 192 [i.3], by insertion in the platform_id field.

6.2.1 Platform_ID registration template

To register a Platform_ID, applicants shall supply at least the information labelled as "required" in the registration template below.

Table 28: Platform_ID registration template

Registration field	Required	Description
Platform Name	required	Name of the IP/MAC Platform (e.g. "ACME MobileTV").
Platform Operator	required	Name of organisation which operates IP/MAC Platform (e.g. "ACME Mobile Com, Inc.")
Platform Legal Contact	required	Name and e-mail of authorised legal signatory of "Platform Operator"
Platform Technical Contact	required	Name and e-mail of technical contact of "Platform Operator"
Platform Notes	optional	Notes on the application, e.g. last revised and what revisions were made

6.2.2 Platform_ID allocation template

The scheme and values given in table 29 shall be used for the allocation of Platform_ID values.

Table 29: Platform_ID allocation template

Platform_ID	Description
0x000000	Reserved
0x000001 to 0xFFEFFF	Reserved for general registration through the DVB Project Office (see http://www.dvbservices.com). These platform_id values are globally unique.
0xFFF000 to 0xFFFFFE	Managed by the network operator, and may be used for IP/MAC Platforms supporting services only within a single DVB network. These platform_id values are unique within a network_id only.
0xFFFFF	Reserved

6.2.3 Platform_ID domain names

Table 30 lists the names, under which the Platform_ID is used in different DVB specifications.

Table 30: Platform_ID domain names

Name	Domain	Description
Platform_ID	Registration Domain	Constituted by the present document
platform_id	DVB-SI	EN 300 468 [i.1] TS 101 211 [i.2]
platform_id	DVB-DATA	EN 301 192 [i.3] TR 101 202 [i.4] TS 102 006 [i.12]
platform_id	DVB-MHP	TS 101 812 [i.5] TS 102 727 [i.6] TS 102 809 [i.24] TS 102 728 [i.26]

7 Generic Stream Encapsulation (DVB-GSE) identifiers

This clause and its sub-clauses cover the identifiers defined in TS 102 606 [i.8].

7.1 Protocol_Type_ID

The DVB-S2, -T2 and -C2 physical layers provide Generic Stream modes for conveying arbitrary, variable length payload frames. To identify the type of payload frames, a field in the header of these physical layers is used. For example, in the case of DVB-S2 and DVB-T2, the SYNC field is used. Further details about the fields used can be found in [i.8].

7.1.1 Protocol_Type_ID registration template

To register a Protocol_Type_ID, applicants shall supply at least the information labelled as "required" in the registration template below.

Table 31: Protocol_Type_ID registration template

Registration field	Required	Description
Protocol Type Name	required	Name of protocol specification (e.g. "ACME SkyDSL")
Protocol Type Specifier	required	Name of the organisation or organisation which is responsible for the protocol specification above (e.g. "ACME Sat Coms, Inc.")
Protocol Type Legal Contact	required	Name and e-mail of authorised legal signatory of "Protocol Type ID"
Protocol Type Technical Contact	required	Name and e-mail of technical contact of "Protocol Type ID"
Protocol Type Notes	optional	Notes on the application, e.g. last revised and what revisions were made

7.1.2 Protocol_Type_ID allocation template

The scheme and values given in table 32 shall be used for the allocation of Protocol_Type_ID values.

Table 32: Protocol_Type_ID allocation template

Protocol_Type_ID	Description
0x00	Generic Stream Encapsulation [i.8], [i.13]
0x01	Generic Stream Encapsulation with CRC-32 for DVB-S2 adaptive coding modes [i.8], [i.13]
0x02 to 0xB8	Reserved for registration to standardised protocols through the DVB Project Office (see http://www.dvbservices.com)
0xB9 to 0xFF	User private

7.1.3 Protocol_Type_ID domain names

Table 33 lists the names, under which the Protocol_Type_ID is used in different DVB specifications.

Table 33: Protocol_Type_ID domain names

Name	Domain	Description
Protocol_Type_ID	Registration Domain	Constituted by the present document
protocol_type_id	DVB-GSE	TS 102 606 [i.8] TS 102 771 [i.13]

8 Identifiers for Globally Executable MHP (GEM), Multimedia Home Platform (DVB-MHP) and other technologies

The Application Information Table (AIT) provides full information on the data broadcast, the required activation state of applications carried by it, etc. Although first used with MHP (TS 101 812 [i.5] and TS 102 727 [i.6]), the AIT is now used with other technologies including OCAP [i.19], ACAP [i.20], MHEG-5 [i.25] and various specifications which use TS 102 809 [i.24], for example the Open IPTV Forum specifications [i.21], [i.22] and [i.23]. In many places in the present document, the identifiers retain MHP in the name to reflect their origins but this does not imply limitations on their use with other application types.

8.1 MHP_AIT_Descriptor

8.1.1 MHP_AIT_Descriptor registration template

To register an MHP_AIT_Descriptor, applicants shall supply at least the information labelled as "required" in the registration template below.

Table 34: MHP_AIT_Descriptor registration template

Registration field	Required	Description
AIT Descriptor Specification Name	required	Name of an AIT Descriptor Specification (e.g. "ACME InteractiveApps 1.0")
AIT Descriptor Specifier	required	Name of the organisation specifying the "AIT Descriptor Specification Name" mentioned above (e.g. "ACME TV-Apps, Inc.")
AIT Descriptor Legal Contact	required	Name and e-mail of authorised legal signatory of "AIT Descriptor Specifier"
AIT Descriptor Technical Contact	required	Name and e-mail of technical contact of "AIT Descriptor Specifier"
AIT Descriptor Notes	optional	Notes on the descriptor, e.g. last revised and what revisions were made

8.1.2 MHP_AIT_Descriptor allocation template

The scheme and values given in table 35 shall be used for the allocation of MHP_AIT_Descriptor values.

Table 35: MHP_AIT_Descriptor allocation template

MHP_AIT_Descriptor	Description
0x00 to 0x5F	Reserved for DVB-MHP
0x00	application_descriptor
0x01	application_name_descriptor
0x02	transport_protocol_descriptor
0x03	dvb_j_application_descriptor
0x04	dvb_j_application_location_descriptor
0x05	external_application_authorization_descriptor
0x08	dvb_html_application_descriptor
0x09	dvb_html_application_location_descriptor
0x0A	dvb_html_application_boundary_descriptor
0x0B	application_icons_descriptor
0x0C	prefetch_descriptor
0x0D	DII_location_descriptor
0x0E	delegated_application_descriptor
0x0F	plug-in_descriptor
0x10	application_storage_descriptor
0x11	ip_signalling_descriptor
0x12	provider_export_descriptor
0x13	provider_usage_descriptor
0x14	graphics_constraints_descriptor
0x5F	private_data_specifier_descriptor
0x60 to 0x7F	Reserved for registration to standardised descriptors through the DVB Project Office (see http://www.dvbservices.com)
0x80 to 0xFF	Reserved for future use

8.1.3 MHP_AIT_Descriptor domain names

Table 36 lists the names, under which the MHP_AIT_Descriptor is used in different DVB specifications.

Table 36: MHP_AIT_Descriptor domain names

Name	Domain	Description
MHP_AIT_Descriptor	Registration Domain	Constituted by the present document
descriptor_tag	DVB-MHP	TS 101 812 [i.5] TS 102 727 [i.6] TS 102 809 [i.24] TS 102 728 [i.26]

8.2 MHP_Application_Type_ID

The MHP_Application_Type_ID identifies the type of the applications described in an AIT sub-table, i.e. the engine or plug-in on which the applications can be executed. MHP_Application_Type_ID values shall be allocated to broadcasters, Conditional Access vendors, middleware vendors, and other standardisation bodies to identify the types of interactive applications by insertion in the field application_type.

8.2.1 MHP_Application_Type_ID registration template

To register an MHP_Application_Type_ID, applicants shall supply at least the information labelled as "required" in the registration template below.

Table 37: MHP_Application_Type_ID registration template

Registration field	Required	Description
Application Type Specification Name	required	Name of an Application Type Specification (e.g. "ACME Goldenrod 1.0")
Application Type Specifier	required	Name of the organisation specifying the "Application Type Specification Name" mentioned above (e.g. "ACMEcast, Inc.")
Application Type Legal Contact	required	Name and e-mail of authorised legal signatory of "Application Type Specifier"
Application Type Technical Contact	required	Name and e-mail of technical contact of "Application Type Specifier"
Application Type Notes	optional	Notes on the application type, e.g. last revised and what revisions were made

8.2.2 MHP_Application_Type_ID allocation template

The scheme and values given in table 38 shall be used for the allocation of MHP_Application_Type_ID values.

Table 38: MHP_Application_Type_ID allocation template

MHP_Application_Type_ID	Description
0x0000	Reserved
0x0001	DVB-J application
0x0002	DVB-HTML application
0x0003 to 0x7FFF	Reserved for registration to standardised applications through the DVB Project Office (see http://www.dvbservices.com)

8.2.3 MHP_Application_Type_ID domain names

Table 39 lists the names, under which the MHP_Application_Type_ID is used in different DVB specifications.

Table 39: MHP_Application_Type_ID domain names

Name	Domain	Description
MHP_Application_Type_ID	Registration Domain	Constituted by the present document
application_type	DVB-MHP	TS 101 812 [i.5] TS 102 727 [i.6] TS 102 809 [i.24] TS 102 728 [i.26]

8.3 MHP_Organisation_ID

The MHP_Organisation_ID globally and uniquely identifies an organization that is responsible for interactive applications. MHP_Organisation_ID values shall be allocated to broadcasters, Conditional Access vendors, middleware vendors, application publishers, and other standardisation bodies to identify them as responsible for interactive applications by insertion in the field organisation_id.

8.3.1 MHP_Organisation_ID registration template

To register an MHP_Organisation_ID, applicants shall supply at least the information labelled as "required" in the registration template below.

Table 40: MHP_Organisation_ID registration template

Registration field	Required	Description
Organisation Name	required	Name of the organisation responsible for the interactive Applications (e.g. "ACMEcast, Inc.")
Organisation Legal Contact	required	Name and e-mail of authorised legal signatory of "Organisation Name"
Organisation Technical Contact	required	Name and e-mail of technical contact of "Organisation Name"
Organisation Notes	optional	Notes on the organisation, e.g. legal successor for, or assignee to other Organisation ID holder

8.3.2 MHP_Organisation_ID allocation template

The scheme and values given in table 41 shall be used for the allocation of MHP_Organisation_ID values.

Table 41: MHP_Organisation_ID allocation template

MHP_Organisation_ID	Description
0x000000	Reserved
0x000001 to 0xFFFFFFFF	Reserved for general registration through the DVB Project Office (see http://www.dvbservices.com). These MHP_Organisation_ID values are globally unique.

8.3.3 MHP_Organisation_ID domain names

Table 42 lists the names, under which the MHP_Organisation_ID is used in different DVB specifications.

Table 42: MHP_Organisation_ID domain names

Name	Domain	Description
MHP_Organisation_ID	Registration Domain	Constituted by the present document
organisation_id organization_id organisationId	DVB-MHP	TS 101 812 [i.5] TS 102 727 [i.6] TS 102 809 [i.24] TS 102 728 [i.26]

8.4 MHP_Protocol_ID

The MHP_Protocol_ID identifies a protocol used for carrying interactive applications. MHP_Protocol_ID values shall be allocated to broadcasters, Conditional Access vendors, middleware vendors, and other standardisation bodies to identify protocols for carrying interactive applications by insertion in the field protocol_id.

8.4.1 MHP_Protocol_ID registration template

To register an MHP_Protocol_ID, applicants shall supply at least the information labelled as "required" in the registration template below.

Table 43: MHP_Protocol_ID registration template

Registration field	Required	Description
Protocol Specification Name	required	Name of a Protocol Specification (e.g. "ACMEcast 1.0")
Protocol Specifier	required	Name of the organisation specifying the "Protocol Specification Name" mentioned above (e.g. "ACMEcast, Inc.")
Protocol Legal Contact	required	Name and e-mail of authorised legal signatory of "Protocol Specifier"
Protocol Technical Contact	required	Name and e-mail of technical contact of "Protocol Specifier"
Protocol Notes	optional	Notes on the protocol, e.g. last revised and what revisions were made

8.4.2 MHP_Protocol_ID allocation template

The scheme and values given in table 44 shall be used for the allocation of MHP_Protocol_ID values.

Table 44: MHP_Protocol_ID allocation template

MHP_Protocol_ID	Description
0x0000	Reserved
0x0001 to 0x00FF	Reserved for protocols defined by DVB [i.5], [i.6], [i.24] and [i.26]
0x0001	MHP Object Carousel
0x0002	IP via DVB Multiprotocol Encapsulation
0x0003	HTTP over the interaction channel
0x0100 to 0xFFFF	Reserved for registration to standardised protocols through the DVB Project Office (see http://www.dvbservices.com)

8.4.3 MHP_Protocol_ID domain names

Table 45 lists the names, under which the MHP_Organisation_ID is used in different DVB specifications.

Table 45: MHP_Protocol_ID domain names

Name	Domain	Description
MHP_Protocol_ID	Registration Domain	Constituted by the present document
protocol_id	DVB-MHP	TS 101 812 [i.5] TS 102 727 [i.6] TS 102 809 [i.24] TS 102 728 [i.26]

9 DVB services over bi-directional IP networks (DVB-IPTV) identifiers

9.1 Payload_ID

For the transport of SD&S records, TS 102 034 [i.11] defines the DVBSTP protocol. The different types of SD&S information are distinguished by the Payload_ID field in the DVBSTP header.

9.1.1 Payload_ID registration template

Since no registration to organisations outside DVB is possible at this time, no registration template is given. Should the Payload_ID be opened up for public registration in the future, the required registration template will appear here.

9.1.2 Payload_ID allocation template

The scheme and values given in table 46 shall be used for the allocation of Payload_ID values.

Table 46: Payload_ID allocation template

Payload_ID	Description
0x00	Reserved
0x01 to 0EF	Reserved for payload formats defined by DVB [i.11], [i.14] and [i.15]
0x01	SD&S Service Provider Discovery Information
0x02	SD&S Broadcast Discovery Information
0x03	SD&S COD Discovery Information
0x04	SD&S Services from other SPs
0x05	SD&S Package Discovery Information
0x06	SD&S BCG Discovery Information
0x07	SD&S Regionalisation Discovery Information
0x08	FUS Stub file and SD&S RMS-FUS record
0xA1 to 0xAF	BCG Payload_ID values (defined in TS 102 539 [i.14])
0xB1	CDS XML download session description (defined in TS 102 539 [i.14])
0xB2	RMS-FUS Firmware Update Announcements (defined in TS 102 824 [i.15])
0xC1	Application Discovery Information
0xF0 to 0xFF	User defined

9.1.3 Payload_ID domain names

Table 47 lists the names, under which the Payload_ID is used in different DVB specifications.

Table 47: Platform_id domain names

Name	Domain	Description
Payload_ID	Registration Domain	Constituted by the present document
Payload ID	DVB-IPTV	TS 102 034 [i.11]
payloadId		TS 102 539 [i.14]
PayloadId		TS 102 824 [i.15]

10 IP Datacast over DVB (DVB-IPDC) identifiers

10.1 IPDC_Operator_ID

An IPDC Operator is a network entity managing IPDC key streams. It is uniquely identified by a pair of two DVB identifiers:

- an IPDC_Operator_ID value; and
- a CA_System_ID value (see clause 5.2).

IPDC_Operator_ID values shall be allocated to IPDC operators to construct - under the scope of a CA_system_ID value - the unique identification of an IPDC operator [i.17].

For CA_system_ID values in the range of 0x0001 to 0x00FF (standardised CA systems), associated IPDC_Operator_ID values shall be registered through the DVB Project Office.

10.1.1 IPDC_Operator_ID registration template

To register an IPDC_Operator_ID, applicants shall supply at least the information labelled as "required" in the registration template below.

Table 48: IPDC_Operator_ID registration template

Registration field	Required	Description
IPDC Operator ID Type	required	Type of the IPDC Operator ID to be registered, i.e. string or numerical
IPDC Operator CA System ID	required	The CA_System_id (see clause 5.2) which has already been registered to "IPDC Operator Name", and under which the "IPDC Operator ID" will be used
IPDC Operator Name	required	Name of the organisation supplying Conditional Access services (e.g. "ACME Mobile Services, Inc.")
IPDC Operator Legal Contact	required	Name and e-mail of authorised legal signatory of "IPDC Operator Name"
IPDC Operator Technical Contact	required	Name and e-mail of technical contact of "IPDC Operator Name"
IPDC Operator Notes	optional	Notes on the application, e.g. last revised and what revisions were made
NOTE: For historical reasons, the IPDCOperatorId value actually used in IPDC signalling can either be a numerical value or a string value, depending on the CA system with which it is associated (e.g. IPDC SPP Open Security Framework is traditionally associated with IPDCOperatorId numerical values, whereas IPDC SPP 18Crypt is traditionally associated with IPDCOperatorId string values).		

When a string ID is to be registered, it shall be a unique text string compliant with one of the two XML built-in data types "string" or "anyURI".

10.1.2 IPDC_Operator_ID allocation template

The scheme and values given in table 49 shall be used for the allocation of IPDC_Operator_ID values.

Table 49: Numerical IPDC_Operator_ID allocation template

IPDC_Operator_ID	Description
0x0000	Reserved for non-encrypted services
0x0001 to 0xFFFF	Reserved for general registration through the DVB Project Office (see http://www.dvbservices.com).

10.1.3 IPDC_Operator_ID domain names

Table 50 lists the names, under which the IPDC_Operator_ID is used in different DVB specifications.

Table 50: IPDC_Operator_ID domain names

Name	Domain	Description
IPDC_Operator_ID	Registration Domain	Constituted by the present document
IPDC_Operator_ID IPDCOperatorId	DVB-IPDC	TS 102 832 [i.16] TS 102 611-1 [i.17] TS 102 474 [i.18]

10.2 IPDC_Notification_Type

IPDC Notification is a function by which the network provides messages about forthcoming and not predictable events of interest to the terminal or the user. An IPDC Notification may lead to subsequent interaction from the user/the terminal. The information carried in the notification messages can be related to the (DVB) network supporting the IPDC system, the IP platform, or the services described in a given ESG.

Static, standardised IPDC_Notification_Type values shall be allocated to broadcasters, Conditional Access vendors, middleware vendors, and other standardisation bodies to identify the types of Notification message targeting an IPDC Notification application in the terminal or in the smartcard within the application area of TS 102 832 [i.16], by insertion in the field NotificationType. Allocations shall only be made for Notification Types which are fully described in a publicly available document from a recognized standardization body.

10.2.1 IPDC_Notification_Type registration template

To register an IPDC_Notification_Type, applicants shall supply at least the information labelled as "required" in the registration template below.

Table 51: IPDC_Notification_Type registration template

Registration field	Required	Description
IPDC Notification Type MIME Type	required	MIME type of the application-specific message part
IPDC Notification Type Specification Name	required	Name of a IPDC Notification Type Specification (e.g. "ACME InfoServ 1.0")
IPDC Notification Type Specifier	required	Name of the organisation specifying the "IPDC Notification Type Specification Name" mentioned above (e.g. "ACMEcast, Inc.")
IPDC Notification Legal Contact	required	Name and e-mail of authorised legal signatory of "IPDC Notification Type Specifier"
IPDC Notification Type Technical Contact	required	Name and e-mail of technical contact of "IPDC Notification Type Specifier"
IPDC Notification Type Notes	optional	Notes on the application type, e.g. last revised and what revisions were made

10.2.2 IPDC_Notification_Type allocation template

The scheme and values given in table 52 shall be used for the allocation of IPDC_Notification_Type values.

Table 52: IPDC_Notification_Type allocation template

IPDC_Notification_Type	MIME Type	Description
0x0000 to 0x00FF		Reserved for registration to standardised applications through the DVB Project Office (see http://www.dvbservices.com)
0x0000		Reserved for specific IPDC signalling
0x0001	text/xml	ESG update message
0x0002	application/octet-stream	Notification application inside the smartcard, invoked by the OMA Smart Card Web Server
0x0100 to 0xFFFF		User defined (dynamically assigned in the scope of an IP platform)

10.2.3 IPDC_Notification_Type domain names

Table 53 lists the names, under which the IPDC_Notification_Type is used in different DVB specifications.

Table 53: IPDC_Notification_Type domain names

Name	Domain	Description
IPDC_Notification_Type	Registration Domain	Constituted by the present document
NotificationType	DVB-IPDC	TS 102 832 [i.16] TS 102 611-1 [i.17] TS 102 474 [i.18]

10.3 Root_of_Trust_ID

The 18Crypt profile of DVB-IPDC Service Purchase and Protection (SPP) uses a public-key infrastructure (PKI) to manage authorisation, authentication, data integrity, and certificate revocations. The Root_of_Trust_ID globally and uniquely identifies a trust-centre organization that is responsible for issuing and managing certificates [i.18].

Root_of_Trust_ID values shall be allocated only to bona fide trust-centre organisations. Applicants need to demonstrate that the vendor is proposing a registration for a legitimate Root-of-Trust product.

10.3.1 Root_of_Trust_ID registration template

To register a Root_of_Trust_ID, applicants shall supply at least the information labelled as "required" in the registration template below.

Table 54: Root_of_Trust_ID registration template

Registration field	Required	Description
Root of Trust Name	required	Name of the organisation supplying trust-centre services (e.g. "ACME Trust Centre, Inc.")
Root of Trust Legal Contact	required	Name and e-mail of authorised legal signatory of "Root of Trust Name"
Root of Trust Technical Contact	required	Name and e-mail of technical contact of "Root of Trust Name"
Root of Trust Notes	optional	Notes on the application, e.g. last revised and what revisions were made

10.3.2 Root_of_Trust_ID allocation template

The scheme and values given in table 55 shall be used for the allocation of Root_of_Trust_ID values.

Table 55: Root_of_Trust_ID allocation template

Root_of_Trust_ID	CA system specifier
000 to 001	Reserved for registration to systems defined by DVB
002 to 999	Reserved for general registration through the DVB Project Office (see http://www.dvbservices.com)

10.3.3 Root_of_Trust_ID domain names

Table 56 lists the names, under which the Root_of_Trust_ID is used in different DVB specifications.

Table 56: Root_of_Trust_ID domain names

Name	Domain	Description
Root_of_Trust_ID	Registration Domain	Constituted by the present document
rot_id	DVB-IPDC	TS 102 832 [i.16] TS 102 611-1 [i.17] TS 102 474 [i.18]

Annex A (informative): Example Scenarios for the Utilisation of network_id and original_network_id

A.1 Re-transmission of a satellite signal in terrestrial networks

A service operator A-TV transmits his transport stream to satellite X-SAT. The signal is re-transmitted by the terrestrial network A-NET in country A with modifications to the content. The signal is re-transmitted by the terrestrial network in country B without modifications to the content:

- A-TV has the unique original_network_id 0x1234.
- Another television network B-TV (original_network_id = 0x5678) is using the same satellite for the contribution to A-Net in country A and to B-Net in country B.
- The original_network_id of a DVB-T network is very likely to be the one given for that country according to table 1 of this TR. The originating service operator and its original_network_id in this case do not occur in the NIT of terrestrial networks.
- X-SAT has the network_id 0x0200 (in range of unique satellite networks).
- A-NET and B-Net share the re-usable terrestrial network_id range of 0x3300 to 0x334F.

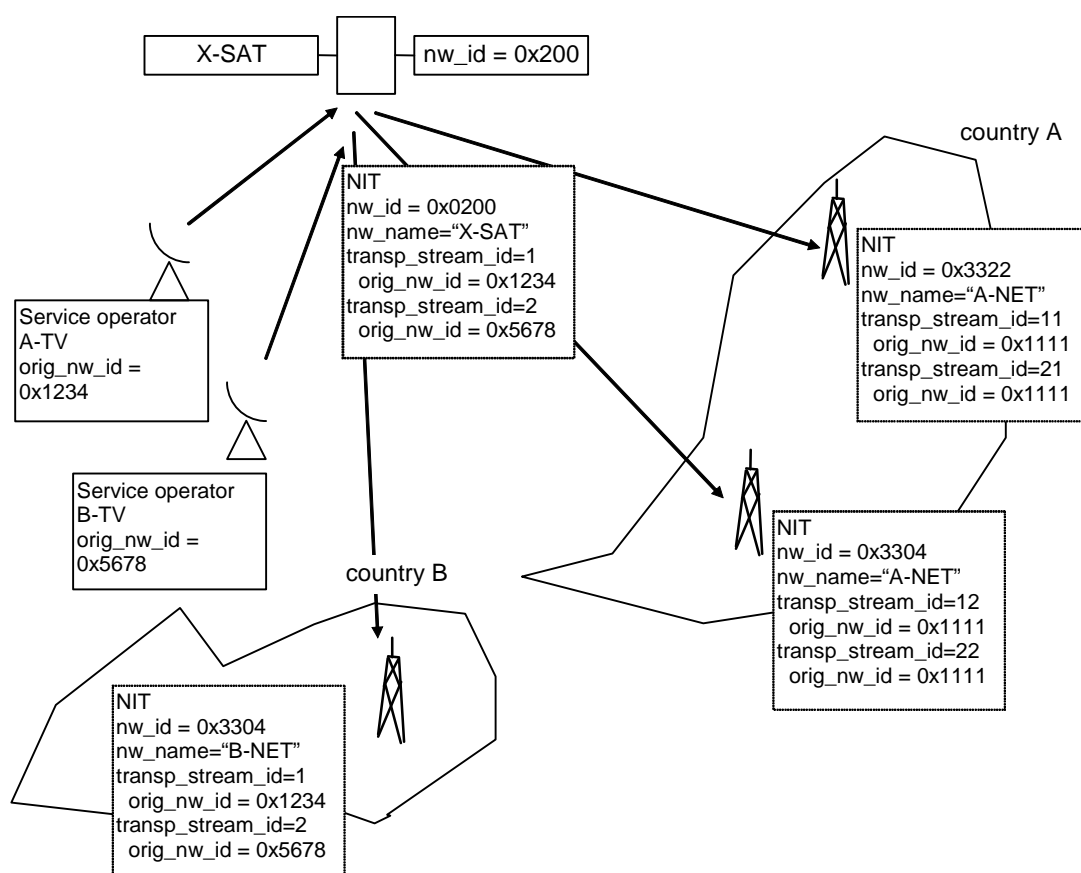

Figure A.1

The satellite NIT contains the original_network_id of A-TV and the network_id of X-SAT.

On the terrestrial network the original_network_id has always the value that has been allocated for a certain country as defined in clause 5.6. The network_id is replaced by one of the network_ids of country A that could be re-used in country B if it has the same colour in the colour-map.

A.2 Re-transmission of a satellite signal in cable networks

The same scheme as above applies. Cable networks generally use re-usable network_ids because there is no risk that IRDs are connected to two cable networks sharing the same network_id at the same time.

The satellite serves different cable networks in L-Town and in E-Town. They can use the same network_id because they are physically separated.

A special case is the transmission of cable network NITs as "foreign" NITs on a satellite. In this case the cable network_ids have to be in the unique range of values since a collision on other networks using the same re-usable network_id cannot be guaranteed. **Note that this method is not recommended since the number of unique network_ids is limited.**

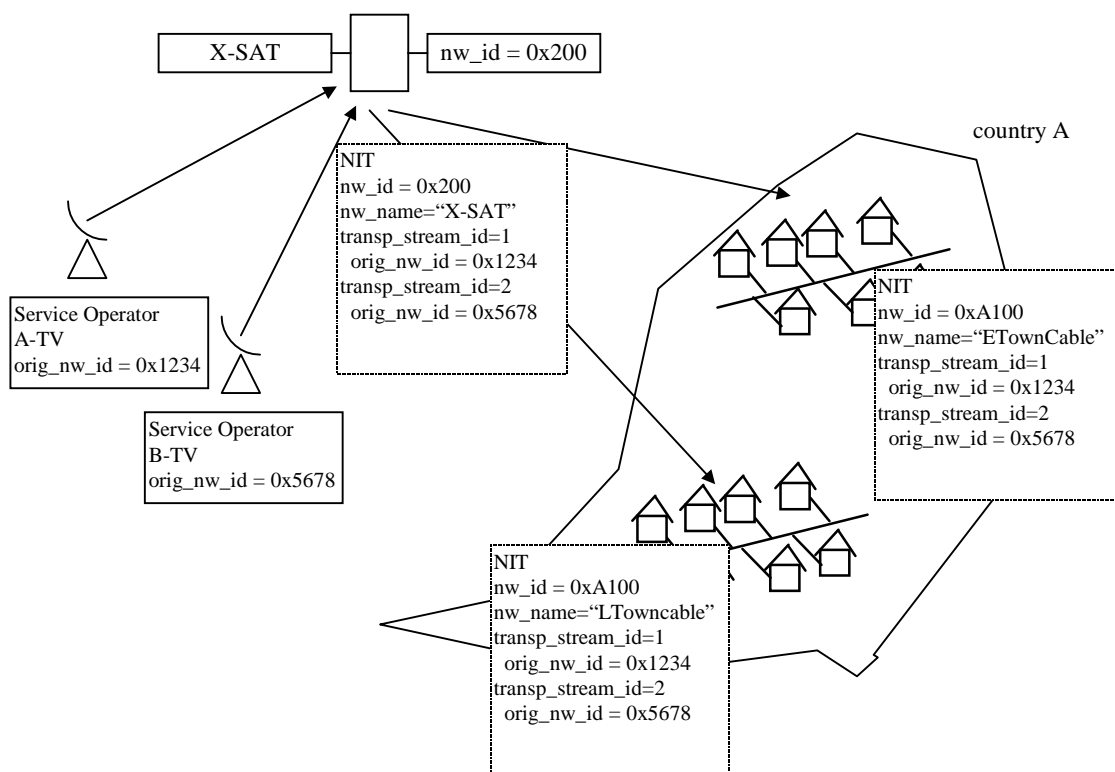

Figure A.2

History

Document history		
Edition 1	October 1995	Publication as ETR 162
V1.2.1	July 2009	Publication
V1.3.1	December 2010	Publication
V1.4.1	May 2011	Publication