

ETSI TS 101 154 V1.11.1 (2012-11)



Technical Specification

**Digital Video Broadcasting (DVB);
Specification for the use of Video and
Audio Coding in Broadcasting Applications
based on the MPEG-2 Transport Stream**

EBU
OPERATING EUROVISION

DVB[®]
Digital Video
Broadcasting

Reference

RTS/JTC-DVB-320

Keywords

broadcasting, digital, DVB, MPEG, TV, video

ETSI

650 Route des Lucioles
F-06921 Sophia Antipolis Cedex - FRANCE

Tel.: +33 4 92 94 42 00 Fax: +33 4 93 65 47 16

Siret N° 348 623 562 00017 - NAF 742 C
Association à but non lucratif enregistrée à la
Sous-Préfecture de Grasse (06) N° 7803/88

Important notice

Individual copies of the present document can be downloaded from:

<http://www.etsi.org>

The present document may be made available in more than one electronic version or in print. In any case of existing or perceived difference in contents between such versions, the reference version is the Portable Document Format (PDF). In case of dispute, the reference shall be the printing on ETSI printers of the PDF version kept on a specific network drive within ETSI Secretariat.

Users of the present document should be aware that the document may be subject to revision or change of status. Information on the current status of this and other ETSI documents is available at

<http://portal.etsi.org/tb/status/status.asp>

If you find errors in the present document, please send your comment to one of the following services:

http://portal.etsi.org/chaicor/ETSI_support.asp

Copyright Notification

No part may be reproduced except as authorized by written permission.
The copyright and the foregoing restriction extend to reproduction in all media.

© European Telecommunications Standards Institute 2012.

© European Broadcasting Union 2012.

All rights reserved.

DECT™, **PLUGTESTS™**, **UMTS™** and the ETSI logo are Trade Marks of ETSI registered for the benefit of its Members.
3GPP™ and **LTE™** are Trade Marks of ETSI registered for the benefit of its Members and of the 3GPP Organizational Partners.

GSM® and the GSM logo are Trade Marks registered and owned by the GSM Association.

Contents

Intellectual Property Rights	12
Foreword.....	12
Introduction	13
1 Scope	16
2 References	16
2.1 Normative references	16
2.2 Informative references.....	18
3 Definitions and abbreviations.....	19
3.1 Definitions.....	19
3.2 Abbreviations	25
4 Systems layer.....	26
4.1 Broadcast bitstreams and Baseline IRDs.....	27
4.1.1 Introduction (ITU-T Recommendation H.222.0 / ISO/IEC 13818-1 Introduction).....	27
4.1.2 Packetized Elementary Stream (PES) (ITU-T Recommendation H.222.0 / ISO/IEC 13818-1 clause Intro.4)	27
4.1.3 Transport stream system target decoder (ITU-T Recommendation H.222.0 / ISO/IEC 13818-1 clause 2.4.2).....	27
4.1.4 Transport packet layer (ITU-T Recommendation H.222.0 / ISO/IEC 13818-1 clause 2.4.3.2).....	28
4.1.4.1 Null packets.....	28
4.1.4.2 Transport packet header	28
4.1.4.2.1 transport_error_indicator	28
4.1.4.2.2 transport_priority	28
4.1.4.2.3 transport_scrambling_control.....	28
4.1.4.2.4 Packet IDentifier (PID) values for Service Information (SI) Tables	28
4.1.5 Adaptation field (ITU-T Recommendation H.222.0 / ISO/IEC 13818-1 clause 2.4.3.4)	28
4.1.5.1 Random_access_indicator.....	28
4.1.5.2 Elementary_stream_priority_indicator.....	29
4.1.5.3 Program Clock Reference (PCR)	30
4.1.5.4 Other fields.....	30
4.1.6 Packetized Elementary Stream (PES) Packet (ITU-T Recommendation H.222.0 / ISO/IEC 13818-1 clause 2.4.3.6).....	31
4.1.6.1 stream_id and stream_type.....	31
4.1.6.2 PES_scrambling_control.....	32
4.1.6.3 PES_priority.....	32
4.1.6.4 Copyright and original_or_copy	32
4.1.6.5 Trick mode fields	32
4.1.6.6 additional_copy_info.....	32
4.1.6.7 Optional fields.....	33
4.1.6.8 PES_extension_field	33
4.1.6.9 Multiple video pictures per PES packet	34
4.1.6.10 Presentation Time Stamp and Decoding Time Stamp occurrence	35
4.1.7 Program Specific Information (PSI) (ITU-T Recommendation H.222.0 / ISO/IEC 13818-1 clause 2.4.4).....	36
4.1.8 Program and elementary stream descriptors (ITU-T Recommendation H.222.0 / ISO/IEC 13818-1 clause 2.6).....	36
4.1.8.1 video_stream_descriptor and audio_stream_descriptor	36
4.1.8.2 hierarchy_descriptor.....	36
4.1.8.3 registration_descriptor.....	37
4.1.8.4 data_stream_alignment_descriptor.....	37
4.1.8.5 target_background_grid_descriptor.....	37
4.1.8.6 video_window_descriptor	37
4.1.8.7 Conditional Access CA_descriptor	37
4.1.8.8 ISO_639_Language_descriptor.....	37

4.1.8.9	system_clock_descriptor	38
4.1.8.10	multiplex_buffer_utilization_descriptor.....	38
4.1.8.11	copyright_descriptor	38
4.1.8.12	maximum_bitrate_descriptor	38
4.1.8.13	private_data_indicator_descriptor	38
4.1.8.14	smoothing_buffer_descriptor	38
4.1.8.15	STD_descriptor	38
4.1.8.16	IBP_descriptor	38
4.1.8.17	MPEG-4_audio_descriptor	38
4.1.8.18	AVC_video_descriptor	39
4.1.8.19	SVC_extension_descriptor.....	39
4.1.8.20	STD audio buffer size	39
4.1.8.21	Use of the DVB-SI component_descriptor and multilingual_component_descriptor.....	40
4.1.8.22	AC-3_descriptor.....	40
4.1.8.23	Enhanced_AC-3_Descriptor	40
4.1.8.24	Void.....	40
4.1.8.24.1	void.....	40
4.1.8.24.2	void.....	40
4.1.8.24.3	void.....	40
4.1.8.25	DTS_descriptor	40
4.1.8.26	AAC_descriptor	41
4.1.8.27	MPEG-4 audio extension descriptor	41
4.1.8.28	MVC_extension_descriptor	41
4.1.8.29	DTS-HD_descriptor	42
4.1.9	Compatibility with ISO/IEC 11172-1 (ITU-T Recommendation H.222.0 / ISO/IEC 13818-1 clause 2.8).....	42
4.1.10	Storage Media Interoperability	42
4.2	Bitstreams from storage applications and IRDs with digital interfaces.....	42
4.2.1	Partial Transport Streams.....	42
4.2.2	Decoding of Trick Play data (ITU-T Recommendation H.222.0 / ISO/IEC 13818-1 clause 2.4.3.7)	42
5	Video	43
5.1	25 Hz MPEG-2 SDTV IRDs and Bitstreams	44
5.1.1	Profile and level	44
5.1.2	Frame rate	44
5.1.3	Aspect ratio	45
5.1.4	Luminance resolution	45
5.1.5	Chromaticity Parameters.....	46
5.1.6	Chrominance.....	47
5.1.7	Video sequence header	47
5.2	25 Hz MPEG-2 HDTV IRDs and Bitstreams.....	47
5.2.1	Profile and level	47
5.2.2	Frame rate	48
5.2.3	Aspect ratio.....	48
5.2.4	Luminance resolution	48
5.2.5	Chromaticity Parameters.....	49
5.2.6	Chrominance.....	49
5.2.7	Video sequence header	49
5.2.8	Backwards Compatibility	50
5.3	30 Hz MPEG-2 SDTV IRDs and Bitstreams	50
5.3.1	Profile and level.....	50
5.3.2	Frame rate.....	50
5.3.3	Aspect ratio.....	50
5.3.4	Luminance resolution	51
5.3.5	Chromaticity Parameters.....	52
5.3.6	Chrominance.....	53
5.3.7	Video sequence header	53
5.4	30 Hz MPEG-2 HDTV IRDs and Bitstreams.....	53
5.4.1	Profile and level.....	53
5.4.2	Frame rate	53
5.4.3	Aspect ratio.....	54
5.4.4	Luminance resolution	54

5.4.5	Chromaticity Parameters.....	55
5.4.6	Chrominance.....	55
5.4.7	Video sequence header.....	55
5.4.8	Backwards Compatibility.....	55
5.5	Specifications Common to all H.264/AVC IRDs and Bitstreams.....	56
5.5.1	General.....	56
5.5.2	Sequence Parameter Set and Picture Parameter Set.....	56
5.5.2.1	pic_width_in_mbs_minus1 and pic_height_in_map_units_minus1.....	56
5.5.3	Video Usability Information.....	57
5.5.3.1	Aspect Ratio Information.....	57
5.5.3.2	Colour Parameter Information.....	57
5.5.3.3	Chrominance Information.....	57
5.5.3.4	Timing Information.....	57
5.5.3.5	Picture Structure Information.....	57
5.5.4	Supplemental Enhancement Information.....	58
5.5.4.1	Picture Timing SEI Message.....	58
5.5.4.2	Pan-Scan Rectangle SEI Message.....	59
5.5.4.3	Still pictures.....	59
5.5.5	Random Access Point.....	59
5.5.5.1	Time Interval Between RAPs.....	60
5.6	H.264/AVC SDTV IRDs and Bitstreams.....	60
5.6.1	Specifications Common to all H.264/AVC SDTV IRDs and Bitstreams.....	60
5.6.1.1	Sequence Parameter Set and Picture Parameter Set.....	60
5.6.1.2	Profile and level.....	61
5.6.1.3	Aspect ratio.....	61
5.6.2	25 Hz H.264/AVC SDTV IRD and Bitstream.....	61
5.6.2.1	Colour Parameter Information.....	61
5.6.2.2	Frame rate.....	62
5.6.2.3	Luminance resolution.....	62
5.6.3	30 Hz H.264/AVC SDTV IRD and Bitstream.....	63
5.6.3.1	Colour Parameter Information.....	63
5.6.3.2	Frame rate.....	63
5.6.3.3	Luminance resolution.....	63
5.7	H.264/AVC HDTV IRDs and Bitstreams.....	64
5.7.1	Specifications common to all H.264/AVC HDTV IRDs and Bitstreams.....	64
5.7.1.1	Sequence Parameter Set and Picture Parameter Set.....	64
5.7.1.2	Aspect ratio.....	65
5.7.1.3	Colour Parameter Information.....	65
5.7.1.4	Luminance resolution.....	65
5.7.2	25 Hz H.264/AVC HDTV IRD and Bitstream.....	66
5.7.2.1	Profile and level.....	66
5.7.2.2	Frame rate.....	66
5.7.2.3	Backwards Compatibility.....	66
5.7.3	30 Hz H.264/AVC HDTV IRD and Bitstream.....	67
5.7.3.1	Profile and level.....	67
5.7.3.2	Frame rate.....	67
5.7.3.3	Backwards Compatibility.....	67
5.7.4	50 Hz H.264/AVC HDTV IRD and Bitstream.....	67
5.7.4.1	Profile and level.....	68
5.7.4.2	Frame rate.....	68
5.7.4.3	Backwards Compatibility.....	68
5.7.5	60 Hz H.264/AVC HDTV IRD and Bitstream.....	68
5.7.5.1	Profile and level.....	68
5.7.5.2	Frame rate.....	68
5.7.5.3	Backwards Compatibility.....	69
5.8	SVC HDTV IRDs and Bitstreams.....	69
5.8.1	Specifications common to all SVC HDTV IRDs and Bitstreams.....	69
5.8.1.1	Classes of SVC operation.....	69
5.8.1.1.1	Class S Bitstream.....	69
5.8.1.1.2	Class Q Bitstream.....	70
5.8.1.1.3	Class M Bitstream.....	70
5.8.1.2	System Considerations.....	71

5.8.1.3	SVC Sequence Parameter Set and Picture Parameter Set	71
5.8.1.3.1	pic_width_in_mbs_minus1 and pic_height_in_map_units_minus1	71
5.8.1.3.2	Subset Sequence Parameter Set	71
5.8.1.4	Video Usability Information	72
5.8.1.4.1	Aspect Ratio Information	72
5.8.1.4.2	Colour Parameter Information	72
5.8.1.4.3	Chrominance Information	73
5.8.1.4.4	Timing Information	73
5.8.1.4.5	Picture Structure Information	74
5.8.1.5	Supplemental Enhancement Information	74
5.8.1.5.1	Picture Timing SEI Message	74
5.8.1.5.2	Pan-Scan Rectangle SEI Message	75
5.8.1.5.3	Scalable Nesting SEI Message	75
5.8.1.5.4	Still pictures	75
5.8.1.6	SVC Random Access Point	75
5.8.1.6.1	Time Interval Between SVC RAPs	76
5.8.2	25 Hz SVC HDTV IRD and Bitstream	77
5.8.2.1	Profile and level	77
5.8.2.2	25 Hz SVC base layer bitstream	77
5.8.2.3	Frame rate	78
5.8.2.4	Luminance resolution	78
5.8.2.5	Aspect Ratio Information	78
5.8.2.6	Backwards Compatibility	79
5.8.3	30 Hz SVC HDTV IRD and Bitstream	79
5.8.3.1	Profile and level	79
5.8.3.2	30 Hz SVC base layer bitstream	80
5.8.3.3	Frame rate	80
5.8.3.4	Luminance resolution	80
5.8.3.5	Aspect Ratio Information	80
5.8.3.6	Backwards Compatibility	81
5.8.4	50 Hz SVC HDTV IRD and Bitstream	81
5.8.4.1	Profile and level	81
5.8.4.2	50 Hz SVC base layer bitstream	82
5.8.4.3	Frame rate	82
5.8.4.4	Luminance resolution	82
5.8.4.5	Aspect Ratio Information	83
5.8.4.6	Backwards Compatibility	83
5.8.5	60 Hz SVC HDTV IRD and Bitstream	83
5.8.5.1	Profile and level	83
5.8.5.2	60 Hz SVC base layer bitstream	84
5.8.5.3	Frame rate	84
5.8.5.4	Luminance resolution	84
5.8.5.5	Aspect Ratio Information	85
5.8.5.6	Backwards Compatibility	85
5.9	25 Hz VC-1 SDTV IRDs and Bitstreams	85
5.9.1	Profile, Level and Colour Difference Format	85
5.9.2	Frame rate	86
5.9.3	Aspect ratio	86
5.9.4	Luminance resolution	86
5.9.5	Colour Parameter Information	87
5.9.6	Random Access Point	87
5.10	25 Hz VC-1 HDTV IRDs and Bitstreams	87
5.10.1	Profile, Level and Colour Difference Format	87
5.10.2	Frame rate	88
5.10.3	Aspect ratio	88
5.10.4	Luminance resolution	88
5.10.5	Colour Parameter Information	88
5.10.6	Random Access Point	89
5.10.7	Backwards Compatibility	89
5.11	30 Hz VC-1 SDTV IRDs and Bitstreams	89
5.11.1	Profile and level	89
5.11.2	Frame rate	89

5.11.3	Aspect ratio	89
5.11.4	Luminance resolution	90
5.11.5	Colour Parameter Information	90
5.11.6	Random Access Point	91
5.12	30 Hz VC-1 HDTV IRDs and Bitstreams	91
5.12.1	Profile, Level and Colour Difference Format	91
5.12.2	Frame rate	91
5.12.3	Aspect ratio	92
5.12.4	Luminance resolution	92
5.12.5	Colour Parameter Information	92
5.12.6	Random Access Point	93
5.12.7	Backwards Compatibility	93
5.13	MVC Stereo HDTV IRDs and Bitstreams	93
5.13.1	Specifications common to all MVC Stereo HDTV IRDs and Bitstreams	93
5.13.1.1	Introduction	93
5.13.1.2	Composition of MVC Stereo HDTV Bitstreams	93
5.13.1.3	MVC Sequence Parameter Set and Picture Parameter Set	94
5.13.1.4	pic_width_in_mbs_minus1 and pic_height_in_map_units_minus1	94
5.13.1.5	Subset Sequence Parameter Set	95
5.13.1.6	Video Usability Information	95
5.13.1.6.1	MVC VUI parameters	95
5.13.1.6.2	Aspect Ratio	95
5.13.1.6.3	Colour Parameter Information	96
5.13.1.6.4	Luminance Resolution	96
5.13.1.7	HRD Conformance	96
5.13.1.8	Supplemental Enhancement Information	97
5.13.1.8.1	Prohibited SEI messages	97
5.13.1.8.2	Order of SEI Messages	98
5.13.1.8.3	Multiview View Position SEI message	98
5.13.1.9	Random Access Point	98
5.13.1.9.1	Time Interval Between RAPs	99
5.13.1.10	Additional constraints	99
5.13.1.10.1	Constraints Common to Base and Dependent Views	99
5.13.1.10.2	MVC Stereo Base view constraints	100
5.13.1.10.2.1	Prohibited NAL units	100
5.13.1.10.3	MVC Stereo Dependent view constraints	100
5.13.1.10.3.1	Prohibited NAL units	100
5.13.1.11	Access Unit Structure	100
5.13.2	25 Hz MVC Stereo HDTV IRD and Bitstream	102
5.13.2.1	Profile and level	102
5.13.2.2	Frame rate	102
5.13.2.3	Backwards Compatibility	102
5.13.3	30 Hz MVC Stereo HDTV IRD and Bitstream	103
5.13.3.1	Profile and level	103
5.13.3.2	Frame rate	103
5.13.3.3	Backwards Compatibility	103
6	Audio	103
6.1	MPEG-1 and MPEG-2 backward compatible audio	104
6.1.1	Audio mode	104
6.1.2	Layer	105
6.1.3	Bitrate	105
6.1.4	Sampling frequency	105
6.1.5	Emphasis	106
6.1.6	Cyclic redundancy code	106
6.1.7	Prediction	106
6.1.8	Multilingual	106
6.1.9	Extension Stream	106
6.1.10	Ancillary Data	106
6.1.11	MPEG Surround configurations, profiles and levels	107
6.2	AC-3 and Enhanced AC-3 audio	107
6.2.1	AC-3 and Enhanced AC-3 PES constraints	107

6.2.1.1	Encoding	107
6.2.1.2	Decoding	108
6.2.1.3	Byte-alignment	108
6.2.2	Enhanced AC-3 with multiple independent substreams - PES constraints	109
6.2.2.1	Encoding	109
6.2.2.2	Decoding	110
6.3	DTS audio	110
6.3.1	DTS and DTS-HD PES Constraints	110
6.3.1.1	Encoding	110
6.3.1.2	Decoding	110
6.3.1.3	Byte-alignment	111
6.4	MPEG-4 AAC, MPEG-4 HE AAC and MPEG-4 HE AAC v2 audio	111
6.4.1	LATM/LOAS formatting	112
6.4.2	Profiles and Levels	113
6.4.2.1	Profiles and Levels for AAC, HE AAC and HE AAC v2	113
6.4.2.2	Profiles and Levels for MPEG Surround in combination AAC, HE AAC and HE AAC v2	114
6.4.3	Dynamic Range Control	114
Annex A (informative):	Examples of Full screen luminance resolutions for SDTV and 25 Hz /30 Hz HDTV	115
Annex B (normative):	Auxiliary Data in the Video Elementary Stream	117
B.1	Overview	117
B.2	Common Syntax and Semantics	117
B.3	Active Format Description (AFD)	118
B.3.1	Coded Frame in MPEG-2 Video	118
B.3.2	Coded Frame in H264/AVC Video	119
B.3.3	Coded Frame in VC-1 Video	119
B.3.4	Common Semantics of AFD	119
B.3.5	Relationship with Pan Vectors	121
B.4	Bar data	121
B.4.1	Recommended Receiver Response to Bar Data	123
B.4.2	Relationship Between Bar Data and AFD	123
B.5	Closed Captions	123
B.5.1	Syntax and Semantics of cc_data()	123
B.6	Auxiliary Data and MPEG-2 video	124
B.6.1	Coding	124
B.6.2	Syntax and Semantics	124
B.7	Auxiliary Data and H264/AVC, MVC Stereo or SVC video	125
B.7.1	Coding	125
B.7.2	Syntax and Semantics	125
B.7.3	Auxiliary Data in MVC Stereo HDTV Bitstreams	125
B.8	Auxiliary Data and VC-1 video	126
B.8.1	Coding	126
B.8.2	Syntax and Semantics	126
B.9	Relationship with Wide Screen Signalling (WSS)	127
B.10	Aspect Ratio Ranges	127
B.11	Multi Region Disparity	127
B.11.1	Syntax and Semantics of Multi Region Disparity	128
Annex C (normative):	Implementation of Ancillary Data for MPEG Audio	133
C.1	Scope	133
C.2	Introduction	133

C.3	DVB Compliance	133
C.4	Detailed specification for MPEG1 and MPEG2	133
C.4.1	DVD-Video Ancillary Data	133
C.4.2	Extended ancillary data syntax	134
C.4.2.1	ancillary_data_sync	135
C.4.2.2	bs_info	135
C.4.2.3	mpeg_audio_type	135
C.4.2.4	dolby_surround_mode	135
C.4.2.5	ancillary_data_bytes	135
C.4.2.6	ancillary_data_status	136
C.4.2.7	advanced_dynamic_range_control	136
C.4.2.8	dialog_normalization	136
C.4.2.8.1	dialog_normalization_on	137
C.4.2.8.2	dialog_normalization_value	137
C.4.2.9	reproduction_level	137
C.4.2.9.1	surround_reproduction_level	137
C.4.2.9.2	production_roomtype	137
C.4.2.9.3	reproduction_level_value	138
C.4.2.10	downmixing_levels_MPEG2	138
C.4.2.10.1	center_mix_level_on	138
C.4.2.10.2	surround_mix_level_on	138
C.4.2.10.3	mix_level_value	138
C.4.2.11	audio_coding_mode	139
C.4.2.11.1	compression_on	139
C.4.2.12	compression_value	139
C.4.2.13	coarse_grain_timecode	139
C.4.2.14	fine_grain_timecode	140
C.4.2.15	scale_factor_CRC	140
C.4.2.16	Announcement Switching Data	140
C.4.2.17	Scale Factor Error Check	141
C.4.2.18	RDS data via UECP protocol	141
C.5	Detailed specification for MPEG4 AAC, HE AAC and HE AAC v2 Audio	142
C.5.1	Transmission of MPEG4 Audio ancillary data	142
C.5.2	MPEG4 Audio ancillary data syntax	143
C.5.2.1	ancillary_data_sync	143
C.5.2.2	bs_info	143
C.5.2.2.1	mpeg_audio_type	144
C.5.2.2.2	dolby_surround_mode	144
C.5.2.2.3	drc_presentation_mode	144
C.5.2.3	ancillary_data_status	145
C.5.2.4	downmixing_levels_MPEG4	145
C.5.2.4.1	center_mix_level_on	145
C.5.2.4.2	surround_mix_level_on	146
C.5.2.4.3	mix_level_value	146
C.5.2.5	audio_coding_mode	147
C.5.2.5.1	compression_on	147
C.5.2.5.2	compression_value	147
C.5.2.6	coarse_grain_timecode	147
C.5.2.7	fine_grain_timecode	147
C.5.2.8	Persistence of MPEG4 ancillary data	147
C.5.3	Announcement Switching Data	148
C.5.4	DRC Presentation Mode	148
Annex D (normative):	Coding of Data Fields in the Private Data Bytes of the Adaptation Field.....	152
D.1	Introduction	152
D.2	Private data bytes detailed specification	152
D.2.1	Announcement Switching Data	153
D.2.2	AU_information	153

D.3	PVR assistance	157
D.3.1	Introduction (informative)	157
D.3.2	Encoding of PVR assist information (normative)	158
D.3.3	Tier framework	158
D.3.3.1	Background (informative)	159
D.3.3.2	Specification (normative)	159
D.3.3.3	Examples of tier number assignment (informative)	160
D.3.4	Sub-stream framework	161
D.3.4.1	Background (informative)	161
D.3.4.2	Tier Signalling (normative)	161
D.3.4.3	Playback speed information (normative)	162
D.3.4.4	Sub-stream associated with a Playback speed (normative)	162
D.3.4.5	Examples of sub-streams (informative)	162
D.3.5	Segmentation signalling	163
D.3.6	PVR Assistance Signalling Syntax	164
Annex E (normative): Supplementary Audio Services		168
E.1	Overview	168
E.2	Syntax and semantics	169
E.3	Coding for Audio Description SA services	170
E.4	Coding for Clean Audio SA services	172
E.5	Decoder behaviour	172
E.6	Decoder user indicators	173
Annex F (informative): Encoding Guidelines to Enable Trick Play Support of H.264/AVC Streams		174
F.1	Introduction	174
F.1.1	Overview	174
F.1.2	Technical Requirements	174
F.2	Discardable Pictures	175
F.2.1	MPEG-2 Discardable Pictures	175
F.2.2	H.264/AVC Discardable Pictures	176
F.2.3	Discardable Pictures and Trick Play Speeds	176
F.2.4	Smooth Trick Play and Compression Efficiency	177
F.2.5	Impact of Adaptive Encoding on Guidelines	178
Annex G (informative): Random Access Point Considerations for SVC		179
G.1	Scope	179
G.2	Overview	179
G.3	Encoder Implementation Guidelines	179
G.4	Decoder Implementation Guidelines	180
G.4.1	Decoding process with output picture skipping	180
G.4.2	Decoding process with seamless output	182
G.4.3	Display Process at a Transition from Base to Enhancement Layer Decoding	183
Annex H (normative): Frame Compatible Plano-Stereoscopic 3DTV		185
H.1	Scope	185
H.2	Frame compatible plano-stereoscopic 3DTV definition	185
H.3	System layer specifications common to all plano-stereoscopic 3DTV IRDs and Bitstreams	186
H.3.1	General	186
H.3.2	Frame compatible plano-stereoscopic 3DTV Specific Program Elementary Stream descriptor	186
H.3.2.1	AVC_video_descriptor	186

H.4	Video specifications Common to all frame compatible plano-stereoscopic 3DTV IRDs and Bitstreams	186
H.4.1	General	186
H.4.2	Supplemental Enhancement Information	187
H.4.2.1	Frame Packing Arrangement SEI Message	187
Annex I (normative):	Considerations for Encoding and Random Access for MVC Stereo Video	190
I.1	Video Sequence Structure	190
I.1.1	Closed Coded Video Sequence	191
I.1.2	Open Coded Video Sequence	191
I.2	Guidelines for TS Packet Multiplexing	192
Annex J (informative):	Bibliography	194
	History	195

Intellectual Property Rights

IPRs essential or potentially essential to the present document may have been declared to ETSI. The information pertaining to these essential IPRs, if any, is publicly available for **ETSI members and non-members**, and can be found in ETSI SR 000 314: "*Intellectual Property Rights (IPRs); Essential, or potentially Essential, IPRs notified to ETSI in respect of ETSI standards*", which is available from the ETSI Secretariat. Latest updates are available on the ETSI Web server (<http://ipr.etsi.org>).

Pursuant to the ETSI IPR Policy, no investigation, including IPR searches, has been carried out by ETSI. No guarantee can be given as to the existence of other IPRs not referenced in ETSI SR 000 314 (or the updates on the ETSI Web server) which are, or may be, or may become, essential to the present document.

Foreword

This Technical Specification (TS) has been produced by Joint Technical Committee (JTC) Broadcast of the European Broadcasting Union (EBU), Comité Européen de Normalisation ELECTrotechnique (CENELEC) and the European Telecommunications Standards Institute (ETSI).

The original TS 101 154 [i.1] was based on the DVB document A001 and it covered only the 25 Hz SDTV Baseline IRD. The first revision of TS 101 154 [i.1] extended the scope to encompass both the 25 Hz SDTV Baseline IRD and the 25 Hz SDTV IRD with a digital interface intended for connection to a bitstream storage device such as a digital VCR. The second revision covered both the Baseline IRD and the IRD with digital interface for 25 Hz SDTV, 25 Hz HDTV, 30 Hz SDTV and 30 Hz HDTV. Subsequent revisions added optional support for H.264/AVC for video content and optional support of HE AAC and HE AACv2 for audio content, the video Active Format Description (annex B), AC-3 audio and Enhanced AC-3 audio, Ancillary Data for MPEG audio (annex C), the Coding of Data Fields in the Private Data Bytes of the Adaptation Field (annex D), optional support for DTS audio and receiver-mixed audio), optional support of VC-1 for video content, optional support of Closed Captions, Bar Data and RDS, optional support for MPEG Surround, supplementary audio, optional support for Clean Audio (annex E) optional support for H.264/AVC High Profile at Level 4.2 for video content, and optional support for SVC for video content, optional support for Extended-gamut YCC colour space for video applications (xvYCC) and optional support for Frame Compatible Plano-Stereoscopic 3DTV (annex H). This revision adds optional support for DTS-HD, optional support for MVC Stereo Full Resolution HD 3DTV, optional support for multi region disparity (annex B.11) and gives guidelines for the transmission of MVC Stereo video over broadcast networks (annex I).

The revisions to the TS have been developed in a largely backwards compatible manner, i.e. no changes to the mandatory functionality of a previously defined IRD have been made between one edition of the TS and the next.

The present document is complementary to TS 102 154 [i.2], which provides Implementation Guidelines for the use of Video and Audio Coding in Contribution and Primary Distribution Applications based on the MPEG-2 Transport Stream.

The present document is complementary to TS 102 005 [i.3], which provides the specification for the use of Video and Audio Coding in DVB services delivered directly over IP protocols.

NOTE: The EBU/ETSI JTC Broadcast was established in 1990 to co-ordinate the drafting of standards in the specific field of broadcasting and related fields. Since 1995 the JTC Broadcast became a tripartite body by including in the Memorandum of Understanding also CENELEC, which is responsible for the standardization of radio and television receivers. The EBU is a professional association of broadcasting organizations whose work includes the co-ordination of its members' activities in the technical, legal, programme-making and programme-exchange domains. The EBU has active members in about 60 countries in the European broadcasting area; its headquarters is in Geneva.

European Broadcasting Union
CH-1218 GRAND SACONNEX (Geneva)
Switzerland
Tel: +41 22 717 21 11
Fax: +41 22 717 24 81

The Digital Video Broadcasting Project (DVB) is an industry-led consortium of broadcasters, manufacturers, network operators, software developers, regulatory bodies, content owners and others committed to designing global standards for the delivery of digital television and data services. DVB fosters market driven solutions that meet the needs and economic circumstances of broadcast industry stakeholders and consumers. DVB standards cover all aspects of digital television from transmission through interfacing, conditional access and interactivity for digital video, audio and data. The consortium came together in 1993 to provide global standardisation, interoperability and future proof specifications.

Introduction

The present document presents guidelines covering coding and decoding using the MPEG-2 system layer, video coding and audio coding.

The guidelines presented in the present document for the Integrated Receiver-Decoder (IRD) are intended to represent a minimum functionality that all IRDs of a particular class are required to either meet or exceed. It is necessary to specify the minimum IRD functionality for basic parameters, if broadcasters are not to be prevented from ever using certain features. For example, if a significant population of IRDs were produced that supported only the Simple Profile, broadcasters would never be able to transmit Main Profile bitstreams.

IRDs are classified in five dimensions as:

- "25 Hz" ("50 Hz") or "30 Hz" ("60 Hz"), depending on whether the nominal video frame rates based on 25 Hz or 30 000/1 001 Hz (approximately 29,97 Hz) are supported. It is expected that 25 Hz IRDs and 50 Hz IRDs will be used in those countries where the existing analogue TV transmissions use 25 Hz frame rate and 30 Hz IRDs and 60 Hz IRDs will be used in countries where the analogue TV transmissions use 30 000/1 001 Hz frame rate. There are also likely to be "dual-standard" IRDs which have the capabilities of both 25 Hz (50 Hz) and 30 Hz (60 Hz) IRDs.
- "SDTV" or "HDTV", depending on whether or not they are limited to decoding pictures of conventional TV resolution. The capabilities of an SDTV IRD are a sub-set of those of an HDTV IRD.
- "with digital interface" or "Baseline", depending on whether or not they are intended for use with a digital bitstream storage device such as a digital VCR. The capabilities of a Baseline IRD are a sub-set of those of an IRD with digital interface.
- MPEG-2 video, H.264/AVC, SVC or VC-1 video coding formats.
- Audio coding formats according to clause 6.

To give a complete definition of an IRD, all five dimensions need to be specified, e.g.:

- 25 Hz SDTV Baseline IRD MPEG-2 video, MPEG-1 Layer II audio, for an IRD able to decode 720 × 576 interlaced 25 Hz video pictures.
- 30 Hz HDTV Baseline IRD H264/AVC video, HE AAC Level 4 audio, for an IRD able to decode up to 1 920 × 1 080 interlaced 30 Hz video pictures or 1 280 × 720 progressive 60 Hz video pictures.

All the formats supported by an IRD conforming to the present document are listed in annex A.

It should be noted that in DVB systems the source picture format, encoded picture format and display picture format do not need to be identical. For example, HDTV source material may be broadcast as an SDTV bitstream after down-conversion to SDTV resolution and encoding within the constraints of MPEG-2 video Main Profile at Main Level. The IRD receiving the bitstream may then up-convert the decoded picture for display at HDTV resolution.

Another notable feature of the DVB system is that a single Transport Stream may contain programme material intended for more than one type of IRD. A typical example of this is likely to be the simulcasting of SDTV and HDTV video material. In this case an SDTV IRD will decode and display SDTV pictures whilst an HDTV IRD will decode and display HDTV pictures from the same Transport Stream.

Where a feature described in the present document is mandatory, the word "shall" is used and the text is in *italics*; all other features are optional. The functionality is specified in the form of constraints on MPEG-2 systems, video and audio formats which the IRDs are required to decode correctly.

The specification of these baseline features in no way prohibits IRD manufacturers from including additional features, and should not be interpreted as stipulating any form of upper limit to the performance. The guidelines do not cover features, such as the IRDs up-sampling filter, which affect the quality of the displayed picture rather than whether the IRD is able to decode pictures at all. Such issues are left to the marketplace.

The guidelines presented for IRDs observe the following principles:

- wherever practical, IRDs should be designed to allow for future compatible extensions to the bitstream syntax;
- all "reserved" and "private" bits in MPEG-2 systems, video and audio formats should be ignored by IRDs not designed to make use of them.

The rules of operation for the encoders are features and constraints which the encoding system should adhere to in order to ensure that the transmissions can be correctly decoded. These constraints may be mandatory or optional. Where a feature or constraint is mandatory, the word "shall" is used and the text is italic; all other features are optional.

Clauses 4 to 6 and the annexes, provide the guidelines for the Digital Video Broadcasting (DVB) systems layer, video and audio respectively. For information, some of the key features are summarized below, but clauses 4 to 6 and the annexes should be consulted for all definitions:

Systems:

- MPEG-2 Transport Stream (TS) is used.
- Service Information (SI) is based on MPEG-2 program-specific information.
- Scrambling is as defined in TS 101 289 [i.15].
- Conditional access uses the MPEG-2 Conditional Access CA_descriptor.
- Partial Transport Streams are used for digital VCR applications.

Video:

- MPEG-2 Main Profile at Main Level is used for MPEG-2 encoded SDTV.
- MPEG-2 Main Profile at High Level is used for MPEG-2 encoded HDTV.
- H.264/AVC Main Profile at Level 3 is used for H.264/AVC SDTV.
- H.264/AVC High Profile at Level 4 is used for 25 Hz and 30 Hz H.264/AVC HDTV.
- H.264/AVC High Profile at Level 4.2 is used for 50 Hz and 60 Hz H.264/AVC HDTV.
- H.264/AVC Scalable High Profile at Level 4 is used for 25 Hz and 30 Hz SVC HDTV.
- H.264/AVC Stereo High Profile at Level 4 is used for 25 Hz and 30 Hz MVC Stereo HDTV.
- H.264/AVC Scalable High Profile at Level 4.2 is used for 50 Hz and 60 Hz SVC HDTV.
- VC-1 Advanced Profile at Level 1 is used for VC-1 SDTV.
- VC-1 Advanced Profile at Level 3 is used for VC-1 HDTV.
- The 25 Hz MPEG-2 SDTV IRD, 25 Hz H.264/AVC SDTV IRD and 25 Hz VC-1 SDTV IRD support 25 Hz frame rate.
- The 25 Hz MPEG-2 HDTV IRD, 25 Hz H.264/AVC HDTV IRD and 25 Hz VC-1 HDTV IRD support frame rates of 25 Hz or 50 Hz.
- The 30 Hz MPEG-2 SDTV IRD, 30 Hz H.264/AVC SDTV IRD and 30 Hz VC-1 SDTV IRD support frame rates of 24 000/1 001, 24, 30 000/1 001 and 30 Hz;
- The 30 Hz MPEG-2 HDTV IRD, 30 Hz H.264/AVC HDTV IRD and 30 Hz VC-1 HDTV IRD supports frame rates of 24 000/1 001, 24, 30 000/1 001, 30, 60 000/1 001 and 60 Hz.

- SDTV pictures may have either 4:3, 16:9 or 2.21:1 aspect ratio; IRDs support 4:3 and 16:9 and optionally 2.21:1 aspect ratio.
- MPEG-2 HDTV pictures have 16:9 or 2.21:1 aspect ratio; IRDs support 16:9 and optionally 2.21:1 aspect ratio.
- H.264/AVC HDTV pictures have 16:9 aspect ratio; IRDs support 16:9 aspect ratio.
- SVC HDTV pictures have 16:9 aspect ratio; IRDs support 16:9 aspect ratio.
- MVC Stereo HDTV pictures have 16:9 aspect ratio; IRDs support 16:9 aspect ratio.
- VC-1 HDTV pictures have 16:9 aspect ratio; IRDs support 16:9 aspect ratio.
- MPEG-2 IRDs support the use of pan vectors to allow a 4:3 monitor to give a full-screen display of a 16:9 coded picture of SDTV resolution.
- IRDs may also optionally support the use of the Active Format Description (refer to annex B of the present document) as part of the logic to control the processing and positioning of the reconstructed image for display.
- IRDs may also optionally support frame compatible plano-stereoscopic 3DTV services (see annex H).

Audio:

- Audio content complies with MPEG-1 Layer I, MPEG-1 Layer II, MPEG-2 Layer II backward compatible, AC-3, Enhanced AC-3, DTS, DTS-HD, MPEG-4 AAC, MPEG-4 HE AAC or MPEG-4 HE AAC v2 audio. MPEG-1 Layer II, MPEG-4 AAC, MPEG-4 HE AAC and MPEG-4 HE AAC v2 audio streams may optionally include MPEG Surround data.
- Sampling rates of 32 kHz, 44,1 kHz and 48 kHz are supported by IRDs.
- The encoded bitstream does not use emphasis.
- IRDs may also optionally support full multi-channel decoding of MPEG-2 Layer II backwards compatible multi-channel audio.
- The use of Layer II encoding is recommended for MPEG-1 audio bitstreams.
- IRDs may also optionally support the decoding of MPEG audio streams which include ancillary data (see annex C).
- IRDs may also optionally support supplementary-mixed services (see annex E).

1 Scope

The present document provides implementation guidelines for the use of audio-visual coding in satellite, cable and terrestrial broadcasting distribution systems that utilize MPEG-2 Systems. Standard Definition Television (SDTV), High Definition Television (HDTV), Frame Compatible Plano-Stereoscopic 3DTV and Full Resolution HD 3DTV using MVC Stereo are covered. MPEG-2, H.264/AVC, SVC, MVC Stereo and VC-1 video coding systems are covered. MPEG-1 Layer I, MPEG-1 Layer II, MPEG-2 Layer II backward compatible, Dolby AC-3, Enhanced AC-3, DTS, DTS-HD, MPEG-4 HE AAC and MPEG-4 HE AAC v2 audio coding systems are covered. Furthermore, the combination of MPEG-1 Layer II with MPEG Surround and the combination of MPEG-4 AAC or MPEG-4 HE AAC or MPEG-4 HE AAC v2 with MPEG Surround are covered. Guidelines for devices equipped with a digital interface intended for digital VCR applications are also given in the present document. It does not cover applications such as contribution services which are likely to be the subject of subsequent "Guidelines" documents.

The rules of operation for the encoders are features and constraints which the encoding system should adhere to in order to ensure that the transmissions can be correctly decoded. These constraints may be mandatory, recommended or optional.

2 References

References are either specific (identified by date of publication and/or edition number or version number) or non-specific. For specific references, only the cited version applies. For non-specific references, the latest version of the reference document (including any amendments) applies.

Referenced documents which are not found to be publicly available in the expected location might be found at <http://docbox.etsi.org/Reference>.

NOTE: While any hyperlinks included in this clause were valid at the time of publication ETSI cannot guarantee their long term validity.

2.1 Normative references

The following referenced documents are necessary for the application of the present document.

- [1] ITU-T Recommendation H.222.0 / ISO/IEC 13818-1: "Information Technology - Generic Coding of moving pictures and associated audio information: Systems".

NOTE: Please refer whenever possible to the latest version and subsequent amendments.

- [2] ITU-T Recommendation H.262 / ISO/IEC 13818-2: "Information technology - Generic coding of moving pictures and associated audio information: Video".
- [3] ISO/IEC 13818-3: "Information technology -- Generic coding of moving pictures and associated audio information -- Part 3: Audio".
- [4] ISO/IEC 13818-9: "Information technology -- Generic coding of moving pictures and associated audio information -- Part 9: Extension for real time interface for systems decoders".
- [5] Void.
- [6] ETSI EN 300 468: "Digital Video Broadcasting (DVB); Specification for Service Information (SI) in DVB systems".
- [7] ETSI TS 101 211 (V1.10.1): "Digital Video Broadcasting (DVB); Guidelines on implementation and usage of Service Information (SI)".
- [8] ISO/IEC 11172-1: "Information technology -- Coding of moving pictures and associated audio for digital storage media up to about 1,5 Mbit/s -- Part 1: Systems".
- [9] ISO/IEC 11172-3: "Information technology -- Coding of moving pictures and associated audio for digital storage media at up to about 1,5 Mbit/s -- Part 3: Audio".

- [10] ITU-T Recommendation J.17: "Pre-emphasis used on sound-programme circuits".
- [11] EBU Recommendation R.68: "Alignment level in digital audio production equipment and in digital audio recorders".
- [12] ETSI TS 102 366: "Digital Audio Compression (AC-3, Enhanced AC-3) Standard".
- [13] ITU-R Recommendation BT.709: "Parameter values for the HDTV standards for production and international programme exchange".
- [14] ETSI EN 300 294: "Television systems; 625-line television Wide Screen Signalling (WSS)".
- [15] ETSI TS 102 114 (V1.4.1): "DTS Coherent Acoustics; Core and Extensions with Additional Profiles".
- [16] ITU-T Recommendation H.264 / ISO/IEC 14496-10:2012: "Information technology - Coding of audio-visual objects- Part 10: Advanced Video Coding" and ISO/IEC 14496-10:2012/Amd 1: "Additional profiles and supplemental enhancement information (SEI) messages".
- [17] ISO/IEC 14496-3:2009: "Information technology -- Coding of audio-visual objects -- Part 3: Audio".
- [18] ETSI EN 300 401: "Radio Broadcasting Systems; Digital Audio Broadcasting (DAB) to mobile, portable and fixed receivers".
- [19] ITU-T Recommendation T.35: "Procedure for the allocation of ITU-T defined codes for non-standard facilities".
- [20] SMPTE ST 421:2006: "Television - VC-1 Compressed Video Bitstream Format and Decoding Process".
- [21] SMPTE RP 227:2010: "VC-1 Bitstream Transport Encodings".
- [22] RDS-Forum SPB 490: "RDS Universal Encoder Communication Protocol", Final Version 6.02, September 2006.
- [23] SMPTE ST 2016-1:2009: "Format for Active Format Description and Bar Data".
- [24] CEA-CEB16: "Active Format Description (AFD) & Bar Data Recommended Practice".
- [25] ITU-R Recommendation BT.1700: "Characteristics of composite video signals for conventional analogue television systems".
- [26] CEA-708-C: "Digital Television (DTV) Closed Captioning" Consumer Electronics Association.
- [27] ISO 639: "Codes for the representation of names of languages".
- [28] ISO/IEC 13818-1:2007/Amd.1:2007: "Transport of MPEG-4 streaming text and MPEG-4 lossless audio over MPEG-2 systems".
- [29] ISO/IEC 23003-1:2007: "Information technology -- MPEG audio technologies -- Part 1: MPEG Surround".
- [30] ISO/IEC 23003-1:2007/Cor 1:2008: "MPEG audio technologies -- Part 1: MPEG Surround, Technical corrigendum 1".
- [31] IEC 61966-2-4: "Multimedia systems and equipment - Colour measurement and management - Part 2-4: Colour management - Extended-gamut YCC colour space for video applications - xvYCC".
- [32] ETSI TS 101 547-1: "Digital Video Broadcasting (DVB); Plano-Stereoscopic 3DTV".
- [33] ETSI TS 101 547-2: "Digital Video Broadcasting (DVB); Frame Compatible Plano-Stereoscopic 3DTV".
- [34] ETSI TS 101 547-3: "Digital Video Broadcasting (DVB); HDTV Service Compatible Plano-Stereoscopic 3DTV".

2.2 Informative references

The following referenced documents are not necessary for the application of the present document but they assist the user with regard to a particular subject area.

- [i.1] ETSI TR 101 154 (V1.4.1): "Digital Video Broadcasting (DVB); Implementation guidelines for the use of MPEG-2 Systems, Video and Audio in satellite, cable and terrestrial broadcasting applications".
- [i.2] ETSI TS 102 154: "Digital Video Broadcasting (DVB); Implementation guidelines for the use of Video and Audio Coding in Contribution and Primary Distribution Applications based on the MPEG-2 Transport Stream".
- [i.3] ETSI TS 102 005: "Digital Video Broadcasting (DVB); Specification for the use of Video and Audio Coding in DVB services delivered directly over IP protocols".
- [i.4] ITU-R Recommendation BT.470: "Conventional Television Systems".

NOTE: The present document only references Systems B, G, and I.

- [i.5] ITU-R Recommendation BT.1358 (1998): "Studio parameters of 625 and 525 line progressive scan television systems".
- [i.6] Void.
- [i.7] Void.
- [i.8] SMPST ST 125:1995: "Television - Component Video Signal 4:2:2 - Bit-Parallel Digital Interface".
- [i.9] SMPTE ST 170:2004: "Television - Composite Analog Video Signal - NTSC for Studio Applications".
- [i.10] SMPTE ST 267:1995: "Television - Bit-Parallel Digital Interface - Component Video Signal 4:2:2 16x9 Aspect Ratio".
- [i.11] SMPTE ST 274:2008: "Television - 1920 x 1080 Image Sample Structure, Digital Representation and Digital Timing Reference Sequences for Multiple Picture Rates".
- [i.12] SMPTE ST 293:2003: "Television - 720 x 483 Active Line at 59.94-Hz Progressive Scan Production - Digital Representation".
- [i.13] SMPTE ST 296:2012: "Television - 1280 x 720 Progressive Image Sample Structure - Analog and Digital Representation and Analog Interface (R2006)".
- [i.14] HDMI LLC, High-Definition Multimedia Interface Specification Version 1.4a. March 4, 2010.

NOTE: Available at: <http://www.hdmi.org/manufacturers/specification.aspx>.

- [i.15] ETSI TS 101 289 (V1.1.1): "Digital Video Broadcasting (DVB); Support for use of scrambling and Conditional Access (CA) within digital broadcasting systems".
- [i.16] Blu-ray Disc Association: 'White Paper Blu-ray Disc™ Read-Only Format 2.B Audio Visual Application Format Specifications for BD-ROM Version 2.5', July 2011.

NOTE: Available at: http://blu-raydisc.com/assets/Downloadablefile/BD-ROM-AV-WhitePaper_110712.pdf

- [i.17] ITU-R Recommendation BS.1770-2 "Algorithms to measure audio programme loudness and true-peak audio level.

3 Definitions and abbreviations

3.1 Definitions

For the purposes of the present document, the following terms and definitions apply:

25 Hz H.264/AVC HDTV Bitstream: bitstream which contains only H.264/AVC High Profile at Level 4 (or simpler) video at 25 Hz or 50 Hz frame rates as specified in the present document

25 Hz H.264/AVC HDTV IRD: IRD that is capable of decoding and displaying pictures based on a nominal video frame rate of 25 Hz or 50 Hz from H.264/AVC High Profile at Level 4 bitstreams as specified in the present document, in addition to providing the functionality of a 25 Hz H.264/AVC SDTV IRD

25 Hz H.264/AVC SDTV Bitstream: bitstream which contains only H.264/AVC Main Profile at Level 3 video at 25 Hz frame rate as specified in the present document

25 Hz H.264/AVC SDTV IRD: IRD which is capable of decoding and displaying pictures based on a nominal video frame rate of 25 Hz from H.264/AVC Main Profile at Level 3 bitstreams as specified in the present document

25 Hz MPEG-2 HDTV Bitstream: bitstream which contains only MPEG-2 Main Profile, High Level (or simpler) video at 25 Hz or 50 Hz frame rates as specified in the present document

25 Hz MPEG-2 HDTV IRD: IRD that is capable of decoding and displaying pictures based on a nominal video frame rate of 25 Hz or 50 Hz from MPEG-2 Main Profile, High Level bitstreams as specified in the present document, in addition to providing the functionality of a 25 Hz SDTV IRD

25 Hz MPEG-2 SDTV Bitstream: bitstream which contains only MPEG-2 Main Profile, Main Level video at 25 Hz frame rate as specified in the present document

25 Hz MPEG-2 SDTV IRD: IRD which is capable of decoding and displaying pictures based on a nominal video frame rate of 25 Hz from MPEG-2 Main Profile, Main Level bitstreams as specified in the present document

25 Hz MVC Stereo HDTV Bitstream: MVC bitstream that contains a 25 Hz MVC Stereo Base view bitstream and a 25 Hz MVC Stereo Dependent view bitstream as specified in the present document. A 25 Hz MVC Stereo Bitstream contains only H.264/AVC Stereo High Profile at Level 4 video at 25 or 50 Hz frame rates as specified in the present document

25 Hz MVC Stereo HDTV IRD: IRD that is capable of decoding and displaying pictures based on nominal video frame rates of 25 or 50 Hz from H.264/AVC Stereo High Profile Level 4 bitstreams as specified in the present document, in addition to providing the functionality of a 25 Hz H.264/AVC HDTV IRD

25 Hz SVC HDTV Bitstream: SVC bitstream that contains a 25 Hz SVC HDTV Bitstream Subset as specified in the present document

25 Hz SVC HDTV Bitstream Subset: bitstream subset, of an SVC Bitstream, that contains coded slice NAL units with DQId greater than 0 and contains only H.264/AVC Scalable High Profile at Level 4 (or simpler) video at 25 Hz or 50 Hz frame rates as specified in the present document

25 Hz SVC HDTV IRD: IRD that is capable of decoding and displaying pictures based on nominal video frame rate of 25 Hz or 50 Hz from H.264/AVC Scalable High Profile Level 4 bitstreams as specified in the present document, in addition to providing the functionality of a 25 Hz H.264/AVC HDTV IRD

25 Hz VC-1 HDTV Bitstream: bitstream which contains only VC-1 Advanced Profile at Level 3 (or simpler) video at 25 Hz or 50 Hz frame rates as specified in the present document

25 Hz VC-1 HDTV IRD: IRD that is capable of decoding and displaying pictures based on a nominal video frame rate of 25 Hz or 50 Hz from VC-1 Advanced Profile at Level 3 bitstreams as specified in the present document, in addition to providing the functionality of a 25 Hz VC-1 SDTV IRD

25 Hz VC-1 SDTV Bitstream: bitstream which contains only VC-1 Advanced Profile at Level 1 video at 25 Hz frame rate as specified in the present document

25 Hz VC-1 SDTV IRD: IRD which is capable of decoding and displaying pictures based on a nominal video frame rate of 25 Hz from VC-1 Advanced Profile at Level 1 bitstreams as specified in the present document

30 Hz H.264/AVC HDTV Bitstream: bitstream which contains only H.264/AVC High Profile at Level 4 (or simpler) video at 24 000/1 001, 24, 30 000/1 001, 30, 60 000/1 001 or 60 Hz frame rates as specified in the present document

30 Hz H.264/AVC HDTV IRD: IRD that is capable of decoding and displaying pictures based on nominal video frame rates of 24 000/1 001, 24, 30 000/1 001, 30, 60 000/1 001 or 60 Hz from H.264/AVC High Profile at Level 4 bitstreams as specified in the present document, in addition to providing the functionality of a 30 Hz H.264/AVC SDTV IRD

30 Hz H.264/AVC SDTV Bitstream: bitstream which contains only H.264/AVC Main Profile at Level 3 video at 24 000/1 001, 24, 30 000/1 001 or 30 Hz frame rate as specified in the present document

30 Hz H.264/AVC SDTV IRD: IRD which is capable of decoding and displaying pictures based on a nominal video frame rate of 24 000/1 001 (approximately 23,98), 24, 30 000/1 001 (approximately 29,97) or 30 Hz from H.264/AVC Main Profile at Level 3 bitstreams as specified in the present document

30 Hz MPEG-2 HDTV Bitstream: bitstream which contains only MPEG-2 Main Profile, High Level (or simpler) video at 24 000/1 001, 24, 30 000/1 001, 30, 60 000/1 001 or 60 Hz frame rates as specified in the present document

30 Hz MPEG-2 HDTV IRD: IRD that is capable of decoding and displaying pictures based on nominal video frame rates of 24 000/1 001, 24, 30 000/1 001, 30, 60 000/1 001 or 60 Hz from MPEG-2 Main Profile, High Level bitstreams as specified in the present document, in addition to providing the functionality of a 30 Hz SDTV IRD

30 Hz MPEG-2 SDTV Bitstream: bitstream which contains only MPEG-2 Main Profile, Main Level video at 24 000/1 001, 24, 30 000/1 001 or 30 Hz frame rate as specified in the present document

30 Hz MPEG-2 SDTV IRD: IRD which is capable of decoding and displaying pictures based on a nominal video frame rate of 24 000/1 001 (approximately 23,98), 24, 30 000/1 001 (approximately 29,97) or 30 Hz from MPEG-2 Main Profile at Main Level bitstreams as specified in the present document

30 Hz MVC Stereo HDTV Bitstream: MVC bitstream that contains a 30 Hz MVC Stereo Base view bitstream and a 30 Hz MVC Stereo Dependent view bitstream as specified in the present document. A 30 Hz MVC Stereo HDTV Bitstream contains only H.264/AVC Stereo High Profile at Level 4 video at 24 000/1001, 24, 30 000/1 001, 30, 60 000/1 001 or 60 Hz frame rates as specified in the present document

30 Hz MVC Stereo HDTV IRD: IRD that is capable of decoding and displaying pictures based on nominal video frame rates of 24 000/1001, 24, 30 000/1 001, 30, 60 000/1 001 or 60 Hz from H.264/AVC Stereo High Profile Level 4 bitstreams as specified in the present document, in addition to providing the functionality of a 30 Hz H.264/AVC HDTV IRD

30 Hz SVC HDTV Bitstream: SVC bitstream that contains a 30 Hz SVC HDTV Bitstream Subset as specified in the present document

30 Hz SVC HDTV Bitstream Subset: bitstream subset, of an SVC Bitstream, that contains coded slice NAL units with DQId greater than 0 and contains only H.264/AVC Scalable High Profile at Level 4 (or simpler) video at 24 000/1 001, 24, 30 000/1 001, 30, 60 000/1 001 or 60 Hz frame rates as specified in the present document

30 Hz SVC HDTV IRD: IRD that is capable of decoding and displaying pictures based on nominal video frame rates of 24 000/1 001, 24, 30 000/1 001, 30, 60 000/1 001 or 60 Hz from H.264/AVC Scalable High Profile Level 4 bitstreams as specified in the present document, in addition to providing the functionality of a 30 Hz H.264/AVC HDTV IRD

30 Hz VC-1 HDTV Bitstream: bitstream which contains only VC-1 Advanced Profile at Level 3 (or simpler) video at 24 000/1 001, 24, 30 000/1 001, 30, 60 000/1 001 or 60 Hz frame rates as specified in the present document

30 Hz VC-1 HDTV IRD: IRD that is capable of decoding and displaying pictures based on nominal video frame rates of 24 000/1 001, 24, 30 000/1 001, 30, 60 000/1 001 or 60 Hz from VC-1 Advanced Profile at Level 3 bitstreams as specified in the present document, in addition to providing the functionality of a 30 Hz SDTV IRD

30 Hz VC-1 SDTV Bitstream: bitstream which contains only VC-1 Advanced Profile at Level 1 video at 24 000/1 001, 24, 30 000/1 001 or 30 Hz frame rate as specified in the present document

30 Hz VC-1 SDTV IRD: IRD which is capable of decoding and displaying pictures based on a nominal video frame rate of 24 000/1 001 (approximately 23,98), 24, 30 000/1 001 (approximately 29,97) or 30 Hz from VC-1 Advanced Profile at Level 1 bitstreams as specified in the present document

3DTV: DVB frame compatible plano-stereoscopic three-dimensional television

50 Hz H.264/AVC HDTV Bitstream: bitstream which contains only H.264/AVC High Profile at Level 4.2 (or simpler) video at 25 Hz or 50 Hz frame rates as specified in the present document

50 Hz H.264/AVC HDTV IRD: IRD that is capable of decoding and displaying pictures based on a nominal video frame rate of 25 Hz or 50 Hz from H.264/AVC High Profile at Level 4.2 bitstreams as specified in the present document, in addition to providing the functionality of a 25 Hz H.264/AVC HDTV IRD

50 Hz SVC HDTV Bitstream: SVC bitstream that contains a 50 Hz SVC HDTV Bitstream Subset as specified in the present document

50 Hz SVC HDTV Bitstream Subset: bitstream subset, of an SVC Bitstream, that contains coded slice NAL units with DQId greater than 0 and contains only H.264/AVC Scalable High Profile at Level 4.2 (or simpler) video at 25 Hz or 50 Hz frame rates as specified in the present document

50 Hz SVC HDTV IRD: IRD that is capable of decoding and displaying pictures based on a nominal video frame rate of 25 Hz or 50 Hz from H.264/AVC High Profile at Level 4.2 bitstreams as specified in the present document, in addition to providing the functionality of a 50 Hz H.264/AVC HDTV IRD and a 25 Hz SVC HDTV IRD

60 Hz H.264/AVC HDTV Bitstream: bitstream which contains only H.264/AVC High Profile at Level 4.2 (or simpler) video at 24 000/1 001, 24, 30 000/1 001, 30, 60 000/1 001 or 60 Hz frame rates as specified in the present document

60 Hz H.264/AVC HDTV IRD: IRD that is capable of decoding and displaying pictures based on nominal video frame rates of 24 000/1 001, 24, 30 000/1 001, 30, 60 000/1 001 or 60 Hz from H.264/AVC High Profile at Level 4.2 bitstreams as specified in the present document, in addition to providing the functionality of a 30 Hz H.264/AVC HDTV IRD

60 Hz SVC HDTV Bitstream: SVC bitstream that contains a 60 Hz SVC HDTV Bitstream Subset as specified in the present document

60 Hz SVC HDTV Bitstream Subset: bitstream subset, of an SVC Bitstream, that contains coded slice NAL units with DQId greater than 0 and contains only H.264/AVC Scalable High Profile at Level 4.2 (or simpler) video at 24 000/1 001, 24, 30 000/1 001, 30, 60 000/1 001 or 60 Hz frame rates as specified in the present document

60 Hz SVC HDTV IRD: IRD that is capable of decoding and displaying pictures based on nominal video frame rates of 24 000/1 001, 24, 30 000/1 001, 30, 60 000/1 001 or 60 Hz from H.264/AVC Scalable High Profile Level 4.2 bitstreams as specified in the present document, in addition to providing the functionality of a 60 Hz H.264/AVC HDTV IRD and a 30 Hz SVC HDTV IRD

AVC video sub-bitstream of MVC: video sub-bitstream that contains only the base view, i.e containing all VCL NAL units associated with the minimum value of view order index present in each AVC video sequence of the AVC video stream. The AVC video sub-bitstream shall conform to the specification of a H.264/AVC HDTV Bitstream

AVC video sub-bitstream of SVC: video sub-bitstream that contains the base layer as defined in annex G of ITU-T Recommendation H.264 / ISO/IEC 14496-10 [16] and that additionally contains NAL units with nal_unit_type equal to 14 (prefix NAL units)

NOTE: The AVC video sub-bitstream contains all VCL NAL units associated with dependency_id equal to 0.

Baseline IRD: IRD which provides the minimum functionality to decode transmitted bitstreams as recommended in the present document

NOTE: It is not required to have the ability to decode Partial Transport Streams as may be received from a digital interface connected to digital bitstream storage device such as a digital VCR.

Frame Compatible: arrangement of the Left and Right images in a spatial multiplex which results in an image which can be treated like a normal HDTV image by the receiver demodulator and compression decoder

H.264/AVC Bitstream: collective term referring to the H.264/AVC SDTV Bitstream and the H.264/AVC HDTV Bitstream

H.264/AVC GOP: collection of H.264/AVC Access Units (AUs) starting at, and including the AU comprising the H.264/AVC RAP, and including all the AUs up to, but not including the next AU that is an H.264/AVC RAP

H.264/AVC HDTV Bitstream: collective term referring to the 25 Hz H.264/AVC HDTV Bitstream, the 30 Hz H.264/AVC HDTV Bitstream, the 50 Hz H.264/AVC HDTV Bitstream and the 60 Hz H.264/AVC HDTV Bitstream

H.264/AVC HDTV IRD: collective term referring to the 25 Hz H.264/AVC HDTV IRD, the 30 Hz H.264/AVC HDTV IRD, the 50 Hz H.264/AVC HDTV IRD and the 60 Hz H.264/AVC HDTV IRD

H.264/AVC IRD: collective term referring to the H.264/AVC SDTV IRD and the H.264/AVC HDTV IRD

H.264/AVC SDTV Bitstream: collective term referring to the 25 Hz H.264/AVC SDTV Bitstream and the 30 Hz H.264/AVC SDTV Bitstream

H.264/AVC SDTV IRD: collective term referring to the 25 Hz H.264/AVC SDTV IRD and the 30 Hz H.264/AVC SDTV IRD

H.264/AVC RAP: access unit with AU delimiter in an H.264/AVC Bitstream at which an IRD can begin decoding video successfully

NOTE: This access unit includes exactly one Sequence Parameter Set (that is active) with VUI and the Picture Parameter Set that is required for decoding the associated picture. The SPS also precedes any SEI NAL units in this access unit. This access unit contains an IDR picture or an I picture.

I picture: picture (frame or field) containing only intra macroblocks

IRD with Digital Interface: IRD which has the ability to decode Partial Transport Streams received from a digital interface connected to digital bitstream storage device such as a digital VCR as specified in the present document, in addition to providing the functionality of a Baseline IRD

MPEG-2 Bitstream: collective term referring to the 25 Hz MPEG-2 SDTV Bitstream, 30 Hz MPEG-2 SDTV Bitstream, 25 Hz MPEG-2 HDTV Bitstream, 30 Hz MPEG-2 HDTV Bitstream

MPEG-2 IRD: collective term referring to the 25 Hz MPEG-2 SDTV IRD, 30 Hz MPEG-2 SDTV IRD, 25 Hz MPEG-2 HDTV IRD, 30 Hz MPEG-2 HDTV IRD

MVC Stereo anchor picture: the MVC Stereo equivalent to an H.264/AVC RAP. An MVC Stereo anchor picture is composed of exactly one base view component and exactly one dependent view component

MVC Stereo access unit: A set of NAL units that are consecutive in decoding order and contain exactly one primary coded picture consisting of one base view component and one dependent view component. In addition to the primary coded picture, an MVC Stereo access unit may also contain one or more redundant coded pictures, one auxiliary coded picture, or other NAL units not containing slices or slice data partitions of a coded picture. The decoding of an MVC Stereo access unit always results in one decoded picture consisting of one or two decoded view components. Clause 5.13 gives further details about the composition of the base view and dependent view components

MVC Stereo Base view component: A coded representation of the Base view in a single access unit

MVC Stereo Base view (or Dependent view) bitstream: a collection of all VCL NAL units and associated non-VCL NAL units associated with the value of view_id corresponding to the Base view (or the Dependent view), of a video bitstream conforming to the H.264/AVC Stereo High Profile Level 4, as defined in ITU-T Recommendation H.264 / ISO/IEC 14496-10 [16]

NOTE: The MVC Stereo Base view bitstream is the MVC Stereo equivalent to the AVC video sub-bitstream of MVC as per ITU-T Recommendation H.222.0 / ISO/IEC 13818-1 [28] (with the additional restrictions specified in clause) and under the H.264/AVC Stereo High Profile Level 4 constraints. The MVC Stereo Dependent view bitstream is equivalent to the MVC video sub-bitstream in ITU-T Recommendation H.222.0 / ISO/IEC 13818-1 [1] under the H.264/AVC Stereo High Profile Level 4 constraints.

MVC Stereo Bitstream: bitstream that conforms to the H.264/AVC Stereo High Profile Level 4 specified in Annex H of ITU-T Recommendation H.264 / ISO/IEC 14496-10 [16], and with the restrictions specified in the present document

MVC Stereo Corresponding (or associated) view component: Opposite (Base/Dependent) view component with same value of Presentation Timestamp (PTS)

MVC Stereo coded video sequence: collection of MVC Stereo access units (AUs) starting at, and including the AU comprising the MVC Stereo RAP, and including all the AUs up to, but not including the next AU that is an MVC Stereo RAP

MVC Stereo Dependent view component: A coded representation of Dependent view in a single access unit

MVC Stereo Dependent unit: A set of NAL units that are consecutive in decoding order and contain exactly one non-Base view component. A dependent unit starts from a view and dependency representation delimiter NAL unit, `VDRD_nal_unit` (`nal_unit_type = 24`)

MVC Stereo HDTV Bitstream: collective term referring to the 25 Hz MVC Stereo HDTV Bitstream, and the 30 Hz MVC Stereo HDTV Bitstream

MVC Stereo HDTV IRD: collective term referring to the 25 Hz MVC Stereo HDTV IRD, and the 30 Hz MVC Stereo HDTV IRD

MVC Stereo HDTV sub-bitstream: collective term referring to either the MVC Stereo Base view bitstream or the MVC Stereo Dependent view bitstreams of 25 Hz MVC Stereo HDTV or 30 Hz MVC Stereo HDTV Bitstreams

Pan Vector: horizontal offset in video frame centre position specified by non zero value in the `frame_centre_horizontal_offset` field in the MPEG video stream

Partial Transport Stream: bitstream derived from an MPEG-2 Transport Stream by removing those Transport Stream Packets that are not relevant to one particular selected programme, or a number of selected programmes

Plano-stereoscopic: three-dimensional picture that uses two single pictures, Left and Right, displayed on a single plane surface (the TV screen in the case of 3DTV)

SVC access unit: access unit as specified in annex G of ITU-T Recommendation H.264 / ISO/IEC 14496-10 [16]

NOTE: An SVC access unit results from re-assembling SVC dependency representations as specified in ITU-T Recommendation H.222.0 / ISO/IEC 13818-1 [1].

SVC base layer bitstream: bitstream subset of an SVC Bitstream that conforms to one or more H.264/AVC profiles specified in annex A of ITU-T Recommendation H.264 / ISO/IEC 14496-10 [16]

NOTE: The SVC base layer bitstream of an SVC bitstream is specified in subclause G.8.8.2 of ITU-T Recommendation H.264 / ISO/IEC 14496-10 [16].

SVC base layer RAP: set of all NAL units that are present in the AVC video sub-bitstream of an SVC Access unit

NOTE: The SVC Base layer RAP obeys the constraints of the corresponding H.264/AVC RAP. Additionally the subset SPS of all enhancement layers follow the SPS of the SVC base layer RAP and are ordered with increasing value of DQId.

SVC Bitstream: bitstream that conforms to one or more of the profiles specified in annex G of ITU-T Recommendation H.264 / ISO/IEC 14496-10 [16]

SVC dependency representation: collection of all VCL NAL units with the same value of `dependency_id` of an SVC access unit and the associated non-VCL NAL units

NOTE: Re-assembling SVC dependency representations in a consecutive order of `dependency_id` starting from the lowest value of `dependency_id` present in the access unit up to any value of `dependency_id` present in the access unit, while reordering the non-VCL NAL units conforming to the order of NAL units within an access unit as specified in annex G of ITU-T Recommendation H.264 / ISO/IEC 14496-10 [16], results in an SVC access unit.

SVC enhancement layer RAP: set of all NAL units that are present in the SVC video sub-bitstream of an SVC Access unit

NOTE: The subset SPS of all enhancement layers with `dependency_id` greater than the `dependency_id` of the SVC Enhancement layer RAP follow the subset SPS of this SVC Enhancement layer RAP and are ordered with increasing value of DQId.

SVC HDTV Bitstream Subset: collective term referring to the 25 Hz SVC HDTV Bitstream Subset, the 30 Hz SVC HDTV Bitstream Subset, the 50 Hz SVC HDTV Bitstream Subset, and the 60 Hz SVC HDTV Bitstream Subset

SVC HDTV Bitstream: collective term referring to the 25 Hz SVC HDTV Bitstream, the 30 Hz SVC HDTV Bitstream, the 50 Hz SVC HDTV Bitstream, and the 60 Hz SVC HDTV Bitstream

SVC HDTV IRD: collective term referring to the 25 Hz SVC HDTV IRD, the 30 Hz SVC HDTV IRD, the 50 Hz SVC HDTV IRD, and the 60 Hz SVC HDTV IRD

SVC I picture: picture (frame or field) containing one or more SVC dependency representations that only consist of slices with slice_type equal to 2 or 7

NOTE: An SVC I picture is associated with one or more values of dependency_id. An SVC I picture for a particular value of dependency_id specifies that the SVC dependency representation with the particular value of dependency_id only consists of slices with slice_type equal to 2 or 7.

SVC IRD: alternative term referring to SVC HDTV IRD

SVC IDR picture: picture (frame or field) containing one or more SVC dependency representations that have idr_flag equal to 1

NOTE: An SVC IDR picture is associated with one or more values of dependency_id. An SVC IDR picture for a particular value of dependency_id specifies that the SVC dependency representation with the particular value of dependency_id has idr_flag equal to 1. Each SVC IDR picture for a particular value of dependency_id is an SVC I picture for the particular value of dependency_id.

SVC layer picture: picture obtained from decoding a subset or the complete set of the SVC dependency representations present in an SVC access unit

NOTE: An SVC layer picture is associated with a particular value of dependency_id. An SVC layer picture for a particular value of dependency_id is the picture obtained by decoding all SVC dependency representations of an SVC access unit with dependency_id less than or equal to the particular value of dependency_id.

SVC layer representation: collection of all VCL NAL units with the same value of quality_id of an SVC dependency representation

SVC random access dependency representation (SVC RADP): SVC dependency representation of an SVC RAP for which dependency_id is equal to one of the values that are associated with the SVC RAP

SVC RAP: collective term for an SVC Base layer RAP or an SVC Enhancement layer RAP

NOTE: An SVC RAP for a particular value of dependency_id specifies that an IRD can begin decoding the SVC layer pictures for the particular value of dependency_id. An SVC RAP includes all SVC Sequence Parameter Sets including VUI and all Picture Parameter Sets that are referenced in the VCL NAL units of the access unit. The access unit does not contain any Sequence Parameter Set (nal_unit_type equal to 7) that is not referenced in the VCL NAL units of the access unit. Any SVC Sequence Parameter Set precedes any SEI NAL units in this access unit. An SVC RAP contains an SVC I picture (which may be an SVC IDR picture). An SVC RAP has temporal_id equal to 0.

SVC video sub-bitstream: video sub-bitstream that contains VCL NAL units with nal_unit_type equal to 20 with the same NAL unit header syntax element dependency_id not equal to 0

VC-1 access point: access unit in a VC-1 Bitstream at which an IRD can begin decoding video successfully

NOTE: This access unit contains a sequence header and can have no decoding dependence on any data preceding this point.

VC-1 Bitstream: collective term referring to the VC-1 SDTV Bitstream and the VC-1 HDTV Bitstream

VC-1 HDTV Bitstream: collective term referring to the 25 Hz VC-1 HDTV Bitstream and the 30 Hz VC-1 HDTV Bitstream

VC-1 HDTV IRD: collective term referring to the 25 Hz VC-1 HDTV IRD and the 30 Hz VC-1 HDTV IRD

VC-1 IRD: collective term referring to the VC-1 SDTV IRD and the VC-1 HDTV IRD

VC-1 SDTV Bitstream: collective term referring to the 25 Hz VC-1 SDTV Bitstream and the 30 Hz VC-1 SDTV Bitstream

VC-1 SDTV IRD: collective term referring to the 25 Hz VC-1 SDTV IRD and the 30 Hz VC-1 SDTV IRD

Video sub-bitstream: collection of all VCL NAL units associated with the same value of dependency_id of a video bitstream conforming to annex G of ITU-T Recommendation H.264 / ISO/IEC 14496-10 [16] and all associated non-VCL NAL units in decoding order as defined in ITU-T Recommendation H.264 / ISO/IEC 14496-10 [16]

NOTE: Re-assembling video sub-bitstreams in a consecutive order of dependency_id, starting from the dependency_id equal to 0 up to any value of dependency_id, results in a video bitstream conforming to annex G of ITU-T Recommendation H.264 / ISO/IEC 14496-10 [16].

3.2 Abbreviations

For the purposes of the present document, the following abbreviations apply:

AAC Advanced Audio Coding

NOTE: According to ISO/IEC 14496-3 [17].

AC-3 Dolby AC-3 audio coding system

NOTE: According to TS 102 366 [12].

AD Audio Description
 AFD Active Format Description
 AOT Audio Object Type
 AU Access Unit
 AVC Advanced Video Coding
 CA Conditional Access
 CEA Consumer Electronics Association
 CPB Coded Picture Buffer
 DAB Digital Audio Broadcasting
 DAR Display Aspect Ratio
 DRC Dynamic Range Control

NOTE: As defined in ISO/IEC 14496-3 [17].

DTH Direct-To-Home
 DTS DTS audio coding system
 DTS-HD Advanced DTS audio coding system

NOTE: According to TS 102 114 [15].

DVB Digital Video Broadcasting
 DVD Digital Versatile Disc
 ES Elementary Stream
 ESCR Elementary Stream Clock Reference
 FC Frame Compatible
 H.264/AVC Advanced Video Coding for Generic Audiovisual Services

NOTE: According to H.264/AVC [16].

HDMI High-Definition Multimedia Interface
 HDTV High Definition Television
 HE AAC High-Efficiency Advanced Audio Coding

NOTE: According to ISO/IEC 14496-3 [17].

HRD Hypothetical Reference Decoder
 IDR Instantaneous Decoding Refresh

NOTE: As defined in H.264/AVC [16].

I-frame Intra-coded frame
 IRD Integrated Receiver-Decoder

LATM Low overhead Audio Transport Multiplex
 LKFS Loudness, K weighted, relative to nominal full scale

NOTE: According to ITU-R Recommendation BS.1770-2 [i.17].

LOAS Low Overhead Audio Stream
 MPEG Moving Pictures Experts Group
 MVC Multi-View Coding
 NIT Network Information Table
 PAT Program Association Table
 PCR Program Clock Reference
 PES Packetized Elementary Stream
 PID Packet IDentifier
 PMT Program Map Table
 POC Picture Order Count
 PPS Picture Parameter Set

NOTE: As defined in H.264/AVC [16].

PS Parametric Stereo
 PSI Program Specific Information
 PTS Presentation TimeStamp
 RAP Random Access Point
 RDS Radio Data System
 SBR Spectral Band Replication
 ScF-CRC Scale Factor Cyclic Redundancy Check
 SDTV Standard Definition Television
 SEI Supplemental Enhancement Information
 SI Service Information
 SPS Sequence Parameter Set

NOTE: As defined in H.264/AVC [16].

STD System Target Decoder
 SVC Scalable Video Coding

NOTE: As specified in annex G of H.264/AVC [16].

TS Transport Stream
 TSMT Transport Stream Description Table
 T-STD Transport stream-System Target Decoder
 UECP Universal Encoder Communication Protocol
 VC-1 advanced Video Coding

NOTE: According to SMPTE ST 421 [20].

VCR Video Cassette Recorder
 VUI Video Usability Information
 WSS Wide Screen Signalling

4 Systems layer

This clause describes the guidelines for encoding the systems layer of MPEG-2 in DVB broadcast bitstreams, and for decoding this layer in the IRD. The source bitstream may be transmitted via a satellite, cable or terrestrial channel, or via a digital interface. Clause 4.1 applies to the encoding of all source bitstreams and their decoding by a Baseline IRD. Clause 4.2 gives specific information relating to bitstreams transmitted via a digital interface intended for VCR applications and decoding by IRDs equipped with such an interface.

4.1 Broadcast bitstreams and Baseline IRDs

The multiplexing of baseband signals and associated data conforms to ITU-T Recommendation H.222.0 / ISO/IEC 13818-1 [1]. Some of the parameters and fields are not used in the DVB System and these restrictions are described below.

To allow full compliance to ITU-T Recommendation H.222.0 / ISO/IEC 13818-1 [1] and upward compatibility with future enhanced versions, a DVB IRD shall be able to skip over data structures which are currently "reserved", or which correspond to functions not implemented by the IRD. As an example of this capability, a descriptor tag not yet defined within the DVB System shall be interpreted as a no-action tag, its length field correctly decoded and subsequent data skipped.

For the same reason, IRD design should be made under the assumption that any legal structure as permitted by ITU-T Recommendation H.222.0 / ISO/IEC 13818-1 [1] may occur in the broadcast stream even if presently reserved or unused. Therefore the following is assumed:

- *private data shall only be acted upon by decoders which are so enabled;*
- *filling out the bitstream shall be carried out using the normal stuffing mechanism. Reserved fields shall not be used for this purpose. Data of reserved fields shall be set to 0xFF.*

The headings in this clause are based on ITU-T Recommendation H.222.0 / ISO/IEC 13818-1 [1]. The numbers in brackets after the headings are the relevant chapter and clause headings of ITU-T Recommendation H.222.0 / ISO/IEC 13818-1 [28].

4.1.1 Introduction (ITU-T Recommendation H.222.0 / ISO/IEC 13818-1 Introduction)

MPEG-2 systems specify two types of multiplexed data stream: the transport stream and the program stream.

Encoding: *The transmitted multiplex shall use the transport stream.*

Decoding: *All Baseline IRDs shall be able to demultiplex the MPEG-2 transport stream. Demultiplexing of program streams (as described in clauses Intro.2 and Intro.3 of ITU-T Recommendation H.222.0 / ISO/IEC 13818-1 [1]) is optional.*

4.1.2 Packetized Elementary Stream (PES) (ITU-T Recommendation H.222.0 / ISO/IEC 13818-1 clause Intro.4)

Encoding: *The creation of a physical Packetized Elementary Stream (PES) by an encoder is not required. ESCR fields and ES rate fields need not be coded.*

Decoding: *ESCR fields and ES rate fields need not be decoded.*

4.1.3 Transport stream system target decoder (ITU-T Recommendation H.222.0 / ISO/IEC 13818-1 clause 2.4.2)

Encoding: *The system clock frequency shall conform to the tolerance specified in clause 2.4.2.1 of ITU-T Recommendation H.222.0 / ISO/IEC 13818-1 [1]. It is recommended that the tolerance is within 5 parts per million.*

Decoding: *The IRD shall operate over the full tolerance range of the system clock frequency specified in clause 2.4.2.1 of ITU-T Recommendation H.222.0 / ISO/IEC 13818-1 [1].*

4.1.4 Transport packet layer (ITU-T Recommendation H.222.0 / ISO/IEC 13818-1 clause 2.4.3.2)

4.1.4.1 Null packets

Encoding: *The encoding of null packets (those with PID value 0x1FFF) shall be as specified in ITU-T Recommendation H.222.0 / ISO/IEC 13818-1 [1].*

4.1.4.2 Transport packet header

4.1.4.2.1 Transport_error_indicator

Encoding: It is recommended that any error detecting devices in a transmission path should set the **transport_error_indicator** bit when uncorrectable errors are detected.

Decoding: Whenever the **transport_error_indicator** flag is set in the transmitted stream it is recommended that the IRD should then invoke a suitable concealment or error recovery mechanism.

4.1.4.2.2 Transport_priority

Decoding: The **transport_priority** bit has no meaning to the IRD, and may be ignored.

4.1.4.2.3 Transport_scrambling_control

Encoding: *The transport_scrambling_control bits shall be set according to table 1, in accordance with TS 101 289 [i.15].*

Table 1: Coding of transport_scrambling_control bits

Value	Description
00	no scrambling of TS packet payload
01	reserved for future DVB use
10	TS packet scrambled with Even key
11	TS packet scrambled with Odd key

Decoding: *These bits shall be read by the IRD, and the IRD shall respond in accordance with table 1.*

4.1.4.2.4 Packet Identifier (PID) values for Service Information (SI) Tables

Encoding: The assignment of PID values for SI data is given in EN 300 468 [6].

4.1.5 Adaptation field (ITU-T Recommendation H.222.0 / ISO/IEC 13818-1 clause 2.4.3.4)

4.1.5.1 Random_access_indicator

For MPEG-2 Video Bitstreams, the following applies:

Encoding: It is recommended that the **random_access_indicator** bit is set whenever a random access point occurs in video streams (i.e. video sequence header immediately followed by an I-frame).

For H.264/AVC Bitstreams, the following applies:

Encoding: *The **random_access_indicator** bit shall be set whenever an H.264/AVC RAP occurs in video streams (see H.264/AVC RAP definition in clauses 3.1 and 5.5.5).*

Decoding: The **random_access_indicator** bit may be ignored by the IRD. It can be beneficially utilized together with the **elementary_stream_priority** indicator to identify RAP.

For SVC Bitstreams, the following applies:

- Encoding: *The **random_access_indicator** bit shall be set whenever an SVC random access dependency representation (as part of an SVC RAP) occurs in video sub-bitstreams (see SVC random access dependency representation definition in clauses 3.1 and SVC RAP definition in clauses 3.1 and 5.8.1.6).*
- Decoding: *The **random_access_indicator** bit may be ignored by the IRD. It can be beneficially utilized together with the **elementary_stream_priority** indicator to identify SVC random access dependency representations and SVC RAPs.*

For VC-1 Bitstreams, the following applies:

- Encoding: *The **random_access_indicator** bit shall be set whenever a VC-1 Access Point occurs in video streams (see **random_access_indicator** and VC-1 Access Point definitions in SMPTE RP 227 [21]).*
- Decoding: *The **random_access_indicator** bit may be ignored by the IRD. It can be beneficially utilized together with the **elementary_stream_priority** indicator to identify a VC-1 Access Point.*

For MVC Bitstreams, the following applies:

- Encoding: *The **random_access_indicator** bit shall be set whenever an MVC Stereo random access view component (as part of an MVC Stereo RAP) occurs in the MVC Bitstream (see MVC Stereo RAP definition in clause 3.1). Both Base and Dependent view components of an MVC Stereo RAP shall set this bit to "1".*
- Decoding: *The **random_access_indicator** bit may be ignored by the IRD. It can be beneficially utilized together with the **elementary_stream_priority** indicator to identify MVC Stereo random access view components in Base and Dependent views.*

4.1.5.2 Elementary_stream_priority_indicator

For MPEG-2 Video Bitstreams, the following applies:

- Decoding: *The **elementary_stream_priority_indicator** bit may be ignored by the IRD.*

For H.264/AVC Bitstreams, the following applies:

- Encoding: *The **elementary_stream_priority_indicator** bit shall be set only when an access unit containing an I or IDR picture (all slices of the picture have a slice_type equal to 0x02 or 0x07) is present in H264/AVC video streams.*

*The **elementary_stream_priority_indicator** shall be set in the adaptation header of the transport packet that contains the first slice start code of this I or IDR picture (per ISO/IEC 13818-1 [1]). This adaptation header may be in the transport packet immediately after the packet containing the **random_access_indicator**.*

- Decoding: *The **elementary_stream_priority_indicator** bit may be ignored by the IRD. It can be beneficially utilized to support trick modes.*

For SVC Bitstreams, the following applies:

- Encoding: *The **elementary_stream_priority_indicator** bit shall be set only when an SVC dependency representation that consists only of slices with slice_type equal to 0x02 or 0x07 is present in an video sub-bitstream.*

*The **elementary_stream_priority_indicator** shall be set in the adaptation header of the transport packet that contains the first slice start code of this SVC dependency representation (per ITU-T Recommendation H.222.0 / ISO/IEC 13818-1 [1]). This adaptation header may be in the transport packet immediately after the packet containing the **random_access_indicator**.*

- Decoding: *The **elementary_stream_priority_indicator** bit may be ignored by the IRD. It can be beneficially utilized to support trick modes.*

For VC-1 Bitstreams, the following applies:

- Encoding: *The **elementary_stream_priority_indicator** bit shall be set only when an access unit containing an I picture is present in VC-1 video streams (see **elementary_stream_priority_indicator** definition in SMPTE RP 227 [21]).*
- Decoding: The **elementary_stream_priority_indicator** bit may be ignored by the IRD. It can be beneficially utilized to support trick modes.

For MVC Bitstreams, the following applies:

- Encoding: *The **elementary_stream_priority_indicator** bit shall be set only when an I or an IDR picture (slice_type 0x02 or 0x07) is present in the MVC Base view or in the MVC Dependent view of an MVC Stereo access unit. If an I or an IDR picture is present in both base and dependent views of the same access unit, then this bit shall be set to "1" for both view components.*

*The **elementary_stream_priority_indicator** shall be set in the adaptation header of the transport packet that contains the first slice start code of this I or IDR picture (per ISO/IEC 13818-1 [1]). This adaptation header may be in the transport packet immediately after the packet containing the **random_access_indicator**.*

- Decoding: The **elementary_stream_priority_indicator** bit may be ignored by the IRD. It can be beneficially utilized to support trick modes.

4.1.5.3 Program Clock Reference (PCR)

- Encoding: *The time interval between two consecutive PCR values of the same program shall not exceed 100 ms as specified in clause 2.7.2 of ITU-T Recommendation H.222.0 / ISO/IEC 13818-1 [1].*

For MVC Stereo Bitstreams, the PCR shall not be placed in the MVC Stereo Dependent bitstream, because legacy receivers might be unable to decode the (2D HDTV) MVC Stereo Base view bitstream.

- Decoding: *The IRD shall operate correctly with PCRs for a program arriving at intervals not exceeding 100 ms.*

4.1.5.4 Other fields

This clause covers the following fields:

- original_program_clock_reference_base;
- original_program_clock_reference_extension;
- splice_countdown;
- private_data_byte;
- adaptation_field_extension (including fields within).

- Encoding: These fields are optional in a DVB bitstream. *The flags that indicate the presence or absence of each of these fields shall be set appropriately.*

NOTE: *The usage of private_data_byte should comply with annex D of the present document.*

- Decoding: *IRDs shall be able to accept bitstreams which contain these fields. IRDs may ignore the data within the fields.*

4.1.6 Packetized Elementary Stream (PES) Packet (ITU-T Recommendation H.222.0 / ISO/IEC 13818-1 clause 2.4.3.6)

4.1.6.1 stream_id and stream_type

Encoding: *Elementary streams shall be identified by stream_id and stream_type in accordance with ITU-T Recommendation H.222.0 / ISO/IEC 13818-1 [1], tables 2-22 and 2-34.*

For VC-1 Bitstreams, the following applies:

Encoding: *Elementary streams shall be identified by **stream_id** (with the extension mechanism) and **stream_type** in accordance with SMPTE RP 227 [21].*

*For VC-1 Bitstreams, the value of **stream_type** shall be set to 0xEA.*

Decoding: *IRDs shall be able to accept bitstreams which contain these encoded values.*

For MPEG-4 AAC, MPEG-4 HE AAC and MPEG-4 HE AAC v2 audio streams, the following applies:

Encoding: *The value of the **stream_id** field for LATM/LOAS formatted MPEG-4 AAC, MPEG-4 HE AAC and MPEG-4 HE AAC v2 packetized elementary streams shall be 110x xxxx, where each x can be either 0, or 1. The value of **stream_type** for MPEG-4 AAC, MPEG-4 HE AAC and MPEG-4 HE AAC v2 packetized elementary streams shall be 0x11 (indicating ISO/IEC 14496-3 [17] Audio with the LATM transport syntax).*

Decoding: *This field shall be read by the IRD, and the IRD shall interpret this field in accordance with MPEG systems syntax.*

For AC-3, Enhanced AC-3, DTS or DTS-HD audio streams, the following applies:

Encoding: *AC-3, Enhanced AC-3, DTS and DTS-HD packetized elementary streams shall conform to the requirements of a user private stream type 1, as described in ITU-T Recommendation H.222.0 / ISO/IEC 13818-1 [1]. The value of the **stream_id** field for an AC-3, Enhanced AC-3, DTS or DTS-HD elementary stream shall be 0xBD (indicating private_stream_1). The recommended value of **stream_type** for an AC-3, Enhanced AC-3, DTS or DTS-HD elementary stream shall be 0x06 (indicating PES packets containing private data). Multiple AC-3, Enhanced AC-3, DTS or DTS-HD streams may share the same value of **stream_id** since each stream is carried with a unique PID value. The mapping of values of PID to **stream_type** is indicated in the transport stream Program Map Table (PMT).*

Decoding: *These fields shall be read by the IRD, and the IRD shall interpret these fields in accordance with MPEG systems syntax.*

For MVC bitstreams, the following applies:

Encoding: *Elementary streams shall be identified by stream_id and stream_type in accordance with ITU-T Recommendation H.222.0 / ISO/IEC 13818-1 [1], tables 2-22 and 2-34. In case of an AVC video sub-bitstream of MVC, as defined in 2.1.88 and 2.1.85 of H.222.0 / ISO/IEC 13818-1 [1] and following the constraints in clause 3.1 of this document, the stream_type for this elementary stream shall be equal to 0x1B. The MVC video sub-bitstream containing the Dependent View shall have the stream_type value equal to 0x20.*

The value of stream_id for both Base and Dependent view bitstreams shall be equal to 1110 0000 (binary) as per ITU-T Recommendation H.222.0 ISO/IEC 13818-1 [1].

Decoding: *IRDs shall be able to accept bitstreams which contain these encoded values.*

4.1.6.2 PES_scrambling_control

Encoding: *The PES_scrambling_control bits shall be set according to table 2, in accordance with TS 101 289 [i.15].*

Table 2: Coding of PES_scrambling_control bits

Value	Description
00	no scrambling of PES packet payload
01	reserved for future DVB use
10	PES packet scrambled with Even key
11	PES packet scrambled with Odd key

Decoding: *The PES_scrambling_control bits shall be read by the IRD, and the IRD shall respond in accordance with table 2.*

4.1.6.3 PES_priority

Decoding: The **PES_priority** bit may be ignored by the IRD.

4.1.6.4 Copyright and original_or_copy

Encoding: The copyright and **original_or_copy** bits may be set as appropriate.

Decoding: The IRD need not interpret these bits. *The setting of these bits shall not be altered in any digital output from the IRD.*

4.1.6.5 Trick mode fields

This clause covers the following fields:

- trick_mode_control;
- field_id;
- intra_slice_refresh;
- frequency_truncation;
- field_rep_cntrl.

Encoding: *These trick mode fields shall not be transmitted in a broadcast bitstream. Bitstreams for other applications (e.g. for non-broadcast interactive services, storage applications, etc.) may use these fields.*

Decoding: The IRD may skip over any data which is flagged as being in a trick mode, if it does not support decoding of trick modes. If the IRD has a digital interface intended for digital VCR applications, it is recommended that it supports decoding of trick modes as indicated in clause 4.2.2.

4.1.6.6 additional_copy_info

Encoding: This field may be used as appropriate.

Decoding: The IRD need not interpret this field. *The coding of the field shall not be altered in any digital output from the IRD.*

4.1.6.7 Optional fields

This clause covers the following fields:

- ESCR;
- ESCR_extension;
- ES_rate;
- previous_PES_packet_CRC;
- PES_private_data;
- pack_header();
- program_packet_sequence_counter;
- MPEG1_MPEG2_identifier;
- original_stuff_length;
- P-STD_buffer_scale;
- P-STD_buffer_size.

Encoding: These fields are optional in a DVB bitstream. *The flags that indicate the presence or absence of each of these fields shall be set appropriately.*

Decoding: *The IRD shall be able to accept bitstreams which contain these fields.* The IRD may ignore the data within the fields.

4.1.6.8 PES_extension_field

For MPEG-2 Video Bitstreams and H.264/AVC Bitstreams the **PES_extension_field** data field is currently "reserved".

Encoding: *This extension field shall not be coded unless specified in the future by MPEG.*

Decoding: *The IRD shall be able to accept bitstreams which contain this field.* The IRD may ignore the data within the field.

For SVC Bitstreams the **PES_extension_field** data field is used to provide the **TREF** field as defined in clauses 2.4.3.7 and 2.14.3.4 of ITU-T Recommendation H.222.0 / ISO/IEC 13818-1 [1] which identifies, if present, the corresponding SVC dependency representation of the same access unit in a corresponding video sub-bitstream.

Encoding: *This extension field shall be coded as specified in ITU-T Recommendation H.222.0 / ISO/IEC 13818-1 [1].*

Decoding: *The IRD shall be able to accept bitstreams which contain this field. The IRD shall use this field according to ITU-T Recommendation H.222.0 / ISO/IEC 13818-1 [1].*

For VC-1 Bitstreams the **PES_extension_field** data field is used to provide the **stream_id_extension** field which identifies this stream as a VC-1 bitstream.

Encoding: *This extension field shall be coded as defined in SMPTE RP 227 [21].*

Decoding: *The IRD shall be able to accept bitstreams which contain this field.*

4.1.6.9 Multiple video pictures per PES packet

For MPEG-2 video Bitstreams, while there is no restriction against multiple video pictures in a single PES packet, there may be some MPEG-2 decoders that do not support this.

- Encoding: The encoder should not put multiple video pictures in a single PES packet.
- Decoding: The IRD may be able to accept and decode bitstreams which contain multiple video pictures in a single PES.

For H.264/AVC Bitstreams, multiple video pictures are allowed in a single PES packet.

- Encoding: *A PES packet per access unit start shall be sent unless multiple access units can be placed in a single transport packet. In this last case, the encoder may put multiple complete access units in a single PES packet. In applications where the IRD is capable of decoding and displaying bitstreams that contain fractions of Access Units, the PES packet may contain fractions of Access Units and encoders are recommended to utilize this option for instance when bitrate savings can be achieved.*

An access unit with H.264/AVC RAP shall be the first access unit in the PES packet (see clause 4.1.5.1) and shall always be preceded by a PES header. Changes to picture size or frame rate cannot occur between access units in the same PES packet. The maximum increment in PTS values between two successive PES packets shall be less than 700 ms with the exception case where video is coded using still pictures where the spacing shall be less than 5 seconds. A single PES packet shall not contain multiple H.264/AVC Still pictures or multiple H.264/AVC RAPs.

NOTE 1: Usage of multiple pictures per PES packet as per the above represents a very constrained set of conditions under which this may occur. Use of this feature potentially introduces complexity in timing extraction. Therefore, it is recommended that this feature is only used where the consequential bitrate savings are essential and the potential system effects are considered.

- Decoding: *The IRD shall support decoding and displaying bitstreams, which contain multiple complete access units in a single PES packet. It is strongly recommended that the IRD also supports decoding and displaying bitstreams that contain fractions of access units in PES packet.*

For SVC Bitstreams, multiple video pictures are not allowed in a single PES packet.

- Encoding: *A single PES packet per SVC dependency representation shall be sent.*
- Decoding: *The IRD shall support decoding and displaying bitstreams, which contain a single complete SVC dependency representation in a single PES packet.*

For VC-1 Bitstreams, multiple video pictures are allowed in a single PES packet.

- Encoding: *A PES packet per access unit start shall be sent unless if multiple access units can be placed in a single transport packet. In this last case, the encoder may put multiple complete access units in a single PES packet. In applications where the IRD is capable of decoding and displaying bitstreams that contain fractions of access unit, the PES packet may contain fractions of access units and encoders are recommended to utilize this option for instance when bitrate savings can be achieved.*

An access unit with a VC-1 Access Point shall be the first access unit in the PES packet (see clause 4.1.5.1) and shall always be preceded by a PES header.

NOTE 2: Usage of multiple pictures per PES packet as per the above represents a very constrained set of conditions under which this may occur. Use of this feature potentially introduces complexity in timing extraction. Therefore, it is recommended that this feature is only used where the consequential bitrate savings are essential and the potential system effects are considered.

- Decoding: *The IRD shall support decoding and displaying bitstreams, which contain multiple complete access units in a single PES packet. It is strongly recommended that the IRD also supports decoding and displaying bitstreams that contain fractions of access units in PES packet.*

For MVC Bitstreams, multiple video pictures are not allowed in a single PES packet.

Encoding: *A single PES packet per MVC view component shall be sent.* Additionally, the following applies:

- The first byte of a PES packet payload for the Base (Dependent) View video elementary stream shall be the first byte of the Base (Dependent) View component.
- If the coded picture has frame structure, one PES packet containing the view component shall contain only one frame.
- If the coded picture has field structure, one PES packet containing the view component shall contain a field picture.

Decoding: *The IRD shall support decoding and displaying of MVC Stereo bitstreams, consisting of an MVC Stereo Base view bitstream and an MVC Stereo Dependent view bitstream, which are both sent in separate elementary streams.*

4.1.6.10 Presentation Time Stamp and Decoding Time Stamp occurrence

For H.264/AVC Bitstreams:

Encoding: *Every PES header shall contain the Presentation Time Stamp and the Decoding Time Stamp (only if it differs from the Presentation Time Stamp) of the first access unit in the PES packet. The start of the first access unit shall occur in the same transport packet as the PES header or the packet of same PID immediately following the packet with the PES header, if the data preceding the access unit start code forces the access unit start code into the next transport packet. When a PES packet contains multiple access units, for any access units following the first access unit in the same PES packet the H.264/AVC syntax elements num_units_in_tick, time_scale, pic_struct (if present), and the value of the H.264/AVC variables TopFieldOrderCnt and BottomFieldOrderCnt of the access unit shall allow the derivation of Presentation Time Stamp and the Decoding Time Stamp for the access unit.*

Decoding: *If Presentation Time Stamp is available and Decoding Time Stamp is not available for the first access unit in the PES packet, the H.264/AVC IRD shall set the Decoding Time Stamp equal to the Presentation Time Stamp (per ISO/IEC 13818-1 [1]). The Presentation Time Stamp and the Decoding Time Stamp of any access units following the first access unit in the same PES packet shall be derived using the H.264/AVC syntax elements num_units_in_tick, time_scale, pic_struct (if present), and the value of the H.264/AVC variables TopFieldOrderCnt and BottomFieldOrderCnt of the access unit.*

For SVC Bitstreams:

Encoding: *Every PES header shall contain the Presentation Time Stamp and the Decoding Time Stamp (only if it differs from the Presentation Time Stamp) of the SVC dependency representation in the PES packet. The start of the SVC dependency representation shall occur in the same transport packet as the PES header or the packet of same PID immediately following the packet with the PES header, if the data preceding the SVC dependency representation start code forces the SVC dependency representation code into the next transport packet.*

Decoding: *If a Presentation Time Stamp is available and a Decoding Time Stamp is not available for the SVC dependency representation in the PES packet, the SVC IRD shall set the Decoding Time Stamp equal to the Presentation Time Stamp (per ITU-T Recommendation H.222.0/ISO/IEC 13818-1 [1]).*

For MVC Bitstreams:

Encoding: *Every PES header shall contain the Presentation Time Stamp and the Decoding Time Stamp (only if it differs from the Presentation Time Stamp) of the MVC Stereo AU in the PES packet.*

The PTS shall be the same for Base and Dependent view components within the same MVC Stereo AU, as per ITU-T Recommendation H.222.0 ISO/IEC 13818-1 [1].

The DTS, when present, shall be the same for Base and Dependent view components within the same MVC Stereo AU, as per ITU-T Recommendation H.222.0 ISO/IEC 13818-1 [1].

Decoding: *If a Presentation Time Stamp is available and a Decoding Time Stamp is not available for the MVC view component(s) in the PES packet, the MVC IRD shall set the Decoding Time Stamp equal to the Presentation Time Stamp (per ITU-T Recommendation H.222.0 ISO/IEC 13818-1 [1]).*

Within the accuracy of their respective clocks, the Decoding Time Stamp and Presentation Time Stamp shall indicate the same instant in time as the nominal CPB removal time and the DPB output time in the HRD respectively when picture timing SEI information is transmitted (per clause 2.4.3.7 ISO/IEC 13818-1 [1]). This ensures consistency between the STD model of ISO/IEC 13818-1 [1] and the HRD model of ITU-T Recommendation H.264 / ISO/IEC 14496-10 [16]. See clause 0 for more details on HRD conformance.

4.1.7 Program Specific Information (PSI) (ITU-T Recommendation H.222.0 / ISO/IEC 13818-1 clause 2.4.4)

The data formats for the Transport Stream Description Table (TSDT) and Network Information Table (NIT) in DVB bitstreams are given in EN 300 468 [6]. The present document also defines additional tables for service information which use Program Specific Information (PSI) private_section structure defined in ITU-T Recommendation H.222.0 / ISO/IEC 13818-1 [1].

It is recommended that the Program Association Table (PAT) and Program Map Table (PMT) are repeated with a maximum time interval of 100 ms between repetitions. It is recommended that the Transport Stream Description Table (TSDT) is repeated with a maximum time interval of 10 seconds between repetitions.

4.1.8 Program and elementary stream descriptors (ITU-T Recommendation H.222.0 / ISO/IEC 13818-1 clause 2.6)

4.1.8.1 video_stream_descriptor and audio_stream_descriptor

For MPEG-2 Video Bitstreams:

Encoding: *The **video_stream_descriptor** shall be used to indicate video streams containing still picture data, otherwise these descriptors may be used when appropriate. If **profile_and_level_indication** is not present, then the video bitstream shall comply with the constraints of Main Profile at Main Level. The appropriate **profile_and_level_indication** field shall always be transmitted for Profiles and Levels other than Main Profile at Main Level.*

*If the **audio_stream_descriptor** is not present, then the audio bitstream shall not use sampling frequencies of 16 kHz, 22,05 kHz or 24 kHz, and all audio frames in the stream shall have the same bitrate.*

Decoding: The IRD may use these descriptors when present to determine if it is able to decode the streams.

NOTE: The video_stream_descriptor defined in this clause is not applicable to H.264/AVC, SVC or VC-1 bitstreams.

4.1.8.2 hierarchy_descriptor

For audio Bitstreams:

Encoding: *The **hierarchy_descriptor** shall be used if, and only if, audio is coded as more than one hierarchical layer.*

For SVC Bitstreams:

Encoding: *The **hierarchy_descriptor** shall be used according to ITU-T Recommendation H.222.0 / ISO/IEC 13818-1 [1].*

Decoding: *The IRD shall use the **hierarchy_descriptor** according to ITU-T Recommendation H.222.0 / ISO/IEC 13818-1 [1].*

4.1.8.3 registration_descriptor

For MPEG-2 Video, H.264/AVC and SVC Bitstreams:

Encoding: The **registration_descriptor** may be used when appropriate.

Decoding: The IRD need not make use of this descriptor.

For VC-1 Bitstreams, the following applies:

Encoding: *A **registration_descriptor** shall be used for the signalling of VC-1 bitstreams as defined in SMPTE RP 227 [21]. One and only one **registration_descriptor** shall be present.*

Decoding: *The IRD shall decode and process the VC-1 registration descriptor to access information relevant to the encoded bitstream.*

4.1.8.4 data_stream_alignment_descriptor

For MPEG-2 Video, H.264/AVC, SVC and MVC Stereo Bitstreams:

Encoding: The **data_stream_alignment_descriptor** may be used when appropriate.

Decoding: The IRD need not make use of this descriptor.

For VC-1 Bitstreams, the following applies:

Encoding: *The **data_stream_alignment_descriptor** shall not be used. See SMPTE RP 227 [21] for a functional equivalent of the **data_stream_alignment_descriptor** that is specific to VC-1 bitstreams.*

4.1.8.5 target_background_grid_descriptor

Encoding: *The **target_background_grid_descriptor** shall be used when the horizontal or vertical resolution is other than 720×576 pixels for a 25 Hz bitstream or is other than 720×480 pixels for a 30 Hz bitstream, otherwise its use is optional.*

Decoding: *If this descriptor is absent, a default grid of 720×576 pixels shall be assumed by a 25 Hz IRD, a default grid of 720×480 pixels shall be assumed by a 30 Hz IRD. The display of correctly windowed video on background grids other than 720×576 pixels is optional for a 25 Hz SDTV IRD, the display of correctly windowed video on background grids other than 720×480 pixels is optional for a 30 Hz SDTV IRD. The HDTV IRD shall read this descriptor, when present, to override the default values.*

4.1.8.6 video_window_descriptor

Encoding: The **video_window_descriptor** may be used when appropriate, to indicate the required position of the video window on the screen.

Decoding: *The IRD shall read this descriptor, when present, and position the video window accordingly.*

4.1.8.7 Conditional Access CA_descriptor

Encoding: *The **CA_descriptor** shall be encoded as defined in TS 101 289 [i.15].*

Decoding: *The IRD shall interpret this descriptor as defined in TS 101 289 [i.15].*

4.1.8.8 ISO_639_Language_descriptor

Encoding: *The **ISO_639_Language_descriptor** shall be present if more than one audio (or video) stream with different languages is present within a program. It is optional otherwise. The use of the ISO_639_Language_descriptor is recommended for all audio, video and data streams.*

Decoding: *The IRD shall use the data from this descriptor to assist the selection of appropriate audio (or video) stream of program, if more than one stream is available.*

4.1.8.9 system_clock_descriptor

Encoding: It is recommended that the **system_clock_descriptor** is included in the program_info part of the Program Map Table for each program.

Decoding: The IRD need not make use of this descriptor.

4.1.8.10 multiplex_buffer_utilization_descriptor

Encoding: The **multiplex_buffer_utilization_descriptor** may be used when appropriate.

Decoding: The IRD need not make use of this descriptor.

4.1.8.11 copyright_descriptor

Encoding: The **copyright_descriptor** may be used when appropriate.

Decoding: The IRD need not make use of this descriptor.

4.1.8.12 maximum_bitrate_descriptor

Encoding: The **maximum_bitrate_descriptor** may be used when appropriate.

Decoding: The IRD need not make use of this descriptor.

4.1.8.13 private_data_indicator_descriptor

Encoding: The **private_data_indicator_descriptor** may be used when appropriate.

Decoding: The IRD need not make use of this descriptor.

4.1.8.14 smoothing_buffer_descriptor

Encoding: It is recommended that the **smoothing_buffer_descriptor** is included in the program_info part of the Program Map Table for each program.

Decoding: The IRD need not make use of this descriptor, but the information may be of assistance to digital VCRs.

4.1.8.15 STD_descriptor

Encoding: *The **STD_descriptor** shall be used as specified in ITU-T Recommendation H.222.0 / ISO/IEC 13818-1 [1].*

Decoding: The IRD need not make use of this descriptor.

4.1.8.16 IBP_descriptor

Encoding: The **IBP_descriptor** may be used when appropriate.

Decoding: The IRD need not make use of this descriptor.

4.1.8.17 MPEG-4_audio_descriptor

For MPEG-4 AAC, MPEG-4 HE AAC and MPEG-4 HE AAC v2:

Encoding: The **MPEG-4_audio_descriptor** may be used when appropriate.

Decoding: The IRD need not make use of this descriptor.

4.1.8.18 AVC_video_descriptor

For H.264/AVC:

Encoding: The **AVC_video_descriptor** may be used when appropriate. *The **AVC_video_descriptor** shall be used to signal presence of H.264/AVC still pictures within the coded video sequence (see clause 5.5.4.3).*

Decoding: The IRD need not make use of this descriptor. However, the information may assist in support for H.264/AVC still pictures (see clause 5.5.4.3).

For SVC:

Encoding: The **AVC_video_descriptor** may be used when appropriate. *The **AVC_video_descriptor** shall be used to signal presence of H.264/AVC still pictures within the coded video sequence (see clause 5.5.4.3).*

Decoding: The IRD need not make use of this descriptor. However, the information may assist in support for H.264/AVC still pictures (see clause 5.5.4.3) and may assist the IRD in selecting the video sub-bitstreams to tune in.

For MVC:

Encoding: The **AVC_video_descriptor** may be used when appropriate. *The **AVC_video_descriptor** shall be used to signal presence of H.264/AVC still pictures within the MVC Stereo Base view coded video sequence (see clause 5.5.4.3).*

NOTE: *The **AVC_video_descriptor** shall not be associated with the MVC Stereo Dependent view bitstream.*

Decoding: The IRD need not make use of this descriptor. However, the information may assist in support for H.264/AVC still pictures (see clause 5.5.4.3) and may assist the IRD in selecting the video sub-bitstreams to tune in.

4.1.8.19 SVC_extension_descriptor

For SVC:

Encoding: The **SVC_extension_descriptor** may be used when appropriate.

*If the **SVC_extension_descriptor** is present in an SVC video sub-bitstream (i.e. a video sub-bitstream with *dependency_id* greater than 0), then the syntax element **no_sei_nal_unit_present** shall be set equal to 1.*

Decoding: The IRD need not make use of this descriptor. However, the information conveyed assists the re-assembling process of video sub-bitstreams and may also assist the IRD in selecting the video sub-bitstreams to tune in.

4.1.8.20 STD audio buffer size

For AC-3 and Enhanced AC-3:

- It is recommended that for AC-3 and Enhanced AC-3 audio in a DVB system, the main audio buffer size (BS_n) has a fixed value of 5 696 bytes.

For MPEG-4 AAC, MPEG-4 HE AAC and MPEG-4 HE AAC v2:

- It is recommended that for MPEG-4 AAC, MPEG-4 HE AAC and MPEG-4 HE AAC v2 audio in a DVB system, the main audio buffer size (BS_n) has a value of 3 584 bytes for level 2 decoders and 8 976 bytes for level 4 decoders as defined in ITU-T Recommendation H.222.0 / ISO/IEC 13818-1 [1], clause 2.11.2.2.
- Refer to ITU-T Recommendation H.222.0 / ISO/IEC 13818-1 [1] for the derivation of (BS_n) for audio elementary streams.

4.1.8.21 Use of the DVB-SI component_descriptor and multilingual_component_descriptor

- Semantics: The semantics of the **component_descriptor** and **multilingual_component_descriptor** are defined in EN 300 468 [6]. The stream_content and component_type assigned values for DVB AC-3, Enhanced AC-3, MPEG-4 HE AAC, MPEG-4 HE AAC v2, DTS and DTS-HD audio streams are listed in EN 300 468 [6], table 26.
- Encoding: *The values for the elements of the **component_descriptor** and **multilingual_component_descriptor** shall be set in accordance with EN 300 468 [6].*
- Decoding: *These fields shall be read by the IRD, and the IRD shall interpret these fields to indicate the type of audio service present.*

4.1.8.22 AC-3_descriptor

- Semantics: The **AC-3_descriptor** syntax provides information about individual AC-3 elementary streams within a DVB transport stream that are to be identified in the PSI PMT sections. The **AC-3_descriptor** is located in the PMT and the Selection Information Table of the DVB SI Tables defined in EN 300 468 [6] and is defined in EN 300 468 [6], annex D.
- Encoding: *The **AC-3_descriptor** shall be included once in a program map section following the relevant ES_info_length field for any AC-3 audio stream coded in accordance with TS 102 366 [12] (not including annex E) that is included in a DVB transport stream.*
- Decoding: *This descriptor shall be read and interpreted by the IRD.*

4.1.8.23 Enhanced_AC-3_Descriptor

- Semantics: The **Enhanced_AC-3_descriptor** syntax provides information about individual Enhanced AC-3 elementary streams within a DVB transport stream that are to be identified in the PSI PMT sections. The **Enhanced_AC-3_descriptor** is located in the PMT and the Selection Information Table of the DVB SI Tables defined in EN 300 468 [6] and is defined in EN 300 468 [6], annex D.
- Encoding: *The **Enhanced_AC-3_descriptor** shall be included once in a program map section following the relevant ES_info_length field for any Enhanced AC-3 audio stream coded in accordance with TS 102 366 [12], annex E that is included in a DVB transport stream.*
- Decoding: *This descriptor shall be read and interpreted by the IRD.*

4.1.8.24 Void

4.1.8.24.1 void

4.1.8.24.2 void

4.1.8.24.3 void

4.1.8.25 DTS_descriptor

- Semantics: The **DTS_descriptor** syntax provides information about individual DTS elementary streams within a DVB transport stream that are to be identified in the PSI PMT sections. The **DTS_descriptor** is located in the PMT and the Selection Information Table of the DVB SI Tables defined in EN 300 468 [6] and is defined in EN 300 468 [6], annex G.
- Encoding: *The **DTS_descriptor** shall be included once in a program map section following the relevant ES_info_length field for any DTS audio stream coded in accordance with TS 102 114 [15] that is included in a DVB transport stream.*
- Decoding: *This descriptor shall be read and interpreted by the IRD.*

4.1.8.26 AAC_descriptor

- Semantics: The MPEG-4 **AAC_descriptor** syntax provides information about individual MPEG-4 AAC, MPEG-4 HE AAC or HE AAC v2 elementary streams within a DVB transport stream that are to be identified in the PSI PMT sections. The **AAC_descriptor** is located in the PMT and the Selection Information Table of the DVB SI Tables defined in EN 300 468 [6] and is defined in EN 300 468 [6], annex H.
- Encoding: *The **AAC_descriptor** shall be included once in a program map section following the relevant ES_info_length field for any MPEG-4 AAC, MPEG-4 HE AAC or MPEG-4 HE AAC v2 audio stream coded in accordance with ISO/IEC 14496-3 [17] that is included in a DVB transport stream.*
- Decoding: *This descriptor shall be read and interpreted by the IRD.*

4.1.8.27 MPEG-4 audio extension descriptor

- Semantics: The **MPEG-4 audio extension descriptor** syntax provides information about presence of MPEG Surround data in conjunction with MPEG-1 Layer II, MPEG-4 AAC, MPEG-4 HE AAC or HE AAC v2 elementary streams within a DVB transport stream. The **MPEG-4 audio extension_descriptor** is located in the PMT and the Selection Information Table of the DVB SI Tables defined in EN 300 468 [6] and is defined in ISO/IEC 13818-1 AMD 1 [28].
- Encoding: *If MPEG Surround data according to [29] and [31] is transmitted in conjunction with MPEG-4 AAC, MPEG-4 HE AAC or MPEG-4 HE AAC v2 elementary streams, the **MPEG-4 audio extension_descriptor** shall be included once in a program map section following the relevant ES_info_length field for any MPEG-4 AAC, MPEG-4 HE AAC or MPEG-4 HE AAC v2 audio stream coded in accordance with ISO/IEC 14496-3 [17] that is included in a DVB transport stream. One **audio profile level indication** shall be specified for the AAC, HE AAC or HE AAC v2 part. Additionally, one **audio profile level indication** shall be specified for the MPEG Surround part. If MPEG Surround data according to [29] and [31] is transmitted in conjunction with MPEG-1 Layer II elementary streams, the **MPEG-4 audio extension_descriptor** shall be included once in a program map section following the relevant ES_info_length field for any MPEG-1 Layer II audio stream coded in accordance with ISO/IEC 11172-3 [9] that is included in a DVB transport stream. One **audio profile level indication** for the MPEG Surround part shall be specified.*
- Decoding: *In case the IRD is capable of decoding MPEG Surround, this descriptor shall be read and interpreted by the IRD.*

4.1.8.28 MVC_extension_descriptor

For MVC:

- Encoding: *The MVC extension descriptor carried in the PMT shall be present for the Dependent view component.*
- Also, the following applies:
- The syntax element **no_prefix_nal_unit_present** shall be set equal to 1.
 - The syntax of the **view_association_not_present** and **base_view_is_left_eyeview** shall be set accordingly to indicate which view, left or right, has been assigned to the Base view component by the content author.
- Decoding: *An IRD shall use this descriptor to determine the association of left view and right view to the Base and Dependent view components.*
- The two fields, view_association_not_present and base_view_is_left_eyeview, of the MVC extension descriptor shall be set in accordance with the Multiview view position SEI message.*
- NOTE: In the case of inconsistencies between MVC extension descriptor and Multiview view position SEI message, the latter takes precedence.

4.1.8.29 DTS-HD_descriptor

Semantics: The **DTS-HD_descriptor** syntax provides information about individual DTS-HD elementary streams within a DVB transport stream that are to be identified in the PSI PMT sections. The **DTS-HD_descriptor** is located in the PMT and the Selection Information Table of the DVB SI Tables defined in EN 300 468 [6] and is defined in EN 300 468 [6], annex G.

Encoding: *The **DTS-HD_descriptor** shall be included once in a program map section following the relevant ES_info_length field for any DTS audio stream coded in accordance with TS 102 114 [15] that is included in a DVB transport stream.*

Decoding: *This descriptor shall be read and interpreted by the IRD.*

4.1.9 Compatibility with ISO/IEC 11172-1 (ITU-T Recommendation H.222.0 / ISO/IEC 13818-1 clause 2.8)

Decoding: Compatibility with ISO/IEC 11172-1 [8] (MPEG-1 Systems) is optional.

4.1.10 Storage Media Interoperability

It is recommended that the total bitrate of the set of components, associated PMT and PCR packets for an SDTV service anticipated to be recorded by a consumer, should not exceed 9 000 000 bit/s. It is recommended that the total bitrate of the set of components, associated PMT and PCR packets for an HDTV service anticipated to be recorded by a consumer, should not exceed 28 000 000 bit/s.

It is recommended that the parameters sb_size and sb_leak_rate in the smoothing_buffer_descriptor remain constant for the duration of an event. The value of the sb_leak_rate should be the peak attained during the event. The short_smoothing_buffer_descriptor is defined in EN 300 468 [6] and guidelines for its use are provided in TS 101 211 [7].

4.2 Bitstreams from storage applications and IRDs with digital interfaces

This clause covers both the treatment of Partial Transport Streams which result from external program selection and Trick Play information received from a storage device. MPEG-2 PSI and DVB SI Tables for use specifically in storage applications are defined in EN 300 468 [6].

4.2.1 Partial Transport Streams

Partial transport streams for transfer on a digital interface, e.g. for digital VCR applications, have been defined in IEC CD - 100C/1883. A Partial Transport Stream may be created by selection of Transport Stream Packets from one or more program(s), including PSI Packets.

Encoding: *The Partial Transport Stream shall be fully MPEG compliant with reference to MPEG-2 "Extension for Real-Time-Interface for systems decoders" (ISO/IEC 13818-9 [4]).*

Decoding: *Devices equipped with a digital interface intended for digital VCR applications shall accept the bursty character of a Partial Transport Stream with gaps of variable length between the Transport Stream Packets.*

4.2.2 Decoding of Trick Play data (ITU-T Recommendation H.222.0 / ISO/IEC 13818-1 clause 2.4.3.7)

Encoding: *Trick mode operation shall be signalled by use of the DSM_trick_mode flag in the header of the video Packetized Elementary Stream (PES) packets. During trick mode playback the storage device shall construct a bitstream which is syntactically and semantically correct, except as outlined in the note below.*

Decoding: It is recommended that devices decode the DSM_trick_mode_flag and the eight bit trick mode field. *Devices which decode the trick mode data shall follow the normative requirements detailed in ITU-T Recommendation H.222.0 / ISO/IEC 13818-1 [1], 2 for all values of the trick_mode_control field.*

NOTE: Trick Mode Semantic Constraints.

The bitstream delivered to the decoder during trick mode shall comply with the syntax defined in the MPEG-2 standard. However, for the following video syntax elements, semantic exceptions apply in the presence of the DSM_trick_mode field:

- bit_rate;
- vbv_delay;
- repeat_first_field;
- v_axis_positive;
- field_sequence;
- subcarrier;
- burst_amplitude;
- subcarrier_phase.

A decoder cannot rely on the values encoded in these fields when in trick mode.

Similarly, for the systems layer, the following semantic exceptions apply in the presence of the DSM_trick_mode field:

- maximum spacing of PSI information may exceed 400 ms;
- maximum spacing of Presentation Time Stamp or Decoding Time Stamp occurrences may exceed 700 ms;
- PES packets may be void of video data to indicate a change in trick mode byte;
- a PES packet void of video data may contain a Presentation Time Stamp to indicate effective presentation time of new trick mode control;
- when trick_mode status is true, the elementary stream buffers in the T-STD may underflow.

5 Video

This clause describes the guidelines for encoding MPEG-2 video, or H.264/AVC video, or VC-1 video in DVB broadcast bitstreams, and for decoding this bitstream in the IRD.

Clause 5.1 applies to 25 Hz MPEG-2 SDTV IRDs and broadcasts intended for reception by such IRDs.

Clause 5.2 applies to 25 Hz MPEG-2 HDTV IRDs and broadcasts intended for reception by such IRDs.

Clause 5.3 applies to 30 Hz MPEG-2 SDTV IRDs and broadcasts intended for reception by such IRDs.

Clause 5.4 applies to 30 Hz MPEG-2 HDTV IRDs and broadcasts intended for reception by such IRDs.

Clause 5.5 applies to all H.264/AVC IRDs and broadcasts intended for reception by such IRDs.

Clause 5.6 applies to H.264/AVC SDTV IRDs and broadcasts intended for reception by such IRDs.

Clause 5.7 applies to H.264/AVC HDTV IRDs and broadcasts intended for reception by such IRDs.

Clause 5.8 applies to SVC HDTV IRDs and broadcasts intended for reception by such IRDs.

Clause 5.9 applies to 25 Hz VC-1 SDTV IRDs and broadcasts intended for reception by such IRDs.

Clause 5.10 applies to 25 Hz VC-1 HDTV IRDs and broadcasts intended for reception by such IRDs.

Clause 5.11 applies to 30 Hz VC-1 SDTV IRDs and broadcasts intended for reception by such IRDs.

Clause 5.12 applies to 30 Hz VC-1 HDTV IRDs and broadcasts intended for reception by such IRDs.

Clause 5.13.1 applies to all MVC Stereo HDTV IRDs and broadcasts intended for reception by such IRDs.

Clause 5.13.2 applies to 25 Hz MVC Stereo HDTV IRDs and broadcasts intended for reception by such IRDs.

Clause 5.13.3 applies to 30 Hz MVC Stereo HDTV IRDs and broadcasts intended for reception by such IRDs.

To allow full compliance to the MPEG-2, H.264/AVC and VC-1 standards and upward compatibility with future enhanced versions, a DVB IRD shall be able to skip over data structures which are currently "reserved", or which correspond to functions not implemented by the IRD.

This clause is based on ITU-T Recommendation H.262 / ISO/IEC 13818-2 [2], ITU-T Recommendation H.264 / ISO/IEC 14496-10 [16] and SMPTE ST 421 [20].

The following clauses do not imply that either MPEG-2 video, H.264/AVC video or VC-1 video are mandatory. *The codecs that a given IRD supports will define which of the following clauses the IRD shall comply with.*

5.1 25 Hz MPEG-2 SDTV IRDs and Bitstreams

The video encoding shall conform to ITU-T Recommendation H.262 / ISO/IEC 13818-2 [2]. Some of the parameters and fields are not used in the DVB System and these restrictions are described below. The IRD design shall be made under the assumption that any legal structure as permitted by ITU-T Recommendation H.262 / ISO/IEC 13818-2 [2] may occur in the broadcast stream even if presently reserved or unused.

5.1.1 Profile and level

Encoding: *Encoded bitstreams shall comply with the Main Profile Main Level restrictions, as described in ITU-T Recommendation H.262 / ISO/IEC 13818-2 [2], clause 8.2. The **profile_and_level_indication** is "01001000" or, if appropriate, "0nnnnnnn", where "0nnnnnnn">"01001000", indicating a "simpler" profile or level than Main Profile, Main Level.*

Decoding: *The 25 Hz MPEG-2 SDTV IRD shall support the decoding of Main Profile Main Level bitstreams. Support for profiles and levels beyond Main Profile, Main Level is optional. If the IRD encounters an extension which it cannot decode, such as one whose identification code is Reserved, Picture Sequence Scaleable, Picture Spatial Scaleable or Picture Temporal Scaleable, it shall discard the following data until the next start code (to allow backward compatible extensions to be added in the future).*

5.1.2 Frame rate

Encoding: *The frame rate shall be 25 Hz, i.e. **frame_rate_code** is "0011".*

Still pictures may be encoded by use of a video sequence consisting of a single intra-coded picture (see definition of still pictures in ITU-T Recommendation H.222.0 / ISO/IEC 13818-1 [1], clause 2.1.70).

Decoding: *All 25 Hz MPEG-2 SDTV IRDs shall support the decoding and display of video material with a frame rate of 25 Hz interlaced (i.e. **frame_rate_code** of "0011"). Support of other frame and field rates is optional.*

25 Hz MPEG-2 SDTV IRDs shall be capable of decoding and displaying still pictures, i.e. video sequences consisting of a single intra-coded picture (see definition of still pictures in ITU-T Recommendation H.222.0 / ISO/IEC 13818-1 [1], clause 2.1.70).

5.1.3 Aspect ratio

Encoding: *The source aspect ratio in 25 Hz MPEG-2 SDTV bitstreams shall be either 4:3, 16:9 or 2.21:1. Note that decoding of 2.21:1 aspect ratio is optional for the 25 Hz MPEG-2 SDTV IRD.*

*The **aspect_ratio_information** in the sequence header shall have one of the following three values:*

- 4:3 aspect ratio source: "0010";
- 16:9 aspect ratio source: "0011";
- 2.21:1 aspect ratio source: "0100".

It is recommended that pan vectors for a 4:3 window are included in the transmitted bitstream when the source aspect ratio is 16:9 or 2.21:1. *The vertical component of the transmitted pan vector shall be zero.*

*If pan vectors are transmitted then the **sequence_display_extension** shall be present in the bitstream and the **aspect_ratio_information** shall be set to '0010' (4:3 display). The **display_vertical_size** shall be equal to the **vertical_size**. The **display_horizontal_size** shall contain the resolution of the target 4:3 display. The value of the **display_horizontal_size** field may be calculated by the following equation:*

$$\text{display_horizontal_size} = \frac{4}{3} \times \frac{\text{horizontal_size}}{\text{source aspect ratio}}$$

Table 3 gives some typical examples.

Table 3: Values for display_horizontal_size

horizontal_size × vertical_size	Source aspect ratio	Display_horizontal_size
720 × 576	16:9	540
544 × 576	16:9	408
480 × 576	16:9	360
352 × 576	16:9	264
352 × 288	16:9	264

Decoding: *The 25 Hz MPEG-2 SDTV IRD shall be able to decode bitstreams with values of **aspect_ratio_information** of "0010" and "0011", corresponding to 4:3 and 16:9 aspect ratio respectively. If the IRD has a digital interface, this should be capable of outputting bitstreams with aspect ratios which are not directly supported by the IRD to allow their decoding and display via an external unit.*

All 25 Hz MPEG-2 SDTV IRDs shall support the use of pan vectors and up sampling to allow a 4:3 monitor to give a full-screen display of a selected portion of a 16:9 coded picture with the correct aspect ratio. IRDs implementing the 2.21:1 aspect ratio should support the use of pan vectors and up sampling to allow a 4:3 monitor to give a full-screen display of a selected portion of the 2.21:1 picture with the correct aspect ratio. Support for pan vectors with non-zero vertical components is optional. When no pan vectors are present in the transmitted bitstream, the central portion of the wide-screen picture shall be displayed. The support of vertical resampling to obtain the correct aspect ratio for a letterbox display of a 16:9 or 2.21:1 coded picture on a 4:3 monitor is optional.

5.1.4 Luminance resolution

Encoding: *The encoded picture shall have a full-screen luminance resolution (horizontal × vertical) of one of the following values:*

- 720 × 576;
- 544 × 576;
- 480 × 576;

- 352 × 576;
- 352 × 288.

In addition, non full-screen pictures may be encoded for display at less than full-size (when using one of the standard up-conversion ratios at the IRD).

Decoding: The 25 Hz MPEG-2 SDTV IRD *shall be capable of decoding pictures with luminance resolutions as shown in table 4 and applying up sampling to allow the decoded pictures to be displayed at full-screen size. In addition, IRDs shall be capable of decoding lower picture resolutions and displaying them at less than full-size after using one of the standard up-conversions, e.g. a horizontal resolution of 704 pixels within the 720 pixels full-screen display.*

Table 4: Resolutions for Full-screen Display from 25 Hz MPEG-2 SDTV IRD

Coded Picture		Displayed Picture Horizontal up sampling	
Luminance resolution (horizontal × vertical)	Aspect Ratio	4:3 Monitors	16:9 Monitors
720 × 576	4:3	× 1	× 3/4 (see note 1)
	16:9	× 4/3 (see note 2)	× 1
	2.21:1	× 5/3 (see note 3)	× 5/4 (see note 4)
544 × 576	4:3	× 4/3	× 1 (see note 1)
	16:9	× 16/9 (see note 2)	× 4/3
	2.21:1	× 20/9 (see note 3)	× 5/3 (see note 4)
480 × 576	4:3	× 3/2	× 9/8 (see note 1)
	16:9	× 2 (see note 2)	× 3/2
	2.21:1	× 5/2 (see note 3)	× 15/8 (see note 4)
352 × 576	4:3	× 2	× 3/2 (see note 1)
	16:9	× 8/3 (see note 2)	× 2
	2.21:1	× 10/3 (see note 3)	× 5/2 (see note 4)
352 × 288	4:3	× 2	× 3/2 (see note 1)
	16:9	× 8/3 (see note 2)	× 2
	2.21:1	× 10/3 (see note 3)	× 5/2 (see note 4)
		(and vertical up sampling × 2)	(and vertical up sampling × 2)
NOTE 1: Up sampling of 4:3 pictures for display on a 16:9 monitor is optional in the IRD, as 16:9 monitors can be switched to operate in 4:3 mode.			
NOTE 2: The up sampling with this value is applied to the pixels of the 16:9 picture to be displayed on a 4:3 monitor.			
NOTE 3: The up sampling with this value is applied to the pixels of the 2.21:1 picture to be displayed on a 4:3 monitor. Up sampling from 2.21:1 pictures for display on a 4:3 monitor is optional in the IRD.			
NOTE 4: The up sampling with this value is applied to the pixels of the 2.21:1 picture to be displayed on a 16:9 monitor. Up sampling from 2.21:1 pictures for display on a 16:9 monitor is optional in the IRD.			
NOTE 5: It is recommended that luminance resolution of 704 pixels represents the "middle" of the picture, and that it be decoded to a 720 pixels full-screen display by placing 8 pixels of padding at each side. It is recommended that luminance resolutions, such as 352 pixels, that are natural scalings of 704 pixels, be upscaled to 704 pixels and padded as above. It is recommended that all other resolutions be scaled as indicated by the table above. Where this does not result in the expected 720 pixels full-screen display, it is recommended that the result of the scaling be clipped or padded symmetrically as required to produce a 720 pixels full-screen display.			

5.1.5 Chromaticity Parameters

Encoding: It is recommended that the chromaticity co-ordinates of the ideal display, opto-electronic transfer characteristic of the ideal display and matrix coefficients used in deriving luminance and chrominance signals from the red, green and blue primaries be explicitly signalled in the encoded bitstream by setting the appropriate values for each of the following 3 parameters in the **sequence_display_extension()**: **colour_primaries**, **transfer_characteristics**, and **matrix_coefficients**.

Within 25 Hz MPEG-2 SDTV bitstreams, if the *sequence_display_extension()* is not present in the bitstream or *colour_description* is zero, the chromaticity shall be implicitly defined to be that corresponding to *colour primaries* having the value 5, the transfer characteristics shall be implicitly defined to be those corresponding to *transfer characteristics* having the value 5 and the matrix coefficients shall be implicitly defined to be those corresponding *matrix coefficients* having the value 5. This set of parameter values corresponds signals compliance with ITU-R Recommendation BT. 1700, Part B [25].

NOTE: Previous editions of the present document referenced ITU-R Recommendation BT.470 [i.4] System B, G, I colorimetry. ITU-R Recommendation BT.1700 [25] replaces ITU-R Recommendation BT. 470 [i.4].

5.1.6 Chrominance

Encoding: *The operation used to down sample the chrominance information from 4:2:2 to 4:2:0 shall be indicated by the parameter **chroma_420_type** in the picture coding extension. A value of zero indicates that the fields have been down sampled independently. A value of one indicates that the two fields have been combined into a single frame before down sampling. It is desirable that the fields are down sampled independently (i.e. **chroma_420_type** = 0) to allow the IRD to use less memory for picture reconstruction.*

Decoding: *It is desirable that the operation used to up sample the chrominance information from 4:2:0 to 4:2:2 should be dependent on the parameter **chroma_420_type** in the picture coding extension.*

5.1.7 Video sequence header

Encoding: *It is recommended that a video sequence header, immediately followed by an I-frame, be encoded at least once every 500 ms. If quantizer matrices other than the default are used, the appropriate **intra_quantizer_matrix** and/or **non_intra_quantizer_matrix** are recommended to be included in every sequence header.*

NOTE 1: Increasing the frequency of video sequence headers and I-frames will reduce channel hopping time but will reduce the efficiency of the video compression.

NOTE 2: Having a regular interval between I-frames may improve trick mode performance, but may reduce the efficiency of the video compression.

5.2 25 Hz MPEG-2 HDTV IRDs and Bitstreams

The video encoding shall conform to ITU-T Recommendation H.262 / ISO/IEC 13818-2 [2]. Some of the parameters and fields are not used in the DVB System and these restrictions are described below. The IRD design shall be made under the assumption that any legal structure as permitted by ITU-T Recommendation H.262 / ISO/IEC 13818-2 [2] may occur in the broadcast stream even if presently reserved or unused.

5.2.1 Profile and level

Encoding: *Encoded 25 Hz MPEG-2 HDTV bitstreams shall comply with the Main Profile High Level restrictions, as described in ITU-T Recommendation H.262 / ISO/IEC 13818-2 [2], clause 8.2. The **profile_and_level_indication** is "01000100" or, if appropriate, "0nnnnnnn", where "0nnnnnnn">"01000100", indicating a "simpler" profile or level than Main Profile, High Level.*

Decoding: *The 25 Hz MPEG-2 HDTV IRD shall support the decoding of Main Profile High Level bitstreams. This requirement includes support for "simpler" profiles and levels, including Main Profile at Main Level, as defined in table 8-15 of ITU-T Recommendation H.262 / ISO/IEC 13818-2 [2]. Support for profiles and levels beyond Main Profile, High Level is optional. If the IRD encounters an extension which it cannot decode, such as one whose identification code is Reserved, Picture Sequence Scaleable, Picture Spatial Scaleable or Picture Temporal Scaleable, it shall discard the following data until the next start code (to allow backward compatible extensions to be added in the future).*

5.2.2 Frame rate

Encoding: *The frame rate shall be 25 Hz or 50 Hz, i.e. **frame_rate_code** is "0011" or "0110".*

The source video format for 50 Hz frame rate material shall be progressive. The source video format for 25 Hz frame rate material may be interlaced or progressive.

Still pictures may be encoded by use of a video sequence consisting of a single intra-coded picture (see definition of still pictures in ITU-T Recommendation H.222.0 / ISO/IEC 13818-1 [1], clause 2.1.70).

Decoding: *All 25 Hz MPEG-2 HDTV IRDs shall support the decoding and display of video material with a frame rate of 25 Hz progressive, 25 Hz interlaced or 50 Hz progressive (i.e. **frame_rate_code** of "0011" or "0110") within the constraints of Main Profile at High Level. Support of other frame and field rates is optional.*

25 Hz MPEG-2 HDTV IRDs shall be capable of decoding and displaying still pictures, i.e. video sequences consisting of a single intra-coded picture (see definition of still pictures in ITU-T Recommendation H.222.0 / ISO/IEC 13818-1 [1], clause 2.1.70).

5.2.3 Aspect ratio

Encoding: *The source aspect ratio in 25 Hz MPEG-2 HDTV bitstreams shall be 16:9 or 2.21:1. Note that decoding of 2.21:1 aspect ratio is optional for the 25 Hz MPEG-2 HDTV IRD.*

*The **aspect_ratio_information** in the sequence header shall have the value "0011" or "0100".*

Decoding: *The 25 Hz MPEG-2 HDTV IRD shall be able to decode bitstreams with **aspect_ratio_information** of value "0011", corresponding to 16:9 aspect ratio. The support of the aspect ratio 2.21:1 is optional. If the IRD has a digital interface, this should be capable of outputting bitstreams with aspect ratios which are not directly supported by the IRD to allow their decoding and display via an external unit.*

5.2.4 Luminance resolution

Encoding: *The encoded picture shall have a full-screen luminance resolution within the constraints set by Main Profile at High Level, i.e. it shall not have more than:*

- 1 088 lines per frame;
- 1 920 luminance samples per line;
- 62 668 800 luminance samples per second.

It is recommended that the source video for 25 Hz MPEG-2 HDTV Bitstreams has a luminance resolution of:

- 1 080 lines per frame;
- 1 920 luminance samples per line;
- with an associated frame rate of 25 Hz, with two interlaced fields per frame.

The source video may or may not be down-sampled prior to encoding.

The use of other encoded video resolutions within the constraints of Main Profile at High Level is also permitted. Annex A of the present document provides examples of supported full-screen luminance resolutions. In addition, non full-screen pictures may be encoded for display at less than full-size.

NOTE 1: The limit of 62 668 800 luminance samples per second of Main Profile at High Level excludes the use of the maximum allowed picture resolution at 50 Hz frame rate.

NOTE 2: If the recommended source video format is encoded without down-sampling it gives 51 840 000 luminance samples per second and therefore falls within the allowed range for Main Profile at High Level.

Decoding: *The 25 Hz MPEG-2 HDTV IRD shall be capable of decoding and displaying pictures with luminance resolutions within the constraints set by Main Profile at High Level.*

5.2.5 Chromaticity Parameters

Encoding: *The chromaticity co-ordinates of the ideal display, opto-electronic transfer characteristic of the source picture and matrix coefficients used in deriving luminance and chrominance signals from the red, green and blue primaries shall be explicitly signalled in the encoded HDTV bitstream by setting the appropriate values for each of the following 3 parameters in the `sequence_display_extension()`: **colour_primaries**, **transfer_characteristics**, and **matrix_coefficients**.*

It is recommended that 25 Hz MPEG-2 HDTV bitstreams use either ITU-R Recommendation BT.709 [13] or IEC 61966-2-4 [31] colorimetry.

BT.709 [13] colorimetry usage is signalled by setting **colour_primaries** to the value 1, **transfer_characteristics** to the value 1 and **matrix_coefficients** to the value 1.

IEC 61966-2-4 [31] colorimetry usage is signalled by setting **colour_primaries** to the value 1, **transfer_characteristics** to the value 11 and **matrix_coefficients** to the value 1.

Decoding: *The 25 Hz MPEG-2 HDTV IRD shall be capable of decoding bitstreams that use ITU-R Recommendation BT.709 [13] colorimetry. It is recommended that appropriate processing be included for the accurate representation of pictures using ITU-R Recommendation BT.709 [13] colorimetry.*

The 25 Hz MPEG-2 HDTV IRD may be capable of decoding bitstreams that use IEC 61966-2-4 [31] colorimetry.

NOTE 1: The 25Hz MPEG-2 HDTV IRD may not include appropriate processing for the accurate representation of pictures that use IEC 61966-2-4 [31] colorimetry.

NOTE 2: For the 50 Hz 576P video format the colorimetry standard recommended is ITU-R Recommendation BT.1358 [i.5].

5.2.6 Chrominance

Encoding: *The operation used to down sample the chrominance information from 4:2:2 to 4:2:0 shall be indicated by the parameter **chroma_420_type** in the picture coding extension. A value of zero indicates that the fields have been down sampled independently. A value of one indicates that the two fields have been combined into a single frame before down sampling. It is desirable that the fields are down sampled independently (i.e. **chroma_420_type** = 0) to allow the IRD to use less memory for picture reconstruction.*

Decoding: It is desirable that the operation used to up sample the chrominance information from 4:2:0 to 4:2:2 should be dependent on the parameter **chroma_420_type** in the picture coding extension.

5.2.7 Video sequence header

Encoding: It is recommended that a video sequence header, immediately followed by an I-frame, be encoded at least once every 500 ms. If quantizer matrices other than the default are used, the appropriate **intra_quantizer_matrix** and/or **non_intra_quantizer_matrix** are recommended to be included in every sequence header.

NOTE 1: Increasing the frequency of video sequence headers and I-frames will reduce channel hopping time but will reduce the efficiency of the video compression.

NOTE 2: Having a regular interval between I-frames may improve trick mode performance, but may reduce the efficiency of the video compression.

5.2.8 Backwards Compatibility

Decoding: *In addition to the above, a 25 Hz MPEG-2 HDTV IRD shall be capable of decoding any bitstream that a 25 Hz MPEG-2 SDTV IRD is required to decode, as described in clause 5.1.*

5.3 30 Hz MPEG-2 SDTV IRDs and Bitstreams

The video encoding shall conform to ITU-T Recommendation H.262 / ISO/IEC 13818-2 [2]. Some of the parameters and fields are not used in the DVB System and these restrictions are described below. The IRD design shall be made under the assumption that any legal structure as permitted by ITU-T Recommendation H.262 / ISO/IEC 13818-2 [2] may occur in the broadcast stream even if presently reserved or unused.

5.3.1 Profile and level

Encoding: *Encoded bitstreams shall comply with the Main Profile Main Level restrictions, as described in ITU-T Recommendation H.262 / ISO/IEC 13818-2 [2], clause 8.2. The **profile_and_level_indication** is "01001000" or, if appropriate, "0nnnnnnn", where "0nnnnnnn">"01001000", indicating a "simpler" profile or level than Main Profile, Main Level.*

Decoding: *The IRD shall support the syntax of Main Profile. Support for profiles and levels beyond Main Profile, Main Level is optional. If the IRD encounters an extension which it cannot decode, such as one whose identification code is Reserved, Picture Sequence Scaleable, Picture Spatial Scaleable or Picture Temporal Scaleable, it shall discard the following data until the next start code (to allow backward compatible extensions to be added in the future).*

5.3.2 Frame rate

Encoding: *The frame rate shall be either 24 000/1 001, 24, 30 000/1 001 or 30 Hz, i.e. the **frame_rate_code** field shall be encoded with one of the following values: "0001", "0010", "0100" or "0101".*

Still pictures may be encoded by use of a video sequence consisting of a single intra-coded picture (see definition of still pictures in ITU-T Recommendation H.222.0 / ISO/IEC 13818-1 [1], clause 2.1.70).

Decoding: *All 30 Hz SDTV IRDs shall support the decoding and display of Main Profile @ Main Level video with a frame rate of 24 000/1 001, 24, 30 000/1 001 or 30 Hz. Support of other frame rates is optional.*

IRDs shall be capable of decoding and displaying still pictures, i.e. video sequences consisting of a single intra-coded picture (see definition of still pictures in ITU-T Recommendation H.222.0 / ISO/IEC 13818-1 [1], clause 2.1.70).

5.3.3 Aspect ratio

Encoding: *The source aspect ratio in 30 Hz MPEG-2 SDTV bitstreams shall be either 4:3, 16:9 or 2.21:1. Note that decoding of 2.21:1 aspect ratio is optional for the 30 Hz SDTV IRD.*

*The **aspect_ratio_information** in the sequence header shall have one of the following three values:*

- 4:3 aspect ratio source: "0010";
- 16:9 aspect ratio source: "0011";
- 2.21:1 aspect ratio source: "0100".

It is recommended that pan vectors for a 4:3 window are included in the transmitted bitstream when the source aspect ratio is 16:9 or 2.21:1. The vertical component of the transmitted pan vector shall be zero.

If pan vectors are transmitted then the **sequence_display_extension** shall be present in the bitstream and the **aspect_ratio_information** shall be set to '0010' (4:3 display). The **display_vertical_size** shall be equal to the **vertical_size**. The **display_horizontal_size** shall contain the resolution of the target 4:3 display. The value of the **display_horizontal_size** field may be calculated by the following equation:

$$\text{display_horizontal_size} = \frac{4}{3} \times \frac{\text{horizontal_size}}{\text{source aspect ratio}}$$

Table 5 gives some typical examples.

Table 5: Values for display_horizontal_size

horizontal_size × vertical_size	Source aspect ratio	Display_horizontal_size
720 × 480	16:9	540
640 × 480	16:9	480
544 × 480	16:9	408
480 × 480	16:9	360
352 × 480	16:9	264
352 × 240	16:9	264

Decoding: *The 30 Hz MPEG-2 SDTV IRD shall be able to decode bitstreams with values of **aspect_ratio_information** of "0010" and "0011", corresponding to 4:3 and 16:9 aspect ratio respectively. If the IRD has a digital interface, this should be capable of outputting bitstreams with aspect ratios which are not directly supported by the IRD to allow their decoding and display via an external unit.*

All 30 Hz MPEG-2 SDTV IRDs shall support the use of pan vectors and up sampling to allow a 4:3 monitor to give a full-screen display of a selected portion of a 16:9 coded picture with the correct aspect ratio. IRDs implementing the 2.21:1 aspect ratio should support the use of pan vectors and up sampling to allow a 4:3 monitor to give a full-screen display of a selected portion of the 2.21:1 picture with the correct aspect ratio. Support for pan vectors with non-zero vertical components is optional. When no pan vectors are present in the transmitted bitstream, the central portion of the wide-screen picture shall be displayed. The support of vertical resampling to obtain the correct aspect ratio for a letterbox display of a 16:9 or 2.21:1 coded picture on a 4:3 monitor is optional.

5.3.4 Luminance resolution

Encoding: *The encoded picture shall have a full-screen luminance resolution (horizontal × vertical) of one of the following values:*

- 720 × 480;
- 640 × 480;
- 544 × 480;
- 480 × 480;
- 352 × 480;
- 352 × 240.

In addition, non full-screen pictures may be encoded for display at less than full-size (when using one of the standard up-conversion ratios at the IRD).

Decoding: *The 30 Hz MPEG-2 SDTV IRD shall be capable of decoding pictures with luminance resolutions as shown in table 6 and applying up sampling to allow the decoded pictures to be displayed at full-screen size. In addition, IRDs shall be capable of decoding lower picture resolutions and displaying them at less than full-size after using one of the standard up-conversions, e.g. a horizontal resolution of 704 pixels within the 720 pixels full-screen display.*

Table 6: Resolutions for Full-screen Display from 30 Hz MPEG-2 SDTV IRD

Coded Picture		Displayed Picture Horizontal up sampling	
Luminance resolution (horizontal × vertical)	Aspect Ratio	4:3 Monitors	16:9 Monitors
720 × 480	4:3 16:9 2:21:1	× 1 × 4/3 (see note 2) × 5/3 (see note 3)	× 3/4 (see note 1) × 1 × 5/4 (see note 4)
640 × 480	4:3	× 9/8	× 27/32 (see note 1)
544 × 480	4:3 16:9 2:21:1	× 4/3 × 16/9 (see note 2) × 20/9 (see note 3)	× 1 (see note 1) × 4/3 × 5/3 (see note 4)
480 × 480	4:3 16:9 2:21:1	× 3/2 × 2 (see note 2) × 5/2 (see note 3)	× 9/8 (see note 1) × 3/2 × 15/8 (see note 4)
352 × 480	4:3 16:9 2:21:1	× 2 × 8/3 (see note 2) × 10/3 (see note 3)	× 3/2 (see note 1) × 2 × 5/2 (see note 4)
352 × 240	4:3 16:9 2:21:1	× 2 × 8/3 (see note 2) × 10/3 (see note 3) (and vertical up sampling × 2)	× 3/2 (see note 1) × 2 × 5/2 (see note 4) (and vertical up sampling × 2)

NOTE 1: Up sampling of 4:3 pictures for display on a 16:9 monitor is optional in the IRD, as 16:9 monitors can be switched to operate in 4:3 mode.

NOTE 2: The up sampling with this value is applied to the pixels of the 16:9 picture to be displayed on a 4:3 monitor.

NOTE 3: The up sampling with this value is applied to the pixels of the 2.21:1 picture to be displayed on a 4:3 monitor. Up sampling from 2.21:1 pictures for display on a 4:3 monitor is optional in the IRD.

NOTE 4: The up sampling with this value is applied to the pixels of the 2.21:1 picture to be displayed on a 16:9 monitor. Up sampling from 2.21:1 pictures for display on a 16:9 monitor is optional in the IRD.

NOTE 5: It is recommended that luminance resolution of 704 pixels represents the "middle" of the picture, and that it be decoded to a 720 pixels full-screen display by placing 8 pixels of padding at each side. It is recommended that luminance resolutions, such as 352 pixels, that are natural scalings of 704 pixels, be upsampled to 704 pixels and padded as above. It is recommended that all other resolutions be scaled as indicated by the table above. Where this does not result in the expected 720 pixels full-screen display, it is recommended that the result of the scaling be clipped or padded symmetrically as required to produce a 720 pixels full-screen display.

5.3.5 Chromaticity Parameters

Encoding: It is recommended that the chromaticity co-ordinates of the ideal display, opto-electronic transfer characteristic of the ideal display and matrix coefficients used in deriving luminance and chrominance signals from the red, green and blue primaries be explicitly signalled in the encoded bitstream by setting the appropriate values for each of the following 3 parameters in the **sequence_display_extension()**: **colour_primaries**, **transfer_characteristics**, and **matrix_coefficients**.

*Within 30 Hz SDTV bitstreams, if the **sequence_display_extension()** is not present in the bitstream or **colour_description** is zero, the chromaticity shall be implicitly defined to be that corresponding to **colour_primaries** having the value 6, the transfer characteristics shall be implicitly defined to be those corresponding to **transfer_characteristics** having the value 6 and the matrix coefficients shall be implicitly defined to be those corresponding **matrix_coefficients** having the value 6. This set of parameter values signals compliance with ITU-R Recommendation BT.1700 Part A [25].*

NOTE: Previous editions of the present document referenced SMPTE ST 170 colorimetry [i.9]. ITU-R Recommendation BT.1700 Part A [25] references SMPTE ST 170.

5.3.6 Chrominance

Encoding: *The operation used to down sample the chrominance information from 4:2:2 to 4:2:0 shall be indicated by the parameter **chroma_420_type** in the picture coding extension. A value of zero indicates that the fields have been down sampled independently. A value of one indicates that the two fields have been combined into a single frame before down sampling. It is desirable that the fields are down sampled independently (i.e. **chroma_420_type** = 0) to allow the IRD to use less memory for picture reconstruction.*

Decoding: *It is desirable that the operation used to up sample the chrominance information from 4:2:0 to 4:2:2 should be dependent on the parameter **chroma_420_type** in the picture coding extension.*

5.3.7 Video sequence header

Encoding: *It is recommended that a video sequence header, immediately followed by an I-frame, be encoded at least once every 500 ms. If quantizer matrices other than the default are used, the appropriate **intra_quantizer_matrix** and/or **non_intra_quantizer_matrix** are recommended to be included in every sequence header.*

NOTE 1: *Increasing the frequency of video sequence headers and I-frames will reduce channel hopping time but will reduce the efficiency of the video compression.*

NOTE 2: *Having a regular interval between I-frames may improve trick mode performance, but may reduce the efficiency of the video compression.*

5.4 30 Hz MPEG-2 HDTV IRDs and Bitstreams

The video encoding shall conform to ITU-T Recommendation H.262 / ISO/IEC 13818-2 [2]. Some of the parameters and fields are not used in the DVB System and these restrictions are described below. The IRD design shall be made under the assumption that any legal structure as permitted by ITU-T Recommendation H.262 / ISO/IEC 13818-2 [2] may occur in the broadcast stream even if presently reserved or unused.

5.4.1 Profile and level

Encoding: *Encoded 30 Hz MPEG-2 HDTV bitstreams shall comply with the Main Profile High Level restrictions, as described in ITU-T Recommendation H.262 / ISO/IEC 13818-2 [2], clause 8.2.*

*The **profile_and_level_indication** is "01000100" or, if appropriate, "0nnnnnnn", where "0nnnnnnn">"01000100", indicating a "simpler" profile or level than Main Profile, High Level.*

Decoding: *The 30 Hz MPEG-2 HDTV IRD shall support the decoding of Main Profile High Level bitstreams. This requirement includes support for "simpler" profiles and levels, including Main Profile at Main Level, as defined in table 8-15 of ITU-T Recommendation H.262 / ISO/IEC 13818-2 [2]. Support for profiles and levels beyond Main Profile, High Level is optional. If the IRD encounters an extension which it cannot decode, such as one whose identification code is Reserved, Picture Sequence Scaleable, Picture Spatial Scaleable or Picture Temporal Scaleable, it shall discard the following data until the next start code (to allow backward compatible extensions to be added in the future).*

5.4.2 Frame rate

Encoding: *The frame rate shall be 24 000/1 001, 24, 30 000/1 001, 30, 60 000/1 001 or 60 Hz, i.e. **frame_rate_code** is "0001", "0010", "0100", "0101", "0111" or "1000".*

The source video format for 24 000/1 001, 24, 60 000/1 001 and 60 Hz frame rate material shall be progressive. The source video format for 30 000/1 001 and 30 Hz frame rate material may be interlaced or progressive.

Still pictures may be encoded by use of a video sequence consisting of a single intra-coded picture (see definition of still pictures in ITU-T Recommendation H.222.0 / ISO/IEC 13818-1 [1], clause 2.1.70).

Decoding: *All 30 Hz MPEG-2 HDTV IRDs shall support the decoding of video material with a frame rate of 24 000/1 001, 24, 30 000/1 001, 30, 60 000/1 001 or 60 Hz (i.e. **frame_rate_code** of "0001", "0010", "0100", "0101", "0111" or "1000") within the constraints of Main Profile at High Level. Support of other frame rates is optional.*

30 Hz MPEG-2 HDTV IRDs shall support the display of video whose source frame rate is 24 000/1 001, 24, 30 000/1 001, 30, 60 000/1 001 or 60 Hz progressive. 30 Hz MPEG-2 HDTV IRDs shall support the display of video whose source frame rate is 30 000/1 001 or 30 Hz interlaced.

30 Hz MPEG-2 HDTV IRDs shall be capable of decoding and displaying still pictures, i.e. video sequences consisting of a single intra-coded picture (see definition of still pictures in ITU-T Recommendation H.222.0 / ISO/IEC 13818-1 [1], clause 2.1.70).

5.4.3 Aspect ratio

Encoding: *The source aspect ratio in 30 Hz MPEG-2 HDTV bitstreams shall be 16:9 or 2.21:1. Note that decoding of 2.21:1 aspect ratio is optional for the 30 Hz MPEG-2 HDTV IRD.*

*The **aspect_ratio_information** field in the sequence header shall have the value "0011" or "0100".*

Decoding: *The 30 Hz MPEG-2 HDTV IRD shall be able to decode bitstreams with **aspect_ratio_information** of value "0011", corresponding to 16:9 aspect ratio. If the IRD has a digital interface, this should be capable of outputting bitstreams with aspect ratios which are not directly supported by the IRD to allow their decoding and display via an external unit.*

5.4.4 Luminance resolution

Encoding: *The encoded picture shall have a full-screen luminance resolution within the constraints set by Main Profile at High Level, i.e. it shall not have more than:*

- 1 088 lines per frame;
- 1 920 luminance samples per line;
- 62 668 800 luminance samples per second.

It is recommended that the source video for 30 Hz MPEG-2 HDTV Bitstreams has a luminance resolution of:

- 1 080 lines per frame and 1 920 luminance samples per line, with an associated frame rate of 30 000/1 001 (approximately 29,97) Hz with two interlaced fields per frame.
- The source video may or may not be down-sampled prior to encoding.
- The use of other encoded video resolutions within the constraints of Main Profile at High Level is also permitted. Annex A of the present document provides examples of supported full-screen luminance resolutions. In addition, non full-screen pictures may be encoded for display at less than full-size.
- The limit of 62 668 800 luminance samples per second of Main Profile at High Level excludes the use of the maximum allowed picture resolution at 60 Hz and 60 000/1 001 frame rates.

NOTE: If the recommended source video format is encoded without down-sampling it gives 62 145 854 luminance sample per second and therefore falls within the allowed range for Main Profile at High Level.

Decoding: *The 30 Hz MPEG-2 HDTV IRD shall be capable of decoding and displaying pictures with luminance resolutions within the constraints set by Main Profile at High Level.*

5.4.5 Chromaticity Parameters

Encoding: *The chromaticity co-ordinates of the ideal display, opto-electronic transfer characteristic of the source picture and matrix coefficients used in deriving luminance and chrominance signals from the red, green and blue primaries shall be explicitly signalled in the encoded HDTV bitstream by setting the appropriate values for each of the following 3 parameters in the `sequence_display_extension()`: **colour_primaries**, **transfer_characteristics**, and **matrix_coefficients**.*

It is recommended that 30 Hz MPEG-2 HDTV bitstreams use either ITU-R Recommendation BT.709 [13] or IEC 61966-2-4 [31] colorimetry.

BT.709 [13] colorimetry usage is signalled by setting **colour_primaries** to the value 1, **transfer_characteristics** to the value 1 and **matrix_coefficients** to the value 1.

IEC 61966-2-4 [31] colorimetry usage is signalled by setting **colour_primaries** to the value 1, **transfer_characteristics** to the value 11 and **matrix_coefficients** to the value 1.

Decoding: *The 30 Hz MPEG-2 HDTV IRD shall be capable of decoding bitstreams that use ITU-R Recommendation BT.709 [13] colorimetry. It is recommended that appropriate processing be included for the accurate representation of pictures using ITU-R Recommendation BT.709 [13] colorimetry.*

The 30 Hz MPEG-2 HDTV IRD may be capable of decoding bitstreams that use IEC 61966-2-4 [31] colorimetry.

NOTE 1: The 30Hz MPEG-2 HDTV IRD may not include appropriate processing for the accurate representation of pictures that use IEC 61966-2-4 [31] colorimetry.

NOTE 2: For the 60 000/1 001 or 60 Hz 480P video format the colorimetry standard recommended is ITU-R Recommendation BT.1358 [i.5].

5.4.6 Chrominance

Encoding: *The operation used to down sample the chrominance information from 4:2:2 to 4:2:0 shall be indicated by the parameter **chroma_420_type** in the picture coding extension. A value of zero indicates that the fields have been down sampled independently. A value of one indicates that the two fields have been combined into a single frame before down sampling. It is desirable that the fields are down sampled independently (i.e. **chroma_420_type** = 0) to allow the IRD to use less memory for picture reconstruction.*

Decoding: It is desirable that the operation used to up sample the chrominance information from 4:2:0 to 4:2:2 should be dependent on the parameter **chroma_420_type** in the picture coding extension.

5.4.7 Video sequence header

Encoding: It is recommended that a video sequence header, immediately followed by an I-frame, be encoded at least once every 500 ms. If quantizer matrices other than the default are used, the appropriate **intra_quantizer_matrix** and/or **non_intra_quantizer_matrix** are recommended to be included in every sequence header.

NOTE 1: Increasing the frequency of video sequence headers and I-frames will reduce channel hopping time but will reduce the efficiency of the video compression.

NOTE 2: Having a regular interval between I-frames may improve trick mode performance, but may reduce the efficiency of the video compression.

5.4.8 Backwards Compatibility

Decoding: *In addition to the above, a 30 Hz MPEG-2 HDTV IRD shall be capable of decoding any bitstream that a 30 Hz MPEG-2 SDTV IRD is required to decode, as described in clause 5.3.*

5.5 Specifications Common to all H.264/AVC IRDs and Bitstreams

The specification in this clause applies to the following IRDs and Bitstreams:

- 25 Hz H.264/AVC SDTV IRD and Bitstream;
- 30 Hz H.264/AVC SDTV IRD and Bitstream;
- 25 Hz H.264/AVC HDTV IRD and Bitstream;
- 30 Hz H.264/AVC HDTV IRD and Bitstream;
- 50 Hz H.264/AVC HDTV IRD and Bitstream;
- 60 Hz H.264/AVC HDTV IRD and Bitstream;
- 25 Hz MVC Stereo HDTV IRD and Bitstream;
- 30 Hz MVC Stereo HDTV IRD and Bitstream.

5.5.1 General

The video encoding and video decoding shall conform to ITU-T Recommendation H.264 / ISO/IEC 14496-10 [16]. Some of the parameters and fields are not used in the DVB System and these restrictions are described below. H.264/AVC Bitstreams and IRDs shall support some parts of the "Supplemental Enhancement Information (SEI)" and the "Video usability information (VUI)" syntax elements as specified in ITU-T Recommendation H.264 / ISO/IEC 14496-10 Annexes D and E [16]. The H.264/AVC IRD design shall be made under the assumption that any legal structure as permitted by ITU-T Recommendation H.264 / ISO/IEC 14496-10 [16] and the restrictions that are specified for the H.264/AVC IRDs may occur in the broadcast stream even if presently reserved or unused.

NOTE: To improve trick mode it is strongly recommended to disable non-paired fields in H.264/AVC Encoder.

5.5.2 Sequence Parameter Set and Picture Parameter Set

Encoding: More than one picture parameter set can be present in the bitstream between two H.264/AVC RAPs. *Between two H.264/AVC RAPs, the content of a picture parameter set with a particular **pic_parameter_set_id** shall not change.* I.e. if more than one picture parameter set is present in the bitstream and these picture parameter sets are different from each other, then each picture parameter set shall have a different **pic_parameter_set_id**.

Note that multiple PPSs may be present in the H.264/AVC RAP access unit and the number of PPS that may be present is constrained by clause 4.1.5.2 where the start of the access unit (**access_unit_delimiter**) and the start of the first slice of the access unit must occur either in the same transport packet or in 2 successive transport packets.

5.5.2.1 **pic_width_in_mbs_minus1** and **pic_height_in_map_units_minus1**

Encoding: *The time interval between two changes in pairs of **pic_width_in_mbs_minus1** and **pic_height_in_map_units_minus1** shall be greater than or equal to one second.* Changing the pair **pic_width_in_mbs_minus1** and **pic_height_in_map_units_minus1** requires software processing in the decoder. Limiting the frequency of this change is to constrain the IRD software processing required to support aspect ratio changes.

NOTE: A pair of **pic_width_in_mbs_minus1** and **pic_height_in_map_units_minus1** is distinct from another pair if one or both syntax element values **pic_width_in_mbs_minus1** and **pic_height_in_map_units_minus1** differ.

If the number of samples per row of the luminance component of the source picture is not an integer multiple of 16 and additional samples are padded to make the number of samples per row of the luminance component an integer multiple of 16, it is recommended that these samples are padded at the right side of the picture.

If the number of samples per column of the luminance component of the source picture is not an integer multiple of 16 and additional samples are padded to make the number of samples per column of the luminance component an integer multiple of 16, it is recommended that these samples are padded at the bottom of the picture.

5.5.3 Video Usability Information

The IRD shall support the use of Video Usability Information of the following syntax elements:

- Aspect Ratio Information (*aspect_ratio_idc*);
- Colour Parameter Information (*colour_primaries*, *transfer_characteristics*, and *matrix_coefficients*);
- Chrominance Information (*chroma_sample_loc_type_top_field* and *chroma_sample_loc_type_bottom_field*);
- Timing information (*time_scale*, *num_units_in_tick*, and *fixed_frame_rate_flag*);
- Picture Structure Information (*pic_struct_present_flag*).

5.5.3.1 Aspect Ratio Information

The support of **aspect_ratio_idc** values for H.264/AVC SDTV IRDs and Bitstreams is specified in clause 5.6.1.3 and for H.264/AVC HDTV IRDs and Bitstreams is specified in clause 5.7.1.2 and for MVC in clause 5.13.1.6.2.

5.5.3.2 Colour Parameter Information

The support of **colour_primaries**, **transfer_characteristics**, and **matrix_coefficients** values for the 25 Hz H.264/AVC SDTV IRD and Bitstream is specified in clause 5.6.2.1, for the 30 Hz H.264/AVC SDTV IRD and Bitstream is specified in clause 5.6.3.1, and for H.264/AVC HDTV IRDs and Bitstreams is specified in clause 5.7.1.3 and for MVC Stereo HDTV IRDs in clause 5.13.1.6.2.

5.5.3.3 Chrominance Information

Encoding: It is recommended to specify the chrominance locations using the syntax elements **chroma_sample_loc_type_top_field** and **chroma_sample_loc_type_bottom_field** in the VUI. It is recommended to use chroma sample type equal to 0 for both fields.

Decoding: *H.264/AVC IRDs shall support decoding any allowed values of **chroma_sample_loc_type_top_field** and **chroma_sample_loc_type_bottom_field**. It is recommended that appropriate processing be included for the display of pictures.*

5.5.3.4 Timing Information

The support of **time_scale** and **num_units_in_tick** values for the 25 Hz H.264/AVC SDTV IRD and Bitstream is specified in clause 5.6.2.2, for the 30 Hz H.264/AVC SDTV IRD and Bitstream is specified in clause 5.6.3.2, for the 25 Hz H.264/AVC HDTV IRD and Bitstream is specified in clause 5.7.2.2, for the 30 Hz H.264/AVC HDTV IRD and Bitstream is specified in clause 5.7.3.2, for the 50 Hz H.264/AVC HDTV IRD and Bitstream is specified in clause 5.7.4.2, for the 60 Hz H.264/AVC HDTV IRD and Bitstream is specified in clause 5.7.5.2, for the 25 Hz MVC Stereo HDTV IRD and Bitstream in clause 5.13.2.2 and for the 25 Hz MVC Stereo HDTV IRD and Bitstream in clause 5.13.3.2. *In the case of still picture the **fixed_frame_rate_flag** shall be equal to 0. In other cases, the **fixed_frame_rate_flag** shall be equal to 1.* The frame rate can not be changed between two IDR access units.

5.5.3.5 Picture Structure Information

The support of **pic_struct_present_flag** in the Bitstream is specified in clause 5.5.4.1 related to use of Picture Structure information in the Picture Timing SEI and is common to all H.264/AVC IRDs and Bitstreams. For bitstreams that carry the picture structure information (such as film mode), it is recommended that the **pic_struct_present_flag** be set to "1" in the VUI and the picture timing SEI is associated with each access unit in the coded sequence. If the sequence does not require picture structure information, then the **pic_struct_present_flag** should be set to "0" in the VUI. Use of this flag bit in the VUI allows use of picture timing SEI with only the picture structure information without the need to include HRD information (such as CPB and DPB delay or initial values of the delay in the buffering period SEI).

5.5.4 Supplemental Enhancement Information

The IRD shall support the use of Supplemental Enhancement Information of the following message types:

- Picture Timing SEI Message;
- Pan-Scan Rectangle SEI Message;
- "User data registered by ITU-T Recommendation T.35 SEI message" syntactic element [19] **user_data_registered_itu_t_t35** as defined in clause B.7.

5.5.4.1 Picture Timing SEI Message

Encoding: It is recommended to transmit a picture timing SEI message for every access unit of a coded video sequence.

*If the H.264/AVC Bitstream contains picture structure information, then the **pic_struct_present_flag** shall be set to "1" in the VUI and a picture timing SEI message shall be associated with every access unit. Otherwise the **pic_struct_present_flag** shall be set to "0".*

NOTE 1: Setting **pic_struct_present_flag** to "1" indicates the presence of **pic_struct** that assists decoders in determining if the picture should be displayed as a frame or one or more fields. Possible values for **pic_struct** are defined in table D-1 of ITU-T Recommendation H.264 / ISO/IEC 14496-10 [16]. Progressive coded video sequences (with **frame_mbs_only** equal to 1) should only use **pic_struct** values of 0, 7, 8. Interlace coded video sequences (with **frame_mbs_only_flag** equal to 0) should only use **pic_struct** values of 1, 2, 3, 4, 5, 6.

It is recommended that bitstreams avoid mixing interlaced and progressive **pic_struct** values within a coded video sequence to allow decoders to maintain a consistent display.

Note that it is recommended to avoid using frame doubling or tripling modes when coding frames in MBAFF mode.

It is recommended that **ct_type** be explicitly transmitted to convey the original picture scan.

NOTE 2: Possible values for **ct_type** are defined in table D-2 of ITU-T Recommendation H.264 / ISO/IEC 14496-10 [16]. Setting **ct_type** to 2 may be used to indicate an unknown original picture scan. The **ct_type** field may change between progressive and interlaced within a sequence. Progressive **ct_types** values may be present within a coded video sequence with interlaced **pic_struct** values but it is recommended not to transmit interlaced **ct_type** values within a coded video sequence with progressive **pic_struct** values.

NOTE 3: The original picture scan can be quite useful for assisting operations such as deinterlacing and trick modes. Explicit transmission of the **ct_type** field is indicated when the **clock_timestamp_flag[i]** is set to 1.

- If a timecode is to be carried, it is recommended that the **full_timestamp_flag** is set to "1" and **hours_value**, **minutes_value**, **seconds_value** and **n_frames** are used to transport the timecode values. **Time_offset** may be ignored and normally carry the value "0", if present.

NOTE 4: The default value of **time_offset_length** is 24 unless specified otherwise by the VUI message HRD parameters, which in turn requires the presence of additional fields in the picture timing SEI message (**cpb_removal_delay** and **dpb_output_delay**).

Decoding: *H.264/AVC IRDs shall support all values defined in **pic_struct** including all modes requiring field and frame repetition.* The H.264/AVC IRDs need not make use of any other syntax elements (except **pic_struct**) in the picture timing SEI message, if these elements are present.

*If **ct_type** is not present, then the value "2" (unknown) shall be inferred.*

Note that if present, the picture structure information shall convey the picture output order in the same order as the Picture Order Count (POC) information in the H.264/AVC Bitstream (per clause D.2.2 of ITU-T Recommendation H.264 / ISO/IEC 14496-10 [16]). This ensures consistency between the SEI message and the HRD model of ITU-T Recommendation H.264 / ISO/IEC 14496-10 [16].

5.5.4.2 Pan-Scan Rectangle SEI Message

Encoding: The **pan_scan_rect** SEI may be used when appropriate.

Decoding: H.264/AVC IRDs shall support all values specified in **pan_scan_rect**, except **pan_scan_rect_top_offset[i]** and **pan_scan_rect_bottom_offset[i]**. The IRD need not make use of **pan_scan_rect_top_offset[i]** and **pan_scan_rect_bottom_offset[i]** parameters in the **pan_scan_rect** SEI message.

There may be more than one **pan_scan_rect** SEI message transmitted with an access unit. Any **pan_scan_rect** SEI messages after the first may be ignored.

The support of the use of **pan_scan_rect** for up sampling is specified to allow a 4:3 monitor to give a full-screen display of a selected portion of a 16:9 coded picture with the correct aspect ratio. The support of vertical resampling to obtain the correct aspect ratio for a letterbox display of a 16:9 coded picture on a 4:3 monitor is optional.

NOTE: Use of AFD as defined in clause B.3 and Bar Data as defined in clause B.4 may provide a more convenient mechanism for enabling the full screen display of a selected portion of the coded picture.

5.5.4.3 Still pictures

Encoding: Still pictures shall comply with "AVC still picture" definition as per ITU-T Recommendation H.222.0 / ISO/IEC 13818-1 [1]. For Still pictures the frame rate specification for H264 AVC IRDs shall not apply. The **fixed_frame_rate_flag** shall be equal to 0.

NOTE: For display that requires a fixed frame refresh according to the IRD frequency, the previously decoded picture should be displayed till the next picture is available.

5.5.5 Random Access Point

The definition for H.264/AVC RAP in clause 3 shall apply.

For MVC Stereo Bitstreams and MVC Stereo RAP guidelines, please refer to clause. 5.13.1.9.

Encoding: The time interval between H.264/AVC RAPs may vary between programs and also within a program. The broadcast requirements should set the time interval between H.264/AVC RAPs as specified in clause 5.5.5.1.

NOTE: The AU_information_descriptor described in annex D provides a means of signalling information about Random Access Points that may be used by some applications, and it is recommended that this is present.

All pictures with PTS greater than or equal to PTS(rap) shall be fully reconstructible and displayable, where PTS(rap) represents the Presentation Time Stamp of the picture of the H.264/AVC RAP. This means that decoders receiving the RAP shall not need to utilise data transmitted prior to the RAP to decode pictures displayed after the RAP.

To improve applications such as channel change, it is recommended that the Presentation Time Stamp of the picture of H.264/AVC RAP be less than or equal to [DTS(rap) + 0,5 seconds] where DTS(rap) represents the Decoding Time Stamp of the picture of H.264/AVC RAP.

Packetization of random access points shall comply with the following additional rule:

*A transport packet containing the PES header of a H.264/AVC RAP shall have an adaptation field. The **payload_unit_start_indicator** bit shall be set to "1" in the transport packet header and the **adaptation_field_control** bits shall be set to "11" (as per ITU-T Recommendation H.222.0 / ISO/IEC 13818-1 [1]). In addition, the **random_access_indicator** bit in the adaptation header shall be set to "1". The **elementary_stream_priority_indicator** bit shall also be set to "1" in the same adaptation header if this transport packet contains the slice start code of the H.264/AVC RAP access unit (see clauses 4.1.5.1 and 4.1.5.2).*

Decoding: *H.264/AVC IRDs shall be able to start decoding and displaying an H.264/AVC Bitstream at an H.264/AVC RAP.*

5.5.5.1 Time Interval Between RAPs

Encoding: *The encoder shall place H.264/AVC RAPs in the video elementary stream at least once every 5 s. It is recommended that H.264/AVC RAPs occur in the video elementary stream on average at least every 2 s. Where rapid channel change times are important or for applications such as PVR it may be appropriate for H.264/AVC RAPs to occur more frequently, such as every 500 ms. The time interval between successive RAPs shall be measured as the difference between their respective DTS values.*

NOTE 1: Decreasing the time interval between H.264/AVC RAPs may reduce channel hopping time and improve trick modes, but may reduce the efficiency of the video compression.

NOTE 2: Having a regular interval between H.264/AVC RAPs may improve trick mode performance, but may reduce the efficiency of the video compression.

5.6 H.264/AVC SDTV IRDs and Bitstreams

5.6.1 Specifications Common to all H.264/AVC SDTV IRDs and Bitstreams

The specification in this clause applies to the following IRDs and bitstreams:

- 25 Hz H.264/AVC SDTV IRD and Bitstream;
- 30 Hz H.264/AVC SDTV IRD and Bitstream.

5.6.1.1 Sequence Parameter Set and Picture Parameter Set

Encoding: *In addition to the provisions set forth in ITU-T Recommendation H.264 / ISO/IEC 14496-10 [16], the following restrictions apply for the fields in the sequence parameter set:*

profile_idc	= 77 (Main Profile)
profile_idc	= 100 when bitstream complies with High Profile. See clause 5.6.1.2 for details of when the bitstream may optionally comply with High Profile
constraint_set0_flag	= 0
constraint_set1_flag	= 1 (when profile_idc = 77) or = 0 (when profile_idc = 100)
constraint_set2_flag	= 0
constraint_set3_flag	= 0 (when profile_idc = 100)
gaps_in_frame_num_value_allowed_flag	= 0 (gaps not allowed)
vui_parameters_present_flag	= 1

5.6.1.2 Profile and level

Encoding: *H.264/AVC SDTV Bitstreams shall comply with Main Profile Level 3 restrictions, as described in ITU-T Recommendation H.264 / ISO/IEC 14496-10 [16]. In addition, in applications where decoders support the High Profile, the encoded bitstream may optionally comply with the High Profile.*

The value of level_idc shall be equal to 30.

Decoding: *H.264/AVC SDTV IRDs shall support decoding and displaying of Main Profile Level 3 bitstreams. Support of the High Profile and other profiles beyond Main Profile is optional. Support of levels beyond Level 3 is optional. If the H.264/AVC SDTV IRD encounters an extension which it cannot decode, it shall discard the following data until the next start code prefix (to allow backward compatible extensions to be added in the future).*

5.6.1.3 Aspect ratio

Encoding: *The source aspect ratio in H.264/AVC SDTV Bitstreams shall be either 4:3 or 16:9.*

The frame cropping information in the Sequence Parameter Set may be used when appropriate.

Decoding: *H.264/AVC SDTV IRDs shall support decoding and displaying H.264/AVC SDTV Bitstreams with the values of aspect_ratio_idc and other constraints that are specified in clause 5.6.2 for the 25 Hz H.264/AVC SDTV IRDs and Bitstreams and clause 5.6.3 for the 30 Hz H.264/AVC SDTV IRDs and Bitstreams.*

*The source aspect ratio information shall be derived from the **pic_height_in_map_units_minus1** and the **pic_width_in_mbs_minus1** and the frame cropping information coded in the Sequence Parameter Set as well as the sample aspect ratio encoded with the **aspect_ratio_idc** value in the Video Usability Information (see values of **aspect_ratio_idc** in ITU-T Recommendation H.264 / ISO/IEC 14496-10 [16], table E-1).*

H.264/AVC SDTV IRDs shall support frame cropping.

5.6.2 25 Hz H.264/AVC SDTV IRD and Bitstream

This clause specifies the 25 Hz H.264/AVC SDTV IRD and Bitstream. *All specifications in clauses 5.5 and 5.6.1 shall apply.* The specification in the remainder of this clause only applies to the 25 Hz H.264/AVC SDTV IRD and Bitstream.

5.6.2.1 Colour Parameter Information

Encoding: *The chromaticity co-ordinates of the ideal display, opto-electronic transfer characteristic of the source picture and matrix coefficients used in deriving luminance and chrominance signals from the red, green and blue primaries shall be explicitly signalled in the encoded 25 Hz H.264/AVC SDTV Bitstream by setting the appropriate values for each of the following 3 parameters in the VUI: **colour_primaries**, **transfer_characteristics**, and **matrix_coefficients**.*

It is recommended that ITU-R Recommendation BT.1700 Part B [25] colorimetry is used in the H.264/AVC Bitstream, which is signalled by setting **colour_primaries** to the value 5, **transfer_characteristics** to the value 5 and **matrix_coefficients** to the value 5.

Decoding: *25 Hz H.264/AVC SDTV IRDs shall support decoding bitstreams with any allowed values of **colour_primaries**, **transfer_characteristics** and **matrix_coefficients**. It is recommended that appropriate processing be included for the accurate representation of pictures using BT. ITU-R Recommendation BT.1700 Part B [25] colorimetry.*

NOTE: Previous editions of the present document referenced ITU-R Recommendation BT.470 [i.4] System B, G colorimetry. ITU-R Recommendation BT.1700 [25] replaces ITU-R Recommendation BT. 470 [i.4].

5.6.2.2 Frame rate

Encoding: *The frame rate shall be 25 Hz in 25 Hz H.264/AVC Bitstreams. This shall be indicated in the VUI by setting `time_scale` and `num_units_in_tick` according to table 7. `Time_scale` and `num_units_in_tick` define the picture rate of the video.*

Table 7: `time_scale` and `num_units_in_tick` for Progressive and Interlace Frame Rates for 25 Hz H.264/AVC SDTV

Frame Rate	Interlaced or Progressive	<code>time_scale</code>	<code>Num_units_in_tick</code>
25	P	50	1
25	I	50	1

Decoding: *25 Hz H.264/AVC SDTV IRDs shall support decoding and displaying video with a frame rate of 25 Hz within the constraints of Main Profile at Level 3. Support of other frame rates is optional.*

5.6.2.3 Luminance resolution

Encoding: *25 Hz H.264/AVC SDTV Bitstreams shall represent video with luminance resolutions as shown in table 8. Non full-screen pictures may be encoded for display at less than full-size (when using one of the standard up-conversion ratios at the 25 Hz H.264/AVC SDTV IRD).*

Decoding: *25 Hz H.264/AVC SDTV IRDs shall be capable of decoding pictures with luminance resolutions as shown in table 8 and applying up sampling to allow the decoded pictures to be displayed at full-screen size. In addition, 25 Hz H.264/AVC SDTV IRDs shall be capable of decoding lower picture resolutions and displaying them at less than full-size after using one of the standard up-conversions, e.g. a horizontal resolution of 704 pixels within the 720 pixels full-screen display.*

Table 8: Resolutions for Full-screen Display from 25 Hz H.264/AVC SDTV IRD and supported by 25 Hz H.264/AVC HDTV IRD, 50 Hz H.264/AVC HDTV IRD, 25 Hz SVC HDTV IRD and 50 Hz SVC HDTV IRD

Coded Picture			Displayed Picture Horizontal up sampling	
Luminance resolution (horizontal x vertical)	Source Aspect Ratio	Aspect_ratio_idc	4:3 Monitors	16:9 Monitors
720 x 576	4:3	2	x 1	x 3/4 (see note 1)
	16:9	4	x 4/3 (see note 2)	x 1
544 x 576	4:3	4	x 4/3	x 1 (see note 1)
	16:9	12	x 16/9 (see note 2)	x 4/3
480 x 576	4:3	10	x 3/2	x 9/8 (see note 1)
	16:9	6	x 2 (see note 2)	x 3/2
352 x 576	4:3	6	x 2	x 3/2 (see note 1)
	16:9	8	x 8/3 (see note 2)	x 2
352 x 288	4:3	2	x 2	x 3/2 (see note 1)
	16:9	4	x 8/3 (see note 2) (and vertical up sampling x 2)	x 2 (and vertical up sampling x 2)

NOTE 1: Up sampling of 4:3 pictures for display on a 16:9 monitor is optional in the IRD, as 16:9 monitors can be switched to operate in 4:3 mode.

NOTE 2: The up sampling with this value is applied to the pixels of the 16:9 picture to be displayed on a 4:3 monitor.

NOTE 3: It is recommended that luminance resolution of 704 pixels represents the "middle" of the picture, and that it be decoded to a 720 pixels full-screen display by placing 8 pixels of padding at each side. It is recommended that luminance resolutions, such as 352 pixels, that are natural scalings of 704 pixels, be upsampled to 704 pixels and padded as above. It is recommended that all other resolutions be scaled as indicated by the table above. Where this does not result in the expected 720 pixels full-screen display, it is recommended that the result of the scaling be clipped or padded symmetrically as required to produce a 720 pixels full-screen display.

5.6.3 30 Hz H.264/AVC SDTV IRD and Bitstream

This clause specifies the 30 Hz H.264/AVC SDTV IRD and Bitstream. *All specifications in clauses 5.5 and 5.6.1 shall apply.* The specification in the remainder of this clause only applies to the 30 Hz H.264/AVC SDTV IRD and Bitstream.

5.6.3.1 Colour Parameter Information

Encoding: *The chromaticity co-ordinates of the ideal display, opto-electronic transfer characteristic of the source picture and matrix coefficients used in deriving luminance and chrominance signals from the red, green and blue primaries shall be explicitly signalled in the encoded H.264/AVC Bitstream by setting the appropriate values for each of the following 3 parameters in the VUI: **colour_primaries**, **transfer_characteristics**, and **matrix_coefficients**.*

It is recommended that ITU-R Recommendation BT.1700 Part A [25] colorimetry is used for video of all other vertical resolutions in the H.264/AVC Bitstream, which is signalled by setting **colour_primaries** to the value 6, **transfer_characteristics** to the value 6 and **matrix_coefficients** to the value 6.

Decoding: *The 30 Hz H.264/AVC SDTV IRD shall be capable of decoding bitstreams with any allowed values of **colour_primaries**, **transfer_characteristics** and **matrix_coefficients**. It is recommended that appropriate processing be included for the accurate representation of pictures using ITU-R Recommendation BT.1700 Part A [25] colorimetry.*

NOTE: Previous editions of the present document referenced SMPTE ST 170 colorimetry [i.9]. ITU-R Recommendation BT.1700 Part A [25] references SMPTE ST 170.

5.6.3.2 Frame rate

Encoding: *The frame rate shall be 24 000/1 001, 24, 30 000/1 001, 30 Hz. This shall be indicated in the VUI by setting **time_scale** and **num_units_in_tick** according to table 9. **Time_scale** and **num_units_in_tick** define the picture rate of the video.*

Table 9: Time_scal and num_units_in_tick for Progressive and Interlace Frame Rates for 30 Hz H.264/AVC SDTV

Frame Rate	Interlaced or Progressive	time_scale	Num_units_in_tick
24 000/ 1 001	P	48 000	1 001
24	P	48	1
30 000/ 1 001	P	60 000	1 001
30	P	60	1
30 000/ 1 001	I	60 000	1 001
30	I	60	1

Decoding: *The 30 Hz H.264/AVC SDTV IRD shall support decoding and displaying video with a frame rate of 24 000/1 001, 24, 30 000/1 001 or 30 Hz within the constraints of Main Profile at Level 3. Support of other frame rates is optional.*

5.6.3.3 Luminance resolution

Encoding: *30 Hz H.264/AVC SDTV Bitstreams shall represent video with luminance resolutions as shown in table 10. Non full-screen pictures may be encoded for display at less than full-size (when using one of the standard up-conversion ratios at the 30 Hz H.264/AVC SDTV IRD).*

Decoding: *30 Hz H.264/AVC SDTV IRDs shall be capable of decoding pictures with luminance resolutions as shown in table 10 and applying up sampling to allow the decoded pictures to be displayed at full-screen size. In addition, 30 Hz H.264/AVC SDTV IRDs shall be capable of decoding lower picture resolutions and displaying them at less than full-size after using one of the standard up-conversions, e.g. a horizontal resolution of 704 pixels within the 720 pixels full-screen display.*

Table 10: Resolutions for Full-screen Display from 30 Hz H.264/AVC SDTV IRD, and supported by 30 Hz H.264/AVC HDTV IRD, 60 Hz H.264/AVC HDTV IRD, 30 Hz SVC HDTV IRD and 60 Hz SVC HDTV IRD

Coded Picture			Displayed Picture Horizontal up sampling	
Luminance resolution (horizontal x vertical)	Source Aspect Ratio	aspect_ratio_idc	4:3 Monitors	16:9 Monitors
720 x 480	4:3	3	x 1	x 3/4 (see note 1)
	16:9	5	x 4/3 (see note 2)	x 1
640 x 480	4:3	1	x 9/8	x 27/32 (see note 1)
	16:9	14	x 3/2	x 9/8
544 x 480	4:3	5	x 4/3	x 1 (see note 1)
	16:9	13	x 16/9 (see note 2)	x 4/3
480 x 480	4:3	11	x 3/2	x 9/8 (see note 1)
	16:9	7	x 2 (see note 2)	x 3/2
352 x 480	4:3	7	x 2	x 3/2 (see note 1)
	16:9	9	x 8/3 (see note 2)	x 2
352 x 240	4:3	3	x 2	x 3/2 (see note 1)
	16:9	5	x 8/3 (see note 2) (and vertical up sampling x 2)	x 2 (and vertical up sampling x 2)

NOTE 1: Up sampling of 4:3 pictures for display on a 16:9 monitor is optional in the IRD, as 16:9 monitors can be switched to operate in 4:3 mode.

NOTE 2: The up sampling with this value is applied to the pixels of the 16:9 picture to be displayed on a 4:3 monitor.

NOTE 3: It is recommended that luminance resolution of 704 pixels represents the "middle" of the picture, and that it be decoded to a 720 pixels full-screen display by placing 8 pixels of padding at each side. It is recommended that luminance resolutions, such as 352 pixels, that are natural scalings of 704 pixels, be upscaled to 704 pixels and padded as above. It is recommended that all other resolutions be scaled as indicated by the table above. Where this does not result in the expected 720 pixels full-screen display, it is recommended that the result of the scaling be clipped or padded symmetrically as required to produce a 720 pixels full-screen display.

5.7 H.264/AVC HDTV IRDs and Bitstreams

5.7.1 Specifications common to all H.264/AVC HDTV IRDs and Bitstreams

The specification in this clause applies to the following IRDs and bitstreams:

- 25 Hz H.264/AVC HDTV IRD and Bitstream;
- 30 Hz H.264/AVC HDTV IRD and Bitstream;
- 50 Hz H.264/AVC HDTV IRD and Bitstream;
- 60 Hz H.264/AVC HDTV IRD and Bitstream.

5.7.1.1 Sequence Parameter Set and Picture Parameter Set

Encoding: *In addition to the provisions set forth in ITU-T Recommendation H.264 / ISO/IEC 14496-10 [16], the following restrictions apply for the fields in the sequence parameter set:*

<i>profile_idc</i>	= 100 (High Profile [16])
<i>constraint_set0_flag</i>	= 0
<i>constraint_set1_flag</i>	= 0
<i>constraint_set2_flag</i>	= 0
<i>constraint_set3_flag</i>	= 0

gaps_in_frame_num_value_allowed_flag = 0 (gaps not allowed)
vui_parameters_present_flag = 1

5.7.1.2 Aspect ratio

Encoding: *The source aspect ratio in H.264/AVC HDTV Bitstreams shall be 16:9.*

*The source aspect ratio information shall be derived from the **aspect_ratio_idc** value in the Video Usability Information (see values of **aspect_ratio_idc** in ITU-T Recommendation H.264 / ISO/IEC 14496-10 [16], table E-1).*

The frame cropping information in the Sequence Parameter Set may be used when appropriate.

Decoding: *H.264/AVC HDTV IRDs shall support decoding and displaying H.264/AVC HDTV Bitstreams with the values of **aspect_ratio_idc** as specified in table 11.*

*The source aspect ratio information shall be derived from the **pic_height_in_map_units_minus1** and the **pic_width_in_mbs_minus1** and the frame cropping information coded in the Sequence Parameter Set as well as the sample aspect ratio encoded with the **aspect_ratio_idc** value in the Video Usability Information (see values of **aspect_ratio_idc** in ITU-T Recommendation H.264 / ISO/IEC 14496-10 [16], table E-1).*

H.264/AVC HDTV IRDs shall support frame cropping.

5.7.1.3 Colour Parameter Information

Encoding: *The chromaticity co-ordinates of the ideal display, opto-electronic transfer characteristic of the source picture and matrix coefficients used in deriving luminance and chrominance signals from the red, green and blue primaries shall be explicitly signalled in the encoded H.264/AVC HDTV Bitstream by setting the appropriate values for each of the following 3 parameters in the **VUI**: **colour_primaries**, **transfer_characteristics**, and **matrix_coefficients**.*

It is recommended that H.264/AVC HDTV bitstreams use either ITU-R Recommendation BT.709 [13] or IEC 61966-2-4 [31] colorimetry.

BT.709 [13] colorimetry usage is signalled by setting **colour_primaries** to the value 1, **transfer_characteristics** to the value 1 and **matrix_coefficients** to the value 1.

IEC 61966-2-4 [31] colorimetry usage is signalled by setting **colour_primaries** to the value 1, **transfer_characteristics** to the value 11 and **matrix_coefficients** to the value 1.

Decoding: *H.264/AVC HDTV IRDs shall be capable of decoding bitstreams with any allowed values of **colour_primaries**, **transfer_characteristics** and **matrix_coefficients**. It is recommended that appropriate processing be included for the accurate representation of pictures using ITU-R Recommendation BT.709 [13] colorimetry.*

H.264/AVC HDTV IRDs may be capable of decoding bitstreams that use IEC 61966-2-4 [31] colorimetry.

NOTE: The H.264/AVC HDTV IRD might not include appropriate processing for the accurate representation of pictures that use IEC 61966-2-4 [31] colorimetry.

5.7.1.4 Luminance resolution

Encoding: *H.264/AVC HDTV Bitstreams shall represent video with luminance resolutions as shown in table 11. Non full-screen pictures may be encoded for display at less than full-size (when using one of the standard up-conversion ratios at the H.264/AVC HDTV IRD).*

Decoding: *H.264/AVC HDTV IRDs shall be capable of decoding pictures with luminance resolutions as shown in table 11 and applying up sampling to allow the decoded pictures to be displayed at full-screen size.*

Table 11: Resolutions for Full-screen Display from H.264/AVC HDTV IRD and SVC HDTV IRD

Coded Picture			
Luminance resolution (horizontal x vertical)	Source Aspect Ratio	aspect_ratio_idc	16:9 Monitors Horizontal up sampling
1 920 x 1 080	16:9	1	x 1
1 440 x 1 080	16:9	14	x 4/3
1 280 x 1 080	16:9	15	x 3/2
960 x 1 080	16:9	16	x 2
1 280 x 720	16:9	1	x 1
960 x 720	16:9	14	x 4/3
640 x 720	16:9	16	x 2

5.7.2 25 Hz H.264/AVC HDTV IRD and Bitstream

This clause specifies the 25 Hz H.264/AVC HDTV IRD and Bitstream. *All specifications in clauses 5.5 and 5.7.1 shall apply.* The specification in the remainder of this clause only applies to the 25 Hz H.264/AVC HDTV IRD and Bitstream.

5.7.2.1 Profile and level

Encoding: 25 Hz H.264/AVC HDTV Bitstreams shall comply with the High Profile Level 4 restrictions, as specified in ITU-T Recommendation H.264 / ISO/IEC 14496-10 [16].

The value of level_idc shall be equal to 30, 31, 32, or 40.

Decoding: 25 Hz H.264/AVC HDTV IRDs shall support the decoding of High Profile Level 4 bitstreams. This requirement includes support for High Profile and levels 3 to 4. Support for profiles and levels other than High Profile, Level 3 to 4 is optional. *If the 25 Hz H.264/AVC HDTV IRD encounters an extension which it cannot decode, it shall discard the following data until the next start code prefix (to allow backward compatible extensions to be added in the future).*

5.7.2.2 Frame rate

Encoding: *The frame rate shall be 25 Hz or 50 Hz. This shall be indicated in the VUI by setting time_scale and num_units_in_tick according to table 12. Time_scale and num_units_in_tick define the picture rate of the video. The source video format for 50 Hz frame rate material shall be progressive. The source video format for 25 Hz frame rate material shall be interlaced or progressive.*

Table 12: Time_scal and num_units_in_tick for Progressive and Interlace Frame Rates for 25 Hz H.264/AVC HDTV, 50 Hz H.264/AVC HDTV, 25 Hz SVC HDTV, 50 Hz SVC HDTV and 25 Hz MVC Stereo HDTV

Frame Rate	Interlaced or Progressive	time_scale	num_units_in_tick
25	P	50	1
25	I	50	1
50	P	100	1

Decoding: 25 Hz H.264/AVC HDTV IRDs shall support decoding and displaying video with a frame rate of 25 Hz interlaced or progressive, or 50 Hz progressive within the constraints of High Profile at Level 4. Support of other frame rates is optional.

5.7.2.3 Backwards Compatibility

Decoding: 25 Hz H.264/AVC HDTV IRDs shall be capable of decoding any bitstream that a 25 Hz H.264/AVC SDTV IRD is required to decode and resulting in the same displayed pictures as the 25 Hz H.264/AVC SDTV IRD, as described in clause 5.6.2.

5.7.3 30 Hz H.264/AVC HDTV IRD and Bitstream

This clause specifies the 30 Hz H.264/AVC HDTV IRD and Bitstream. *All specifications in clauses 5.5 and 5.7.1 shall apply.* The specification in the remainder of this clause only applies to the 30 Hz H.264/AVC HDTV IRD and Bitstream.

5.7.3.1 Profile and level

Encoding: *30 Hz H.264/AVC HDTV Bitstreams shall comply with the High Profile Level 4 restrictions, as specified in ITU-T Recommendation H.264 / ISO/IEC 14496-10 [16].*

The value of level_idc shall be equal to 30, 31, 32, or 40.

Decoding: *30 Hz H.264/AVC HDTV IRDs shall support the decoding of High Profile Level 4 bitstreams. This requirement includes support for High Profile and levels 3 to 4. Support for profiles and levels other than High Profile, Level 3 to 4 is optional. If the 30 Hz H.264/AVC HDTV IRD encounters an extension which it cannot decode, it shall discard the following data until the next start code prefix (to allow backward compatible extensions to be added in the future).*

5.7.3.2 Frame rate

Encoding: *The frame rate shall be 24 000/1 001, 24, 30 000/1 001, 30, 60 000/1 001 or 60 Hz. This shall be indicated in the VUI by setting time_scale and num_units_in_tick according to table 13. Time_scale and num_units_in_tick define the picture rate of the video. The source video format for 24 000/1 001, 24, 60 000/1 001 and 60 Hz frame rate material shall be progressive. The source video format for 30 000/1 001 and 30 Hz frame rate material shall be interlaced or progressive.*

Table 13: Time_scal and num_units_in_tick for Progressive and Interlace Frame Rates for 30 Hz H.264/AVC HDTV, 60 Hz H.264/AVC HDTV, 30 Hz SVC HDTV, 60 Hz SVC HDTV and 30 Hz MVC Stereo HDTV

Frame Rate	Interlaced or Progressive	time_scale	Num_units_in_tick
24 000/ 1 001	P	48 000	1 001
24	P	48	1
30 000/ 1 001	P	60 000	1 001
30	P	60	1
30 000/ 1 001	I	60 000	1 001
30	I	60	1
60 000/ 1 001	P	120 000	1 001
60	P	120	1

Decoding: *30 Hz H.264/AVC HDTV IRDs shall support decoding and displaying video with a frame rate of 30 000/1 001, 30 Hz interlaced or progressive, or 24 000/1 001, 24, 60 000/1 001 or 60 Hz progressive within the constraints of High Profile at Level 4. Support of other frame rates is optional.*

5.7.3.3 Backwards Compatibility

Decoding: *30 Hz H.264/AVC HDTV IRDs shall be capable of decoding any bitstream that a 30 Hz H.264/AVC SDTV IRD is required to decode and resulting in the same displayed pictures as the 30 Hz H.264/AVC SDTV IRD, as described in clause 5.7.2.*

5.7.4 50 Hz H.264/AVC HDTV IRD and Bitstream

This clause specifies the 50 Hz H.264/AVC HDTV IRD and Bitstream. *All specifications in clauses 5.5 and 5.7.1 shall apply.* The specification in the remainder of this clause only applies to the 50 Hz H.264/AVC HDTV IRD and Bitstream.

5.7.4.1 Profile and level

Encoding: *50 Hz H.264/AVC HDTV Bitstreams shall comply with the High Profile Level 4.2 restrictions, as specified in ITU-T Recommendation H.264 / ISO/IEC 14496-10 [16].*

*The value of **level_idc** shall be equal to 41 or 42.*

Decoding: *50 Hz H.264/AVC HDTV IRDs shall support the decoding of High Profile Level 4.2 bitstreams. This requirement includes support for High Profile and levels 4.1 and 4.2. Support for profiles and levels other than High Profile, Level 4.1 and 4.2 is optional. If the 50 Hz H.264/AVC HDTV IRD encounters an extension which it cannot decode, it shall discard the following data until the next start code prefix (to allow backward compatible extensions to be added in the future).*

5.7.4.2 Frame rate

Encoding: *The frame rate shall be 25 Hz or 50 Hz. This shall be indicated in the VUI by setting **time_scale** and **num_units_in_tick** according to table 12. Time_scale and num_units_in_tick define the picture rate of the video. The source video format for 50 Hz frame rate material shall be progressive. The source video format for 25 Hz frame rate material shall be interlaced or progressive.*

Decoding: *50 Hz H.264/AVC HDTV IRDs shall support decoding and displaying video with a frame rate of 25 Hz interlaced or progressive, or 50 Hz progressive within the constraints of High Profile at Level 4.2. Support of other frame rates is optional.*

5.7.4.3 Backwards Compatibility

Decoding: *50 Hz H.264/AVC HDTV IRDs shall be capable of decoding any bitstream that a 25 Hz H.264/AVC HDTV IRD is required to decode and resulting in the same displayed pictures as the 25 Hz H.264/AVC HDTV IRD, as described in clause 5.7.2.*

5.7.5 60 Hz H.264/AVC HDTV IRD and Bitstream

This clause specifies the 60 Hz H.264/AVC HDTV IRD and Bitstream. *All specifications in clauses 5.5 and 5.7.1 shall apply.* The specification in the remainder of this clause only applies to the 60 Hz H.264/AVC HDTV IRD and Bitstream.

5.7.5.1 Profile and level

Encoding: *60 Hz H.264/AVC HDTV Bitstreams shall comply with the High Profile Level 4.2 restrictions, as specified in ITU-T Recommendation H.264 / ISO/IEC 14496-10 [16].*

*The value of **level_idc** shall be equal to 41 or 42.*

Decoding: *60 Hz H.264/AVC HDTV IRDs shall support the decoding of High Profile Level 4.2 bitstreams. This requirement includes support for High Profile and levels 4.1 and 4.2. Support for profiles and levels other than High Profile, Level 4.1 and 4.2 is optional. If the 60 Hz H.264/AVC HDTV IRD encounters an extension which it cannot decode, it shall discard the following data until the next start code prefix (to allow backward compatible extensions to be added in the future).*

5.7.5.2 Frame rate

Encoding: *The frame rate shall be 24 000/1 001, 24, 30 000/1 001, 30, 60 000/1 001 or 60 Hz. This shall be indicated in the VUI by setting **time_scale** and **num_units_in_tick** according to table 13. Time_scale and num_units_in_tick define the picture rate of the video. The source video format for 24 000/1 001, 24, 60 000/1 001 and 60 Hz frame rate material shall be progressive. The source video format for 30 000/1 001 and 30 Hz frame rate material shall be interlaced or progressive.*

Decoding: *60 Hz H.264/AVC HDTV IRDs shall support decoding and displaying video with a frame rate of 30 000/1 001, 30 Hz interlaced or progressive, or 24 000/1 001, 24, 60 000/1 001 or 60 Hz progressive within the constraints of High Profile at Level 4.2. Support of other frame rates is optional.*

5.7.5.3 Backwards Compatibility

Decoding: *60 Hz H.264/AVC HDTV IRDs shall be capable of decoding any bitstream that a 30 Hz H.264/AVC HDTV IRD is required to decode and resulting in the same displayed pictures as the 30 Hz H.264/AVC HDTV IRD, as described in clause 5.7.3.*

5.8 SVC HDTV IRDs and Bitstreams

5.8.1 Specifications common to all SVC HDTV IRDs and Bitstreams

The specification in this clause applies to the following IRDs and bitstreams:

- 25 Hz SVC HDTV IRD and Bitstream;
- 30 Hz SVC HDTV IRD and Bitstream;
- 50 Hz SVC HDTV IRD and Bitstream;
- 60 Hz SVC HDTV IRD and Bitstream.

The restrictions for SVC HDTV Bitstreams and the capabilities for SVC HDTV IRDs are partly specified via SVC HDTV Bitstream Subsets. An SVC HDTV Bitstream Subset is a subset of an SVC HDTV Bitstream that can be obtained from the SVC HDTV Bitstream by discarding one or more access units and/or one or more VCL NAL units, starting from VCL NAL units with the largest value of DQId, and associated non-VCL NAL units in one or more access units, similar to the process specified in clause G.8.8.1 of ITU-T Recommendation H.264 / ISO/IEC 14496-10 [16]. An SVC HDTV Bitstream Subset may be identical to the SVC HDTV Bitstream that contains the SVC HDTV Bitstream Subset. Some of the restriction for SVC HDTV Bitstreams and capabilities for SVC HDTV IRDs are specified by specifying restrictions for SVC HDTV Bitstream Subsets.

5.8.1.1 Classes of SVC operation

The video encoding and video decoding shall conform to ITU-T Recommendation H.264 / ISO/IEC 14496-10 [16]. Some of the parameters and fields are not used in the DVB System and these restrictions are described below. SVC Bitstreams and IRDs shall support some parts of the "Supplemental Enhancement Information (SEI)", the "Video usability information (VUI)", and the "SVC Video Usability Information extension (SVC VUI extension)" syntax elements as specified in ITU-T Recommendation H.264 / ISO/IEC 14496-10 [16] annexes D and E and clauses G.13 and G.14. The SVC IRD design shall be made under the assumption that any legal structure as permitted by ITU-T Recommendation H.264 / ISO/IEC 14496-10 [16] and the restrictions that are specified for the SVC IRDs may occur in the broadcast stream even if presently reserved or unused.

5.8.1.1.1 Class S Bitstream

Number of dependency representations:

Decoding: *Class S IRDs shall be capable of ignoring VCL NAL units (of an SVC Bitstream) that have dependency_id greater than 1.*

Class S IRDs shall be capable of decoding and rendering pictures that are represented by an SVC Bitstream Subset that does not contain VCL NAL units with dependency_id greater than 1.

Number of layer representations:

Encoding: *In class S Bitstreams, VCL NAL units with dependency_id equal to 1 and quality_id equal to 0 shall have ref_layer_dq_id equal to 0.*

Decoding: *Class S IRDs shall be capable of ignoring VCL NAL units (of an SVC Bitstream) that have quality_id greater than 0.*

Class S IRDs shall be capable of decoding and rendering pictures that are represented by an SVC Bitstream Subset that does not contain VCL NAL units with quality_id greater than 0.

store_ref_base_pic_flag:

Encoding: *In class S bitstreams, VCL NAL units with dependency_id less than or equal to 1 shall have store_ref_base_pic_flag equal to 0.*

5.8.1.1.2 Class Q Bitstream

Number of dependency representations:

Decoding: *Class Q IRDs shall be capable of ignoring VCL NAL units (of an SVC Bitstream) that have dependency_id greater than 0.*

Class Q IRDs shall be capable of decoding and rendering pictures that are represented by an SVC Bitstream Subset that does not contain VCL NAL units with dependency_id greater than 0.

Number of layer representations:

Decoding: *Class Q IRDs shall be capable of ignoring VCL NAL units (of an SVC Bitstream) that have quality_id greater than 3.*

Class Q IRDs shall be capable of decoding and rendering pictures that are represented by an SVC Bitstream Subset that does not contain VCL NAL units with quality_id greater than 3.

store_ref_base_pic_flag:

Encoding: *In class Q Bitstreams, time interval between any two SVC access units (in decoding order) that contain VCL NAL units with dependency_id equal to 0 and store_ref_base_pic_flag equal to 1 shall be greater than or equal to 100 ms.*

5.8.1.1.3 Class M Bitstream

Number of dependency representations:

Decoding: *Class M IRDs shall be capable of ignoring VCL NAL units (of an SVC Bitstream) that have dependency_id greater than 1.*

Class M IRDs shall be capable of decoding and rendering pictures that are represented by an SVC Bitstream Subset that does not contain VCL NAL units with dependency_id greater than 1.

Number of layer representations:

Encoding: *In class M Bitstreams, VCL NAL units with dependency_id equal to 1 and quality_id equal to 0 shall have ref_layer_dq_id less than 3.*

Decoding: *Class M IRDs shall be capable of discarding VCL NAL units (of an SVC Bitstream) in a way that the set of not discarded VCL NAL units does not contain more than 4 different values of DQId (the value of DQId for VCL NAL units is given by $16 * \text{dependency_id} + \text{quality_id}$), before decoding and rendering pictures.*

*Class M IRDs shall be capable of decoding and rendering pictures that are represented by an SVC Bitstream Subset that does not contain more than 4 different values of DQId (the value of DQId for VCL NAL units is given by $16 * \text{dependency_id} + \text{quality_id}$).*

store_ref_base_pic_flag:

Encoding: *In class M Bitstreams, time interval between any two SVC access units (in decoding order) that contain VCL NAL units with dependency_id equal to 0 or 1 and store_ref_base_pic_flag equal to 1 shall be greater than or equal to 100 ms.*

5.8.1.2 System Considerations

As provided below, certain aspects of an SVC system are signalled using "Video Usability Information"(VUI) parameters. These include picture colorimetry and picture Chrominance locations. When using SVC video coding, these parameters are strongly recommended to be identical within each layer of the AVC and SVC associated bitstreams. If they are not identical, then great care should be taken in system design and operation.

5.8.1.3 SVC Sequence Parameter Set and Picture Parameter Set

Encoding: More than one picture parameter set can be present in the bitstreams between two SVC RAPs. *Between two SVC RAPs for the same value of **dependency_id**, the content of a picture parameter set with a particular **pic_parameter_set_id** shall not change. I.e. if more than one picture parameter set is present in the bitstream and these picture parameter sets are different from each other, then each picture parameter set shall have a different **pic_parameter_set_id**.*

Note that multiple PPSs may be present in an SVC RAP access unit and the number of PPS that may be present is constrained by clause 4.1.5.2 where the start of the SVC dependency representation (which may be indicated by the Access Unit Delimiter or the SVC dependency representation delimiter) and the start of the first slice of the SVC dependency representation must occur either in the same transport packet or in 2 successive transport packets.

5.8.1.3.1 **pic_width_in_mbs_minus1** and **pic_height_in_map_units_minus1**

Encoding: *The time interval between any two of the following changes shall be greater than or equal to one second:*

- a change of **DependencyIdMax** (**DependencyIdMax** specifies the maximum value of **dependency_id** present in an access unit);
- for any present value of **dependency_id**, a change of **pic_width_in_mbs_minus1** or **pic_height_in_map_units_minus1**;
- for any present value of **dependency_id** greater than 0, a change of **scaled_ref_layer_left_offset**, **scaled_ref_layer_right_offset**, **scaled_ref_layer_top_offset** or **scaled_ref_layer_bottom_offset** in the layer representations with **quality_id** equal to 0;
- for any present value of **dependency_id** greater than 0, a change of **ref_layer_dq_id** in the layer representations with **quality_id** equal to 0 and **no_inter_layer_pred_flag** equal to 0.

NOTE: Any of the above mentioned changes requires software processing in the decoder. Limiting the frequency of these changes is to constrain the IRD software processing.

If the number of samples per row of the luminance component of the source picture for any SVC dependency representation is not an integer multiple of 16 and additional samples are padded to make the number of samples per row of the luminance component an integer multiple of 16, it is recommended that these samples are padded at the right side of the picture.

If the number of samples per column of the luminance component of the source picture for any SVC dependency representation is not an integer multiple of 16 and additional samples are padded to make the number of samples per column of the luminance component an integer multiple of 16, it is recommended that these samples are padded at the bottom of the picture.

5.8.1.3.2 Subset Sequence Parameter Set

Encoding: *In addition to the provisions set forth in ITU-T Recommendation H.264 / ISO/IEC 14496-10 [16], the following restrictions shall apply for the fields in the subset sequence parameter sets (**nal_unit_type** is equal to 15):*

profile_idc	= 86 (Scalable High Profile [16])
constraint_set1_flag	= 1
constraint_set2_flag	= 0

<i>gaps_in_frame_num_value_allowed_flag</i>	= 0 (gaps not allowed)
<i>vui_parameters_present_flag</i>	= 1
<i>svc_vui_parameters_present_flag</i>	= 1
<i>seq_ref_layer_chroma_phase_x_plus1_flag</i>	= <i>chroma_phase_x_plus1_flag</i>
<i>seq_ref_layer_chroma_phase_y_plus1</i>	= <i>chroma_phase_y_plus1</i>

The SVC Video Usability Information extension shall include information for all present combinations of *dependency_id*, *quality_id* and *temporal_id* applicable for the subset sequence parameter set.

NOTE: Restrictions for sequence parameter sets (*nal_unit_type* equal to 7), which are referenced in VCL NAL units with *dependency_id* equal to 0 and *quality_id* equal to 0 are specified by the constraints for the SVC base layer bitstream in clauses 5.8.2.2, 5.8.3.2, 5.8.4.2 and 5.8.5.2.

5.8.1.4 Video Usability Information

The IRD shall support the use of the following syntax elements in the Video Usability Information of sequence parameter sets (*nal_unit_type* is equal to 7) and subset sequence parameter sets (*nal_unit_type* is equal to 15):

- Aspect Ratio Information (*aspect_ratio_idc*).
- Colour Parameter Information (*colour_primaries*, *transfer_characteristics*, and *matrix_coefficients*).
- Chrominance Information (*chroma_sample_loc_type_top_field* and *chroma_sample_loc_type_bottom_field*).

The IRD shall support the use of the following syntax elements in the Video Usability Information of sequence parameter sets (*nal_unit_type* is equal to 7):

- Timing information (*time_scale*, *num_units_in_tick*, and *fixed_frame_rate_flag*).
- Picture Structure Information (*pic_struct_present_flag*).

The IRD shall support the use of the following syntax elements in the SVC Video Usability Information extension of subset sequence parameter sets (*nal_unit_type* is equal to 15), for each value *i* in the range of 0 to *num_layers_minus1*, inclusive, with *num_layers_minus1* being the corresponding field in the SVC Video Usability Information extension:

- Timing information (*time_scale*[*i*], *num_units_in_tick*[*i*], and *fixed_frame_rate_flag*[*i*]).
- Picture Structure Information (*pic_struct_present_flag*[*i*]).

5.8.1.4.1 Aspect Ratio Information

The support of **aspect_ratio_idc** values for 25 Hz SVC HDTV IRDs and Bitstreams, 30 Hz SVC HDTV IRDs and Bitstreams, 50 Hz SVC HDTV IRDs and Bitstreams and 60 Hz SVC HDTV IRDs and Bitstreams is specified in clauses 5.8.2.5, 5.8.3.5, 5.8.4.5 and 5.8.5.5, respectively.

5.8.1.4.2 Colour Parameter Information

Encoding: *The chromaticity co-ordinates of the ideal display, opto-electronic transfer characteristic of the source picture and matrix coefficients used in deriving luminance and chrominance signals from the red, green and blue primaries shall be explicitly signalled in the encoded SVC HDTV Bitstream by setting the appropriate values for each of the following 3 parameters in the VUI of all SVC Sequence Parameter Sets: colour_primaries, transfer_characteristics, and matrix_coefficients.*

It is strongly recommended that the VUIs of all SVC Sequence Parameter Sets that are referenced in the VCL NAL units of any particular access unit include the same values of **colour_primaries**, **transfer_characteristics**, and **matrix_coefficients**.

Decoding: *SVC HDTV IRDs shall be capable of decoding bitstreams with any allowed values of colour primaries, transfer_characteristics and matrix_coefficients in the VUI of the SVC Sequence Parameter Sets. It is recommended that appropriate processing be included for the accurate representation of pictures using ITU-R Recommendation BT.709 [13] colorimetry; and it is recommended that appropriate processing be included for the accurate representation of pictures using ITU-R Recommendation BT.1700 Part B [25] colorimetry for 25 Hz and 50 Hz SVC IRDs and Bitstreams and ITU-R Recommendation BT.1700 Part A [25] colorimetry for 30 Hz and 60 Hz SVC IRDs and Bitstreams.*

If a SVC IRD receives a SVC bitstream with an AVC video sub-bitstream and an SVC video sub-bitstream, and decodes only the AVC video sub-bitstream and outputs a scaled version of this video sub-bitstream at a resolution matching the SVC video sub-bitstream, it is recommended that the colour parameters of the AVC video sub-bitstream be converted, if they are different, to match those of the SVC video sub-bitstream.

5.8.1.4.3 Chrominance Information

Encoding: It is recommended to specify the chrominance locations using the syntax elements **chroma_sample_loc_type_top_field** and **chroma_sample_loc_type_bottom_field** in the VUI of each SVC Sequence Parameter set. It is recommended to use chroma sample type equal to 0 for both fields.

It is strongly recommended that the chrominance locations specified by the syntax elements **chroma_phase_x_plus1_flag** and **chroma_phase_y_plus1** of a subset sequence parameter set be consistent with the chrominance locations specified in the VUI of the same subset sequence parameter set, as per ITU-T Recommendation H.264 | ISO/IEC 14496-10 [16].

It is recommended that the reference layer chrominance locations specified by the syntax elements **ref_layer_chroma_phase_x_plus1_flag** and **ref_layer_chroma_phase_y_plus1** be consistent with the chrominance locations specified in the VUI of the SVC sequence parameter set that is referenced in the reference SVC layer representation (specified by **ref_layer_dq_id**), as per ITU-T Recommendation H.264 | ISO/IEC 14496-10 [16].

Decoding: *SVC HDTV IRDs shall support decoding any allowed values of chroma_sample_loc_type_top_field and chroma_sample_loc_type_bottom_field. It is recommended that appropriate processing be included for the display of pictures.*

If a SVC IRD receives a SVC bitstream with an AVC video sub-bitstream and an SVC video sub-bitstream, and decodes only the AVC video sub-bitstream and outputs a scaled version of this video sub-bitstream at a resolution matching the SVC video sub-bitstream, it is recommended that the chrominance parameters of the AVC video sub-bitstream be converted, if they are different, to match those of the SVC video sub-bitstream.

5.8.1.4.4 Timing Information

The support of **time_scale** and **num_units_in_tick** values in the VUI of sequence parameter sets and **time_scale[i]** and **num_units_in_tick[i]** values, for all present values of *i*, in the SVC VUI extension of subset sequence parameter sets for the 25 Hz SVC HDTV IRD and Bitstream is specified in clause 5.8.2.3, for the 30 Hz SVC HDTV IRD and Bitstream is specified in clause 5.8.3.3, for the 50 Hz SVC HDTV IRD and Bitstream is specified in clause 5.8.4.3, and for the 25 Hz SVC HDTV IRD and Bitstream is specified in clause 5.8.5.3. *In case of still picture, the value of **fixed_frame_rate_flag** in the VUI of sequence parameter sets and the value of **fixed_frame_rate_flag[i]**, for all present values of *i*, in the SVC VUI extension of subset sequence parameter sets shall be equal to 0. In other cases, the value of **fixed_frame_rate_flag** in the VUI of sequence parameter sets and the value of **fixed_frame_rate_flag[i]**, for all present values of *i*, in the SVC VUI extension of subset sequence parameter sets shall be equal to 1.* The frame rate for any video sub-bitstream cannot be changed between two access units that represent SVC IDR pictures for all present values of **dependency_id**.

5.8.1.4.5 Picture Structure Information

The support of **pic_struct_present_flag** in the VUI of sequence parameter sets and **pic_struct_present_flag[i]**, for the present values of *i*, in the SVC VUI extension of subset sequence parameter sets is specified in clause 5.8.1.5.1 related to use of Picture Structure information in the Picture Timing SEI and is common to all SVC HDTV IRDs and Bitstreams. For sequences that carry the picture structure information (such as film mode), it is recommended that the **pic_struct_present_flag** be set to 1 in the VUIs of the sequence parameter sets, the **pic_struct_present_flag[i]** be set equal to 1 for the present values of *i* in the SVC VUI extensions of the subset sequence parameter sets and corresponding picture timing SEI messages are associated with each access unit in the coded sequence. If the sequence does not require picture structure information, then the **pic_struct_present_flag** should be set to equal to 0 in the VUIs of the sequence parameter sets and the **pic_struct_present_flag[i]** should be set equal to 0 for the present values of *i* in the SVC VUI extensions of the subset sequence parameter sets. Use of the **pic_struct_present_flag** field in the VUI of sequence parameter sets and the **pic_struct_present_flag[i]** fields in the SVC VUI extension of subset sequence parameter sets allows use of corresponding picture timing SEI messages with only the picture structure information without the need to include HRD information (such as CPB and DPB delay or initial values of the delay in the corresponding buffering period SEI messages).

5.8.1.5 Supplemental Enhancement Information

The IRD shall support the use of Supplemental Enhancement Information of the following message types:

- Picture Timing SEI Message;
- Pan-Scan Rectangle SEI Message;
- "User data registered by ITU-T Recommendation T.35 SEI message" syntactic element [19] **user_data_registered_itu_t_35** as defined in clause B.7;
- Scalable Nesting SEI Message with nested SEI messages being Picture Timing or Pan-Scan Rectangle SEI messages.

Encoding: *The SVC video sub-bitstream shall not contain any NAL units with nal_unit_type equal to 6 (SEI NAL units).*

NOTE 1: All SEI messages that apply to SVC enhancement layers should be included in the AVC video sub-bitstream (i.e. the video sub-bitstream with dependency_id equal to 0). This ensures that the access unit re-assembling process does not require any re-ordering of NAL units.

NOTE 2: Even though SVC SEI messages other than those defined above are not precluded, transmission systems and broadcasters should take into account that the inclusion of any optional SEI messages could significantly increase the bitrate and buffer utilization of the base layer AVC video sub-bitstream. (Optional SEI messages include SEI messages other than the following: Picture Timing SEI message, Pan-Scan Rectangle SEI message, User data registered by ITU-T Recommendation T.35 [19] SEI message, Scalable Nesting SEI message with one or more of the nested SEI messages not being a Picture Timing SEI message or a Pan-Scan Rectangle SEI message).

5.8.1.5.1 Picture Timing SEI Message

Encoding: *If the SVC HDTV Bitstream contains picture structure information, then the **pic_struct_present_flag** shall be set equal to 1 in the VUI of the sequence parameter sets, the **pic_struct_present_flag[i]** shall be set equal to 1 for the present values of *i* in the SVC VUI extension of the subset sequence parameter sets and corresponding Picture Timing SEI messages shall be associated with every access unit. All Picture Timing SEI messages that apply to SVC layer representations of the same SVC dependency representation shall have the same value of **pic_struct**. If the SVC HDTV Bitstream does not contain picture structure information, the **pic_struct_present_flag** shall be set to 0 in the VUI of the sequence parameter sets and the **pic_struct_present_flag[i]** shall be set equal to 1 for the present values of *i* in the SVC VUI extension of the subset sequence parameter sets.*

Decoding: *SVC HDTV IRDs shall support all values defined in **pic_struct** including all modes requiring field and frame repetition. The SVC HDTV IRDs need not make use of any other syntax elements (except **pic_struct**) in the Picture Timing SEI messages, if these elements are present.*

NOTE: Picture Timing SEI messages are included in corresponding Scalable Nesting SEI messages when their presence is signalled by the field `pic_struct_present_flag[i]` in the SVC VUI extension of subset sequence parameter sets and Picture Timing SEI messages are not included in Scalable Nesting SEI messages when their presence is signalled by the field `pic_struct_present_flag` in the VUI of sequence parameter sets (per ITU-T Recommendation H.264 / ISO/IEC 14496-10 [16]).

If present, the picture structure information conveys the picture output order in the same order as the Picture Order Count (POC) information in the SVC HDTV Bitstream (per clause D.2.2 of ITU-T Recommendation H.264 / ISO/IEC 14496-10 [16]). This ensures consistency between the SEI message and the HRD model of ITU-T Recommendation H.264 / ISO/IEC 14496-10 [16].

5.8.1.5.2 Pan-Scan Rectangle SEI Message

Encoding: The **pan_scan_rect** SEI message may be used when appropriate.

Decoding: SVC HDTV IRDs shall support all values specified in the **pan_scan_rect** SEI message for all video sub-bitstreams, except **pan_scan_rect_top_offset[i]** and **pan_scan_rect_bottom_offset[i]**. The SVC HDTV IRD need not make use of **pan_scan_rect_top_offset[i]** and **pan_scan_rect_bottom_offset[i]** parameters in the **pan_scan_rect** SEI message.

The support of the use of **pan_scan_rect** for up sampling is specified to allow a 4:3 monitor to give a full-screen display of a selected portion of a 16:9 coded picture with the correct aspect ratio. The support of vertical resampling to obtain the correct aspect ratio for a letterbox display of a 16:9 coded picture on a 4:3 monitor is optional.

NOTE 1: Pan-Scan Rectangle SEI messages that apply to dependency representations with `dependency_id` greater than 0 are included in Scalable Nesting SEI messages.

NOTE 2: Use of AFD as defined in clause B.3 and Bar Data as defined in clause B.4 may provide a more convenient mechanism for enabling the full screen display of a selected portion of the coded picture.

5.8.1.5.3 Scalable Nesting SEI Message

Encoding: SEI messages that are associated with SVC dependency representations with `dependency_id` greater than 0 or with SVC layer representations with `dependency_id` greater than 0 or `quality_id` greater than 0 or with particular bitstream subsets shall be included in Scalable Nesting SEI messages, as specified in ITU-T Recommendation H.264 / ISO/IEC 14496-10 [16].

Decoding: SVC HDTV IRDs shall support Scalable Nesting SEI messages and shall associate the nested SEI messages (i.e. SEI messages included in a Scalable Nesting SEI message) with the SVC dependency representations or SVC layer representations or particular bitstream subsets indicated by the parameters of the Scalable Nesting SEI message, as specified in ITU-T Recommendation H.264 / ISO/IEC 14496-10 [16].

5.8.1.5.4 Still pictures

Encoding: Still pictures shall comply with "AVC still picture" definition as per ITU-T Recommendation H.222.0 / ISO/IEC 13818-1 [1]. For Still pictures the frame rate specification for SVC HDTV IRDs shall not apply. The value of **fixed_frame_rate_flag** in the VUI of sequence parameter sets and the values of **fixed_frame_rate_flag[i]** in the SVC VUI extension of subset sequence parameter sets shall be equal to 0.

For display that requires a fixed frame refresh according to the IRD frequency, the previously decoded picture should be displayed till the next picture is available.

5.8.1.6 SVC Random Access Point

The definitions of SVC RAP and SVC random access dependency representation in clause 3 shall apply.

Encoding: The time interval between SVC RAPs (for each particular value of `dependency_id`) may vary between programs and also within a program. The broadcast requirements should set the time interval between SVC RAPs as specified in clause 5.8.1.6.1.

NOTE: The AU_information_descriptor described in annex D provides a means of signalling information about Random Access Points that may be used by some applications, and it is recommended that this is present.

For each particular value of dependency_id, all SVC layer pictures with this particular value of dependency_id and PTS greater than or equal to PTS(rap) shall be fully reconstructible and displayable, where PTS(rap) represents the Presentation Time Stamp of the picture of the SVC RAP for this particular value of dependency_id. This means that decoders receiving an SVC RAP for a particular value of dependency_id shall not need to utilise data transmitted prior to this SVC RAP to decode SVC layer pictures with this particular value of dependency_id that are displayed after the this SVC RAP.

If an SVC access unit represents an SVC RAP for a particular value of dependency_id, it shall also represent an SVC RAP for all values of dependency_id in the range from 0 to the particular value of dependency_id minus 1, inclusive.

If the maximum present value of dependency_id in an SVC access unit is different from the maximum present value of dependency_id in the previous SVC access unit in decoding order (when present), the SVC access unit shall represent an SVC RAP for all values of dependency_id present in the access unit.

To improve applications such as channel change, it is recommended that the Presentation Time Stamp of the picture of an SVC RAP be less than or equal to [DTS(rap) + 0,5 seconds] where DTS(rap) represents the Decoding Time Stamp of the picture of the SVC RAP.

Packetization of random access points shall comply with the following additional rule:

*A transport packet containing the PES header of an SVC random access dependency representation shall have an adaptation field. The **payload_unit_start_indicator** bit shall be set to "1" in the transport packet header and the **adaptation_field_control** bits shall be set to "11" (as per ITU-T Recommendation H.222.0 / ISO/IEC 13818-1 [1]). In addition, the **random_access_indicator** bit in the adaptation header shall be set to "1". The **elementary_stream_priority_indicator** bit shall also be set to "1" in the same adaptation header if this transport packet contains the slice start code of the SVC random access dependency representation (see clauses 4.1.5.1 and 4.1.5.2).*

Decoding: *SVC HDTV IRDs shall be capable of starting decoding and displaying pictures represented by an SVC HDTV Bitstream Subset, contained in an SVC HDTV Bitstream, at any SVC RAP with MaxDIdRAP equal to MaxDId. MaxDIdRAP represents the maximum value of dependency_id that is associated with the SVC RAP in the SVC HDTV Bitstream Subset and MaxDId represented the maximum value of dependency_id that is present in the SVC RAP in the SVC HDTV Bitstream Subset.*

5.8.1.6.1 Time Interval Between SVC RAPs

Encoding: *The encoder shall place SVC RAPs for dependency_id equal to 0 in the video elementary stream at least once every 5 s. It is recommended that SVC RAPs for dependency_id equal to 0 occur in the video elementary stream on average at least every 2 s. Where rapid channel change times are important or for applications such as PVR it may be appropriate for SVC RAPs for dependency_id equal to 0 to occur more frequently, such as every 500 ms.*

For each time interval in which dependency representations with any particular value of dependency_id greater than 0 are present in an SVC HDTV Bitstream, the encoder shall place SVC RAPs for this particular value of dependency_id in the video elementary stream at least once every 10 s. It is recommended that, for each time interval in which dependency representations with any particular value of dependency_id greater than 0 are present in an SVC HDTV Bitstream, SVC RAPs for this particular value of dependency_id occur in the video elementary stream on average at least every 5 s.

The time interval between successive RAPs for a particular value of dependency_id shall be measured as the difference between their respective DTS values.

- NOTE 1: An SVC RAP for a particular value of `dependency_id` may or may not represent an SVC RAP for greater values of `dependency_id`.
- NOTE 2: Decreasing the time interval between SVC RAPs may reduce channel hopping time and improve trick modes, but may reduce the efficiency of the video compression.
- NOTE 3: Having a regular interval between SVC RAPs may improve trick mode performance, but may reduce the efficiency of the video compression.

5.8.2 25 Hz SVC HDTV IRD and Bitstream

This clause specifies the 25 Hz SVC HDTV IRD and Bitstream. *All specifications in clause 5.8.1 shall apply.* The specification in the remainder of this clause only applies to the 25 Hz SVC HDTV IRD and Bitstream.

5.8.2.1 Profile and level

Encoding: *25 Hz SVC HDTV Bitstream Subsets shall comply with the Scalable High Profile Level 4 restrictions, as specified in ITU-T Recommendation H.264 / ISO/IEC 14496-10 [16].*

The value of `level_idc` in all sequence parameter sets and subset sequence parameter sets that are referenced in VCL NAL units of a 25 Hz SVC HDTV Bitstream Subset shall be equal to 30, 31, 32, or 40.

25 Hz SVC HDTV Bitstreams shall conform to ITU-T Recommendation H.264 / ISO/IEC 14496-10 [16] and shall contain one or more 25 Hz SVC HDTV Bitstream Subsets. Optionally, 25 Hz SVC HDTV Bitstreams may contain additional VCL NAL units and associated non-VCL NAL units that do not belong to any 25 Hz SVC HDTV Bitstream Subset.

Decoding: *25 Hz SVC HDTV IRDs shall be capable of decoding and rendering pictures using 25 Hz SVC HDTV Bitstreams. Support for SVC Bitstreams that do not contain 25 Hz SVC HDTV Bitstream Subsets is optional.*

25 Hz SVC HDTV IRDs shall be capable of decoding and rendering pictures that are represented by 25 Hz SVC HDTV Bitstream Subsets contained in a 25 Hz SVC HDTV Bitstream. 25 Hz SVC HDTV IRDs shall be capable of discarding the VCL NAL units of a 25 Hz SVC HDTV Bitstream that do not belong to a 25 Hz SVC HDTV Bitstream Subset, before decoding and rendering pictures. Support for decoding and rendering of pictures that are represented by a SVC Bitstream Subset with a conformance point beyond the conformance point of 25 Hz SVC HDTV Bitstream Subsets is optional.

If the 25 Hz SVC HDTV IRD encounters an extension which it cannot decode, it shall discard the following data until the next start code prefix (to allow backward compatible extensions to be added in the future).

5.8.2.2 25 Hz SVC base layer bitstream

Encoding: *The SVC base layer bitstream of a 25 Hz SVC HDTV Bitstream (and a 25 Hz SVC HDTV Bitstream Subset) shall obey all constraints of a 25 Hz H.264/AVC SDTV Bitstream or all constraints of a 25 Hz H.264/AVC HDTV Bitstream.*

5.8.2.3 Frame rate

Encoding: *The frame rate of each video sub-bitstream of a 25 Hz SVC HDTV Bitstream Subset shall be 25 Hz or 50 Hz. This shall be indicated in the VUI of the sequence parameter sets referenced in VCL NAL units of the video sub-bitstream by setting **time_scale** and **num_units_in_tick** according to table 12 and the SVC VUI extension of the subset sequence parameter sets referenced in VCL NAL units of the video sub-bitstream by setting **time_scale[i]** and **num_units_in_tick[i]** for all present values of *i* according to table 12 with substituting **time_scale[i]** for **time_scale** and substituting **num_units_in_tick[i]** for **num_units_in_tick**. The fields **time_scale** and **num_units_in_tick** in the VUI of sequence parameter sets and the fields **time_scale[i]** and **num_units_in_tick[i]** in the SVC VUI extension of subset sequence parameter sets define the picture rate of the video.*

The source video format for 50 Hz frame rate video sub-bitstreams of a 25 Hz SVC HDTV Bitstream should be progressive. The source video format for 25 Hz frame rate video sub-bitstreams of a 25 Hz SVC Bitstream may be interlaced or progressive.

*The frame rate of any video sub-bitstream, of a 25 Hz SVC HDTV Bitstream, with a particular value of **dependency_id** greater than 0 shall be an integer multiple of the frame rates of all video sub-bitstreams with smaller values of **dependency_id**.*

*If a 25 Hz SVC HDTV Bitstream Subset contains a video sub-bitstream with **dependency_id** equal to 1 and the source format for this video sub-bitstream is interlaced, the source video format for the video sub-bitstream with **dependency_id** equal to 0 shall also be interlaced.*

Decoding: *25 Hz SVC HDTV IRDs shall support decoding and displaying video, represented by a 25 Hz SVC HDTV Bitstream Subset, with a frame rate of 25 Hz interlaced or progressive or 50 Hz progressive. Support of other frame rates is optional.*

5.8.2.4 Luminance resolution

Encoding: *Each video sub-bitstream of a 25 Hz SVC HDTV Bitstream Subset shall represent video with luminance resolutions as shown in table 8 and table 11. Non full-screen pictures may be encoded for display at less than full-size (when using one of the standard up-conversion ratios at the 25 Hz SVC HDTV IRD).*

*If a 25 Hz SVC HDTV Bitstream Subset contains a video sub-bitstream with **dependency_id** equal to 1 and this video sub-bitstream has **frame_mbs_only_flag** equal to 0, the value of **frame_mbs_only_flag** for the video sub-bitstream with **dependency_id** equal to 0 shall also be equal to 0.*

Decoding: *25 Hz SVC HDTV IRDs shall be capable of decoding pictures represented by a 25 Hz SVC HDTV Bitstream Subset with luminance resolutions as shown in table 8 and table 11 and applying up sampling to allow the decoded pictures to be displayed at full-screen size.*

5.8.2.5 Aspect Ratio Information

*For the following specification in this clause, the source aspect ratio information shall be derived from the **pic_height_in_map_units_minus1** and the **pic_width_in_mbs_minus1** and the frame cropping information coded in the sequence parameter sets and subset sequence parameter sets referenced in the VCL NAL units of a video sub-bitstream as well as the sample aspect ratio encoded with the **aspect_ratio_idc** value in the Video Usability Information of the sequence parameter sets and subset sequence parameter sets referenced in the VCL NAL units of the video sub-bitstream (see values of **aspect_ratio_idc** in ITU-T Recommendation H.264 / ISO/IEC 14496-10 [16], table E-1).*

Encoding: *The source aspect ratio shall be the same for all video sub-bitstreams of a 25 Hz SVC HDTV Bitstream Subset.*

The source aspect ratio for each video sub-bitstream, of a 25 Hz SVC HDTV Bitstream Subset, that represents pictures with one of the luminance resolutions shown in table 11 shall be 16:9.

The source aspect ratio for each video sub-bitstream, of a 25 Hz SVC HDTV Bitstream Subset, that represents pictures with one of the luminance resolutions shown in table 8 shall be either 4:3 or 16:9.

The frame cropping information in the SVC Sequence Parameter Sets may be used when appropriate.

Decoding: *25 Hz SVC HDTV IRDs shall support decoding and displaying pictures represented by 25 Hz SVC HDTV Bitstream Subsets in which each video sub-bitstream obeys the constraints for **aspect_ratio_idc** specified in table 11 or the constraints for **aspect_ratio_idc** specified in table 8 depending on the represented luminance resolution.*

25 Hz SVC HDTV IRDs shall support frame cropping.

5.8.2.6 Backwards Compatibility

Decoding: *25 Hz SVC HDTV IRDs shall be capable of decoding any bitstream that a 25 Hz H.264/AVC HDTV IRD is required to decode and resulting in the same displayed pictures as the 25 Hz H.264/AVC HDTV IRD, as described in clause 5.7.2.*

5.8.3 30 Hz SVC HDTV IRD and Bitstream

This clause specifies the 30 Hz SVC HDTV IRD and Bitstream. *All specifications in clause 5.8.1 shall apply.* The specification in the remainder of this clause only applies to the 30 Hz SVC HDTV IRD and Bitstream.

5.8.3.1 Profile and level

Encoding: *30 Hz SVC HDTV Bitstreams shall comply with the Scalable High Profile Level 4 restrictions, as specified in ITU-T Recommendation H.264 / ISO/IEC 14496-10 [16].*

*The value of **level_idc** in all sequence parameter sets and subset sequence parameter sets that are referenced in VCL NAL units of a 30 Hz SVC HDTV Bitstream Subset shall be equal to 30, 31, 32, or 40.*

30 Hz SVC HDTV Bitstreams shall conform to ITU-T Recommendation H.264 / ISO/IEC 14496-10 [16] and shall contain one or more 30 Hz SVC HDTV Bitstream Subsets. Optionally, 30 Hz SVC HDTV Bitstreams may contain additional VCL NAL units and associated non-VCL NAL units that do not belong to any 30 Hz SVC HDTV Bitstream Subset.

Decoding: *30 Hz SVC HDTV IRDs shall be capable of decoding and rendering pictures using 30 Hz SVC HDTV Bitstreams. Support for SVC Bitstreams that do not contain 30 Hz SVC HDTV Bitstream Subsets is optional.*

30 Hz SVC HDTV IRDs shall be capable of decoding and rendering pictures that are represented by 30 Hz SVC HDTV Bitstream Subsets contained in a 30 Hz SVC HDTV Bitstream. 30 Hz SVC HDTV IRDs shall be capable of discarding the VCL NAL units of a 30 Hz SVC HDTV Bitstream that do not belong to a 30 Hz SVC HDTV Bitstream Subset, before decoding and rendering pictures. Support for decoding and rendering of pictures that are represented by a SVC Bitstream Subset with a conformance point beyond the conformance point of 30 Hz SVC HDTV Bitstream Subsets is optional.

If the 30 Hz SVC HDTV IRD encounters an extension which it cannot decode, it shall discard the following data until the next start code prefix (to allow backward compatible extensions to be added in the future).

5.8.3.2 30 Hz SVC base layer bitstream

Encoding: *The SVC base layer bitstream of a 30 Hz SVC HDTV Bitstream (and a 30 Hz SVC HDTV Bitstream Subset) shall obey all constraints of a 30 Hz H.264/AVC SDTV Bitstream or all constraints of a 30 Hz H.264/AVC HDTV Bitstream.*

5.8.3.3 Frame rate

Encoding: *The frame rate of each video sub-bitstream of a 30 Hz SVC HDTV Bitstream Subset shall be 24 000/1 001, 24, 30 000/1 001, 30, 60 000/1 001 or 60 Hz. This shall be indicated in the VUI of the sequence parameter sets referenced in the VCL NAL units of the video sub-bitstream by setting **time_scale** and **num_units_in_tick** according to table 13 and the SVC VUI extension of the subset sequence parameter sets referenced in the VCL NAL units of the video sub-bitstream by setting **time_scale[i]** and **num_units_in_ticks[i]** for all present values of *i* according to table 13 with substituting **time_scale[i]** for **time_scale** and substituting **num_units_in_tick[i]** for **num_units_in_tick**. The fields **time_scale** and **num_units_in_tick** in the VUI of sequence parameter sets and the fields **time_scale[i]** and **num_units_in_ticks[i]** in the SVC VUI extension of subset sequence parameter sets define the picture rate of the video.*

The source video format for 24 000/1 001, 24, 60 000/1 001 and 60 Hz frame rate video sub-bitstreams of a 30 Hz SVC HDTV Bitstream should be progressive. The source video format for 30 000/1 001 and 30 Hz frame rate video sub-bitstreams of a 30 Hz SVC HDTV Bitstream may be interlaced or progressive.

*The frame rate of any video sub-bitstream, of a 30 Hz SVC HDTV Bitstream, with a particular value of **dependency_id** greater than 0 shall be an integer multiple of the frame rates of all video sub-bitstreams with smaller values of **dependency_id**.*

*If a 30 Hz SVC HDTV Bitstream Subset contains a video sub-bitstream with **dependency_id** equal to 1 and the source format for this video sub-bitstream is interlaced, the source video format for the video sub-bitstream with **dependency_id** equal to 0 shall also be interlaced.*

Decoding: *30 Hz SVC HDTV IRDs shall support decoding and displaying video, represented by a 30 Hz SVC HDTV Bitstream Subset, with a frame rate of 30 000/1 001, 30 Hz interlaced or progressive or 24 000/1 001, 24, 60 000/1 001 or 60 Hz progressive. Support of other frame rates is optional.*

5.8.3.4 Luminance resolution

Encoding: *Each video sub-bitstream of a 30 Hz SVC HDTV Bitstream Subset shall represent video with luminance resolutions as shown in table 10 and table 11. Non full-screen pictures may be encoded for display at less than full-size (when using one of the standard up-conversion ratios at the 30 Hz SVC HDTV IRD).*

*If a 30 Hz SVC HDTV Bitstream Subset contains a video sub-bitstream with **dependency_id** equal to 1 and this video sub-bitstream has **frame_mbs_only_flag** equal to 0, the value of **frame_mbs_only_flag** for the video sub-bitstream with **dependency_id** equal to 0 shall also be equal to 0.*

Decoding: *30 Hz SVC HDTV IRDs shall be capable of decoding pictures represented by a 30 Hz SVC HDTV Bitstream Subset with luminance resolutions as shown in table 10 and table 11 and applying up sampling to allow the decoded pictures to be displayed at full-screen size.*

5.8.3.5 Aspect Ratio Information

*For the following specification in this clause, the source aspect ratio information shall be derived from the **pic_height_in_map_units_minus1** and the **pic_width_in_mbs_minus1** and the frame cropping information coded in the sequence parameter sets and subset sequence parameter sets referenced in the VCL NAL units of a video sub-bitstream as well as the sample aspect ratio encoded with the **aspect_ratio_idc** value in the Video Usability Information of the sequence parameter sets and subset sequence parameter sets referenced in the VCL NAL units of the video sub-bitstream (see values of **aspect_ratio_idc** in ITU-T Recommendation H.264 / ISO/IEC 14496-10 [16], table E-1).*

Encoding: *The source aspect ratio shall be the same for all video sub-bitstreams of a 30 Hz SVC HDTV Bitstream Subset.*

The source aspect ratio for each video sub-bitstream, of a 30 Hz SVC HDTV Bitstream Subset, that represents pictures with one of the luminance resolutions shown in table 11 shall be 16:9.

The source aspect ratio for each video sub-bitstream, of a 30 Hz SVC HDTV Bitstream Subset, that represents pictures with one of the luminance resolutions shown in table 10 shall be either 4:3 or 16:9.

The frame cropping information in the SVC Sequence Parameter Sets may be used when appropriate.

Decoding: *30 Hz SVC HDTV IRDs shall support decoding and displaying pictures represented by 30 Hz SVC HDTV Bitstream Subsets in which each video sub-bitstream obeys the constraints for **aspect_ratio_idc** specified in table 11 or the constraints for **aspect_ratio_idc** specified in table 10 depending on the represented luminance resolution.*

30 Hz SVC HDTV IRDs shall support frame cropping.

5.8.3.6 Backwards Compatibility

Decoding: *30 Hz SVC HDTV IRDs shall be capable of decoding any bitstream that a 30 Hz H.264/AVC HDTV IRD is required to decode and resulting in the same displayed pictures as the 30 Hz H.264/AVC HDTV IRD, as described in clause 5.7.3.*

5.8.4 50 Hz SVC HDTV IRD and Bitstream

This clause specifies the 50 Hz SVC HDTV IRD and Bitstream. *All specifications in clause 5.8.1 shall apply.* The specification in the remainder of this clause only applies to the 50 Hz SVC HDTV IRD and Bitstream.

5.8.4.1 Profile and level

Encoding: *50 Hz SVC HDTV Bitstream Subsets shall comply with the Scalable High Profile Level 4.2 restrictions, as specified in ITU-T Recommendation H.264 / ISO/IEC 14496-10 [16].*

*The value of **level_idc** in all sequence parameter sets and subset sequence parameter sets that are referenced in VCL NAL units, of a 50 Hz SVC HDTV Bitstream Subset, that have **dependency_id** equal to 0 shall be equal to 30, 31, 32, or 40. The value of **level_idc** in all subset sequence parameter sets that are referenced in VCL NAL units, of a 50 Hz SVC HDTV Bitstream Subset, that have **dependency_id** equal to 1 shall be equal to 41 or 42.*

50 Hz SVC HDTV Bitstreams shall conform to ITU-T Recommendation H.264 / ISO/IEC 14496-10 [16] and shall contain one or more 50 Hz SVC HDTV Bitstream Subsets. Optionally, 50 Hz SVC HDTV Bitstreams may contain additional VCL NAL units and associated non-VCL NAL units that do not belong to any 50 Hz SVC HDTV Bitstream Subset.

Decoding: *50 Hz SVC HDTV IRDs shall be capable of decoding and rendering pictures using 50 Hz SVC HDTV Bitstreams. Support for SVC Bitstreams that do not contain 50 Hz SVC HDTV Bitstream Subsets is optional.*

50 Hz SVC HDTV IRDs shall be capable of decoding and rendering pictures that are represented by 50 Hz SVC HDTV Bitstream Subsets contained in a 50 Hz SVC HDTV Bitstream. 50 Hz SVC HDTV IRDs shall be capable of discarding the VCL NAL units of a 50 Hz SVC HDTV Bitstream that do not belong to a 50 Hz SVC HDTV Bitstream Subset, before decoding and rendering pictures. Support for decoding and rendering of pictures that are represented by a SVC Bitstream Subset with a conformance point beyond the conformance point of 50 Hz SVC HDTV Bitstream Subsets is optional.

If the 50 Hz SVC HDTV IRD encounters an extension which it cannot decode, it shall discard the following data until the next start code prefix (to allow backward compatible extensions to be added in the future).

5.8.4.2 50 Hz SVC base layer bitstream

Encoding: *The SVC base layer bitstream of a 50 Hz SVC HDTV Bitstream (and a 50 Hz SVC HDTV Bitstream Subset) shall obey all constraints of a 25 Hz H.264/AVC SDTV Bitstream or all constraints of a 25 Hz H.264/AVC HDTV Bitstream.*

5.8.4.3 Frame rate

Encoding: *The frame rate of each video sub-bitstream of a 50 Hz SVC HDTV Bitstream Subset shall be 25 Hz or 50 Hz. This shall be indicated in the VUI of the sequence parameter sets referenced in the VCL NAL units of the video sub-bitstream by setting `time_scale` and `num_units_in_tick` according to table 12 and the SVC VUI extension of the subset sequence parameter sets referenced in the VCL NAL units of the video sub-bitstream by setting `time_scale[i]` and `num_units_in_tick[i]` for all present values of `i` according to table 12 with substituting `time_scale[i]` for `time_scale` and substituting `num_units_in_tick[i]` for `num_units_in_tick`. The fields `time_scale` and `num_units_in_tick` in the VUI of sequence parameter sets and the fields `time_scale[i]` and `num_units_in_tick[i]` in the SVC VUI extension of subset sequence parameter sets define the picture rate of the video.*

The source video format for 50 Hz frame rate video sub-bitstreams of a 50 Hz SVC HDTV Bitstream should be progressive. The source video format for 25 Hz frame rate video sub-bitstreams of a 50 Hz SVC HDTV Bitstream may be interlaced or progressive.

If a 50 Hz SVC HDTV Bitstream Subset contains a video sub-bitstream with `dependency_id` equal to 1, the source video format for this video sub-bitstream shall be progressive.

The frame rate of any video sub-bitstream, of a 50 Hz SVC HDTV Bitstream, with a particular value of `dependency_id` greater than 0 shall be an integer multiple of the frame rates of all video sub-bitstreams with smaller values of `dependency_id`.

Decoding: *50 Hz SVC HDTV IRDs shall support decoding and displaying video, represented by a 50 Hz SVC HDTV Bitstream Subset, with a frame rate of 25 Hz interlaced or progressive, or 50 Hz progressive. Support of other frame rates is optional.*

5.8.4.4 Luminance resolution

Encoding: *Each video sub-bitstream of a 50 Hz SVC HDTV Bitstream Subset shall represent video with luminance resolutions as shown in table 11. Non full-screen pictures may be encoded for display at less than full-size (when using one of the standard up-conversion ratios at the 50 Hz SVC HDTV IRD).*

If a 50 Hz SVC HDTV Bitstream Subset contains a video sub-bitstream with `dependency_id` equal to 1, the field `frame_mbs_only_flag` shall be equal to 1 for this video sub-bitstream.

*If a 50 Hz SVC HDTV Bitstream Subset contains a video sub-bitstream with `dependency_id` equal to 1 and the field `frame_mbs_only_flag` for the video sub-bitstream with `dependency_id` equal to 0 is equal to 0, the fields `pic_height_in_map_units_minus1`, `frame_crop_top_offset` and `frame_crop_bottom_offset` for the video sub-bitstream with `dependency_id` equal to 1 shall be equal to $2 * (picHeightInMapUnitsMinus1DIId0 + 1) - 1$, $2 * frameCropTopOffsetDIId0$ and $2 * frameCropBottomOffsetDIId0$, respectively, with `picHeightInMapUnitsMinus1DIId0`, `frameCropTopOffsetDIId0` and `frameCropBottomOffsetDIId0` being the values of the fields `pic_height_in_map_units_minus1`, `frame_crop_top_offset` and `frame_crop_bottom_offset`, respectively, for the video sub-bitstream with `dependency_id` equal to 0.*

NOTE: Scalability from an interlaced base layer (with `frame_mbs_only_flag` equal to 0) to a progressive enhancement layer (with `frame_mbs_only_flag` equal to 1) is only supported when the vertical luminance resolution is the same in both layers.

Decoding: *50 Hz SVC HDTV IRDs shall be capable of decoding pictures represented by a 50 Hz SVC HDTV Bitstream Subset with luminance resolutions as shown in table 11 and applying up sampling to allow the decoded pictures to be displayed at full-screen size.*

5.8.4.5 Aspect Ratio Information

For the following specification in this clause, the source aspect ratio information shall be derived from the *pic_height_in_map_units_minus1* and the *pic_width_in_mbs_minus1* and the frame cropping information coded in the sequence parameter sets and subset sequence parameter sets referenced in the VCL NAL units of a video sub-bitstream as well as the sample aspect ratio encoded with the *aspect_ratio_idc* value in the Video Usability Information of the sequence parameter sets and subset sequence parameter sets referenced in the VCL NAL units of the video sub-bitstream (see values of *aspect_ratio_idc* in ITU-T Recommendation H.264 / ISO/IEC 14496-10 [16], table E-1).

Encoding: The source aspect ratio for each video sub-bitstream of a 50 Hz SVC HDTV Bitstream Subset shall be 16:9.

The frame cropping information in the SVC Sequence Parameter Sets may be used when appropriate.

Decoding: 50 Hz SVC HDTV IRDs shall support decoding and displaying pictures represented by 50 Hz SVC HDTV Bitstream Subsets in which each video sub-bitstream obeys the constraints for *aspect_ratio_idc* specified in table 11.

50 Hz SVC HDTV IRDs shall support frame cropping.

5.8.4.6 Backwards Compatibility

Decoding: 50 Hz SVC HDTV IRDs shall be capable of decoding any bitstream that a 50 Hz H.264/AVC HDTV IRD is required to decode and resulting in the same displayed pictures as the 50 Hz H.264/AVC HDTV IRD, as described in clause 5.7.4.

5.8.5 60 Hz SVC HDTV IRD and Bitstream

This clause specifies the 60 Hz SVC HDTV IRD and Bitstream. All specifications in clause 5.8.1 shall apply. The specification in the remainder of this clause only applies to the 60 Hz SVC HDTV IRD and Bitstream.

5.8.5.1 Profile and level

Encoding: 60 Hz SVC HDTV Bitstream Subsets shall comply with the Scalable High Profile Level 4.2 restrictions, as specified in ITU-T Recommendation H.264 / ISO/IEC 14496-10 [16].

The value of *level_idc* in all sequence parameter sets and subset sequence parameter sets that are referenced in VCL NAL units, of a 60 Hz SVC HDTV Bitstream Subset, that have *dependency_id* equal to 0 shall be equal to 30, 31, 32, or 40. The value of *level_idc* in all subset sequence parameter sets that are referenced in VCL NAL units, of a 60 Hz SVC HDTV Bitstream Subset, that have *dependency_id* equal to 1 shall be equal to 41 or 42.

60 Hz SVC HDTV Bitstreams shall conform to ITU-T Recommendation H.264 / ISO/IEC 14496-10 [16] and shall contain one or more 60 Hz SVC HDTV Bitstream Subsets. Optionally, 60 Hz SVC HDTV Bitstreams may contain additional VCL NAL units and associated non-VCL NAL units that do not belong to any 60 Hz SVC HDTV Bitstream Subset.

Decoding: 60 Hz SVC HDTV IRDs shall be capable of decoding and rendering pictures using 60 Hz SVC HDTV Bitstreams. Support for SVC Bitstreams that do not contain 60 Hz SVC HDTV Bitstream Subsets is optional.

60 Hz SVC HDTV IRDs shall be capable of decoding and rendering pictures that are represented by 60 Hz SVC HDTV Bitstream Subsets contained in a 60 Hz SVC HDTV Bitstream. 60 Hz SVC HDTV IRDs shall be capable of discarding the VCL NAL units of a 60 Hz SVC HDTV Bitstream that do not belong to a 60 Hz SVC HDTV Bitstream Subset, before decoding and rendering pictures. Support for decoding and rendering of pictures that are represented by a SVC Bitstream Subset with a conformance point beyond the conformance point of 60 Hz SVC HDTV Bitstream Subsets is optional.

If the 60 Hz SVC HDTV IRD encounters an extension which it cannot decode, it shall discard the following data until the next start code prefix (to allow backward compatible extensions to be added in the future).

5.8.5.2 60 Hz SVC base layer bitstream

Encoding: *The SVC base layer bitstream of a 60 Hz SVC HDTV Bitstream (and a 60 Hz SVC HDTV Bitstream Subset) shall obey all constraints of a 30 Hz H.264/AVC SDTV Bitstream or all constraints of a 30 Hz H.264/AVC HDTV Bitstream.*

5.8.5.3 Frame rate

Encoding: *The frame rate of each video sub-bitstream of a 60 Hz SVC HDTV Bitstream Subset shall be 24 000/1 001, 24, 30 000/1 001, 30, 60 000/1 001 or 60 Hz. This shall be indicated in the VUI of the sequence parameter sets referenced in the VCL NAL units of the video sub-bitstream by setting **time_scale** and **num_units_in_tick** according to table 13 and the SVC VUI extension of the subset sequence parameter sets referenced in the VCL NAL units of the video sub-bitstream by setting **time_scale[i]** and **num_units_in_tick[i]** according to table 13 with substituting **time_scale[i]** for **time_scale** and substituting **num_units_in_tick[i]** for **num_units_in_tick**. The fields **time_scale** and **num_units_in_tick** in the VUI of sequence parameter sets and the fields **time_scale[i]** and **num_units_in_tick[i]** in the SVC VUI extension of subset sequence parameter sets define the picture rate of the video.*

The source video format for 24 000/1 001, 24, 60 000/1 001 and 60 Hz frame rate video sub-bitstreams of a 60 Hz SVC HDTV Bitstream should be progressive. The source video format for 30 000/1 001 and 30 Hz frame rate video sub-bitstreams of a 60 Hz SVC HDTV Bitstream may be interlaced or progressive.

*If a 60 Hz SVC HDTV Bitstream Subset contains a video sub-bitstream with **dependency_id** equal to 1, the source video format for this video sub-bitstream shall be progressive.*

*The frame rate of any video sub-bitstream, of a 60 Hz SVC HDTV Bitstream, with a particular value of **dependency_id** greater than 0 shall be an integer multiple of the frame rates of all video sub-bitstreams with smaller values of **dependency_id**.*

Decoding: *60 Hz SVC HDTV IRDs shall support decoding and displaying video, represented by a 60 Hz SVC HDTV Bitstream Subset, with a frame rate of 30 000/1 001, 30 Hz interlaced or progressive or 24 000/1 001, 24, 60 000/1 001 or 60 Hz progressive. Support of other frame rates is optional.*

5.8.5.4 Luminance resolution

Encoding: *Each video sub-bitstream of a 60 Hz SVC HDTV Bitstream Subset shall represent video with luminance resolutions as shown in table 11. Non full-screen pictures may be encoded for display at less than full-size (when using one of the standard up-conversion ratios at the 60 Hz SVC HDTV IRD).*

*If a 60 Hz SVC HDTV Bitstream Subset contains a video sub-bitstream with **dependency_id** equal to 1, the field **frame_mbs_only_flag** shall be equal to 1 for this video sub-bitstream.*

*If a 60 Hz SVC HDTV Bitstream Subset contains a video sub-bitstream with **dependency_id** equal to 1 and the field **frame_mbs_only_flag** for the video sub-bitstream with **dependency_id** equal to 0 is equal to 0, the fields **pic_height_in_map_units_minus1**, **frame_crop_top_offset** and **frame_crop_bottom_offset** for the video sub-bitstream with **dependency_id** equal to 1 shall be equal to $2 * (picHeightInMapUnitsMinus1DId0 + 1) - 1$, $2 * frameCropTopOffsetDId0$ and $2 * frameCropBottomOffsetDId0$, respectively, with **picHeightInMapUnitsMinus1DId0**, **frameCropTopOffsetDId0** and **frameCropBottomOffsetDId0** being the values of the fields **pic_height_in_map_units_minus1**, **frame_crop_top_offset** and **frame_crop_bottom_offset**, respectively, for the video sub-bitstream with **dependency_id** equal to 0.*

NOTE: Scalability from an interlaced base layer (with `frame_mbs_only_flag` equal to 0) to a progressive enhancement layer (with `frame_mbs_only_flag` equal to 1) is only supported when the vertical luminance resolution is the same in both layers.

Decoding: 60 Hz SVC HDTV IRDs shall be capable of decoding pictures represented by a 60 Hz SVC HDTV Bitstream Subset with luminance resolutions as shown in table 11 and applying up sampling to allow the decoded pictures to be displayed at full-screen size.

5.8.5.5 Aspect Ratio Information

For the following specification in this clause, the source aspect ratio information shall be derived from the `pic_height_in_map_units_minus1` and the `pic_width_in_mbs_minus1` and the frame cropping information coded in the sequence parameter sets and subset sequence parameter sets referenced in the VCL NAL units of a video sub-bitstream as well as the sample aspect ratio encoded with the `aspect_ratio_idc` value in the Video Usability Information of the sequence parameter sets and subset sequence parameter sets referenced in the VCL NAL units of the video sub-bitstream (see values of `aspect_ratio_idc` in ITU-T Recommendation H.264 / ISO/IEC 14496-10 [16], table E-1).

Encoding: The source aspect ratio for each video sub-bitstream of a 60 Hz SVC HDTV Bitstream Subset shall be 16:9.

The frame cropping information in the SVC Sequence Parameter Sets may be used when appropriate.

Decoding: 60 Hz SVC HDTV IRDs shall support decoding and displaying pictures represented by 60 Hz SVC HDTV Bitstream Subsets in which each video sub-bitstream obeys the constraints for `aspect_ratio_idc` specified in table 11.

60 Hz SVC HDTV IRDs shall support frame cropping.

5.8.5.6 Backwards Compatibility

Decoding: 60 Hz SVC HDTV IRDs shall be capable of decoding any bitstream that a 60 Hz H.264/AVC HDTV IRD is required to decode and resulting in the same displayed pictures as the 60 Hz H.264/AVC HDTV IRD, as described in clause 5.7.5.

5.9 25 Hz VC-1 SDTV IRDs and Bitstreams

The video encoding and video decoding shall conform to SMPTE ST 421 [20]. Some of the parameters and fields are not used in the DVB System and these restrictions are described below. The VC-1 IRD design shall be made under the assumption that any legal structure as permitted by SMPTE ST 421 [20] and the restrictions that are specified for the VC-1 IRDs may occur in the broadcast stream even if presently reserved or unused.

5.9.1 Profile, Level and Colour Difference Format

Encoding: 25 Hz VC-1 SDTV Bitstreams shall comply with the restrictions described in SMPTE ST 421 [20] for Advanced Profile at Level 1.

The value of **PROFILE** shall be equal to '11' indicating Advanced Profile. The value of **LEVEL** shall be equal to '001' indicating Level 1 or, if appropriate, '000' indicating Level 0.

Decoding: 25 Hz VC-1 SDTV IRDs shall support decoding and displaying of Advanced Profile bitstreams at Level 1 using 4:2:0 colour difference format. Support of levels beyond Level 1 is optional. If the VC-1 IRD encounters an extension which it cannot decode, it shall discard the following data until the next start code prefix (to allow backward compatible extensions to be added in the future).

5.9.2 Frame rate

- Encoding: *The frame rate in 25 Hz VC-1 SDTV Bitstreams shall be 25 Hz. This shall be indicated by setting **FRAMERATENR** to 2 and **FRAMERATEDR** to 1.*
- Decoding: *25 Hz VC-1 SDTV IRDs shall support decoding and displaying video with a frame rate of 25 Hz within the constraints of Advanced Profile at Level 1. Support of other frame rates is optional.*

5.9.3 Aspect ratio

- Encoding: *The source aspect ratio in 25 Hz VC-1 SDTV Bitstreams shall be either 4:3 or 16:9. The display geometry information to optimally render the decoded picture shall be signalled by an appropriate combination of **DISP_HORIZ_SIZE**, **DISP_VERT_SIZE**, **ASPECT_RATIO**, **ASPECT_HORIZ_SIZE** and **ASPECT_VERT_SIZE**.*
- Decoding: *25 Hz VC-1 SDTV IRDs shall support decoding and displaying 25 Hz VC-1 SDTV Bitstreams with source aspect ratios of either 4:3 or 16:9. It is recommended that the display process use the display geometry information signalled by **DISP_HORIZ_SIZE**, **DISP_VERT_SIZE**, **ASPECT_RATIO**, **ASPECT_HORIZ_SIZE** and **ASPECT_VERT_SIZE** to optimally render the decoded picture.*

5.9.4 Luminance resolution

- Encoding: *25 Hz VC-1 SDTV Bitstreams shall represent coded video with luminance resolutions as shown in table 14. Non full-screen pictures may be encoded for display at less than full-size, when using one of the standard up-conversion ratios at the 25 Hz VC-1 SDTV IRD (e.g. a horizontal resolution of 704 pixels within the 720 pixels full-screen display).*
- Decoding: *25 Hz VC-1 SDTV IRDs shall be capable of decoding pictures with luminance resolutions as shown in table 14 and applying up sampling to allow the decoded pictures to be displayed at full-screen size. In addition, 25 Hz VC-1 SDTV IRDs shall be capable of decoding lower picture resolutions and displaying them at less than full-size after using one of the standard up-conversions, e.g. a horizontal resolution of 704 pixels within the 720 pixels full-screen display.*

Table 14: Resolutions for Full-screen Display from 25 Hz VC-1 SDTV IRD

Coded Picture		Displayed Picture Horizontal up sampling	
Luminance resolution (horizontal x vertical)	Source Video Aspect Ratio	4:3 Monitors	16:9 Monitors
720 x 576	4:3 16:9	x 1 x 4/3 (see note 2)	x 3/4 (see note 1) x 1
544 x 576	4:3 16:9	x 4/3 x 16/9 (see note 2)	x 1 (see note 1) x 4/3
480 x 576	4:3 16:9	x 3/2 x 2 (see note 2)	x 9/8 (see note 1) x 3/2
352 x 576	4:3 16:9	x 2 x 8/3 (see note 2)	x 3/2 (see note 1) x 2
352 x 288	4:3 16:9	x 2 x 8/3 (see note 2) (and vertical up sampling x 2)	x 3/2 (see note 1) x 2 (and vertical up sampling x 2)

NOTE 1: Up sampling of 4:3 pictures for display on a 16:9 monitor is optional in the IRD, as 16:9 monitors can be switched to operate in 4:3 mode.

NOTE 2: The up sampling with this value is applied to the pixels of the 16:9 picture to be displayed on a 4:3 monitor.

NOTE 3: It is recommended that luminance resolution of 704 pixels represents the "middle" of the picture, and that it be decoded to a 720 pixels full-screen display by placing 8 pixels of padding at each side. It is recommended that luminance resolutions, such as 352 pixels, that are natural scalings of 704 pixels, be upscaled to 704 pixels and padded as above. It is recommended that all other resolutions be scaled as indicated by the table above. Where this does not result in the expected 720 pixels full-screen display, it is recommended that the result of the scaling be clipped or padded symmetrically as required to produce a 720 pixels full-screen display.

5.9.5 Colour Parameter Information

Encoding: *The chromaticity co-ordinates of the ideal display, opto-electronic transfer characteristic of the source picture and matrix coefficients used in deriving luminance and chrominance signals from the red, green and blue primaries shall be explicitly signalled in the encoded 25 Hz VC-1 SDTV Bitstream by setting the appropriate values for each of the following 3 parameters: **COLOR_PRIM**, **TRANSFER_CHAR** and **MATRIX_COEFF**.*

It is recommended that ITU-R Recommendation BT.1700 Part B [25] colorimetry is used in the 25 Hz VC-1 SDTV bitstream, which is signalled by setting **COLOR_PRIM** to the value 5, **TRANSFER_CHAR** to the value 5 and **MATRIX_COEFF** to the value 6.

Decoding: *25 Hz VC-1 SDTV IRDs shall support decoding bitstreams with any allowed values of **COLOR_PRIM**, **TRANSFER_CHAR** and **MATRIX_COEFF**. It is recommended that appropriate processing be included for the accurate representation of pictures using ITU-R Recommendation BT.1700 Part B [25] colorimetry.*

NOTE: Previous editions of the present document referenced ITU-R Recommendation BT.470 System B, G colorimetry [i.4]. ITU-R Recommendation BT.1700 [25] replaces ITU-R Recommendation BT. 470 [i.4].

5.9.6 Random Access Point

Encoding: Where channel change times are important it is recommended that a Sequence Header and Entry-Point Header are encoded at least once every 500 ms. In applications where channel change time is an issue but coding efficiency is critical, it is recommended that a Sequence Header and Entry-Point Header are encoded at least once every 2 s. For those applications where channel change time is not an issue, it is recommended that a Sequence Header and Entry-Point Header are sent at least once every 5 s.

NOTE 1: Increasing the frequency of Sequence Header and Entry-Point Header will reduce channel hopping time but will reduce the efficiency of the video compression.

NOTE 2: Having a regular interval between Entry-Point Headers may improve trick mode performance, but may reduce the efficiency of the video compression.

NOTE 3: The AU_information_descriptor described in annex D provides a means of signalling information about Random Access Points that may be used by some applications, and it is recommended that this is present.

5.10 25 Hz VC-1 HDTV IRDs and Bitstreams

The video encoding and video decoding shall conform to SMPTE ST 421 [20]. Some of the parameters and fields are not used in the DVB System and these restrictions are described below. The VC-1 IRD design shall be made under the assumption that any legal structure as permitted by SMPTE ST 421 [20] and the restrictions that are specified for the VC-1 IRDs may occur in the broadcast stream even if presently reserved or unused.

5.10.1 Profile, Level and Colour Difference Format

Encoding: *25 Hz VC-1 HDTV Bitstreams shall comply with the restrictions described in SMPTE ST 421 [20] for Advanced Profile at Level 3.*

*The value of **PROFILE** shall be equal to '11' indicating Advanced Profile. The value of **LEVEL** shall be equal to '011' indicating Level 3 or, if appropriate, '010' indicating Level 2, '001' indicating Level 1 or '000' indicating Level 0.*

Decoding: *25 Hz VC-1 HDTV IRDs shall support decoding and displaying of Advanced Profile bitstreams at Level 3 using 4:2:0 colour difference format. Support of levels beyond Level 3 is optional. If the VC-1 IRD encounters an extension which it cannot decode, it shall discard the following data until the next start code prefix (to allow backward compatible extensions to be added in the future).*

5.10.2 Frame rate

- Encoding: *The frame rate in 25 Hz VC-1 HDTV Bitstreams shall be 25 Hz or 50 Hz. This shall be indicated by setting **FRAMERATENR** to 2 or 4, as appropriate, and **FRAMERATEDR** to 1.*
- Decoding: *25 Hz VC-1 HDTV IRDs shall support decoding and displaying video with a frame rate of 25 Hz or 50 Hz within the constraints of Advanced Profile at Level 3. Support of other frame rates is optional.*

5.10.3 Aspect ratio

- Encoding: *The source aspect ratio in 25 Hz VC-1 HDTV Bitstreams shall be 16:9. The display geometry information to optimally render the decoded picture shall be signalled by an appropriate combination of **DISP_HORIZ_SIZE**, **DISP_VERT_SIZE**, **ASPECT_RATIO**, **ASPECT_HORIZ_SIZE** and **ASPECT_VERT_SIZE**.*
- Decoding: *25 Hz VC-1 HDTV IRDs shall support decoding and displaying 25 Hz VC-1 HDTV Bitstreams with source aspect ratios of 16:9. It is recommended that the display process use the display geometry information signalled by **DISP_HORIZ_SIZE**, **DISP_VERT_SIZE**, **ASPECT_RATIO**, **ASPECT_HORIZ_SIZE** and **ASPECT_VERT_SIZE** to optimally render the decoded picture.*

5.10.4 Luminance resolution

- Encoding: *25 Hz VC-1 HDTV Bitstreams shall represent video with luminance resolutions as shown in table 15. Non full-screen pictures may be encoded for display at less than full-size (when using one of the standard up-conversion ratios at the 25 Hz VC-1 HDTV IRD).*
- Decoding: *25 Hz VC-1 HDTV IRDs shall be capable of decoding pictures with luminance resolutions as shown in table 15 and applying up sampling to allow the decoded pictures to be displayed at full-screen size.*

Table 15: Resolutions for Full-screen Display from 25 Hz VC-1 HDTV IRD

Luminance resolution (horizontal x vertical)	Coded Picture	
	Source Aspect Ratio	16:9 Monitors Horizontal up sampling
1 920 x 1 080	16:9	x 1
1 440 x 1 080	16:9	x 4/3
1 280 x 1 080	16:9	x 3/2
960 x 1 080	16:9	x 2
1 280 x 720	16:9	x 1
960 x 720	16:9	x 4/3
640 x 720	16:9	x 2

5.10.5 Colour Parameter Information

- Encoding: *The chromaticity co-ordinates of the ideal display, opto-electronic transfer characteristic of the source picture and matrix coefficients used in deriving luminance and chrominance signals from the red, green and blue primaries shall be explicitly signalled in the encoded 25 Hz VC-1 HDTV Bitstream by setting the appropriate values for each of the following 3 parameters: **COLOR_PRIM**, **TRANSFER_CHAR** and **MATRIX_COEFF**.*

It is recommended that ITU-R Recommendation BT.709 [13] colorimetry is used for all 25 Hz VC-1 HDTV Bitstreams, which is signalled by setting **COLOR_PRIM** to the value 1, **TRANSFER_CHAR** to the value 1 and **MATRIX_COEFF** to the value 1.

- Decoding: *25 Hz VC-1 HDTV IRDs shall support decoding bitstreams with any allowed values of **COLOR_PRIM**, **TRANSFER_CHAR** and **MATRIX_COEFF**. It is recommended that appropriate processing be included for the accurate representation of pictures using ITU-R Recommendation BT.709 [13] colorimetry.*

5.10.6 Random Access Point

Encoding: Where channel change times are important it is recommended that a Sequence Header and Entry-Point Header are encoded at least once every 500 ms. In applications where channel change time is an issue but coding efficiency is critical, it is recommended that a Sequence Header and Entry-Point Header are encoded at least once every 2 s. For those applications where channel change time is not an issue, it is recommended that a Sequence Header and Entry-Point Header are sent at least once every 5 s.

NOTE 1: Increasing the frequency of Sequence Header and Entry-Point Header will reduce channel hopping time but will reduce the efficiency of the video compression.

NOTE 2: Having a regular interval between Entry-Point Headers may improve trick mode performance, but may reduce the efficiency of the video compression.

NOTE 3: The AU_information_descriptor described in annex D provides a means of signalling information about Random Access Points that may be used by some applications, and it is recommended that this is present.

5.10.7 Backwards Compatibility

Decoding: 25 Hz VC-1 HDTV IRDs shall be capable of decoding any bitstream that a 25 Hz VC-1 SDTV IRD is required to decode and resulting in the same displayed pictures as the 25 Hz VC-1 SDTV IRD.

5.11 30 Hz VC-1 SDTV IRDs and Bitstreams

The video encoding and video decoding shall conform to SMPTE ST 421 [20]. Some of the parameters and fields are not used in the DVB System and these restrictions are described below. The VC-1 IRD design shall be made under the assumption that any legal structure as permitted by SMPTE ST 421 [20] and the restrictions that are specified for the VC-1 IRDs may occur in the broadcast stream even if presently reserved or unused.

5.11.1 Profile and level

Encoding: 30 Hz VC-1 SDTV Bitstreams shall comply with the restrictions described in SMPTE ST 421 [20] for Advanced Profile at Level 1.

The value of **PROFILE** shall be equal to '11' indicating Advanced Profile. The value of **LEVEL** shall be equal to '001' indicating Level 1 or, if appropriate, '000' indicating Level 0.

Decoding: 30 Hz VC-1 SDTV IRDs shall support decoding and displaying of Advanced Profile bitstreams at Level 1 using 4:2:0 colour difference format. Support of levels beyond Level 1 is optional. If the VC-1 IRD encounters an extension which it cannot decode, it shall discard the following data until the next start code prefix (to allow backward compatible extensions to be added in the future).

5.11.2 Frame rate

Encoding: The frame rate in 30 Hz VC-1 SDTV Bitstreams shall be 24 000/1 001, 24, 30 000/1 0001 or 30 Hz. This shall be indicated by setting **FRAMERATENR** to 1 or 3 and **FRAMERATEDR** to 1 or 2, as appropriate.

Decoding: 30 Hz VC-1 SDTV IRDs shall support decoding and displaying video with a frame rates of 24 000/1 001, 24, 30 000/1 0001 or 30 Hz within the constraints of Advanced Profile at Level 1. Support of other frame rates is optional.

5.11.3 Aspect ratio

Encoding: The source aspect ratio in 30 Hz VC-1 SDTV Bitstreams shall be either 4:3 or 16:9. The display geometry information to optimally render the decoded picture shall be signalled by an appropriate combination of **DISP_HORIZ_SIZE**, **DISP_VERT_SIZE**, **ASPECT_RATIO**, **ASPECT_HORIZ_SIZE** and **ASPECT_VERT_SIZE**.

Decoding: *30 Hz VC-1 SDTV IRDs shall support decoding and displaying 30 Hz VC-1 SDTV Bitstreams with source aspect ratios of either 4:3 or 16:9. It is recommended that the display process use the display geometry information signalled by **DISP_HORIZ_SIZE**, **DISP_VERT_SIZE**, **ASPECT_RATIO**, **ASPECT_HORIZ_SIZE** and **ASPECT_VERT_SIZE** to optimally render the decoded picture.*

5.11.4 Luminance resolution

Encoding: *30 Hz VC-1 SDTV Bitstreams shall represent coded video with luminance resolutions as shown in table 16. Non full-screen pictures may be encoded for display at less than full-size, when using one of the standard up-conversion ratios at the 30 Hz VC-1 SDTV IRD (e.g. a horizontal resolution of 704 pixels within the 720 pixels full-screen display).*

Decoding: *30 Hz VC-1 SDTV IRDs shall be capable of decoding pictures with luminance resolutions as shown in table 16 and applying up sampling to allow the decoded pictures to be displayed at full-screen size. In addition, 30 Hz VC-1 SDTV IRDs shall be capable of decoding lower picture resolutions and displaying them at less than full-size after using one of the standard up-conversions, e.g. a horizontal resolution of 704 pixels within the 720 pixels full-screen display.*

Table 16: Resolutions for Full-screen Display from 30 Hz VC-1 SDTV IRD

Coded Picture		Displayed Picture Horizontal up sampling	
Luminance resolution (horizontal x vertical)	Source Video Aspect Ratio	4:3 Monitors	16:9 Monitors
720 x 480	4:3 16:9	x 1 x 4/3 (see note 2)	x 3/4 (see note 1) x 1
640 x 480	4:3 16:9	x 9/8 x 3/2	x 27/32 (see note 1) x 9/8
544 x 480	4:3 16:9	x 4/3 x 16/9 (see note 2)	x 1 (see note 1) x 4/3
480 x 480	4:3 16:9	x 3/2 x 2 (see note 2)	x 9/8 (see note 1) x 3/2
352 x 480	4:3 16:9	x 2 x 8/3 (see note 2)	x 3/2 (see note 1) x 2
352 x 240	4:3 16:9	x 2 x 8/3 (see note 2) (and vertical up sampling x 2)	x 3/2 (see note 1) x 2 (and vertical up sampling x 2)

NOTE 1: Up sampling of 4:3 pictures for display on a 16:9 monitor is optional in the IRD, as 16:9 monitors can be switched to operate in 4:3 mode.

NOTE 2: The up sampling with this value is applied to the pixels of the 16:9 picture to be displayed on a 4:3 monitor.

NOTE 3: It is recommended that luminance resolution of 704 pixels represents the "middle" of the picture, and that it be decoded to a 720 pixels full-screen display by placing 8 pixels of padding at each side. It is recommended that luminance resolutions, such as 352 pixels, that are natural scalings of 704 pixels, be upsampled to 704 pixels and padded as above. It is recommended that all other resolutions be scaled as indicated by the table above. Where this does not result in the expected 720 pixels full-screen display, it is recommended that the result of the scaling be clipped or padded symmetrically as required to produce a 720 pixels full-screen display.

5.11.5 Colour Parameter Information

Encoding: *The chromaticity co-ordinates of the ideal display, opto-electronic transfer characteristic of the source picture and matrix coefficients used in deriving luminance and chrominance signals from the red, green and blue primaries shall be explicitly signalled in the encoded 30 Hz VC-1 SDTV Bitstream by setting the appropriate values for each of the following 3 parameters: **COLOR_PRIM**, **TRANSFER_CHAR** and **MATRIX_COEFF**.*

It is recommended that ITU-R Recommendation BT.1700 Part A [25] colorimetry is used for 30 Hz VC-1 SDTV bitstreams, which is signalled by setting **COLOR_PRIM** to the value 6, **TRANSFER_CHAR** to the value 6 and **MATRIX_COEFF** to the value 6.

Decoding: *30 Hz VC-1 SDTV IRDs shall support decoding bitstreams with any allowed values of **COLOR_PRIM**, **TRANSFER_CHAR** and **MATRIX_COEFF**. It is recommended that appropriate processing be included for the accurate representation of pictures using ITU-R Recommendation BT.1700 Part A [25] colorimetry.*

NOTE: Previous editions of the present document referenced SMPTE ST 170 colorimetry [i.9]. ITU-R Recommendation BT.1700 Part A [25] references SMPTE ST 170.

5.11.6 Random Access Point

Encoding: Where channel change times are important it is recommended that a Sequence Header and Entry-Point Header are encoded at least once every 500 ms. In applications where channel change time is an issue but coding efficiency is critical, it is recommended that a Sequence Header and Entry-Point Header are encoded at least once every 2 s. For those applications where channel change time is not an issue, it is recommended that a Sequence Header and Entry-Point Header are sent at least once every 5 s.

NOTE 1: Increasing the frequency of Sequence Header and Entry-Point Header will reduce channel hopping time but will reduce the efficiency of the video compression.

NOTE 2: Having a regular interval between Entry-Point Headers may improve trick mode performance, but may reduce the efficiency of the video compression.

NOTE 3: The AU_information_descriptor described in annex D provides a means of signalling information about Random Access Points that may be used by some applications, and it is recommended that this is present.

5.12 30 Hz VC-1 HDTV IRDs and Bitstreams

The video encoding and video decoding shall conform to SMPTE ST 421 [20]. Some of the parameters and fields are not used in the DVB System and these restrictions are described below. The VC-1 IRD design shall be made under the assumption that any legal structure as permitted by SMPTE ST 421 [20] and the restrictions that are specified for the VC-1 IRDs may occur in the broadcast stream even if presently reserved or unused.

5.12.1 Profile, Level and Colour Difference Format

Encoding: *30 Hz VC-1 HDTV Bitstreams shall comply with the restrictions described in SMPTE ST 421 [20] for Advanced Profile at Level 3.*

*The value of **PROFILE** shall be equal to '11' indicating Advanced Profile. The value of **LEVEL** shall be equal to '011' indicating Level 3 or, if appropriate, '010' indicating Level 2, '001' indicating Level 1 or '000' indicating Level 0.*

Decoding: *30 Hz VC-1 HDTV IRDs shall support decoding and displaying of Advanced Profile bitstreams at Level 3 using 4:2:0 colour difference format. Support of levels beyond Level 3 is optional. If the VC-1 IRD encounters an extension which it cannot decode, it shall discard the following data until the next start code prefix (to allow backward compatible extensions to be added in the future).*

5.12.2 Frame rate

Encoding: *The frame rate in 30 Hz VC-1 HDTV Bitstreams shall be 24 000/1 001, 24, 30 000/1 0001, 30, 60 000/1 000 or 60 Hz. This shall be indicated by setting **FRAMERATENR** to 1, 3 or 5 and **FRAMERATEDR** to 1 or 2, as appropriate.*

Decoding: *30 Hz VC-1 HDTV IRDs shall support decoding and displaying video with a frame rate of 24 000/1 001, 24, 30 000/1 0001, 30, 60 000/1 000 or 60 Hz within the constraints of Advanced Profile at Level 3. Support of other frame rates is optional.*

5.12.3 Aspect ratio

Encoding: *The source aspect ratio in 30 Hz VC-1 HDTV Bitstreams shall be 16:9. The display geometry information to optimally render the decoded picture shall be signalled by an appropriate combination of **DISP_HORIZ_SIZE**, **DISP_VERT_SIZE**, **ASPECT_RATIO**, **ASPECT_HORIZ_SIZE** and **ASPECT_VERT_SIZE**.*

Decoding: *30 Hz VC-1 HDTV IRDs shall support decoding and displaying 30 Hz VC-1 HDTV Bitstreams with source aspect ratios of 16:9. It is recommended that the display process use the display geometry information signalled by **DISP_HORIZ_SIZE**, **DISP_VERT_SIZE**, **ASPECT_RATIO**, **ASPECT_HORIZ_SIZE** and **ASPECT_VERT_SIZE** to optimally render the decoded picture.*

5.12.4 Luminance resolution

Encoding: *30 Hz VC-1 HDTV Bitstreams shall represent video with luminance resolutions as shown in table 17. Non full-screen pictures may be encoded for display at less than full-size (when using one of the standard up-conversion ratios at the 30 Hz VC-1 HDTV IRD).*

Decoding: *30 Hz VC-1 HDTV IRDs shall be capable of decoding pictures with luminance resolutions as shown in table 17 and applying up sampling to allow the decoded pictures to be displayed at full-screen size.*

Table 17: Resolutions for Full-screen Display from 30 Hz VC-1 HDTV IRD

Luminance resolution (horizontal x vertical)	Coded Picture	
	Source Aspect Ratio	16:9 Monitors Horizontal up sampling
1 920 x 1 080	16:9	x 1
1 440 x 1 080	16:9	x 4/3
1 280 x 1 080	16:9	x 3/2
960 x 1 080	16:9	x 2
1 280 x 720	16:9	x 1
960 x 720	16:9	x 4/3
640 x 720	16:9	x 2

5.12.5 Colour Parameter Information

Encoding: *The chromaticity co-ordinates of the ideal display, opto-electronic transfer characteristic of the source picture and matrix coefficients used in deriving luminance and chrominance signals from the red, green and blue primaries shall be explicitly signalled in the encoded 30 Hz VC-1 HDTV Bitstream by setting the appropriate values for each of the following 3 parameters: **COLOR_PRIM**, **TRANSFER_CHAR** and **MATRIX_COEFF**.*

It is recommended that ITU-R Recommendation BT.709 [13] colorimetry is used for all 30 Hz VC-1 HDTV Bitstreams, which is signalled by setting **COLOR_PRIM** to the value 1, **TRANSFER_CHAR** to the value 1 and **MATRIX_COEFF** to the value 1.

Decoding: *30 Hz VC-1 HDTV IRDs shall support decoding bitstreams with any allowed values of **COLOR_PRIM**, **TRANSFER_CHAR** and **MATRIX_COEFF**. It is recommended that appropriate processing be included for the accurate representation of pictures using ITU-R Recommendation BT.709 [13] colorimetry.*

5.12.6 Random Access Point

Encoding: Where channel change times are important it is recommended that a Sequence Header and Entry-Point Header are encoded at least once every 500 ms. In applications where channel change time is an issue but coding efficiency is critical, it is recommended that a Sequence Header and Entry- Point Header are encoded at least once every 2 s. For those applications where channel change time is not an issue, it is recommended that a Sequence Header and Entry-Point Header are sent at least once every 5 s.

NOTE 1: Increasing the frequency of Sequence Header and Entry-Point Header will reduce channel hopping time but will reduce the efficiency of the video compression.

NOTE 2: Having a regular interval between Entry-Point Headers may improve trick mode performance, but may reduce the efficiency of the video compression.

NOTE 3: The AU_information_descriptor described in annex D provides a means of signalling information about Random Access Points that may be used by some applications, and it is recommended that this is present.

5.12.7 Backwards Compatibility

Decoding: *30 Hz VC-1 HDTV IRDs shall be capable of decoding any bitstream that a 30 Hz VC-1 SDTV IRD is required to decode and resulting in the same displayed pictures as the 30 Hz VC-1 SDTV IRD.*

5.13 MVC Stereo HDTV IRDs and Bitstreams

5.13.1 Specifications common to all MVC Stereo HDTV IRDs and Bitstreams

The specification in this clause applies to the following IRDs and Bitstreams:

- 25 Hz MVC Stereo HDTV IRD and Bitstream;
- 30 Hz MVC Stereo HDTV IRD and Bitstream.

In addition to the constraints applicable to the H.264/AVC Stereo High Profile Level 4 of ITU-T Recommendation H.264 / ISO/IEC 14496-10 [16], the constraints listed in the following clauses apply to the MVC Stereo HDTV IRDs and Bitstreams defined in the present document.

NOTE: The H.264/AVC HDTV IRD and Bitstream specification applies to MVC Stereo IRDs and Bitstreams as far as the Base view Bitstream of an MVC Stereo HDTV Bitstream shall be compliant with the H.264/AVC HDTV Bitstream specification.

5.13.1.1 Introduction

The video encoding and video decoding shall conform to ITU-T Recommendation H.264 / ISO/IEC 14496-10 [16]. Some of the parameters and fields are not used in the DVB System, or they shall take certain predetermined values. These restrictions are described below.

MVC Stereo HDTV Bitstreams and IRDs shall support some parts of the "Supplemental Enhancement Information (SEI)", the "Video usability information (VUI)", the "MVC SEI messages", and the "MVC Video Usability Information extension (MVC VUI extension)" syntax elements as specified in ITU-T Recommendation H.264 / ISO/IEC 14496-10 [16] annexes D and E and clauses H.13 and H.14.

5.13.1.2 Composition of MVC Stereo HDTV Bitstreams

Encoding: *MVC Stereo HDTV Bitstreams, as defined in this specification, shall contain a single MVC Stereo Base view bitstream and a single MVC Stereo Dependent view bitstream.*

The MVC Stereo Base view bitstream and the MVC Stereo Dependent view bitstream shall be sent in separate elementary streams and on separate PIDs.

Decoding: *MVC Stereo IRDs shall support the decoding of MVC Stereo HDTV Bitstreams, for which MVC Stereo Base view bitstream and MVC Stereo Dependent view bitstream are sent in separate elementary streams and on separate PIDs.*

5.13.1.3 MVC Sequence Parameter Set and Picture Parameter Set

The sub-section applies to MVC Base view video only.

Encoding: *In addition to the provisions relating to the MVC Stereo High Profile set forth in ITU-T Recommendation in H.264 / ISO/IEC 14496-10 [16], the following restrictions apply for the fields in the sequence parameter set:*

<i>profile_idc</i>	<i>= 100 (High Profile [16])</i>
<i>constraint_set0_flag</i>	<i>= 0</i>
<i>constraint_set1_flag</i>	<i>= 0</i>
<i>constraint_set2_flag</i>	<i>= 0</i>
<i>constraint_set3_flag</i>	<i>= 0</i>
<i>gaps_in_frame_num_value_allowed_flag</i>	<i>= 0 (gaps not allowed)</i>
<i>vui_parameters_present_flag</i>	<i>= 1</i>

Both, the pic_parameter_set_id and the seq_parameter_set_id in the MVC Base view video stream may only refer to those PPSs and SPSs present in the MVC Base view video stream. Additionally, the values of the pic_parameter_set_id and the seq_parameter_set_id parameters shall not be re-used in the MVC Dependent view video stream.

More than one PPS can be present between two MVC Stereo RAPs in the bitstream.

Multiple PPSs may be present in an MVC Stereo RAP access unit. Additionally, the following constraints apply:

- there shall be at least one and at most 30 PPSs in the first dependent unit in a coded video sequence.
- there shall be one or zero PPSs in each dependent unit, except for the first dependent unit in a coded video sequence.

5.13.1.4 pic_width_in_mbs_minus1 and pic_height_in_map_units_minus1

Encoding: *The values of pic_width_in_mbs_minus1 and pic_height_in_map_units_minus1 shall not change in an MVC Stereo HDTV Bitstream and they shall take the same value in the Base and Dependent view bitstreams.*

If the number of samples per row of the luminance component of the source picture for any MVC view component is not an integer multiple of 16 and additional samples are padded to make the number of samples per row of the luminance component an integer multiple of 16, it is recommended that these samples are padded at the right side of the picture.

If the number of samples per column of the luminance component of the source picture for any MVC view component is not an integer multiple of 16 and additional samples are padded to make the number of samples per column of the luminance component an integer multiple of 16, it is recommended that these samples are padded at the bottom of the picture.

5.13.1.5 Subset Sequence Parameter Set

Encoding: *In addition to the provisions set forth in ITU-T Recommendation H.264 / ISO/IEC 14496-10 [16], the following restrictions shall apply for the fields in the subset sequence parameter sets (nal_unit_type is equal to 15):*

mvc_vui_parameters_present_flag = 1

In embedded sequence_parameter_set_data():

profile_idc = 128 (Stereo High Profile [16])

In embedded seq_parameter_set_mvc_extension():

num_level_values_signalled_minus1 = 0

In embedded mvc_vui_parameters_extension():

vui_mvc_num_ops_minus1 = 0

vui_mvc_low_delay_hrd_flag = 0 (if present)

vui_mvc_pic_struct_present_flag = 0/1 (same value as 'pic_struct_present_flag' SPS of Base view)

The SPS encoded in the Subset SPS shall take the same values as the SPS of the Base view, with the exception of seq_parameter_set_id, and profile_idc. Exactly one Subset SPS shall be provided in the first Dependent view component of every coded video sequence (in decoding order). This Subset SPS is referenced by all PPSs in a coded video sequence and no other Subset SPS shall appear in a coded video sequence.

5.13.1.6 Video Usability Information

In addition to the requirements specified in clause 5.5.3, the VUI parameters, vui_parameters(), which are encoded in SPS in Subset SPS for MVC Dependent view video stream, shall have the same values as the VUI parameters in SPS of the corresponding MVC Base view video stream, except for the following parameter, which if present, may take different values:

- hrd_parameters()
- max_dec_frame_buffering
- num_reorder_frames
- max_bytes_per_pic_denom

5.13.1.6.1 MVC VUI parameters

The MVC VUI parameters extension (mvc_vui_parameters_extension()), shall be present in the Dependent view bitstream and encoded in the Subset SPS, and they shall have the same values as VUI parameters in SPS for corresponding view bitstream except for the following parameters, which, if present, may take different values:

- hrd_parameters()

5.13.1.6.2 Aspect Ratio

Encoding: *The source aspect ratio in MVC Stereo HDTV Bitstreams shall be 16:9. The aspect ratio shall be the same for Base view and Dependent view video.*

*The source aspect ratio information shall be derived from the **aspect_ratio_idc** value in the Video Usability Information (see values of **aspect_ratio_idc** in ITU-T Recommendation H.264 / ISO/IEC 14496-10 [16], table E-1).*

The frame cropping information in the Sequence Parameter Set may be used when appropriate.

Decoding: *MVC Stereo HDTV IRDs shall support decoding and displaying MVC Stereo HDTV Bitstreams with the values of **aspect_ratio_idc** as specified in table 18.*

*The source aspect ratio information shall be derived from the **pic_height_in_map_units_minus1** and the **pic_width_in_mbs_minus1** and the frame cropping information coded in the Sequence Parameter Set as well as the sample aspect ratio encoded with the **aspect_ratio_idc** value in the Video Usability Information (see values of **aspect_ratio_idc** in ITU-T Recommendation H.264 / ISO/IEC 14496-10 [16], table E-1).*

MVC Stereo HDTV IRDs shall support frame cropping for the resolutions specified in Table 18.

5.13.1.6.3 Colour Parameter Information

Encoding: *The chromaticity coordinates of the ideal display, opto-electronic transfer characteristic of the source picture and matrix coefficients used in deriving luminance and chrominance signals from the red, green and blue primaries shall be explicitly signalled in each of the encoded MVC Stereo Base view and Dependent view bitstreams by setting the appropriate values for each of the following 3 parameters in the VUI: **colour_primaries**, **transfer_characteristics**, and **matrix_coefficients**.*

These parameters shall take the same values for Base and Dependent view components.

It is recommended that ITU-R Recommendation BT.709 [13] colorimetry is used for all MVC Stereo HDTV bitstreams, which is signalled by setting **colour_primaries** to the value 1, **transfer_characteristics** to the value 1 and **matrix_coefficients** to the value 1.

Decoding: *MVC Stereo HDTV IRDs shall be capable of decoding MVC Bitstreams with any allowed values of **colour_primaries**, **transfer_characteristics** and **matrix_coefficients**. It is recommended that appropriate processing be included for the accurate representation of pictures using ITU-R Recommendation BT.709 [13] colorimetry.*

5.13.1.6.4 Luminance Resolution

Encoding: *MVC Stereo HDTV Bitstreams shall represent video with luminance resolutions as shown in table 18. Non full-screen pictures may be encoded for display at less than full-size (when using one of the standard up-conversion ratios at the MVC Stereo HDTV IRD).*

Decoding: *MVC Stereo HDTV IRDs shall be capable of decoding pictures with luminance resolutions as shown in table 18 and applying up sampling to allow the decoded pictures to be displayed at full-screen size.*

Table 18: Resolutions for Full-screen Display from MVC Stereo HDTV IRD

Coded Picture			
Luminance resolution (horizontal x vertical)	Source Aspect Ratio	aspect_ratio_idc	16:9 Monitors Horizontal up sampling
1 920 x 1 080	16:9	1	x 1
1 440 x 1 080	16:9	14	x 4/3
1 280 x 1 080	16:9	15	x 3/2
960 x 1 080	16:9	16	x 2
1 280 x 720	16:9	1	x 1
960 x 720	16:9	14	x 4/3
640 x 720	16:9	16	x 2

5.13.1.7 HRD Conformance

The MVC Stereo Dependent view video bitstream shall conform to Type 2 (NAL level) HRD conformance, with output timing conformance.

The HRD parameters (hrd_parameters()), if present in VUI parameters (vui_parameters()), in SPS encoded in Subset SPS for MVC Stereo Dependent view video stream shall fulfill HRD conformance for the MVC Stereo Dependent view component.

The HRD parameters (*hrd_parameters()*), if present in MVC VUI parameters encoded in Subset SPS, (*mvc_vui_parameters_extension()*) shall conform to HRD conformance for both MVC Stereo Base view component and MVC Stereo Dependent view component as MVC Stereo access unit. In other words, the timing for decoding and presentation shall be the same for Base and Dependent view components, even though the specific values for the *hrd_parameters()* might be different.

NOTE: as pointed out below, HRD parameters in *vui_parameters()*, when present, might be different from those HRD parameters in *mvc_vui_parameters_extensions()*

Furthermore, for each of these view components independently, and within the accuracy of their respective clocks, the Decoding Time Stamp and Presentation Time Stamp shall indicate the same instant in time as the nominal CPB removal time and the DPB output time in the HRD respectively when picture timing SEI information is transmitted (per clause 2.4.3.7 ISO/IEC 13818-1 [1]). This ensures consistency between the STD model of ISO/IEC 13818-1 [1] and the HRD model of ITU-T Recommendation H.264 / ISO/IEC 14496 10 [16].

5.13.1.8 Supplemental Enhancement Information

In addition to the requirements specified in clause 5.5.4, the IRD shall support the use of the following message type, which shall be sent in MVC Stereo Base view component:

- Multiview View Position SEI message, which is used to indicate which of base or dependent view corresponds to the left or right eye, as well as to indicate that the MVC Base view component containing the SEI message is part of an MVC Stereo HDTV bitstream and as such is associated to an MVC Dependent view component. Clause 5.13.1.8.3 gives further details on the Multiview View Position SEI message.

Furthermore, the IRD shall support the use of the following message type, which shall only be sent in MVC Stereo Dependent access units:

- Scalable Nesting SEI Message.

Additionally, the following applies:

- The IRD may support the use of the **multi_region_disparity** message, as specified in Annex B.11, which, when present in the MVC Stereo HDTV Bitstream, shall be included in a "User data registered by ITU-T Recommendation T.35 [19] SEI message" contained in an MVC scalable nesting SEI message, and which shall be sent for every MVC Stereo Dependent view component.
- When Buffering Period SEI and/or Picture Timing SEI are encoded in the MVC Stereo Base view bitstream, same SEIs shall be encoded in the MVC scalable nesting SEI message of the MVC Stereo Dependent view bitstream with the same values, except for *seq_parameter_set_id*, which must be different.
- If decoded reference picture marking syntax is repeated using a Decoded reference picture marking repetition SEI message in a MVC Stereo Base view component, then the same syntax shall be repeated in the Corresponding view component of the MVC Stereo Dependent view bitstream by using a Decoded reference picture marking repetition SEI.
- All SEI messages present for the Dependent view shall be placed inside the MVC scalable nesting SEI message.

5.13.1.8.1 Prohibited SEI messages

The following SEI messages shall not be present in the MVC Base view bitstream:

- Non-required view component SEI message (since all (two) views are used).
- View dependency change SEI message (because there is just one dependent view).
- MVC scalable nesting SEI message (because operating points are not used in MVC Stereo High Profile).
- "User data registered by ITU-T Recommendation T.35 [19] SEI message" containing the message *multi_region_disparity()*.

The following SEI messages shall not be present in the MVC Dependent view bitstream:

- The MVC Dependent view bitstream shall not contain any SEI message outside the MVC scalable nesting SEI message.
- Following SEI messages shall not be present in the MVC scalable nesting SEI message:
 - Stereo video information SEI message.
 - Pan-scan rectangle SEI message.
 - Non-required view component SEI message.
 - View dependency change SEI message.
 - Multiview View Position SEI message (because it is already transmitted in the MVC Base view bitstream).

5.13.1.8.2 Order of SEI Messages

SEI messages in the dependent unit shall be stored in the following order:

- MVC scalable nesting SEI message containing a Buffering period SEI message (if present)
- MVC scalable nesting SEI message containing a "User data registered by ITU-T Recommendation T.35 [19] SEI message", which itself contains the message `multi_region_disparity()` as defined in Annex B.11. Multi region disparity may be sent in the Dependent view bitstream for each access unit.
- Other SEI messages in the MVC scalable nesting SEI message (if present)

5.13.1.8.3 Multiview View Position SEI message

Encoding: *The Multiview View Position SEI message shall be present in every access unit of an MVC Stereo Base view bitstream.*

Its presence signals that the H.264/AVC access unit containing the SEI message is an MVC Stereo Base view component associated to an MVC Stereo Dependent view component.

The Multiview View Position SEI message associates the base and dependent view to the left and right eye.

*The value of the syntax element **num_views_minus1** shall be set to '1'.*

Decoding: *MVC Stereo IRDs shall support the Multiview View Position SEI message.*

*MVC Stereo IRDs shall ignore Multiview View Position SEI messages with a value of **num_views_minus1** not equal to '1'.*

5.13.1.9 Random Access Point

The definition for MVC Stereo RAP in clause 3 shall apply.

Encoding: The time interval between MVC Stereo RAPs may vary between programs and also within a program. The broadcast requirements should set the time interval between MVC Stereo RAPs as specified in 5.13.1.9.1.

NOTE: The `AU_information_descriptor` described in Annex D provides a means of signalling information about Random Access Points that may be used by some applications, and it is recommended that this is present. *The `AU_information_descriptor` may be present in the Base view bitstream and it shall not be present in the Dependent view bitstream.*

All pictures with PTS greater than or equal to PTS(rap) shall be fully reconstructible and displayable, where PTS(rap) represents the Presentation Time Stamp of the picture of the MVC Stereo RAP. This means that decoders receiving the RAP shall not need to utilise data transmitted prior to the RAP to decode pictures displayed after the RAP, at either Base or Dependent view. See clause I.1 for details.

To improve applications such as channel change, it is recommended that the Presentation Time Stamp of the picture of MVC Stereo RAP be less than or equal to [DTS(rap) + 0,5 seconds] where DTS(rap) represents the Decoding Time Stamp of the picture of MVC Stereo RAP.

Packetization of random access points shall comply with the following additional rule:

A transport packet containing the PES header of an MVC Stereo RAP or an MVC Stereo random access view component shall have an adaptation field. The **payload_unit_start_indicator** bit shall be set to "1" in the transport packet header and the **adaptation_field_control** bits shall be set to "11" (as per ITU-T Recommendation H.222.0 / ISO/IEC 13818-1 [1]). In addition, the **random_access_indicator** bit in the adaptation header shall be set to "1". The **elementary_stream_priority_indicator** bit shall also be set to "1" in the same adaptation header if this transport packet contains the slice start code of the MVC Stereo Base view component (see clauses 4.1.5.1 and 4.1.5.2).

Decoding: MVC Stereo IRDs shall be able to start decoding and displaying an MVC Stereo Bitstream at an MVC Stereo RAP.

5.13.1.9.1 Time Interval Between RAPs

Encoding: The encoder shall place MVC Stereo RAPs in the MVC Stereo bitstream at least once every 5 s. It is recommended that MVC Stereo RAPs occur in the MVC Stereo bitstream on average at least every 2 s. Where rapid channel change times are important or for applications such as PVR it may be appropriate for MVC Stereo RAPs to occur more frequently, such as every 500 ms. The time interval between successive RAPs shall be measured as the difference between their respective DTS values.

NOTE 1: Decreasing the time interval between MVC Stereo RAPs may reduce channel hopping time and improve trick modes, but may reduce the efficiency of the video compression.

NOTE 2: Having a regular interval between MVC Stereo RAPs may improve trick mode performance, but may reduce the efficiency of the video compression.

NOTE 3: 3D trick-modes should be used with care, as they might cause the rendered video to deviate from the recommended production guidelines (e.g. fast-forwarding of 3D video).

5.13.1.10 Additional constraints

5.13.1.10.1 Constraints Common to Base and Dependent Views

In addition to Base and Dependent view adopting the same values (except if noted otherwise) for the parameters as described in previous clauses, the following parameter values shall not change for the duration of the presentation:

- *level_idc*, which shall be equal to '40'.
- *frame-rate*, which shall be derived from $time_scale / num_units_in_tick / 2$.
- Coded Picture Buffer size (CPB), $CpbSize[cpb_cnt_minus1]$, derived from cpb_size_scale and $cpb_size_value_minus1$, when $hrd_parameters()$ are present).
- Maximum input bit-rate to the CPB. The maximum input bitrate is $BitRate[cpb_cnt_minus1]$, derived from bit_rate_scale and $bit_rate_value_minus1$, when $hrd_parameters()$ is present.

NOTE: Base and Dependent views may have different values for $hrd_parameters()$, see clause.5.13.1.8.

- *frame_mbs_only_flag*

- `entropy_coding_mode_flag`. *The `entropy_coding_mode_flag` shall have the same value for base and dependent view and shall not change in the bitstream*
- `view_id` in the `nal_unit_header_mvc_extension()` in the Dependent view bitstream, which shall take a value different from zero. *View_id shall be set to zero, '0', for the Base view video, see 5.13.1.10.3*

5.13.1.10.2 MVC Stereo Base view constraints

5.13.1.10.3 Prohibited NAL units

Following NAL units shall not be present in the MVC Stereo Base view component video for reasons of backwards-compatibility:

- Prefix NAL unit, `nal_unit_type` = 14: this NAL unit is specified in ITU-T Recommendation H.264 / ISO/IEC 14496-10 [16] to convey the `nal_unit_header_mvc_extension()` for MVC Base view video. However, the use of this NAL unit in this specification is disallowed for DVB services. *Therefore, the following constant values shall be assumed for the parameters in the `nal_unit_header_mvc_extension()`:*
 - *`non_idr_flag` shall be set according to `nal_unit_type` of corresponding Base view component. E.g. if `nal_unit_type` of Base view component is set to '5' (IDR picture), `non_idr_flag` shall be set to '0', otherwise `non_idr_flag` shall be set to '1'.*
 - *`priority_id` shall be set to '0' (highest priority)*
 - *`view_id` shall be set to '0' (base view)*
 - *`temporal_id` in the Base and Dependent view components shall be set to the same value.*
 - *`anchor_pic_flag` in the Base and Dependent view components shall be set to the same value.*
 - *`inter_view_flag` shall be set to '1'.*
- Coded slice extension NAL unit, `nal_unit_type` = 20.
- Subset Sequence Parameter set NAL unit, `nal_unit_type` = 15.

5.13.1.10.4 MVC Stereo Dependent view constraints

In the Coded slice extension NAL unit, `nal_unit_type` = 20, the `svc_extension_flag` shall be set to '0', meaning dependent video bitstream complies with Annex H of ITU-T Recommendation H.264 / ISO/IEC 14496-10 [16].

Furthermore, the following clauses apply.

5.13.1.10.4.1 Prohibited NAL units

The following NAL units shall not be present in the MVC Stereo Dependent view component video for reasons of backwards-compatibility:

- Access unit delimiter NAL unit, `nal_unit_type` = 9.
- Sequence parameter set extension NAL unit, `nal_unit_type` = 13.
- Coded slice of the auxiliary coded picture without partitioning NAL unit, `nal_unit_type` = 19.

5.13.1.11 Access Unit Structure

For MVC Base view video, the AU structure is that of the H.264/AVC video, as per the present document.

For MVC Dependent view video, figure 1 shows an overview of the Dependent Unit structure for the first and subsequent Units in a coded video sequence.

First Dependent AU in coded video sequence

View Component of Dependent View

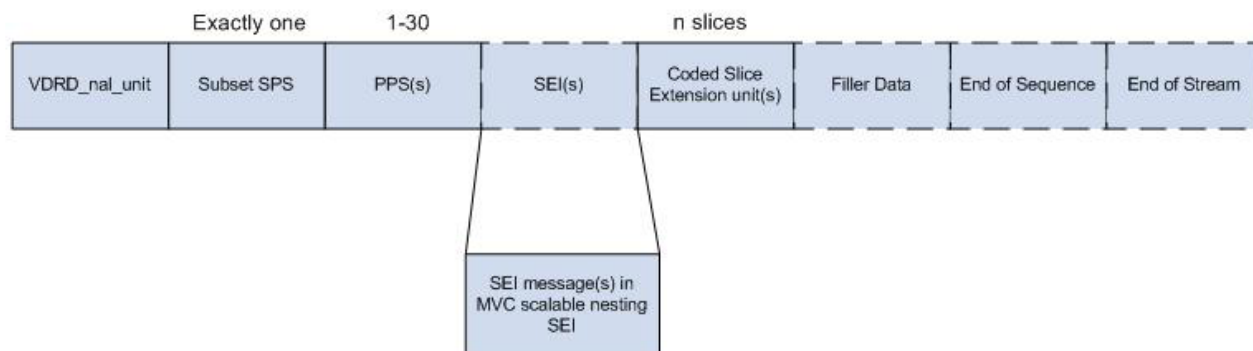

Subsequent Dependent AU in coded video sequence

View Component of Dependent View

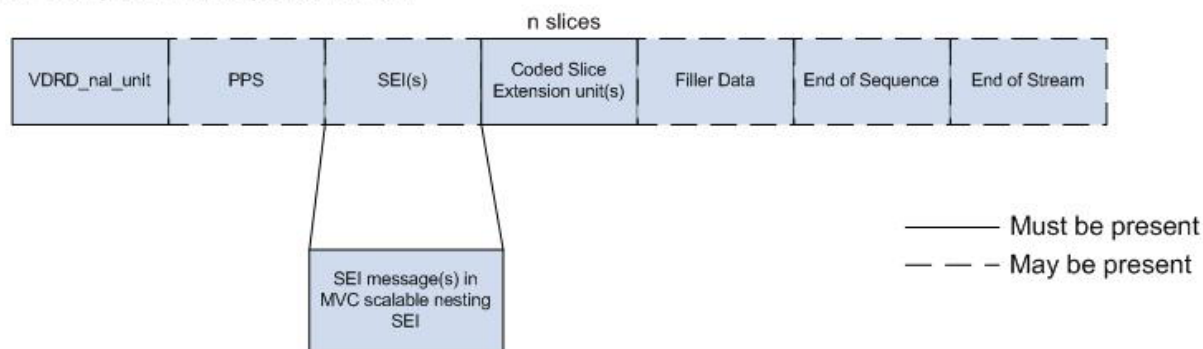

Figure 1: AU Structure for Dependent video

The first Dependent Unit in a coded video sequence shall be composed of following NAL units, which shall be present in this order:

- View and dependency representation delimiter NAL unit, VDRD_nal_unit (nal_unit_type = 24).
- Exactly one Subset SPS NAL unit.
- One or more PPS NAL units.
- One or more SEI NAL units (if present).
- One or more coded slice extension NAL unit(s) (nal_unit_type = 20) as required by number of slices in the anchor picture.
- A Filler data NAL unit (if required) (see note 1).
- An End of sequence NAL unit (if applicable) (see note 2).
- An End of stream NAL unit (if applicable) (see note 3).

Any subsequent Dependent Units in a coded video sequence of MVC Dependent view video shall have following NAL units, in this order:

- Exactly one View and dependency representation delimiter NAL unit (nal_unit_type = 24)
- One or zero PPS NAL units.
- One or more SEI NAL units, if present.

- Following NAL unit is repeated by number of slices:
 - Coded slice extension NAL unit(s), i.e. coded slice of an anchor picture or a non-anchor picture.
- A Filler data NAL unit (see note 1) (if required).
- An End of sequence NAL unit (see note 3) (if applicable).
- An End of stream NAL unit (see note 3) (if applicable).

NOTE 1: Filler data NAL unit can be placed in any position unless it precedes the first slice NAL unit.

NOTE 2: *When an End of sequence NAL unit exists in MVC Stereo Base view component, an End of sequence NAL unit shall exist in MVC Stereo Dependent view component in a same access unit.*

NOTE 3: *When an End of stream NAL unit exists in MVC Stereo Base view component, an End of stream NAL unit shall exist in MVC Stereo Dependent view component in a same access unit.*

5.13.2 25 Hz MVC Stereo HDTV IRD and Bitstream

This clause specifies the 25 Hz MVC Stereo HDTV IRD and Bitstream. *All specifications in clauses 5.5 and 5.13.1 shall apply.*

5.13.2.1 Profile and level

Encoding: *25 Hz MVC Stereo HDTV Bitstreams shall comply with the Stereo High Profile Level 4 restrictions, as specified in ITU-T Recommendation H.264 / ISO/IEC 14496-10 [16].*

*The value of **level_idc** shall be equal to 40. Base and Dependent view bitstreams shall have the same level_idc value.*

Decoding: *25 Hz MVC Stereo HDTV IRDs shall support the decoding of Stereo High Profile Level 4 bitstreams. This requirement includes support for Stereo High Profile and levels 3 to 4. Support for profiles and levels other than High Profile Level 3 to 4 is optional. If the 25 Hz MVC Stereo HDTV IRD encounters an extension which it cannot decode, it shall discard the following data until the next start code prefix (to allow backward compatible extensions to be added in the future).*

5.13.2.2 Frame rate

Encoding: *The frame rate shall be 25 Hz or 50 Hz. This shall be indicated in the VUI by setting **time_scale** and **num_units_in_tick** according to table 12. Time_scale and num_units_in_tick define the picture rate of the video. The source video format for 50 Hz frame rate material shall be progressive. The source video format for 25 Hz frame rate material shall be interlaced or progressive.*

Decoding: *25 Hz MVC Stereo HDTV IRDs shall support decoding and displaying video with a frame rate of 25 Hz interlaced or progressive, or 50 Hz progressive within the constraints of High Profile at Level 4.*

Support of other frame rates is optional.

5.13.2.3 Backwards Compatibility

Decoding: *25 Hz MVC Stereo HDTV IRDs shall be capable of decoding any bitstream that a 25 Hz H.264/AVC SDTV IRD and a H.264/AVC HDTV IRD are required to decode and resulting in the same displayed pictures as the 25 Hz H.264/AVC SDTV IRD and 25 Hz H.264/AVC HDTV IRD, as described in clauses 5.6.2 and 5.7.2.*

5.13.3 30 Hz MVC Stereo HDTV IRD and Bitstream

This clause specifies the 30 Hz MVC Stereo HDTV IRD and Bitstream. *All specifications in clauses 5.5 and 5.13.1 shall apply.* The specification in the remainder of this clause only applies to the 30 Hz MVC Stereo HDTV IRD and Bitstream.

5.13.3.1 Profile and level

Encoding: *30 Hz MVC Stereo HDTV sub-bitstreams shall comply with the Stereo High Profile Level 4 restrictions, as specified in ITU-T Recommendation H.264 / ISO/IEC 14496-10 [16].*

The value of `level_idc` shall be equal to 40.

Decoding: *30 Hz MVC Stereo HDTV IRDs shall support the decoding of Stereo High Profile Level 4 bitstreams. This requirement includes support for Stereo High Profile and levels 3 to 4. Support for profiles and levels other than Stereo High Profile, Level 3 to 4 is optional. If the 30 Hz MVC Stereo HDTV IRD encounters an extension which it cannot decode, it shall discard the following data until the next start code prefix (to allow backward compatible extensions to be added in the future).*

5.13.3.2 Frame rate

Encoding: *The frame rate shall be 24 000/1 001, 24, 30 000/1 001, 30, 60 000/1 001 or 60 Hz. This shall be indicated in the VUI by setting `time_scale` and `num_units_in_tick` according to table 13. `Time_scale` and `num_units_in_tick` define the picture rate of the video. The source video format for 24 000/1 001, 24, 60 000/1 001 and 60 Hz frame rate material shall be progressive. The source video format for 30 000/1 001 and 30 Hz frame rate material shall be interlaced or progressive.*

Decoding: *30 Hz MVC Stereo HDTV IRDs shall support decoding and displaying video with a frame rate of 30 000/1 001, 30 Hz interlaced or progressive, or 24 000/1 001, 24, 60 000/1 001 or 60 Hz progressive within the constraints of High Profile at Level 4.*

Support of other frame rates is optional.

5.13.3.3 Backwards Compatibility

Decoding: *30 Hz MVC Stereo HDTV IRDs shall be capable of decoding any bitstream that a 30 Hz H.264/AVC SDTV IRD and a 30 Hz H.264/AVC SDTV IRD are required to decode and resulting in the same displayed pictures as the 30 Hz H.264/AVC SDTV IRD and 30 Hz H.264/AVC SDTV IRD, as described in clauses 5.7.2 and 5.7.3.*

6 Audio

This clause describes the guidelines for encoding MPEG-1 or MPEG-2 Layer II backward compatible audio, or AC-3 audio, or Enhanced AC-3 audio, or DTS audio, or DTS-HD audio, or MPEG-4 AAC audio, or MPEG-4 HE AAC audio, or MPEG-4 HE AAC v2 audio, or combinations of MPEG Surround audio with MPEG-1 Layer II, MPEG-4 AAC audio, or MPEG-4 HE AAC audio, or MPEG-4 HE AAC v2 audio in DVB broadcast bitstreams, and for decoding this bitstream in the IRD.

The following clauses do not imply that either MPEG-1 audio, or MPEG-2 Layer II backward compatible audio, or AC-3 audio, or Enhanced AC-3 audio, or DTS audio, or DTS-HD audio, or MPEG-4 AAC audio, or MPEG-4 HE AAC audio, or MPEG-4 HE AAC v2 audio, or combinations of MPEG Surround with MPEG-1 Layer II, MPEG-4 AAC audio, or MPEG-4 HE AAC audio, or MPEG-4 HE AAC v2 audio are mandatory. *The codecs that a given IRD supports will define which of the following clauses the IRD shall comply with.*

The recommended level for reference tones for transmission is 18 dB below clipping level, in accordance with EBU Recommendation R.68 [11].

6.1 MPEG-1 and MPEG-2 backward compatible audio

MPEG-1 and MPEG-2 backward compatible audio encoding shall conform to either ISO/IEC 11172-3 [9] or ISO/IEC 13818-3 [3]. Some of the parameters and fields in ISO/IEC 11172-3 [9] and ISO/IEC 13818-3 [3] are not used in the DVB System and these restrictions are described below.

The design of an IRD compatible with MPEG-1 and/or MPEG-2 backward compatible audio should be made under the assumption that any legal structure as permitted by ISO/IEC 11172-3 [9] or ISO/IEC 13818-3 [3] may occur in the broadcast stream even if presently reserved or unused. *To allow full compliance to ISO/IEC 11172-3 [9] and ISO/IEC 13818-3 [3] and upward compatibility with future enhanced versions, a DVB IRD shall be able to skip over data structures which are currently "reserved", or which correspond to functions not implemented by the IRD. For example, an IRD which is not designed to make use of the ancillary data field shall skip over that portion of the bitstream.*

This clause is based on ISO/IEC 11172-3 [9] (MPEG-1 audio) and ISO/IEC 13818-3 [3] (MPEG-2 backward compatible audio).

Optionally, also the combination of MPEG-1 Layer II with MPEG Surround is supported. The encoding and decoding of MPEG Surround complies with ISO/IEC 23003-1 [29] and [31]. MPEG Surround creates a (mono or stereo) downmix from the multi-channel audio input signal. This downmix is encoded using a core audio codec, in this case MPEG-1 Layer II. In addition, MPEG Surround generates a spatial image parameter description of the multi channel audio that is added as an ancillary data stream to the core audio codec. Legacy mono or stereo decoders ignore the ancillary data and play back a stereo respectively mono audio signal. MPEG Surround capable decoders will first decode the mono or stereo core codec audio signal and then use the spatial image parameters extracted from the ancillary data stream to generate a high quality multi channel audio signal.

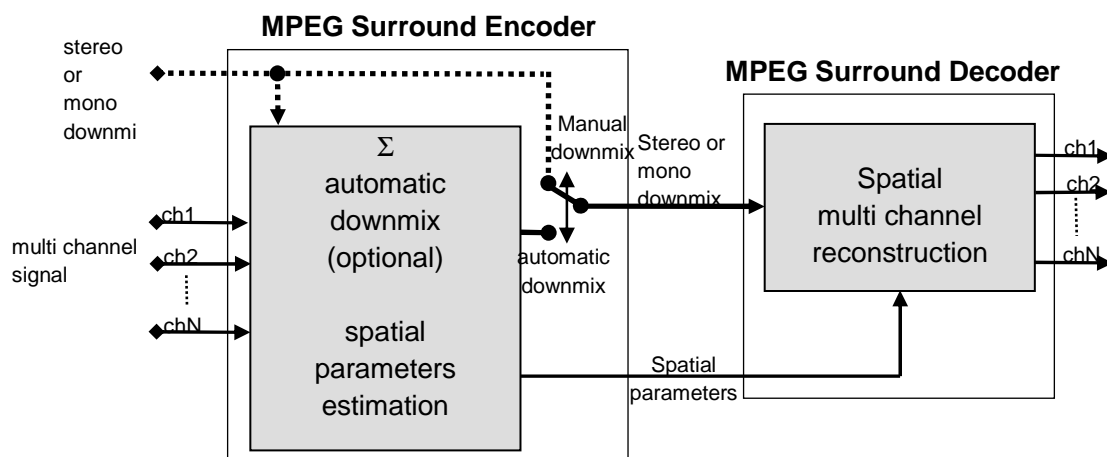

Figure 1a: Principle of MPEG Surround, the downmix is coded using MPEG-1 Layer II

This clause is based on ISO/IEC 11172-3 [9] and ISO/IEC 13818-1 [28] and [31]).

6.1.1 Audio mode

Encoding: *MPEG-1 and MPEG-2 backward compatible audio shall be encoded in one of the following modes:*

- ISO/IEC 11172-3 [9] single channel;
- ISO/IEC 11172-3 [9] joint stereo;
- ISO/IEC 11172-3 [9] stereo;
- ISO/IEC 13818-3 [3] multi-channel audio, backwards compatible to ISO/IEC 11172-3 [9] (dematrix procedure = 0, 1 or 2).

In addition, audio may be encoded in ISO/IEC 11172-3 [9] dual channel mode, as specified by TS 102 005 [i.3], in a transmission intended both as a contribution feed and for Direct-To-Home (DTH) reception. However, this is not recommended. Care needs to be taken to ensure that the optional dual channel decoding mode is supported in the DTH IRD. Furthermore, there may be problems due to the left/right channel selection being performed by different equipment from the decoding unit (e.g. decoding may be by a set-top-box but left/right channel selection and audio balance may be performed by the TV set).

Decoding: *IRDs compatible with MPEG-1 and/or MPEG-2 backward compatible audio shall be capable of decoding the following audio modes:*

- ISO/IEC 11172-3 [9] single channel;
- ISO/IEC 11172-3 [9] joint stereo;
- ISO/IEC 11172-3 [9] stereo.

IRDs compatible with MPEG-1 and/or MPEG-2 backward compatible audio shall be capable of decoding at least the ISO/IEC 11172-3 [9] compatible basic stereo information from an ISO/IEC 13818-3 [3] multi-channel audio bitstream. Full decoding of an ISO/IEC 13818-3 [3] multi-channel audio bitstream is optional.

Support for decoding of ISO/IEC 11172-3 [9] dual channel is optional.

6.1.2 Layer

Encoding: *An ISO/IEC 11172-3 [9] encoded bitstream shall use either Layer I or Layer II coding (**layer** = "11" or "10" respectively). Use of Layer II is recommended.*

*An ISO/IEC 13818-3 [3] multi-channel encoded bitstream shall use Layer II coding (**layer** = "10").*

Decoding: *IRDs shall be capable of decoding Layer I and Layer II. In case the IRD supports MPEG Surround decoding, it shall support the combination of MPEG-1 Layer II with MPEG Surround. The IRD shall interpret these formats in accordance with MPEG-1 and MPEG Surround audio syntax.*

6.1.3 Bitrate

Encoding: *The value of **bitrate_index** in the encoded bitstream shall be one of the 14 values from "0001" to "1110"(inclusive).*

For Layer I, these correspond to bitrates of: 32 kbits/s, 64 kbits/s, 96 kbits/s, 128 kbits/s, 160 kbits/s, 192 kbits/s, 224 kbits/s, 256 kbits/s, 288 kbits/s, 320 kbits/s, 352 kbits/s, 384 kbits/s, 416 kbits/s or 448 kbits/s.

For Layer II, these correspond to bitrates of: 32 kbits/s, 48 kbits/s, 56 kbits/s, 64 kbits/s, 80 kbits/s, 96 kbits/s, 112 kbits/s, 128 kbits/s, 160 kbits/s, 192 kbits/s, 224 kbits/s, 256 kbits/s, 320 kbits/s and 384 kbits/s.

For ISO/IEC 13818-3 [3] encoded bitstreams with total bitrates greater than 384 kbit/s, an extension bitstream shall be used. The bitrate of that extension may be in the range of 0 to 682 kbit/s.

Decoding: *IRDs shall be capable of decoding bitstreams with a value of **bitrate_index** from "0001" to "1110"(inclusive). Support for the free format bitrate (**bitrate_index** = "0000") is optional.*

6.1.4 Sampling frequency

Encoding: *The audio sampling rate of primary sound services shall be 32 kHz, 44,1 kHz or 48 kHz. Sampling rates of 16 kHz, 22,05 kHz, 24 kHz, 32 kHz, 44,1 kHz or 48 kHz may be used for secondary sound services.*

Decoding: *The IRD shall be capable of decoding audio with sampling rates of 32 kHz, 44,1 kHz and 48 kHz. Support for sampling rates of 16 kHz, 22,05 kHz and 24 kHz is optional.*

6.1.5 Emphasis

Encoding: *The encoded bitstream shall have no emphasis (**emphasis** = "00").*

Decoding: *The IRD shall be capable of decoding audio with no emphasis. Support for 50/15 microseconds de-emphasis and ITU-T Recommendation J.17 [10] de-emphasis (**emphasis** = "01" or "11") is optional.*

6.1.6 Cyclic redundancy code

Encoding: *The parity check word (**crc_check**) shall be included in the encoded bitstream.*

Decoding: *It is recommended that the IRD use **crc_check** to detect errors and subsequently invoke suitable concealment or muting mechanisms.*

6.1.7 Prediction

Encoding: *ISO/IEC 13818-3 [3] multichannel encoded bitstreams shall not use **mc_prediction** (**mc_prediction_on** equals "0").*

Decoding: *The IRD shall be capable of decoding ISO/IEC 13818-3 [3] multichannel encoded bitstreams which do not use **mc_prediction**.*

6.1.8 Multilingual

Encoding: *ISO/IEC 13818-3 [3] multichannel encoded bitstreams shall not contain multilingual channels (**no_of_multilingual_channels** equals "0").*

Decoding: *The IRD shall be capable of decoding ISO/IEC 13818-3 [3] multichannel encoded bitstreams which do not contain multilingual channels.*

6.1.9 Extension Stream

Encoding: *When an ISO/IEC 13818-3 [3] encoded bitstream uses an extension stream, it is recommended that a continuous stream of extension frames is maintained for the duration of a programme, even if a total bitrate of less than 384 kbits/s would be sufficient to encode individual frames. This prevents undesired resets of the audio decoder.*

6.1.10 Ancillary Data

Encoding: *ISO/IEC 13818-3 [3] stereo or multichannel encoded bitstreams may contain ancillary data as described in annex C. It is recommended to include the data in the bitstream.*

- *In order to support the contribution of DAB signals, the ancillary data field may embed the DAB ancillary data field [18].*
- *In order to support the transmission of RDS data to DVB receivers and analogue UKW/FM transmitters, the ancillary data field may embed RDS data via the UECP protocol.*
- *If data fields according to DVD-Video extended ancillary data (as described in annex C) or ancillary data according to the DAB specification [18] are used, they have, for backward compatibility reasons, to be the first data field at the end of the audio frame. This means that a common usage of DVD-Video and DAB data is excluded.*

Decoding: *The IRD may interpret the ancillary data field in an ISO/IEC 13818-3 [3] stereo or multichannel bitstream as described in annex C and it is recommended that the contribution IRD make use of this data.*

6.1.11 MPEG Surround configurations, profiles and levels

The baseline MPEG Surround profile is defined in ISO/IEC 23003-1 [29] and ISO/IEC 23003-1:2007/Cor:2008, TECHNICAL CORRIGENDUM 1 [30]. *For the combination of MPEG Surround with MPEG-1 Layer II, the baseline MPEG Surround profile shall be used together with the restrictions defined in clauses 6.1.1 to 6.1.10.*

The MPEG Surround bitstream payload shall comply with level 3 or 4 of the Baseline MPEG Surround profile.

Encoding: *In case of the combination of MPEG-1 Layer II with MPEG Surround, the MPEG Surround bitstream shall be embedded into the ancillary data of the MPEG-1 Layer II bitstream using the AncDataElement() bitstream element as defined in ISO/IEC 23003-1 [29]. For MPEG-1 Layer II, the spatial frame length, indicated by the bsFrameLength parameter, shall correspond to the MPEG-1 Layer II frame length. Hence, the bsFrameLength shall be one of the following values: {17, 35}, resulting in effective MPEG Surround frame lengths of 1 152 and 2 304 time domain samples respectively.*

Decoding: *The IRD, if compatible with MPEG-1 Layer II audio and capable of decoding MPEG Surround and capable of providing 7.1 channels or more of output, shall be capable of providing decoder output according to MPEG Surround Baseline profile level 4.*

The IRD, if compatible with MPEG-1 Layer II audio and capable of decoding MPEG Surround and capable of providing more than two and up to 5.1 channels of output shall be capable of providing decoder output according to MPEG Surround Baseline profile level 3.

The IRD, if compatible with MPEG-1 Layer II audio and capable of decoding MPEG Surround and capable of providing 2.0 channels of output shall be capable of providing decoder output according to MPEG Surround Baseline profile level 1.

6.2 AC-3 and Enhanced AC-3 audio

The coding and decoding of AC-3 and Enhanced AC-3 elementary streams is based upon TS 102 366 [12].

IRDs compatible with AC-3 shall decode all bitrates and sample rates listed in TS 102 366 [12] (not including annex E).

IRDs compatible with Enhanced AC-3 shall additionally decode Enhanced AC-3 streams with data rates from 32 kbps to 3 024 kbps and support all sample rates listed in TS 102 366 [12], annex E.

Enhanced AC-3 bit streams are similar in nature to standard AC-3 bit streams, but are not backwards compatible (i.e. they are not decodable by standard AC-3 decoders). Some constraints are placed on the PES layer for the case of multiple audio streams intended to be reproduced in exact sample synchronism as described in clause 6.2.1.

6.2.1 AC-3 and Enhanced AC-3 PES constraints

6.2.1.1 Encoding

In some applications, the audio decoder may be capable of simultaneously decoding two elementary streams containing different programme elements, and then combining the programme elements into a complete programme.

Most of the programme elements are found in the main audio service. Another programme element (such as a spoken narration of the picture content intended for the visually impaired listener, a specially created dialogue based audio service for the hearing impaired listener, or additional audio services such as a spoken director's commentary or alternative languages) may be found in an associated audio service.

In order to have the audio from the two elementary streams reproduced in exact sample synchronism, it is necessary for the original audio elementary stream encoders to have encoded the two audio programme elements frame synchronously; i.e. if audio stream 1 has sample 0 of frame n taken at time t_0 , then audio stream 2 should also have frame n beginning with its sample 0 taken the identical time t_0 . *If the encoding of multiple audio services is done frame and sample synchronous, and decoding is intended to be frame and sample synchronous, then the PES packets of these audio services shall contain identical values of PTS, which refer to the audio access units intended for synchronous decoding.*

Audio services intended to be combined together for reproduction according to the mixing process defined in TS 102 366 [12] (annex E) shall meet the following constraints:

- Audio services intended to be combined together for reproduction shall be encoded at an identical sample rate.
- The main programme audio shall be encoded as either an AC-3 or an Enhanced AC-3 elementary stream. The associated audio service shall be encoded as an Enhanced AC-3 elementary stream.
- The Enhanced AC-3 elementary stream carrying the associated audio service shall contain mixing metadata for use by the decoder to control the mixing process.
- When mixing metadata is present in the Enhanced AC-3 elementary stream, the AD_Descriptor defined in clause E.1 shall not be present in the PES encapsulation of the Enhanced AC-3 elementary stream.
- The main programme shall contain from 1 to 7.1 channels of audio. The Enhanced AC-3 elementary stream that carries the associated audio services to be mixed with the main programme audio shall contain no more than two audio channels, and shall not contain more audio channels than the main audio programme.
- Dual-mono coding mode is not supported for either the main programme or associated audio service.
- The encoding of the associated audio service and subsequent creation of the associated audio service elementary stream shall be done with knowledge of the encoding of the main programme stream.
- The *pgmscl* field in the associated programme bitstream should be set to a positive value. It is recommended this be positive 12 dB to match the default user volume adjustment setting in the decoder.

6.2.1.2 Decoding

If audio access units from two audio services which are to be simultaneously decoded have identical values of PTS indicated in their corresponding PES headers, then the corresponding audio access units shall be presented to the audio decoder for simultaneous synchronous decoding. Synchronous decoding means that for corresponding audio frames (access units), corresponding audio samples are presented at the identical time.

If the PTS values do not match (indicating that the audio encoding was not frame synchronous) then the audio frames (access units) of the main audio service may be presented to the audio decoder for decoding and presentation at the time indicated by the PTS. An associated service, which is being simultaneously decoded, may have its audio frames (access units), which are in closest time alignment (as indicated by the PTS) to those of the main service being decoded, presented to the audio decoder for simultaneous decoding. In this case the associated service may be reproduced out of sync by as much as 1/2 of a frame time. (This is typically satisfactory; a visually impaired narration does not require highly precise timing.)

A minimum functionality mixer is described in clause E.4 of TS 102 366 [12]. IRDs that implement this mixing method shall set the default user volume adjustment of the associated programme level to minus 12 dB.

The IRD may use the ISO 639 [27] language descriptor to indicate the language of the content of the associated programme. As the associated services are carried in separate elementary streams to the main service different languages may be indicated for each programme stream.

6.2.1.3 Byte-alignment

The AC-3 and Enhanced AC-3 elementary stream shall be byte-aligned within the MPEG-2 data stream. This means that the initial 8 bits of an AC-3 or Enhanced AC-3 frame shall reside in a single byte, which is carried by the MPEG-2 data stream.

6.2.2 Enhanced AC-3 with multiple independent substreams - PES constraints

6.2.2.1 Encoding

In some applications, the audio decoder may be capable of simultaneously decoding two different programme elements, carried as separate independent substreams within a single Enhanced AC-3 elementary stream, and then combining the programme elements into a complete programme.

Most of the programme elements are found in the main audio service. Another programme element (such as a spoken narration of the picture content intended for the visually impaired listener, a specially created dialogue based audio service for the hearing impaired listener or additional audio services such as a spoken director's commentary) may be found in one or more independent substreams carried in the same Enhanced AC-3 bitstream as the main programme.

The Enhanced AC-3 elementary stream shall contain no more than three independent substreams in addition to the independent substream containing the main audio programme. The main audio programme shall only be delivered in independent substream 0.

When mixing metadata is present in one of more substreams of the Enhanced AC-3 elementary stream, the AD_Descriptor defined in clause E.1 shall not be present in the PES encapsulation of the Enhanced AC-3 elementary stream.

In order to have the independent substreams containing audio from the main programme and the associated audio service reproduced in exact sample synchronism, it is necessary for the Enhanced AC-3 encoder to have encoded all of the audio programme elements frame synchronously; i.e. if the independent substream 0 has sample 0 of frame n taken at time t_0 , then independent substream 1 should also have frame n beginning with its sample 0 taken the identical time t_0 .

Independent substreams intended to be combined together for reproduction according to the mixing process defined in TS 102 366 [12] (annex E) shall meet the following constraints:

- *Independent substreams intended to be combined together for reproduction shall be encoded at an identical sample rate.*
- *The independent substream carrying the associated audio service shall contain mixing metadata for use by the decoder to control the mixing process.*
- *The independent substream that carries the main programme shall contain from 1 to 5.1 channels of audio. The independent substream that carries the associated audio services to be mixed with the main programme audio shall contain no more than two audio channels, and shall not contain more audio channels than the main audio programme.*
- *Dual-mono coding mode is not supported for either the main programme or associated audio service.*
- *The encoding of the associated audio service and subsequent creation of the associated audio service substream shall be done with knowledge of the encoding of the main programme substream.*
- *The pgmscl field in the associated programme substream should be set to a positive value. It is recommended this be positive 12 dB to match the default user volume adjustment setting in the decoder.*

6.2.2.2 Decoding

IRDs shall be able to accept Enhanced AC-3 elementary streams that contain more than one independent substream.

For TV-broadcasting applications, noticeably public service broadcasting, there is often a requirement for commentary or narration audio services to provide for different languages or Visually Impaired or Hearing Impaired audiences. To allow cost effective transmission and reproduction of these services it is strongly recommended that IRDs be able to select additional independent substreams carried in an Enhanced AC-3 elementary stream and mix the selected independent substream with the main audio programme. A minimum functionality mixer is described in clause E.4 of TS 102 366 [12]. *IRDs that include this mixing capability shall set the default user volume adjustment of the associated programme level to minus 12 dB.*

The IRD may use the ISO 639 [27] language descriptor to indicate the language of the content of the main programme. As the associated programmes are carried in the same elementary stream as the main programme, the IRD shall assume that the language of associated programmes carried in independent substreams is the same as that of the main programme. *To deploy associated programmes with different languages than the main programme, separate Enhanced AC-3 elementary streams shall be used, as described in clauses 6.2.1.1 and 6.2.1.2.*

IRDs that support multiple different output-interfaces, for example headphone output or baseband analogue outputs, may optionally support separate mixes for each output created by multiple Enhanced AC-3 decoders.

6.3 DTS audio

The coding and decoding of DTS coded elementary streams is based upon TS 102 114 [15].

IRDs compatible with DTS audio shall decode all bitrates and sample rates listed in TS 102 114 [15].

Some constraints are placed on the PES layer for the case of multiple audio streams intended to be reproduced in exact sample synchronism as described in clause 6.3.1.

6.3.1 DTS and DTS-HD PES Constraints

6.3.1.1 Encoding

In some applications, the audio decoder may be capable of simultaneously decoding two elementary streams containing different programme elements, and then combining the programme elements into a complete programme.

Most of the programme elements are found in the main audio service. Another programme element (such as a narration of the picture content intended for the visually impaired listener) may be found in the associated audio service.

In order to have the audio from the two elementary streams reproduced in exact sample synchronism, it is necessary for the original audio elementary stream encoders to have encoded the two audio programme elements frame synchronously; i.e. if audio stream 1 has sample 0 of frame n taken at time t_0 , then audio stream 2 should also have frame n beginning with its sample 0 taken the identical time t_0 . *If the encoding of multiple audio services is done frame and sample synchronous, and decoding is intended to be frame and sample synchronous, then the PES packets of these audio services shall contain identical values of PTS, which refer to the audio access units intended for synchronous decoding.*

Audio services intended to be combined together for reproduction shall be encoded at an identical sample rate.

6.3.1.2 Decoding

If audio access units from two audio services which are to be simultaneously decoded have identical values of PTS indicated in their corresponding PES headers, then the corresponding audio access units shall be presented to the audio decoder for simultaneous synchronous decoding. Synchronous decoding means that for corresponding audio frames (access units), corresponding audio samples are presented at the identical time.

If the PTS values do not match (indicating that the audio encoding was not frame synchronous) then the audio frames (access units) of the main audio service may be presented to the audio decoder for decoding and presentation at the time indicated by the PTS. An associated service, which is being simultaneously decoded, may have its audio frames (access units), which are in closest time alignment (as indicated by the PTS) to those of the main service being decoded, presented to the audio decoder for simultaneous decoding. In this case the associated service may be reproduced out of sync by as much as 1/2 of a frame time. (This is typically satisfactory; a visually impaired narration does not require highly precise timing.)

6.3.1.3 Byte-alignment

The DTS and DTS-HD elementary streams shall be byte-aligned within the MPEG-2 data stream. This means that the initial 8 bits of a DTS/DTS-HD frame shall reside in a single byte, which is carried by the MPEG-2 data stream.

6.4 MPEG-4 AAC, MPEG-4 HE AAC and MPEG-4 HE AAC v2 audio

The coding and decoding of MPEG-4 AAC, MPEG-4 HE AAC and MPEG-4 HE AAC v2 elementary streams is based upon ISO/IEC 14496-3 [17].

The MPEG-4 AAC and the MPEG-4 High Efficiency AAC Profiles are subsets of the MPEG-4 High Efficiency AAC v2 profile. HE AAC adds the AOT SBR to the MPEG-4 AAC Profile. HE AAC v2 adds the AOT PS to the MPEG-4 High Efficiency AAC profile to improve the audio quality at low bitrates. Every HE AAC decoder can decode an HE AAC v2 bitstream, but will not be able to use the parametric stereo information and will therefore replay on a mono signal.

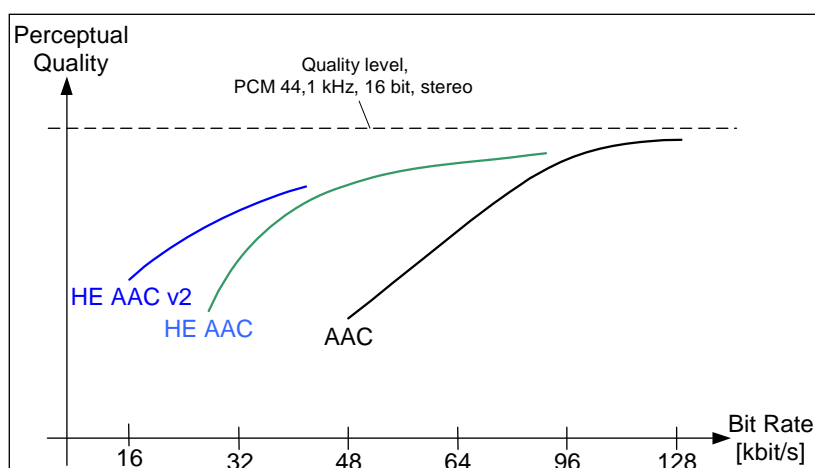

Figure 2: Typical bitrate range of the HE AAC v2, HE AAC and AAC for stereo

Figure 2 indicates the typical bitrate ranges for the use of MPEG-4 HE AAC v2, MPEG-4 HE AAC and MPEG-4 AAC on the encoder side for stereo. The actual bitrates for the use of the different tools is dependent from the encoder implementation.

Optionally, also the combination of MPEG-4 AAC, MPEG-4 HE AAC and MPEG-4 HE AAC v2 with MPEG Surround is supported. The encoding and decoding of MPEG Surround complies with ISO/IEC 23003-1:2007 [29] and ISO/IEC 23003-1:2007/Cor:2008 [30]. MPEG Surround creates a (mono or stereo) downmix from the multi-channel audio input signal. This downmix is encoded using a core audio codec, in this case MPEG-4 AAC, HE AAC or HE AAC v2. In addition, MPEG Surround generates a spatial image parameter description of the multi channel audio that is added as an ancillary data stream to the core audio codec. Legacy mono or stereo decoders ignore the ancillary data and playback a stereo respectively mono audio signal. MPEG Surround capable decoders will first decode the mono or stereo core codec audio signal and then use the spatial image parameters extracted from the ancillary data stream to generate a high quality multi channel audio signal.

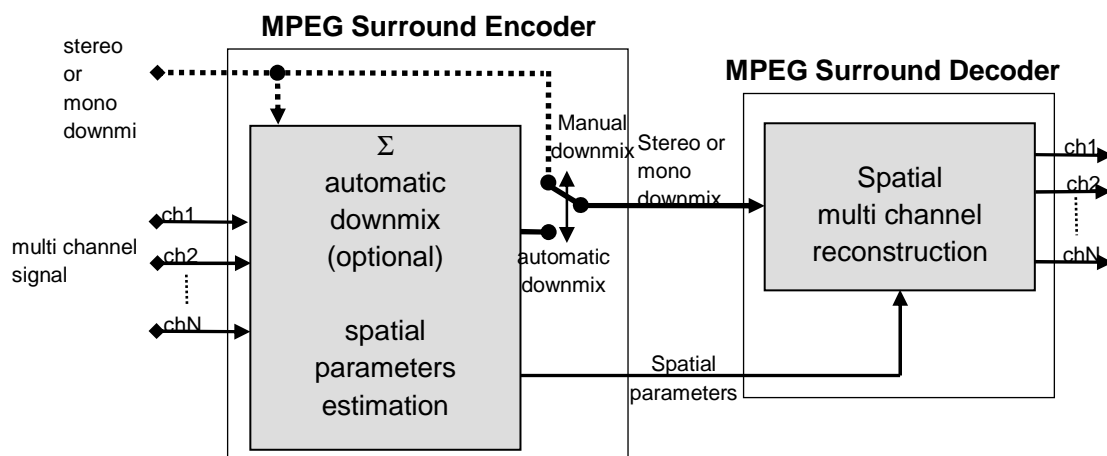

Figure 3: Principle of MPEG Surround, the downmix is coded using MPEG-4 AAC, HE AAC or HE AAC v2

6.4.1 LATM/LOAS formatting

The MPEG-4 HE AAC or HE AAC v2 elementary stream data shall be first encapsulated in the LATM multiplex format according to ISO/IEC 14496-3 [17].

When MPEG Surround is used then the combination of MPEG Surround as specified in ISO/IEC 23003-1 [29] and [31] with MPEG-4 AAC, MPEG-4 HE AAC or MPEG-4 HE AAC v2 as specified in ISO/IEC 14496-3 [17] is transmitted using LOAS/LATM, being also specified in ISO/IEC 14496-3 [17]. First, the combined MPEG-4 AAC/MPEG Surround, MPEG-4 HE AAC/MPEG Surround or MPEG-4 HE AAC v2/MPEG Surround shall be formatted using the LATM multiplex format.

The **AudioMuxElement()** multiplex element format shall be used.

The LATM formatted MPEG-4 HE AAC or HE AAC v2 elementary stream data shall be encapsulated in the LOAS transmission format according to ISO/IEC 14496-3 [17]. The **AudioSyncStream()** version shall be used.

AudioSyncStream() adds a sync word to the audio stream to allow for synchronization. Semantics: The semantics of the **AudioMuxElement()** and **AudioSyncStream()** formatting are described in ISO/IEC 14496-3 [17].

Encoding: The MPEG-4 HE AAC and HE AAC v2 elementary streams shall be formatted with **AudioMuxElement()** LATM multiplex format, and **AudioSyncStream()** LOAS transmission format.

The MPEG-4 AAC/MPEG Surround, MPEG-4 HE AAC/MPEG Surround and MPEG-4 HE AAC v2/MPEG Surround elementary streams shall be formatted with **AudioMuxElement()** LATM multiplex format, and **AudioSyncStream()** LOAS transmission format.

The following limitations to the LATM multiplex shall apply:

- **audioMuxVersion** shall be "0";
- **numLayer** shall be "0", as no scalable profile is used; When MPEG Surround is used this indicates that a single layer is present consisting of MPEG-4 AAC, MPEG-4 HE AAC or MPEG-4 HE AAC v2 with embedded MPEG Surround data;
- **numProgram** shall be "0", as there is only one audio program per LATM multiplex;
- **numSubFrames** shall be "0", as there is only one **PayloadMux()** (access unit) per LATM **AudioMuxElement()**;
- **allStreamsSameTimeFraming** shall be "1", as all payloads belong to the same access unit;

- the fields **taraBufferFullness** and **latmBufferFullness** shall be set to their largest respective value, indicating that buffer fullness measures are not used in DVB context;
- the value for **frameLengthFlag** contained in the **GASpecificConfig** shall be set to 0, indicating that the transform length of the IMDCT for AAC is 1024 samples for long and 128 for short blocks.

In case of the combination MPEG-4 AAC with MPEG Surround, the Audio Object Type (AOT) element, **audioObjectType** , shall be set to the value 2 (indicating AAC LC).

In case of the combination MPEG-4 HE AAC with MPEG Surround or the combination of MPEG-4 HE AAC v2 with MPEG Surround, the Audio Object Type (AOT) element, **audioObjectType** , shall be set to the value 5 (indicating SBR). Furthermore, separate fill elements shall be employed to embed the SBR(/PS) extension data elements **sbr_extension_data()** , described in ISO/IEC 14496-3 [17], and MPEG Surround spatial audio data **SpatialFrame()** , described in ISO/IEC 23003-1 [29] and [31].

The spatial frame length, indicated by the **bsFrameLength** parameter, shall correspond to the MPEG-4 AAC frame length. Hence, the **bsFrameLength** shall be any of the following values: {15, 31, 63}, resulting in effective MPEG Surround frame lengths of 1 024, 2 048 and 4 096 time domain samples respectively.

Decoding: These formats shall be read by the IRD, and the IRD shall interpret these formats in accordance with MPEG-4 audio syntax.

In case the IRD supports MPEG Surround decoding, these formats shall be read by the IRD, and the IRD shall interpret these formats in accordance with MPEG-4 and MPEG Surround audio syntax.

6.4.2 Profiles and Levels

6.4.2.1 Profiles and Levels for AAC, HE AAC and HE AAC v2

MPEG-4 AAC, HE AAC and HE AAC v2 are defined in ISO/IEC 14496-3 [17] section 1.5.2. as AAC Profile, High Efficiency AAC Profile and High Efficiency AAC v2 Profile respectively.

Encoding: The encoder shall use either the MPEG-4 AAC Profile, the MPEG-4 High Efficiency AAC Profile or the MPEG-4 High Efficiency AAC v2 Profile. Use of the MPEG-4 HE AAC Profile is recommended.

Monaural, stereo and parametric stereo MPEG-4 HE AAC v2 bitstreams shall comply with level 2 restrictions.

Monaural and stereo MPEG-4 AAC and HE AAC bitstreams shall comply with level 2 restrictions, respectively.

Multichannel audio up to 5.1 channel bitstreams shall comply with the level 4 restrictions respectively. Coupling Channel Elements (CCEs) according to ISO/IEC 14496-3 [17] shall not be used.

Decoding: The IRD, if compatible with MPEG-4 AAC audio, shall be capable of decoding MPEG-4 AAC, MPEG-4 High Efficiency AAC or the MPEG-4 High Efficiency AAC v2 Profile bitstreams.

A MPEG-4 HE AAC v2 monaural, stereo and parametric stereo enabled decoder shall support decoding MPEG-4 HE AAC v2 Profile Level 2 bitstreams. This requirement does include support for lower levels, but not other profiles. Support for other profiles and for levels beyond Level 2 is optional.

A MPEG-4 AAC and HE AAC monaural and stereo enabled decoder shall support decoding MPEG-4 High Efficiency AAC Profile Level 2 bitstreams. This requirement does include support for lower levels, but not other profiles. Support for other profiles and for levels beyond Level 2 is optional.

MPEG-4 AAC, HE AAC or HE AAC v2 multi-channel enabled decoder shall support decoding MPEG-4 AAC Profile, MPEG-4 High Efficiency AAC Profile or High Efficiency AAC v2 Profile Level 4 bitstreams respectively. This requirement does include support for lower levels, but not other profiles. Support for other profiles and for levels beyond Level 4 is optional. Support for Coupling Channel Elements (CCEs) according to ISO/IEC 14496-3 [17] is optional. If an IRD supports higher levels than level 2 then it shall also support Matrix-Mixdown according to ISO/IEC 14496-3 [17], section 4.5.1.2.2. It shall further support the application of downmixing_levels_MPEG4 in ancillary data (annex C).

6.4.2.2 Profiles and Levels for MPEG Surround in combination AAC, HE AAC and HE AAC v2

The Baseline MPEG Surround Profile is defined in ISO/IEC 23003-1 [29] and ISO/IEC 23003-1:2007/Cor:2008 [30]. For the combination of MPEG Surround with MPEG-4 AAC, MPEG-4 HE AAC or MPEG-4 HE AAC v2, the Baseline MPEG Surround Profile will be employed together with the AAC Profile, High Efficiency AAC Profile or High Efficiency AAC v2 Profile respectively. *The AAC or HE AAC or HE AAC v2 bitstream payloads shall comply with level 2 or level 4 of the respective profile. The MPEG Surround bitstream payload shall comply with level 3, 4 or 5 of the Baseline MPEG Surround profile.*

Encoding: *In combination with MPEG Surround, MPEG-4 AAC, MPEG-4 HE AAC or MPEG-4 HE AAC v2 bitstream payloads shall comply with the restrictions of level 2 of their respective profile. If the MPEG Surround bitstream payload complies to Level 5 of the Baseline MPEG Surround profile, bitstream payloads shall comply to Level 4 of the AAC or HE_AAC profile.*

Decoding: *The IRD, if compatible with MPEG-4 HE AAC audio at Level 4 and capable of decoding MPEG Surround and capable of providing 7.1 channels or more of output, shall be capable of providing decoder output according to MPEG Surround Baseline profile level 5.*

The IRD, if compatible with MPEG-4 HE AAC audio up to Level 3 and capable of decoding MPEG Surround and capable of providing 7.1 channels or more of output, shall be capable of providing decoder output according to MPEG Surround Baseline profile level 4.

The IRD, if compatible with MPEG-4 HE AAC audio and capable of decoding MPEG Surround and capable of providing more than two and up to 5.1 channels of output shall be capable of providing decoder output according to MPEG Surround Baseline profile level 3.

The IRD, if compatible with MPEG-4 HE AAC audio and capable of decoding MPEG Surround and capable of providing up to 2.0 channels of output shall be capable of providing decoder output according to MPEG Surround Baseline profile level 1.

6.4.3 Dynamic Range Control

The MPEG-4 AAC Dynamic Range Control (DRC) tool is defined in ISO/IEC 14496-3 [17], clause 4.5.2.7. For more detailed information on the MPEG-4 AAC Dynamic Range Control tool see ISO/IEC 14496-3 [17].

Encoding: *It is strongly recommended that the encoder uses the MPEG-4 AAC Dynamic Range Control (DRC) tool.*

Decoding: *The IRD shall support the MPEG-4 AAC Dynamic Range Control (DRC). If a program reference level is not transmitted in the bitstream, it is strongly recommended that a program reference level of -23 dB is assumed.*

It is strongly recommended that each IRD operates either at a target level of -23 dB or at a target level of -31 dB.

Details of how Dynamic Range Control should be applied are specified in annex C.5.4 .

Annex A (informative): Examples of Full screen luminance resolutions for SDTV and 25 Hz /30 Hz HDTV

Table A.1: Examples of MPEG-2 screen resolution

vertical_size value	horizontal_size value	aspect_ratio information	frame_rate code (see note)	Progressive or Interlace	Decodeable by MPEG-2 SDTV IRD
1 080	1 920	16:9	25	P	N
1 080	1 920	16:9	23,976, 24, 29,97, 30	P	N
1 080	1 920	16:9	25	I	N
1 080	1 920	16:9	29,97, 30	I	N
720	1 280	16:9	25, 50	P	N
720	1 280	16:9	23,976, 24, 29,97, 30, 59,94, 60	P	N
576	720	16:9	50	P	N
576	720	4:3, 16:9	25	P	Y
576	720	4:3, 16:9	25	I	Y
576	544	4:3, 16:9	25	P	Y
576	544	4:3, 16:9	25	I	Y
576	480	4:3, 16:9	25	P	Y
576	480	4:3, 16:9	25	I	Y
576	352	4:3, 16:9	25	P	Y
576	352	4:3, 16:9	25	I	Y
480	720	16:9	59,94, 60	P	N
480	720	4:3, 16:9	23,976, 24, 29,97, 30	P	Y
480	720	4:3, 16:9	29,97, 30	I	Y
480	640	4:3	23,976, 24, 29,97, 30	P	Y
480	640	4:3	29,97, 30	I	Y
480	544	4:3, 16:9	23,976, 29,97	P	Y
480	544	4:3, 16:9	29,97	I	Y
480	480	4:3, 16:9	23,976, 29,97	P	Y
480	480	4:3, 16:9	29,97	I	Y
480	352	4:3, 16:9	23,976, 29,97	P	Y
480	352	4:3, 16:9	29,97	I	Y
288	352	4:3, 16:9	25	P	Y
240	352	4:3, 16:9	23,976, 29,97	P	Y

NOTE: Shaded "frame_rate_code" values indicate 30 Hz bitstreams, clear values 25 Hz bitstreams.

Table A.2: Examples of H.264/AVC Screen Resolution

Vertical size	Horizontal size	Aspect ratio	Frame rate (see note)	Progressive or Interlaced	Decodable by H.264/AVC SDTV IRD
1 080	1 920, 1 440, 1 280, 960	16:9	23,976, 24	P	N
			25	I	N
			29,97, 30	P	N
			29,97, 30	I	N
720	1 280, 960, 640	16:9	25, 50	P	N
			23,976, 24, 29,97, 30, 59,94, 60	P	N
576	720	4:3, 16:9	25	P	Y
				I	Y
	544, 480, 352	4:3, 16:9	25	P	Y
				I	Y
480	720, 640, 544, 480, 352	4:3, 16:9	23,976, 24, 29,97, 30	P	Y
			29,97, 30	I	Y
288	352	4:3	25, 50	P	Y
			25	I	Y
240	352	4:3	23,976, 24, 29,97, 30, 59,94, 60	P	Y
			29,97, 30	I	Y

NOTE: Shaded "frame_rate_code" values indicate 30 Hz bitstreams, clear values 25 Hz bitstreams.

Table A.3: Examples of VC-1 screen resolution

Vertical size	Horizontal size	Aspect ratio	Frame rate (see note)	Progressive or Interlaced	Decodable by VC-1 SDTV IRD
1 080	1 920, 1 440, 1 280, 960	16:9	23,976, 24	P	N
			25	I	N
			29,97, 30	P	N
			29,97, 30	I	N
720	1 280, 960, 640	16:9	25, 50	P	N
			23,976, 24, 29,97, 30, 59,94, 60	P	N
576	720	4:3, 16:9	25	P	Y
				I	Y
	544, 480, 352	4:3, 16:9	25	P	Y
				I	Y
480	720, 640, 544, 480, 352	4:3, 16:9	23,976, 24, 29,97, 30	P	Y
			29,97, 30	I	Y
288	352	4:3	25, 50	P	Y
			25	I	Y
240	352	4:3	23,976, 24, 29,97, 30, 59,94, 60	P	Y
			29,97, 30	I	Y

NOTE: Shaded "frame_rate" values indicate 30 Hz bitstreams, clear values 25 Hz bitstreams.

Annex B (normative): Auxiliary Data in the Video Elementary Stream

B.1 Overview

Certain picture-related types of data may be carried in the video elementary stream. While the "outer wrapper" is codec dependent, the basic data structures are shared in common between MPEG-2, H.264/AVC, and VC-1. These picture-related data types include Active Format Description (AFD), bar data, North American-style closed captions and disparity for graphics placement in plano-stereoscopic 3DTV.

Transmission of these descriptions, and use of these descriptions by a receiver, are both optional.

B.2 Common Syntax and Semantics

The payload is identified by use of several identifier values. Each one specifies the underlying payload syntax. In the case of the **DVB1_data()** structure, there is an additional sub-identifier and several sub-structures are used.

Table B.1: Values for user_identifier

user_identifier	user_structure()
0x47413934 ('GA94')	DVB1_data()
0x44544731 ('DTG1')	afd_data()

NOTE: Values of the user_identifier are registered with SMPTE-RA.

user_identifier: A 32 bit field whose value indicates the contents of the **user_structure()** as indicated in table B.1.

user_structure(): This is a variable length data structure defined by the value of **user_identifier** and table B.1. The two possible structures are shown in tables B.2 and B.3.

Table B.2: Afd_data() Syntax

Syntax	No. of Bits	Identifier
afd_data() {		
'0'	1	bslbf
active_format_flag	1	bslbf
reserved (set to '00 0001')	6	bslbf
if (active_format_flag == 1) {		
reserved (set to '1111')	4	bslbf
active_format	4	bslbf
}		
}		

active_format_flag: A 1 bit flag. A value of "1" indicates that an active format is described in this data structure.

active_format: A 4 bit field describing the "area of interest" in terms of its aspect ratio within the coded frame.

Table B.3: DVB1_data() Syntax

Syntax	No. of Bits	Identifier
DVB1_data() {		
user_data_type_code	8	uimsbf
user_data_type_structure()		
}		

user_data_type_code: An 8-bit value that identifies the type of user data to follow in the **user_data_type_structure()**. The values are defined in table B.4.

Table B.4: Values for user_data_type_code

user_data_type_code	user_data_type_structure()
0x00 to 0x02	DVB Reserved
0x03	cc_data()
0x04	DVB Reserved
0x05	DVB Reserved
0x06	bar_data()
0x07	multi_region_disparity()
0x08 to 0xFF	DVB Reserved

user_data_type_structure: This is a variable length set of data defined by the value of **user_data_type_code** and table B.7 (bar data) or table B.9 (closed captions) or table B.14 (multi region disparity).

B.3 Active Format Description (AFD)

The AFD describes the portion of the coded video frame that is "of interest". It is intended for use in networks that deliver mixed formats to a heterogeneous receiver population. The format descriptions are informative in nature and are provided to assist receiver systems to optimize their presentation of video. The AFD may be supplemented by "bar data", which describes the size of either a pair of top and bottom bars ("letterbox") or a pair of side bars ("pillar-box"). This permits a display of either 4:3 or 16:9 aspect ratio to best display a picture of any aspect ratio.

The AFD is intended for use where there are compatibility problems between the source format of a programme, the format used for the transmission of that programme, and the format of the target receiver population. For example, a wide-screen production may be transmitted as a 14:9 letter-box within a 4:3 coded frame, thus optimized for the viewer of a 4:3 TV, but causing problems to the viewer of a wide screen TV. The appropriate AFD may be transmitted with the video to indicate to the receiver the "area of interest" of the image, thereby enabling a receiver to present the image in an optimum fashion (which will depend on the format and functionality of the receiving equipment combined with the viewer's preferences). In this example, the functionality provided by the AFD is analogous to (but different from) that provided by Wide Screen Signalling (WSS) described in EN 300 294 [14].

In addition, the AFD extends WSS by allowing the "area of interest" of a full-frame 16:9 (anamorphic) image to be described, for example to indicate that the centre 4:3 portion of the image has been protected such that a set-top box connected to a 4:3 set may perform a centre cut-out without removing any essential picture information.

The AFD itself does not describe the aspect ratio of the coded frame (as this is described elsewhere in the MPEG-2, H264/AVC, or SMPTE VC-1 video syntax).

B.3.1 Coded Frame in MPEG-2 Video

The **active_format** is used by the decoder in conjunction with the "source aspect ratio". The source aspect ratio is derived from the "Display Aspect Ratio" (DAR) signalled in the **aspect_ratio_information**, the **horizontal_size**, **vertical_size**, and **display_horizontal_size** and **display_vertical_size** if present (see ITU-T Recommendation H.262 / ISO/IEC 13818-2 [2]):

- If **sequence_display_extension()** is not present:

$$\text{source aspect ratio} = \text{DAR}$$

- If **sequence_display_extension()** is present:

$$\text{source aspect ratio} = \text{DAR} \times \frac{\text{display_horizontal_size}}{\text{display_vertical_size}} \times \frac{\text{vertical_size}}{\text{horizontal_size}}$$

B.3.2 Coded Frame in H264/AVC Video

The `active_format` is used by the receiver in conjunction with picture size and shape information as indicated in the "sequence parameter set Rbsp" and the `aspect_ratio_idc` field of the "VUI parameters". In particular, the picture width, picture height, frame cropping information, and sample aspect ratio are important for proper use of `active_format` (see ISO/IEC 14496-10 [16]).

The combination of source aspect ratio and `active_format` allows the receiver to identify whether the "area of interest" is the whole of the frame (e.g. source aspect ratio 16:9, `active_format` 16:9 center), a letterbox within the frame (e.g. source aspect ratio 4:3, `active_format` 16:9 center), or a "pillar-box" within the frame (e.g. source aspect ratio 16:9, `active_format` 4:3 center).

B.3.3 Coded Frame in VC-1 Video

The `active_format` is used by the decoder in conjunction with the sample aspect ratio signalled in a VC-1 elementary stream by means of the `ASPECT_RATIO` field in the sequence header as defined in SMPTE ST 421 [20].

The combination of sample aspect ratio and `active_format` allows the decoder to identify whether the "area of interest" is the whole of the frame (e.g. source aspect ratio 16:9, `active_format` 16:9 centre), a letterbox within the frame (e.g. source aspect ratio 4:3, `active_format` 16:9 centre), or a "pillar-box" within the frame (e.g. source aspect ratio 16:9, `active_format` 4:3 centre).

B.3.4 Common Semantics of AFD

The combination of source aspect ratio and `active_format` allows the decoder to identify whether the "area of interest" is the whole of the frame (e.g. source aspect ratio 16:9, `active_format` 16:9 centre), a letterbox within the frame (e.g. source aspect ratio 4:3, `active_format` 16:9 centre), or a "pillar-box" (see note) within the frame (e.g. source aspect ratio 16:9, `active_format` 4:3 centre).

NOTE: "Pillar-box" describes a frame that the image fails to fill horizontally, in the same way that a "Letterbox" describes a frame that the image fails to fill vertically.

Table B.5: Active_format

Active_format	Aspect ratio of the "area of interest"
0000	AFD unknown (see below)
0001	Reserved
0010	box 16:9 (top)
0011	box 14:9 (top)
0100	box > 16:9 (centre)
0101 to 0111	Reserved
1000	Active format is the same as the coded frame
1001	4:3 (centre)
1010	16:9 (centre)
1011	14:9 (centre)
1100	Reserved
1101	4:3 (with shoot and protect 14:9 centre)
1110	16:9 (with shoot and protect 14:9 centre)
1111	16:9 (with shoot and protect 4:3 centre)

AFD 0000 indicates that information is not available and is undefined. Unless bar data is available, DTV receivers and video equipment should interpret the active format as being the same as the coded frame. AFD "0000", when accompanied by bar data, signals that the image's aspect ratio is narrower than 16:9, but is not either 4:3 or 14:9. The bar data should be used to determine the extent of the image.

AFD "0100", which should be accompanied by bar data, signals that the image's aspect ratio is wider than 16:9, as is typically the case with widescreen features. The bar data should be used to determine the height of the image.

The complete set of Active Formats described in the present document is illustrated in table B.6. Note that for each format two example illustrations have been given, corresponding to the source aspect ratio of the coded frame being 4:3 and 16:9. The AFD may also be used with coded frames of other aspect ratios. For example a coded frame of 2.21:1 with active_format 10 would represent a 16:9 image centred (pillar-box) within a 2.21:1 frame.

The Active Formats are illustrated using the following diagrammatic representation.

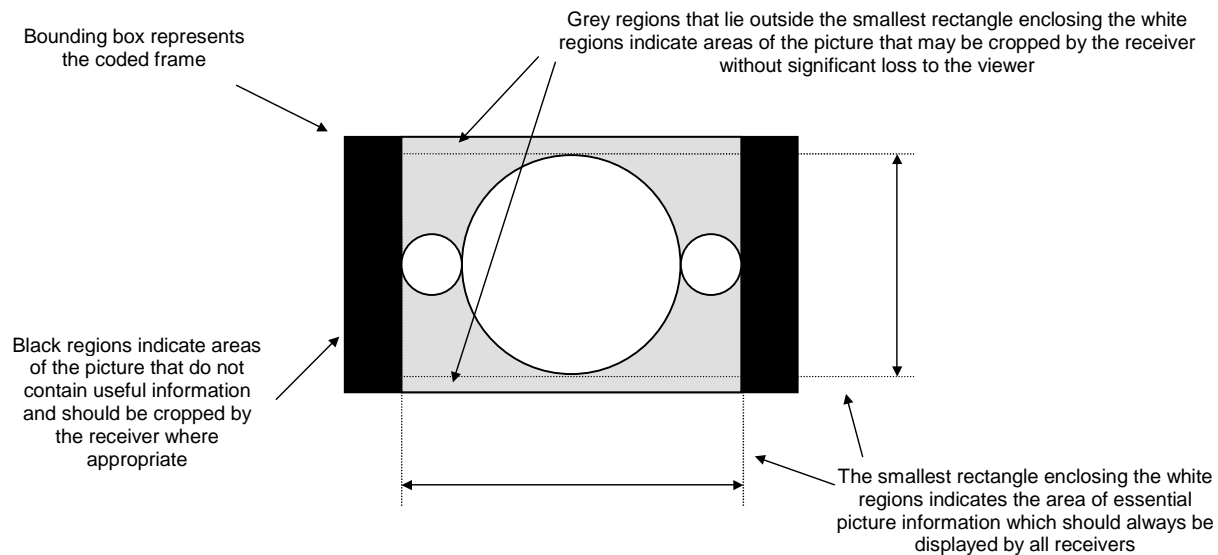
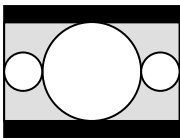
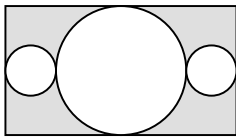
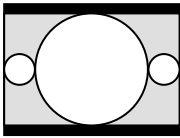
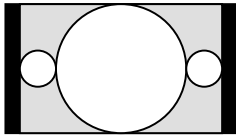
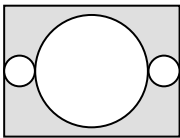
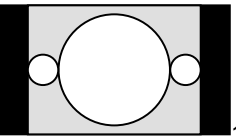
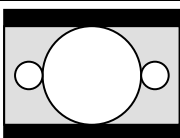
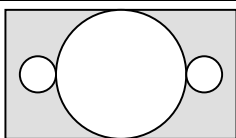
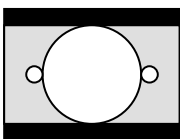
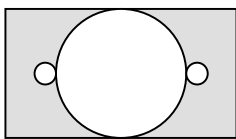

Figure B.1

Table B.6: Active Formats Illustrated

Active_format		Illustration of described format	
Value	Description	In 4:3 coded frame	In 16:9 coded frame
0000 to 0001	reserved		
0010	box 16:9 (top)		
0011	box 14:9 (top)		
0100	box > 16:9 (centre)		
0101 to 0111	reserved		
1000	As the coded frame		
1001	4:3 (centre)		 (see note)

Active_format		Illustration of described format	
Value	Description	In 4:3 coded frame	In 16:9 coded frame
1010	16:9 (centre)		
1011	14:9 (centre)		
1100	reserved		
1101	4:3 (with shoot and protect 14:9 centre)		
1110	16:9 (with shoot and protect 14:9 centre)		
1111	16:9 (with shoot and protect 4:3 centre)		
NOTE:		It is recommended to use the 4:3 coded frame mode to transmit 4:3 source material rather than using a pillar-box to transmit it in a 16:9 coded frame. This allows for higher horizontal resolution on both 4:3 and 16:9 sets.	

B.3.5 Relationship with Pan Vectors

Encoding: Encoded bitstreams may optionally include pan vectors and AFDs.

Decoding: The decoder may use the AFD as part of the logic that decides how the IRD processes and positions the reconstructed image for display on a monitor, where the monitor aspect ratio does not match the source aspect ratio (e.g. whether to use pan vectors, or generate a letterbox display).

B.4 Bar data

Table B.7 describes the syntax of bar data. Bar data should be included in video user data whenever the rectangular picture area containing useful information does not extend to the full height or width of the coded frame and AFD alone is insufficient to describe the extent of the image. See clause B.3.4.

Bar data is constrained (below) to be signalled in pairs, either top and bottom bars or left and right bars, but not both pairs at once. Bars may be unequal in size. One bar of a pair may be zero width or height.

Table B.7: Bar Data Syntax

Syntax	No. of Bits	Identifier
bar_data() {		
top_bar_flag	1	bslbf
bottom_bar_flag	1	bslbf
left_bar_flag	1	bslbf
right_bar_flag	1	bslbf
reserved (set to "1111")	4	bslbf
if (top_bar_flag == "1") {		
marker_bits (set to "11")	2	bslbf
line_number_end_of_top_bar	14	uimsbf
}		
if (bottom_bar_flag == "1") {		
marker_bits (set to "11")	2	bslbf
line_number_start_of_bottom_bar	14	uimsbf
}		
if (left_bar_flag == "1") {		
marker_bits (set to "11")	2	bslbf
pixel_number_end_of_left_bar	14	uimsbf
}		
if (right_bar_flag == "1") {		
marker_bits (set to "11")	2	bslbf
pixel_number_start_of_right_bar	14	uimsbf
}		
}		

Designation of line numbers for *line_number_end_of_top_bar* and *line_number_start_of_bottom_bar* is video format-dependent and shall conform to the applicable standard indicated in table B.8.

NOTE: The range of line numbers and pixels within the coded frame for each image format is specified in table 2 of SMPTE ST 2016-1:2009 [23].

Table B.8: Line Number Designation

Video Format	Applicable Standard
480 Interlaced 4:3	SMPTE ST 125 [i.8]
480 Interlaced 16:9	SMPTE ST 267 [i.10]
480 Progressive	SMPTE ST 293 [i.12]
720 Progressive	SMPTE ST 296 [i.13]
1 080 Interlaced	SMPTE ST 274 [i.11]
1 080 Progressive	SMPTE ST 274 [i.11]

top_bar_flag: This flag shall indicate, when set to "1", that the top bar data is present. If *left_bar_flag* is "1", this flag shall be set to "0".

bottom_bar_flag: This flag shall indicate, when set to "1", that the bottom bar data is present. This flag shall have the same value as *top_bar_flag*.

left_bar_flag: This flag shall indicate, when set to "1", that the left bar data is present. If *top_bar_flag* is "1", this flag shall be set to "0".

right_bar_flag: This flag shall indicate, when set to "1", that the right bar data is present. This flag shall have the same value as *left_bar_flag*.

line_number_end_of_top_bar: A 14-bit unsigned integer value representing the last line of a horizontal letterbox bar area at the top of the reconstructed frame. Designation of line numbers shall be as defined per each applicable standard in table B.8.

line_number_start_of_bottom_bar: A 14-bit unsigned integer value representing the first line of a horizontal letterbox bar area at the bottom of the reconstructed frame. Designation of line numbers shall be as defined per each applicable standard in table B.8.

pixel_number_end_of_left_bar: A 14-bit unsigned integer value representing the last horizontal luminance sample of a vertical pillar-box bar area at the left side of the reconstructed frame. *Pixels shall be numbered from zero, starting with the leftmost pixel.*

pixel_number_start_of_right_bar: A 14-bit unsigned integer value representing the first horizontal luminance sample of a vertical pillar-box bar area at the right side of the reconstructed frame. *Pixels shall be numbered from zero, starting with the leftmost pixel.*

additional_bar_data: Reserved for future DVB definition.

B.4.1 Recommended Receiver Response to Bar Data

Receiving device designers are strongly encouraged to study Consumer Electronics Association (CEA) bulletin CEB16 [24], which contains recommendations regarding the processing of bar data.

B.4.2 Relationship Between Bar Data and AFD

Certain combination of Active Format Description and bar data may be present in video user data (either, neither, or both). Note that AFD data may not always exactly match bar data because AFD only deals with 4:3, 14:9, and 16:9 aspect ratios while bar data can represent nearly any aspect ratio. When AFD and bar data are present together, AFD should be used in preference to bar data, except in the cases of AFD "0000" and "0100", where bar data should be used in concert with AFD as described above.

B.5 Closed Captions

The caption data, (as well as AFD and bar data) is carried in the user data of the video elementary stream.

The underlying structure, `cc_data()`, is common across MPEG-2, H.264/AVC, and VC-1.

B.5.1 Syntax and Semantics of `cc_data()`

The syntax for `cc_data()` is shown in table B.9.

Table B.9: `cc_data` Syntax

Syntax	No. of Bits	Identifier
<code>cc_data() {</code>		
reserved (set to '1')	1	bslbf
process_cc_data_flag	1	bslbf
zero_bit (set to '0')	1	bslbf
cc_count	5	uimsbf
reserved (set to '1111 1111')	8	bslbf
for (i=0 ; i < cc_count ; i++) {		
one_bit (set to '1')	1	
reserved (set to "1111")	4	
cc_valid	1	bslbf
cc_type	2	bslbf
cc_data_1	8	bslbf
cc_data_2	8	bslbf
}		
marker_bits = "11111111"	8	bslbf
}		

process_cc_data_flag: This flag is set to indicate whether it is necessary to process the `cc_data`. *If it is set to "1", the `cc_data` shall be parsed and its meaning processed. When it is set to "0", the `cc_data` shall be discarded.*

zero_bit: *This bit shall be "0" to maintain backwards compatibility with previous versions of CEA-708-C [26].*

cc_count: This 5-bit integer indicates the number of closed caption constructs following this field. It can have values 0 through 31. *The value of cc_count shall be set according to the frame rate and coded picture structure (field or frame) such that a fixed bandwidth of 9 600 bits per second is maintained for the closed caption payload data.* Sixteen (16) bits of closed caption payload data are carried in each pair of the fields **cc_data_1** and **cc_data_2**.

one_bit: This bit shall be "1" to maintain backwards compatibility with previous versions of CEA-708-C [26].

cc_valid: This flag is set to "1" to indicate that the two closed caption data bytes that follow are valid. If set to "0" the two data bytes are invalid, as defined in CEA-708-C [26].

cc_type: Denotes the type of the two closed caption data bytes that follow, as defined in CEA-708-C [26].

cc_data_1: The first byte of a closed caption data pair as defined in CEA-708-C [26].

cc_data_2: The second byte of a closed caption data pair as defined in CEA-708-C [26].

B.6 Auxiliary Data and MPEG-2 video

B.6.1 Coding

The Auxiliary Data (AFD, bar data, and caption data) is carried in the video elementary stream at the picture level as shown in table B.10. The repetition rate of the Auxiliary Data depends upon its payload.

*When present, caption data shall be carried in the data structure **cc_data()**, within the picture user data syntax as shown in table B.9, and shall be present for every picture. Receivers may ignore caption data.*

*When present, bar data shall be carried in the data structure **bar_data()**, within the picture user data syntax as shown in table B.7. After any **sequence_header()** such bar data shall appear before the next **picture_data()** within **extension_and_user_data(2)**. After introduction, such bar data shall remain in effect until:*

- 1) the next **sequence_header()**; or
- 2) **extension_and_user_data(2)** containing a **bar_data()** structure which contains new bar data; or
- 3) **extension_and_user_data(2)** containing AFD per clause B.3.4.

*After any **sequence_header()**, unless AFD data is present specifying otherwise, the absence of bar data shall indicate that the rectangular picture area containing useful information extends to the full height and width of the coded frame.*

B.6.2 Syntax and Semantics

Table B.10 is provided to show the syntax that is required for picture extension and user data (specifically **extension_and_user_data(2)**) as defined by MPEG-2 video (ISO/IEC 13818-2 [2]).

Table B.10: Auxiliary Data for MPEG-2 video

Syntax	No. of Bits	Identifier
user_data() {		
user_data_start_code	32	bslbf
user_identifier	32	bslbf
user_structure()		
}		

In accordance with the bit stream syntax in table B.10, more than one picture user data construct may follow any given picture header. *However, no more than one picture user data construct using the same **user_identifier** or **user_data_type_code** shall follow any given picture header.*

Receiving devices are expected to silently discard any unrecognized video user data encountered in the video bit stream. For example, if an unrecognized 32-bit identifier is seen following the **user_data_start_code**, or an unrecognized 8-bit **user_data_type_code** is seen following the **DVB_identifier**, data should be discarded until another start code is seen.

user_data_start_code: This shall be set to 0x0000 01B2 per ISO/IEC 13818-2 [2].

user_identifier: This is a 32 bit code that indicates the contents of the **user_structure()** as indicated in table B.1.

user_structure(): This is a variable length data structure defined by the value of **user_identifier** and table B.1.

B.7 Auxiliary Data and H264/AVC, MVC Stereo or SVC video

B.7.1 Coding

The Auxiliary Data is carried in the data as Supplemental Enhancement Information in H.264/AVC's "User data registered by ITU-T Recommendation T.35 [19] SEI message" syntactic element (see clauses D.8.5 and D.9.5 of ISO/IEC 14496-10 [16]).

Encoding: Support for the encoding of Auxiliary Data is optional.

Decoding: Support for the decoding of Auxiliary Data is optional.

B.7.2 Syntax and Semantics

The Auxiliary Data (AFD, bar data, caption data and multi_region_disparity) is carried in the video elementary stream as Supplemental Enhancement Information in H.264/AVC's "User data registered by ITU-T Recommendation T.35 SEI message" syntactic element [19]. The syntax of Auxiliary Data is illustrated in table B.11.

Table B.11: Active Format Description for H264/AVC video

user_data_registered_itu_t_t35(payloadSize) {	Descriptor	Notes
itu_t_t35_country_code	b(8)	0xB5
itu_t_t35_provider_code	u(16)	0x0031
user_identifier	f(32)	
user_structure()		
}		

itu_t_t35_country_code: This 8 bit field shall have the value 0xB5.

itu_t_t35_provider_code: This 16 bit field shall have the value 0x0031.

user_identifier: This is a 32 bit code that indicates the contents of the **user_structure()** as indicated in table B.1.

NOTE: In MPEG-2, the only discriminator within **user_data** is this 32-bit value. In the context of H.264/AVC, the value of **user_identifier** is used in addition to country and provider codes to definitively identify this as Auxiliary Data.

user_structure(): This is a variable length data structure defined by the value of **user_identifier** and table B.1.

B.7.3 Auxiliary Data in MVC Stereo HDTV Bitstreams

When present in MVC Stereo HDTV Bitstreams, the active format descriptor, bar data and closed caption data shall be the same for both base and dependent view bitstreams and may be transmitted in the MVC Stereo Base view bitstream.

When present in MVC Stereo HDTV Bitstreams, the *multi_region_disparity()* data shall be sent in the *user_data_registered_itu_t_135()* SEI message, which is contained in MVC scalable nesting SEI message of every MVC Stereo Dependent view component. When present in MVC Stereo HDTV Bitstreams, the multi region disparity data shall be present for every MVC Stereo Dependent view component.

B.8 Auxiliary Data and VC-1 video

B.8.1 Coding

The Auxiliary Data is carried in the user data of the video elementary stream as defined in SMPTE ST 421 [20]. After each sequence start (and repeat sequence start) the default aspect ratio of the area of interest is that signalled by the sequence header and sequence display extension parameters. When present, after introduction, an AFD or bar data persists until the next sequence start or until another AFD or different bar data is introduced.

Encoding: Support for the encoding of Auxiliary Data is optional.

The Auxiliary Data may be inserted in the video elementary stream as sequence level, entry-point level or frame level user data as specified in SMPTE ST 421 [20]. For example, it could be inserted once per sequence, once per entry-point, or once per frame. It may be changed for each frame. *Caption data, when present, shall be inserted once per frame.*

After introduction, such an AFD remains in effect until the next sequence start or until a new AFD is introduced.

Decoding: Support for the decoding of Auxiliary Data is optional.

A decoder that supports the decoding of Auxiliary Data shall be capable of decoding it from the sequence level, entry-point level and frame level locations specified in SMPTE ST 421 [20].

B.8.2 Syntax and Semantics

The Auxiliary Data is carried in the user data of the video elementary stream as defined in SMPTE ST 421 [20]. The syntax is illustrated in table B.12.

Table B.12: Auxiliary Data for VC-1 video

Syntax	No. of Bits	Identifier
user_data() {		
VC1_user_data_start_code	32	bslbf
user_identifier	32	bslbf
user_structure()		
}		

VC1_user_data_start_code: This 32-bit field shall be set to 0x0000011D to indicate the beginning of a user data structure in the VC-1 elementary stream.

user_identifier: This is a 32 bit code that indicates the contents of the **user_structure()** as indicated in table B.1.

user_structure(): This is a variable length data structure defined by the value of **user_identifier** and table B.1.

B.9 Relationship with Wide Screen Signalling (WSS)

The AFD and bar data provide a super-set of the aspect ratio signalling specified in EN 300 294 [14]. The mapping of source aspect ratio and active_format to WSS Aspect Ratio is given in table B.13.

Table B.13: Support for WSS

Sequence Header	Active Format Description	WSS	
source aspect ratio	value	code (Bits 0-3)	description
	1001	0001	full format 4:3
	1011	1000	box 14:9 Centre
	0011	0100	box 14:9 Top
4:3	1010	1101	box 16:9 Centre
	0010	0010	box 16:9 Top
	0100	1011	box > 16:9 Centre
	1101	0111	full format 4:3 (shoot and protect 14:9 Centre)
16:9	1010	1110	full format 16:9 (anamorphic)

As all-digital systems are constructed, there may remain legacy (or even regulatory) requirements to provide WSS support at some IRD outputs. It is recommended that transmission systems make use of SMPTE ST 2016-1:2009 [23] for signalling AFD and bar data in the incoming video, and that IRDs provide support for this on digital outputs.

Encoding: Incoming aspect ratio signalling (whether originating via WSS or AFD) should be placed in the video elementary stream per the present document. If desired, the encoder may also carry equivalent WSS data per EN 300 294 [14] in a separate PID.

Decoding: *IRDs shall pass AFD and bar data values to their digital video outputs.* Such values may be translated, per table B.13 into analog WSS waveforms for appropriate placement on analog outputs.

B.10 Aspect Ratio Ranges

The labels 4:3, 14:9, 16:9 and > 16:9 used in the AFD shall correspond to the aspect ratio ranges specified in EN 300 294 [14] (note that the corresponding active lines specified in EN 300 294 [14] do not, in general, apply).

B.11 Multi Region Disparity

This clause describes how to convey depth information in the form of disparity values so as to enable the overlay of additional information (graphics, menus, etc) such that a depth violation between the plano-stereoscopic video and graphics is avoided.

For each frame, one maximum disparity value is transmitted. Regions are defined according to a set of predefined image partitioning patterns. For each region of each frame, exactly one minimum disparity value is transmitted.

B.11.1 Syntax and Semantics of Multi Region Disparity

The syntax for `multi_region_disparity()` is shown in table B.14.

Table B.14: Multi Region Disparity Syntax

Syntax	No. of bits	Identifier
<code>multi_region_disparity() {</code>		
multi_region_disparity_length	8	uimsbf
if (((multi_region_disparity_length > 1) && (multi_region_disparity_length < 6)) (multi_region_disparity_length == 10) (multi_region_disparity_length == 17)) {		
number_of_regions = multi_region_disparity_length -1		
max_disparity_in_picture	8	tcimsbf
for (i=0; i<number_of_regions, i++) {		
min_disparity_in_region_i	8	tcimsbf
}		
} else if (multi_region_disparity_length == 0) {		
/* there is no disparity information to deliver */		
} else {		
for (i=0; i<N; i++) {		
reserved_for_future_use	8	bslbf
}		
}		
}		

multi_region_disparity_length: The `multi_region_disparity_length` is an 8-bit field specifying the number of bytes in the `multi_region_disparity()` immediately following the byte defining the value of this field. Furthermore, it signals the type of region pattern. The `multi_region_disparity_length` field has a limited set of values that correspond to predefined image partitioning patterns specified below in table B.15, all other values are prohibited or reserved for future use.

Each image partitioning pattern defines several regions of the image. *The boundaries between the regions shall be located at one quarter, one half and three quarters of the coded image width and height before cropping (for example, for images of size 1920x1080, the size 1920x1088 shall be used to determine the position of the boundaries in the transmitted picture).* The different region partitioning patterns are all based on these partition boundaries. Each region is identified by a number increasing from left to right and from top to bottom.

Table B.15: Meaning of multi_region_disparity_length

Value	Meaning of the value
0	no disparity information is to be delivered
1	Prohibited
2	one <code>minimum_disparity_in_region</code> is coded as representing the minimum value in overall picture (see figure B.3)
3	two vertical <code>minimum_disparity_in_regions</code> are coded (see figure B.4)
4	three vertical <code>minimum_disparity_in_regions</code> are coded (see figure B.5)
5	four <code>minimum_disparity_in_regions</code> are coded (see figure B.6)
6 to 9	reserved for future use
10	nine <code>minimum_disparity_in_regions</code> are coded (see figure B.7)
11 to 16	reserved for future use
17	sixteen <code>minimum_disparity_in_regions</code> are coded (see figure B.2)
18 to 255	reserved for future use

NOTE 1: Each region is made up to align to the 4 x 4 partition boundaries as shown in figure B.2. The patterns defined in figures B.3 to B.7 are based on the pattern from figure B.2 by spatially combining some of the regions.

NOTE 2: When `multi_region_disparity_length` is set to 0, the IRD is recommended to use a safer display method while graphics are present, to avoid viewer's eye strain. One of the safer display methods is to switch video to 2D, while graphics are overlaid onto the video with a slight disparity, which can retain a viewer's 3D experience.

NOTE 3: The value of `multi_region_disparity_length` should not be modified within an event, except to switch to the value '0' on a frame-by-frame basis to indicate that no disparity value is signalled for a picture.

max_disparity_in_picture: this field specifies the maximum disparity value in a picture. The value signalled is a two's complement integer in the range [-128, +127].

min_disparity_in_region_i: this field specifies the minimum disparity value in region i. The value signalled is a two's complement integer in the range [-128, +127]. The identifier i for each region depends on the value of `multi_region_disparity_length`. Figures B.2 to B.7 show the regions and their associated number for each allowed pattern.

The disparity value is the difference between the horizontal positions of a pixel representing the same point in space in the right and left views. The difference is given in number of pixels relative to a screen with a horizontal size of 1920 pixels. Particularly, if right position minus left position is a positive value, it refers to a point behind the display screen, and if it is a negative value, it refers to a point in front of the display screen. Max (maximum) disparity gives the farthest, while min (minimum) disparity gives the closest point in depth.

region 0 [R0]	region 1 [R1]	region 2 [R2]	region 3 [R3]
region 4 [R4]	region 5 [R5]	region 6 [R6]	region 7 [R7]
region 8 [R8]	region 9 [R9]	region 10 [R10]	region 11 [R11]
region 12 [R12]	region 13 [R13]	region 14 [R14]	region 15 [R15]

Figure B.2: Size and position of regions for `multi_region_disparity_length = 17`

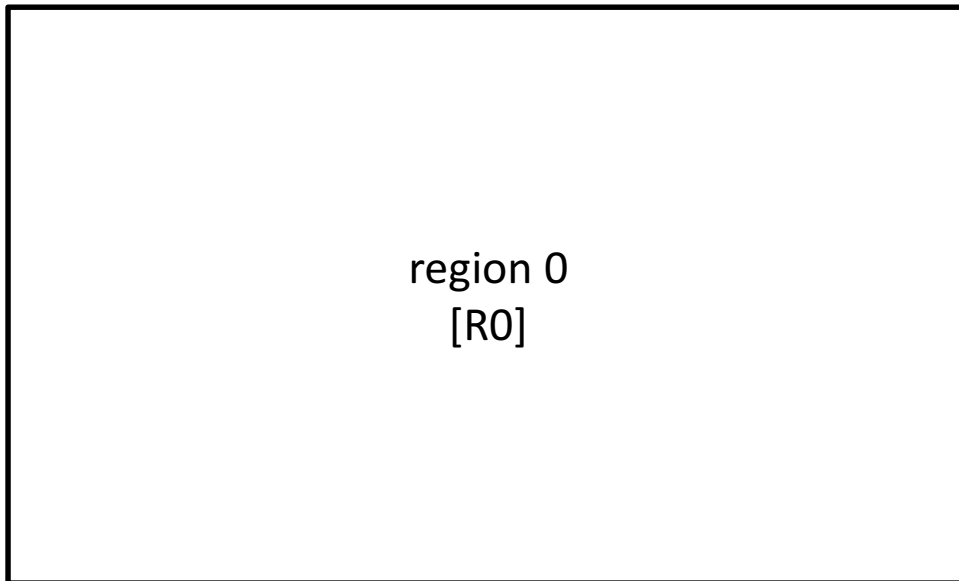

Figure B.3: Size and position of regions for multi_region_disparity_length = 2

NOTE: R0 spatially encompasses all the regions defined in figure B.2.

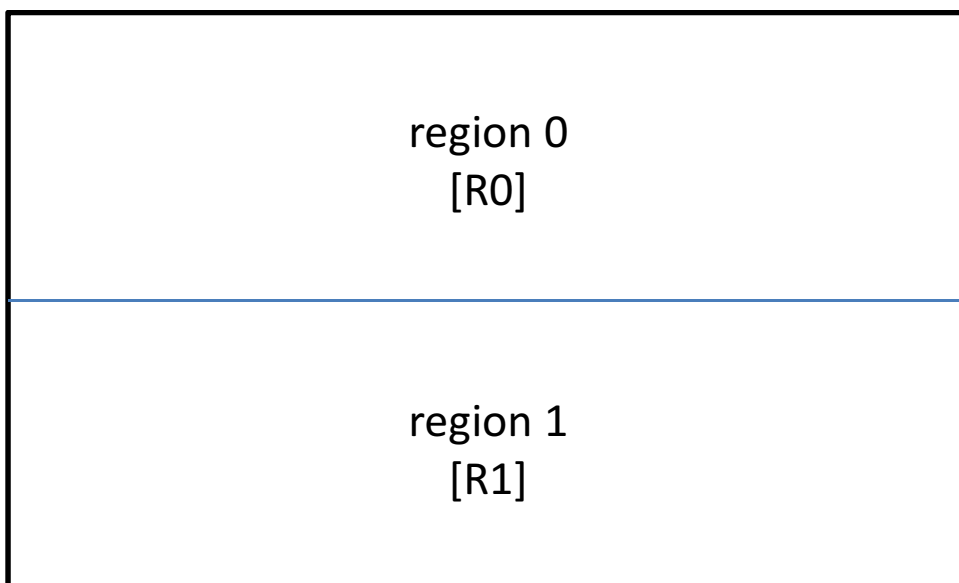

Figure B.4: Size and position of regions for multi_region_disparity_length = 3

NOTE: R0 spatially encompasses the regions R0 to R7 defined in figure B.2 and R1 spatially encompasses the regions R8 to R15 defined in figure B.2.

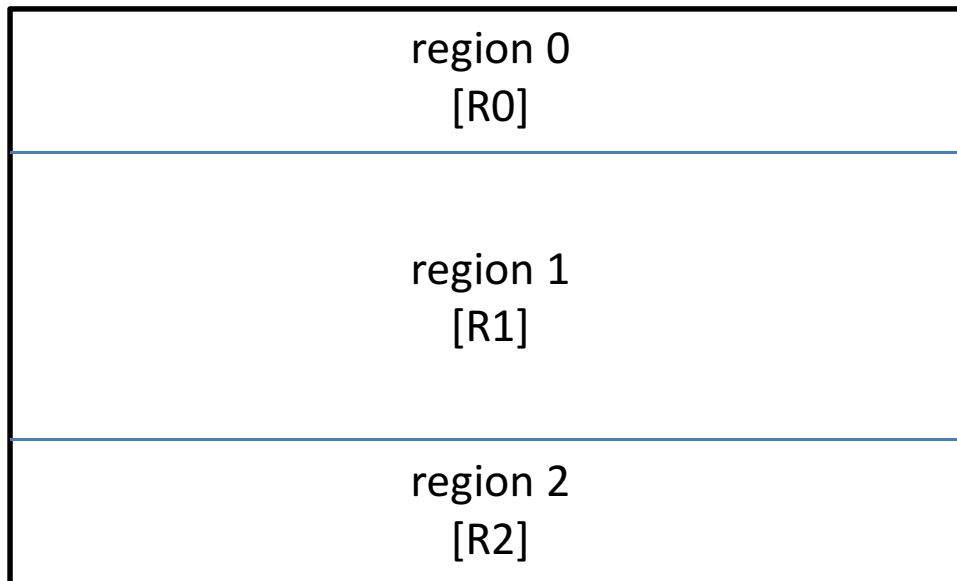

Figure B.5: Size and position of regions for multi_region_disparity_length = 4

NOTE: R0 spatially encompasses the regions R0 to R3 defined in figure B.2, R1 spatially encompasses the regions R4 to R11 defined in figure B.2 and R2 spatially encompasses the regions R12 to R15 defined in figure B.2.

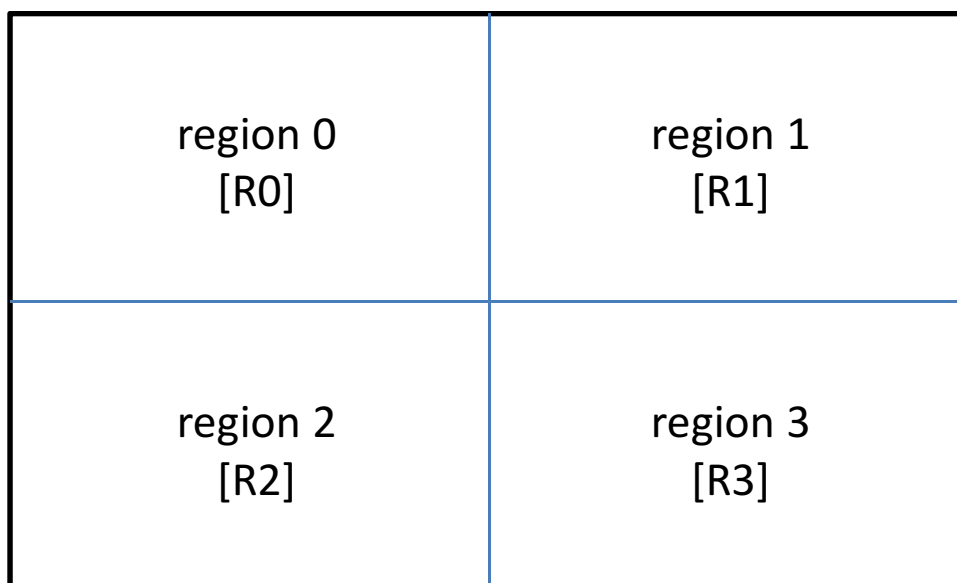

Figure B.6: Size and position of regions for multi_region_disparity_length = 5

NOTE: R0 spatially encompasses the regions R0, R1, R4, R5 defined in figure B.2, R1 spatially encompasses the regions R2, R3, R6, R7 defined in figure B.2, R2 spatially encompasses the regions R8, R9, R12, R13 defined in figure B.2 and R3 spatially encompasses the regions R10, R11, R14, R15 defined in figure B.2.

region 0 [R0]	region 1 [R1]	region 2 [R2]
region 3 [R3]	region 4 [R4]	region 5 [R5]
region 6 [R6]	region 7 [R7]	region 8 [R8]

Figure B.7: Size and position of regions for multi_region_disparity_length = 10

NOTE: R0 is identical to the region R0 defined in figure B.2, R1 spatially encompasses the regions R1 and R2 defined in figure B.2, R2 is identical to the region R3 defined in figure B.2, R3 spatially encompasses the regions R4 and R8 defined in figure B.2, R4 spatially encompasses the regions R5, R6, R9, R10 defined in figure B.2, R5 spatially encompasses the regions R7 and R11 defined in figure B.2, R6 is identical to the region R12 defined in figure B.2, R7 spatially encompasses the regions R13 and R14 defined in figure B.2 and R8 is identical to the region R15 defined in figure B.2.

Annex C (normative): Implementation of Ancillary Data for MPEG Audio

C.1 Scope

This annex contains the guidelines required to include ancillary data in the MPEG Audio elementary stream.

The IRD design should be made under the assumption that any structure as permitted by this annex may occur in the broadcast stream. The IRD is not required to make use of this data but its use is recommended.

C.2 Introduction

An MPEG audio elementary stream provides for the inclusion of ancillary data. This data can be used to convey specific information about the audio content to the decoder, allowing the broadcaster to control rendering of the content to a greater extent. The data includes dynamic range control information and dialogue normalization information.

In case of MPEG1 streams or MPEG2 streams without an extension stream (MPEG audio format 1), ancillary data described in this annex is placed at the end of each base frame.

In case of MPEG2 streams with extension stream (MPEG audio format 2), the ancillary data described in this annex is placed at the end of each base frame.

In case of MPEG4 streams in LATM/LOAS format, the ancillary data described in this annex is placed into **data_stream_element()** (see ISO/IEC 14496-3 [17], table 4.10).

C.3 DVB Compliance

The ancillary data format described in this annex does not introduce any additional elements to the DVB transport stream. It is compliant with the current specification and compatible with all MPEG audio decoders.

Presence and type of ancillary data in audio elementary streams is signalled in DVB SI Program Map Table by the "Ancillary data descriptor" (see EN 300 468 [6], clause 6.2.2).

C.4 Detailed specification for MPEG1 and MPEG2

C.4.1 DVD-Video Ancillary Data

The transmission of "dynamic_range_control" in MPEG1 Layer I/II and MPEG2 Layer I audio is optional. *If applied, 16 bits of ancillary data [b15.b0] (situated at the end of each MPEG audio base frame) shall be used.*

Table C.1: DVD-Video ancillary data syntax

Syntax	No. of Bits	Mnemonic
dvd_ancillary_data() {		
dynamic_range_control	8	bslbf
dynamic_range_control_on	1	bslbf
reserved (set to "000 0000b")	7	bslbf
}		

Semantics: The 8-bit `dynamic_range_control` field leads to the following gain control value by considering the upper 3 bits as unsigned integer X and the binary value of the lower 5 bits as unsigned integer Y :

- linear: $G = 2^{4-(X + Y/30)}$
($0 \leq X \leq 7, 0 \leq Y \leq 29$)
- in dB: $G = 24,082 - 6,0206 X - 0,2007 Y$
($0 \leq X \leq 7, 0 \leq Y \leq 29$)

If the `dynamic_range_control_on` field is set to "0b", the `dynamic_range_control` field does not convey useful information.

Encoding: When dynamic range control is temporarily not applied, that value of `dynamic_range_control` shall be set to "1000 0000b" or `dynamic_range_control_on` shall be set to "0b".

Decoding: The decoder shall read this field, and the decoder shall interpret the value G as a gain value applied to all sub band samples, before the reconstruction filter. This value may be scaled in the decoder to allow user control of the amount of dynamic range compression that is applied.

C.4.2 Extended ancillary data syntax

The syntax of the extended ancillary data field is described in table C.2.

The extended ancillary data is inserted beginning from the end of the base frame. It is recommended that it be parsed from the end. The description in table C.2 is in the reverse order of the transmission. The bit order in each byte is, however, such that the msb comes first in the transmission.

Table C.2: Extended ancillary data syntax

Syntax	No. of Bits	Mnemonic
extended_ancillary_data() {		
dvd_ancillary_data	16	bslfb
extended_ancillary_data_sync (set to 0xBC)	8	bslfb
bs_info	8	bslbf
ancillary_data_status	8	bslbf
if(advanced_dynamic_range_control_status == 1)		
advanced_dynamic_range_control	24	bslbf
if(dialog_normalization_status == 1)		
dialog_normalization	8	bslbf
if(reproduction_level_status == 1)		
reproduction_level	8	bslbf
if(downmixing_levels_MPEG2_status == 1)		
downmixing_levels_MPEG2	8	bslbf
if(audio_coding_mode_and_compression_status == 1) {		
audio_coding_mode	8	bslbf
Compression	8	bslbf
}		
if(coarse_grain_timecode_status == 1)		
coarse_grain_timecode	16	bslbf
if(fine_grain_timecode_status == 1)		
fine_grain_timecode	16	bslbf
if(scale_factor_CRC_status == 1)		
scale_factor_CRC	16 to 32	bslbf
}		

The elements of the ancillary data structure are described in the following clauses. The order of the bits is in transmission order, msb first.

C.4.2.1 ancillary_data_sync

Encoding: *This field shall be set to 0xBC.*

Decoding: The decoder may use this field to verify the availability of the extended ancillary data. If the IRD indicates that this information is present, this takes precedence.

C.4.2.2 bs_info

The detailed syntax is described in table C.3.

Table C.3: Bs_info syntax

Syntax	No. of Bits	Mnemonic
bs_info() {		
mpeg_audio_type	2	bslbf
dolby_surround_mode	2	bslbf
ancillary_data_bytes	4	uimsbf
}		

C.4.2.3 mpeg_audio_type

Table C.4: MPEG audio type Table

mpeg_audio_type	Description
"00"	Reserved
"01"	Only MPEG1 audio data
"10"	MPEG2 audio data
"11"	Reserved

Decoding: The decoder may ignore this field.

C.4.2.4 dolby_surround_mode

Table C.5: Dolby surround mode Table

mpeg_audio_type	Description
"00"	Reserved
"01"	MPEG1 part is not Dolby surround encoded
"10"	MPEG1 part is Dolby surround encoded
"11"	Reserved

Decoding: It is recommended that the decoder parse this field and provides this information to the reproduction set-up.

C.4.2.5 ancillary_data_bytes

This field indicates the amount of ancillary data bytes that precede this byte in the transmission. This field may be used by the decoder as an indication of how many bytes it needs to buffer.

C.4.2.6 ancillary_data_status

The detailed syntax is described on table C.6.

Table C.6: Ancillary_data_status syntax

Syntax	No. of Bits	Mnemonic
ancillary_data_status() {		
advanced_dynamic_range_control_status	1	bslbf
dialog_normalization_status	1	bslbf
reproduction_level_status	1	bslbf
downmix_levels_MPEG2_status	1	bslbf
scale_factor_CRC_status	1	bslbf
audio_coding_mode_and_compression_status	1	bslbf
coarse_grain_timecode_status	1	bslbf
fine_grain_timecode_status	1	bslbf
}		

Semantics: The bits in this field indicate the presence of the associated fields in the ancillary data.

Encoding: *A bit in this field shall be set to "1" if the associated field is present in the bitstream.*

Decoding: It is recommended that the decoder parse this field to allow parsing of the following fields in the ancillary data section.

C.4.2.7 advanced_dynamic_range_control

The detailed syntax is described on table C.7.

Table C.7: Advanced_dynamic_range_control syntax

Syntax	No. of Bits	Mnemonic
advanced_dynamic_range_control() {		
advanced_drc_part_0	8	bslbf
advanced_drc_part_1	8	bslbf
advanced_drc_part_2	8	bslbf
}		

Semantics: Each field consists of an unsigned integer value X in the three msb's and an unsigned integer value Y in the five lsb's. The actual value is $24,082 - 6,0206 X - 0,2007 Y$ dB. The 1 152 samples of an MPEG2 frame are divided in 3 parts of 384 samples. The advanced_drc values are applicable for the corresponding part of the audio frame.

Decoding: *If this field is present and the decoder supports this type of dynamic range control, these values shall be used rather than the DVD-Video ancillary data. The decoder shall apply these values to the sub band samples, before the reconstruction filter. These values may be scaled in the decoder to allow user control of the amount of dynamic range compression that is applied.*

C.4.2.8 dialog_normalization

The detailed syntax is described on table C.8.

Table C.8: Dialog_normalization syntax

Syntax	No. of Bits	Mnemonic
dialog_normalization() {		
dialog_normalization_on	2	bslbf
dialog_normalization_value	6	uimsbf
}		

C.4.2.8.1 dialog_normalization_on

Table C.9: Dialog normalization Table

dialog_normalization_on	Description
"00"	dialog_normalization_value is not valid
"01"	reserved
"10"	dialog_normalization_value is valid
"11"	Reserved

C.4.2.8.2 dialog_normalization_value

Semantics: This field represents the headroom in dB of the dialogue component in the MPEG1 compatible part, relative to full-scale sine wave. Values 41 through 63 are reserved. *When dialogue normalization is temporarily not applied, "Dialogue_Normalization_on" shall be set to "00" and "Dialog_Normalization_value" shall be set to "000000".*

Decoding: It is recommended that the decoder parse this field. The decoder should apply these values to the sub band samples, before the reconstruction filter, in order to allow reproduction of different programmes with the same dialogue level.

C.4.2.9 reproduction_level

The detailed syntax is described on table C.10.

Table C.10: Reproduction_level syntax

Syntax	No. of Bits	Mnemonic
reproduction_level () {		
Surround_reproduction_level	1	bslbf
production_roomtype	2	bslbf
reproduction_level_value	5	uimsbf
}		

C.4.2.9.1 surround_reproduction_level

Table C.11: Surround reproduction level Table

surround_reproduction_level	Description
"0"	The surround channels have the correct level for reproduction
"1"	The surround channels should be attenuated by 3 dB during reproduction

Decoding: It is recommended that the decoder parse this field and pass the value to the reproduction unit to allow correct adjustment of the surround levels.

C.4.2.9.2 production_roomtype

Table C.12: Production room type Table

production_roomtype	Description
"00"	not indicated
"01"	large room
"10"	small room
"11"	reserved

Decoding: It is recommended that the decoder parse this field and pass the value to the reproduction unit to allow correct adjustment of the monitoring equipment.

C.4.2.9.3 reproduction_level_value

Semantics: This field represents the absolute acoustic sound pressure level in dB SPL during the final audio mixing session.

Decoding: The decoder may ignore this field.

C.4.2.10 downmixing_levels_MPEG2

The detailed syntax is described on table C.13. The down mixing levels describe the down mix in the decoder for stereo reproduction.

Table C.13: Downmixing_levels_MPEG2 syntax

Syntax	No. of Bits	Mnemonic
downmixing_levels_MPEG2 () {		
center_mix_level_on	1	bslbf
center_mix_level_value	3	bslbf
Surround_mix_level_on	1	bslbf
Surround_mix_level_value	3	bslbf
}		

C.4.2.10.1 center_mix_level_on

Semantics: If this field is set to "1" the center_mix_value field indicates nominal down mix level of the centre channel with respect to the left and right front channels. *If this field is set to "0" the center_mix_value field shall be set to "000".*

Decoding: It is recommended that the decoder parse this field.

C.4.2.10.2 surround_mix_level_on

Semantics: If this field is set to "1" the surround_mix_value field indicates nominal down mix level of the surround channels with respect to the left and right front channels. *If this field is set to "0" the surround_mix_value field shall be set to "000".*

Decoding: It is recommended that the decoder parse this field.

C.4.2.10.3 mix_level_value

Table C.14: Mix level value Table

mix_level_value	Multiplication factor
"000"	1,000 (0,0 dB)
"001"	0,841 (-1,5 dB)
"010"	0,707 (-3,0 dB)
"011"	0,596 (-4,5 dB)
"100"	0,500 (-6,0 dB)
"101"	0,422 (-7,5 dB)
"110"	0,355 (-9,0 dB)
"111"	0,000 ($-\infty$ dB)

Decoding: The multi-channel decoder may apply these values as gain factors to the individual channels when a down mix for stereo listening has to be created. The values need to be scaled to avoid overload after the mixing process.

C.4.2.11 audio_coding_mode

The detailed syntax is described in table C.15.

Table C.15: Audio coding mode syntax

Syntax	No. of bits	Mnemonic
audio_coding_mode () {		
MPEG2_extension_stream_present	1	bslbf
MPEG2_center	2	bslbf
MPEG2_surround	2	bslbf
MPEG2_lfeon	1	bslbf
MPEG2_copyright_ident_present	1	bslbf
compression_on	1	bslbf
}		

Semantics: The semantics of the fields MPEG2_extension_stream_present, MPEG2_center, MPEG2_surround and MPEG2_lfeon is as defined in the mc_header field in ISO/IEC 13818-3 [3].

If MPEG2_copyright_ident_present is set to "0" the copyright identification in the MPEG-2 mc_header is not filled in. If MPEG2_copyright_ident_present is set to "1" the copyright identification in the MPEG-2 mc_header is used.

Decoding: The decoder may ignore this field. It may be parsed by multiplexers and bitstream monitors to simplify extraction of these parameters from a bitstream.

C.4.2.11.1 compression_on

Semantics: If this field is set to "1" the compression_value field indicates the heavy compression factor used for monophonic down mix reproduction. *If this field is set to "0" the compression_value field shall be "0000 0000".*

Decoding: It is recommended that the decoder parse this field.

C.4.2.12 compression_value

Semantics: This field consists of a value X in the four msb's and a value Y in the four lsb's. The actual value is $48,164 - 6,0206 X - 0,4014 Y$ dB.

Decoding: *These values shall be applied to the sub band samples, before the reconstruction filter when the decoder has to create a mix for monophonic listening where overloading of a subsequent analog transmission is highly undesirable.*

C.4.2.13 coarse_grain_timecode

The detailed syntax is described on table C.16.

Table C.16: Coarse grain time code syntax

Syntax	No. of Bits	Mnemonic
coarse_grain_timecode () {		
coarse_grain_timecode_on	2	bslbf
coarse_grain_timecode_value	14	bslbf
}		

Semantics: If coarse_grain_timecode_on is set to "10" the five msb's of this value represents the time in hours, the next six bits represent time in minutes, and the final three bits represent the time in eight second increments. *If coarse_grain_timecode_on is not set to "10" all the bits of coarse_grain_timecode_value shall be set to "0".*

Decoding: The decoder may ignore this field.

C.4.2.14 fine_grain_timecode

The detailed syntax is described in table C.17.

Table C.17: Fine grain time code syntax

Syntax	No. of Bits	Mnemonic
fine_grain_timecode () {		
fine_grain_timecode_on	2	bslbf
fine_grain_timecode_value	14	bslbf
}		

Semantics: If fine_grain_timecode_on is set to "10" the three msb's of this value represents the time in seconds, the next five bits represent time in video frames, and the final six bits represent the time in fractions of 1/64 of a video frame. *If fine_grain_timecode_on is not set to "10" all the bits of fine_grain_timecode_value shall be set to "0".*

Decoding: The decoder may ignore this field.

C.4.2.15 scale_factor_CRC

Semantics: The scale_factor_CRC permits to verify the integrity of the MPEG Audio scale factors. The coding is according to [19].

Encoding: It recommended that scale_factor_CRC be included for mobile applications.

Decoding: It is recommended to parse the data from the end. The length of the field depends on the bitrate index of the MPEG-1 header of the following frame. It is recommended to always parse the full 32 possible bits.

C.4.2.16 Announcement Switching Data

The transmission of announcement switching data in the ancillary data field of MPEG audio frames is optional. The syntax of the announcement switching data field is described in table C.18. Note that the description in table C.18 is in the reverse order of the transmission. The bit order in each byte is, however, such that the msb comes first in the transmission. The data field length gives the number of bytes following this byte within this data field.

Table C.18: Announcement switching data field

Syntax	No. of Bits	Mnemonic
announcement_switching_data() {		
announcement_switching_data_sync	8	bslbf
data_field_length	8	bslbf
announcement_switching_flag_field_1	16	bslbf
announcement_switching_flag_field_2	16	bslbf
}		

Semantics: The announcement_switching_data_sync should be set to 0 x AD.

The announcement_switching_flag_fields are 16-bit flag fields specifying which type of announcements are actually running. *The association between the bits of the flag field and the announcement types shall be according to the announcement_support_indicator [6]. A bit shall be set to "1" if the announcement is running and it shall be set to "0" if the announcement is not running.*

The announcement_switching_flag_field_1 shall be used for announcements within the audio elementary stream that is actually decoded.

The announcement_switching_flag_field_2 shall be used for announcements within other audio elementary streams. Corresponding links shall be provided by means of the announcement_support_descriptor [6].

Encoding: The `announcement_switching_data_field` is allowed to be embedded at the end of a MPEG audio packet, between the end of the audio data and another data field that is part of the ancillary data field or between two other data fields that are part of the ancillary data field.

If data fields according to DVD-Video, extended ancillary data or ancillary data according to the DAB specification [18] are used, then the `announcement_switching_data_field` is not allowed to be inserted at the end of an audio packet.

Decoding: It is recommended to parse the data from the end.

C.4.2.17 Scale Factor Error Check

The transmission of a scale factor error check in the ancillary data field of MPEG audio frames is optional. The syntax of the corresponding data field is described in table C.19. Note that the description in table C.19 is in the reverse order of the transmission. The bit order in each byte is, however, such that the msb comes first in the transmission. The `data_field_length` gives the number of bytes following this byte within this data field.

Table C.19: Scale factor error check data field

Syntax	No. of Bits	Mnemonic
<code>scale_factor_error_check_data() {</code>		
<code>scale_factor_error_check_data_sync</code>	8	Bslbf
<code>data_field_length</code>	8	Bslbf
scale factor CRC	32	Bslbf
<code>}</code>		

Semantics: The `scale_factor_error_check_data_sync` should be set to 0 x FE.

The `scale_factor` CRC permits to verify the integrity of the MPEG Audio scale factors.

Encoding: The `scale_factor_error_check` is allowed to be embedded at the end of a MPEG audio packet, between the end of the audio packet and another data field that is part of the ancillary data field or between two other data fields that are part of the ancillary data field.

If data fields according to DVD-Video extended ancillary data (as described in clause C.4.1) or ancillary data according to the DAB specification EN 300 401 [18] are used, then the `scale_factor_error_check_data_field` is not allowed to be inserted at the end of an audio packet.

Decoding: It is recommended to parse the data from the end.

C.4.2.18 RDS data via UECP protocol

The transmission of RDS data via the UECP protocol [22] in the ancillary data field of MPEG audio frames is optional. The syntax of the UECP data field is described in table C.20. Note that the description in table C.20 is in the reverse order of the transmission. The bit order in each byte is, however, such that the msb comes first in the transmission. The `data field length` gives the number of bytes following this byte within this data field.

Table C.20: UECP data field

Syntax	No. of Bits	Mnemonic
<code>UECP_data() {</code>		
<code>UECP_data_sync</code>	8	bslbf
<code>data_field_length</code>	8	bslbf
for (<code>i=0; i<N; i++</code>){		
<code>UECP_data_byte</code>	8	uimsbf
}		
<code>}</code>		

Semantics: The UECP_data_sync should be set to 0xFD.

The bytes in the UECP_data_byte field shall be byte aligned with the UECP data bytes. There is no need to align the UECP_data_byte field with the UECP frames. Consequently, one or more complete UECP frames and/or only parts of UECP frames may be contained in one UECP_data_byte field.

The length of the UECP_data_byte field can vary between consecutive audio packets.

Encoding: The encoding complies fully to the UECP specification [22].

The following addresses are assigned to DVB consumer receivers which are tuned to the indicated programme. For dual mono, the Terminal Address allows to assign different RDS information to the different audio channels.

NOTE: Within the DVB system the dual mono mode is generally deprecated. For legacy reasons, however, this option has been kept for RDS transmission.

Table C.21

Site Address	Terminal Address	DVB consumer receiver
0	0	All
1008	0	Stereo
	1	Dual Channel, ch. A
	2	Dual Channel, ch. B
	3	Single Channel (Mono)
	4 to 63	Not yet assigned

For professional decoding equipment at UKW/FM transmitters the addresses are individually assigned.

Decoding: It is recommended to parse the data from the end.

C.5 Detailed specification for MPEG4 AAC, HE AAC and HE AAC v2 Audio

C.5.1 Transmission of MPEG4 Audio ancillary data

*Presence of MPEG-4 ancillary data shall be signalled in DVB SI by setting b_5 in **ancillary_data_identifier** to "1" (see EN 300 468 [6], table 16).*

*MPEG4 ancillary data as defined in this annex shall be placed into a single **data_stream_element()** as defined in ISO/IEC 14496-3, table 4.10 [17].*

*The **data_stream_element()** <DSE> shall follow any combination of related <SCE>, <CPE>, <LFE>, and <FIL <EXT-SBR_DATA>> audio elements, to which the ancillary data applies.*

*The **element_instance_tag** of this **data_stream_element()** shall have the same value as the **element_instance_tag** of the first audio element to which the ancillary data applies.*

Examples of possible streams are:

for a 2-channel program:

```
<CPE><DSE><FIL><TERM><CPE><DSE><FIL><TERM>...
```

for a 2-channel program with SBR:

```
<CPE><SBR(CPE)><DSE><FIL><TERM><CPE><SBR(CPE)><DSE><FIL><TERM>...
```

for a 5.1-channel program

```
<SCE><CPE><CPE><LFE><DSE><FIL><TERM><SCE><CPE><CPE><LFE><DSE><FIL><TERM>...
```

For further reference see clauses 4.5.2.1.2 and 4.5.2.9.2 in ISO/IEC 14496-3 [17].

C.5.2 MPEG4 Audio ancillary data syntax

The syntax of the ancillary data field is described in table C.22. Data are transmitted in the order as given in table C.22.

Table C.22: MPEG4 ancillary data syntax

Syntax	No. of Bits	Mnemonic
MPEG4 ancillary_data() {		
ancillary_data_sync	8	bslfb
bs_info	8	bslbf
ancillary_data_status	8	bslbf
if (downmixing_levels_MPEG4_status == 1)		
downmixing_levels_MPEG4	8	bslbf
if (audio_coding_mode_and_compression_status == 1) {		
audio_coding_mode	8	bslbf
Compression_value	8	bslbf
}		
if (coarse_grain_timecode_status == 1)		
coarse_grain_timecode	16	bslbf
if (fine_grain_timecode_status == 1)		
fine_grain_timecode	16	bslbf
}		

C.5.2.1 ancillary_data_sync

Encoding: *This field shall be set to 0xBC.*

Decoding: The decoder may use this field to verify the availability of the MPEG4 Audio ancillary data.

C.5.2.2 bs_info

The detailed syntax is described in table C.23.

Table C.23: bs_info syntax

Syntax	No. of Bits	Mnemonic
bs_info() {		
mpeg_audio_type	2	bslbf
dolby_surround_mode	2	bslbf
drc_presentation_mode	2	bslbf
reserved, set to "00"	2	bslbf
}		

C.5.2.2.1 mpeg_audio_type

Table C.24: MPEG audio type Table

mpeg_audio_type	Description
"00"	Reserved
"01"	Reserved
"10"	Reserved
"11"	MPEG4 Audio data

Encoding: *This field shall be set according to table C.24.*

Decoding: The decoder may ignore this field.

C.5.2.2.2 dolby_surround_mode

Table C.25: Dolby surround mode Table

dolby_surround_mode	Description
"00"	Dolby surround mode not indicated
"01"	2-ch audio part is not Dolby surround encoded
"10"	2-ch audio part is Dolby surround encoded
"11"	Reserved

Semantics: In case of 2-channel audio streams it can be indicated, whether the audio signal is encoded in Dolby surround mode.

Encoding: This field may be provided by encoders when the audio stream is in 2-channel (stereo) format. *It shall be set to "00" for other than 2-channel audio streams.*

Decoding: It is strongly recommended that the decoder parses this field and provides this information to the reproduction set-up.

C.5.2.2.3 drc_presentation_mode

Table C.26: DRC presentation mode Table

drc_presentation_mode	Description
"00"	DRC presentation mode not indicated
"01"	DRC presentation mode 1
"10"	DRC presentation mode 2
"11"	Reserved

Semantics: This field indicates whether ISO/IEC 14496-3 [17] or C.5.2.5 dynamic range control shall take priority on the outputs as defined in clause C.5.3.

To avoid disturbances in the audio output, it should not be changed within an elementary stream.

Encoding: This field may be provided by encoders. *It shall be set to "00" if the DRC presentation mode is not indicated.*

Decoding: It is strongly recommended that the decoder parses this field and makes use of this information.

C.5.2.3 ancillary_data_status

The detailed syntax is described on table C.27.

Table C.27: Ancillary_data_status syntax

Syntax	No. of Bits	Mnemonic
ancillary_data_status() {		
Reserved, set to "0"	1	bslbf
Reserved, set to "0"	1	bslbf
Reserved, set to "0"	1	bslbf
downmixing_levels_MPEG4_status	1	bslbf
Reserved, set to "0"	1	bslbf
audio_coding_mode_and_compression_status	1	bslbf
coarse_grain_timecode_status	1	bslbf
fine_grain_timecode_status	1	bslbf
}		

Semantics: The bits in this field indicate the presence of the associated fields in the ancillary data.

Encoding: *A bit in this field shall be set to "1" if the associated field is present in the bitstream.*

Decoding: It is strongly recommended that the decoder parse this field to allow parsing of the following fields in the ancillary data section.

C.5.2.4 downmixing_levels_MPEG4

When multichannel audio streams are decoded by an IRD and only 2-channel audio output is required, then matrix mix down shall be applied.

This part of the MPEG-4 ancillary data gives the possibility to transmit matrix mix down coefficients with higher resolution than defined in ISO/IEC 14496-3 [17]. The detailed syntax is described in table C.28.

Table C.28: Downmixing_levels_MPEG4 syntax

Syntax	No. of Bits	Mnemonic
downmixing_levels_MPEG4 () {		
center_mix_level_on	1	bslbf
center_mix_level_value	3	bslbf
surround_mix_level_on	1	bslbf
surround_mix_level_value	3	bslbf
}		

Encoding: It is strongly recommended that this matrix mix down information is supplied by the encoder and both, **center_mix_level_on** and **surround_mix_level_on** are set to "1" when multichannel audio is transmitted.

Decoding: It is strongly recommended that the decoder parses this field and uses the information in cases where matrix mix down is needed.

C.5.2.4.1 center_mix_level_on

Semantics: This field indicates, whether the **center_mix_value** field carries information for matrix mix down.

Encoding: *If this field is set to "1" the **center_mix_value** field shall indicate the matrix mix down level of the centre channel with respect to the left and right front channels. If this field is set to "0" the **center_mix_value** field shall be set to "000".*

Decoding: It is strongly recommended that the decoder parses and makes use of this field.

C.5.2.4.2 surround_mix_level_on

- Semantics: This field indicates, whether the **surround_mix_value** field carries information for matrix mix down.
- Encoding: *If this field is set to "1" the surround_mix_value shall indicate the matrix mix down level of the surround channels with respect to the left and right front channels. If this field is set to "0" the surround_mix_value field shall be set to "000".*
- Decoding: It is strongly recommended that the decoder parses and makes use of this field.

C.5.2.4.3 mix_level_value

Table C.29: Mix level value Table

mix_level_value	Multiplication factor
"000"	1,000 (0,0 dB)
"001"	0,841 (-1,5 dB)
"010"	0,707 (-3,0 dB)
"011"	0,596 (-4,5 dB)
"100"	0,500 (-6,0 dB)
"101"	0,422 (-7,5 dB)
"110"	0,355 (-9,0 dB)
"111"	0,000 ($-\infty$ dB)

- Encoding: *When provided, the values of center_mix_level_value and surround_mix_level_value shall be set to indicate the multiplication factors for 2-channel matrix mix down. The broadcaster shall ensure that sufficient headroom and/or dynamic range control values are included in the transmission to prevent any overload when downmixing. For further details refer to clause C.5.3.*
- Decoding: The multi-channel decoder may apply these values as gain factors to the individual channels when a down mix for 2-channel stereo listening has to be created. The derived stereo signal can be generated within a matrix-mixdown decoder by use of the following equations:

$$L_o = L \text{ + } \text{center_mix_level} \text{ x } C \text{ + } \text{surround_mix_level} \text{ x } L_s$$

$$R_o = R \text{ + } \text{center_mix_level} \text{ x } C \text{ + } \text{surround_mix_level} \text{ x } R_s$$

where L, R, C, L_s and R_s are the transmitted source signals and L_o and R_o are the derived 2-channel stereo signals.

When a down-mix for 1-channel monophonic listening has to be created, a matrix mixdown decoder can make use of the following equation:

$$M = L \text{ + } R \text{ + } 2 \text{ x } \text{center_mix_level} \text{ x } C \text{ + } \text{surround_mix_level} \text{ x } (L_s \text{ + } R_s)$$

where L, R, C, L_s and R_s are the transmitted source signals and M is the derived mono signal.

To prevent any highly undesired overload, dynamic range control values shall be applied (see clause C.5.3).

C.5.2.5 audio_coding_mode

The detailed syntax is described in table C.30.

Table C.30: Audio coding mode syntax

Syntax	No. of Bits	Mnemonic
audio_coding_mode () {		
reserved, set to "000 0000"	7	bslbf
compression_on	1	bslbf
}		

Decoding: It is recommended that the decoder parse this field.

C.5.2.5.1 compression_on

Semantics: This field indicates, whether the **compression_value** field carries information.

Encoding: If this field is set to "1" the **compression_value** field indicates the heavy compression factor. *If this field is set to "0" the **compression_value** field shall be "0000 0000".*

Decoding: It is strongly recommended that the decoder parses and makes use of this field.

C.5.2.5.2 compression_value

Semantics: This field consists of a value X in the four msb's and a value Y in the four lsb's. The actual compression value is $48,164 - 6,0206 X - 0,4014 Y$ dB.

The **compression_value** field indicates a heavy compression factor which may be applied instead of ISO/IEC 14496-3 [17] **dynamic_range_info()** on the decoder side when a strong dynamic range compression is desired.

Encoding: The encoder may provide this information.

If provided, besides possible artistic reduction of dynamic range, these values shall be suitable to prevent clipping for monophonic and stereophonic downmix and multichannel ployout according to clause C.5.3.

Decoding: *If **compression_on** is set to "1", the IRD shall apply these values instead of the ISO/IEC 14496-3 [17] **dynamic_range_info()** when creating a monophonic RF modulated output or as required according to clause C.5.3.*

C.5.2.6 coarse_grain_timecode

See clause C.4.2.13.

C.5.2.7 fine_grain_timecode

See clause C.4.2.14.

C.5.2.8 Persistence of MPEG4 ancillary data

Though it may be appropriate to send the MPEG4 ancillary data periodically, it may not be required to send it with each audio frame.

Each value remains unchanged and in effect unless it is specifically overwritten by new transmitted data structures.

After synchronizing to a new stream, an IRD should assume the following values as default:

Table C.31: Default values after synchronization

Data field	Default value
dolby_surround_mode	"00"
drc_presentation_mode	"00"
center_mix_level_value	"010"
surround_mix_level_value	"010"
compression_on	"0"
compression_value	"0000 0000"
coarse_grain_timecode	"00 0000000000000000"
fine_grain_timecode	"00 0000000000000000"

*NOTE: It may be desirable that any encoder sends MPEG4 ancillary data at least at each Random Access Point of the bitstream to start decoding with well-defined MPEG4 ancillary data. (PES packets which contain the **StreamMuxConfig()** at the beginning of an **AudioSyncFrame()** are Random Access Points of MPEG-4 Audio formatted according to clause 6.4.).*

C.5.3 Announcement Switching Data

The transmission of announcement switching data in MPEG4 ancillary data is optional. The syntax of the announcement switching data field is described in table C.32.

Table C.32: Announcement switching data field

Syntax	No. of Bits	Mnemonic
announcement_switching_data() {		
announcement_switching_data_sync	8	bslbf
data_field_length	8	bslbf
announcement_switching_flag_field_1	16	bslbf
announcement_switching_flag_field_2	16	bslbf
}		

Semantics: The **announcement_switching_data_sync** should be set to 0xAD.
The **data_field_length** gives the number of bytes following this byte within this data field.

The **announcement_switching_flag_fields** are 16-bit flag fields specifying which type of announcements are actually running. *The association between the bits of the flag field and the announcement types shall be according to the **announcement_support_indicator** [6]. A bit shall be set to "1" if the announcement is running and it shall be set to "0" if the announcement is not running.*

*The **announcement_switching_flag_field_1** shall be used for announcements within the audio elementary stream that is actually decoded.*

*The **announcement_switching_flag_field_2** shall be used for announcements within other audio elementary streams. Corresponding links shall be provided by means of the **announcement_support_descriptor** [6].*

Decoding: It is recommended that the decoder parse this field.

C.5.4 DRC Presentation Mode

Dynamic Range Control may either be used to limit the dynamic range of an audio signal to improve intelligibility under noisy listening environments or may be used to prevent highly undesired overloads. The latter may occur when audio is played back at a higher target level than its program reference level or when a reduction of the number of output channels has to be performed (i.e. downmixing).

To avoid these overloads, special constraints while producing audio signals should be maintained or appropriate dynamic range control values should be transmitted along with the audio as metadata. Besides the ISO/IEC 14496-3 [17] **dynamic_range_info()** also the **compression_value** of this specification (see clause C.5.2.5.2) can be used for this purpose.

Notes on ISO/IEC 14496-3 [17] **dynamic_range_info()**:

These values carry the "light compression" gains. According to ISO/IEC 14496-3 [17], these values may be scaled by factors between 0 and 1 prior to appliance to match individual circumstances. In ISO/IEC 14496-3 [17], scaling is differentiated for negative and positive gains. While scaling of positive gains (less increase of loudness) is always possible, scaling of negative gains (less attenuation) must be prohibited under special circumstances in order to accomplish overload prevention.

Notes on **compression_value**:

This values carries the "heavy compression" gain. It is used when appliance of light compression according to ISO/IEC 14496-3 [17] **dynamic_range_info()** is not sufficient. No scaling is allowed for this value.

Encoding: The broadcaster will mix programmes for DRC presentation mode 1 or DRC presentation mode 2 receivers. The use of these modes should be signalled by the encoder via the **drc_presentation_mode** field (see clause C.5.2.2.3). *If the DRC presentation mode is not indicated, the **drc_presentation_mode** field shall be set to "00".*

DRC Presentation Mode 1:

If 'DRC presentation mode 1' is signalled in the **drc_presentation_mode** field, the following applies:

Both dynamic range control data according to ISO/IEC 14496-3 [17] and to C.5.2.5 shall be transmitted.

To avoid any highly undesired overload for levelling and/or downmixing towards a target level of -23 dB (corresponding a value of 92), the broadcaster shall ensure that sufficient headroom and/or dynamic range control data according to clause C.5.2.5 are included in the transmission.

To avoid any highly undesired overload for levelling and/or downmixing towards a target level of -31 dB (corresponding a value of 124), the broadcaster shall ensure that sufficient headroom and/or dynamic range control data according to ISO/IEC 14496-3 [17] are included in the transmission.

DRC Presentation Mode 2:

If 'DRC presentation mode 2' is signalled in the **drc_presentation_mode** field, the following applies:

To avoid any highly undesired overload when levelling and/or providing a stereophonic downmix towards a target level of -23 dB (corresponding a value of 92), the broadcaster shall ensure that sufficient headroom and/or dynamic range control data according to ISO/IEC 14496-3 [17] are included in the transmission.

To avoid any highly undesired overload when levelling and providing a monophonic downmix (e.g. RF modulated output) towards a target level of -23 dB (corresponding a value of 92), the broadcaster should ensure that sufficient headroom and/or dynamic range control data according to clause C.5.2.5 are included in the transmission.

Decoding: According to clause 6.4.3, it is strongly recommended that the IRD operates at one of two different target levels.

If the IRD supports the DRC presentation mode, the following rules shall apply:

Operation at target level -31 dB:

If the IRD operates at a target level of -31 dB, dynamic range control data according to ISO/IEC 14496-3 [17] shall be applied if present.

If a downmix of multichannel audio is performed, scaling of negative gain words (ctrl1 as of chapter 4.5.2.7.2 of ISO/IEC 14496-3 [17]) is not permitted. Otherwise, scaling of DRC gain words is allowed.

Operation at target level -23 dB:

If the IRD operates at a target level of -23 dB and DRC presentation mode 1 is signalled, dynamic range control data according to clause C.5.2.5 shall be applied if present. Scaling of DRC gain words is not allowed in this case.

If the IRD operates at a target level of -23 dB and DRC presentation mode 2 is signalled, dynamic range control data according to ISO/IEC 14496-3 [17] shall be applied if present on stereophonic and multi-channel outputs. Scaling of negative gain words (ctrl1 as of chapter 4.5.2.7.2 of ISO/IEC 14496-3 [17]) is not permitted (regardless of whether a downmix of multichannel audio is performed or not).

When presentation mode 2 is signalled, dynamic range control data according to clause C.5.2.5 shall not be applied to stereophonic and multi-channel outputs.

When downmixing for monophonic outputs, dynamic range control data according to clause C.5.2.5 shall be applied if present, otherwise dynamic range control data according to ISO/IEC 14496-3 [17] shall be applied if present. Scaling of DRC gain words is not allowed in this case.

Table C.33 illustrates these two different DRC presentation modes:

Table C.33: Required Dynamic Range Control schemes for playback to prevent overload when DRC Presentation Modes is signalled

	Channels of playback system	Playback corresponding to a target level of -31 dB		Playback corresponding to a target level of -23 dB		
		5.1	2.0	5.1	2.0	1.0
DRC presentation mode 1	2-channel Stereo Audio content	<i>Not specified</i>	ISO DRC (scaling allowed) or Compression_value	<i>Not specified</i>	Compression_value	Compression_value
	Multichannel Audio content	ISO DRC (scaling allowed) or Compression_value	ISO DRC (scaling restricted) or Compression_value	Compression_value	Compression_value	Compression_value
DRC presentation mode 2	2-channel Stereo Audio content	<i>Not specified</i>	ISO DRC (scaling allowed)	<i>Not specified</i>	ISO DRC (scaling restricted)	Compression_value
	Multichannel Audio content	ISO DRC (scaling allowed)	ISO DRC (scaling restricted)	ISO DRC (scaling restricted)	ISO DRC (scaling restricted)	Compression_value
<p>NOTE 1: ISO DRC (scaling allowed): Dynamic range control data according to ISO/IEC 14496-3 [1717] shall be applied. Scaling of both positive and negative gain words (ctrl1 and ctrl2 as of chapter 4.5.2.7.2 of ISO/IEC 14496-3 [17]) is allowed.</p> <p>NOTE 2: ISO DRC (scaling restricted): Dynamic range control data according to ISO/IEC 14496-3 [17] shall be applied. Scaling of negative gain words (ctrl1 as of chapter 4.5.2.7.2 of ISO/IEC 14496-3 [17]) is not permitted (i.e. ctrl1 has to be equal to 1). Scaling of positive gain words is still possible.</p> <p>NOTE 3: Compression_value: If dynamic range control data according to clause C.5.2.5 are present, these values shall be applied without any scaling. Appliance of dynamic range control data according to ISO/IEC 14496-3 [17] is only permitted if dynamic range control data according to clause C.5.2.5 are not present.</p>						

Annex D (normative): Coding of Data Fields in the Private Data Bytes of the Adaptation Field

D.1 Introduction

A compliant bitstream may contain data fields in the private data bytes of the adaptation field [1] for use in certain applications. *When such private data bytes are used in the manner described in clause D.2 of this annex or they are used in combination with PVR-assisting coding as described in clause D.3 (below) the bitstream shall conform to the provisions of this annex.* This annex does not apply to SVC bitstreams. In the case of an MVC transmission, this annex currently applies only to the base layer.

This annex contains the guidelines required to include and to decode data fields in the private data bytes of the adaptation field [1] for PVR and other applications.

D.2 Private data bytes detailed specification

Transport stream (TS) packets coded according to ITU-T Recommendation H.222.0 / ISO/IEC 13818-1 [1] may include an adaptation field. The presence of an adaptation field is indicated by means of the `adaptation_field_control`, i.e. a 2-bit field in the header of the TS packet. The adaptation field itself may contain `private_data_bytes`. The presence of private data bytes is signalled by means of the `transport_private_data_flag` coded at the beginning of the adaptation field. If private data bytes exist the total number of private data bytes is specified by means of the `transport_private_data_length`, an 8-bit field that is directly followed by the private data bytes. The private data bytes may be composed of one or more data fields as shown in figure D.1. Gaps are not allowed between two data fields.

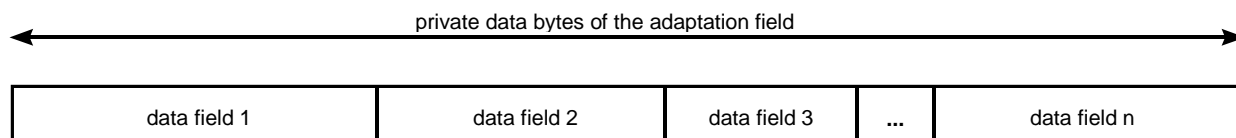

Figure D.1: Coding scheme for private data bytes within the adaptation field

Encoding: *The support of data fields that are specified in this annex shall be indicated by means of the `adaptation_field_data_descriptor` [6]. This descriptor shall be inserted in the corresponding `ES_info` loop.*

The following semantics apply to all data fields specified in this annex.

`data_field_tag`: The data field tag is an 8-bit field which identifies the type of each data field. The values of `data_field_tag` are defined in table D.1.

`data_field_length`: The data field length is an 8-bit field specifying the total number of bytes of the data portion of the data field following the byte defining the value of this field.

Table D.1: Allocation of `data_field_tags`

<code>data_field_tag</code>	Description
0x00	Reserved
0x01	Announcement switching data field
0x02	AU_information data field
0x03	PVR_assist_information data field
0x04 to 0x9F	Reserved for future use
0xA0 to 0xFF	User defined

The presence of data field tag values 0x01, 0x02 and 0x03 shall be indicated via bits b_0 , b_1 and b_2 respectively of the `adaptation_field_data_identifier` in the adaptation field data descriptor (see clause 6.2.1 of EN 300 468 [6]).

Decoding: The IRD design should be made under the assumption that any structure or combination of structures as permitted by this annex may occur in the broadcast stream. The IRD is not required to make use of this data.

D.2.1 Announcement Switching Data

The announcement switching data field is used to indicate whether spoken announcements are actually running or not. In comparison with that, the general support of announcements is indicated by means of the `announcement_support_descriptor` [6].

The transmission of the announcement switching data field is optional but it shall be continuously provided in those audio streams that may carry announcements at some point in time. The announcement switching data field shall be present at least every 100 ms. The syntax of the announcement switching data field is described in table D.2.

Table D.2: Announcement switching data field

Syntax	No. of Bits	Mnemonic
<code>announcement_switching_data() {</code>		
<code>data_field_tag</code>	8	uimsbf
<code>data_field_length</code>	8	uimsbf
<code>announcement_switching_flag_field</code>	16	bslbf
<code>}</code>		

Semantics: `announcement_switching_flag_field`: This 16-bit flag field specifies which type of announcements are actually running. The association between the bits of the flag field and the announcement types shall be according to the `announcement_support_indicator` that is specified for the `announcement_support_descriptor` [6]. A bit shall be set to "1" if the announcement is running and it shall be set to "0" if the announcement is not running.

D.2.2 AU_information

The `AU_information` data field is used to signal the presence of the start of an access unit in the payload of the transport packet containing the data field, and to convey information about that access unit that is of use to PVR applications. All the information provided in this adaptation data field should be considered "helper" information rather than definitive information. Thus, if there are any conflicts between the information signalled in this adaptation data field and the actual stream, then the information in the stream shall take precedence over the information in this adaptation data field. However, such a conflict should be considered an error condition and as such should not occur. It is recommended that the `AU_information` data field is present at the start of each access unit of an H.264/AVC [16] video streams.

Where multiple access units occur in a transport packet, then multiple `AU_information` data fields may be used. Each adaptation data field shall apply to the corresponding access unit in the transport packet. I.e. the first data field shall apply to the first access unit starting in the transport packet, the second data field shall apply to the second access unit starting in the transport packet, etc.

The `AU_information` data field(s), when present, shall be the first data field(s) in the adaptation field.

There shall not be more adaptation data fields with the same data field tag value than there are access units starting in the packet.

Table D.3: AU_information data field

Syntax	No. of Bits	Mnemonic
AU_information () {		
data_field_tag	8	Uimsbf
data_field_length	8	Uimsbf
AU_coding_format	4	Uimsbf
AU_coding_type_information	4	Bslbf
AU_ref_pic_idc	2	Uimsbf
AU_pic_struct	2	Bslbf
AU_PTS_present_flag	1	Bslbf
AU_profile_info_present_flag	1	bslbf
AU_stream_info_present_flag	1	bslbf
AU_trick_mode_info_present_flag	1	bslbf
if (AU_PTS_present_flag == "1") {		
AU_PTS_32	32	uimsbf
}		
if (AU_stream_info_present_flag == "1") {		
Reserved	4	"0000"
AU_frame_rate_code	4	uismbf
}		
if (AU_profile_info_present_flag == "1") {		
AU_profile	8	uismbf
AU_constraint_set0_flag	1	bslbf
AU_constraint_set1_flag	1	bslbf
AU_constraint_set2_flag	1	bslbf
AU_AVC_compatible_flags	5	bslbf
AU_level	8	uismbf
}		
if (AU_trick_mode_info_present_flag == "1") {		
AU_max_I_picture_size	12	uismbf
AU_nominal_I_period	8	uismbf
AU_max_I_period	8	uismbf
Reserved	4	"0000"
}		
if (data_parsed < data_field_length) {		
AU_Pulldown_info_present_flag	1	bslbf
AU_reserved_zero	6	'000000'
AU_flags_extension_1	1	bslbf
if (AU_Pulldown_info_present_flag == '1') {		
AU_reserved_zero	4	'0000'
AU_Pulldown_info	4	bslbf
}		
if (AU_flags_extension_1 == '1') {		
AU_reserved	8	bslbf
}		
}		
for(i=0; i<n; i++) {		
AU_reserved_byte	8	bslbf
}		
}		

Semantics:

data_field_tag: This shall have the value 0x02.

data_field_length: This indicates the length of the *adaptation data field*. The values 0 and 1 may be used to signal short versions of the *adaptation data field*. The value 0 means that no fields after the data_field_length are sent, and is used as a dummy *adaptation data field*. The value 1 means that only the fields AU_coding_format and AU_coding_type_information are present.

AU_coding_format: This shall signal the coding format used by the elementary stream carried on this packet. The values are as shown in table D.4.

Table D.4: AU_coding_format values

Value	Stream Type
0	Undefined
1	ITU-T Recommendation H.262 / ISO/IEC 13818-2 [2] Video or ISO/IEC 11172-1 [8] constrained parameter video stream
2	H.264/AVC video stream as defined in ITU-T Recommendation H.264 / ISO/IEC 14496-10 [16] Video
3	VC-1 video stream as defined in SMPTE ST 421 [20]
4-0xF	Reserved

AU_coding_type_information: Indicates the coded picture/slice types present in the immediately following access unit. For ITU-T Recommendation H.264 / ISO/IEC 14496-10 [16] video, this field shall be interpreted as a four bit field with the syntax shown in table D.5.

Table D.5: AU_coding_type_information for ITU-T Recommendation H.264 / ISO/IEC 14496-10 video

Syntax	No. of Bits	Mnemonic
AU_IDR_slice_present_flag	1	bslbf
AU_I_slice_present_flag	1	bslbf
AU_P_slice_present_flag	1	bslbf
AU_B_slice_present_flag	1	bslbf

For ITU-T Recommendation H.262 / ISO/IEC 13818-2 [2] Video, this field shall be interpreted according to table D.6. These values are identical to (but one bit longer than) the values in table 6-12 of ISO/IEC 13818-2 [2].

For VC-1 (SMPTE ST 421 [20]), this field shall be interpreted as per table D.6.

Table D.6: AU_coding_type_information for ITU-T Recommendation H.262 / ISO/IEC 13818-2 video

Value	AU_coding_type_information
0	Undefined
1	I
2	P
3	B
4 to 0xF	Reserved

AU_ref_pic_idc: This field indicates if any of the access unit is required in the reconstruction of other access units. The value "00" means that it is not used by other access units. In the case of ITU-T Recommendation H.264 / ISO/IEC 14496-10 [16], the value shall be the nal_ref_idc field in the NAL header used for any slice that makes up the access unit.

For VC-1 (SMPTE ST 421) [20], this shall take the value "00" for all pictures (and related headers) that are not used as reference, and shall not take the value "00" for all pictures that are used as reference.

For ITU-T Recommendation H.262 / ISO/IEC 13818-2 [2], this field shall take the value "00" for pictures (and related headers) that are not used as reference (i.e. B pictures), and shall not take the value "00" for all other pictures (and related headers).

AU_pic_struct: This field shall be set to "01" if the access unit is a top field picture, "10" if it is a bottom field. Otherwise, it shall be set to "00". "11" value is reserved.

AU_PTS_present_flag: This field shall be set to "1" when the AU_PTS_32 value is present in the descriptor, otherwise it shall take the value "0".

AU_profile_info_present_flag: This field shall be set to "1" when the AU_profile_idc and AU_level_idc values are present in the descriptor, otherwise it shall take the value "0".

AU_stream_info_present_flag: This field shall be set to "1" when the AU_frame_rate_code value is present in the descriptor, otherwise it shall take the value "0".

AU_trick_mode_info_present_flag: *This field shall be set to "1" when the AU_max_I_picture_size and AU_max_I_period are present in the descriptor.*

AU_PTS_32: The 32 most significant bits of the 33-bit PTS encoded in the PES header immediately following this adaptation field, or of the value that applies to the access unit to which this descriptor applies, if no PES header is present.

AU_frame_rate_code: This field indicates the video frame rate in the stream carried on the current PID. In the case of video, this is encoded as in clause 6.3.3 of ISO/IEC 13818-2 [2]:2000, as shown in table 6-4 of the same. The values in this table are informatively replicated on table D.7.

Table D.7: Informative Frame Rate values taken from table 6-4 of 13818-2:2000

AU_frame_rate_code	Corresponding Frame Rate (Hz)
0	Forbidden
1	23,976
2	24
3	25
4	29,97
5	30
6	50
7	59,94
8	60
9 to 0xF	Reserved

AU_profile: This field conveys the profile used to which the access unit conforms.

For ITU-T Recommendation H.264 / ISO/IEC 14496-10 [16] video this contains the profile_idc value as defined ISO/IEC 14496-10 [16], annex A.

For ITU-T Recommendation H.262 / ISO/IEC 13818-2 [2] video the least significant 3 bits of this field carry the profile as defined in clause 8 of ITU-T Recommendation H.262 / ISO/IEC 13818-2 [2].

For VC-1 (SMPTE ST 421) [20] video the least significant bits of this field carry the profile as defined in SMPTE ST 421 [20].

Constraint_set0_flag, constraint_set1_flag, constraints_set2_flag, AVC_compatible_flags: These fields carry the same semantics as the fields of the same name in the AVC_video_descriptor in clause 2.6.64 of ISO/IEC 13818-1: [1], which in turn have semantics defined in ISO/IEC 14496-10 [16], clause 7.4.2.1. Note that with High profile, the first bit in AVC_compatible_flags contains constraint_set3_flag.

For ITU-T Recommendation H.262 / ISO/IEC 13818-2 [2] video and VC-1 (SMPTE ST 421) [20] video these fields shall take the value "0".

AU_level: This field conveys the level used to which the access unit conforms.

For ITU-T Recommendation H.264 / ISO/IEC 14496-10 [16] video this carries the level_idc value as defined in ISO/IEC 14496-10 [16], annex A.

For ITU-T Recommendation H.262 / ISO/IEC 13818-2 [2] video the least significant 4 bits of this field carry the level as defined in clause 8 of ITU-T Recommendation H.262 / ISO/IEC 13818-2 [2].

For VC-1 (SMPTE ST 421) video, the least significant bits of this field shall carry the level as defined in SMPTE ST 421 [20].

AU_max_I_picture_size: This value indicates the buffer size, in units of 16 x 1 024 bits, that is implemented by the encoder rate control, and thus the maximum intra picture size that can be found in the current bitstream. *This value, according to profile and level, shall comply with ISO/IEC 14496-10 [16] and ISO/IEC 13818-2 [2] limits.* The value 0 is forbidden.

AU_nominal_I_period: This value indicates the nominal distance between two consecutive I/IDR pictures, on a frame picture count basis. The value 0 is forbidden.

AU_max_I_period: This value indicates the maximum distance that can be found in the stream between two consecutive I/IDR pictures, on a frame picture count basis. The value 0 is forbidden.

AU_Pulldown_info_present_flag: This field shall be set to '1' if the AU_Pulldown_info field is present.

AU_flags_extension_1: This field shall be set to '1' if the AU_reserved bytes is used for additional flags.

NOTE 1: This flag provides for future extensions. Whilst for the current specification, the value of this flag should be '0', the value of '1' should be correctly processed.

AU_Pulldown_info: This field carries the four bits carried in the H.264/AVC structure signalling the AU's display characteristics, specifically the pic_struct field of the picture timing SEI message. *The default value for this field shall be the same as AU_pic_struct.* Table D.8 shows the default values to be used for Pulldown_info if the field is not transmitted.

Table D.8: AU_Pulldown_info default values

AU_pic_struct default	AU_Pulldown_info value
00	0
01	1
10	2

NOTE 2: The combination of "AU_pic_struct" and "AU_Pulldown_info" may only be correct when "AU_pic_struct" is set to "00" and "AU_Pulldown_info" is present and set equal to the "pic_struct" field of the picture timing SEI message for H.264/AVC. For VC-1 (SMPTE ST 421) and MPEG-2 ISO/IEC 13818-2 / ITU-T Recommendation H.262 [2], it is recommended that these syntax elements are set to 0.

D.3 PVR assistance

D.3.1 Introduction (informative)

The "PVR_assist_information" data field is used to signal information with the aim of helping PVR applications perform trick-play operations but does not mandate any specific PVR device behaviour. The information in this clause is specific to H.264/AVC and could be extended for use with other video codecs.

The "PVR_assist_information" data field may be used in addition to the "AU_information" data field, but it is recommended that it be used independently. It is recommended that the PVR assist information is present at the start of each video access unit.

PVR assist information is conveyed in 3 levels. The first level imposes minor encoding constraints in addition to what is specified in clauses 5.5, 5.6 and 5.7 of the present document. See clause D.3.2 for these additional constraints. An application conveying just the first level of information sets the "data_field_length" value to "0" in the PVR assist information data and this may be conveyed at each picture or at a RAP. The second level of information includes the first level (encoding constraints) and adds signalling of picture interdependencies using the syntax element "PVR_assist_tier_pic_num". Coding of this syntax element is specified in clause D.3.3. An application conveying just the first and second levels of PVR assist information sets the syntax element "data_field_length" value to "0x01", includes a correct value for "PVR_assist_tier_pic_num" (tier number), conveys the "PVR_assist_tier_pic_num" syntax element for each picture and sets all the following syntax elements to "0":

- pvr_assist_block_trick_mode_present_flag.
- pvr_assist_pic_struct_present_flag.
- pvr_assist_tier_next_pic_in_tier_present_flag.
- pvr_assist_substream_info_present_flag.
- pvr_assist_extension_present_flag.

Based on the "PVR_assist_tier_pic_num" syntax element, the third level provides additional information aimed at assisting PVR applications with the ability to perform trick-play operations. The additional information includes the following two methods as specified in clauses D.3.3 and D.3.4:

- 1) Information related to a Tier framework which describes signalling for extractable and decodable sub-sequences based on pictures interdependencies. This allows the PVR application to efficiently select pictures when performing a given trick-mode.
- 2) Information related to a sub-stream framework which explicitly signals the achievable trick-play speeds and their associated subset of pictures.

Depending on the application, it is possible to use none, one or a combination of the two frameworks. When the PVR assist information includes signalling for both the frameworks, receivers are only expected to use either one of the signalled information.

In addition, the PVR assist information provides segmentation information and signalling to selectively block respective trick modes.

D.3.2 Encoding of PVR assist information (normative)

This clause describes and specifies a set of encoding guidelines that shall be used when PVR assist information is conveyed in the MPEG-2 transport stream.

In addition to the constraint of one video access unit (AU) start per PES packet, each PES packet shall contain exactly one AU. The first payload byte after the PES header shall be the start of the AU. The "data_alignment_indicator" in the PES header shall be set to a value of "1".

If there are any conflicts between the information signalled in this PVR assist information and the actual stream, then the information in the stream shall take precedence over the information in this PVR assist information. However, such a conflict should be considered an error condition and as such should not occur.

When PVR assist information is present, it shall be located in the adaptation header's private data field of MPEG-2 transport stream packets containing the PES header of video access units. These MPEG-2 transport packets shall have their "payload_unit_start_indicator" (PUSI) flag set to a value of "1" and the adaptation control field set to a value of "11".

The PVR assist information uses a tag, length, value (TLV) structure, consistent with the usage shown in clause D.2, with a "data_field_tag" value of "0x03". *Note that when the "AU_information" with a "data_field_tag" value of "0x02" is present in the same adaptation field, it shall precede the PVR assist information.* In this instance, there should be no conflicts between the information provided in both data fields. *Any conflict shall be considered an error condition and the PVR assist information shall take priority.*

The maximum time interval between successive RAP pictures shall be less than or equal to 1,28 seconds. This value accommodates variations either due to non-integer frame rates or GOP lengths that are a power of 2 up to 64 pictures. While the 1,28 seconds value is derived for a GOP of 64 pictures for 50 Hz systems, the corresponding value is 1,068 seconds for 60 Hz systems. It is strongly recommended that the maximum time interval be less than or equal to 1,068 seconds for 60 Hz systems.

Non-paired fields shall not be used in H.264/AVC Bitstreams.

D.3.3 Tier framework

The method is based on a tier system framework that conceptually parallels the data dependency hierarchy system described in clause D.2.11 of ITU-T Recommendation H.264 / ISO/IEC 14496-10 [16] to achieve independently decodable sub-sequences that can be extracted and used by PVR applications to fulfil trick modes.

The premise for the tier framework is to signal picture interdependencies to assist PVR applications in fulfilling trick modes. The method is flexible and adapts to the potentially elaborate picture interdependencies that may be present in an H.264/AVC stream. The tier framework extends its flexibility and adaptability without imposing encoding constraints.

D.3.3.1 Background (informative)

A hierarchy of data dependency tiers contains at most 7 tiers. The tiers are ordered hierarchically from "1" to "7" based on their "decodability" so that any picture with a particular tier number does not depend directly or indirectly on any picture with a higher tier number.

D.3.3.2 Specification (normative)

Each picture in the video stream may belong to one of the 7 tiers. For any value of $k = 1, \dots, 5$, any picture in the k^{th} tier shall not depend directly or indirectly on the processing or decoding of any picture in the $(k+1)^{\text{th}}$ tier or above.

This implies the following:

- A picture that depends on a reference picture cannot have a tier number smaller than the tier number of the reference picture.
- A picture that depends on a picture issuing an MMCO that affects its picture referencing cannot have a tier number smaller than the tier number of the picture issuing the MMCO.

Two field pictures belonging to the same frame shall have the same tier number. Starting at a RAP, the two field pictures belonging to the same frame may be found by checking the value of "PVR_assist_pic_struct", if present, in consecutive pictures.

Tier 1 consists of the first level of picture extractability, and each subsequent tier corresponds to the next level of picture extractability in the video stream. *All RAP pictures shall belong to Tier 1 and all Tier 1 pictures shall be RAP pictures.* Tier 5 is the largest tier number that may be assigned to reference pictures that are intended to be extracted for trick modes. Tiers 6 and 7 correspond to the last level of picture extractability such as discardable pictures and pictures that are not used as reference for trick-modes. Tiers 6 and 7 pictures are intended to be discardable for trick-mode purposes and do not depend on other Tier 6 and 7 pictures. *For H.264/AVC video, all pictures belonging to Tier 7 shall have "nal_ref_idc" equal to "0".* It should be noted, that some pictures with "nal_ref_idc" equal to "0" may either be signalled as Tier 6 or Tier 7 and some discardable pictures with "nal_ref_idc" not equal to "0" may be signalled as Tier 6.

Starting from a RAP picture and including the RAP picture, Tier 2 pictures can be decoded progressively and output independently of pictures in Tier 3 through Tier 7. More generally, for any value of $k = 1, \dots, 7$ a Tier k picture is decodable if all immediately-preceding Tier 1 through Tier k pictures, inclusive, in the video stream have been decoded. *This requires that for tier values $k = 2, 3, 4$ or 5 if a picture is signalled as Tier k , then there shall be at least one Tier $(k-1)$ picture signalled between this RAP and the next RAP in decode order.* The exception is for pictures with tiers 6 and 7 that do not depend on other tier 6 and 7 pictures.

Depending on the GOP structures, all tier numbers between 1 and 7 may not be allocated to pictures and there may be a gap between the highest tier number used for reference pictures (1,2,3,4 or 5) and tier number 6 or 7. A single gap is permitted between the highest tier number used for reference pictures and tier number 6 or 7.

Tier number "0" is reserved for future use. "PVR_assist_tier_pic_num" field shall always be present for each picture when either tier framework and sub-stream framework or a combination is used. This also requires "data_field_length" to be set to a value greater than "0".

In the tier framework, if the tier number of a picture has a value of "6" or "7", then the picture shall be considered a discardable picture and may not belong to a decodable sub-sequence.

In addition, in the tier framework other parameters such as "PVR_assist_tier_m_cumulative_frames" and "PVR_assist_tier_m" are included to signal the minimum number for pictures intended to be extracted and decoded per each 1 second interval for a particular trick mode speed and higher. The following describes the use and setting of these syntax elements:

The number of pictures signalled from Tiers 1 through n where $1 < n < 6$ should be approximately half the number of pictures per every consecutive 1,0 second interval of the video stream, and the pictures should be evenly spread, to provide a smooth 2x trick mode. The complementary fields "PVR_assist_tier_m_cumulative_frames" and "PVR_assist_tier_m" may be signalled for this purpose.

The premise behind these two syntax elements is that if a sufficient number of pictures are provided to fulfil smooth 2x playback, then there will be a sufficient number of pictures to also render smooth playback of speeds higher than 2x.

For example, if 30 of every 60 pictures per second are signalled with Tiers 1 to n with these complementary fields, then it is possible to provide a 2x playback of 60 pictures per second from the 30 signalled pictures in every 1,0 second interval, or equivalently 60 signalled pictures can be decoded from every 2,0 second interval. Likewise, smooth 4x playback can be fulfilled with 15 of the signalled pictures in every 1,0 second interval.

D.3.3.3 Examples of tier number assignment (informative)

When a PVR application starts extracting a subsequence beginning at a RAP, its *decodability entry point* (DEP) is defined to be the RAP from which all pictures of this extracted subsequence can be fully reconstructed. Note that DEP is the RAP if it contains an IDR picture; otherwise, the DEP could be the previous RAP.

For all values of k from 1 to 6, a Tier k picture after a RAP is decodable and fully reconstructable if the respective tier number is signalled for each and every picture belonging to Tiers 1 through k that are located between the Tier k picture's DEP and the Tier k picture.

The GOP depicted in figure D.2 illustrates that every other picture may be signalled with Tiers 1 through 4. In figure D.2, the first and second rows depict picture output order and decode order, respectively; the third row shows the respective tier number of each picture in decode order.

A wide range of playback speeds are possible from Tier 1 pictures only (i.e. very fast) to higher tier numbers. A PVR application may provide alternate speeds with the pictures in Tiers 1 to $(k-1)$ and a portion of the pictures in tier k . In some cases the display of some pictures may be repeated to avoid imposing the decoder to run beyond its capabilities; in other cases to maintain speed accuracy. Using the signalled tier numbers, a PVR application may select the appropriate set of pictures for a particular trick mode without causing a decoder to process pictures faster than 1x.

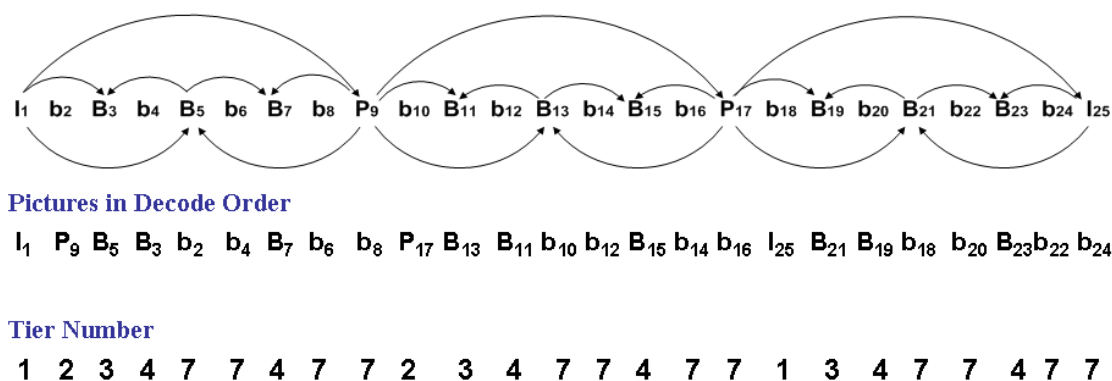

Figure D.2

In figure D.3, 2x trick mode may be rendered by decoding every other picture. In some cases, a PVR may render a 2x playback speed by decoding the pictures in tiers 1 to 3 and repeating the output of each picture once.

The tier framework can also be used to signal discardable pictures, or different categories of discardable pictures. For instance, with an MPEG-2 like GOP with three B pictures between reference pictures, the middle B picture of every trio can be signalled as a Tier "6" picture and the other two as Tier "7" pictures. This facilitates retention of the temporal sampling of the video when pictures need to be discarded.

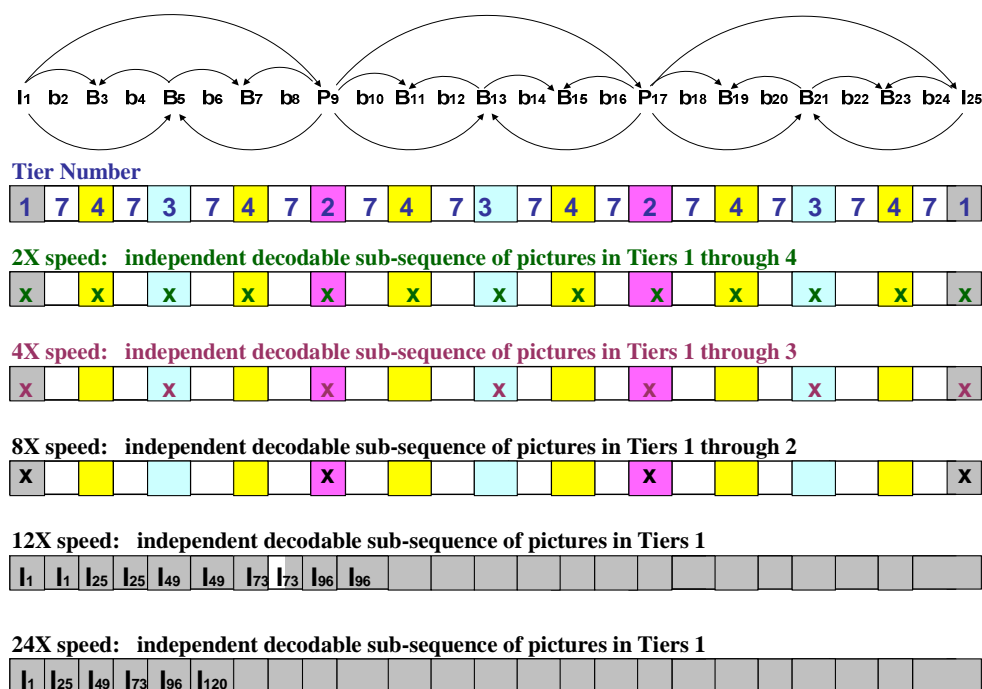

Figure D.3

D.3.4 Sub-stream framework

D.3.4.1 Background (informative)

This method is based on a sub-stream framework, which relieves the PVR device from the burden of determining the subset of pictures needed to fulfil a trick play speed. To achieve a pre-defined trick-mode speed, the PVR device is hypothetically supposed to decode a signalled sub-stream, select the pictures to display and choose their display duration. Each defined sub-stream is signalled on a picture basis, and may be guaranteed to be decodable by a compliant decoder. Note that this requires the "data_field_length" to be set to a value greater than "0" and the "PVR_assist_tier_pic_num" field be present for each picture.

This framework may also facilitate switching between different playback speeds on a real-time basis.

Playback speed information assists in signalling one or more sub-streams corresponding to respective pre-defined playback speeds. Up to four speeds may be signalled per picture to signal that this picture belongs to a corresponding extractable sub-stream, and each extractable sub-stream is associated with one of 15 playback speeds.

Furthermore, picture interdependencies as described in clause D.3.3, might be used by the PVR device to achieve intermediate playback speeds.

Note that playback speed information does not define the features, trick mode strategies or the effective trick mode speed achieved by the PVR device.

D.3.4.2 Tier Signalling (normative)

"PVR_assist_tier_pic_num" shall be present for each picture. Note that this requires the "data_field_length" to be set to a value greater than "0". Coding of "PVR_assist_tier_pic_num" is defined in clause D.3.3. *If the stream contains signalling for both the tier and substream frameworks, there shall be no conflict in the value signalled in syntax element "PVR_assist_tier_m_cumulative_frames" and a speed associated with 2x.* If a conflict occurs, it is recommended that "PVR_assist_tier_m_cumulative_frames_present_flag" be set to "0" when "PVR_assist_substream_info_present_flag" is set to "1".

D.3.4.3 Playback speed information (normative)

Playback speed information should be used to signal one or more sub-streams deemed best by the encoder to fulfil respective playback speeds.

If "PVR_assist_substream_1x_decodable_flag" is set to a value of "1", sub-streams do not require any additional resources and throughput capabilities of a 1x decoder (as defined in clause D 3.4.4) when played at their pre-defined trick-mode speeds.

D.3.4.4 Sub-stream associated with a Playback speed (normative)

The following defines a sub-stream that is signalled with playback speed information as it is constructed by the encoder.

- A sub-stream is a fully decodable subset of pictures that can be extracted from the original stream.
- A sub-stream where the "PVR_assist_substream_1x_decodable_flag" is set to "1" obeys the following constraints:
 - Max bitrate constraint: The sum of sizes of "Number of pictures per second" consecutively decoded pictures in the sub-stream does not exceed the "VCL max size" indicated in table D.9.
 - Jitter constraint: Let " S " be the intended playback speed of the sub-stream relative to the original stream from which the sub-stream is extracted. *The maximum number of pictures in the original stream between two consecutive signalled pictures in the sub-stream, in display order, shall not exceed the following values:*
 - 2 if $S < 2$
 - $2 * \text{Ceil}(S-1)$ if $2 \leq S < 4$
 - $3 * \text{Ceil}(S)$ if $4 \leq S < 19$
 - $4 * \text{Ceil}(S)$ if $S \geq 19$

Where: "Ceil" is the upward rounding function.

Table D.9: VCL maximum size values

IRD	Frame rate (Hz)	Number of pictures per second	VCL max size
25 Hz or 30 Hz H.264/AVC SDTV	24 or 24 000 / 1 001	24	10 Mbits
	25	25	10 Mbits
	30 or 30 000 / 1 001	30	10 Mbits
25 Hz or 30 Hz H.264/AVC HDTV	24 or 24 000 / 1 001	24	25 Mbits
	25	25	25 Mbits
	30 or 30 000 / 1 001	30	25 Mbits
	50	50	25 Mbits
	60 or 60 000 / 1 001	60	25 Mbits
50 Hz or 60 Hz H.264/AVC HDTV	24 or 24 000 / 1 001	24	62,5 Mbits
	25	25	62,5 Mbits
	30 or 30 000 / 1 001	30	62,5 Mbits
	50	50	62,5 Mbits
	60 or 60 000 / 1 001	60	62,5 Mbits

D.3.4.5 Examples of sub-streams (informative)

Sub-streams are constructed on the encoding side to help the PVR devices perform pre-defined trick-play speeds. The GOP structures chosen by the encoder are constrained such that trick-mode operation is possible considering the PVR device's capabilities. However, the present document does not impose specific GOP structures, and the encoder still has to derive them in order to maximize the coding efficiency and to obey other constraints.

The PVR device may choose different strategies to achieve the desired trick-mode speed. The most common are as follows:

- Display evenly distributed pictures. The sub-stream depicted in figure D.4 shows an example achieving a 2x trick-mode display speed using this strategy.
- Display RAP and the middle of the GOP pictures. The sub-stream depicted in figure D.5 illustrates an example to achieve a 4x trick-mode display speed.
- Display only RAP pictures.

While constructing Sub-streams, the encoder infers implicitly such a trick-mode strategy, and when "PVR_assist_substream_1x_decodable_flag" is set to "1", it ensures that even a 1x capable decoder may perform it.

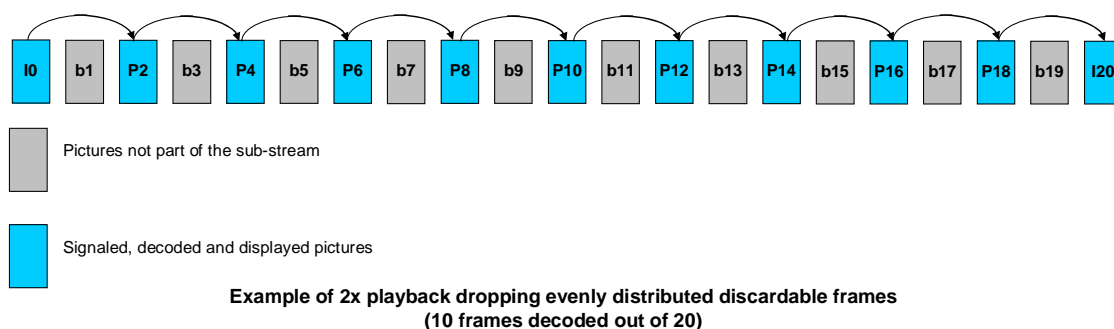

Figure D.4

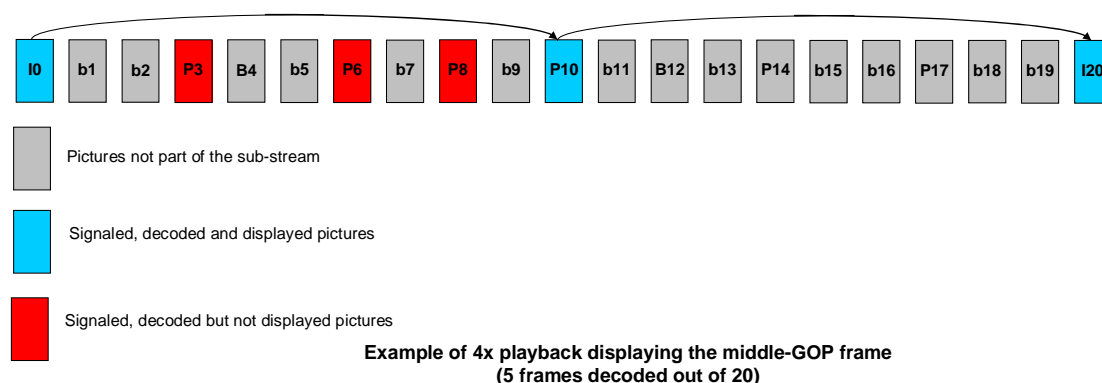

Figure D.5

D.3.5 Segmentation signalling

Segmentation information provided in the PVR assist information enhances the implementation of PVR applications with the following:

- 1) Segment (chapter) identification.
- 2) Program identification.
- 3) Start of a segment.
- 4) End of a segment.
- 5) Start of a program.
- 6) End of a program.
- 7) Location of scene change.

The rules for transmission of segmentation information and associated receiver behaviour are outside the scope of the present document.

NOTE: Other standards also supply methods to signal segmentation. It is possible multiple methods may be employed with a single service. In such case, the service operator should take care to ensure matching information is supplied via each method used. If a conflict exists, the method documented in this annex should be used.

D.3.6 PVR Assistance Signalling Syntax

Table D.10: PVR_assist_information data field

Syntax	No. bits	Mnemonic
PVR_assist_information() {		
data_field_tag	8	uimsbf
data_field_length	8	uimsbf
if (data_field_length > 0) {		
PVR_assist_tier_pic_num	3	uimsbf
PVR_assist_block_trick_mode_present_flag	1	bslbf
PVR_assist_pic_struct_present_flag	1	bslbf
PVR_assist_tier_next_pic_in_tier_present_flag	1	bslbf
PVR_assist_substream_info_present_flag	1	bslbf
PVR_assist_extension_present_flag	1	bslbf
if (PVR_assist_block_trick_mode_present_flag == "1") {		
PVR_assist_pause_disable_flag	1	bslbf
PVR_assist_fwd_slow_motion_disable_flag	1	bslbf
PVR_assist_fast_fwd_disable_flag	1	bslbf
PVR_assist_rewind_disable_flag	1	bslbf
PVR_assist_reserved_0	4	"0000"
}		
if (PVR_assist_pic_struct_present_flag == "1") {		
PVR_assist_pic_struct	4	uimsbf
PVR_assist_reserved_0	4	"0000"
}		
if (PVR_assist_tier_next_pic_in_tier_present_flag == "1") {		
PVR_assist_tier_next_pic_in_tier	7	uimsbf
PVR_assist_reserved_0	1	"0"
}		
if (PVR_assist_substream_info_present_flag == "1") {		
for (i = 0; i < 4; i++) {		
PVR_assist_substream_flag_i	1	bslbf
}		
PVR_assist_substream_speed_info_present_flag	1	bslbf
PVR_assist_substream_1x_decodable_flag	1	bslbf
PVR_assist_reserved_0	2	"00"
if (PVR_assist_substream_speed_info_present_flag == "1") {		
for (i = 0; i < 4; i++) {		
PVR_assist_substream_speed_idx_i	4	uimsbf
}		
}		
}		
if (PVR_assist_extension_present_flag == "1") {		
PVR_assist_segmentation_info_present_flag	1	bslbf
PVR_assist_tier_m_cumulative_frames_present_flag	1	bslbf
PVR_assist_tier_n_mmco_present_flag	1	bslbf
PVR_assist_reserved_0	5	"00000"
if (PVR_assist_segmentation_info_present_flag == "1") {		
PVR_assist_seg_id	8	uimsbf
PVR_assist_prg_id	16	uimsbf
PVR_assist_seg_start_flag	1	bslbf
PVR_assist_seg_end_flag	1	bslbf
PVR_assist_prg_start_flag	1	bslbf
PVR_assist_prg_stop_flag	1	bslbf
PVR_assist_scene_change_flag	1	bslbf
PVR_assist_reserved_0	3	"000"
}		
}		
if (PVR_assist_tier_m_cumulative_frames_present_flag == "1") {		
PVR_assist_tier_m	3	uimsbf
PVR_assist_tier_m_cumulative_frames	5	uimsbf
}		
}		

Syntax	No. bits	Mnemonic
if (PVR_assist_tier_n_mmco_present_flag == "1") {		
PVR_assist_tier_n_mmco	3	uimsbf
PVR_assist_reserved_0	5	"00000"
}		
}		
for (i=0; i<n; i++) {		
PVR_assist_reserved_byte	8	uimsbf
}		
}		
}		

Semantics:

data_field_tag: This shall have the value "0x03".

data_field_length: This indicates the length of this descriptor excluding the "data_field_tag" and "data_field_length" fields. A value of "0" for this field indicates that the encoding constraints as specified in clause 1.2 shall be met.

PVR_assist_tier_pic_num: The tier number of the picture associated with this PVR assistive information equals this value. The lowest tier number is equal to "1" and the highest tier number is equal to "7". A value of "0" is reserved for future use.

PVR_assist_block_trick_mode_present_flag: This flag can be set to "1" at a non-RAP picture only if its value at the prior RAP picture was set to "1". It shall be set to "1" when the following flags are present:

- 1) PVR_assist_pause_disable_flag.
- 2) PVR_assist_fwd_slow_motion_disable_flag.
- 3) PVR_assist_fast_fwd_disable_flag.
- 4) PVR_assist_rewind_disable_flag.

PVR_assist_pict_struct_present_flag: this field shall be set to "1" only if the video stream is an AVC stream and the "PVR_assist_pict_struct" field is present. Otherwise it shall be set to "0".

NOTE 1: If "PVR_assist_pict_struct_present_flag" is set to "0" and the AU_information data field is included, then "pic_struct" information may be available in the AU_information data field.

PVR_assist_tier_next_pic_in_tier_present_flag: This field shall be set to "1" when the "PVR_assist_tier_next_pic_in_tier" is present; otherwise it shall take the value "0".

PVR_assist_substream_info_present_flag: this field shall be set to "1" when values are present for the four flags corresponding to "PVR_assist_substream_flag_i" = 0 to 3, and for "PVR_assist_substream_speed_info_present_flag".

PVR_assist_extension_present_flag: this field shall be set to "1" if any of the following flags is set to "1":

- 1) PVR_assist_segmentation_info_present_flag.
- 2) PVR_assist_tier_m_cumulative_frames_present_flag.
- 3) PVR_assist_tier_n_mmco_present_flag.

Otherwise it shall be set to "0". In some cases, these extension flags may be provided only with pictures corresponding to RAPs.

PVR_assist_pause_disable_flag: The value of this flag shall be implied to be "0" unless provided explicitly in this field. This flag is set to "1" to signal disabling pause until the next RAP picture. The value of this flag at a non-RAP picture shall be equal to its value at the prior RAP picture.

PVR_assist_fwd_slow_motion_disable_flag: The value of this flag shall be implied to be "0" unless provided explicitly in this field. This flag is set to "1" to signal disabling forward slow motion, including frame stepping, until the next RAP picture. The value of this flag at a non-RAP picture shall be equal to its value at the prior RAP picture.

PVR_assist_fast_fwd_disable_flag: *The value of this flag shall be implied to be "0" unless provided explicitly in this field. This flag is set to "1" to signal disabling fast forward until the next RAP picture. The value of this flag at a non-RAP picture shall be equal to its value at the prior RAP picture.*

PVR_assist_rewind_disable_flag: *The value of this flag shall be implied to be "0" unless provided explicitly in this field. This flag is set to "1" to signal disabling rewind, including reverse slow motion and frame stepping, until the next RAP picture. The value of this flag at a non-RAP picture shall be equal to its value at the prior RAP picture.*

PVR_assist_pic_struct: *This shall reflect the "pic_struct" value of the AU in the AVC elementary stream (ES). If the ES carries the "Picture Timing SEI Message" with the "pic_struct" field, this shall be equal to that value. If "pic_struct" is not carried within the ES, then this value should reflect that of Table D-1 of ITU-T Recommendation H.264 / ISO/IEC 14496-10 [16].*

PVR_assist_tier_next_pic_in_tier: The value of this field indicates the relative location in decoding order of the next picture in the video stream with the tier number equal to "PVR_assist_tier_pic_num". A value of "0" indicates the next picture in decoding order. A value of "127" indicates that the relative location of the next picture sharing the same tier is not known.

NOTE 2: The "PVR_assist_tier_next_pic_in_tier" field may be associated with any picture, but it is recommended that this field is not used in real-time applications where low encoding delay is desired.

PVR_assist_substream_flag_i: *This field shall be set to "1" to signal that the associated picture is to be extracted to construct the sub-stream whose playback speed is indicated by "PVR_assist_substream_speed_idx_i". This flag shall be set to "0" if "PVR_assist_substream_speed_idx_i" is equal to "0000".*

PVR_assist_substream_speed_info_present_flag: *This field shall be set to "1" when "PVR_assist_substream_speed_idx_i" is not equal to "0000" for 'i' in the range "0" through to "3" inclusive.*

PVR_assist_substream_1x_decodable_flag: *This field shall be set to "1" when all sub-streams follow the constraints in clause D.3.4.4.*

PVR_assist_substream_speed_idx_i: When set to a non-zero value, this field provides the speed for the extractable sub-stream containing the pictures identified by "PVR_assist_substream_flag_i" = "1", while a zero value is used to avoid defining a sub-stream. The value of "PVR_assist_substream_speed_idx" is used to look-up the corresponding trick mode speed value in table D.11. A non-zero value of "PVR_assist_substream_speed_idx" indicates a sub-stream in accordance to clause D.3.4.4. *The value of "PVR_assist_substream_speed_idx_i" at a non-RAP picture shall be equal to its value at the prior RAP picture.*

NOTE 3: "PVR_assist_substream_speed_idx_i" may be associated with any picture but it is recommended to be provided only with RAP pictures. If possible, it is also recommended to avoid changes to "PVR_assist_substream_speed_idx_i".

Table D.11: Trick mode index to speed values

Index	Trick Mode Speed
0	No defined sub-stream
1	1,25
2	1,5
3	2,0
4	2,5
5	3,0
6	4,0
7	5,0
8	6,0
9	8,0
10	10,0
11	12,0
12	16,0
13	20,0
14	24,0
15	30,0

PVR_assist_segmentation_info_present_flag: *This field shall be set to "1" if the "PVR_assist_segmentation_info" field is present. Otherwise it shall be set to "0".*

NOTE 4: The "PVR_assist_segmentation_info" field may be associated with any picture but it is recommended that "PVR_assist_segmentation_info" is only associated with the first and last pictures of each segment and when scene changes are indicated.

PVR_assist_tier_m_cumulative_frames_present_flag: *This field shall be set to "1" if the "PVR_assist_tier_m" field and "PVR_assist_tier_m_cumulative_frames" are present. Otherwise it shall be set to "0".*

NOTE 5: The "PVR_assist_tier_m_cumulative_frames_present_flag" may be associated with any picture but it is recommended to be set only on RAP pictures.

PVR_assist_tier_n_mmco_present_flag: *This field shall be set to "1" if the "PVR_assist_tier_n_mmco" field is present. Otherwise it shall be set to "0".*

NOTE 6: The "PVR_assist_tier_n_mmco_present_flag" may be associated with any picture but it is recommended to be set only on RAP pictures.

PVR_assist_seg_id: *This field conveys the "id" of the segment to which the picture belongs. "PVR_assist_seg_id" shall be sent in ascending order resuming at program start and beginning at 0. A value of "255" is used to indicate an undefined segment id.*

PVR_assist_prg_id: This field conveys the "id" of the program to which the picture belongs. The information provided in this field can be used to obtain the title or other attributes of the program from program guide information. The "id" of a program for a particular program guide information service has to be available to the encoder to provide this field. A value of "65535" is used to indicate an undefined program id.

PVR_assist_seg_start_flag: *This field shall be set to "1" on the first picture in presentation time order of a segment. Otherwise it shall be set to "0". This segment is identified by the "PVR_assist_seg_id" field.*

PVR_assist_seg_end_flag: *This field shall be set to "1" on the last picture in presentation time order of a segment. Otherwise it shall be set to "0". This segment is identified by the "PVR_assist_seg_id" field.*

PVR_assist_prg_start_flag: *This field shall be set to "1" on the first picture in presentation time order of a program. Otherwise it shall be set to "0". This program is identified by the "PVR_assist_prg_id" field.*

PVR_assist_prg_stop_flag: *This field shall be set to "1" on the last picture in presentation time order of a program. Otherwise it shall be set to "0". This program is identified by the "PVR_assist_prg_id" field.*

PVR_assist_scene_change_flag: *This field shall be set to "1" at the first display-order picture of a new scene that carries this flag. Note that the present document does not define "scene change".*

PVR_assist_tier_m: This field is the tier number associated with "PVR_assist_tier_m_cumulative_frames". The value of this field should be chosen to signal a sufficient number of frames via "PVR_assist_tier_m_cumulative_frames" which would provide for smooth playback speeds of 2x and above. The value of this field should be chosen to provide less than or equal to half of the number of frames per second of the original frame rate.

PVR_assist_tier_m_cumulative_frames: This field conveys the value of the intended minimum number of extractable frames per second from tier 1 through "PVR_assist_tier_m".

PVR_assist_tier_n_mmco: This field represents the smallest tier number below which MMCOs can be ignored by decoders during trick-play modes. If this field is set to "7", then this signals that MMCOs could be present on any tier signalling reference pictures. If this field is set to "1", then this signals that the video stream does not contain MMCOs.

PVR_assist_reserved_byte: This field allows for future PVR assist information to be conveyed in the stream.

Annex E (normative): Supplementary Audio Services

E.1 Overview

Supplementary audio (SA) services provide an additional audio soundtrack that provides an additional feature or function over and above that provided by the main audio stream. The SA stream may be provided using one of two schemes:

- "Broadcast mix": pre-mixed by the broadcaster and offered as an alternative audio stream.
- "Receiver mixed": mixed in the receiver under the control of signalling provided by the broadcaster plus some limited control of the user.

This annex only deals with receiver-mixed SA services.

Examples of SA services include audio description for the visually impaired, audio for the hearing impaired ("Clean Audio") and a director's commentary. The language used in this annex is mainly in terms of an audio description service although it is equally applicable to all SA applications.

Audio description (AD) delivers a description of the scene. It is intended to aid understanding and enjoyment particularly, but not exclusively, for viewers who have visual impairments.

Clean Audio refers to audio providing improved intelligibility. It is targeted for viewers with hearing impairments, but can as well serve as improvement for listening in noisy environments like airplanes.

Loud sound effects or music could make the added supplementary audio hard to discern so an important requirement is to adjust, on a passage-by-passage basis, the relative level of programme sound in the mix which the SA user hears. The programme maker is best able to determine the level under controlled conditions when authoring the SA information to modulate the level of programme sound in the SA-capable receiver so suitable SA information is thus transmitted within the SA stream.

Individual SA users will have different aural acuity, describers (of AD) will have different styles of delivery (voice pitch and timbre), several voices may be used to describe one programme and there are, in practice, differences in audio signal level for different home receivers. An essential requirement is for the user to be able to adjust the volume of the SA signal to suit his/her condition.

The ability to optionally mix one or more supplementary additional audio channels with the main programme sound can have other applications, including multi-language commentaries, use for interactivity, and educational purposes.

E.2 Syntax and semantics

SA control information is coded in PES_private_data within the PES encapsulation of the coded SA component in accordance with ITU-T Recommendation H.222.0 / ISO/IEC 13818-1 [1].

Table E.1: AD_descriptor

Syntax	value	No. of Bits	Identifier
AD_descriptor {			
Reserved	1111	4	bslbf
AD_descriptor_length		4	bslbf
AD_text_tag	0x4454474144	40	bslbf
version_text_tag		8	bslbf
AD_fade_byte	0xXX	8	bslbf
AD_pan_byte	0xYY	8	bslbf
if (version_text_tag == 0x31) {			
Reserved	0xFFFFFFFF	24	bslbf
}			
if (version_text_tag == 0x32) {			
AD_gain_byte center	0xUU	8	bslbf
AD_gain_byte front	0xVV	8	bslbf
AD_gain_byte surround	0xWW	8	bslbf
}			
Reserved	0xFFFFFFFF	32	bslbf
}			

AD_descriptor_length: The number of significant bytes following the length field (i.e. 8 or 11).

AD_text_tag: A string of 5 bytes forming a simple and unambiguous means of distinguishing this from any other PES_private_data. A receiver which fails to recognize this tag should not interpret this audio stream as audio description.

version_text_tag: The AD_text_tag is extended by a single ASCII character version designator (here "1" indicates revision 1). *Descriptors with the same AD_text_tag but a higher version number shall be backwards compatible with the present document* - the syntax and semantics of the fade and pan fields will be identical but some of the reserved bytes may be used for additional signalling.

AD_fade_byte: Takes values between 0x00 (representing no fade of the main programme sound) and 0xFF (representing a full fade). Over the range 0x00 to 0xFE one lsb represents a step in attenuation of the programme sound of 0,3 dB giving a range of 76,2 dB. The fade value of 0xFF represents no programme sound at all (i.e. mute). The rate of signalling and the expected behaviour of a decoder to changes in fade byte are described below.

AD_pan_byte: Takes values between 0x00 representing a central forward presentation of the audio description and 0xFF, each increment representing a $360/256$ degree step clockwise looking down on the listener (i.e. just over 1,4 degrees, see figure E.2). The rate of signalling and the expected behaviour of a decoder are described below.

AD_gain_byte_center: Represents a signed value in dB. Takes values between 0x7F (representing +76,2 dB boost of the main programme centre) and 0x80 (representing a full fade). Over the range 0x00 to 0x7F one lsb represents a step in boost of the programme centre of 0,6 dB giving a maximum boost of +76,2 dB. Over the range 0x81 to 0x00 one lsb represents a step in attenuation of the programme centre of 0,6 dB giving a maximum attenuation of -76,2 dB. The gain value of 0x80 represents no main centre level at all (i.e. mute). The rate of signalling and the expected behaviour of a decoder to changes in gain byte are described below.

AD_gain_byte_front: As AD_gain_byte_center, applied to left and right front channel.

AD_gain_byte_surround: As AD_gain_byte_center, applied to all surround channels.

The maximum rate of signalling of fade, pan and gain values is determined by the number of audio PES packets per second for that SA stream. For efficiency several access units (AUs) of audio are typically encapsulated within one PES packet and the fade and pan values in each AD_descriptor are deemed to apply to each AU encapsulated within, and which commences in, that PES packet. In typical efficient encapsulation fade and pan values are transmitted every 120 ms to 200 ms. This allows the control over the attack and decay of a fade where a particular gap in the narrative permits.

An AD decoder must maintain the relative timing between the decoded AD signal and the decoded programme sound signal and between the appropriate fade, pan and gain values and the decoded description signal.

During programmes for which there is no description there is little reason to transmit an SA stream of continual silence; in these cases the bitrate accorded to SA may be reassigned for other purposes. Decoders should therefore be able to respond promptly to the restoration of the SA component at the start of a described programme.

In the case of AD, the streams for programme sound and for AD are distinguished in the PSI by the use of the ISO_639_language descriptor. The audio_type field within the descriptor associated with programme sound is typically assigned the value 0x00 ("undefined") whilst the equivalent descriptor associated with AD has its audio_type field assigned the value 0x03 ("visual impaired commentary"). If a service has AD in several languages the PMT reference to each stream will have the appropriate ISO_639_language_code and the AD-capable decoder should discriminate between them on the basis of the preferred language chosen in the user settings.

In the case of Clean Audio, the streams for programme sound and for Clean Audio are distinguished in the PSI by the use of the ISO_639_language descriptor. The audio_type field within the ISO_639_language descriptor associated with main programme sound is typically assigned the value 0x00 ("undefined") whilst the equivalent descriptor associated with Clean Audio has its audio_type field assigned the value 0x02 ("hearing impaired").

In all cases, the supplementary_audio_descriptor in the PSI (as defined in EN 300 468 [6]) should be used to unambiguously identify the different types and purpose of the audio streams, and this information overrides the audio_type field.

E.3 Coding for Audio Description SA services

AD content is voice-only and is conveyed as a mono signal coded in accordance with ISO/IEC 11172-3 [9] or ISO/IEC 14496-3 [17] or TS 102 366 [12]. *The coding scheme used for the main audio service determines the coding scheme used for the description service (i.e. they shall use the same coding standard) and the sampling rate shall be the same for both services.*

The principles of processing in a SA decoder in the case of AD when main audio is stereo are shown diagrammatically in figure E.1.

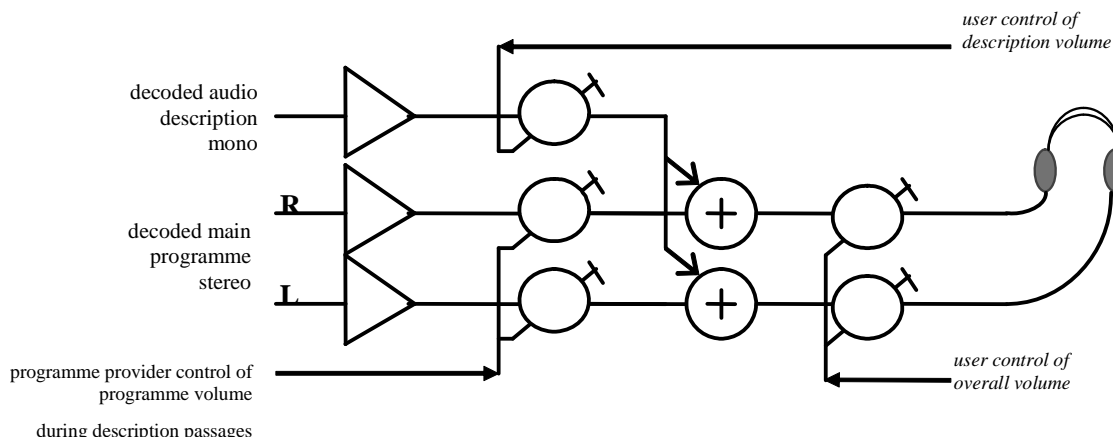

Figure E.1: Functionality of AD decoder processing

The level by which the main programme sound should be attenuated during a description passage is signalled in PES_private_data within the PES encapsulation of the coded SA component (as specified in ITU-T Recommendation H.222.0 / ISO/IEC 13818-1 [1]).

Encoding: Support for the encoding of AD is optional.

Decoding: Support for the decoding of AD is optional.

The signalled fade value is an unsigned byte value, 0x00 representing 0 dB, each increment representing a nominal 0,3 dB, 0xFE representing approximately -76,2 dB whilst the fade value 0xFF represents completely mute programme sound.

The signalled gain values for centre, front (L/R) and surround of the main programme represent a signed byte value, with 0x00 representing 0 dB, 0x7F representing +76,2 dB boost, 0x81 representing -76,2 dB and 0x80 complete mute. This allows a gain of -76,2 to +76,2 in steps of nominal 0,6 dB.

To obtain the attenuation/boost for left and right channel, the front gain value and the fade value are converted to factors and multiplied. This factor is then applied to left and right main channel. The attenuation/boost for a centre channel, if present, is obtained from centre gain value and fade value. The surround gain value is applied similarly to all present surround channels.

A pan control value is also included within the transmitted data structure, enabling the decoded SA signal (when delivered as a separate mono stream) to be panned around the sound stage of the main programme sound and thus allowing the programme maker to place the "describer" at any preferred position within the sound field. As with fade, transmitted pan is a byte value, 0x00 representing centre front where each increment represents about 1.4° clockwise looking down on the listener (see figure E.2). For stereo the pan value will be restricted to $\pm 30^\circ$ of the centre front (i.e. to the range 0xEB..0xFF and 0x00..0x15) but the syntax of the signalling allows for any future use in which an AD component might be provided with a surround-sound main programme audio.

The values of fade, pan and gain are signalled in a PES packet apply to each access unit of AD sound contained within that same PES packet. This allows fade, pan and gain to be relatively gradual or to be abrupt as the programme material allows.

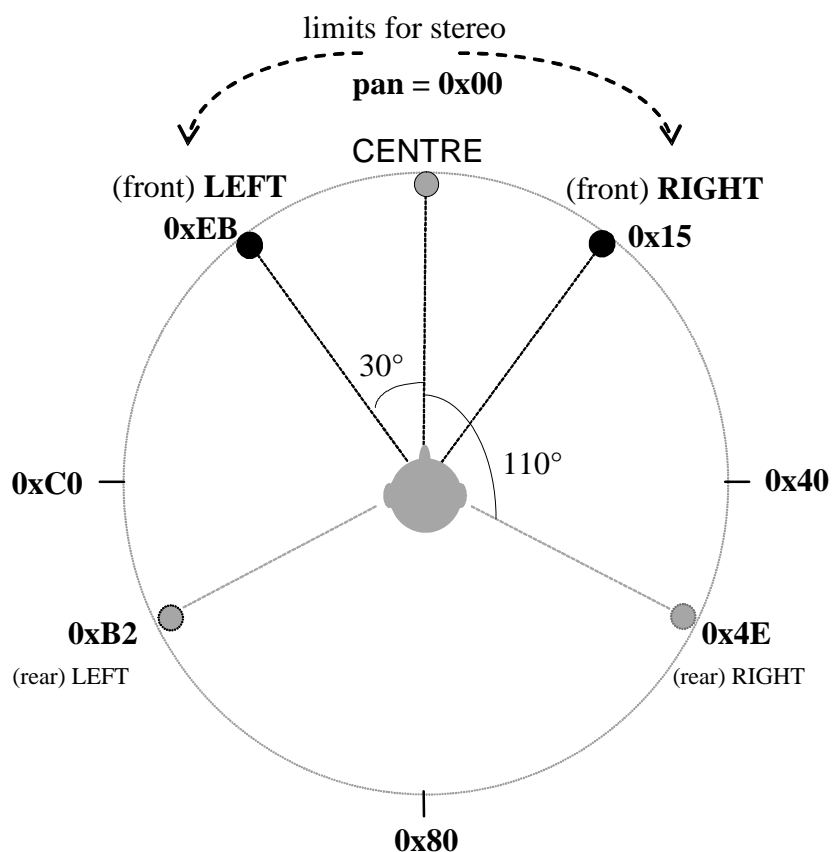

NOTE: Seen from above the listener; includes mapping onto multi-channel sound presentation.

Figure E.2: Interpretation of audio description pan value

E.4 Coding for Clean Audio SA services

In case an AD_descriptor is present in conjunction with a service signalled as audio_type 0x00 ("undefined"), the AD descriptor is utilized to provide a clean audio service. The level by which the main audio service should be attenuated for Clean Audio output is signalled in PES_private_data within the PES encapsulation of the main programme audio component (as specified in ITU-T Recommendation H.222.0 / ISO/IEC 13818-1 [1]). In this case, only **AD_gain_byte_center**, **AD_gain_byte_front** and **AD_gain_byte_surround** are evaluated. This allows for a dynamic level modification of channel groups in a surround sound setup.

Encoding: Support for the encoding of Clean Audio is optional.

Decoding: Support for the decoding of Clean Audio is optional.

The principles of processing in a SA decoder in the case of Clean Audio are shown diagrammatically in figure E.3.

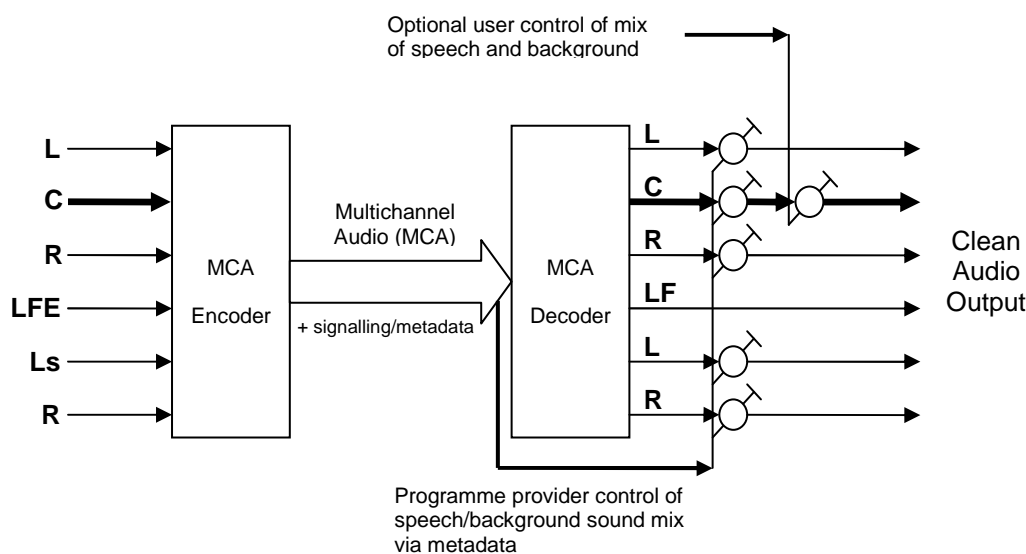

Figure E.3: Functionality of Clean Audio decoder processing

The audio processor should accentuate the level of the centre channel (containing the dialogue) and attenuate the other channels, according to the values signalled in the AD_descriptor. The level of the centre channel added should additionally be under user control to allow individual tailoring of the sound for audibility.

E.5 Decoder behaviour

If there is a valid AD descriptor in the encoded description signal for the selected service, the SA decoder should present the appropriate mix of programme sound and associate signal to the user, attenuating the programme sound by 0,3 dB per fade value increment and 0,6 dB per gain value step. If the SA decoder cannot support such small steps then the implemented attenuation should match the intended attenuation as closely as possible. For example if only -1 dB steps are possible then fade values of 0x00 and 0x01 should map to 0 dB, 0x02, 0x03 and 0x04 should map to -1 dB, 0x05, 0x06, 0x07 and 0x08 to -2 dB etc.

When fade and gain values are 0x00 (or in the absence of an SA stream for AD) the programme sound level should be unattenuated. Care should be taken to ensure that the default levels of programme sound and supplementary signal are consistent when fed with streams coding standard level signals. It is also important that the mono supplementary audio is matrixed to the stereo output so as to achieve a constant perceived volume as the supplementary audio is panned from stereo left through stereo centre to stereo right.

NOTE 1: E.g. using a model based on constant power as the description is panned across the stereo sound stage.

NOTE 2: The perceived loudness level of the main programme audio may well vary between different broadcast services. If the main programme audio is derived from a system using gain control metadata, for example AC-3, then the perceived loudness of the programme dialogue should be constant but it is likely to be different to that of a service for which the programme sound is delivered as MPEG-1 Layer II. For any receiver which can decode main audio sources other than MPEG-1 Layer II, the manufacturer may need to consider implementing different default gain levels for the audio description signal to provide a reasonable match of loudness to that of the programme dialogue. The ability of the user to adjust the relative level of description should nevertheless be retained.

In a stereo environment the SA decoder should interpret any pan values outside the ranges 0xEB..0xFF and 0x00..0x15 in the following manner. Pan values from 0x16 to 0x7F inclusive should be mapped to the value 0x15 (i.e. stereo hard right). Pan values from 0x80 to 0xEA should be mapped to the value 0xEB (i.e. stereo hard left).

When the user selects a new service or if the SA decoder detects an error in, or absence of, the AD descriptor in the encoded SA signal, the SA decoder should have a strategy which leads to muting the decoded description signal, restoring the programme sound to its default unfaded amplitude and setting the effective fade, pan and gain values to 0x00. This restoration should not be abrupt - it is recommended that under such conditions the value of fade and of pan are ramped to the default values (0x00) over a period of at least 1 second. Equally, if the SA stream component is suddenly regained the implemented value of fade, pan and gain should be ramped to the signalled values from the default values (0x00) over a similar period.

E.6 Decoder user indicators

Description, in the case of AD, is typically confined to gaps in the programme narrative; these opportunities are therefore dependent on the programme. Some programmes are more suited to description than others; one may be effectively self-describing whilst another (e.g. news or a studio interview) might offer no opportunity for descriptive interpolation. Receiver implementations of SA should therefore allow the user to confirm that, in what may be extended gaps between description passages, description silence does not necessarily imply failure in delivery of the service or in the receiving equipment.

Many potential users of AD will be visually impaired. The user interface should not, therefore, rely solely on visual clues (lights or on-screen display logos) to indicate status (e.g. presence or absence of description). Audible indications are desirable and designers should consider how to distinguish different states using, for example, contrasting tones.

Conversely, many potential users of Clean Audio will be hearing impaired. The user interface, in this case, should rely more on visual feedback than audible indications.

Annex F (informative): Encoding Guidelines to Enable Trick Play Support of H.264/AVC Streams

F.1 Introduction

F.1.1 Overview

This annex discusses informative guidelines on the encoding of H.264/AVC Bitstreams to enable support of trick play modes. MPEG-2 personal video recording devices and services are increasingly being used in the marketplace and it is reasonable to expect this trend to continue. As industry migrates to the H.264/AVC standard, it is therefore also reasonable to believe that consumers will expect the functionality of their H.264/AVC PVR services to be at least as good as (and most likely better than) their MPEG-2 counterparts. It is important to recognize that the unofficial widely-adopted methods of MPEG-2 encoding directly enabled many of the techniques currently used to achieve trick mode functionality. The same is true of VC-1 encodings. Note that MPEG-2 video can be encoded in a manner that makes PVR very difficult but since most encoders encoded bitstreams in a "PVR-friendly" manner, this was not an issue with MPEG-2 Bitstreams. Again, the same is true of VC-1 encodings. Currently, the lack of syntax and semantics constraints on H.264/AVC Bitstreams combined with the rich set of video coding tools in H.264/AVC allows for a wide variety of potential bitstreams with some being very problematic for any type of sophisticated bitstream manipulation such as the trick modes in H.264/AVC PVR implementations. For these reasons, the guidelines in this appendix were constructed to assist encoders to create H.264/AVC Bitstreams that are "PVR-friendly" while not imposing significant constraints that would impact coding efficiency. Note that this annex is informative since it is understood that enabling trick play support is an optional feature that may or may not be appropriate depending on its intended use. In the case of an MVC transmission, this annex currently applies only to the base layer.

F.1.2 Technical Requirements

One class of trick play modes consists of the desire to play back the video at a speed that is a multiple of real-time playback. Let a Nx trick play mode (where N is a positive number greater than 1) represent video playback at a speed of N times real-time playback. For example, a 3x trick play mode may be desired which would allow a user to fast forward through a program three times as fast as normal playback, i.e. in one-third the time. It is often desired for these trick modes to be relatively "smooth", i.e. an Nx trick mode (where N is a positive integer) requires (at least approximately) every N th picture in the bitstream to be displayed. For example, repeating every thirtieth picture ten times would not constitute a "smooth" 3x trick mode using this definition. This "smooth" requirement may not be required for very fast trick modes like 15x or 30x fast forward since the human visual system cannot process such rapid motion. However, this requirement is desirable for trick modes such as 2x and 3x fast forward to obtain the satisfactory visual appearance of moving objects during the trick play.

In general, without any encoding constraints, the minimum requirement to implement trick modes is for the decoding to be done at the same speed as the desired trick mode to ensure that every prediction region is available for use in the motion compensation process, e.g. a decoder that runs at three times the normal speed of decoding is needed to guarantee 3x fast forward functionality. Note that this is a significant increase from the minimum requirement needed for normal playback. This approach has been done before for trick play with MPEG-2 standard definition content but is not practical or cost effective for many current and future applications. For example, decoding HD H.264/AVC video at three times the normal decoding speed is currently not possible in a cost-efficient fashion and even if this increased capability were made available in the future, it may not be desirable because of the increased cost relative to the minimum requirement for normal playback. This leads to a key technical assumption for the cost-effective implementation of trick play modes:

- Encoding intended for trick-play will be done in such a way that it does not burden decoders to decode pictures at a rate faster than normal playback to implement a trick play mode.

F.2 Discardable Pictures

Many PVR implementations drop pictures in the bitstream (i.e. skip over and do not present these pictures to the decoder) to circumvent the need to decode bitstreams at speeds that are a multiple of real-time decoding. The visual effect of decoding at a multiple of real-time decoding can then be achieved using a normal decoder. This is only possible if a dropped picture is not needed for display and also not needed as a reference frame for another picture that is needed for display. These pictures are termed "discardable" pictures. The following clauses will discuss how the "discardable" pictures concept was exploited in MPEG-2 trick play implementations and then how this same concept can be used to implement H.264/AVC trick play.

F.2.1 MPEG-2 Discardable Pictures

In the MPEG-2 video standard, B-pictures are not allowed to be used as reference pictures for motion compensation. This has a significant benefit for trick play modes since any B-pictures in a MPEG-2 Bitstream can be dropped without affecting the decodability of other pictures. The "discardability" property of B-pictures is commonly used by many MPEG-2 trick mode implementations.

Figure F.1 illustrates the unofficial but widely-adopted MPEG-2 GOP structure, the IBBP GOP structure, which has two B-pictures placed between every pair of anchor I- and/or P-pictures. By dropping the B-pictures in this type of stream and passing the remaining pictures to the decoder, the visual effect of 3x fast forward trick play can be implemented with a decoder running at normal playback speed.

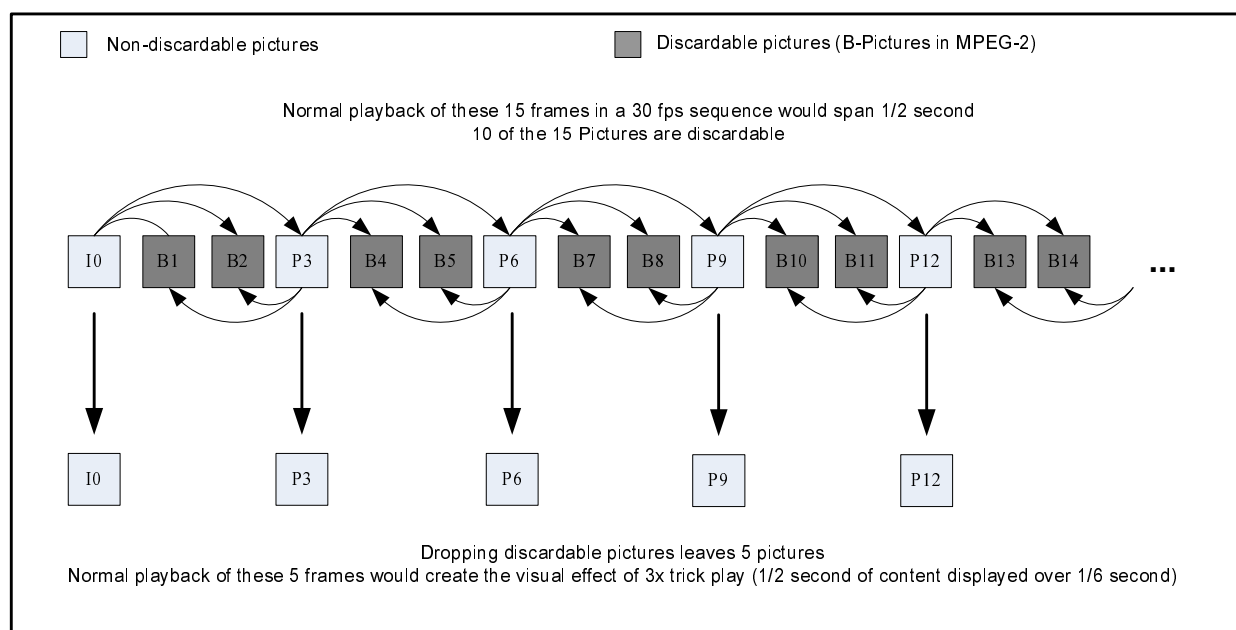

Figure F.1: Example of achieving a 3x trickplay mode from a common MPEG-2 GOP structure (IBBP)

Figure F.2 illustrates a MPEG-2 GOP structure, the IPPP GOP structure, where no B pictures are placed between every pair of anchor I- and/or P- pictures. Note that this structure is compliant to MPEG-2 but the technique of dropping B-pictures described above will not create a 3x trick play mode with this MPEG-2 coding structure since there are not enough B-pictures to drop (there is only one discardable picture at the end of the MPEG-2 GOP). In this case, a decoder that can run at N times normal decoding speed is necessary to support N times fast forward trick play since every picture is dependent on the previous picture in the MPEG-2 GOP.

Note that the problematic effect on PVR of a bitstream with a coding structure as shown in figure F.1 has often been overlooked and not usually an issue because this type of MPEG-2 GOP structure is rarely used in broadcast applications.

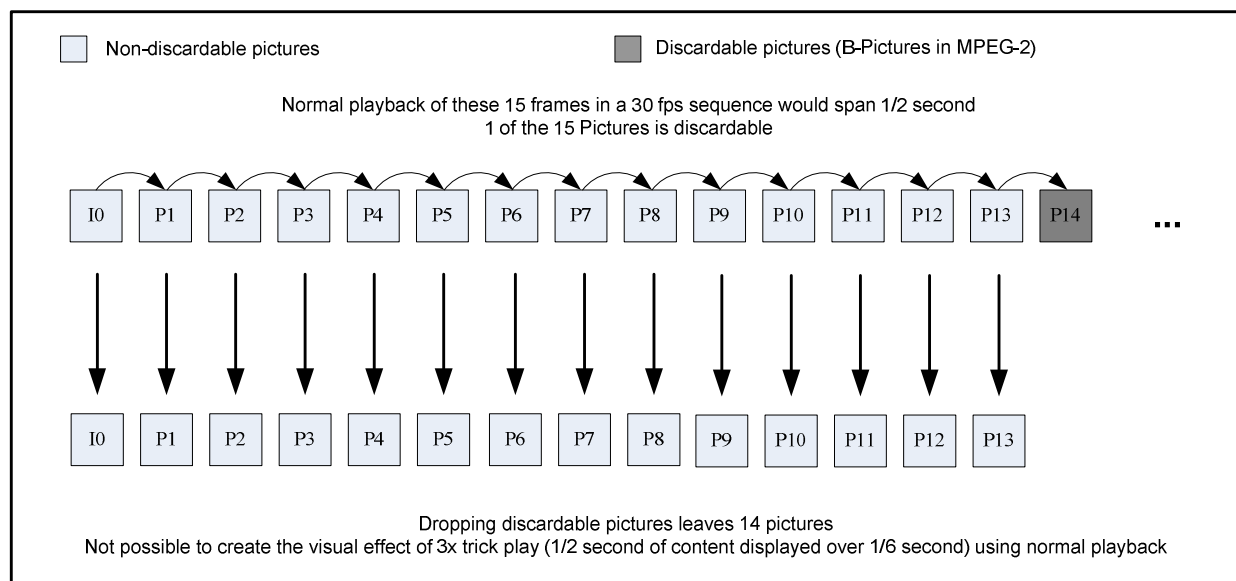

Figure F.2: Example of a compliant MPEG-2 GOP structure (IPPP) that cannot achieve 3x trick play by discarding pictures

F.2.2 H.264/AVC Discardable Pictures

The H.264/AVC compression standard has some substantial differences compared to MPEG-2 that significantly affect the picture coding structure and complicate trick mode implementations. These include the fact that B-pictures can be used as reference pictures for prediction, i.e. not all B-pictures are discardable as in MPEG-2. Note that the discardability of pictures is specifically indicated in the H.264/AVC standard by the `nal_ref_idc` flag in the NAL header (`nal_ref_idc = 0` indicates a discardable picture). Therefore, for H.264/AVC Bitstreams, the important factor in trick mode functionality is the location of discardable pictures, not the location of B-pictures as in MPEG-2. The presence of discardable pictures determines the feasibility of dropping pictures that are not needed for display to achieve the visual effect of a trick play mode.

F.2.3 Discardable Pictures and Trick Play Speeds

The percentage of pictures in the bitstream that are discardable determines the maximum trick play speed that could be achieved by just dropping discardable pictures while operating the decoder at normal processing speeds. The formula below can be used to associate the percentage of discardable pictures with the maximum trick play speed that could be achieved by dropping discardable pictures:

$$\text{Trick Play Speed} = 100 / (100 - X) \text{ where } X \text{ is the percentage of discardable pictures.}$$

Examples using common ratios of discardable pictures are listed in table F.1.

Table F.1: Discardable Picture Percentages and Maximum Achievable Trick Play Speeds by discard process

Percentage of Discardable Pictures	Maximum Trick Play Speed Achievable By Dropping Pictures
16 % (1/6 of the pictures)	1,2x
20 % (1/5 of the pictures)	1,25x
25 % (1/4 of the pictures)	1,33x
33 % (1/3 of the pictures)	1,5x
50 % (1/2 of the pictures)	2x
66 % (2/3 of the pictures)	3x
75 % (3/4 of the pictures)	4x

NOTE: Trick play speeds slower than the maximum achievable by dropping pictures can always be created by choosing to display some of the discardable pictures.

F.2.4 Smooth Trick Play and Compression Efficiency

Constraining a certain percentage of pictures in the bitstream to be discardable is necessary to enable the technique of dropping discardable pictures to achieve a trick play mode. However, it is important to recognize that determining the interval period between pictures where this percentage is constrained has a tradeoff between whether a smooth trick play is achieved and the coding structure which can impact coding efficiency. For example, figures F.3 and F.4 both illustrate coding structures with 66 % of its pictures as discardable pictures (in both cases 10 of the 15 total pictures are discarded).

Figure F.3 has a more regular discardable picture structure and represents the further requirement of 2 out of every 3 pictures to be discardable. Dropping the discardable pictures in figure F.3 will result in smooth 3x playback since every third picture in the original stream remains. However, note that the tradeoff for the ability to create a smooth 3x trick play is that the discardable picture structure places a tight constraint on the encoding which could reduce compression efficiency.

Ten out of the 15 total pictures in figure F.4 are discardable as in figure F.3, but its discardable picture structure is not as regular. Dropping the discardable pictures in figure F.4 will not result in a smooth trick play experience as in figure F.3. However, note that dropping discardable pictures can still be used to achieve the visual effect of playing through the content at three times the speed (since 5 frames remain) but without the serious constraint on the encoding.

NOTE: Although structure may not always guarantee smooth playback, there are methods that could create an appearance of smoother playback by means outside of this appendix.

To enable trick play support and still facilitate maximum compression efficiency, the percentage of discardable pictures will be calculated over the length of a H.264/AVC GOP (which, at the maximum 5 second time interval between the DTS of successive RAPs, may be up to 300 pictures). Encoding for the smoothest trick-play will distribute discardable pictures evenly in time throughout the H.264/AVC GOP.

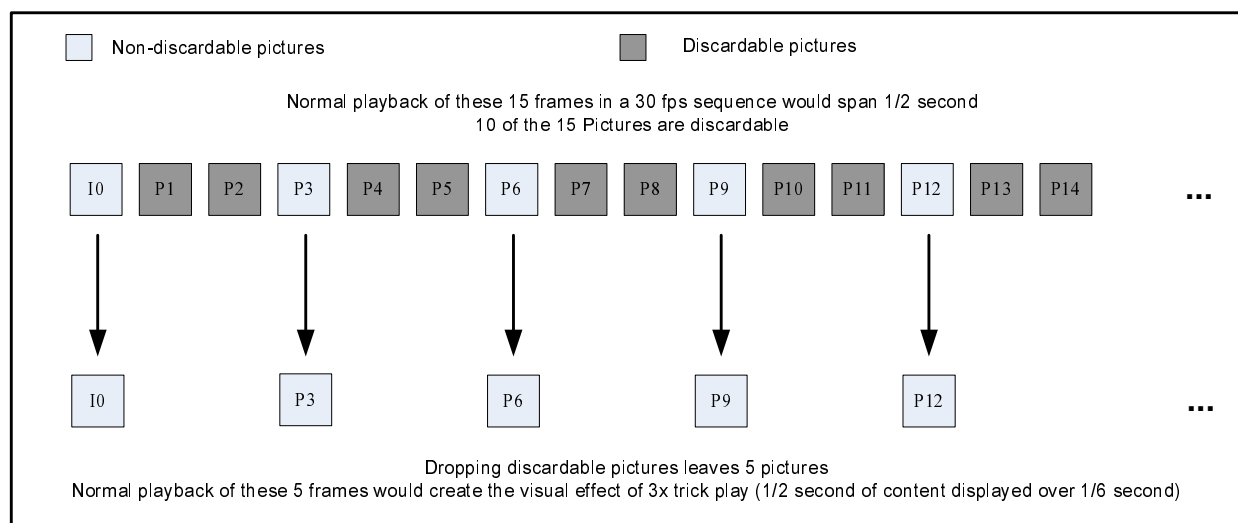
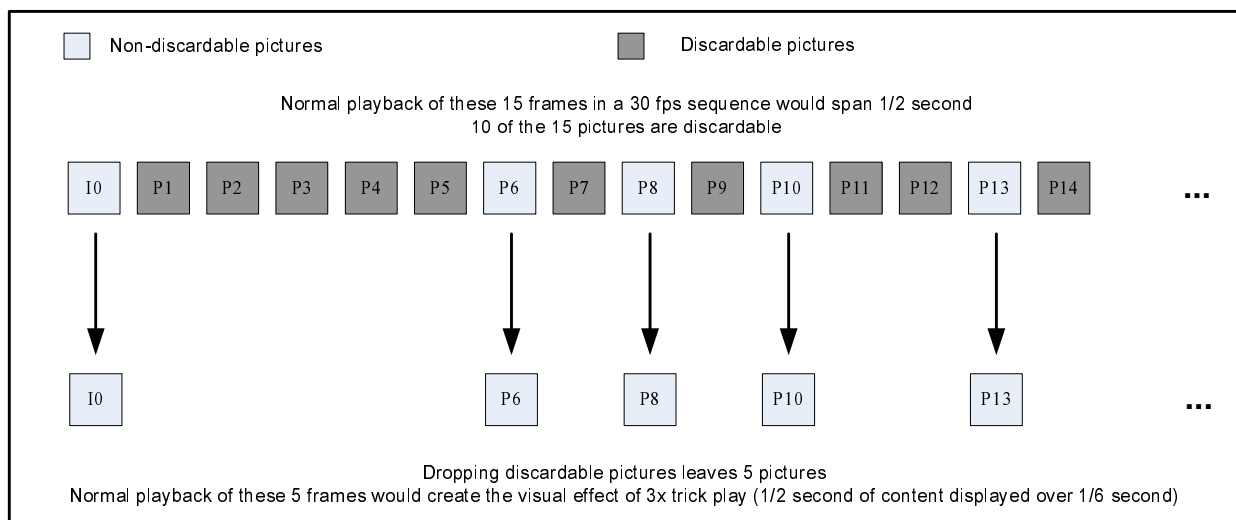

Figure F.3: Coding Structure with 2 Out of Every 3 Pictures as Discardable Pictures (the Discardable Pictures are inserted consistently)



**Figure F.4: Coding Structure with 10 out of Every 15 Pictures as Discardable Pictures
(The Discardable Pictures Are Not Inserted Consistently)**

F.2.5 Impact of Adaptive Encoding on Guidelines

It is well known that greater compression efficiency can be achieved by encoders that are able to dynamically adapt to content. This adaptation may occur in the middle of encoding a H.264/AVC GOP, especially with real-time encoders. For this reason, it is often difficult for an encoder to forecast a resulting property of the H.264/AVC GOP such as the number of discardable pictures in a H.264/AVC GOP before it actually encodes the H.264/AVC GOP since it may decide to change its methodology while encoding the H.264/AVC GOP. On the other hand, there is typically a general encoding methodology that will be used if the content being encoded is not drastically different from what the encoder is expecting.

Annex G (informative): Random Access Point Considerations for SVC

G.1 Scope

This annex contains encoder and decoder implementation guidelines to cover the cases where SVC Base layer RAPs are transmitted more frequently than SVC Enhancement layer RAPs. Note that decoder implementations that follow the guidelines in this annex may require additional complexity beyond typical SVC decoding.

G.2 Overview

The specification for SVC RAPs in clause 5.8.1.6 enables SVC Base layer RAPs to be transmitted more frequently than SVC Enhancement layer RAPs. Increasing the time interval between SVC Enhancement layer RAPs can significantly improve coding efficiency for enhancement layers, since more SVC Enhancement layer representations (SVC dependency representation with `dependency_id` greater than 0) can be inter-predicted using previously decoded pictures as references. However, increasing the time interval between SVC Enhancement layer RAPs also increases the average time before IRDs can start decoding the SVC Enhancement layer representations.

This annex specifies optional encoder and decoder implementation guidelines that enable SVC IRDs to reduce the time for an IRD to output decoded pictures of the complete SVC Bitstream by initially decoding the SVC Bitstream at the first SVC RAP that is received, irrespective of whether this SVC RAP represents an SVC Base layer RAP or an SVC Enhancement layer RAP. If the initial SVC RAP represents an SVC Base layer RAP only, the SVC IRD starts decoding and displaying the base layer and switches to enhancement layer decoding when the first SVC Enhancement layer RAP is received.

This method can be beneficially used in a number of transmission scenarios, which include all types of broadcast transmission systems, e.g. satellite, terrestrial, cable or IP channels. The benefits may include increased error resilience as well as reduced bitrate and channel change time.

Clause G.3 provides the encoder implementation guidelines while clause G.4 provides those for the decoder.

G.3 Encoder Implementation Guidelines

The following encoder implementation guidelines should be followed by an SVC encoder in order to enable SVC IRDs to implement the techniques in clause G.4 to efficiently start decoding at any received RAP:

- 1) Access units with PTS less than the PTS(rap) do not follow any access unit (in decoding order) with PTS greater than the PTS(rap), where PTS(rap) is the Presentation Time Stamp of an access unit that represents an SVC Enhancement layer RAP.
- 2) The dependency representations with a particular value of `dependency_id` greater than 0 in access units with PTS greater than PTS(rap) do not reference any picture with PTS less than PTS(rap) through inter-prediction, where PTS(rap) is the Presentation Time Stamp of an access unit that represents an SVC Enhancement layer RAP for that particular value of `dependency_id`.
- 3) The difference between the Presentation Time Stamp of an SVC Enhancement layer RAP with PTS(rap) and the Presentation Time Stamp of any access unit that follows the SVC Enhancement layer RAP in decoding order but precedes it in output order should not be greater than 150 milliseconds.
- 4) The number of required frame stores in the decoded picture buffer (specified by `max_dec_frame_buffering`, if present) for decoding a particular layer associated with a particular value of `dependency_id` does not exceed the value of `MaxDpbFrames` for any layer with `dependency_id` greater than the particular value of `dependency_id`.

Each of these constraints is designed to simplify the decoder implementation as specified in clause G.4. An SVC encoder may choose to omit any of these guidelines but should carefully consider the potential effect on decoder implementations that may depend on these constraints for robust implementation.

G.4 Decoder Implementation Guidelines

The following decoder implementation guidelines could be followed by an SVC IRD in order to start decoding at any received RAP.

It is suggested that an SVC IRD starts decoding an SVC Bitstream at the first SVC RAP that it receives, independent of whether this SVC RAP represents an SVC Base layer RAP or an SVC Enhancement layer RAP. If the initial SVC RAP represents an SVC Enhancement layer RAP, decoding can continue as normal.

If the initial SVC RAP represents an SVC Base layer RAP only, the SVC IRD can start decoding and displaying the base layer and switch to enhancement layer decoding when the first SVC Enhancement layer RAP is received. The switching from base layer decoding to enhancement layer decoding at a non IDR picture is not directly specified in annex G of ITU-T Recommendation H.264 / ISO/IEC 14496-10 [16] and could vary between different SVC IRD implementations resulting in different visual results for this transition.

For example, an SVC IRD capable of performing dual decoding (simultaneous parallel decoding of the base and enhancement layers) could decode the base layer starting with the SVC Base layer RAP and additionally decode the enhancement layer starting at the next SVC Enhancement layer RAP. For all access units that precede the SVC Enhancement layer RAP in output order, the SVC IRD can output the decoded SVC Base layer representations (SVC dependency representation with `dependency_id` equal to 0). For the SVC Enhancement layer RAP and all access units that follow the SVC Enhancement layer RAP in output order, the SVC IRD can output the decoded SVC Enhancement layer representations. This dual decoding system may not require the encoder implementation guidelines specified in clause G.3 to be followed but the use of dual decoding for a single stream may be computationally and/or cost prohibitive. The encoder implementation guidelines specified in clause G.3 are intended to simplify the switching between base and enhancement layer decoding and permit implementations with a single decoding process.

In clauses G.4.1 and G.4.2, two example decoding processes enabling the switching from base to enhancement layer decoding after random access are given. The guidelines in these clauses outline the main steps required for implementing the switching between base and enhancement layer decoding. Note that the clauses do not cover all the details required in an implementation and there may be different decoding processes to achieve similar results.

Clause G.4.1 outlines a decoding approach where pictures around the transition point may be skipped.

Clause G.4.2 outlines a decoding approach where there is a seamless transition between SVC Base layer pictures (SVC layer picture with `dependency_id` equal to 0) and SVC Enhancement layer pictures (SVC layer picture with `dependency_id` greater than 0) around the transition point.

Clause G.4.3 outlines approaches for reducing the visibility of the transition between displaying SVC Base layer pictures and SVC Enhancement layer pictures after accessing a bitstream at an SVC Base layer RAP.

For the following guidelines in this annex, `MaxDIdRAP` represents the maximum value of `dependency_id` that is associated with an SVC RAP in the SVC Bitstream and `MaxDId` represents the maximum value of `dependency_id` present in an SVC RAP in the SVC Bitstream. For a particular SVC RAP referred to as `rapX`, `MaxDIdRAP` and `MaxDId` may be specified by the functional relationships `MaxDIdRAP(rapX)` and `MaxDId(rapX)`, respectively.

G.4.1 Decoding process with output picture skipping

If an SVC IRD starts decoding an SVC Bitstream at an SVC RAP with `MaxDIdRAP` less than `MaxDId`, which is referred to as `rapA` in the following text, the SVC IRD may use a decoding process similar to the following steps:

- 1) The SVC IRD decodes the SVC layer picture with `dependency_id` equal to `MaxDIdRAP(rapA)` for the SVC RAP `rapA`.
- 2) Where `rapB` represents the next SVC RAP in the SVC Bitstream that follows `rapA` in decoding order and has `MaxDIdRAP(rapB)` greater than `MaxDIdRAP(rapA)`, the SVC IRD continues decoding all SVC layer pictures with `dependency_id` equal to `MaxDId(rapA)` of the access units that precede `rapB` in decoding order.

- 3) If rapB represents an IDR picture for dependency_id equal to MaxDIdRAP(rapB), the SVC layer picture with dependency_id equal to MaxDIdRAP(rapB) for rapB is decoded.
- 4) If rapB does not represent an IDR picture for dependency_id equal to MaxDIdRAP(rapB), SVC layer pictures with dependency_id equal to MaxDIdRAP(rapB) are decoded for rapB and all access units that follow rapB in decoding order but precede it in output order.
- 5) For each access unit with a Presentation Time Stamp greater than or equal to the Presentation Time Stamp of rapA and less than the Presentation Time Stamp of rapB, the SVC IRD outputs the decoded SVC layer pictures for dependency_id equal to MaxDIdRAP(rapA). If rapB does not represent an IDR picture for dependency_id equal to MaxDIdRAP(rapB), no pictures are output for the access units that follow the rapB in decoding order but precede it in output order.
- 6) For all access units for which SVC layer pictures with dependency_id less than MaxDId(rapA) are output, the decoded SVC layer pictures should be re-sampled, before displaying, in order to match the resolution of the dependency representation with dependency_id equal to MaxDId(rapA). The re-sampling operation is specified for a smooth transition at SVC RAPs by which the dependency_id of the decoded SVC layer pictures is increased. Note that the enhancement layer resolution is determined prior to the output of the first picture in the base layer for the SVC IRD to perform proper re-sampling.
- 7) If MaxDIdRAP(rapB) is less than MaxDId(rapB), the SVC IRD continues decoding with step 2, where the SVC RAP rapA is replaced with the SVC RAP rapB and the SVC RAP rapB is determined as specified in step 2. Note that this step is only applicable to systems with more than two dependency representations.
- 8) If MaxDIdRAP(rapB) is equal to MaxDId(rapB), the SVC IRD continues decoding as specified in ITU-T Recommendation H.264 / ISO/IEC 14496-10 [16].

In figure G.1, the decoding process is illustrated as an example for accessing an SVC Bitstream at an SVC Base layer RAP. The decoding process starts with decoding the SVC Base layer representation for the SVC Base layer RAP and all access units that follow the SVC Base layer RAP and precede the SVC Enhancement layer RAP in decoding order.

- For the SVC Enhancement layer RAP and all access units that follow the SVC Enhancement layer RAP in decoding order, the SVC enhancement layer representations are decoded.
- For the SVC Base layer RAP and all access units that follow the SVC Base layer RAP in output order and precede the SVC Enhancement layer RAP in decoding order, the SVC Base layer representations are output.
- For the SVC Enhancement layer RAP and all access units that follow the SVC Enhancement layer RAP in output order, the SVC Enhancement layer representations are output.
- No picture is output for the access units that follow the SVC Enhancement layer RAP in decoding order but precede it in output order.

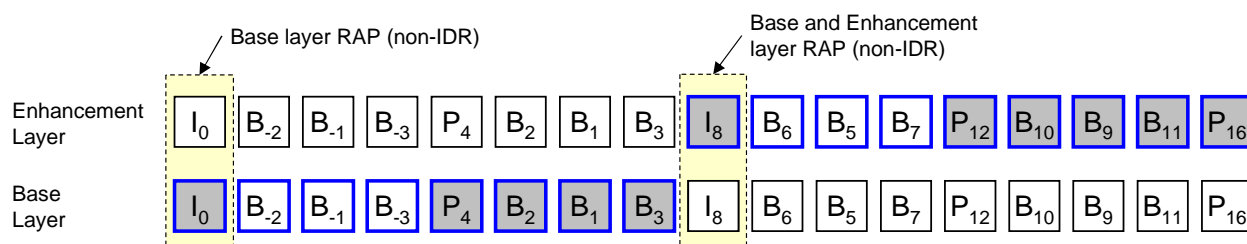

NOTE: The access units are displayed in decoding order (from left to right). The subscript numbers indicate the output order. The representations that are decoded are marked with blue frames; the representations that are output are marked grey.

Figure G.1: Illustration of the decoding process with output picture skipping when accessing a two-layer SVC Bitstream at an SVC Base layer RAP

G.4.2 Decoding process with seamless output

If an SVC IRD starts decoding an SVC Bitstream at an SVC RAP with MaxDIdRAP less than MaxDId , which is referred to as rapA in the following, the SVC IRD may use a decoding process similar to the following steps:

- 1) The SVC IRD decodes the SVC layer picture with dependency_id equal to $\text{MaxDIdRAP}(\text{rapA})$ for the SVC RAP rapA .
- 2) Where rapB represents the next SVC RAP in the SVC Bitstream that follows rapA in decoding order and has $\text{MaxDIdRAP}(\text{rapB})$ greater than $\text{MaxDIdRAP}(\text{rapA})$, the SVC IRD continues decoding all SVC layer pictures with dependency_id equal to $\text{MaxDId}(\text{rapA})$ of the access units that precede rapB in decoding order.
- 3) If rapB represents an IDR picture for dependency_id equal to $\text{MaxDIdRAP}(\text{rapB})$, the SVC layer picture with dependency_id equal to $\text{MaxDIdRAP}(\text{rapB})$ for rapB is decoded.
- 4) If rapB does not represent an IDR picture for dependency_id equal to $\text{MaxDIdRAP}(\text{rapB})$, the following steps apply:
 - a) For rapB , both the SVC layer picture with dependency_id equal to $\text{MaxDIdRAP}(\text{rapA})$ and the SVC layer picture with dependency_id equal to $\text{MaxDIdRAP}(\text{rapB})$ are decoded. The SVC layer picture with dependency_id equal to $\text{MaxDIdRAP}(\text{rapA})$ is inserted in the decoded picture buffer, while the SVC layer picture with dependency_id equal to $\text{MaxDIdRAP}(\text{rapB})$ is temporarily stored separately from the decoded picture buffer as decoding SVC layer pictures with dependency_id equal to $\text{MaxDIdRAP}(\text{rapA})$ continues.
 - b) The SVC IRD continues decoding all SVC layer pictures with dependency_id equal to $\text{MaxDIdRAP}(\text{rapA})$ of the SVC access units that follow rapB in decoding order and have a Presentation Time Stamp less than the Presentation Time Stamp of rapB .
 - c) All pictures in the decoded picture buffer are marked as "unused for reference" and the temporarily stored layer picture with dependency_id equal to $\text{MaxDIdRAP}(\text{rapB})$ for rapB is inserted in the decoded picture buffer in preparation for decoding SVC layer pictures with dependency_id equal to $\text{MaxDIdRAP}(\text{rapB})$.
- 5) For each access unit with a Presentation Time Stamp greater than or equal to the Presentation Time Stamp of rapA and less than the Presentation Time Stamp of rapB , the SVC IRD outputs the decoded SVC layer pictures for dependency_id equal to $\text{MaxDIdRAP}(\text{rapA})$.
- 6) For all access units for which SVC layer pictures with dependency_id less than $\text{MaxDId}(\text{rapA})$ are output, the decoded SVC layer pictures should be re-sampled, before displaying, in order to match the resolution of the dependency representation with dependency_id equal to $\text{MaxDId}(\text{rapA})$. The re-sampling operation is specified for a smooth transition at SVC RAPs by which the dependency_id of the decoded SVC layer pictures is increased. Note that the enhancement layer resolution is determined prior to the output of the first picture in the base layer for the SVC IRD to perform proper re-sampling.
- 7) If $\text{MaxDIdRAP}(\text{rapB})$ is less than $\text{MaxDId}(\text{rapB})$, the SVC IRD continues decoding with step 2, where the SVC RAP rapA is replaced with the SVC RAP rapB and the SVC RAP rapB is determined as specified in step 2. Note that this step is only applicable to systems with more than two dependency representations.
- 8) If $\text{MaxDIdRAP}(\text{rapB})$ is equal to $\text{MaxDId}(\text{rapB})$, the SVC IRD continues decoding as specified in ITU-T Recommendation H.264 / ISO/IEC 14496-10 [16].

In figure G.2 the decoding process is illustrated for an example of accessing an SVC Bitstream at an SVC Base layer RAP. The decoding process starts with decoding the SVC Base layer representation for the SVC Base layer RAP and all access units that follow the SVC Base layer RAP and precede the SVC Enhancement layer RAP in decoding order.

- For the SVC Enhancement layer RAP, both the SVC Base layer representation and SVC Enhancement layer representation are decoded. The decoded SVC Base layer representation is normally inserted in the decoded picture buffer while the decoded SVC Enhancement layer representation is stored in a temporary frame store.

- For the access units that follow the SVC Enhancement layer RAP in decoding order but precede it in output order, the IRD continues decoding the SVC Base layer representations. Before the first access unit that follows the SVC Enhancement layer RAP in both decoding and output order is decoded, all SVC Base layer representations in the decoded picture buffer are marked as "unused for reference" and the temporary stored SVC Enhancement layer representation (for the SVC Enhancement layer RAP) is inserted in the decoded picture buffer. The decoding process then continues with decoding the SVC Enhancement layer representations for all following access units.
- For the SVC Base layer RAP and all access units that follow the SVC Base layer RAP and precede the SVC Enhancement layer RAP in output order, the SVC Base layer representations are output. For the SVC Enhancement layer RAP and all access units that follow the SVC Enhancement layer RAP in output order, the SVC Enhancement layer representations are output.

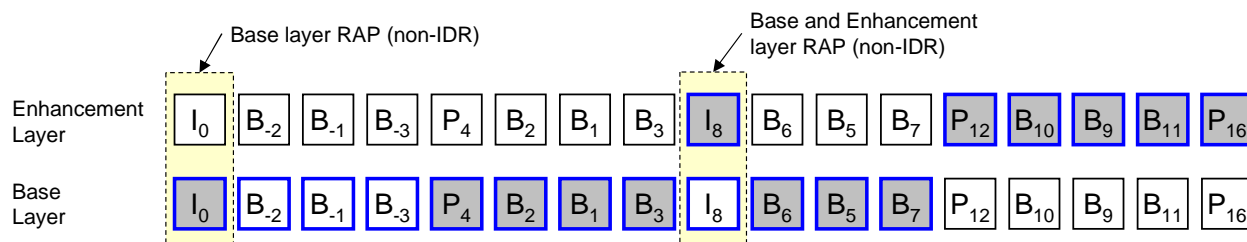

NOTE: The access units are displayed in decoding order (from left to right). The subscript numbers indicate the output order. The representations that are decoded are marked with blue frames; the representations that are output are marked grey.

Figure G.2: Illustration of the decoding process with seamless output when accessing a two-layer SVC Bitstream at an SVC Base layer RAP

G.4.3 Display Process at a Transition from Base to Enhancement Layer Decoding

This clause provides guidelines for reducing the visibility of the transition between displaying SVC Base layer pictures and SVC Enhancement layer pictures when accessing SVC Bitstream at an SVC Base layer RAP. An SVC IRD is not required to follow these guidelines.

For all pictures for which the SVC Base layer representations are output by the decoding process (see clauses G.4.1 and G.4.2), the decoded SVC Base layer representations should be re-sampled to the enhancement layer frame size before displaying.

If SVC Base layer pictures and SVC Enhancement layer pictures represent the same area of the source pictures, the transition between displaying re-sampled SVC Base layer pictures and SVC Enhancement pictures might be visible as a quality change in the displayed video signal. If the SVC Base layer pictures represent a subset of the source picture area that is represented by the SVC Enhancement layer pictures, the transition between displaying re-sampled SVC Base layer pictures and SVC Enhancement pictures might be more pronounced and appear to be a cut between different scenes. In the following text, two approaches are outlined which can be applied for reducing the visibility of a transition between displaying re-sampled SVC Base layer pictures and SVC Enhancement layer pictures:

- When SVC Base layer pictures and SVC Enhancement layer pictures represent the same area of the source pictures, the visibility of the transition between base and enhancement layer decoding can be reduced by applying a time-varying low-pass filter (before display) to the initial pictures that are displayed from the SVC Enhancement layer representation. For the first picture for which the SVC Enhancement layer representation is output, the cut-off frequency can be selected according to the ratio between the SVC Base layer picture and SVC Enhancement layer picture sizes. The cut-off frequency of the low-pass filter can then be continuously increased in output order until the SVC Enhancement layer pictures are displayed without the additional low-pass filtering. For example, this transition interval could be about 1 second.

- When the SVC Base layer picture represent a subset of the source picture area that is represented by the SVC Enhancement layer pictures, the visibility of the transition between base and enhancement layer decoding can be reduced by continuously increasing the cropping window for the initial pictures that are displayed from the SVC Enhancement layer representation. For the first SVC Enhancement layer representation that is output, only the portion of the picture that corresponds to the base layer cropping window can be displayed (after re-sampling it to the enhancement layer frame size). For the following SVC Enhancement layer representations, this cropping window can be continuously increased until it matches the enhancement layer cropping window specified in the bitstream. For example, this transition interval could be about 1 second. This approach of continuously increasing the cropping window could also be combined with the approach of applying a time-varying low-pass filter described above.

Annex H (normative): Frame Compatible Plano-Stereoscopic 3DTV

H.1 Scope

This annex contains encoder and decoder implementation guidelines for frame compatible plano-stereoscopic 3DTV systems. Such systems are built upon the existing H.264/AVC High Definition system and include the additional requirement and guidelines to deliver frame compatible plano-stereoscopic 3DTV services. Depending on the output resolution, interlace or progressive frame format, frame rate and 3DTV formatting arrangement, a frame compatible plano-stereoscopic 3DTV system supports the combinations described in the table H.1. All the other combinations that are not defined in the table H.1 remain optional and are left to the responsibility of the broadcaster or the service provider to ensure that systems for the proper delivery of services based on them are available. The term HDTV is used to refer to non frame compatible plano-stereoscopic 3DTV services (ie: 2D services). For frame compatible plano-stereoscopic 3DTV implementation guidelines refer to TS 101 547 "Frame compatible Plano-Stereoscopic 3DTV" [32].

Table H.1: Frame compatible mandated 3DTV formats/structures

IRD Class	Output resolution/Format	Frame rate	Frame compatible arrangement type
25 Hz	720 p	50 Hz	Top-and-Bottom, Side-by-Side
25 Hz	1 080 i	25 Hz	Side-by-Side
30 Hz	720 p	59,94/60 Hz	Top-and-Bottom, Side-by-Side
30 Hz	1 080 i	29,97/30 Hz	Side-by-Side
30 Hz	1 080 p	23,98/24 Hz	Top-and-Bottom, Side-by-Side

H.2 Frame compatible plano-stereoscopic 3DTV definition

25 Hz frame compatible plano-stereoscopic 3DTV IRD: IRD that is capable of decoding and displaying pictures based on a nominal video frame rate of 25 Hz or 50 Hz from H.264/AVC High Profile at Level 4 bitstreams as specified in the present document, in addition to providing the functionality of interpreting the specific plano-stereoscopic 3DTV signalling as specified in this annex.

25 Hz frame compatible plano-stereoscopic 3DTV Bitstream: bitstream which contains only H.264/AVC High Profile at Level 4 video at 25 Hz or 50 Hz frame rates as specified in the present document with the specific plano-stereoscopic 3DTV signalling as specified in this annex.

30 Hz frame compatible plano-stereoscopic 3DTV IRD: IRD that is capable of decoding and displaying pictures based on nominal video frame rates of 24 000/1 001 (approximately 23,98), 24, 30 000/1 001 (approximately 29,97), 30, 60 000/1 001 (approximately 59,94) or 60 Hz from H.264/AVC High Profile at Level 4 bitstreams as specified in the present document, in addition to providing the functionality of interpreting the specific plano-stereoscopic 3DTV signalling as specified in this annex.

30 Hz frame compatible plano-stereoscopic 3DTV Bitstream: bitstream which contains only H.264/AVC High Profile at Level 4 video at 24 000/1 001, 24, 30 000/1 001, 30, 60 000/1 001 or 60 Hz frame rates as specified in the present document with the specific plano-stereoscopic 3DTV signalling as specified in this annex.

H.3 System layer specifications common to all plano-stereoscopic 3DTV IRDs and Bitstreams

The specification in this clause applies to the following IRDs and Bitstreams:

- 25 Hz frame compatible plano-stereoscopic 3DTV IRD and Bitstream;
- 30 Hz frame compatible plano-stereoscopic 3DTV IRD and Bitstream.

H.3.1 General

Frame compatible plano-stereoscopic 3DTV IRDs and Bitstreams shall comply with the system layer specifications related to all H.264/AVC HDTV IRDs and bitstreams as defined in clause 4 with the extensions as specified in this annex.

H.3.2 Frame compatible plano-stereoscopic 3DTV Specific Program Elementary Stream descriptor

H.3.2.1 AVC_video_descriptor

For frame compatible plano-stereoscopic 3DTV:

Encoding: *The **AVC_video_descriptor** shall be used when appropriate. The syntax element **Frame_Packing_SEI_not_present_flag** shall be set to 0 in the **AVC_video_descriptor** to signal presence of frame packing arrangement SEI message within the coded video sequence (see clause H.4.2).*

Decoding: *The frame compatible plano-stereoscopic 3DTV IRD shall use this descriptor in order to identify the presence of the frame packing arrangement SEI message in the bitstream.*

H.4 Video specifications Common to all frame compatible plano-stereoscopic 3DTV IRDs and Bitstreams

The specification in this clause applies to the following IRDs and Bitstreams:

- 25 Hz frame compatible plano-stereoscopic 3DTV IRD and Bitstream;
- 30 Hz frame compatible plano-stereoscopic 3DTV IRD and Bitstream.

H.4.1 General

Frame compatible plano-stereoscopic 3DTV IRDs and Bitstreams shall comply with the common specifications to all H.264/AVC IRDs and bitstreams as defined in clause 5.5 with extensions as specified in this annex .

25 Hz frame compatible plano-stereoscopic 3DTV IRD and bitstreams shall comply with the specifications of 25 Hz H.264/AVC HDTV as defined in clause 5.7 with extensions as specified in this annex.

30 Hz frame compatible plano-stereoscopic 3DTV IRD and bitstreams shall comply with the specifications of 30 Hz H.264/AVC HDTV as defined in clause 5.7 with extensions as specified in this annex.

H.4.2 Supplemental Enhancement Information

Frame compatible plano-stereoscopic 3DTV IRDs shall support the use of frame packing arrangement SEI message in the conditions depicted in this clause.

Frame compatible plano-stereoscopic 3DTV bitstreams shall not use the Stereo Video information SEI message.

Frame compatible plano-stereoscopic 3DTV IRDs shall ignore any Stereo Video information SEI message.

H.4.2.1 Frame Packing Arrangement SEI Message

Encoding: The constraints defined below apply to frame compatible plano-stereoscopic 3DTV bitstreams and are made in order to support the formats listed in table H.1:

*When the AVC_video_descriptor has its **frame_packing_SEI_not_present_flag** syntax element equal to 0, the frame packing arrangement SEI shall be transmitted with each access unit. The syntax element **frame_packing_arrangement_repetition_period** shall be set to '0' (1b in Exp-Golomb code).*

*The syntax element **frame_packing_arrangement_id** shall be set to '0' (1b in Exp-Golomb code).*

The syntax element **frame_packing_arrangement_type** defines the arrangement of the left and right views inside an HDTV frame. In order to fulfil the frame compatible plano-stereoscopic 3DTV formats/structures listed in the table H.1, when present, **frame_packing_arrangement_type** should have one of the defined values: '3' for Side-by-Side, '4' for Top-and-Bottom, depending on the following conditions:

- for a 25 Hz frame compatible plano-stereoscopic 3DTV bitstream:
 - if the frame rate is 25Hz interlaced and if the decoded video resolution is 1080i, then the **frame_packing_arrangement_type** should be '3'.
 - if the frame rate is 50 Hz progressive and if the decoded video resolution is 720p, then the **frame_packing_arrangement_type** should be either '3' or '4'.
- for a 30 Hz frame compatible plano-stereoscopic 3DTV bitstream:
 - if the frame rate is 23,98 Hz or 24 Hz progressive and if the decoded video resolution is 1 080p, then the **frame_packing_arrangement_type** should be either '3' or '4'.
 - if the frame rate is 59,94 Hz or 60 Hz interlaced and if the decoded video resolution is 1080i, then the **frame_packing_arrangement_type** should be '3'.
 - if the frame rate is 60 Hz progressive and if the decoded video resolution is 720p, then the **frame_packing_arrangement_type** should be either '3' or '4'.

NOTE 1: The use of any other combination of frame format and frame packing arrangement type, not specified above is not required to be supported by frame compatible plano-stereoscopic 3DTV IRDs.

*Changes to frame packing arrangement SEI, including the **frame_packing_arrangement_type** shall only occur at a RAP with an IDR picture.*

NOTE 2: An IDR picture cancels all prior SEI messages. An IDR without a frame packing arrangement SEI indicates a switch in the video sequence from a frame compatible plano-stereoscopic 3DTV to an HDTV event.

NOTE 3: In the case of a switch from a frame compatible plano-stereoscopic 3DTV event to an HDTV event, transmission of a frame packing arrangement SEI with **frame_packing_arrangement_cancel_flag** = 1 starting at the first RAP with an IDR picture of the HDTV format content, may provide explicit confirmation at the video layer that such a format change has occurred. In the case of a switch from an HDTV event to a frame compatible plano-stereoscopic 3DTV event, transmission of a frame packing arrangement SEI with **frame_packing_arrangement_cancel_flag** = 1 starting at a RAP with an IDR picture of the HDTV format content, may provide an early indication of such a format change at the event boundary. Clause 6.5 of TS 101 154 "Frame compatible Plano-Stereoscopic 3DTV" [32] makes provisions concerning such format transitions.

In order to be consistent with the minimum capabilities in HDMI 1.4a [i.14] for plano-stereoscopic 3DTV:

- The syntax element **quincunx_sampling_flag** shall be set to '0';
- The syntax element **content_interpretation_type** shall be set to '1';
- The syntax elements **spatial_flipping_flag** and **frame0_flipped_flag** shall be set to '0'.

NOTE 4: The HDMI 1.4a specification does not provide all the information on the sub-sampling method, filters and how the views are ordered inside an HDTV frame. Therefore care should be taken on the use of any other value than the ones specified above.

The syntax elements **frame0_grid_position_x**, **frame0_grid_position_y**, **frame1_grid_position_x** and **frame1_grid_position_y** should be set to '0000'.

When **frame_packing_arrangement_type** is equal to '3' or '4', the following syntax elements shall be equal to '0':

- **field_views_flag**;
- **current_frame_is_frame0_flag**;
- **frame_packing_arrangement_extension_flag**.

NOTE 5: As specified in ITU-T Recommendation H.264 / ISO/IEC 14496-10 [16], any other value of the above listed syntax elements combined with a **frame_packing_arrangement_type** equal to '3' or '4' is reserved for future use.

The syntax elements **frame0_self_contained_flag** and **frame1_self_contained_flag** should be set to '0'.

Decoding: Frame compatible plano-stereoscopic 3DTV IRDs shall support the **frame_packing_arrangement** SEI message.

Frame compatible plano-stereoscopic 3DTV IRDs shall ignore frame packing arrangement SEI messages with a value of **frame_packing_arrangement_id** not equal to '0'.

25Hz frame compatible plano-stereoscopic 3DTV IRDs shall support the following values of **frame_packing_arrangement_type**:

- **frame_packing_arrangement_type** value '3' (Side-by-Side) shall be supported for 25 Hz, 1 080 lines vertical resolution interlaced video.
- **frame_packing_arrangement_type** values '3' (Side-by-Side) and '4' (Top-and-Bottom) shall be supported for 50 Hz, 720 lines vertical resolution progressive video.

30 Hz frame compatible plano-stereoscopic 3DTV IRDs shall support the following values of **frame_packing_arrangement_type**:

- **frame_packing_arrangement_type** value '3' (Side-by-Side) and '4' (Top-and-Bottom) shall be supported for 23,98 Hz or 24 Hz, 1080 lines vertical resolution progressive video.
- **frame_packing_arrangement_type** value '3' (Side-by-Side) shall be supported for 59,94 Hz or 60 Hz, 1 080 lines vertical resolution interlace video.

- *frame_packing_arrangement_type* value '3' (Side-by-Side) and '4' (Top-and-Bottom) shall be supported for 60 Hz, 720 lines vertical resolution progressive video.

*Frame compatible plano-stereoscopic 3DTV IRDs shall ignore the following syntax elements **field_views_flag, current_frame_is_frame0_flag, frame0_self_contained_flag, frame1_self_contained_flag, frame_packing_arrangement_extension_flag.***

Annex I (normative): Considerations for Encoding and Random Access for MVC Stereo Video

The following clauses give guidelines for allowing easy random access within MVC Stereo bitstreams. These guidelines are based on the Blu-ray Disc White Paper [i.16].

I.1 Video Sequence Structure

Figure I.1 shows the typical coded video sequence structure and frame and view dependencies of MVC Stereo video, as stored on a Blu-ray Disc. Broadcast video may, or may not, have a similar structure, though it is recommended. This is shown here for illustrative purposes.

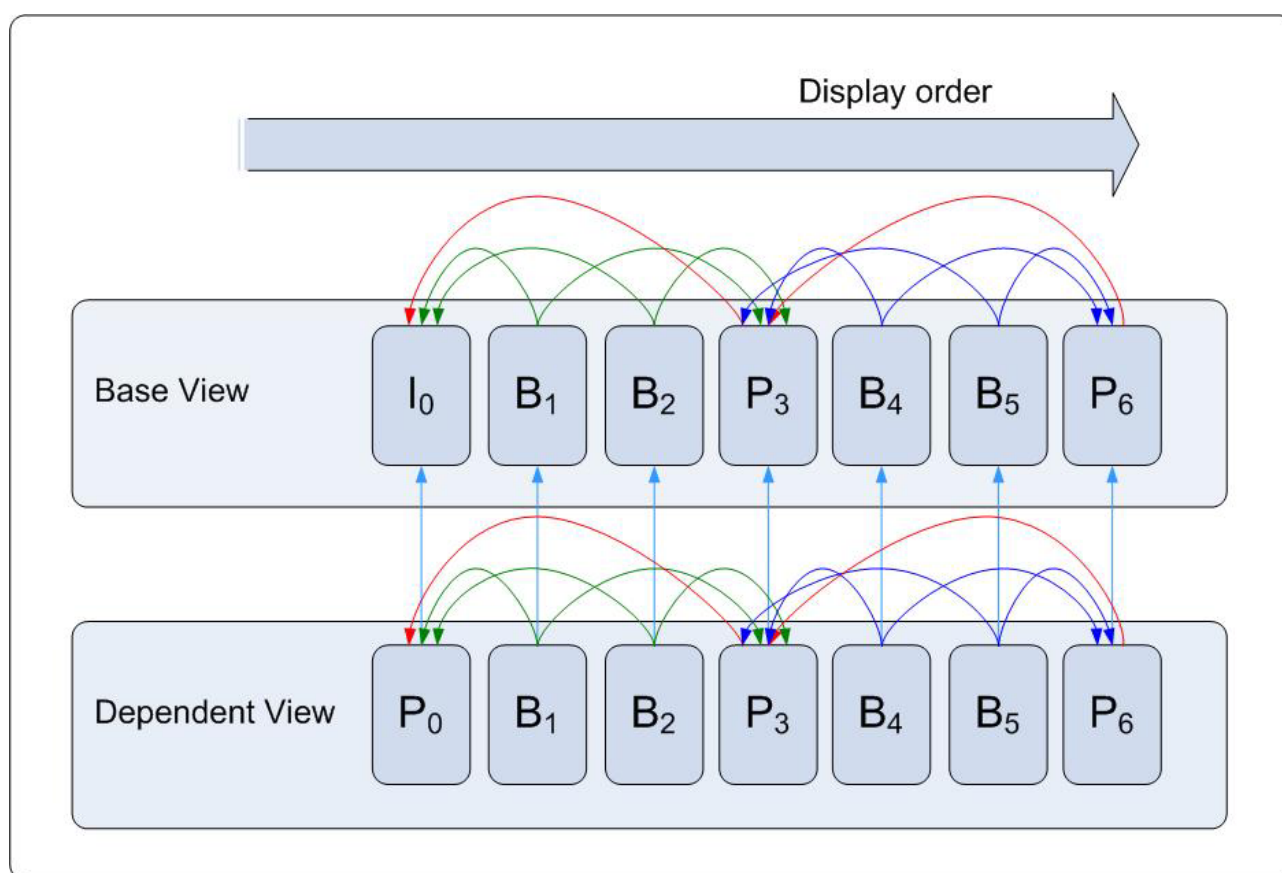

Figure I.1: Typical coded video sequence structure of MVC Stereo video

In order to enable quick random access, the following constraints apply:

- The first access unit in a coded video sequence in decoding order is an MVC Stereo RAP.
- In case the Dependent view component is a B picture component, then the corresponding view component of Base view video shall also be B picture component.
- In case the Dependent view component is a non-reference B picture component, the corresponding view component of Base view video shall also be a non-reference B picture component.
- The coded video sequence structure for Base view video stream and Dependent view video stream shall be the same, including:

- whether it is open or closed coded video sequence structure;
- the number of view components;
- the values of `nal_ref_idc` of a NAL unit with slice data for Base view component and `nal_ref_idc` of a NAL unit with slice data for the corresponding Dependent view component shall be the same;
- the display order of the pictures, i.e. Picture Order Count, POC;
- the decoding delay, defined as the PTS of the first displayed picture in a coded video sequence minus its DTS.

I.1.1 Closed Coded Video Sequence

In the case of a closed coded video sequence (see figure I.2) the first Dependent view component in decoding order shall be an MVC Stereo anchor view component associated with a Base view component containing an IDR picture. An anchor view component associated with an IDR base view component prohibits view component referencing over coded video sequence boundary, hence, it shall be possible to decode correctly all view components in a closed coded video sequence, even when random access to this coded video sequence is executed.

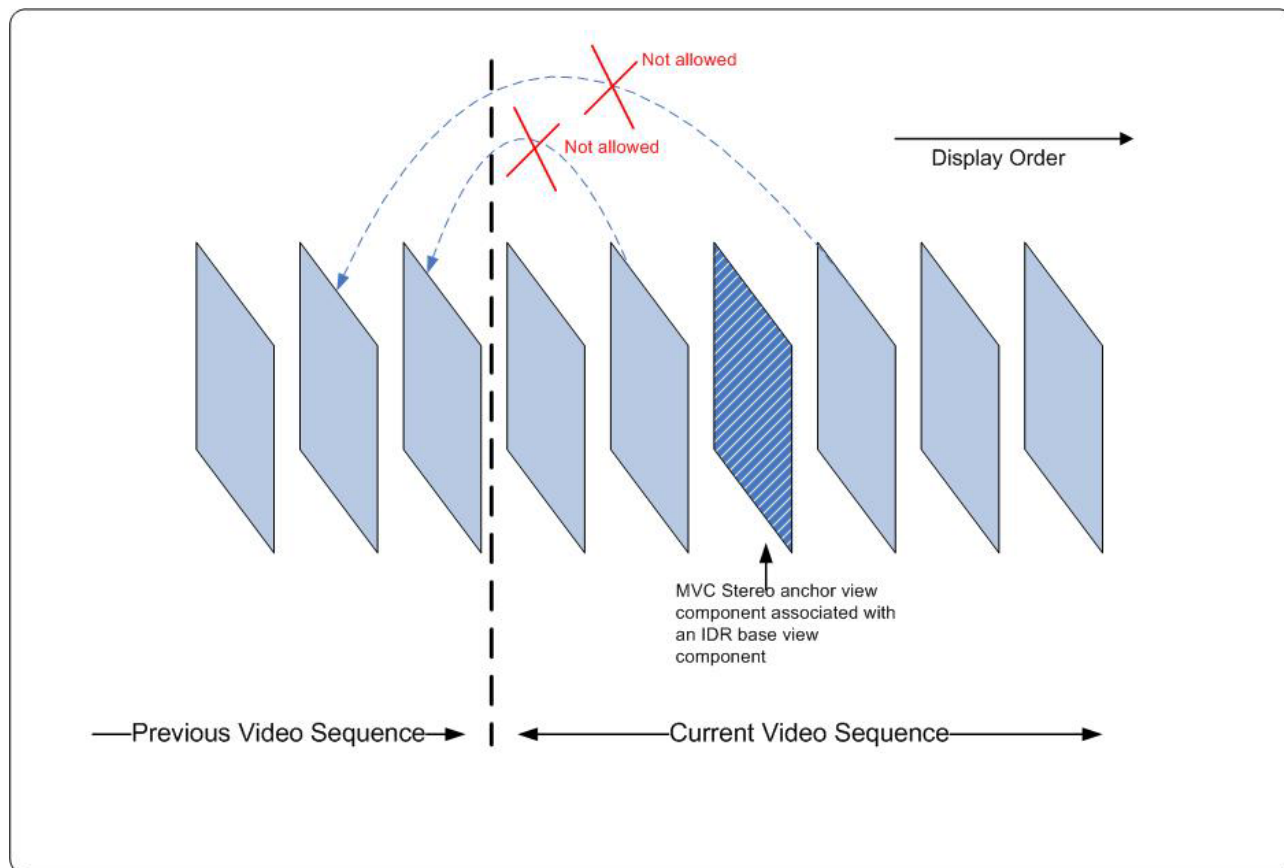

Figure I.2: Example of Closed coded video sequence for MVC Dependent view bitstream

I.1.2 Open Coded Video Sequence

In case of an open coded video sequence structure, (see figure I.3), the first Dependent view component in decoding order shall be an MVC Stereo anchor view component associated with a Base view component containing a (non-IDR) I picture. Since an anchor view component associated with a I picture does not prohibit view component referencing over coded video sequence boundary, it may be the case that view components prior to the I picture in display order cannot be correctly decoded when random access to this coded video sequence is executed.

If it is desirable to encode MVC sub-bitstream to correctly decode view components subsequent to the first Dependent anchor view component associated with a Base view component containing an I picture in display order, the following conditions shall be satisfied:

- Pictures prior to the first Dependent anchor view component associated with a Base view component containing an I picture in display order may use reference to past, future and Corresponding view components. It is assumed that these view components are not displayed in case of random access to an open coded video sequence.
- Pictures subsequent to the first Dependent anchor view component associated with a Base view component containing an I picture in display order may use references to past, future, and Corresponding view components, but these view components shall not use past reference to view components prior to the first anchor view components in display order.

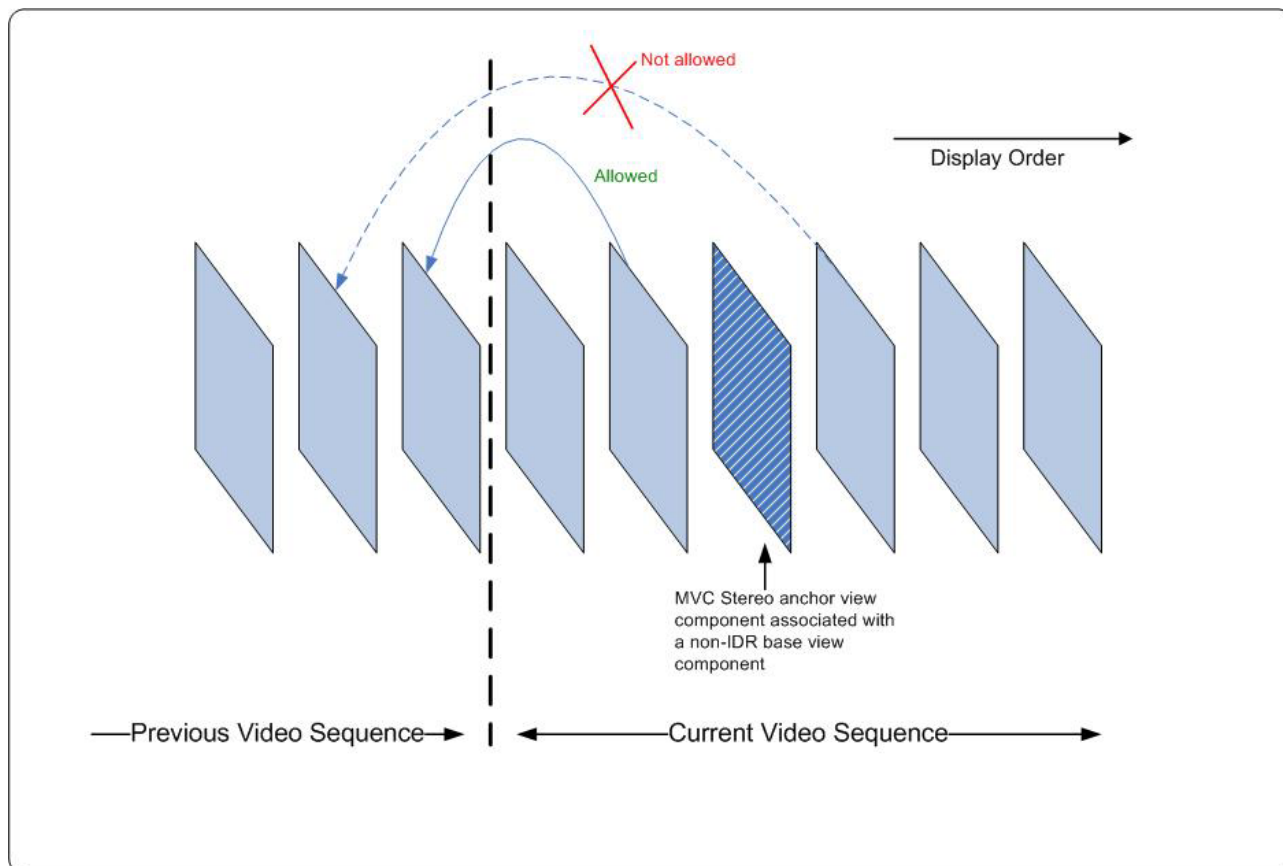

Figure I.3: Example of Open coded video sequence for MVC Dependent view bitstream

I.2 Guidelines for TS Packet Multiplexing

Re-multiplexing during transmission might alter the relative reception order of Base and Dependent transport stream packets (TS packets), when compared to the original transmission order. In this document, this is called 'inter-PID reordering'. Figure I.4 represents an sample setup of a live broadcast system where re-multiplexing of TS packets might cause inter-PID reordering.

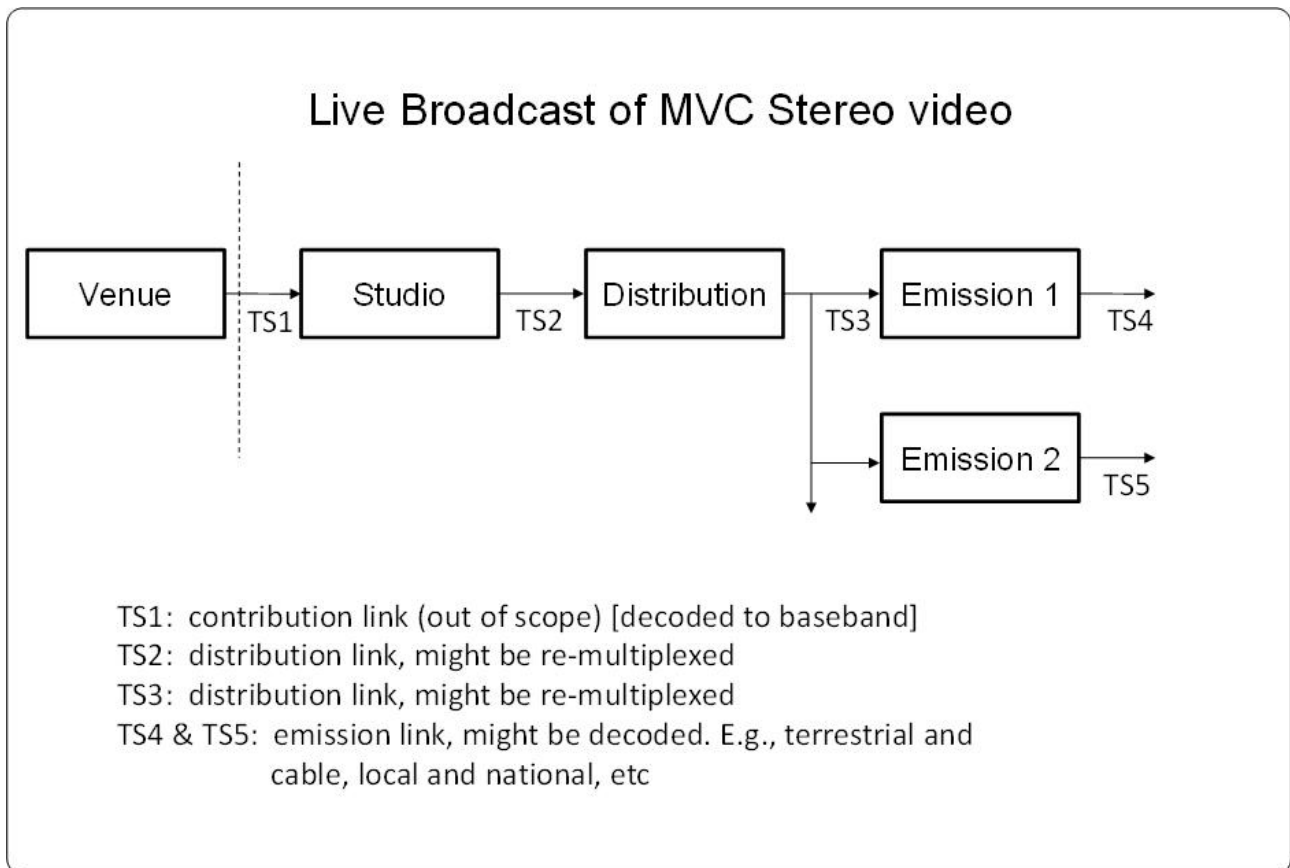

Figure I.4: Example of Live Broadcast where re-multiplexing might occur

Since the TS packet order affects random access, a transmission system should try to limit inter-PID re-ordering as much as possible. One possibility would be to satisfy the following conditions:

- The first transport packet of the PES packet header belonging to the MVC Stereo Base view component of the first Access Unit in a coded video sequence should precede the first transport packet of the PES packet header from the corresponding MVC Stereo Dependent view component.
- The last transport packet for the last Dependent Unit in the coded video sequence should precede the first transport packet of the PES packet header belonging to the MVC Stereo Base view component of the first Access Unit of the following coded video sequence.

Annex J (informative): Bibliography

- ETSI TR 101 162: "Digital broadcasting systems for television, sound and data services; Allocation of Service Information (SI) codes for Digital Video Broadcasting (DVB) systems".
- CEI/IEC 61883-1: "Consumer audio/video equipment - Digital interface - Part 1: General".
- CEI/IEC 61883-2: "Consumer audio/video equipment - Digital interface - Part 2: SD-SVCR data transmission".
- CEI/IEC 61883-3: "Consumer audio/video equipment - Digital interface - Part 3: HD-DVCR data transmission".
- CEI/IEC 61883-4: "Consumer audio/video equipment - Digital interface - Part 4: MPEG2-TS data transmission".
- IEC 62106:1999: "Radio Data System".
- ETSI ETR 154: "Digital Video Broadcasting (DVB); DVB implementation guidelines for the use of MPEG-2 Systems, Video and Audio in satellite and cable broadcasting applications".
- ETSI TR 102 154: "Digital Video Broadcasting (DVB); Implementation guidelines for the use of MPEG-2 Systems, Video and Audio in Contribution and Primary Distribution Applications".

History

Document history		
Edition 1	January 1996	Publication as ETR 154
Edition 2	October 1996	Publication as ETR 154
Edition 3	September 1997	Publication as ETR 154
V1.4.1	July 2000	Publication as TR 101 154
V1.5.1	May 2004	Publication
V1.6.1	January 2005	Publication
V1.7.1	June 2005	Publication
V1.8.1	July 2007	Publication
V1.9.1	September 2009	Publication
V1.10.1	June 2011	Publication
V1.11.1	November 2012	Publication