

ETSI TS 100 593 V7.0.0 (1999-08)

Technical Specification

**Digital cellular telecommunications system (Phase 2+);
Base Station Controller - Base Transceiver Station
(BSC - BTS) interface;
Interface principles
(GSM 08.52 version 7.0.0 Release 1998)**

The GSM logo consists of the letters 'GSM' in a bold, blue, sans-serif font. A small red square is positioned at the top right corner of the 'M'. A registered trademark symbol (®) is located to the right of the 'M'.

GSM®

GLOBAL SYSTEM FOR
MOBILE COMMUNICATIONS



Reference

RTS/SMG-030852Q7 (5ho03i03.PDF)

Keywords

Digital cellular telecommunications system,
Global System for Mobile communications (GSM)

ETSI

Postal address

F-06921 Sophia Antipolis Cedex - FRANCE

Office address

650 Route des Lucioles - Sophia Antipolis
Valbonne - FRANCE
Tel.: +33 4 92 94 42 00 Fax: +33 4 93 65 47 16
Siret N° 348 623 562 00017 - NAF 742 C
Association à but non lucratif enregistrée à la
Sous-Préfecture de Grasse (06) N° 7803/88

Internet

secretariat@etsi.fr
Individual copies of this ETSI deliverable
can be downloaded from
<http://www.etsi.org>
If you find errors in the present document, send your
comment to: editor@etsi.fr

Copyright Notification

No part may be reproduced except as authorized by written permission.
The copyright and the foregoing restriction extend to reproduction in all media.

© European Telecommunications Standards Institute 1999.
All rights reserved.

Contents

Intellectual Property Rights	4
Foreword	4
1 Introduction.....	4
1.1 Scope	4
1.2 References.....	5
2 Definitions and abbreviations	6
2.1 Base Station System, BSS.....	6
2.2 Base Station Controller, BSC	6
2.3 Base Transceiver Station, BTS	6
2.4 Cell.....	6
2.5 Transceiver, TRX	6
2.6 Base Control Function, BCF.....	6
3 General.....	7
4 Functional division between BSC and BTS	8
4.1 General.....	8
4.2 Terrestrial channel management	8
4.3 Radio channel management	8
4.3.1 Channel configuration management	8
4.3.2 SDCCCH (Stand alone DCCH) and TCH management	8
4.3.2.1 Frequency hopping management	8
4.3.2.2 Channel selection, link supervision and channel release	8
4.3.2.3 Power control.....	8
4.3.2.4 Idle channel observation.....	9
4.3.3 BCCH/CCCH management.....	9
4.3.4 Random access	9
4.3.5 Channel coding/decoding	9
4.3.6 Transcoding/rate adaption.....	9
4.3.7 Timing advance.....	9
4.3.8 Radio resource indication.....	9
4.3.9 Measurements.....	9
4.3.10 LAPDm functions (Layer 2).....	10
4.3.11 Paging.....	10
4.3.12 Handover.....	10
4.3.13 Encryption.....	10
4.3.14 Mobility management and call control.....	10
5 Transcoding/rate adaption and multiplexing	12
5.1 Transcoding/rate adaption in BTS	12
5.2 Transcoding/rate adaption outside BTS.....	13
6 Interface structures	13
6.1 Communication channels	13
6.2 Signalling links	14
6.3 Signalling model	15
Annex A (informative): Change Request History.....	18
History.....	19

Intellectual Property Rights

IPRs essential or potentially essential to the present document may have been declared to ETSI. The information pertaining to these essential IPRs, if any, is publicly available for **ETSI members and non-members**, and can be found in SR 000 314: "*Intellectual Property Rights (IPRs); Essential, or potentially Essential, IPRs notified to ETSI in respect of ETSI standards*", which is available **free of charge** from the ETSI Secretariat. Latest updates are available on the ETSI Web server (<http://www.etsi.org/ipr>).

Pursuant to the ETSI IPR Policy, no investigation, including IPR searches, has been carried out by ETSI. No guarantee can be given as to the existence of other IPRs not referenced in SR 000 314 (or the updates on the ETSI Web server) which are, or may be, or may become, essential to the present document.

Foreword

This Technical Specification (TS) has been produced by the Special Mobile Group (SMG).

The present document defines the interface principles of the Base Station Controller (BSS) to Base Transceiver Station (BTS) interface within the digital cellular telecommunications system (Phase 2/Phase 2+).

The contents of the present document is subject to continuing work within SMG and may change following formal SMG approval. Should SMG modify the contents of the present document it will be re-released with an identifying change of release date and an increase in version number as follows:

Version 7.x.y

where:

- 7 indicates Release 1998 of GSM Phase 2+
- x the second digit is incremented for all changes of substance, i.e. technical enhancements, corrections, updates, etc.
- y the third digit is incremented when editorial only changes have been incorporated in the specification.

1 Introduction

1.1 Scope

The use and general aspects of the A-bis interface are given in Technical Specification GSM 08.51.

The present document gives the principle basis for the rest of the specifications specifying the interface between the Base Station Controller, BSC, and the Base Transceiver Station, BTS, with its transceivers, TRX. These components together form the Base Station System, BSS. (The interface between MSC and the BSS is specified in Technical Specifications GSM 08.01 - 08.20).

The intention with this interface is to get a unified way of connecting remotely located BTSs/TRXs to a BSC allowing for the interconnection of BSCs and BTSs/TRXs from different manufacturers.

In order to keep the BTS as simple as possible, BTS contains only those functions which have to reside close to the radio interface.

1.2 References

The following documents contain provisions which, through reference in this text, constitute provisions of the present document.

- References are either specific (identified by date of publication, edition number, version number, etc.) or non-specific.
- For a specific reference, subsequent revisions do not apply.
- For a non-specific reference, the latest version applies.
- A non-specific reference to an ETS shall also be taken to refer to later versions published as an EN with the same number.
- For this Release 1998 document, references to GSM documents are for Release 1998 versions (version 7.x.y).

- [1] GSM 01.04: "Digital cellular telecommunications system (Phase 2+); Abbreviations and acronyms".
- [2] GSM 08.01: "Digital cellular telecommunications system (Phase 2+); Base Station System - Mobile services Switching Centre (BSS - MSC) interface General aspects".
- [3] GSM 08.02: "Digital cellular telecommunications system (Phase 2+); Base Station System - Mobile-services Switching Centre (BSS - MSC) interface Interface principles".
- [4] GSM 08.04: "Digital cellular telecommunications system (Phase 2+); Base Station System - Mobile-services Switching Centre (BSS - MSC) interface Layer 1 specification".
- [5] GSM 08.06: "Digital cellular telecommunications system (Phase 2+); Signalling transport mechanism specification for the Base Station System - Mobile-services Switching Centre (BSS - MSC) interface".
- [6] GSM 08.08: "Digital cellular telecommunications system (Phase 2+); Mobile Switching Centre - Base Station System (MSC - BSS) interface Layer 3 specification".
- [7] GSM 08.20: "Digital cellular telecommunications system (Phase 2+); Rate adaption on the Base Station System - Mobile-services Switching Centre (BSS - MSC) interface".
- [8] GSM 08.51: "Digital cellular telecommunications system (Phase 2+); Base Station Controller - Base Transceiver Station (BSC - BTS) interface General aspects".
- [9] GSM 08.58: "Digital cellular telecommunications system (Phase 2+); Base Station Controller - Base Transceiver Station (BSC - BTS) interface Layer 3 specification".
- [10] GSM 08.60: "Digital cellular telecommunications system (Phase 2+); Inband control of remote transcoders and rate adaptors".
- [11] GSM 08.61: "Digital cellular telecommunications system (Phase 2+); Inband control of remote transcoders and rate adaptors (half rate)".
- [12] GSM 12.21: "Digital cellular telecommunications system (Phase 2+); Network Management (NM) procedures and message on the A-bis interface".

2 Definitions and abbreviations

Abbreviations used in the present document are listed in GSM 01.04.

2.1 Base Station System, BSS

The system of base station equipment (transceivers, controllers, etc..) which is viewed by the MSC through a single interface as defined by the GSM 08 0x series of recommendations, as being the entity responsible for communicating with Mobile Stations in a certain area. The radio equipment of a BSS may cover one or more cells. A BSS may consist of one or more base stations. If an internal interface according to the GSM 08.5x series of recommendations is implemented, then the BSS shall consist of one Base Station Controller (BSC) and several Base Transceiver Stations (BTSS).

The functionality is described in Recommendation GSM 08.02.

2.2 Base Station Controller, BSC

A network component in the PLMN with the functions for control of one or more Base Transceiver Stations (BTSS).

2.3 Base Transceiver Station, BTS

A network component which serves one cell, and is controlled by a Base Station Controller. The BTS can consist of one or more TRXs with or without common control equipment.

2.4 Cell

See GSM 03.02.

2.5 Transceiver, TRX

The Transceiver, TRX, in the GSM PLMN is the functional entity which supports the 8 basic radio channels of the same TDMA-frame.

2.6 Base Control Function, BCF

A functional entity which handles common control functions within a BTS, e.g. frequency hopping sequences etc.

At a multi BTS site, one of the BCFs can also be chosen to perform functions common to the site (e.g. external alarms, power supply, time base).

3 General

Technical Specifications GSM 08.01 - 08.20 specify the functional split and interface between MSC and the Base Station System, BSS, the A- interface.

The BSS can be further subdivided into one BSC controlling one or more BTSs, each consisting of one or more TRXs. The interface treated by the present document is the interface between a BSC and a BTS. It is denoted the A-bis-interface.

The A-bis-interface is capable of supporting three different internal BTS configurations:

- one single TRX,
- a collection of TRXs where all are served by a common physical connection,
- a collection of TRXs, each served by its own physical connection.

Figure 3.1 shows some possible configurations.

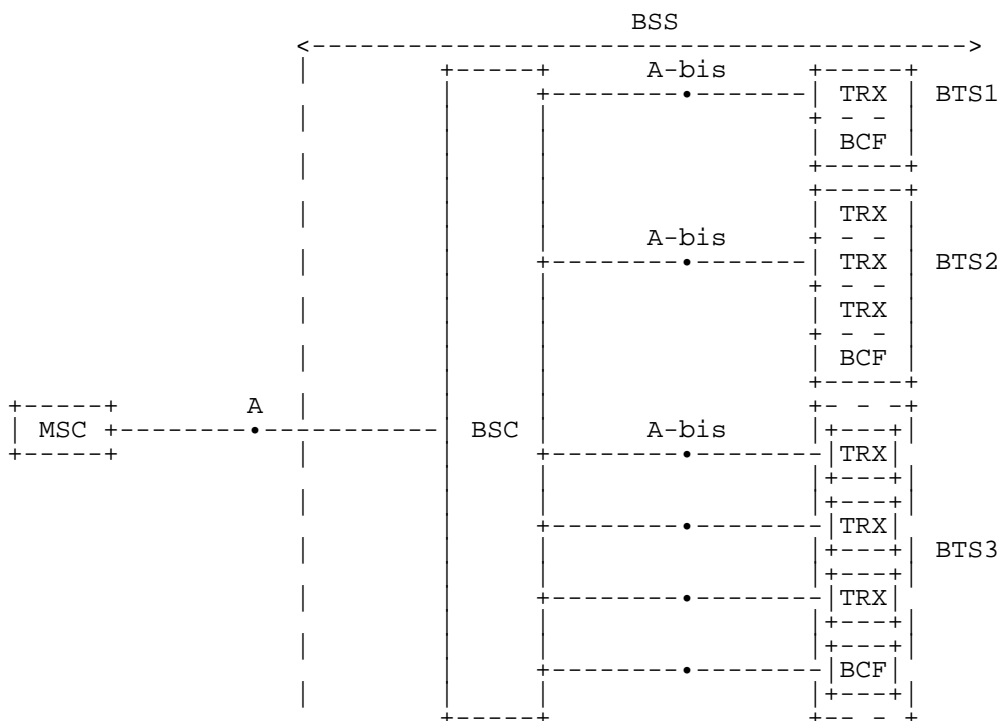

Figure 3.1/08.52: BSS Subdivision and Interfaces

The present document is based on the use of digital transmission system interfaces, either at 2048 kbit/s or at 64 kbit/s. Furthermore, the use of a subrate of 16 kbit/s and/or 8 kbit/s is supported for coded speech or rate adapted data.

This interface will support the transcoder positioned either inside or outside BTS. In the latter case, remote control (synchronisation) of the transcoder is used.

4 Functional division between BSC and BTS

4.1 General

In Technical Specification GSM 08.02 the functional division between MSC and BSS is described. This section describes the further subdivision of functions between BSC and BTS/TRX required for the A-bis interface. A summary can be found in table 4.1. Some general requirements on the functionality of the A-bis interface are also specified.

4.2 Terrestrial channel management

There is a unique mapping from traffic channels on the radio path to the terrestrial traffic channels. BSC makes the choice of radio channel and thereby also of the terrestrial channel for a call.

4.3 Radio channel management

4.3.1 Channel configuration management

The channel configuration is controlled between the BSC and OMC. Current configuration is downloaded from OMC to BSC which then controls the use of the radio channels (TDMA time slots for BCCH/CCCH, TCHs, SDCCHs etc).

4.3.2 SDCCH (Stand alone DCCH) and TCH management

4.3.2.1 Frequency hopping management

The hopping sequences for each BTS (cell) is downloaded from OMC to BSC. It is then the responsibility of BSC to download this information to each BTS and also to send the corresponding BCCH information to be transmitted in the BCCH time slots.

4.3.2.2 Channel selection, link supervision and channel release

These functions are controlled by BSC. For channel selection BSC has to have information on blocked radio channels and also on interference level on idle channels.

In the assignment messages to MS (Immediate Assign, Assign Command and Handover Command), a Starting Time parameter is included. This starting time is based on the frame number on the (new) BTS. Before sending the assign message to MS, BSC has to be informed on the current frame number in BTS.

When assigning a channel, BSC shall inform BTS on relevant parameters, e.g. channel type, channel coding, rate adaption, starting time.

4.3.2.3 Power control

The ordered MS power level is sent in the 16 bit L1-header of SACCH- blocks on the downlink and the actual power level used by MS is reported in the corresponding L1-header on the uplink. This header is inserted (downlink) and extracted (uplink) by BTS/TRX.

The determination of required power level in MS is based on uplink radio measurements made by BTS/TRX and reported to BSC. The basic control of this power is performed by BSC and the dynamic regulation is performed by BSC or optionally by BTS. If BTS supports dynamic MS power regulation, BSC can indicate whether BTS is to regulate the MS power and if so, also the parameters required by BTS.

The required TRX transmission power level on a channel is based on reported measurements performed by MS. The dynamic control of this power is optional. If supported, the basic control is performed by BSC and the dynamic regulation is performed by BSC or optionally by BTS. If BTS supports dynamic TRX transmission power regulation, BSC can indicate whether BTS is to regulate the transmission power and if so, also the parameters required by BTS.

4.3.2.4 Idle channel observation

Idle channels are monitored by BTS.

4.3.3 BCCH/CCCH management

TRX knows the timing of BCCH/CCCH slots (not known by BSC). The actual timing of BCCH/CCCH blocks therefore has to be made by BTS/TRX, including the scheduling of Paging Request messages on paging sub-channels.

BCCH information is downloaded to BTS.

4.3.4 Random access

Detection of a random access attempt has to be made by TRX which then sends a message to BSC containing the required timing advance, the frame number of the access attempt and the 8 bit Channel Request message sent by MS in the access burst. This information is then included by BSC in the following Immediate Assign message sent to MS.

4.3.5 Channel coding/decoding

The error protection coding and decoding is made by BTS/TRX.

Different coding and interleaving schemes are used for speech and data calls. This information has to be signalled from BSC to BTS on a per call basis.

4.3.6 Transcoding/rate adaption

The A-bis interface has to allow for the transcoder/rate adaptor being positioned either inside or outside BTS.

4.3.7 Timing advance

Timing advance has to be determined by TRX.

When MS is on a dedicated channel (SDCCH, TCH), the required timing advance (TA) is sent to MS and the actual timing advance is reported by MS in the 16 bit L1-header of the SACCH blocks.

At handover access, TA is determined by TRX and reported to MS in the PHYSical INFORMATION message sent by BTS/TRX.

At random access, TA is determined by TRX but in those cases, TA has to be reported to BSC for inclusion in the IMMEDIATE ASSIGN message sent to MS by BSC.

4.3.8 Radio resource indication

BTS reports on status (interference level, blocking etc.) of idle channels to BSC on a regular basis.

4.3.9 Measurements

MS measures the downlink received level and quality from the serving cell and the received level from surrounding cells. The results from these measurements are reported by MS in Measurement Report messages on SACCH.

Uplink received level and quality are measured by BTS/TRX. The parameters for the uplink measurements are equivalent to the parameters used by MS for the corresponding downlink measurements (averaging period and dynamic range).

The support of forwarding this basic raw measurement data over the A-bis interface is mandatory. Additionally, BTS and BSC may optionally support some pre-processing in BTS of this data.

4.3.10 LAPDm functions (Layer 2)

Layer 2 on the radio interface (LAPDm) is terminated at BTS/TRX. Between BTS and BSC, LAPD is used.

4.3.11 Paging

Paging is initiated by MSC via BSC.

BSC determines the paging group to be used based on IMSI of the MS to be paged. The paging group value is sent to BTS together with the TMSI or IMSI.

Based on the paging group information, BTS/TRX will build the relevant PAGING REQUEST message and execute the transmission of the message in the correct paging sub-channel.

4.3.12 Handover

No handover recognition or decision is made by BTS.

However, BTS/TRX has to detect the handover access made by a handed over MS. BTS/TRX also checks the Handover Reference value sent by MS in the handover access burst against the Handover Reference value received from BSC in the channel activation command. In case of an asynchronous handover, BTS/TRX then builds the PHYsical INFORMATION message (including the Timing Advance value) and sends it to MS. The handover access is also reported to BSC.

4.3.13 Encryption

Encryption and decryption is made of the complete outgoing bit stream (except for preambles/synch words). This therefore has to be made by TRX. The encryption key has to be downloaded to BTS/TRX before encryption starts. Special control messages are therefore required between BSC and BTS/TRX.

4.3.14 Mobility management and call control

All mobility management and call control functions reside in MSC.

TABLE 4.1: Summary of functional division between BTS and BSC/MSC

FUNCTION	LOCATION		
	BTS	BSC/MSC	
TERRESTRIAL CHANNEL MANAGEMENT			
MSC-BSC channels			
Channel allocation.....		X	
Blocking indication.....		X	
BSC-BTS channels			
Channel allocation.....		X	
Blocking indication.....	X		
RADIO CHANNEL MANAGEMENT			
Channel configuration management.....		X	
Frequency Hopping			
Management.....		X	
Execution.....	X		
TCH management			
Channel allocation (choice).....		X	
Link supervision.....		X	
Channel release.....		X	
Idle channel observation.....	X		
Power control determination.....	X	X	Note 3
SDCCH management (Stand alone DCCH)			
SDCCH allocation.....		X	
Link supervision.....		X	
Channel release.....		X	
Power control determination.....	X	X	Note 3
BCCH/CCCH management			
Scheduling of messages			
Management.....		X	
Execution.....	X		
Random access			
Access detection.....	X		
Immediate assign (access grant).....		X	
Channel coding/decoding.....	X		
Transcoding/rate adaption.....	X		Note 1
Measurements			
Uplink measuring.....	X		Note 2
Processing of reports from MS/TRX....	X	X	Note 4
Traffic measurements.....	X		

TABLE 4.1. (continued): Summary of functional division between BTS and BSC/MSC

	BTS	BSC/MSC
Timing advance		
Calculation.....X		
Signalling to MS at random access.....X		
Signalling to MS at handover.....X		
Signalling to MS during call.....X		
Radio resource indication		
Report status of idle channels.....X		
LAPDm functions (Layer 2).....X		
Encryption		
Management.....X		
Execution.....X		(Key from BSC)
Paging		
Initiation.....X		
DRX paging		
Management.....X		
Execution.....X		
Handover		
BSC internal, one cell.....X		
BSC internal, between cells.....X		
BSC external		
recognition, radio reason.....X		
recognition, traffic reason.....X		
decision.....X		
execution.....X		
Handover access detection.....X		
MOBILITY MANAGEMENT		
Authentication.....X		
Location updating.....X		
CALL CONTROL.....X		

NOTE 1: Although the transcoder is always controlled by the BTS, it can optionally be located outside the BTS (e.g. at the BSC or at the MSC site). In that case, remote control is performed by BTS using inchannel signalling.

NOTE 2: Including averaging comparable to what is done in the MS.

NOTE 3: The support of power level determination in BTS is optional.

NOTE 4: The support of forwarding all raw measurement data from MS/TRX over the A-bis interface and the processing of it in BSC is mandatory. The BTS/BSC may additionally support also some pre- processing in BTS of this raw data.

5 Transcoding/rate adaption and multiplexing

The interface supports two options: transcoding/rate adaption performed in BTS or outside BTS.

5.1 Transcoding/rate adaption in BTS

The transcoding of speech to normal 64 kbit/s A-law is performed within BTS.

Data may be rate adapted or submultiplexed to 64 kbit/s circuits.

5.2 Transcoding/rate adaption outside BTS

In this case the transcoder/rate adaptor is considered as part of the BSC.

The channel coding/decoding is performed by BTS/TRX. The choice of coding/interleaving has to be signalled from BSC to BTS.

The remote speech transcoder has to have knowledge of some radio parameters for an efficient decoding. In addition, the timing of the transcoder has to be aligned with the transmission of the frames over radio such that the frames from BSC arrive synchronized with the transmission over radio (minimizes delay due to remote transcoder). For this control and time alignment of the transcoder, inband signalling is used within a 16 kbit/s or an 8 kbit/s channel carrying speech or data, signalling and synchronisation. This remote control of the transcoder is specified in Technical Specifications GSM 08.60 (full rate traffic channels, 16 kbit/s submultiplexing only) and GSM 08.61 (half rate traffic channels, 16 or 8 kbit/s submultiplexing).

For data, rate adaption to subrate 16 or 8 kbit/s is performed within BTS.

For the link BTS-BSC, the following possibilities are foreseen:

- rate adaption of 16 kbit/s or 8 kbit/s speech + control or 16 kbit/s data + control to 64 kbit/s (one radio traffic channel per 64 kbit/s terrestrial channel),
- multiplexing of 16 kbit/s or 8 kbit/s speech + control or 16 kbit/s or 8 kbit/s data + control into one 64 kbit/s channel (up to eight radio traffic channels per 64 kbit/s terrestrial channel).

6 Interface structures

6.1 Communication channels

The A-bis interface is considered to have two types of communication channels (see figure 6.1):

- traffic channel (SDC) at 8, 16 or 64 kbit/s carrying speech or data of one radio traffic channel (Bm or Lm channel),
- signalling channels (SCH) at 16, 32 or 64 kbit/s, carrying signalling information (both BSC-MS and BSC-BTS signalling).

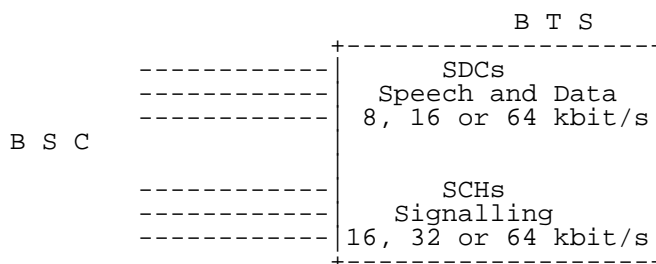

Figure 6.1/08.52: Communication Channel Types

6.2 Signalling links

The addressing of TRXs and BCF is made using separate TEIs for each TRX and BCF.

Three logical links are defined for each TEI:

RSL: Radio Signalling Link used for supporting traffic management procedures (MS to network communication). One link per TRX.

OML: Operations and Maintenance Link used for supporting network management procedures (transferring operations and maintenance messages). One link per TRX and BCF.

L2ML: Layer 2 Management Link used for transferring layer 2 management messages to TRX or BCF. One link per TRX and BCF.

A logical diagram for the architecture of the signalling links is given in figure 6.2/08.52.

Only point to point signalling links are used.

SMS messages are also carried on the signalling links.

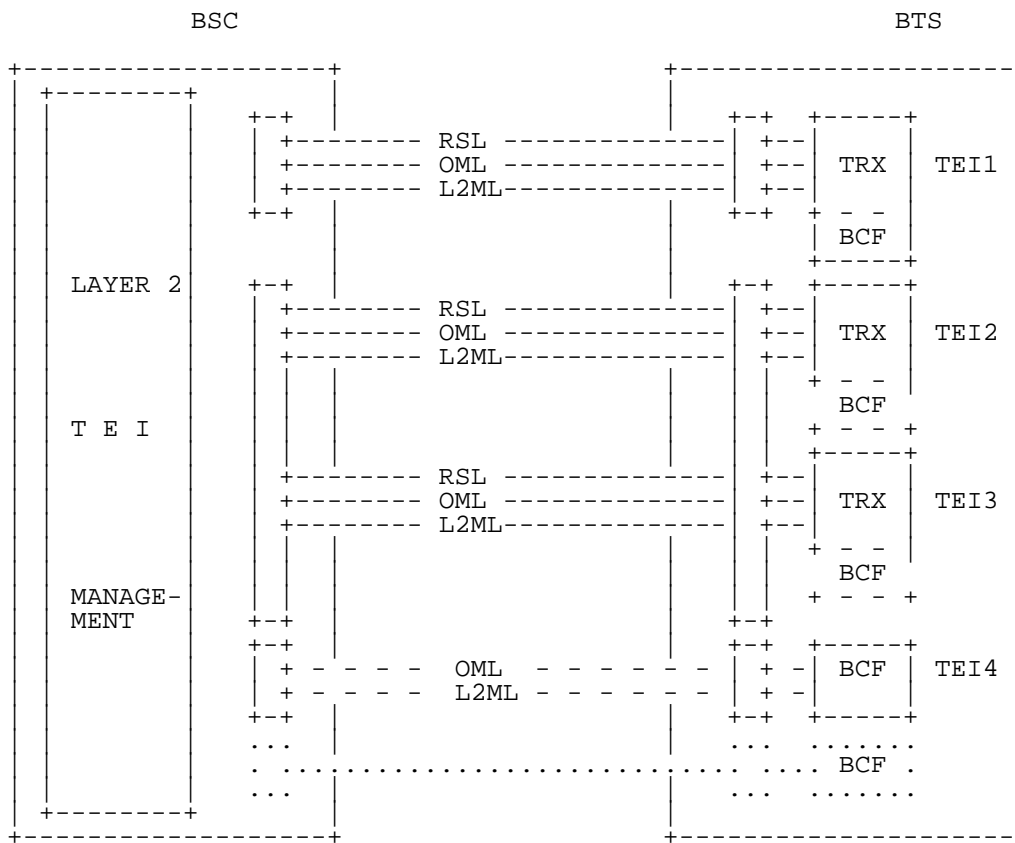

Figure 6.2/08.52: Logical L2 links of A-bis interface

6.3 Signalling model

A signalling model for the A-bis interface and its signalling environment can be found in figure 6.3.

CM and MM messages are not interpreted by BSC or BTS. Over the A interface they are transferred using DTAP (Direct Transfer Application Part) and over the A-bis interface they are transferred as transparent messages.

RR messages are mapped to BSSAP (BSS Application Part) in BSC. In BTS, most of them are handled as transparent messages. However, some of them have to be interpreted by BTS (e.g. random access, start ciphering, paging). The BTSM (BTS Management) entities contain procedures for handling these messages and also other procedures for managing the BTS as defined in Technical Specification GSM 08.58. In BTS there is a mapping between BTSM and the relevant RR messages over the radio interface (RR').

The Layer 2 protocol over the A-bis interface is based on LAPD. L2 addressing is made to TRX (or BCF) using the TEI of LAPD. Different L2 links are used for traffic management messages (RSL, Radio Signalling Link), network management messages (OML, Operation & Maintenance Link) and L2 management messages (L2ML, Layer 2 Management Link).

A model of Layer 3 for the A-bis interface can be found in figure 6.4.

For traffic management, two types of signalling messages have been defined:

Transparent Messages: Messages which are forwarded by BTS without interpretation or changes.

Non-Transparent Messages: Messages which are sent only between BSC and BTS and which BTS is acting upon or which are the results of BTS actions.

In addition, the messages have been grouped into four main groups: Radio Link Layer Management, Dedicated Channel Management, Common Channel Management and TRX Management messages.

Discrimination between these types and groups is based on the Message Discriminator which is sent as the first octet in all messages. Transparent and non-transparent messages are discriminated by a transparency flag (T-bit) in the Message Discriminator. Transparent messages are merely forwarded to L2 on the radio interface.

In order to address the relevant radio channel, a Channel Number element is included to support the distribution of messages to relevant physical channels on the TRX. A Link Identifier element supports the distribution on logical links/channels on the radio interface (compare the DLCI element of the A interface, GSM 08.06).

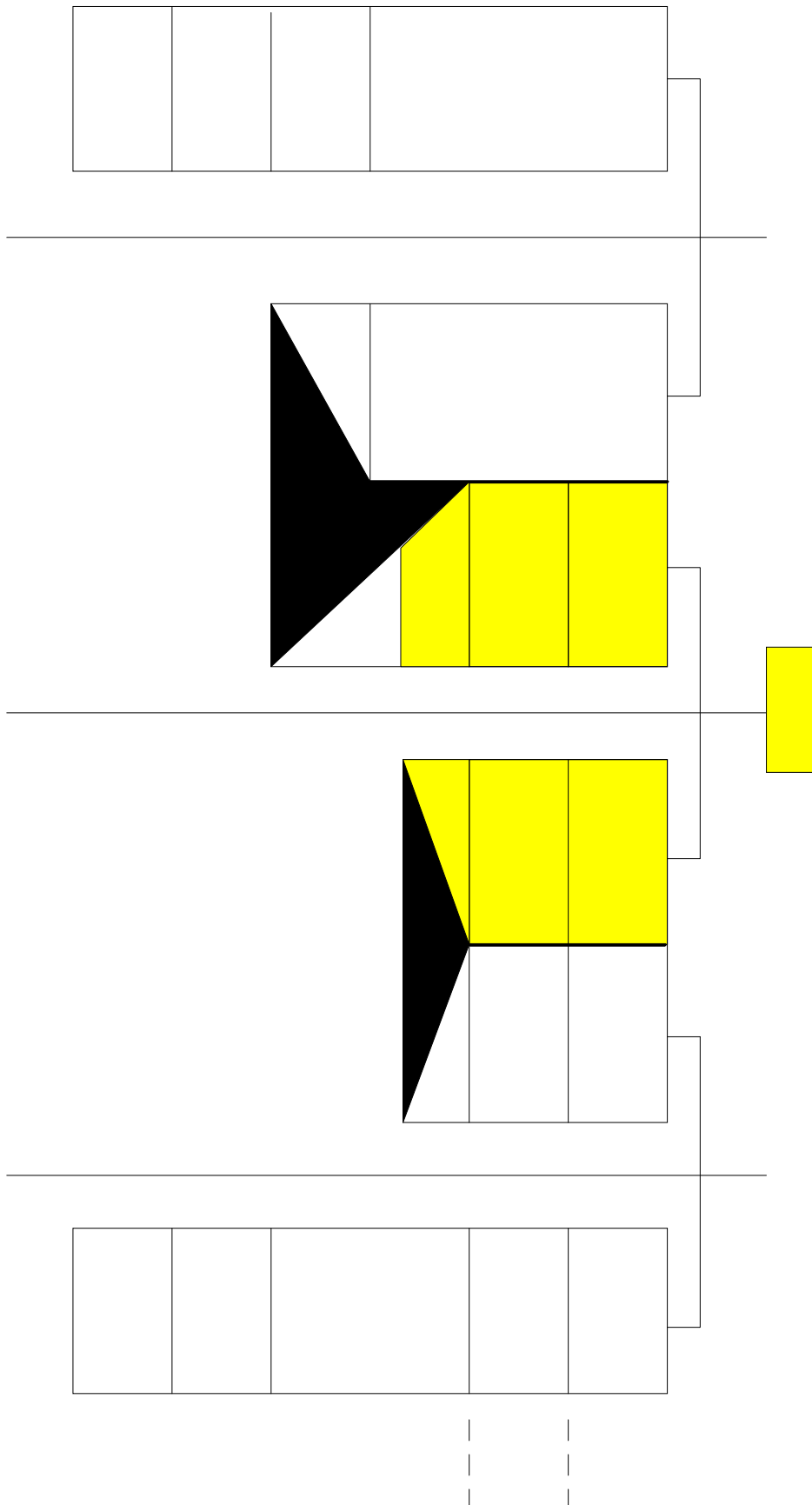

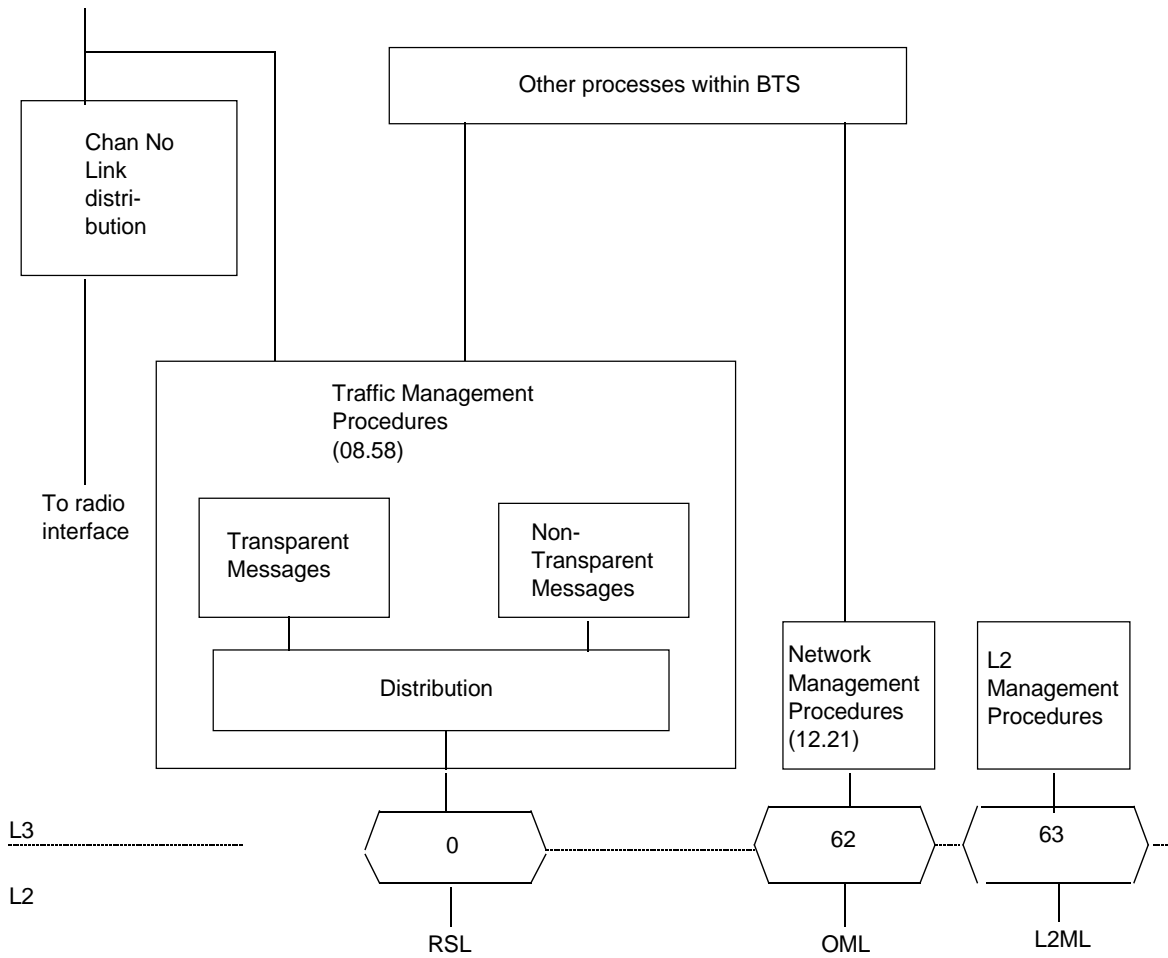

Figure 6.4/08.52: L3 model

Annex A (informative): Change Request History

Change history					
SMG No.	TDoc. No.	CR. No.	Section affected	New version	Subject/Comments
SMG#07				4.0.4	ETSI Publication
SMG#13				4.1.0	ETSI Publication
SMG#15				4.2.0	ETSI Publication
SMG#20				5.0.0	Release 1996 version
SMG#27				6.0.0	Release 1997 version
SMG#29				7.0.0	Release 1998 version

History

Document history		
V7.0.0	August 1999	Publication