

ETSI TS 100 394-1 V2.1.1 (2000-09)

Technical Specification

Terrestrial Trunked Radio (TETRA); Conformance testing specification; Part 1: Radio

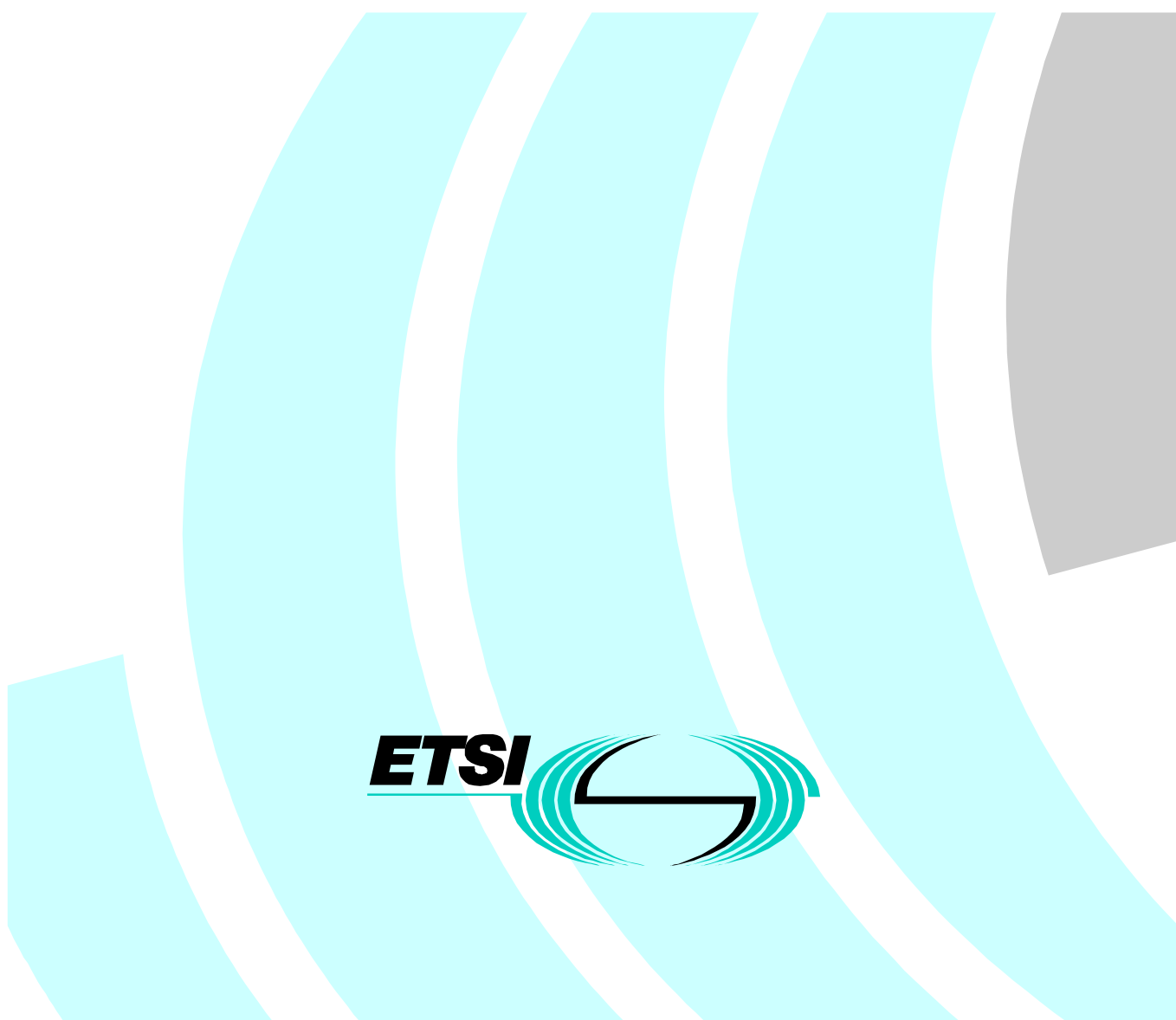

Reference

DTS/TETRA-02022-1

Keywords

TETRA

ETSI

650 Route des Lucioles
F-06921 Sophia Antipolis Cedex - FRANCE

Tel.: +33 4 92 94 42 00 Fax: +33 4 93 65 47 16

Siret N° 348 623 562 00017 - NAF 742 C
Association à but non lucratif enregistrée à la
Sous-Préfecture de Grasse (06) N° 7803/88

Important notice

Individual copies of the present document can be downloaded from:

<http://www.etsi.org>

The present document may be made available in more than one electronic version or in print. In any case of existing or perceived difference in contents between such versions, the reference version is the Portable Document Format (PDF). In case of dispute, the reference shall be the printing on ETSI printers of the PDF version kept on a specific network drive within ETSI Secretariat.

Users of the present document should be aware that the document may be subject to revision or change of status. Information on the current status of this and other ETSI documents is available at <http://www.etsi.org/tb/status/>

If you find errors in the present document, send your comment to:
editor@etsi.fr

Copyright Notification

No part may be reproduced except as authorized by written permission.
The copyright and the foregoing restriction extend to reproduction in all media.

© European Telecommunications Standards Institute 2000.
All rights reserved.

Contents

Intellectual Property Rights	9
Foreword.....	9
1 Scope	10
2 References	10
3 Definitions, symbols and abbreviations	11
3.1 Definitions	11
3.2 Symbols.....	11
3.3 Abbreviations	12
4 General	12
4.1 Presentation of equipment for testing purposes.....	12
4.1.1 Facilities and information required for testing	12
4.1.2 Choice of radio frequency channels to be tested.....	13
4.1.3 Interpretation of the measurement results	13
4.2 Mechanical and electrical design.....	13
4.2.1 General.....	13
4.2.2 Controls	14
4.2.3 Marking	14
5 Radio test configuration, test signals and test modes	14
5.1 General functional radio test configuration	14
5.2 Radio test modes	15
5.2.1 Test receive mode	15
5.2.1.1 MS test receive mode	15
5.2.1.2 BS test receive mode.....	15
5.2.2 Test transmit mode.....	16
5.2.2.1 MS V+D testing	16
5.2.2.2 MS PDO testing	16
5.2.2.3 BS V+D & PDO testing	17
5.3 Radio test signals.....	17
5.3.1 General.....	17
5.3.2 Test signal T1 (TETRA wanted signal)	17
5.3.2.1 MS V+D testing	17
5.3.2.2 BS V+D testing	18
5.3.2.3 MS PDO testing	19
5.3.2.4 BS PDO testing	19
5.3.3 Test signal T2 (TETRA interferer)	19
5.3.4 Test signal T3 (unmodulated interferer)	20
6 Test conditions	20
6.1 General	20
6.2 Power sources and ambient conditions.....	20
6.2.1 Normal test conditions	20
6.2.2 Extreme test conditions.....	20
6.3 Procedure for tests at extreme temperatures.....	21
6.3.1 Equipment designed for continuous operation.....	21
6.3.2 Equipment designed for intermittent operation.....	22
7 Technical characteristics	22
7.1 Transmitter parameter definitions & limits	22
7.1.1 Transmitter output power.....	22
7.1.1.1 Definition	22
7.1.1.2 Limit values.....	22
7.1.2 Unwanted output power in non-active transmit state.....	23
7.1.2.1 Definition	23
7.1.2.2 Limit values.....	23

7.1.3	Adjacent channel power due to modulation.....	23
7.1.3.1	Definition	23
7.1.3.2	Limit values.....	23
7.1.4	Adjacent channel power due to switching transients	23
7.1.4.1	Definition	23
7.1.4.2	Limit values.....	23
7.1.5	Unwanted emissions far from the carrier	24
7.1.5.1	Definition	24
7.1.5.2	Limit values.....	24
7.1.6	Unwanted radiated emissions	24
7.1.6.1	Definition	24
7.1.6.2	Limit values.....	24
7.1.7	Unwanted emissions during the BLCH/CLCH (linearization)	25
7.1.7.1	Definition	25
7.1.7.2	Limit values.....	25
7.1.8	Transmitter intermodulation attenuation.....	25
7.1.8.1	Definition	25
7.1.8.2	Limit values.....	25
7.1.8.2.1	MS Limit values	25
7.1.8.2.2	Limit values for single BS transmitter	25
7.1.8.2.3	Limit values for Intra BS intermodulation.....	25
7.2	Receiver parameter definitions and limits	26
7.2.1	General.....	26
7.2.2	Nominal error rates	26
7.2.2.1	Definition	26
7.2.2.2	Limit values.....	26
7.2.3	Reference sensitivity performance.....	27
7.2.3.1	Definition	27
7.2.3.2	Limit values.....	27
7.2.4	Reference interference performance	27
7.2.4.1	Definition	27
7.2.4.2	Limit values.....	27
7.2.5	Blocking characteristics	28
7.2.5.1	Definition	28
7.2.5.2	Limit values.....	28
7.2.6	Spurious response rejection	28
7.2.6.1	Definition	28
7.2.6.2	Limit values.....	28
7.2.7	Intermodulation response rejection.....	29
7.2.7.1	Definition	29
7.2.7.2	Limit values.....	29
7.2.8	Unwanted conducted emissions.....	29
7.2.8.1	Definition	29
7.2.8.2	Limit values.....	29
7.2.9	Unwanted radiated emissions	29
7.2.9.1	Definition	29
7.2.9.2	Limit values.....	29
7.3	Transmitter/receiver parameter definitions & limits	30
7.3.1	Modulation accuracy.....	30
7.3.1.1	Definition	30
7.3.1.2	Limit values.....	30
7.3.2	Carrier frequency accuracy	30
7.3.2.1	Definition	30
7.3.2.2	Limit values.....	30
7.3.3	MS receiver performance for synchronization burst acquisition	30
7.3.3.1	Definition	30
7.3.3.2	Limit values.....	30
7.3.4	MS Frame alignment performance	31
7.3.4.1	Definition	31
7.3.4.2	Limit values.....	31
7.3.5	MS link control	31
7.3.5.1	Definition	31

7.3.5.2	Limit values.....	31
8	Methods of measurement for transmitter parameters	32
8.1	Transmitter output power	32
8.1.1	MS transmitter output power	32
8.1.2	BS transmitter output power	33
8.2	Unwanted output power in non active transmit state.....	33
8.3	Adjacent channel power due to modulation	34
8.4	Adjacent channel power due to switching transients.....	34
8.5	Unwanted emissions far from the carrier	34
8.6	Unwanted radiated emissions	35
8.7	Unwanted emissions during the BLCH/CLCH (linearization).....	36
8.7.1	MS unwanted emissions during the CLCH (linearization)	36
8.7.2	BS unwanted emissions during the BLCH (linearization)	36
8.8	Transmitter intermodulation attenuation	36
8.8.1	MS Transmitter intermodulation attenuation	37
8.8.2	BS Transmitter intermodulation attenuation.....	37
8.8.3	Intra BS transmitter intermodulation attenuation.....	37
9	Methods of measurement for receiver parameters	37
9.1	General	37
9.2	Nominal error rates.....	37
9.2.1	MS nominal error rate.....	37
9.2.2	BS nominal error rate.....	37
9.3	Reference sensitivity performance	38
9.3.1	MS reference sensitivity performance	38
9.3.2	BS reference sensitivity performance	38
9.3.3	PUEM performance	38
9.4	Reference interference performance.....	39
9.4.1	MS reference interference performance.....	39
9.4.2	BS reference interference performance.....	39
9.5	Blocking characteristics	39
9.5.1	MS blocking.....	40
9.5.2	BS blocking	40
9.6	Spurious response rejection	40
9.7	Intermodulation response rejection	40
9.7.1	MS intermodulation response rejection	40
9.7.2	BS intermodulation response rejection	41
9.8	Unwanted emissions.....	41
9.9	Unwanted radiated emissions	41
10	Methods of measurement for transmitter/receiver parameters	42
10.1	Modulation accuracy	42
10.1.1	MS modulation accuracy	42
10.1.2	BS modulation accuracy	42
10.1.3	Vector error magnitude at symbol time	42
10.2	Carrier frequency accuracy.....	42
10.2.1	MS carrier frequency accuracy	43
10.2.2	BS carrier frequency accuracy	43
10.3	MS receiver performance for synchronization burst acquisition.....	43
10.4	MS Frame alignment performance	44
10.5	MS link control.....	44
11	Measurement uncertainty	45
11.1	Transmitter	46
11.2	Receiver.....	49
11.3	Transmitter/receiver parameter definitions & limits	51
11.4	Interpretation of measurement results	51

Annex A (normative):	TETRA receiver testing.....	52
A.1	Frequencies of spurious response.....	52
A.2	Test cases and test conditions for BS and MS receivers	53
A.3	Test signal T1, content of BSCH and BNCH/T (V+D) & MBCH/T (PDO).....	59
Annex B (normative):	Radio test system functions.....	61
B.1	Test transmitter and receiver	61
B.1.1	General	61
B.1.2	Sampling system	61
B.1.2.1	General.....	61
B.1.2.2	TETRA filter.....	61
B.1.2.3	Adjacent channel power measurements.....	61
B.1.2.4	Modulation accuracy measurements.....	62
B.1.2.5	Measurement of unwanted output power in the non-active transmit state.....	62
B.1.3	Spectrum analyser	62
B.1.4	Error rate tester.....	62
B.1.5	Test signal requirements.....	62
B.1.5.1	On channel test signal T1.....	62
B.1.5.2	Interfering test signal T2.....	63
B.1.5.3	Interfering test signal T3.....	63
B.1.6	Propagation simulators	63
B.1.7	Timing measurement unit.....	63
B.1.8	Passive test system components	64
B.1.9	Test system controller	64
Annex C (normative):	TETRA Test Connector Interface (TTCI)	65
C.1	General	65
C.2	Formal aspects.....	65
C.3	TTCI, layer 1	66
C.3.1	Mechanical and Electrical Characteristics.....	66
C.3.2	Transmission and Reception Characteristics	66
C.4	TTCI, Layer 2.....	66
C.4.1	General Structure.....	66
C.4.2	Frame Structure	66
C.4.3	Flow of I-frames on Layer 2.....	67
C.4.3.1	Transmission of Frames	67
C.4.3.2	Reception of frames	67
C.4.3.3	Parameters on Layer 2	68
C.5	TTCI, Layer 3.....	68
C.5.1	Message structure	68
C.5.2	Definitions of the Messages	68
C.5.2.1	DATO	68
C.5.2.1.1	Test equipment error handling	69
C.5.2.2	Bi-directional operation of the TTCI	70
C.5.2.3	Codec conformance testing.....	71
C.5.2.4	ST indicator	71
C.6	Control of MS/BS.....	71
C.6.1	Manual intervention of MS/BS	71
C.6.2	Bi-directional operation of the test interface	71
C.6.3	MS controlled by T1.....	71
C.7	Characteristics of the interface	71
C.7.1	Mechanical characteristics of the interface.....	71
C.7.2	Electric characteristics of the interface.....	72

C.8	Codec conformance testing using the TTCI.....	72
C.8.1	Codec conformance test methodology using the TTCI.....	72
Annex D (normative): RF Test Facility using RF Loop Back.....		74
D.1	Introduction to the TETRA Test (TT) protocol for RF loop back test.....	76
D.1.1	Outline requirements.....	76
D.1.2	Test Modes.....	76
D.1.3	Switching for loop back test mode.....	76
D.2	TETRA Test Entity.....	78
D.3	TETRA RF loop back test protocol.....	79
D.3.1	Setting the TETRA MS into TETRA Test mode.....	79
D.3.2	TETRA TEST protocol.....	79
D.3.2.1	Confirming that TETRA TEST MODE is set.....	79
D.3.2.2	Operating TETRA loop back.....	80
D.3.2.3	Ending TETRA Test mode.....	81
D.3.3	Bad frame indication.....	81
D.3.4	Channels required to be looped back.....	81
D.3.5	TETRA loop back test scenarios.....	81
D.4	TETRA Test (TT) PDU descriptions.....	82
D.4.1	TT PDU description tables downlink.....	82
D.4.1.1	D-LOOP COMMAND.....	82
D.4.1.2	D-OPEN LOOP COMMAND.....	82
D.4.1.3	D-TEST MODE CONFIRM COMMAND.....	83
D.4.1.4	D-TEST MODE END COMMAND.....	83
D.4.2	TT PDU description tables uplink.....	83
D.4.2.1	U-LOOP CONFIRM.....	83
D.4.2.2	U-OPEN LOOP CONFIRM.....	84
D.4.2.3	U-TEST MODE CONFIRM.....	84
D.4.2.4	U-TEST MODE END CONFIRM.....	85
D.4.3	Information elements coding.....	85
D.4.3.1	Loopback type.....	85
D.4.3.2	Confirm.....	85
D.4.3.3	MS power class.....	86
D.4.3.4	PDU.....	86
D.4.3.5	Receiver class.....	86
D.5	TT use of MLE, LLC and MAC.....	87
D.6	Message sequence charts and operation of TETRA loop back.....	87
D.7	Introduction to the T1 Test Mode for RF loop back test.....	88
D.7.1	Outline requirements.....	88
D.7.2	T1 Test Modes.....	88
D.7.3	Switching for loop back test mode.....	88
D.8	TETRA RF loop back T1 test mode.....	90
D.8.1	Setting TETRA equipment into T1 test mode.....	90
D.8.2	T1 loop back test mode operation.....	90
D.8.3	Logical channels to be looped back.....	91
D.8.4	Return channel for logical channel loop back.....	91
D.8.4.1	Type 1: TCH/7,2 + AACH.....	92
D.8.4.2	Type 2: SCH/F + AACH.....	92
D.8.4.3	Type 3: BSCH + SCH/HD + AACH.....	93
D.8.4.4	Type 4: TCH/2,4 N = 1 + AACH.....	93
D.8.4.5	Type 7: TCH/7,2 (uplink).....	93
D.8.4.6	Type 8: SCH/F (uplink).....	93
D.8.4.7	Type 9: STCH + STCH (uplink).....	94
D.8.4.8	Type 10: TCH/2,4 N = 1 (uplink).....	94
D.8.4.9	Type 11: SCH/HU + SCH/HU.....	94
D.8.4.10	Type 15: TCH/S + TCH/S + AACH.....	94
D.8.4.11	Type 16: TCH/S + TCH/S (uplink).....	95

D.8.4.12	Type 17: TCH/4,8 N = 1 + AACH	95
D.8.4.13	Type 18: TCH/4,8 N = 1 (uplink)	95
D.8.4.14	Type 19: TCH/S speech codec test (downlink).....	95
D.8.4.15	Type 20: TCH/S speech codec test (uplink)	96
D.8.5	Loop back test scenarios.....	96
D.9	Direct Mode Operation (DMO).....	97
D.9.1	DO-MS	97
D.9.2	DU-MS	97
D.9.3	DW-MS	98
D.9.4	DM-REP.....	98
D.9.5	DM-GATE	98
D.9.6	DM-REP/GATE.....	98
D.9.7	DMO summary.....	98
Annex E (informative): Using RF loop back to test a TETRA MS.....		99
E.1	Introduction	99
E.2	Expected mode of operation for testing a MS	100
E.3	Recognition of TETRA Test mode by MS.....	103
E.4	Using loop back to test traffic channels	104
E.4.1	TCH/7,2.....	108
E.4.2	TCH/S	108
E.4.3	TCH/2,4, N = 8.....	109
E.4.4	Control messages during loop back of traffic channels	109
Annex F (normative): Direct Mode (DMO) Conformance Testing.....		110
F.1	Scope	110
F.2	Definitions, symbols and abbreviations	110
F.3	General	110
F.4	Radio Test Modes.....	111
F.5	Test Conditions	112
F.6	Additional Tests for equipment which is capable of Direct Mode Operation.....	113
F.6.1	DMO Test transmit mode.....	113
F.6.2	DMO transmitter output power profile.....	113
F.6.2.1	DMO transmitter output power profile, limit values	113
F.6.2.2	DMO transmitter output power profile, method of measurement.....	113
F.6.3	DMO Carrier frequency accuracy	114
F.6.3.1	DMO Carrier frequency accuracy, limit values	114
F.6.3.2	DMO Carrier frequency accuracy, method of measurement	114
F.6.4	DM-MS Slave synchronization accuracy	114
F.6.4.1	DM-MS Slave synchronization accuracy, definition	114
F.6.4.2	DM-MS Slave synchronization accuracy, limit values	114
F.6.4.3	DM-MS Slave synchronization accuracy, method of measurement	115
Annex G (normative): TETRA EMC requirements related to the antenna port and emissions from the enclosure of the radio equipment		116
History		117

Intellectual Property Rights

IPRs essential or potentially essential to the present document may have been declared to ETSI. The information pertaining to these essential IPRs, if any, is publicly available for **ETSI members and non-members**, and can be found in ETSI SR 000 314: "*Intellectual Property Rights (IPRs); Essential, or potentially Essential, IPRs notified to ETSI in respect of ETSI standards*", which is available from the ETSI Secretariat. Latest updates are available on the ETSI Web server (<http://www.etsi.org/ipr>).

Pursuant to the ETSI IPR Policy, no investigation, including IPR searches, has been carried out by ETSI. No guarantee can be given as to the existence of other IPRs not referenced in ETSI SR 000 314 (or the updates on the ETSI Web server) which are, or may be, or may become, essential to the present document.

Foreword

This Technical Specification (TS) has been produced by ETSI Project Terrestrial Trunked Radio (TETRA).

The present document contains text concerning conformance testing of the equipment to which it relates. This text should be considered only as guidance and does not make the present document mandatory.

The technical specifications relevant to the EMC Directive are listed in annex G of the present document.

The present document is part 1 of a multi-part deliverable covering the conformance testing specification, as identified below:

- Part 1: **"Radio"**;
- Part 2: "Protocol testing specification for Voice plus Data (V+D)";
- Part 3: "Protocol testing specification for Packet Data Optimized (PDO)";
- Part 4: "Protocol testing specification for Direct Mode Operation (DMO)";
- Part 5: "Security".

1 Scope

The present document specifies the minimum technical characteristics of both TETRA Voice plus Data (V+D) and Packet Data Optimized (PDO) Base Stations (BS) and Mobile Station (MS) equipment, and TETRA Direct Mode Operation (DMO) equipment, and the radio test methods used for type testing. Specific test methods for DMO equipment are defined in annex F of the present document. The purpose of these specifications is to provide a sufficient quality of radio transmission and reception for equipment operating in a TETRA system and to minimize harmful interference to other equipment. The document is applicable to TETRA systems operating at radio frequencies in the range of 300 MHz to 1 GHz.

These specifications do not necessarily include all the characteristics which may be required by a user of equipment, nor do they necessarily represent the optimum performance achievable.

2 References

The following documents contain provisions which, through reference in this text, constitute provisions of the present document.

- References are either specific (identified by date of publication, edition number, version number, etc.) or non-specific.
- For a specific reference, subsequent revisions do not apply.
- For a non-specific reference, the latest version applies.

- [1] ETSI EN 300 392-2: "Terrestrial Trunked Radio (TETRA); Voice plus Data (V+D); Part 2: Air Interface (AI)".
- [2] ETSI ETS 300 393-2: "Terrestrial Trunked Radio (TETRA); Packet Data Optimized (PDO); Part 2: Air Interface (AI)".
- [3] ITU-T Recommendation O.153 (1992): "Basic parameters for the measurement of error performance at bit rates below the primary rate".
- [4] ETSI ETR 028: "Radio Equipment and Systems (RES); Uncertainties in the measurement of mobile radio equipment characteristics".
- [5] ETSI ETS 300 113: "Radio Equipment and Systems (RES); Land mobile service; Technical characteristics and test conditions for radio equipment intended for the transmission of data (and speech) and having an antenna connector".
- [6] CCITT Recommendation V.1 (1988): "Equivalence between binary notation symbols and the significant conditions of a two-condition code".
- [7] ISO 2110 (1989): "Information technology - Data communication - 25-pole DTE/DCE interface connector and contact number assignments".
- [8] ETSI ETS 300 395-4: "Terrestrial Trunked Radio (TETRA); Speech codec for full-rate traffic channel; Part 4: Codec conformance testing".
- [9] ETSI ETS 300 396-1: "Terrestrial Trunked Radio (TETRA); Technical requirements for Direct Mode Operation (DMO); Part 1: General network design".
- [10] ETSI ETS 300 396-2: "Terrestrial Trunked Radio (TETRA); Technical requirements for Direct Mode Operation (DMO); Part 2: Radio aspects".
- [11] ETSI ETS 300 396-3: "Terrestrial Trunked Radio (TETRA); Technical requirements for Direct Mode Operation (DMO); Part 3: Mobile Station to Mobile Station (MS-MS) Air Interface (AI) protocol".

- [12] ETSI ETS 300 392-1: "Terrestrial Trunked Radio (TETRA); Voice plus Data (V+D); Part 1: General Network Design".
- [13] ETSI EN 300 392-7: "Terrestrial Trunked Radio (TETRA); Voice plus Data (V+D); Part 7: Security".
- [14] ETSI ETS 300 392-11-22: "Terrestrial Trunked Radio (TETRA); Voice plus Data (V+D); Part 11: Supplementary services stage 2; Sub-part 22: Dynamic Group Number Assignment (DGNA)".
- [15] ETSI ETS 300 392-12-22: "Terrestrial Trunked Radio (TETRA); Voice plus Data (V+D); Part 12: Supplementary services stage 3; Sub-part 22: Dynamic Group Number Assignment (DGNA)".
- [16] ETSI ETS 300 827: "Electromagnetic compatibility and Radio spectrum Matters (ERM); ElectroMagnetic Compatibility (EMC) standard for Terrestrial Trunked Radio (TETRA) and ancillary equipment".
- [17] ETSI ETS 300 395-2: "Terrestrial Trunked Radio (TETRA); Speech codec for full-rate traffic channel; Part 2: TETRA codec".
- [18] 89/336/EEC: "Council Directive 89/336/EEC of 3 May 1989 on the approximation of the laws of the Member States relating to electromagnetic compatibility".
- [19] ETSI ETS 300 607-1: "Digital cellular telecommunications system (Phase 2); Mobile Station (MS) conformance specification; Part 1: Conformance specification (GSM 11.10-1 version 4.26.0)".

3 Definitions, symbols and abbreviations

3.1 Definitions

For the purposes of the present document, the following terms and definitions apply:

Refer to EN 300 392-2 [1], clause 3 for common definitions.

accreditation body: body that conducts and administers a laboratory accreditation system and grants accreditation

receive band of the equipment: maximum frequency range (declared by the manufacturer) over which the receiver can be operated without reprogramming or realignment

accredited laboratory: testing laboratory to which accreditation has been granted

testing laboratory: laboratory that performs tests

transmit band of the equipment: maximum frequency range (declared by the manufacturer) over which the transmitter can be operated without reprogramming or realignment

3.2 Symbols

For the purposes of the present document, the following symbols apply:

f_{lo}	local oscillator frequency applied to first receiver mixer
$if_1 \dots if_n$	receiver intermediate frequencies
P_{MS}	access power
R_{lev}	averaged signal level received by MS

3.3 Abbreviations

For the purposes of the present document, the following abbreviations apply:

Refer to EN 300 392-2 [1], clause 3 for common abbreviations.

B	Measurement bandwidth
BER	Bit Error Ratio
C/I	Carrier to Interference ratio
dBc	Decibels relative to carrier power
dBm	Decibels relative to one mW
MER	Message Erasure Rate
PACQ	Probability of synchronization burst ACQuisition
PRBS	Pseudo Random Bit Sequence
PUEM	Probability of Undetected Erroneous Message
RF	Radio Frequency
RMS	Root Mean Square
Rx	Receiver
SB	Synchronization Burst
Tx	Transmitter

4 General

4.1 Presentation of equipment for testing purposes

Each equipment submitted for type testing shall fulfil the requirements of the present document on all channels over which it is intended to operate. The manufacturer, or other applicant, shall provide one or more production model(s) of the equipment, as appropriate, for type testing. If type approval is given on the basis of tests on pre-production models, those models shall be manufactured in accordance with the same production drawings and manufacturers specifications as the later production models. This fact shall be declared by the manufacturer in the application form. For more details refer to ETS 300 113 [5].

4.1.1 Facilities and information required for testing

The applicant shall, when submitting equipment for type testing, provide the following facilities:

- at least one antenna connector as a test point;
- for equipment supporting diversity, or for any other reason having more than one antenna connector, the applicant shall supply coupling and/or terminating devices so that the tests can be performed via a single antenna connector;
- TETRA equipment, for example PDO radio packet modem modules which may not have an antenna connector, may be submitted for type testing by the manufacturer, or other applicant, if a suitable jig or adapter is supplied which allows the conducted tests to be carried out;
- specific test modes, as defined in subclause 5.2;
- a test connector which provides decoded data output for all uplink logical channels in the case of BS and downlink logical channels in the case of MS to be tested. The test connector shall also provide any test signalling data. The use of the term 'Test Connector' throughout this specification shall mean either a physical connection, as defined in annex C, or a virtual connection by means of an RF Loopback Facility as defined in annex D;
- for BS equipment a trigger signal which can be used by the test equipment for uplink synchronization. The trigger signal shall be sent once within a multiframe structure and it shall have an arbitrary but fixed relationship (frame, timeslot), defined by the base station manufacturer, to the multiframe structure. The trigger signal shall have TTL level, the timing uncertainty shall be less than $\pm 2,5 \mu\text{s}$ and the rise time and fall time shall each be less than 50 ns;
- a means to connect the equipment to the test power source according to clause 6.

Equipment submitted for type testing shall be capable of performing conformance tests using the T1 Test Signal, whether or not the optional requirements of the RF Loopback Facility are implemented. It is at the discretion of the test laboratory whether to implement a test system supporting the optional requirements of the RF Loopback Facility.

The applicant shall provide the following information to the test laboratory:

- power class of equipment;
- receiver class A, B or E (MS only);
- other capabilities and options implemented in equipment, including V+D or PDO, traffic channels supported;
- information related to radio sub-system of equipment, i.e. transmit and receive frequency bands, first local oscillator frequency (f_{lo}) and intermediate frequencies ($if_1 \dots if_n$) of receiver;
- description how to use equipment in specific test modes and test connector interface details;
- information of power source used in equipment.

4.1.2 Choice of radio frequency channels to be tested

The tests described in clauses 8, 9 and 10 shall be performed on one or more frequency channels selected from the lowest 5, the highest 5 and the middle 5 radio frequency channels of either the transmit or receive band of the equipment, whichever is appropriate. The channels required to be tested are defined in clauses 8, 9 and 10 for each individual test.

The use of the terms 'lowest radio frequency channel', 'highest radio frequency channel' and 'middle radio frequency channel' throughout this specification shall mean one of the lowest 5, one of the highest 5 and one of the middle 5 radio frequency channels respectively.

4.1.3 Interpretation of the measurement results

The interpretation of the results recorded in the test report for the measurements described in the present document shall be as follows:

- a) the measured value related to the corresponding limit will be used to decide whether an equipment meets the minimum requirements of the specification in accordance with the shared risk method;
- b) the actual measurement uncertainty of the test laboratory carrying out the measurement, for each particular measurement, shall be included in the test report;
- c) the values of the actual measurement uncertainty shall be, for each measurement, equal to or lower than the figures given in clause 11. The measurement uncertainty requirements given in this specification corresponds to a confidence level of 95 %, unless otherwise stated. The confidence level is the probability that the true value of the measured parameter lies within the range of values bounded by the uncertainty as described in ETR 028 [4].

This procedure for using maximum acceptable uncertainty values is valid until superseded by other appropriate ETSI publications covering this subject. The use of the measured value has been chosen because there is no definitive standard allowing for measurement uncertainty at the time of publication of the present document. Therefore, the measurement uncertainty shall be used to assess the quality of the actual measurement. The measurement uncertainty values can also be used by accreditation authorities during their accreditation procedures to ensure compliance of type testing to ETSI standards.

4.2 Mechanical and electrical design

4.2.1 General

The equipment submitted for type testing by the manufacturer or other applicant, shall be designed, constructed and manufactured in accordance with sound engineering practice and with the aim to minimize harmful interference to other equipment and services.

4.2.2 Controls

Those controls which if maladjusted might increase the interfering potentialities of the equipment shall not be accessible to the user.

4.2.3 Marking

The equipment shall be marked in a visible place. This marking shall be legible, tamperproof and durable. The marking shall include:

- the name of the manufacturer or his trade mark;
- type number of designation and serial number;
- type approval number (when allocated by appropriate authorities).

5 Radio test configuration, test signals and test modes

This clause outlines, in terms of functional blocks, the test system required to perform the radio test procedures and test modes used in clauses 8, 9 and 10.

5.1 General functional radio test configuration

The radio test system configuration shown in figure 1 is presented for information only and is not mandatory. The equipment under test shall be connected to the test system via the antenna connector. For the purposes of testing, all TETRA stations shall have at least one antenna connector as specified by the manufacturer.

The base station equipment under test may include, at the discretion of the manufacturer, some optional items if they are necessary to meet the requirements of the present document, such as receiver splitters/low noise amplifiers, transmitter combiners and duplex filtering. In the case of equipment comprising several transmitters, only one transmitter shall be transmitting during all measurements, except for measuring intermodulation attenuation. Depending on the configuration of an equipment the antenna connection may be common for both the transmitter and receiver (at the input to a duplex filter for example) or separate. The equipment must comply to the present document at the antenna connector specified.

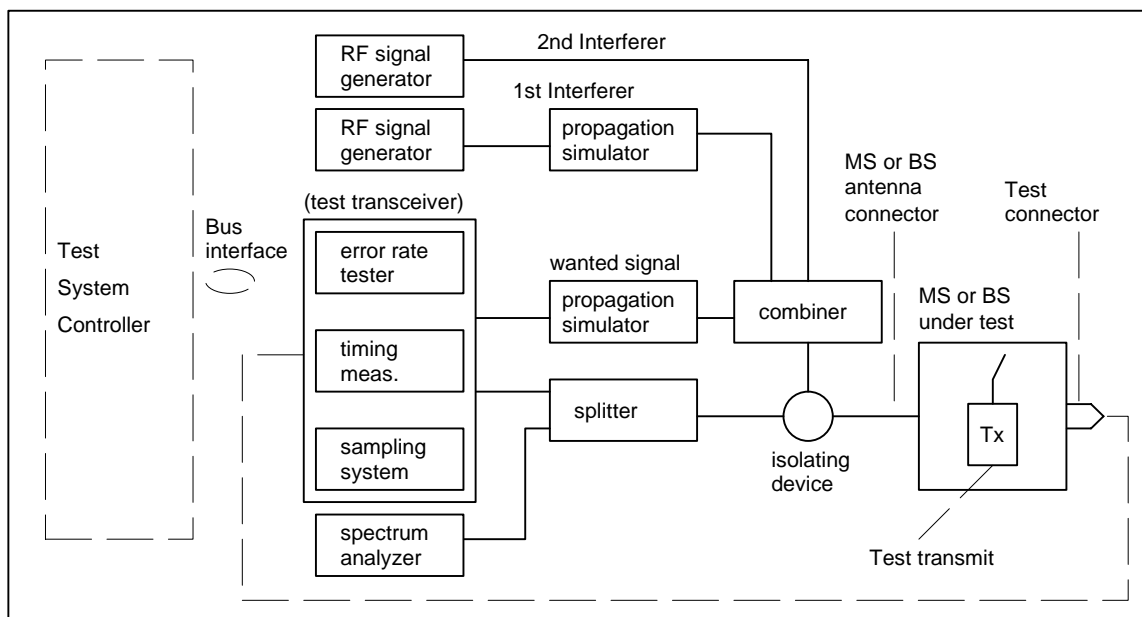

Figure 1: Radio test configuration

5.2 Radio test modes

The manufacturer shall provide the means to operate the equipment under test in either test transmit or test receive modes. The MS under test shall be instructed which test mode to operate in using the Tx_on parameter contained in the BNCH/T(V+D) or MBCH/T(PDO) channels of test signal T1 transmitted by the test system. Further details of test signal T1 and the contents of BNCH/T and MBCH/T are found in subclause 5.3.2 and clause A.3. For a BS under test the manufacturer shall provide the means to configure the BS operation for all type tests to be conducted.

5.2.1 Test receive mode

5.2.1.1 MS test receive mode

The manufacturer shall provide the means to operate the MS under test in MS test receive mode over the frequency range which includes at least the declared V+D downlink RF carrier frequency range and, in the case of an MS with DMO capability, the declared DMO RF carrier frequency range. The receiver of the MS under test shall be set to the same frequency as test signal T1 using the method provided by the manufacturer.

In test receive mode the MS under test shall provide at the test connector a decoded data output for each downlink logical channel (control, traffic) to be tested. The logical channel type to be decoded is indicated using the T1_burst_type parameter in the BNCH/T(V+D) or MBCH/T(PDO).

In all cases whenever the MS decodes a timeslot containing BSCH and BNCH/T(V+D) or MBCH/T(PDO) the MS shall provide the data decoded from these channels at the test connector. In the case where the MS detects an erroneous message on the BSCH, BNCH/T(V+D) or MBCH(TPDO) transmitted by the test equipment during frame 18, the MS shall remain in the same state as it was on frames 1 to 17.

5.2.1.2 BS test receive mode

Using the method provided by the manufacturer, the BS in test receive mode shall be configured to receive the desired logical channel type from the test system. The BS shall operate in its normal mode and provide at the test connector the decoded data output of each uplink logical channel tested.

A V+D BS shall be configured to receive the desired logical channel on timeslot 1 of each uplink frame. During testing the test system shall use the down link BS transmissions to synchronize its uplink burst frequency and timing. The BS shall transmit in timeslot 1 of frame 18 a downlink synchronization burst according to table 1.

Table 1: Base Station down link synchronization burst

Burst type	Block 1	Block 2	Broadcast Block
synchronization	BSCH	BNCH/T	AACH

The downlink synchronization burst contains both BSCH and BNCH/T channels, which includes the T1_burst_type parameter indicating the logical channel the BS is expecting to receive. The BNCH/T is a logical channel specific to the test mode. The contents of the BSCH and BNCH/T channels used during testing are defined in clause A.3. For a V+D BS in continuous mode time slots 1 to 4 of downlink frames 1 to 17 and time slots 2 to 4 of downlink frame 18 are filled with a channel type 1 signal, see subclause 5.3.2 for details of channel types. For a V+D BS in discontinuous mode time slot 1 of downlink frames 1 to 17 are filled with a channel type 1 signal.

The values of MCC + MNC + BCC in the BSCH shall form the 30 bits of the extended colour code which is used to generate the scrambling sequence for all downlink and uplink logical channels, except for the BSCH itself where the 30 bits shall be set equal to zero. The test equipment shall use the scrambling sequence indicated by the BS under test.

Unless otherwise specified the following configuration shall be used:

- channel type 1 (see subclause 5.3.2 for details);
- the parameters MS_TXPWR_MAX_CELL shall be set to 15 dBm;
- the parameter ACCESS_PARAMETER shall be set to -53 dBm.

A PDO BS shall transmit in sub burst 1 a down link synchronization burst according to table 2.

Table 2: Sub burst type

Sub burst type	
synchronization	MBCH/T

The downlink synchronization burst shall be used by the test system to synchronize its uplink sub burst frequency and timing.

The MBCH/T is a logical channel specific to the test mode. The contents of the MBCH/T used during testing are defined in clause A.3. On down link sub bursts 2 to 150 a channel type 6 signal shall be sent by the BS under test.

Unless otherwise specified the following configuration shall be used:

- channel type 6;
- start of reservation value 30 (equivalent to 240 symbol durations);
- the parameters MS_TXPWR_MAX_CELL shall be set to 15 dBm;
- the parameter ACCESS_PARAMETER shall be set to -53 dBm.

In the case of testing a receive-only BS, the manufacturer shall also provide a BS transmitter and the required interconnections with the receive-only BS for synchronization purposes.

5.2.2 Test transmit mode

5.2.2.1 MS V+D testing

The manufacturer shall provide the means to operate the MS under test in MS test transmit mode over the frequency range which includes at least the declared V+D uplink RF carrier frequency range and, in the case of an MS with DMO capability, the declared DMO RF carrier frequency range. In test transmit mode, the MS under test may use the Main Carrier, Frequency Band, Offset, Duplex Spacing and Reverse Operation parameters contained in the BNCH/T channel of test signal T1 to set its transmit frequency. If the MS duplex spacing or reverse operation capabilities are fixed, the MS shall ignore these parameters.

In test transmit mode the MS under test shall transmit either a normal uplink burst or control uplink burst, as indicated by the Tx_Burst_type parameter of the BNCH/T. The MS shall be synchronized in time and frequency to the test signal T1 and shall transmit only on timeslot 1.

In test transmit mode the MS shall begin by transmitting a typical CLCH burst on subslot 1 of frame 18 followed by transmission of TCH/7,2 normal uplink bursts on frames 1 to 17 or SCH/HU control uplink burst on subslot 1 of frames 1 to 17, the sequence then repeating. Further CLCH opportunities are therefore available every multiframe. A bit stream, produced by repeating a pseudo random sequence with a length of 511 bits according to ITU-T Recommendation O.153 [3], shall be used as the information to be transmitted over the logical channel, the sequence then continues across multiframe without breaks after the CLCH slots. The MS shall set its transmit power according to the measured signal strength of signal T1 and the decoded power control parameters in the BNCH/T channel.

In all MS transmitter testing the test system shall continuously transmit test signal T1 with channel type 1 in timeslot 1 of frames 1 to 17 and synchronization burst containing a BSCH and BNCH/T in timeslot 1 of frame 18. In timeslots 2 to 4 of frames 1 to 18 channel type 0 shall be transmitted.

In test transmission mode the MS shall continue to monitor the BSCH and BNCH/T transmitted by the test equipment on frame 18.

5.2.2.2 MS PDO testing

In test transmit mode the MS under test shall transmit a sequence of NBCH normal uplink sub bursts. The MS transmissions shall begin with an uplink start sub burst with normal linearization followed by an alternating sequence of uplink even and uplink odd sub bursts. The MS transmission shall be terminated using an uplink end sub burst. In test transmit mode the MS transmissions are started and stopped using the down link busy flag generated by the test system. A bit stream, produced by repeating a pseudo random sequence with a length of 511 bits according to ITU-T Recommendation O.153 [3], shall be used as the information to be transmitted over the logical channel.

The MS shall set its transmit power according to the measured signal strength of signal T1 and the decoded power control parameters in the MBCH/T channel.

5.2.2.3 BS V+D & PDO testing

Using the method provided by the manufacturer, the BS in test transmit mode shall be configured to transmit the desired down link logical channel and burst/sub burst type. The BS shall operate in its normal mode e.g. continuous or discontinuous mode. For a V+D BS in discontinuous mode the BS shall transmit only in time slot 1 of each frame. A bit stream, produced by repeating a pseudo random sequence with a length of 511 bits according to ITU-T Recommendation O.153 [3], shall be used as the information to be transmitted over the logical channel. The BS transmission may begin with a BLCH burst and, if required, shall include further BLCH bursts not exceeding one occurrence per four multiframe periods, which shall only occur in block 2 of a Normal Downlink Burst with SCH/HD in block 1 (using Normal Training sequence 2) defined in EN 300 392-2 [1] clause 9.

A V+D BS shall transmit in timeslot 1 of frame 18, a synchronization burst containing BSCH and BNCH/T information. A V+D BS operating in continuous mode shall transmit a channel type 1 signal in time slots 1 to 4 of frames 1 to 17 and time slots 2 to 4 in frame 18. A V+D BS operating in discontinuous mode shall transmit a channel type 1 signal in timeslot 1 of frames 1 to 17 only.

In the case of PDO BS a synchronization sub burst containing MBCH/T information shall be sent on sub burst 1 and a channel type 6 signal shall be sent on sub bursts 2 to 150.

5.3 Radio test signals

5.3.1 General

In principle the modulation of the test signals T1 and T2, to be described below, shall comply with EN 300 392-2 [1], clause 5. The modulation filter is specified by a set of windowed discrete impulse response samples, $\{g'_j\}$, where $j=0\dots N-1$ and,

$$g'_j = w_j g\left(TN_s\left(\frac{j}{N-1} - \frac{1}{2}\right)\right)$$

where $g(t)$ is the symbol waveform defined in EN 300 392-2 [1], clause 5, N_s is the number of symbols spanned by the filter and T is the symbol duration as defined in EN 300 392-2 [1], clause 5. N_s shall be at least 15. The window coefficients, w_j , are defined by:

$$w_j = 1 - \left(\frac{j - \frac{1}{2}(N-1)}{\frac{1}{2}(N+1)} \right)^2$$

The test transmitter shall be sufficiently linear with respect to amplitude and phase (active linearization should be avoided whenever possible) to meet the requirements in annex B, clause B.1.

5.3.2 Test signal T1 (TETRA wanted signal)

The T1 signal sequence shall comply with the TETRA (V+D or PDO) air interface multiframe, frame and slot/burst/sub burst structure and is the wanted signal transmitted by the test system during frames 1 to 17 in all receiver tests. The information transmitted by the test system in frame 18 of T1 is used for test control purposes. The slot structure of T1 in frames 1 to 17 is dependant upon the type of receiver test being conducted, defined by the channel type number.

5.3.2.1 MS V+D testing

During MS V+D receiver testing, the test system shall transmit in timeslot 1 of T1 continuous down link burst and channel types according to the tables 3 and 4.

On frame 18 according to table 3.

Table 3: Test system transmission

Burst type	Block 1	Block 2	Broadcast Block
synchronization	BSCH	BNCH/T	AACH

The BNCH/T is a logical channel specific to the test mode. The contents of the BSCH and BNCH/T to be used during the test are given in clause A.3. The Main Carrier, Frequency Band and Offset parameters contained in the BNCH/T shall indicate the downlink frequency of the T1 test signal being generated. The Duplex Spacing and Reverse Operation parameters contained in the BNCH/T shall indicate the required uplink frequency with respect to the indicated downlink frequency. These parameters are defined in EN 300 392-2 [1], clause 21.

On frame 1 to 17 one of the following channel types according to table 4.

Table 4: Channel types

Channel type	Burst type	Block 1	Block 2	Broadcast Block
0	normal	TCH/7,2		AACH
1	normal	TCH/7,2		AACH
2	normal	SCH/F		AACH
3	synchronization	BSCH	SCH/HD	AACH
4	normal	TCH/2,4, N = 1		AACH

The T1 signal shall be scrambled according to EN 300 392-2 [1] clause 8, using the scrambling sequence generated from the 30 bits of the extended colour code, except for the BSCH where the 30 bits shall be set equal to zero. The extended colour code shall be formed from the values of MCC + MNC + BCC which are transmitted in the T1 signal BSCH information defined in table A.12. The MS under test shall use the scrambling sequence indicated by the T1 signal.

A bit stream, produced by repeating a pseudo random sequence with a length of 511 bits according to ITU-T Recommendation O.153 [3], shall be used as the information to be transmitted over the logical channel to be tested. Unless otherwise specified the contents of any logical channels not currently being tested is undefined.

NOTE: For channel type 3, the logical channels BNCH and STCH have the same coding, interleaving format and performance specification as SCH/HD and are not, therefore, specifically tested.

Channel types 1, 2, 3 and 4 shall be tested in continuous transmission mode where channel type 0 is inserted in time slots 2 to 4 of frames 1 to 18.

For MS synchronization burst acquisition performance testing, the normal multiframe structure shall not be respected and the synchronization continuous downlink bursts (including start and stop bursts) carrying BSCH/T shall be transmitted randomly. The period between the start of two synchronization bursts shall be randomly selected in the range between 800 and 25 000 symbol durations, with a step less than or equal to $\frac{1}{4}$ symbol duration. Nothing shall be transmitted in the time interval between synchronization bursts. This special transmission mode is defined as channel type 13.

5.3.2.2 BS V+D testing

During BS V+D receiver testing the test system shall transmit in timeslot 1 of T1 up link burst and channel types according to the tables 5 and 6.

On frame 18 according to table 5.

Table 5: Test system transmission

Channel type	Burst type	Sub slot 1	Sub slot 2
8	normal	SCH/F	

On frame 1 to 17 one of the following channel types according to table 6.

Table 6: Channel types

Channel type	Burst type	Sub slot 1	Sub slot 2
7	normal	TCH/7,2	
8	normal	SCH/F	
9	normal	STCH	STCH
10	normal	TCH/2,4, N = 1	
11	control	SCH/HU	SCH/HU

For BS receiver testing, channel type 7 shall be inserted in time slots 2 to 4 of all uplink frames 1 to 18. A bit stream, produced by repeating a pseudo random sequence with a length of 511 bits according to ITU-T Recommendation O.153 [3], shall be used as the information to be transmitted over the logical channel.

5.3.2.3 MS PDO testing

During MS PDO receiver testing the test system shall transmit T1 down link sub burst and channel types according to the tables 7 and 8.

On sub burst 1 according to table 7.

Table 7: Sub bursts

Channel type	Sub burst type	
5	synchronization	MBCH/T

On sub bursts 2 to 150 according to table 8.

Table 8: Sub bursts

Channel type	Sub burst type	
6	normal	NBCH

A bit stream, produced by repeating a pseudo random sequence with a length of 511 bits according to ITU-T Recommendation O.153 [3], shall be used as the information to be transmitted over the logical channel.

For MS synchronization burst acquisition performance testing, the normal sub-burst structure shall not be respected and the synchronization sub-bursts carrying the MBCH/T shall be transmitted randomly as described in subclause 5.3.2.1. This special transmission mode is defined as channel type 14.

5.3.2.4 BS PDO testing

During BS PDO receiver testing the test system shall transmit T1 up link sub burst and channel types according to table 9.

On uplink sub bursts 1 to 150 according to table 9.

Table 9: Sub bursts

Channel type	Sub burst type	
12	normal	NBCH

A bit stream, produced by repeating a pseudo random sequence with a length of 511 bits according to ITU-T Recommendation O.153 [3], shall be used as the information to be transmitted over the logical channel.

5.3.3 Test signal T2 (TETRA interferer)

Test signal T2 is a pi/4 DQPSK modulated continuous radio signal following the structure of TETRA signals, but with all modulating bits (including training sequences) derived directly from pseudo random bit sequence (with a length of 511 bits according to ITU-T Recommendation O.153 [3]).

T2 is used as an unwanted (modulated) signal.

5.3.4 Test signal T3 (unmodulated interferer)

Test signal T3 is an unmodulated continuous sinusoidal radio signal. T3 is used as an unwanted (unmodulated) signal.

6 Test conditions

6.1 General

Type tests shall be made under normal test conditions and where stated also under extreme test conditions. The test conditions and procedures shall be as specified in subclauses 6.2.1 and 6.2.2.

6.2 Power sources and ambient conditions

During type tests the power source of the equipment shall be replaced by a test power source, capable of producing normal and extreme test voltages as specified in subclauses 6.2.1 and 6.2.2. The internal impedance of the test power source shall be low enough for its effect on the test results to be negligible. For the purpose of tests, the voltage of the power source shall be measured at the input terminals of the equipment. If the equipment is provided with a permanently connected power cable, the test voltage shall be that measured at the point of connection of the power cable to the equipment. In equipment with incorporated batteries the test power source shall be applied as close to the battery terminals as practicable. During tests the power source voltages shall be maintained within a tolerance of ± 1 % relative to the voltage at the beginning of each test.

6.2.1 Normal test conditions

The normal temperature and humidity conditions for tests shall be any convenient combination of temperature and humidity within the common range fulfilling all of the following requirements:

- temperature +15 °C to +35 °C (degrees Celsius);
- relative humidity 5 % to 75 %;
- intended operational humidity range of the IUT.

When it is impracticable to carry out the tests under the conditions stated above, the actual temperature and relative humidity during the tests shall be recorded in the test report.

The normal test voltage for equipment to be connected to the mains shall be the nominal mains voltage. For the purpose of these specifications, the nominal voltage shall be the declared voltage or any of the declared voltages for which the equipment was designed. The frequency of the test power source corresponding to the mains shall be between 49 Hz and 51 Hz.

When the radio equipment is intended for operation from the usual types of regulated lead-acid battery power source of vehicles, the normal test voltage shall be 1,1 times the nominal voltage of the battery (6 V, 12 V, etc.).

For operation from other power sources or types of battery (primary or secondary) the normal test voltage shall be that declared by the equipment manufacturer.

6.2.2 Extreme test conditions

For tests on equipment at extreme ambient temperatures measurements shall be made at an upper temperature and a lower temperature defined as follows:

- the lower temperature shall be -20 °C except for BS equipment where the lowest intended operational temperature of the BS shall apply if this is higher than -20 °C;

- the upper temperature shall be +55 °C except for BS equipment where the highest intended operational temperature of the BS shall apply if this is lower than +55 °C.

NOTE: The following equipment types are classified as MS equipment for the purpose of environmental testing: TMO repeater, DM-MS, DW-MS, DM-REP, DM-GATE, DM-REP/GATE.

The extreme humidity conditions shall be the same as the normal humidity conditions specified in subclause 6.2.1.

The extreme test voltages for equipment to be connected to an ac mains source shall be the nominal mains voltage $\pm 10\%$.

When the equipment is intended for operation from the usual types of regulated lead-acid battery power sources of vehicles the extreme test voltages shall be 1,3 and 0,9 times the nominal voltage of the battery (6 V, 12 V, etc.).

The extreme test voltages for equipment with power sources using non regulated batteries shall be as follows. The upper extreme test voltage shall be the normal test voltage. The lower extreme test voltage shall be:

- for the Leclanche or the lithium-type of battery, 0,85 times the nominal voltage of the battery;
- for the mercury-type or nickel cadmium type of battery, 0,9 times the nominal voltage of the battery;
- for other types of batteries, end point voltage declared by the equipment manufacturer.

However, the lower extreme test source voltages shall be those agreed between the equipment manufacturer and the testing laboratory for the following equipment:

- designed to use other power sources;
- capable of being operated from a variety of power sources;
- designed to include a shut-down facility to ease operation of the equipment at source voltages other than those referred to above.

The conditions shall be recorded in the test report and in the latter case the purpose of including this facility.

The following four extreme test condition combinations are applied while testing TETRA equipment under extreme test conditions:

- LTLV: lower temperature and lower voltage;
- LTHV: lower temperature and higher voltage;
- HTLV: upper temperature and lower voltage;
- HTHV: upper temperature and higher voltage.

Unless otherwise stated tests to be conducted under extreme test conditions shall include all the above temperature and voltage combinations.

6.3 Procedure for tests at extreme temperatures

Before measurements are made, the equipment shall have reached thermal balance in the test chamber. The equipment shall be switched off during the temperature stabilizing period. In the case of equipment containing temperature stabilization circuits designed to operate continuously, the temperature stabilization circuits may be switched on for 15 minutes after thermal balance has been obtained, the equipment shall then meet the specified requirements. If the thermal balance is not checked by measurements, a temperature stabilizing period of at least one hour, or such period as may be decided by the testing laboratory shall be allowed. The sequence of measurements shall be chosen, and the humidity content in the test chamber shall be controlled so that excessive condensation does not occur.

6.3.1 Equipment designed for continuous operation

Before tests at the upper temperature, the equipment shall be placed in the test chamber and left until thermal balance is attained. The equipment shall then be switched on in the transmit state for a period of 30 minutes after which the equipment shall meet the specified requirements.

Before tests at the lower temperature, the equipment shall be left in the test chamber until thermal balance is attained, then switched to the idle (non-transmit) state for a period of 4 minutes, after which the equipment shall meet the specified requirements.

6.3.2 Equipment designed for intermittent operation

Before tests at the upper temperature, the equipment shall be placed in the test chamber and left until thermal balance is attained. The equipment shall then be switched on in the idle (non-transmit) state for a period of four minutes prior to testing. In the case of transmitter CLCH testing, measurement of unwanted emissions shall take place immediately following this period. Prior to further transmitter testing the equipment shall be operated in the transmit state for a period of one minute followed by four minutes in the idle (non-transmit) state before measurements are made.

Before tests at the lower temperature, the equipment shall be left in the test chamber until thermal balance is attained, then switched to the idle (non-transmit) state for a period of one minute after which the equipment shall meet the specified requirements.

7 Technical characteristics

7.1 Transmitter parameter definitions & limits

7.1.1 Transmitter output power

7.1.1.1 Definition

Two parameters are considered here:

- a) average transmitter output power measured over the useful part of a burst;
- b) transmitter output power versus time.

7.1.1.2 Limit values

The following requirements shall be met:

- a) the average transmitter output power measured through the TETRA filter (defined in annex B) under the normal test conditions shall be within $\pm 2,0$ dB of the nominal value specified for the BS or MS power class in EN 300 392-2 [1], clause 6. Under extreme test conditions the average transmitter output power shall be within $+3,0$ dB and $-4,0$ dB of nominal. The average transmitter output power under normal test conditions of the MS at all power control levels below its nominal power class shall be within $\pm 2,5$ dB of the MS power control levels in EN 300 392-2 [1], clause 6. The difference in level between adjacent power control levels shall be $5,0$ dB $\pm 2,5$ dB ($2,5$ dB $\pm 2,5$ dB for the first step for mobiles with power class modifier L). The average transmitter output power at the minimum power level under extreme test conditions shall be within $\pm 4,0$ dB of the minimum MS power control level in EN 300 392-2 [1], clause 6;
- b) for an MS or discontinuous BS, the transmitter output power versus time shall be within the power time mask specified in EN 300 392-2 [1], clause 6, figure 7, measured through the TETRA filter under normal and extreme test conditions. The time periods t_1 , t_2 and t_3 in EN 300 392-2 [1], clause 6, figure 7 are defined in EN 300 392-2 [1], clause 6, table 7.

For BS in discontinuous mode $L_{min} = -40$ dBc and for MS $L_{min} = -70$ dBc.

In any case, no requirement more stringent than -36 dBm applies.

7.1.2 Unwanted output power in non-active transmit state

7.1.2.1 Definition

The unwanted output power in non-active transmit state is the average power emitted by a BS operating in discontinuous mode or MS transmitter, as measured through the TETRA filter (defined in subclause B.1.2.2), over the non active period of non active timeslots occurring between successive burst transmissions. The non-active period excludes the time periods t_1 and t_3 of active timeslots, defined in EN 300 392-2 [1] clause 6 table 7.

7.1.2.2 Limit values

The unwanted output power in non active transmit state shall not exceed for a BS -40 dBc or MS -70 dBc under normal test conditions. In any case, no requirement more stringent than -36 dBm applies.

NOTE: 0 dBc refers to the BS or MS transmit power.

7.1.3 Adjacent channel power due to modulation

7.1.3.1 Definition

The adjacent channel power due to modulation is the average power over the useful part of a burst, as measured through the TETRA filter, emitted by an active BS or MS transmitter at the frequency offsets of ± 25 kHz, ± 50 kHz and ± 75 kHz from the nominal centre frequency of the allocated channel.

7.1.3.2 Limit values

The limit values given in table 10 shall not be exceeded at the listed frequency offsets from the nominal carrier frequency.

Table 10: Maximum adjacent channel power levels

Frequency offset	Maximum level (normal test conditions)	Maximum level (extreme test conditions)
25 kHz	-60 dBc	-50 dBc
50 kHz	-70 dBc	-60 dBc
75 kHz	-70 dBc	-60 dBc

These requirements shall be measured under normal and extreme test conditions. In any case, no requirement more stringent than -36 dBm shall apply.

NOTE: 0 dBc refers to the BS or MS transmit power.

7.1.4 Adjacent channel power due to switching transients

7.1.4.1 Definition

The adjacent channel power due to switching transients is the peak power over the ramp-up and ramp-down periods of a burst, as measured through the TETRA filter, emitted by an active BS transmitter operating in discontinuous mode or an active MS transmitter at frequency offsets of ± 25 kHz from the nominal frequency of the allocated channel.

7.1.4.2 Limit values

The adjacent channel peak power level shall not exceed -50 dBc. In any case, no requirement more stringent than -36 dBm shall apply.

This requirement shall be measured under normal test conditions.

NOTE: 0 dBc refers to the BS or MS transmit power.

7.1.5 Unwanted emissions far from the carrier

7.1.5.1 Definition

These unwanted emissions are emissions (discrete, wide-band noise, modulated or unmodulated) occurring at offsets equal or greater than 100 kHz from the carrier frequency, measured in the frequency range 9 kHz to 4 GHz (9 kHz to 12,75 GHz for equipment capable of operating at frequencies above 470 MHz).

7.1.5.2 Limit values

Discrete Spurious:

The maximum allowed power for each spurious emission shall be less than -36dBm measured in 100 kHz bandwidth in the frequency range 9 kHz to 1 GHz and -30 dBm measured in 1 MHz bandwidth in the frequency range 1 GHz to 4 GHz (1 GHz to 12,75 GHz for equipment capable of operating at frequencies above 470 MHz). Specific measurement methods and lower bandwidths (as defined in table 16) are required both when measuring within $\pm f_{rb}$ of carrier frequency, due to the presence of wideband noise, and in the lower part of the spectrum.

Wideband noise:

The following wideband noise levels measured through the TETRA filter defined in annex B shall not exceed the limits shown in the following table for the power classes as stated and at the listed offsets from the nominal carrier frequency. The requirements apply symmetrically to both sides of the transmitter band.

Table 11: Wideband noise limits

Frequency offset	Maximum wideband noise level		
	MS Nominal power level \leq PL 4 (1 W)	MS Nominal power level = PL 3 (3 W) or PL 3L (1,8 W)	MS Nominal power level \geq PL 2L (5,6 W) BS (all classes)
100kHz - 250kHz	-75 dBc	-78 dBc	-80 dBc
250kHz - 500kHz	-80 dBc	-83 dBc	-85 dBc
500kHz - f_{rb}	-80 dBc	-85 dBc	-90 dBc
$> f_{rb}$	-100 dBc	-100 dBc	-100 dBc

NOTE: f_{rb} denotes the frequency offset corresponding to the near edge of the received band or 5 MHz (10 MHz for frequencies above 520 MHz) whichever is greater. All levels are expressed in dBc relative to the actual transmitted power level, and in any case no limit tighter than -55 dBm for offsets $\leq f_{rb}$ or -70 dBm for offsets $> f_{rb}$ shall apply.

These requirements shall be measured under normal conditions.

7.1.6 Unwanted radiated emissions

7.1.6.1 Definition

Unwanted radiated emissions are emissions (whether modulated or unmodulated) radiated by the cabinet and structure of the equipment (MS or BS). This is also known as cabinet radiation.

7.1.6.2 Limit values

The limits given in subclause 7.1.5.2 shall apply for frequencies between 30 MHz and 4 GHz only.

7.1.7 Unwanted emissions during the BLCH/CLCH (linearization)

7.1.7.1 Definition

These unwanted emissions are emissions produced by a BS or MS, measured in a TETRA filter at a frequency offset of ± 25 kHz from the nominal carrier frequency, while the BS is transmitting a linearization burst on the BS Linearization Channel (BLCH) or a MS transmitting a linearization burst on the Common Linearization Channel (CLCH).

7.1.7.2 Limit values

The sum of the time periods during which the peak power, at a frequency offset of ± 25 kHz during the BLCH/CLCH, is above -45 dBc shall not exceed 1 ms. This peak power shall never exceed -30 dBc.

NOTE: 0 dBc refers to the transmit power during normal operation after the BLCH/CLCH.

These requirements shall be measured under normal and extreme test conditions.

7.1.8 Transmitter intermodulation attenuation

7.1.8.1 Definition

Transmitter intermodulation attenuation is the ratio of the power level of the wanted signal to the power level of an intermodulation component. It is a measure of the capability of the transmitter to inhibit the generation of signals in its non-linear elements caused by the presence of the useful carrier and an interfering signal reaching the transmitter via its antenna.

7.1.8.2 Limit values

7.1.8.2.1 MS Limit values

For a MS transmitter operating at the nominal power defined by its class, the intermodulation attenuation shall be at least 60 dB for any intermodulation component when measured in 30 kHz bandwidth. The interfering signal shall be unmodulated and have a frequency offset of at least 500 kHz from the carrier frequency. The power level of the interfering signal shall be 50 dB below the level of the modulated output signal from the transmitter under test.

This requirement shall be measured under normal test conditions.

7.1.8.2.2 Limit values for single BS transmitter

The intermodulation attenuation of the base station equipment shall be at least 70 dB for any intermodulation component when measured in 30 kHz bandwidth. However, in the case of base station equipment with only one transmitter and which is not intended to be collocated with other radio transmitting equipment, an intermodulation attenuation of at least 40 dB shall be sufficient. The interfering signal shall be unmodulated and have a frequency offset of at least 500 kHz from the carrier frequency. The power level of the interfering signal shall be 30 dB below the power level of the modulated output signal from the transmitter under test.

If the intermodulation attenuation is achieved by additional, internal or external, isolating devices they shall be included in the measurements.

In any case no requirement more stringent than -36 dBm shall apply.

All power levels stated in the cases above are referring to the antenna connector of the base station.

These requirements shall be measured under normal test conditions.

7.1.8.2.3 Limit values for Intra BS intermodulation

In a BS, intermodulation may be caused by combining several transmitters and carriers to feed a single antenna.

For all transmitters of a single TETRA base station, the power of any intermodulation components, when measured in a 30 kHz bandwidth, shall not exceed -60 dBc in the relevant downlink frequency band. In any case no requirement more stringent than -36 dBm shall apply.

NOTE: The value of -60 dBc refers to the carrier power of the transmitter with the highest power output, measured at the antenna connector of the base station.

In the case where the performance is achieved by additional, internal or external isolating devices (such as circulators) they shall be supplied at the time of type testing and shall be used for measurements. The frequencies of the individual transmitters used during testing shall be stated in the test report.

This requirement shall be measured under normal test conditions.

7.2 Receiver parameter definitions and limits

7.2.1 General

The required minimum number of samples (bits in the case of BER measurements and messages in the case of MER and PUEM measurements) and the test limit error rates used in the following receiver tests have been defined such that:

- a) the probability of passing a bad unit is lower than 0,3 %;
- b) the probability of passing a good unit, operating on the limit of performance, is at least 99,5 %.

A unit shall be considered bad if its true BER/MER performance is worse than 1,5 times the specified BER/MER in static conditions and worse than 1,26 times the specified BER/MER in dynamic (fading multipath) conditions. These values have been adopted (taking into account the expected shapes of the BER/MER performance) in order to not to pass an unit with a sensitivity or interference rejection performance, 1 dB worse than that of an unit which just meets the specification.

NOTE: The above definition of a bad unit does not apply to PUEM measurements.

Using at least the minimum number of samples shown in the tables of annex A, clause A.2, the MS or BS shall not exceed the test limits shown in the tables of annex A, clause A.2. These test limits (with the exception of PUEM measurements) are 1,22 times worse than the specified performance in static conditions, and 1,12 times worse than the specified performance in dynamic conditions, corresponding to a performance 0,5 dB worse than that specified. These values satisfy the requirements of a) and b) above. It is permitted to run the test over more samples than the value stated for minimum number of samples. The effect of increasing the number of samples is always to give a higher probability that a good unit will pass and a lower risk that a bad unit will pass, according to the definitions of good and bad unit in this clause.

All signal levels are referenced to the antenna connector of the equipment under test. The signal level is the available average power into 50 Ω measured over the useful part of a burst through the TETRA filter (defined in annex B).

7.2.2 Nominal error rates

7.2.2.1 Definition

The nominal error rate is a measure of the receiver performance under nominal channel conditions. Nominal channel conditions are defined as a received signal level \geq -85 dBm with no interference under both static and fading conditions.

7.2.2.2 Limit values

The nominal bit error rate shall be measured. The cases to be tested and the corresponding limit values are given in the tables of clause A.2.

These requirements shall be measured under normal test conditions.

7.2.3 Reference sensitivity performance

7.2.3.1 Definition

The minimum required reference sensitivity performance is specified for V+D and PDO equipment according to test condition, logical channel, propagation condition, BS transmission mode and the receiver class.

7.2.3.2 Limit values

The maximum dynamic and static reference sensitivity levels for a BS receiver under normal and extreme test conditions shall not exceed the signal levels shown in table 12.

Table 12: BS receiver minimum reference sensitivity

Test condition	Dynamic ref. sensitivity	Static ref. sensitivity
normal	-106 dBm	-115 dBm
extreme	-100 dBm	-109 dBm

The maximum dynamic and static reference sensitivity levels for a MS receiver under normal and extreme test conditions shall not exceed the signal levels shown in table 13.

Table 13: MS receiver minimum reference sensitivity

Test condition	Dynamic ref. sensitivity	Static ref. sensitivity
normal	-103 dBm	-112 dBm
extreme	-97 dBm	-106 dBm

The cases to be tested and the corresponding limit values for BER or MER are given in the tables of clause A.2. Reference sensitivity requirements shall be tested under both normal and in certain cases extreme test conditions

Only in the case where a MS or BS supports protected circuit mode data, shall the TCH/2,4 receiver sensitivity measurement be conducted.

All MS V+D equipment shall achieve a PUEM $< 10^{-4}$ on the AACH and a PUEM $< 10^{-5}$ on the BSCH, SCH/HD, SCH/F and BNCH, measured in dynamic conditions. All MS PDO equipment shall achieve a PUEM $< 10^{-5}$ on the MBCH and NBCH, measured in dynamic conditions. All BS equipment shall achieve a PUEM $< 10^{-5}$ on the SCH/HU and SCH/F (V+D) or NBCH (PDO), measured in dynamic conditions.

The cases to be tested, the number of required samples and the test limit values for PUEM are given in clause A.2. The PUEM tests shall be conducted under normal test conditions only.

7.2.4 Reference interference performance

7.2.4.1 Definition

The minimum required reference interference performance (for co-channel C/Ic or adjacent channel C/Ia) is specified for V+D and PDO equipment according to test condition, channel type, propagation condition and the receiver class of the equipment.

7.2.4.2 Limit values

The reference interference ratio shall be as follows:

- for co-channel interference: C/Ic = 19 dB;
- for adjacent channel interference: C/Ia = -45 dB (under normal test conditions);
C/Ia = -35 dB (under extreme test conditions).

In the case of co-channel interference these specifications apply for a wanted input signal level of -85 dBm, and in the case of adjacent channel interference, for a wanted input signal 3 dB above the dynamic reference sensitivity level under appropriate test conditions. In the case of co-channel interference the interference is a continuous TETRA random modulated signal (test signal T2) subjected to an independent realization of the same propagation condition as the wanted signal. In the case of adjacent channel interference the interference is a continuous TETRA random modulated signal (test signal T2) subjected to static propagation conditions.

The cases to be tested and the corresponding limit values for BER or MER are given in the tables of clause A.2.

These requirements shall be measured under normal and in the case of adjacent channel interference, extreme test conditions.

7.2.5 Blocking characteristics

7.2.5.1 Definition

Blocking is a measure of the capability of the receiver to receive a modulated wanted input signal in the presence of an unwanted unmodulated input signal on frequencies other than those of the spurious responses or the adjacent channels, without this unwanted input signal causing a degradation of the performance of the receiver beyond a specified limit. The blocking performance specification shall apply at all frequencies within the relevant receive band of the equipment, except those at which spurious responses occur (see subclause 7.2.6).

7.2.5.2 Limit values

The reference sensitivity performance for the TCH/7,2 for V+D equipment or NBCH for PDO equipment, as specified in clause A.2 under static conditions, shall be met when the following signals are simultaneously input to the receiver:

- a wanted signal at nominal receive frequency f_0 , 3 dB above the static reference sensitivity level as specified in subclause 7.2.3.2;
- a continuous sine wave signal (test signal T3) at frequency offsets of ± 1 MHz, ± 2 MHz, ± 5 MHz and ± 10 MHz from the nominal receive frequency (f_0) and at a minimum level of -25 dBm.

This requirement shall be measured under normal test conditions.

7.2.6 Spurious response rejection

7.2.6.1 Definition

Spurious response rejection is a measure of the capability of a receiver to receive a wanted modulated signal without exceeding a given degradation due to the presence of an unwanted unmodulated signal at any other frequency at which a response is obtained, i.e. for which the blocking limit is not met.

7.2.6.2 Limit values

- a) The reference sensitivity performance for the TCH/7,2 for V+D equipment or NBCH for PDO equipment, as specified in annex A, clause A.2 under static conditions, shall be met when the following signals are simultaneously applied to the receiver:
 - a wanted signal at nominal receive frequency f_0 , 3 dB above the static reference sensitivity level as specified in subclause 7.2.3.2;
 - a continuous sine wave signal (test signal T3) at frequency f as defined in annex A, clause A1 at a level of -45 dBm.
- b) The number of spurious responses where the blocking requirements as defined in subclause 9.6 a) are not met shall not exceed $0,05 \times$ (number of frequency channels in the limited frequency range, as defined in clause A.1).

This requirement shall be measured under normal test conditions.

7.2.7 Intermodulation response rejection

7.2.7.1 Definition

Intermodulation response rejection is a measure of the capability of the receiver to receive a wanted modulated signal without exceeding a given degradation due to the presence of two or more unwanted signals with a specific frequency relationship to the wanted signal frequency.

7.2.7.2 Limit values

The reference sensitivity performance for the TCH/7,2 for V+D equipment or NBCH for PDO equipment, as specified in annex A, clause A.2 under static conditions, shall be met when the following signals are simultaneously input to the receiver:

- a wanted signal at nominal receive frequency f_0 , 3 dB above the static reference sensitivity level as specified in subclause 7.2.3.2;
- a continuous sine wave signal (test signal T3) at frequency f_1 with level -47 dBm;
- a pi/4 DQPSK modulated continuous radio signal (test signal T2) at frequency f_2 , with level -47 dBm, such that $f_0 = 2f_1 - f_2$ and $|f_2 - f_1| = 200$ kHz.

This requirement shall be measured under normal test conditions.

7.2.8 Unwanted conducted emissions

7.2.8.1 Definition

Unwanted emissions from a MS or BS when in reception (non-transmit state) are signals at any frequency emitted by the MS or BS.

7.2.8.2 Limit values

The unwanted conducted emissions shall be less than -57 dBm measured in the frequency range from 9 kHz to 1 GHz as measured in a 100 kHz bandwidth. For equipment only capable of operating at frequencies below 470 MHz, the unwanted conducted emissions shall be less than -47 dBm measured in the frequency range from 1 GHz to 4 GHz, as measured in a bandwidth of 1 MHz. For equipment capable of operating at frequencies above 470 MHz, the unwanted conducted emissions shall be less than -47 dBm from 1 GHz to 12,75 GHz, as measured in a bandwidth of 1 MHz.

These requirements shall be measured under normal test conditions.

7.2.9 Unwanted radiated emissions

7.2.9.1 Definition

Unwanted radiated emissions are emissions (whether modulated or unmodulated) radiated by the cabinet and structure of the equipment (MS or BS), when the equipment is in the non-transmit state.

7.2.9.2 Limit values

The limits given in subclause 7.2.8.2 shall apply for frequencies between 30 MHz and 4 GHz only.

7.3 Transmitter/receiver parameter definitions & limits

7.3.1 Modulation accuracy

7.3.1.1 Definition

Modulation accuracy is defined according to EN 300 392-2 [1], clause 6 as a difference between the actual transmitted signal waveform and the ideal signal waveform. The difference is specified in terms of vector error magnitudes at a symbol time. The parameters to be measured are RMS vector error and peak vector error, as defined in EN 300 392-2 [1], clause 6. In addition the residual carrier magnitude of the transmitter shall be measured.

7.3.1.2 Limit values

RMS vector error: less than 0,1 in any burst.

Peak vector error: less than 0,3 for any symbol.

Residual carrier magnitude shall be less than 5 % in any burst.

These requirements shall be measured under normal test conditions.

7.3.2 Carrier frequency accuracy

7.3.2.1 Definition

Carrier frequency accuracy (error) is defined as a difference between the actual transmitted carrier frequency and its nominal value.

7.3.2.2 Limit values

The BS carrier frequency error in any burst shall be within $\pm 0,2$ ppm for frequencies up to 520 MHz. At carrier frequencies above 520 MHz the BS frequency error in any burst shall be within $\pm 0,1$ ppm. This requirement shall be measured under normal test conditions.

NOTE: The BS frequency accuracy is specified in ppm due to the requirement for timebase accuracy defined in EN 300 392-2 [1] subclause 7.5.

The MS carrier frequency error in any burst shall be within ± 100 Hz measured under normal test conditions.

7.3.3 MS receiver performance for synchronization burst acquisition

7.3.3.1 Definition

This subclause specifies reference sensitivity performance of a MS receiver for the acquisition of the synchronization (sub) burst (SB) in V+D and PDO standard. The performance is defined in terms of the probability PACQ of detecting a single transmitted SB and correctly decoding its BSCH (MBCH) information for the condition where the MS is listening on the frequency while the SB is transmitted, and where the MS is already frequency synchronized but not synchronized in terms of time slots.

7.3.3.2 Limit values

The MS receiver PACQ performance specified in table 14 shall be met with a wanted signal level at the dynamic reference sensitivity level.

Table 14: MS receiver PACQ

Receiver Class	Propagation Condition	PACQ
A, E	HT200	0,8
B	TU50	0,8

The propagation models specified (TU50, HT200) are defined in EN 300 392-2 [1] subclause 6.6.3.3.

For test purposes, with a limited number of samples (20 synchronization bursts) a test limit of 0,55 instead of 0,8 shall apply for both classes. This corresponds to 11 successful acquisitions. This specification applies to continuous or discontinuous downlink mode.

This requirement shall be measured under normal test conditions.

7.3.4 MS Frame alignment performance

7.3.4.1 Definition

Frame alignment performance is defined as the capability of the MS to adjust its burst transmission time with reference to the signals received from the serving BS, when the MS-BS distance is varying with time.

7.3.4.2 Limit values

The timing of each burst sent by the MS shall not differ by more than $\pm 1/4$ symbol duration (EN 300 392-2 [1], clause 7) from the timing reference received from the BS.

This requirement shall be measured under normal test conditions.

7.3.5 MS link control

7.3.5.1 Definition

The MS shall be capable of setting its initial transmit output power based upon the received signal strength measured and the power control parameters broadcast by the serving BS on the BNCH (V+D) or MBCH (PDO).

7.3.5.2 Limit values

The MS shall use its nominal power control level that is closest to P_{MS} , where P_{MS} is defined by EN 300 392-2 [1], clause 23:

$$- P_{MS} = \text{MIN} (\text{MS_TXPWR_MAX_CELL}, \text{ACCESS_PARAMETER} - R_{lev});$$

where:

- MS_TXPWR_MAX_CELL = maximum MS transmit power allowed in the cell;
- ACCESS_PARAMETER = parameter for access power calculation;
- R_{lev} = averaged signal level received by the MS.

All values are expressed in dBm.

NOTE: ACCESS_PARAMETER is based on the BS power and configuration and on the required mean receive power level at the BS.

The measured MS transmit power shall be within ± 9 dB of the value P_{MS} defined above, when P_{MS} is within the MS power control range.

The tolerances specified above include the contribution of the following sources of error:

- acceptable signal strength measurement uncertainty in the MS (EN 300 392-2 [1], clause 23): ± 4 dB;
- nominal steps of 5 dB between adjacent MS power control levels: $\pm 2,5$ dB;
- acceptable uncertainty in setting the MS transmit power: $\pm 2,5$ dB.

In any case, when P_{MS} is outside the MS power control range by more than 3,5 dB the highest or lowest power control level supported by the MS shall be used accordingly. In that case the power tolerances specified in subclause 7.1.1 shall apply.

In order to reduce the uncertainties contributing to the tolerance specified above, the link control test shall be performed using the test cases shown in table 17. For each test case, the measured MS transmit power shall not exceed the maximum power shown in table 17.

These requirements shall be measured under normal test conditions.

8 Methods of measurement for transmitter parameters

8.1 Transmitter output power

The test shall be carried out under normal and extreme (LTLV, HTHV) test conditions specified in clause 6. A test configuration as presented in subclause 5.1 should be applied. The sampling system described in subclause B.1.2 shall be employed.

8.1.1 MS transmitter output power

- a) The MS shall be connected to the test system. In the case of V+D MS testing the test system shall transmit test signal T1 continuously with channel type 1 in timeslot 1 of frames 1 to 17 and a synchronization burst containing BSCH and BNCH/T(V+D) parameters in timeslot 1 of frame 18. In frames 1 to 18 channel type 0 shall be inserted into time slots 2 to 4. Test signal T1 level and BNCH/T parameters shall be initially set as detailed in test case 1 below and transmitted on the desired downlink frequency.
 - In the case of PDO MS testing the test system shall transmit test signal T1 continuously with MBCH/T in sub burst 1 followed by a NBCH (channel type 6) in sub bursts 2 to 150. Test signal T1 level and MBCH/T parameters shall be initially set as detailed in test case 1 below and transmitted on the desired downlink frequency.
 - All T1 signal levels are referenced to the antenna connector of the equipment under test. The signal level is the available average power into 50Ω measured over the useful part of a burst through the TETRA filter (defined in annex B). Table 15 refers.

Table 15: Test cases to set nominal MS power control levels

test case	T1 level dBm	Access_parameter dBm	MS_TXPWR_MAX_CELL dBm	Nominal MS power control level (note)
1	-100	-23	45	PL1
2	-100	-23	40	PL2
3	-100	-23	35	PL3
4	-100	-23	30	PL4
5	-100	-23	25	PL5
6	-100	-23	20	PL6
7	-100	-23	15	PL7

NOTE: Or MS Power Class if lower.

- The MS shall be set to test receive mode for a period of at least 5 seconds in which it will decode BSCH and BNCH/T(V+D) or MBCH/T(PDO) information and measure T1 signal strength. The MS shall then be set to test transmit mode. The MS shall use the T1 level, Access_parameter and MS_TXPWR_MAX_CELL parameters to set its transmitter output power to the nominal MS power control levels for the test cases shown in table 15, as required by each transmitter test.

- b) The sampling system shall capture a representation of the MS transmit burst's (excluding any CLCH transmissions) amplitude and timing. The procedure shall be repeated for 200 bursts and the test system shall calculate the following two parameters:
 - b1) the average power versus time profile during time periods t_1 and t_3 (figure 7 in EN 300 392-2 [1]), extended at least 5 symbol periods before the start of t_1 and at least 5 symbol periods after the end of t_3 , sampled at a rate equal to or greater than the symbol rate, where each point represents the average power per sample, as estimated from the 200 arrays;
 - b2) the average power over the useful part of a burst as defined in EN 300 392-2 [1], ETS 300 393-2 [2], sampled at symbol rate at symbol time, further averaged over the 200 burst measurements. This single power value shall be used as the 0 dB reference for the power versus time profile determined in step b1) above.
- c) The steps a) and b) shall be repeated for the parameters detailed in test case 7. Under normal test conditions, on the middle radio frequency in the MS transmit band, the steps a) and b) shall be repeated for the parameters detailed in test cases 2 to 7.
- d) The test procedure above shall be performed on the lowest, highest and middle radio frequency channel in the MS transmit band.

8.1.2 BS transmitter output power

- a) The BS shall be connected to the test system and shall be set to test transmit mode. The BS shall operate in its normal mode i.e. continuous or discontinuous transmission and transmit at the BS maximum nominal output power level.
- b) The sampling system shall capture a representation of the BS transmit burst's amplitude and timing (excluding any BLCH transmissions by only capturing Normal Downlink Bursts with Normal Training Sequence 1, defined in EN 300 392-2 [1] clause 9). The procedure shall be repeated for 200 bursts and the test system shall calculate the following parameters:
 - b1) in the case of a discontinuous BS the average power versus time profile during time periods t_1 and t_3 (figure 7 in EN 300 392-2 [1]), extended at least 5 symbol periods before the start of t_1 and at least 5 symbol periods after the end of t_3 , sampled at a rate equal to or greater than the symbol rate, where each point represents the average power per sample, as estimated from the 200 arrays;
 - b2) the average power over the useful part of a burst as defined in EN 300 392-2 [1], ETS 300 393-2 [2], sampled at symbol rate at symbol time, further averaged over the 200 burst measurements. This single power value shall be used as the 0 dB reference for the power versus time profile determined in step b1) above.
- c) If applicable steps a) and b) shall be repeated at the BS minimum nominal power level.
- d) The tests shall be performed on the lowest, highest and middle radio frequency channel in the BS transmit band.

8.2 Unwanted output power in non active transmit state

The test shall be carried out at maximum nominal power level only under the normal test conditions specified in clause 6.

The procedure detailed in subclause 8.1.1 a) for MS or subclause 8.1.2 a) for discontinuous BS shall be used. The sampling system shall be used to measure the average unwanted transmitter output power during the non active time slots occurring between the successive burst transmissions of the MS or BS operating in discontinuous mode. The equipment under test shall transmit a burst only in one timeslot per frame and, hence each transmitted burst is followed by three non active time slots.

The test system shall calculate the average power over 200 non active time slots by applying the measurement procedure detailed in step b2) of subclause 8.1.1 for MS and subclause 8.1.2 for discontinuous BS to the active time slots, and by continuing to sample at a rate equal to or greater than the symbol rate during the whole non-active period of the non active time slots. The transmitter output power measured during active bursts shall be used as the 0dB reference for the unwanted output power in non active transmit state measured here. The test shall be performed on the lowest, highest and middle radio frequency channels of the equipment's transmit band.

8.3 Adjacent channel power due to modulation

The test shall be carried out at maximum and minimum nominal power levels only under normal and extreme (LTLV, HTHV) test conditions specified in clause 6. The procedure detailed in subclause 8.1.1 a) for MS and subclause 8.1.2 a) for BS shall be used. The sampling system shall be set to capture the transmit power (sampled at a rate equal to or greater than the symbol rate) appearing in the adjacent channels at the frequency offsets of ± 25 kHz, ± 50 kHz and ± 75 kHz from the nominal centre frequency of the allocated channel. The power measurements described here shall be timed to occur only during the useful part of Normal Uplink Bursts transmitted by the MS, or Normal Downlink Bursts with Normal Training Sequence 1 (to exclude any BLCH transmissions) transmitted by the BS, defined in EN 300 392-2 [1] clause 9.

For each adjacent channel, the test system shall calculate the average power by measuring, through the TETRA filter, the average power in the adjacent channel, sampled at a rate equal to or greater than the symbol rate, during the useful part of the burst in the allocated channel, further averaged over 200 burst measurements. The transmitter output power obtained by using the method described in subclause 8.1 shall be used as the 0 dB reference for the adjacent channel power measured here. The test shall be conducted in the middle radio frequency channel of the equipment's transmit band and in the case of MS equipment repeated as per table 15 test case 7 (minimum power level) and if applicable at the BS minimum power level.

8.4 Adjacent channel power due to switching transients

The test shall be carried out under the normal test conditions specified in clause 6. The procedure detailed in subclause 8.1.1 a) for MS or subclause 8.1.2 a) for BS shall be used. The measurement shall be conducted only in the middle radio frequency channel of the MS or discontinuous mode BS transmit band. This test is carried out at maximum nominal power only.

The test procedure is similar to that described in subclause 8.3, except that the measurement is performed only at a frequency offset of ± 25 kHz. In this case, the sampling system shall capture a representation of the adjacent channel power (sampled with a rate of at least 4 times the symbol rate) during the ramp-up and ramp-down periods (t_1 , t_3) of a burst transmitted by the equipment.

For each burst the test system shall record the peak power obtained. The procedure shall be repeated for 200 bursts and the results averaged. The transmitter output power obtained by using the method described in subclause 8.1 shall be used as the 0 dB reference for the adjacent channel power measured here.

8.5 Unwanted emissions far from the carrier

The tests shall be carried out under normal test conditions specified in clause 6. The procedure detailed in subclause 8.1.1 a) for MS or 8.1.2 a) for BS shall be used. The tests shall be performed at maximum nominal power level in the middle radio frequency channel only.

Discrete spurious:

Discrete spurious emissions shall be measured as the average power over at least 20 bursts, timed to occur only during the useful part of the burst and covering at least 200 symbols in each burst. The test system shall be connected to the antenna port of the equipment.

For frequency offsets greater than f_{rb} (where f_{rb} denotes the frequency offset corresponding to the near edge of the receive band or 5 MHz whichever is greater) a spectrum analyser with a resolution bandwidth according to table 16 shall be used.

Table 16: Measurement bandwidths

Measurement frequency	Resolution bandwidth	Video bandwidth (note 1)
9 kHz - 150 kHz	1 kHz	3 kHz
150 kHz - 30 MHz	10 kHz	30 kHz
30 MHz - 1 GHz (note 2)	100 kHz	300 kHz
1 GHz - 4 GHz	1 MHz	3 MHz
4 GHz - 12,75 GHz (note 3)	1 MHz	3 MHz
NOTE 1: When using a conventional swept frequency spectrum analyser.		
NOTE 2: Excluding frequencies within f_{rb} of the carrier.		
NOTE 3: Only for equipment capable of operating at frequencies greater than 470 MHz.		

For frequency offsets less than f_{rb} , the sampling system using a TETRA filter (described in subclause B.1.2) shall be used with a sample rate of at least 4 times the symbol rate. When a discrete spurious signal with a level greater than -36 dBm is detected, care must be taken to subtract the maximum permitted level of wideband noise at that frequency (see table 11) from the measured level before deciding whether it exceeds the specification.

A pre-scan may be performed to identify any potential discrete spurious emissions, using an appropriate technique.

Wideband noise:

Wideband noise level at selected frequency offsets from the on channel shall be measured through the TETRA filter (as defined in annex B). The selected frequency offsets shall cover at least 112,5 kHz, 262,5 kHz, 512,5 kHz and $f_{rb} + 12,5$ kHz where f_{rb} denotes the frequency offset corresponding to the near edge of the receive band or 5MHz whichever is greater. If a discrete spurious lies in one of these bands, then the closest discrete spurious free frequency which is higher shall be chosen. For each selected frequency offset the test system shall calculate the average power over at least 20 bursts, timed to occur only during the useful part of the burst and covering at least 200 symbols in each burst. The Tx output power obtained by using the method described in subclause 8.1 shall be used as the 0 dB reference for the unwanted emissions measured here.

8.6 Unwanted radiated emissions

The test shall be carried out under normal test conditions specified in clause 6. The test shall be performed at maximum nominal power level in the middle radio frequency channel only.

Using the measurement arrangement shown in ETS 300 113 [5] figure 9, on a test site fulfilling the requirements of ETS 300 113 [5] clause A.2, the MS or BS under test shall be placed at the specified height on the support. For BS testing, the test shall be carried out using an artificial antenna which shall be a substantially non-reactive non-radiating load of 50 Ω connected to the antenna connector. For MS testing, the test may be carried out using an artificial antenna which shall be a substantially non-reactive non-radiating load of 50 Ω connected to the antenna connector, or the test may be carried out with a non-radiating cable connecting the MS antenna connector to the test system, located outside the test site, in order to provide the T1 signal to the MS.

The MS or BS shall be operated in test transmit mode at maximum nominal power; the procedure detailed in subclause 8.1.1 a) for MS or 8.1.2 a) for BS may be used. Emissions from the cabinet of the MS or BS under test shall be received by the test antenna connected to the test receiver.

The radiation of any discrete spurious emissions in the range 30 MHz - 4 GHz, occurring at offsets equal to or greater than 100 kHz from the carrier frequency, shall be measured over 200 bursts as the peak power level of any discrete signal delivered to the test receiver connected to the test antenna. The resolution bandwidth of the measuring instrument shall be the smallest bandwidth available which is greater than the spectral width of the spurious component being measured. This shall be considered to be achieved when the next highest bandwidth causes less than 1 dB increase in amplitude.

At each frequency at which a discrete spurious emission is detected, the MS or BS under test shall be rotated to obtain maximum response and the effective radiated power of that component determined by a substitution measurement, using the measurement arrangement of ETS 300 113 [5] figure 10, where the substitution signal is T3.

The measurements shall be repeated with the test antenna in the orthogonal polarization plane.

A pre-scan may be performed to identify any potential discrete spurious emissions, using a suitable technique.

8.7 Unwanted emissions during the BLCH/CLCH (linearization)

The test shall be carried out under normal test and extreme (LTLV, HTHV) conditions specified in clause 6. The test shall be performed at maximum nominal power level in the middle radio frequency channel only, using the procedure detailed in subclause 8.1.1 a) for MS or subclause 8.1.2 a) for BS.

All normal transmissions from the equipment (excluding linearization bursts) shall meet the on-channel power requirements of subclause 7.1.1.2 and the adjacent channel power requirements of subclauses 7.1.3.2 and 7.1.4.2.

8.7.1 MS unwanted emissions during the CLCH (linearization)

Prior to any CLCH measurement the MS shall operate in the non-transmit (receive) state for a period of four minutes. Once the Tx_on parameter in the T1 BNCH/T information has been activated, only the transmitter emissions in the adjacent channel during the first CLCH period shall be measured.

For the CLCH measurement the sampling system shall be set to capture the transmit power appearing in either of the adjacent channels at the frequency offsets of ± 25 kHz from the nominal centre frequency of the allocated channel. The adjacent channel measurement shall be made using a TETRA filter. Appropriate triggering shall be used to capture the adjacent channel transmissions during the first CLCH period. The measurement instrument shall capture a 7,5 ms time record in order to provide the peak adjacent channel power (dBm) vs. time domain response of the signal. It is recommended that a sampling rate of at least 4 samples per symbol duration is used.

The measurement instrument provides a peak adjacent channel power "dBm" reading for CLCH period measured. To obtain a "dBc" reading the measured "dBm" value is then subtracted from the normal average on-channel "dBm" power level, as measured at maximum nominal power level in subclause 8.1 under the appropriate test conditions.

8.7.2 BS unwanted emissions during the BLCH (linearization)

Prior to any BLCH measurement, the BS shall be operating in BS test transmit mode as defined in subclause 5.2.2.3.

For the BLCH measurement the sampling system shall be set to capture the transmit power appearing in either of the adjacent channels at the frequency offsets of ± 25 kHz from the nominal centre frequency of the allocated channel. The adjacent channel measurement shall be made using a TETRA filter. The adjacent channel transmissions during a BLCH period shall be captured by timing the measurement to occur during block 2 of a Normal Downlink Burst with Normal Training Sequence 2, defined in EN 300 392-2 [1] clause 9. The measurement instrument shall capture a 6,0 ms time record in order to provide the peak adjacent channel power (dBm) vs. time domain response of the signal. It is recommended that a sampling rate of at least 4 samples per symbol duration is used.

The measurement instrument provides a peak adjacent channel power "dBm" reading for BLCH period measured. To obtain a "dBc" reading the measured "dBm" value is then subtracted from the normal average on-channel "dBm" power level, as measured at maximum nominal power level in subclause 8.1 under the appropriate test conditions.

8.8 Transmitter intermodulation attenuation

The test shall be carried out under normal test conditions specified in clause 6. Referring to the test configuration presented in subclause 5.1, the following equipment shall be employed:

- a spectrum analyser with 30 kHz measurement bandwidth as a power detecting device in frequency domain (annex B, subclause B.1.3) and an unmodulated signal generator as an interfering signal source (test signal T3, subclause 5.3.4). In addition, a directional coupler and RF attenuators shall be used to complete the measurement arrangement;
- using the procedure detailed in subclause 8.1.1 a) for MS and 8.1.2 a) for BS, the equipment under test shall be set to test transmit mode and transmit at its maximum nominal power level on the middle radio frequency channel. The interfering (unmodulated) signal generator shall be set to deliver the desired output power level detailed below, at a frequency of 500 kHz above the transmitter under test frequency. The frequency of signal T3 shall if necessary be adjusted in steps of 25 kHz such that the intermodulation components to be measured do not coincide with other spurious components. The spectrum analyser shall be used to measure the power of any intermodulation component occurring at offsets equal to or less than 10 MHz from the carrier frequency. The test shall be repeated with the T3 signal generator frequency set to 5 MHz above, 500 kHz below, and 5 MHz below the frequency of the transmitter under test.

8.8.1 MS Transmitter intermodulation attenuation

The signal generator level shall be set to deliver at the antenna connector of the transmitter under test an interfering signal (T3) at a power level 50 dB below the transmitter transmit level.

8.8.2 BS Transmitter intermodulation attenuation

The signal generator level shall be set to deliver at the antenna connector of the transmitter under test an interfering signal (T3) at a power level 30 dB below the transmitter transmit level.

8.8.3 Intra BS transmitter intermodulation attenuation

In the case of intra BS intermodulation, the individual transmitters shall be set to their nominal power levels and test signal T3 shall be switched off.

9 Methods of measurement for receiver parameters

9.1 General

Unless otherwise stated the equipment under test shall be operated in either the non-transmit state or the non-active transmit state.

9.2 Nominal error rates

The test shall be carried out under normal test conditions specified in clause 6. A test configuration as presented in subclause 5.1 should be applied. The equipment under test shall be connected to the test system via its antenna connector.

9.2.1 MS nominal error rate

- a) The V+D MS is set up to receive a T1 signal with channel type 1 burst in the middle radio frequency channel of the MS receive band. The propagation simulator function is set to TU50, defined in EN 300 392-2 [1] subclause 6.6.3.3. The test system shall transmit test signal T1 such that the power level at the antenna connector of the MS is -85 dBm.
- b) At the test connector the error events in the received data shall be captured and the appropriate BER shall be calculated (refer to clause A.2).
- c) Step b) shall be repeated with a power level of -20 dBm at the antenna connector of the MS under static channel conditions.

9.2.2 BS nominal error rate

- a) The V+D BS shall operate in its normal mode and shall transmit on timeslot 1 of frame 18 a synchronization burst containing BNCH/T information. The BNCH/T is used to indicate which channel type the BS expects the test system to send on timeslot 1 of the corresponding uplink channel in frames 1 to 18. A BS in continuous mode shall in time slots 1 to 4 of frames 1 to 17 and time slots 2 to 4 of frame 18, send a channel type 1 signal. For a discontinuous BS a channel type 1 signal shall be sent on timeslot 1 of frames 1 to 17 only.
- b) The BS is set up to receive a T1 signal with channel type 7 burst in the middle radio frequency channel of the BS receive band. The propagation simulator function is set to TU50, defined in EN 300 392-2 [1] subclause 6.6.3.3. The test system shall transmit test signal T1 such that the power level at the antenna connector of the BS is -85 dBm.
- c) At the test connector the error events in the received data shall be captured and the appropriate BER shall be calculated (refer to clause A.2).

- d) Step b) shall be repeated with a power level of -20 dBm at the antenna connector of the BS under static channel conditions.

9.3 Reference sensitivity performance

The test shall be carried out under normal and where applicable extreme (LTLV, HTHV) test conditions specified in clause 6. A test configuration as presented in subclause 5.1 should be applied. The equipment shall be connected to the test system via its antenna connector.

9.3.1 MS reference sensitivity performance

- a) Using test signal T1 the MS is set up to receive one of the logical channels defined in subclause 7.2.3. The propagation simulator function shall be set according to subclause 7.2.3. The test system shall provide the test signal T1, under normal test conditions, at a power level of -103 dBm.
- In order to reduce test time, only the V+D MS receiver sensitivity test using channel type 2, shall be conducted under both normal and extreme test conditions. Under extreme test conditions the test system shall provide the test signal T1, at a power level of -97 dBm. Channel type 2 receiver sensitivity measurements shall also be repeated in the highest, middle and lowest channels of the receive band. In all other V+D MS test cases the receiver sensitivity test shall only be performed in the middle channel of the receive band under normal conditions.
 - Only PDO MS receiver sensitivity tests using channel type 6, shall be repeated under both normal and extreme test conditions in the highest, middle and lowest channels of the receive band. Under extreme test conditions the test system shall provide the test signal T1, at a power level of -97 dBm. All other MS PDO receiver sensitivity testing, shall only be performed in the middle channel of the receive band under normal conditions.
- b) At the test connector the error events in the received data shall be captured and the appropriate error rate shall be calculated.
- c) Step b) shall be repeated for all test cases defined in subclause 7.2.3.

9.3.2 BS reference sensitivity performance

- a) Using the test set-up outlined in 9.2.2 the BS shall be set up to receive one of the logical channels defined in 7.2.3. The test system shall provide the test signal T1 at a power level of -106 dBm.
- In order to reduce test time, only the V+D BS receiver sensitivity test using channel type 8, shall be conducted under both normal and extreme test conditions. Under extreme test conditions the test system shall provide the test signal, at a power level of -100 dBm. Channel type 8 receiver sensitivity measurements shall also be repeated in the highest, middle and lowest channels of the receive band. In all other V+D BS test cases the receiver sensitivity test shall only be performed in the middle channel of the receive band under normal conditions.
 - Only PDO BS receiver sensitivity tests using channel type 12, shall be repeated under both normal and extreme test conditions in the highest, middle and lowest channels of the receive band. Under extreme test conditions the test system shall provide the test signal, at a power level of - 100 dBm. All other BS PDO receiver sensitivity testing, shall only be performed in the middle channel of the receive band under normal conditions.
- b) At the test connector the error events in the received data shall be captured and the appropriate error rate shall be calculated.
- c) Step b) shall be repeated for all test cases defined in subclause 7.2.3.

9.3.3 PUEM performance

The PUEM performance of the receiver under test at reference sensitivity shall be measured, the test cases and conditions are detailed in the PUEM test table in clause A.2. The receiver under test shall provide along with the recovered data a message error flag at the test connector. The test system shall record those instances when an message

error occurred, but the message error flag was not set. Following the completion of PUEM testing on the equipment, the test system shall generate a PUEM figure for each test case.

9.4 Reference interference performance

The tests shall be carried out under normal and in the case of adjacent channel interference, also extreme (LTLV, HTHV) test conditions specified in clause 6. A test configuration as presented in subclause 5.1 should be applied. The equipment shall be connected to the test system.

9.4.1 MS reference interference performance

- a) The MS is set up to receive one of the logical channels defined for co-channel interference in subclause 7.2.4 on a radio frequency channel in the middle of the MS receive band. The propagation simulator functions (for wanted and unwanted signals) shall be set according to subclause 7.2.4. The test system shall provide the test signal T1 (wanted signal at the nominal frequency of the MS receiver) with a power level of -85 dBm at the antenna connector of the MS.
- b) The interfering signal source shall provide the test signal T2 (unwanted signal) at the nominal frequency of the MS receiver and with a power level of -104 dBm at the antenna connector of the MS.
- c) At the test connector the error events in the received data shall be captured and the appropriate error rate calculated.
- d) Step c) shall be repeated for all co-channel interference test cases defined in subclause 7.2.4.
- e) The test system shall provide the wanted test signal T1 with a power level of -100 dBm (normal test conditions) or -94 dBm (extreme test conditions). The interfering signal source shall be set to provide the unwanted test signal T2 at the frequency offsets of ± 25 kHz from the nominal frequency of the MS receiver and with a power level of -55 dBm (normal) or -59 dBm (extreme).
- f) Step c) shall be repeated for all adjacent channel interference test cases defined in subclause 7.2.4.

9.4.2 BS reference interference performance

- a) Using the test set-up outlined in subclause 9.2.2 the BS shall be set up to receive one of the logical channels defined for co-channel interference in subclause 7.2.4 on a radio frequency channel in the middle of the BS receive band. The propagation simulator functions (for wanted and unwanted signals) shall be set according to subclause 7.2.4. The test system shall provide the test signal T1 (wanted signal at the nominal frequency of the BS receiver) with a power level of -85 dBm at the antenna connector of the BS.
- b) The interfering signal source shall provide the test signal T2 (unwanted signal) at the nominal frequency of the BS receiver and with a power level of -104 dBm at the antenna connector of the BS.
- c) At the test connector the error events in the received data shall be captured and the appropriate error rate calculated.
- d) Step c) shall be repeated for all co-channel interference test cases defined in subclause 7.2.4.
- e) The test system shall provide the wanted test signal at a power level of -103 dBm (normal test conditions) or -97 dBm (extreme test conditions). The interfering signal source shall be set to provide the unwanted test signal T2 at the frequency offsets of ± 25 kHz from the nominal frequency of the BS receiver and with a power level of -58 dBm (normal) or -62 dBm (extreme).
- f) Step c) shall be repeated for all adjacent channel interference test cases defined in subclause 7.2.4.

9.5 Blocking characteristics

The test shall be carried out under normal test conditions specified in clause 6. The test configuration presented in subclause 5.1 is applied. The error rate indication scheme used in subclauses 9.3 and 9.4 may be employed. All propagation simulator functions are set to "static". The equipment shall be connected to the test system.

9.5.1 MS blocking

- a) The MS is set up to receive a T1 channel type 1 signal (i.e. TCH/7,2 (NBCH for PDO)) on a radio frequency channel in the middle of the MS receive band. The test system shall provide the wanted test signal T1 at a power level of -109 dBm at the antenna connector of the MS.
- b) The interfering signal source shall provide the test signal T3 (unmodulated unwanted signal) at frequency offsets of approximately ± 1 MHz, ± 2 MHz, ± 5 MHz and ± 10 MHz from the nominal frequency of the MS receiver at a power level of -25 dBm. The actual values of the offset frequencies shall be adjusted in steps of 25 kHz such that they do not coincide with the frequencies of spurious response to be tested in subclause 9.6.
- c) For each of the offset frequencies chosen in step b) the bit error rate shall be indicated.

9.5.2 BS blocking

- a) Using the test set-up outlined in subclause 9.2.2 the BS shall be set up to receive a T1 channel type 7 for V+D BS or a channel type 11 for PDO BS, on a radio frequency channel in the middle of the BS receive band. The test system shall provide the wanted test signal T1 at a power level of -112 dBm at the antenna connector of the BS.
- b) The interfering signal source shall provide the test signal T3 (unmodulated unwanted signal) at frequency offsets of ± 1 MHz, ± 2 MHz, ± 5 MHz and ± 10 MHz from the nominal frequency of the BS receiver at a power level of -25 dBm. The actual values of the offset frequencies shall be adjusted in steps of 25 kHz such that they don't coincide with the frequencies of spurious response to be tested in subclause 9.6.
- c) For each of the offset frequencies chosen in step b) the bit error rate shall be indicated.

9.6 Spurious response rejection

The tests shall be carried out under the normal test conditions specified in clause 6. The tests shall be performed in the middle radio frequency channel only.

- a) The same test configuration and conditions as in subclause 9.5 with exceptions are applied. The frequency of the interfering signal is set to the frequencies as defined in clause A.1, and the power level of the interfering signal is set to the level specified in EN 300 392-2 [1], table 8: Blocking levels of the receiver. For each interfering frequency the error rate shall be measured. An interfering frequency where the blocking bit error rate limits in clause A.2 is not fulfilled is defined as a spurious response frequency.
- b) For each spurious response frequency the error rate shall be measured with a power level of the interfering signal of -45 dBm.
- c) For each of the spurious response frequencies found in step a) the frequency and bit error rate shall be indicated.

9.7 Intermodulation response rejection

The test shall be carried out under normal test conditions specified in clause 6. The test configuration presented in subclause 5.1 is applied. The error rate indication scheme used in subclauses 9.2 to 9.4 may be employed. All propagation simulator functions are set to "static". The equipment under test shall be connected to the test system.

9.7.1 MS intermodulation response rejection

- a) The MS is set up to receive a T1 channel type 1 signal (i.e. TCH/7,2 (NBCH for PDO)) on a radio frequency channel f_0 in the middle of the MS receive band. The test system shall provide the wanted test signal T1 at a power level of -109 dBm at the antenna connector of the MS.
- b) The unmodulated interfering signal source shall provide the test signal T3 (unmodulated unwanted signal) at frequency ($f_1 = f_0 - 200$ kHz) and with a power level of -47 dBm. The modulated interfering signal source shall provide the test signal T2 (modulated unwanted signal) at frequency ($f_2 = f_0 - 400$ kHz) and with a power level of -47 dBm. Both unwanted power levels refer to the antenna connector of the MS.

- c) The error events in the received data shall be captured and the appropriate error rate shall be calculated.
- d) Step c) shall be repeated with the unwanted signal frequencies set to ($f_1 = f_0 + 200$ kHz) and ($f_2 = f_0 + 400$ kHz).

9.7.2 BS intermodulation response rejection

- a) Using the test set-up outlined in subclause 9.2.2 the BS shall be set up to receive a T1 channel type 7 for V+D BS or a channel type 11 for PDO BS, on a radio frequency channel f_0 in the middle of the BS receive band. The test system shall provide the wanted test signal T1 at a power level of -112 dBm at the antenna connector of the BS.
- b) The unmodulated interfering signal source shall provide the test signal T3 (unmodulated unwanted signal) at frequency ($f_1 = f_0 - 200$ kHz) and with a power level of -47 dBm. The modulated interfering signal source shall provide the test signal T2 (modulated unwanted signal) at frequency ($f_2 = f_0 - 400$ kHz) and with a power level of -47 dBm. Both unwanted power levels refer to the antenna connector of the BS.
- c) The error events in the received data shall be captured and the appropriate error rate shall be calculated.
- d) Step c) shall be repeated with the unwanted signal frequencies set to ($f_1 = f_0 + 200$ kHz) and ($f_2 = f_0 + 400$ kHz).

9.8 Unwanted emissions

The test shall be carried out under normal test conditions specified in clause 6.

The equipment shall be connected to the test system via its antenna connector. The equipment shall be in receive mode in the non-transmit state. For equipment only capable of operating at frequencies below 470 MHz, the test system shall measure the peak power emitted by the equipment in the frequency range 9 kHz to 4 GHz. For equipment capable of operating at frequencies above 470 MHz, the test system shall measure the peak power emitted by the equipment in the frequency range 9 kHz to 12,75 GHz. Discrete spurious emissions shall be measured as a peak power level of any discrete signal delivered to a spectrum analyser suitably connected to the antenna port of the equipment (defined in subclause B.1.3). The resolution bandwidth of the spectrum analyser shall be 100 kHz for frequencies up to 1 GHz and 1 MHz for frequencies above 1 GHz. When measuring in the frequency range below 3 MHz the measurement bandwidth shall be reduced according to specifications of the spectrum analyser. The test shall be performed on the middle radio frequency channel only of the equipment's receive band.

9.9 Unwanted radiated emissions

The test shall be carried out under normal test conditions specified in clause 6. The test shall be performed with the equipment in receive mode in the non-transmit state in the middle radio frequency channel only.

Using the measurement arrangement shown in ETS 300 113 [5] figure 9, on a test site fulfilling the requirements of ETS 300 113 [5] clause A.2, the MS or BS under test shall be placed at the specified height on the support. For BS testing, the test shall be carried out using an artificial antenna which shall be a substantially non-reactive non-radiating load of 50 Ω connected to the antenna connector. For MS testing, the test may be carried out using an artificial antenna which shall be a substantially non-reactive non-radiating load of 50 Ω connected to the antenna connector, or the test may be carried out with a non-radiating cable connecting the MS antenna connector to the test system, located outside the test site, in order to provide the T1 signal to the MS.

The MS or BS shall be operated in test receive mode in the non-transmit state. Emissions from the cabinet of the MS or BS under test shall be received by the test antenna connected to the test receiver.

The radiation of any discrete spurious emissions in the range 30 MHz to 4 GHz, occurring at offsets equal to or greater than 100 kHz from the carrier frequency, shall be measured over 200 bursts as the peak power level of any discrete signal delivered to the test receiver connected to the test antenna. The resolution bandwidth of the measuring instrument shall be the smallest bandwidth available which is greater than the spectral width of the spurious component being measured. This shall be considered to be achieved when the next highest bandwidth causes less than 1 dB increase in amplitude.

At each frequency at which a discrete spurious emission is detected, the MS or BS under test shall be rotated to obtain maximum response and the effective radiated power of that component determined by a substitution measurement, using the measurement arrangement of ETS 300 113 [5] figure 10, where the substitution signal is T3.

The measurements shall be repeated with the test antenna in the orthogonal polarization plane.

A pre-scan may be performed to identify any potential discrete spurious emissions, using a suitable technique.

10 Methods of measurement for transmitter/receiver parameters

10.1 Modulation accuracy

The test shall be carried out at maximum nominal power only under normal test conditions specified in clause 6. The measurements described here are performed, in the case of MS equipment on Normal Uplink Bursts or in the case of BS equipment Normal Downlink Bursts with Normal Training Sequence 1 (to exclude any BLCH transmissions), defined in EN 300 392-2 [1], clause 9, EN 300 393-2 [2]. The test configuration presented in subclause 5.1 is applied. The sampling system in subclause B.1.2 shall be employed.

10.1.1 MS modulation accuracy

The MS shall be connected to the test system. The test system shall transmit test signal T1. Test signal T1 BNCH/T(V+D) or MBCH/T(PDO) parameters and level as detailed in test case 1 of subclause 8.1.1 a) shall be used. All T1 levels are referenced to the antenna connector of the MS.

The MS shall be set to test receive mode for a period of at least 5 seconds in which it will decode BSCH and BNCH/T(V+D) or MBCH/T(PDO) information and measure T1 signal strength. The MS shall then be set to test transmit mode. The modulation accuracy shall be tested by measuring the vector error magnitude as specified in subclause 10.1.3.

10.1.2 BS modulation accuracy

The BS shall be connected to the test system. The test procedure detailed in subclause 8.1.2 a) shall be used. The modulation accuracy shall be tested by measuring the vector error magnitude as specified in subclause 10.1.3.

10.1.3 Vector error magnitude at symbol time

- a) The sampling system shall capture a representation of the transmit burst's vector error at sampling times t_k (symbol by symbol) where t_k is the symbol time corresponding to the k^{th} symbol. For each symbol the sampling system shall compute the vector error $Z'(k)-S(k)$ defined in EN 300 392-2 [1], clause 6, where $Z'(k)$ is the normalized modulation symbol transmitted by the MS and $S(k)$ is the modulation symbol which would be transmitted by an ideal MS. The sampling system shall calculate the RMS vector error RMSVE for all symbols of the burst as defined in EN 300 392-2 [1], clause 6. The sampling system shall also calculate the peak vector error magnitude $|Z'(k)-S(k)|$ and the residual carrier magnitude C_0 as defined in EN 300 392-2 [1], clause 6 for each symbol of the burst and shall calculate the mean residual carrier magnitude $\langle C_0 \rangle$ averaged over all values C_0 of the burst.
- b) The procedure described in step a) shall be repeated for 200 bursts.
- c) The procedures described in steps a) and b) shall be performed on the lowest, highest and middle radio frequency channel in the transmit band.

10.2 Carrier frequency accuracy

The test set-up shall be according to subclause 10.1.

10.2.1 MS carrier frequency accuracy

The sampling system shall be synchronized to the internal timing reference of the test system. The MS shall adjust its frequency by means of BSCH signals received from the test system. The MS shall be connected to the test system and the test system shall transmit test signal T1. Test signal T1 level and BNCH/T(V+D) or MBCH/T(PDO) parameters as detailed in test case 1 of subclause 8.1.1 a) shall be used. All T1 levels are referenced to the antenna connector of the MS.

The MS shall be set to test receive mode for a period of at least 5 seconds in which it will decode BSCH and BNCH/T(V+D) or MBCH/T(PDO) information and measure T1 signal strength. The MS shall then be set to test transmit mode and the input level applied to the MS shall be the static reference sensitivity level.

- a) The sampling system shall capture a representation of the MS transmit burst's modulation symbol $Z(k)$ at sampling times t_k (symbol by symbol) where t_k is the symbol time corresponding to the k^{th} symbol. For each symbol the sampling system shall measure the phase rotation θ which is caused by the frequency difference between the MS and the sampling system, as defined in EN 300 392-2 [1], clause 6. The sampling system shall calculate the frequency error (df) for the burst as follows:

$$df = 1/(2\pi T \text{SNmax}) \sum_{k=1}^{\text{SNmax}} \theta(k)$$

where df is expressed in Hz, T is the symbol duration in s, $\theta(k)$ is expressed in radians, and SNmax is the number of symbols in a burst.

- b) The procedure described in step a) shall be repeated for 20 bursts.
- c) The procedures described in steps a) and b) shall be performed on the lowest, highest and middle radio frequency channel in the MS transmit band.

10.2.2 BS carrier frequency accuracy

The BS shall be connected to the test system. The test procedure detailed in subclause 8.1.2 a) shall be used. The carrier frequency accuracy shall be tested as follows.

- a) The sampling system shall capture a representation of the BS transmit burst's modulation symbol $Z(k)$ at sampling times t_k (symbol by symbol) where t_k is the symbol time corresponding to the k^{th} symbol. For each symbol the sampling system shall measure the phase rotation θ which is caused by the frequency difference between the BS and the sampling system, as defined in EN 300 392-2 [1], clause 6. The sampling system shall calculate the frequency error df for the burst as follows:

$$df = 1/(2\pi T \text{SNmax}) \sum_{k=1}^{\text{SNmax}} \theta(k)$$

where df is expressed in Hz, T is the symbol duration in s, $\theta(k)$ is expressed in radians, and SNmax is the number of symbols in a burst.

- b) The procedure described in step a) shall be repeated for 20 bursts.
- c) If applicable the procedures described in steps a) and b) shall be performed on the lowest, highest and middle radio frequency channel in the BS transmit band.

10.3 MS receiver performance for synchronization burst acquisition

The test shall be carried out under normal test conditions specified in clause 6. A test configuration as presented in subclause 5.1 may be applied. The propagation simulator function (wanted signal only) shall be set to TU50 for class B receiver testing and HT200 for class A and class E receiver testing, defined in EN 300 392-2 [1] subclause 6.6.3.3. The test system shall transmit discontinuous synchronization bursts (channel type 13 for V+D, channel type 14 for PDO) on

the middle frequency of the receive band, at a power level of - 103 dBm. Before starting the synchronization burst acquisition performance test the MS shall be switched off for a period of at least 60 seconds, following power on the MS receiver shall be fixed to the middle frequency channel of the receive band, i.e. no scanning required. The MS will now attempt to detect the synchronization burst and decode the BSCH and BNCH/T (V+D) or MBCH/T(PDO) information. A special T1_burst_type field contained in the BNCH/T or MBCH/T, is used to place the MS into synchronization acquisition test mode. During this period the MS may perform some frequency offset correction.

Following the first synchronization burst which is successfully detected and decoded, the MS shall enter synchronization acquisition test mode, this shall be immediately indicated at the test connector to inform the test system that the MS is ready for the synchronization burst acquisition test.

Once in synchronization acquisition mode the MS shall continuously attempt to detect a synchronization burst and decode the BSCH information. Each successful decoding shall be indicated at the MS test connector.

The test system shall transmit 20 synchronization bursts and count the number of successful acquisitions and calculate the PACQ.

10.4 MS Frame alignment performance

The test shall be carried out under normal test conditions specified in clause 6. A test configuration as presented in subclause 5.1 may be applied. The training sequences transmitted by the test system shall be used as a timing reference during this test procedure. The MS shall be synchronized to the test system (in terms of frequency and time slot).

The test system shall transmit test signal T1 on a frequency in the middle of the MS receive band, at 3 dB below the dynamic reference sensitivity level, placing the MS into test transmit mode.

- a) The propagation simulator function (T1, wanted signal only) is set to TU50 (class B) or HT200 (class A, class E), defined in EN 300 392-2 [1] subclause 6.6.3.3.
- b) The timing delay (TD) of bursts transmitted by the test system shall be set to zero (symbol durations).
- c) The MS shall transmit normal uplink bursts in the radio frequency channel in the middle of the MS transmit band. The timing measurement unit (refer to subclause B.1.7) shall compare the timing of each burst received from the MS with that of the slot timing of test signal T1. The timing measurement shall be repeated for 200 bursts.
- d) The test system shall increase the delay (TD) of its transmission in steps of one symbol duration . After setting a new delay value (TD) a settling time of 10s is required for the MS before starting the next timing measurement. The step c) above shall be repeated for TD values of 1, 2 and 3 symbol durations.

10.5 MS link control

The test shall be carried out under normal test conditions specified in clause 6.

- a) The MS shall be connected to the test system. The test system shall transmit test signal T1. Test signal T1 level and BNCH/T(V+D) or MBCH/T(PDO) parameters as detailed in test case 1 in table 17 shall be used. All T1 levels are referenced to the antenna connector of the MS.

Table 17: Test Case

test case	T1 level dBm	Access_parameter dBm	MS_TXPWR_MAXCELL dBm	maximum power dBm
1	-80	-53	45	32,5
2	-65	-53	45	17,5
3	-50	-33	45	22,5

- The MS shall be set to test receive mode for a period of at least 5 seconds in which it will decode BSCH and BNCH/T(V+D) or MBCH/T(PDO) information and measure T1 signal strength. The MS shall then be set to test transmit mode.

- b) The sampling system shall capture a representation of the MS transmit burst's (excluding any CLCH transmissions) amplitude and timing (sampled at symbol rate at symbol time). The procedure shall be repeated for 200 bursts and the test system shall calculate the average power over the useful part of a burst as defined in EN 300 392-2 [1], ETS 300 393-2 [2], further averaged over the 200 burst measurements.
- c) The steps a) and b) shall be repeated for the parameters detailed in test cases 2 and 3.
- d) The test shall be performed on the lowest, highest and middle radio frequency channels in the MS receive band.

The test scenario presented in figure 2 is applied. The propagation simulator function (wanted signal only) shall be set to TU50, defined in EN 300 392-2 [1] subclause 6.6.3.3.

NOTE: The dynamic propagation condition TU50 is used in order to test implicitly the capability of the MS to perform averaged signal strength measurements under the "fading" reception conditions.

The test system shall know the maximum MS power.

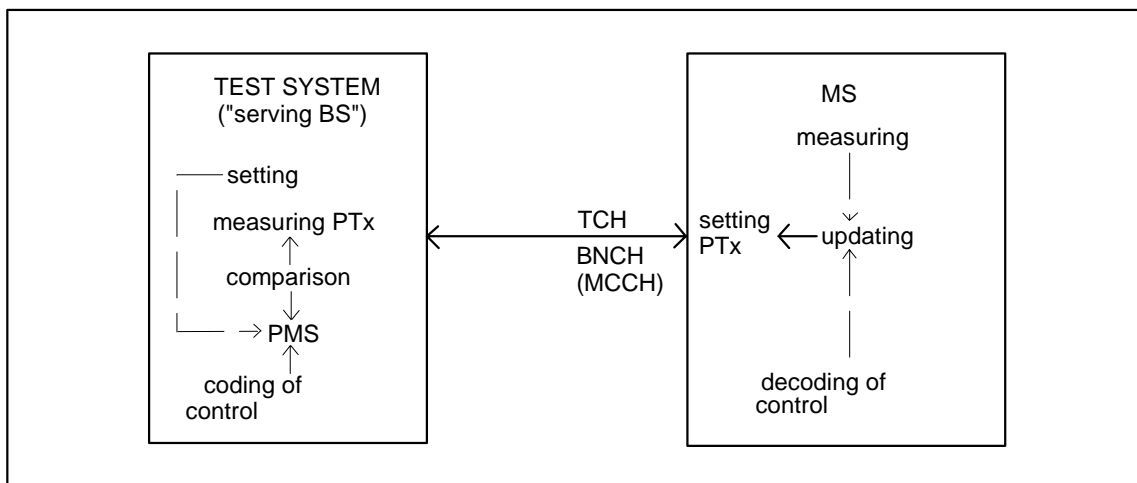

Figure 2: MS link control test scenario

11 Measurement uncertainty

The maximum acceptable uncertainty of measurement equipment is specified separately for each test, where appropriate. The measurement equipment shall enable the stimulus signals in the test case to be adjusted to within the specified tolerance, and the conformance requirement to be measured with an uncertainty not exceeding the specified values. All tolerances and uncertainties are absolute values, unless otherwise stated. All test case tolerances and measurement uncertainties are specified through the TETRA filter, unless otherwise stated.

Clause 6, Test conditions:

Temperature	± 2 degrees
Relative Humidity	± 5 %
DC Voltage	$\pm 1,0$ %
AC Voltage	$\pm 1,5$ %

The above values shall apply unless the test environment is controlled and the specification for the control of the test environment specifies the uncertainty for the parameter.

11.1 Transmitter

Subclause 8.1.1, MS Mean transmitted RF carrier power:

Test case:

T1 level $\pm 3,0$ dB

Conformance requirement:

RF power $\pm 0,75$ dB

Subclause 8.1.1, MS Transmitted RF carrier power versus time:

Test case:

T1 level $\pm 3,0$ dB

Inherent noise level:

RF power (L_{\min}) ≤ -80 dBc

Conformance requirement:

RF power relative to 0 dB reference (0 dBc to -45 dBc) $\pm 1,0$ dB

RF power relative to 0 dB reference (< -45 dBc to -73 dBc) $\pm 1,5$ dB

Timing uncertainty (profile) $\pm 1/16$ symbol

Subclause 8.1.2, BS Mean transmitted RF carrier power:

Test case:

T1 level $\pm 3,0$ dB

Conformance requirement:

RF power $\pm 0,75$ dB

Subclause 8.1.2, BS transmitted RF carrier power versus time:

Test case:

T1 level $\pm 3,0$ dB

Inherent noise level:

RF power (L_{\min}) ≤ -50 dBc

Conformance requirement:

RF power relative to 0 dB reference (0 dBc to -45 dBc) $\pm 1,0$ dB

RF power relative to 0 dB reference (< -45 dBc to -73 dBc) $\pm 1,5$ dB

Timing uncertainty (profile) $\pm 1/16$ symbol

Subclause 8.2, Unwanted output power in non-active transmit state:

Test case:

T1 level $\pm 3,0$ dB

Conformance requirement:

RF power relative to 0 dB reference (0 dBc to -45 dBc) $\pm 1,0$ dB

RF power relative to 0 dB reference (< -45 dBc to -73 dBc) $\pm 1,5$ dB

Inherent noise level ≤ -80 dBc

Subclause 8.3, Adjacent channel power due to modulation :

Test case:

T1 level $\pm 3,0$ dB

Maximum residual adjacent channel level of the test system:

Maximum level at frequency offset 25 kHz -70 dBc

Maximum level at frequency offset 50 kHz -80 dBc

Maximum level at frequency offset 75 kHz -80 dBc

Conformance requirement:

RF power (0 dB reference) $\pm 1,0$ dB

RF power relative to 0 dB reference (0 dBc to -45 dBc) $\pm 1,0$ dB

RF power relative to 0 dB reference (< -45 dBc to -73 dBc) $\pm 1,5$ dB

RF power (absolute limit values) $\pm 1,0$ dB

Subclause 8.4, Adjacent channel power due to switching transients:

Test case:

T1 level $\pm 3,0$ dB

Maximum residual adjacent channel level of the test system:

Maximum level at frequency offset 25 kHz -60 dBc

Conformance requirement:

RF power (0 dB reference) $\pm 1,0$ dB

RF power relative to 0 dB reference (0 dBc to -45 dBc) $\pm 1,0$ dB

RF power relative to 0 dB reference (< -45 dBc to -53 dBc) $\pm 1,5$ dB

Subclause 8.5, Unwanted emissions far from the carrier; a) discrete spurious:

Test case:

T1 level $\pm 3,0$ dB

Conformance requirement:

RF power (offsets within f_{tb}) $\pm 1,5$ dB

RF power (offsets > f_{tb} , not TETRA filtered):

$f \leq 1$ GHz $\pm 1,5$ dB

1 GHz < $f \leq 2$ GHz $\pm 2,0$ dB

2 GHz < f ≤ 4 GHz ±3,0 dB

4 GHz < f ≤ 12,75 GHz ±4,0 dB

Subclause 8.5, Unwanted emissions far from the carrier; b) wideband noise:

Test case:

T1 level ±3,0 dB

Conformance requirement:

RF power relative to 0 dB reference (0 dBc to -45 dBc) ±1,0 dB

RF power relative to 0 dB reference (< -45 dBc to -105 dBc) ±1,5 dB

Subclause 8.6, Unwanted radiated emissions:

Test case:

T1 level (conducted) ±3,0 dB

Conformance requirement:

RF power (not TETRA filtered) ±4,0 dB

Subclause 8.7, Unwanted emissions during the BLCH/CLCH (linearization):

Test case:

T1 level ±3,0 dB

Conformance requirement:

RF power (0 dB reference) ±1,0 dB

RF power relative to 0 dB reference (0 dBc to -45 dBc) ±1,0 dB

RF power relative to 0 dB reference (< -45 dBc to -73 dBc) ±1,5 dB

Subclause 8.8, Tx intermodulation attenuation

Test case:

T1 level ±3,0 dB

T3 level (not TETRA filtered), relative to RF power ±1,0 dB

Conformance requirement:

RF power (0 dB reference) ±1,0 dB

RF power (note) relative to 0 dB reference (0 dBc to -45 dBc) ±1,0 dB

RF power (note) relative to 0 dB ref. (< -45 dBc to -73 dBc) ±1,5 dB

NOTE: Not TETRA filtered.

11.2 Receiver

Where a measurement uncertainty of $\pm x, x$ dB / $-0,0$ dB is specified for an input signal, the measured value of the input signal should be increased by an amount equal to the uncertainty with which it can be measured. This will ensure that the true value of the input signal is not below the specified nominal.

Subclause 9.2, Nominal error rates:

Test case:

T1 level, static	$\pm 1,0$ dB
T1 level, dynamic	$\pm 1,5$ dB

Subclause 9.3, Reference sensitivity performance:

Test case:

T1 level, dynamic	$+3,0$ dB / $-0,0$ dB
-------------------	-----------------------

Subclause 9.4, Reference interference performance:

Test case:

T1 level, dynamic	$+3,0$ dB / $-0,0$ dB
T2 level, static, relative to T1	$\pm 1,0$ dB
T2 level, dynamic, relative to T1	$\pm 1,5$ dB

Subclause 9.5, Blocking characteristics:

Test case:

T1 level, static	$+2,0$ dB / $-0,0$ dB
T3 level (not TETRA filtered)	$\pm 1,0$ dB

T3 noise level (not TETRA filtered):

- the interferer shall be of adequate noise performance to enable the test to be performed so that its noise does not increase the noise level at the antenna connector by more than $1,0$ dB. This may require the use of additional filters to prevent an increase in the noise at the antenna connector.

Subclause 9.6, Spurious response rejection:

Test case:

T1 level, static	$+2,0$ dB / $0,0$ dB
T3 level (not TETRA filtered):	
$f \leq 1$ GHz	$\pm 1,0$ dB
1 GHz $< f \leq 2$ GHz	$\pm 1,5$ dB
$f > 2$ GHz	$\pm 2,0$ dB

T3 noise level (not TETRA filtered):

- the interferer shall be of adequate noise performance to enable the test to be performed so that its noise does not increase the noise level at the antenna connector by more than $1,0$ dB. This may require the use of additional filters to prevent an increase in the noise at the antenna connector.

Subclause 9.7, Intermodulation response rejection:

Test case:

T1 level, static	+2,0 dB / -0,0 dB
T2 level, static	±1,0 dB
T3 level (not TETRA filtered)	±1,0 dB

T3 noise level (not TETRA filtered) and T2 noise level:

- the interferers shall be of adequate noise performance to enable the test to be performed so that their noise does not increase the noise level at the antenna connector by more than 1,0 dB. This may require the use of additional filters to prevent an increase in the noise at the antenna connector.

Subclause 9.8, Unwanted conducted emissions:

Conformance requirement:

RF power (not TETRA filtered):

$f \leq 1\text{GHz}$	±1,5 dB
$1\text{ GHz} < f \leq 2\text{ GHz}$	±2,0 dB
$2\text{ GHz} < f \leq 4\text{ GHz}$	±3,0 dB
$4\text{ GHz} < f \leq 12,75\text{ GHz}$	±4,0 dB

Subclause 9.9, Unwanted radiated emissions:

Test case:

T1 level (conducted)	±3,0 dB
----------------------	---------

Conformance requirement:

RF power (not TETRA filtered)	±4,0 dB
-------------------------------	---------

11.3 Transmitter/receiver parameter definitions & limits

Subclause 10.1, Modulation accuracy:

Test case:

T1 level $\pm 3,0$ dB

Conformance requirement:

RMS vector error $\pm 1,0$ %

peak vector error $\pm 3,0$ %

Residual carrier magnitude $\pm 1,0$ %

Subclause 10.2, Carrier frequency accuracy:

Test case:

T1 level $\pm 3,0$ dB

Conformance requirement:

Frequency $300 \text{ MHz} \leq f \leq 520 \text{ MHz}$ $\pm 0,02$ ppm

Frequency $520 \text{ MHz} < f \leq 1 \text{ GHz}$ $\pm 0,01$ ppm

Subclause 10.3, MS receiver performance for synchronization burst acquisition:

Test case

T1 level, dynamic $+3,0$ dB / $-0,0$ dB

Subclause 10.4, MS Frame alignment performance:

Test case:

T1 level, dynamic $+3,0$ dB / $-0,0$ dB

Conformance requirement:

Timing uncertainty $\pm 1/16$ symbol

Subclause 10.5, MS link control:

Test case:

T1 level, dynamic $\pm 1,5$ dB

Conformance requirement:

RF power $\pm 0,75$ dB

11.4 Interpretation of measurement results

The measurement value related to the corresponding limit shall be used to decide whether an equipment meets a requirement in the present document. The measurement uncertainty for the measurement of each parameter shall be included in the test report. The recorded value for the measurement uncertainty shall be, for each measurement, equal to or lower than the appropriate figure in clause 11 of the present document.

NOTE: This procedure is recommended in ETR 028 [4].

Annex A (normative): TETRA receiver testing

A.1 Frequencies of spurious response

Annex A provides a definition of the interfering frequencies which are used during measurement of the spurious response rejection.

The interfering frequencies which are used during measurement of the spurious response rejection are defined as the combined frequencies of two sets of frequencies:

- a) All frequencies (f_l) in integer steps of 6,25 kHz within the limited frequency range:

$$f_{lo} - \sum_{j=1}^n f_{ij} - sr/2 \leq f_l \leq f_{lo} + \sum_{j=1}^n f_{ij} + sr/2$$

- Where (sr) is the switching range of the receive band of the equipment, (f_{lo}) is the frequency of the local oscillator signal applied to the first mixer of the receiver and (f_{i1}, \dots, f_{in}) is the intermediate frequencies of the receiver.
- b) The discrete frequencies at which spurious response can occur outside the range determined in a) above for the remainder of the frequency range of interest up to 4 GHz determined as $nf_{lo} \pm f_{i1}$ and $pf_r \pm f_{i1}$, where n is an integer greater than or equal to 2, p is an integer greater than or equal to 1, (f_r) is the frequency of any other oscillator used to generate reference frequencies in the receiver and (f_{i1}) is the first intermediate frequencies of the receiver.

For the calculations a) and b) above, the manufacturer shall state the frequency of the receiver (f_o), the frequency of the local oscillator signal (f_{lo}) applied to the 1st mixer of the receiver, the frequency (f_r) of any other oscillator used to generate reference frequencies in the receiver, the intermediate frequencies (f_{i1}, \dots, f_{in}) and the switching range (sr) of the receiver.

A.2 Test cases and test conditions for BS and MS receivers

Annex A contains receiver test tables for TETRA BS and MS equipment for both V+D and PDO applications. The tables list test type and provide information on channel type used in each test, test limits, minimum sample size and signal levels. Only in the case where a MS or BS supports protected circuit mode data shall the TCH/2,4 receiver sensitivity measurements be conducted. Test specifications and limits which are underscored indicate a BER measurement and those which are not, are MER measurements. For those tests measured under both normal and extreme test conditions, signal levels under extreme test conditions are shown in brackets, "()". Test tables for PUEM measurements are given at the end of the annex. The propagation models specified (TU50, HT200, EQ200) are defined in EN 300 392-2 [1] subclause 6.6.3.3.

Table A.1: Test conditions for MS receiver V+D, class A

Test type	Channel type	Logical channel	Propagation condition	Signal level (dBm)	Interferer level (dBm)	Spec. BER or MER %	Test limit BER or MER %	Minimum sample size
nominal error	1	TCH/7,2	TU50	-85		<u>0,4</u>	<u>0,448</u>	3,6E6
nominal error	1	TCH/7,2	STAT	-20		<u>0,1</u>	<u>0,122</u>	170 000
sensitivity	2	SCH/F	TU50	-103 (-97)		8	8,96	6 600
sensitivity	2	AACH	TU50	-103 (-97)		10	11,2	6 600
sensitivity	3	BSCH	HT200	-103		11	12,32	4 800
sensitivity	3	SCH/HD	HT200	-103		11	12,32	4 800
sensitivity	4	AACH	HT200	-103		17	19,04	3 000
sensitivity	4	TCH/2,4 N = 1	HT200	-103		<u>1,1</u>	<u>1,232</u>	1,29E6
co-channel interference	2	SCH/F	HT200	-85	-104	9,2	10,304	7 000
adjacent channel interference	2	SCH/F	TU50	-100 (-94)	-55 (-59)	6,5	7,280	8 000
inter-modulation	1	TCH/7,2	STAT	-109	-47	<u>3,5</u>	<u>4,270</u>	5 000
blocking	1	TCH/7,2	STAT	-109	-25	<u>3,5</u>	<u>4,270</u>	5 000
spurious response	1	TCH/7,2	STAT	-109	-45	<u>3,5</u>	<u>4,270</u>	5 000

Table A.2: Test conditions for MS receiver V+D, class B

Test type	Channel type	Logical channel	Propagation condition	Signal level (dBm)	Interferer level (dBm)	Spec. BER or MER %	Test limit BER or MER %	Minimum sample size
nominal error	1	TCH/7,2	TU50	-85		<u>0,4</u>	<u>0,448</u>	3,6E6
nominal error	1	TCH/7,2	STAT	-20		<u>0,1</u>	<u>0,122</u>	170 000
sensitivity	2	SCH/F	TU50	-103 (-97)		8	8,96	6 600
sensitivity	2	AACH	TU50	-103 (-97)		11	12,32	6 600
sensitivity	3	BSCH	TU50	-103		8	8,96	6 600
sensitivity	3	SCH/HD	TU50	-103		8	8,96	6 600
sensitivity	4	AACH	TU50	-103		11	12,32	5 000
sensitivity	4	TCH/2,4 N = 1	TU50	-103		<u>0,35</u>	<u>0,392</u>	2,16E6
co-channel interference	2	SCH/F	TU50	-85	-104	6,5	7,280	8 500
adjacent channel interference	2	SCH/F	TU50	-100 (-94)	-55 (-59)	6,5	7,280	8 000
inter-modulation	1	TCH/7,2	STAT	-109	-47	<u>4</u>	<u>4,880</u>	4 500
blocking	1	TCH/7,2	STAT	-109	-25	<u>4</u>	<u>4,880</u>	4 500
spurious response	1	TCH/7,2	STAT	-109	-45	<u>4</u>	<u>4,880</u>	4 500

Table A.3: Test conditions for MS receiver V+D, class E

Test type	Channel type	Logical channel	Propagation condition	Signal level (dBm)	Interferer level (dBm)	Spec. BER or MER %	Test limit BER or MER %	Minimum sample size
nominal error	1	TCH/7,2	TU50	-85		<u>0,4</u>	<u>0,448</u>	3,6E6
nominal error	1	TCH/7,2	STAT	-20		<u>0,1</u>	<u>0,122</u>	170 000
sensitivity	2	SCH/F	TU50	-103 (-97)		8	8,96	6 600
sensitivity	2	AACH	TU50	-103 (-97)		10	11,2	6 600
sensitivity	3	BSCH	EQ200	-103		22	24,64	2 000
sensitivity	3	SCH/HD	EQ200	-103		21	23,52	2 000
sensitivity	4	AACH	EQ200	-103		16	17,92	3 000
sensitivity	4	TCH/2,4 N = 1	EQ200	-103		<u>0,82</u>	<u>0,918</u>	1,29E6
co-channel interference	2	SCH/F	EQ200	-85	-104	20	22,400	3 500
adjacent channel interference	2	SCH/F	TU50	-100 (-94)	-55 (-59)	6,5	7,280	8 000
inter-modulation	1	TCH/7,2	STAT	-109	-47	<u>3,5</u>	<u>4,270</u>	4 500
blocking	1	TCH/7,2	STAT	-109	-25	<u>3,5</u>	<u>4,270</u>	4 500
spurious response	1	TCH/7,2	STAT	-109	-45	<u>3,5</u>	<u>4,270</u>	4 500

Table A.4: Test conditions for MS receiver PDO, class A

Test type	Channel type	Logical channel	Propagation condition	Signal level (dBm)	Interferer level (dBm)	Spec. MER %	Test limit MER %	Minimum sample size
sensitivity	6	NBCH	HT200	-103		11	12,32	4 500
sensitivity	5	MBCH	HT200	-103		11	12,32	4 500
sensitivity	6	NBCH	TU50	-103 (-97)		8	8,96	6 500
sensitivity	5	MBCH	TU50	-103 (-97)		8	8,96	6 500
co-channel interference	6	NBCH	TU50	-85	-104	7	7,84	9 000
co-channel interference	5	MBCH	TU50	-85	-104	6	6,720	9 000
adjacent channel interference	6	NBCH	TU50	-100 (-94)	-55 (-59)	7	7,84	9 000
inter-modulation	6	NBCH	STAT	-109	-47	2,5	3,050	6 500
blocking	6	NBCH	STAT	-109	-25	2,5	3,050	6 500
spurious response	6	NBCH	STAT	-109	-45	2,5	3,050	6 500

Table A.5: Test conditions for MS receiver PDO, class B

Test type	Channel type	Logical channel	Propagation condition	Signal level (dBm)	Interferer level (dBm)	Spec. MER %	Test limit MER %	Minimum sample size
sensitivity	6	NBCH	TU50	-103 (-97)		8	8,96	6 500
sensitivity	5	MBCH	TU50	-103		8	8,96	6 500
co-channel interference	6	NBCH	TU50	-85	-104	7	7,840	9 000
co-channel interference	5	MBCH	TU50	-85	-104	6	6,720	9 000
adjacent channel interference	6	NBCH	TU50	-100 (-94)	-55 (-59)	7	7,840	9 000
inter-modulation	6	NBCH	STAT	-109	-47	2,5	3,050	6 500
blocking	6	NBCH	STAT	-109	-25	2,5	3,050	6 500
spurious response	6	NBCH	STAT	-109	-45	2,5	3,050	6 500

Table A.6: Test conditions for MS receiver PDO, class E

Test type	Channel type	Logical channel	Propagation condition	Signal level (dBm)	Interferer level (dBm)	Spec. MER %	Test limit MER %	Minimum sample size
sensitivity	6	NBCH	EQ200	-103		22	24,64	2 000
sensitivity	5	MBCH	EQ200	-103		21	23,52	2 000
sensitivity	6	NBCH	TU50	-103 (-97)		8	8,96	6 500
sensitivity	5	MBCH	TU50	-103		8	8,96	6 500
co-channel interference	6	NBCH	TU50	-85	-104	7	7,840	2 500
co-channel interference	5	MBCH	TU50	-85	-104	6	6,720	2 500
adjacent-channel interference	6	NBCH	TU50	-100 (-94)	-55 (-59)	7	7,840	9 000
inter-modulation	6	NBCH	STAT	-109	-47	2,5	3,050	6 500
blocking	6	NBCH	STAT	-109	-25	2,5	3,050	6 500
spurious response	6	NBCH	STAT	-109	-45	2,5	3,050	6 500

Table A.7: Test conditions for BS receiver V+D, class A

Test type	Channel type	Logical channel	Propagation condition	Signal level (dBm)	Interferer level (dBm)	Spec. BER or MER %	Test limit BER or MER %	Minimum sample size
nominal error	7	TCH/7,2	TU50	-85		<u>0,4</u>	<u>0,448</u>	3,6E6
nominal error	7	TCH/7,2	STAT	-20		<u>0,1</u>	<u>0,122</u>	170 000
sensitivity	8	SCH/F	TU50	-106 (-100)		11	12,32	6 600
sensitivity	9	STCH	TU50	-106		9	10,08	6 600
sensitivity	10	TCH/2,4 N = 1	HT200	-106		<u>1,3</u>	<u>1,456</u>	45 000
sensitivity	11	SCH/HU	HT200	-106		9,5	10,64	5 000
co-channel interference	8	SCH/F	HT200	-85	-104	9,2	10,304	7 000
adjacent channel interference	8	SCH/F	TU50	-103 (-97)	-58 (-62)	6	6,72	9 000
inter-modulation	7	TCH/7,2	STAT	-112	-47	<u>3,0</u>	<u>3,66</u>	5 800
blocking	7	TCH/7,2	STAT	-112	-25	<u>3,0</u>	<u>3,66</u>	5 800
spurious response	7	TCH/7,2	STAT	-112	-45	<u>3,0</u>	<u>3,66</u>	5 800

Table A.8: Test conditions for BS receiver V+D, class B

Test type	Channel type	Logical channel	Propagation condition	Signal level (dBm)	Interferer level (dBm)	Spec. BER or MER %	Test limit BER or MER %	Minimum sample size
nominal error	7	TCH/7,2	TU50	-85		0,4	0,448	3.6E6
nominal error	7	TCH/7,2	STAT	-20		0,1	0,122	170 000
sensitivity	8	SCH/F	TU50	-106 (-100)		8	8,96	6 600
sensitivity	9	STCH	TU50	-106		8	8,96	6 600
sensitivity	10	TCH/2,4 N = 1	TU50	-106		0,35	0,392	160 000
sensitivity	11	SCH/HU	TU50	-106		8	8,96	6 600
co-channel interference	8	SCH/F	TU50	-85	-104	6	6,72	7 000
adjacent channel interference	8	SCH/F	TU50	-103 (-97)	-58 (-62)	6	6,72	9 000
inter-modulation	7	TCH/7,2	STAT	-112	-47	4,0	4,88	4 000
blocking	7	TCH/7,2	STAT	-112	-25	4,0	4,88	4 000
spurious response	7	TCH/7,2	STAT	-112	-45	4,0	4,88	4 000

Table A.9: Test conditions for BS receiver PDO, class A

Test type	Channel type	Logical channel	Propagation condition	Signal level (dBm)	Interferer level (dBm)	Spec. MER %	Test limit MER %	Minimum sample size
sensitivity	12	NBCH	HT200	-106		11	12,32	4 500
sensitivity	12	NBCH	TU50	-106		9	10,08	6 600
co-channel interference	12	NBCH	TU50	-85	-104	7	7,84	9 000
adjacent channel interference	12	NBCH	TU50	-103 (-97)	-58 (-62)	7	7,84	9 000
inter-modulation	12	NBCH	STAT	-112	-47	9	10,08	6 600
blocking	12	NBCH	STAT	-112	-25	9	10,08	6 600
spurious response	12	NBCH	STAT	-112	-45	9	10,08	6 600

Table A.10: Test conditions for BS receiver PDO, class B

Test type	Channel type	Logical channel	Propagation condition	Signal level (dBm)	Interferer level (dBm)	Spec. MER %	Test limit MER %	Minimum sample size
sensitivity	12	NBCH	TU50	-106 (-100)		8	8,96	6 600
co-channel interference	12	NBCH	TU50	-85	-104	7	7,84	9 000
adjacent channel interference	12	NBCH	TU50	-103 (-97)	-58 (-62)	7	7,84	9 000
inter-modulation	12	NBCH	STAT	-112	-47	5	5,6	10 000
blocking	12	NBCH	STAT	-112	-25	5	5,6	10 000
spurious response	12	NBCH	STAT	-112	-45	5	5,6	10 000

Table A.11: PUEM Test table

Equipment type	Channel type	Logical channel	Propagation condition	Signal level (dBm)	Spec. PUEM	Bad unit (PUEM)	Test limit (Max No. Errors)	Sample size
MS(V+D)	2	SCH/F AACH	TU50	-103	10^{-5} 10^{-4}	$3,5 \times 10^{-4}$ $6,5 \times 10^{-4}$	2 8	31 200
MS(PDO)	6	NBCH	TU50	-103	10^{-5}	$3,5 \times 10^{-4}$	2	31 200
BS(V+D)	8	SCH/F	TU50	-106	10^{-5}	$3,5 \times 10^{-4}$	2	31 200
BS(PDO)	12	NBCH	TU50	-106	10^{-5}	$3,5 \times 10^{-4}$	2	31 200

A.3 Test signal T1, content of BSCH and BNCH/T (V+D) & MBCH/T (PDO)

The following tables define the information content of the BSCH and BNCH/T for V+D and MBCH/T for PDO bursts, used during testing.

Table A.12: Test signal T1 content of the BSCH (V+D) & MBCH/T (PDO)

Information element	Size (bits)	Values	Meaning
System code	4	0xxx 1xxx	V+D reserved PDO reserved
Base Colour Code	6	xxxxxx	any BCC value 1 to 63
Timeslot number	2	00	Timeslot 1
Frame number	5	10 010	Frame 18
Multiframe number	6	111 100	Multiframe 60
Sharing mode	2	00	Continuous transmission
TS reserved frames	3	xxx	do not care
U-plane DTX	1	x	do not care
Frame 18 extension	1	x	do not care
Reserved	1	x	do not care
Mobile Country Code	10	xxxxxxxxxx	any MCC value 0 to 1 023
Mobile Network Code	14	xxxxxxx xxxxxxx	any MNC value 0 to 16 383
Neighbour Cell Broadcast	2	00	do not care
Cell Service Level	2	00	do not care
Late Entry	1	0	do not care

Table A.13: Test signal T1 content of the BNCH/T(V+D) & MBCH/T (PDO)

Information element	Size (bits)	Values	Meaning
PDU type	2	10	Broadcast PDU
Broadcast type	2	00	SYSINFO PDU
Main carrier	12		test signal carrier number (defined in EN 300 392-2 [1], clause 21)
Frequency band	4		test signal carrier band (defined in EN 300 392-2 [1], clause 21)
Offset	2	xx	frequency offset (defined in EN 300 392-2 [1], clause 21)
Duplex spacing	3		defined in EN 300 392-2 [1], clause 21
Reverse operation	1	0 1	normal (defined in EN 300 392-2 [1], clause 21) reverse
No of common secondary control channels in use	2	00	none
MS_TXPWR_MAX_CELL	3	000 001 010 011 100 101 110 111	reserved 15 dBm 20 dBm 25 dBm 30 dBm 35 dBm 40 dBm 45 dBm
RXLEV_ACCESS_MIN	4	0000	Defined in EN 300 392-2 [1], clause 21
ACCESS_PARAMETER	4	0000 - 1111	- 53 dBm to - 23 dBm in 2 dB steps for subsequent power adjustments
RADIO_DOWNLINK_TIMEOUT	4	0000	Disable Radio Downlink Counter (RDC)
Tx_on	1	0 1	Reception on Transmission on
Tx_burst_type	1	0 1	Normal uplink burst Control uplink burst
T1_burst_type	5	00000 00001 00010 00011 00100 00101 00110 00111 01000 01001 01010 01011 01100 01101 01110 01111 10000 10001 10010 10011 10100 10101-11111	type 0: TCH/7,2 (downlink) type 1: TCH/7,2 (downlink) type 2: SCH/F (downlink) type 3: BSCH +SCH/HD (downlink) type 4: TCH/2,4 N = 1 (downlink) type 5: MBCH (PDO downlink) type 6: NBCH (PDO downlink) type 7: TCH/7,2 (uplink) type 8: SCH/F (uplink) type 9: STCH + STCH (uplink) type 10: TCH/2,4 N = 1 (uplink) type 11: SCH/HU + SCH/HU (uplink) type 12: NBCH (PDO uplink) type 13: random synchronization bursts type 14: random synchronization sub-bursts type 15: TCH/S PRBS tests (downlink) type 16: TCH/S PRBS tests (uplink) type 17: TCH/4,8 N = 1 (downlink) type 18: TCH/4,8 N = 1 (uplink) type 19: TCH/S speech codec test (downlink) type 20: TCH/S speech codec test (uplink) reserved
Loop_back	1	0 1	Loopback off Loopback on
reserved	73		do not care

Annex B (normative): Radio test system functions

B.1 Test transmitter and receiver

B.1.1 General

The task of the test transmitter/receiver is to simulate either TETRA base station or mobile station functions required while performing the Radio Conformance Testing procedures on the TETRA equipment according to the clauses 8, 9 and 10. These tasks include:

- supporting all the logical channels defined in TETRA;
- supporting the full range of transmit and receive frequencies of TETRA according to EN 300 392-2 [1], clause 6;
- supplying appropriate signals, see subclause B.1.5;
- delaying the transmitted bursts in steps of less than or equal to $\frac{1}{4}$ symbol duration, whenever required;
- measuring the nominal Tx power from the DUT in the range from +8 dBm to +48 dBm;
- activating and de-activating specific test modes in the MS, whenever required (optional feature).

B.1.2 Sampling system

B.1.2.1 General

The task of the sampling system, a subsystem of the test receiver, is to acquire a sampled version of a wanted TETRA modulated radio signal or an unwanted emission through the TETRA filter. The acquired complex samples (I-Q base band representation) are used for modulation accuracy and power measurements.

A sampling rate of at least 4 samples per symbol duration is sufficient. The receive frequency of the sampling system shall be adjustable to the nominal equipment transmit frequencies with an uncertainty of $\pm 0,02$ ppm ($\pm 0,01$ ppm for frequencies above 520 MHz). Prior to sampling, frequency down conversion from RF to IF and appropriate IF filtering may take place.

The sampling system shall meet the requirements defined in the subclauses B.1.2.2 to B.1.2.4.

B.1.2.2 TETRA filter

The TETRA filter is the receive filter of the sampling system, defined in EN 300 392-2 [1], clause 5, and additionally the requirements defined in subclauses B.1.2.3 to B.1.2.5 shall be met for the sampling system. The TETRA filter shall have a minimum length of 30 symbols.

B.1.2.3 Adjacent channel power measurements

The residual adjacent channel level of the test system, as measured in subclause 8.3, shall not exceed the limits shown in table B.1, at the listed frequency offsets from the nominal carrier frequencies.

Table B.1: Maximum residual adjacent channel level of the test system

Frequency offset	Maximum level
25 kHz	-70 dBc
50 kHz	-80 dBc
75 kHz	-80 dBc

B.1.2.4 Modulation accuracy measurements

The residual modulation accuracy of the test system shall meet the following limits when measuring either a continuous or discontinuous signal. The residual RMS vector error shall be less than 0,01 and the peak vector error shall be less than 0,03.

B.1.2.5 Measurement of unwanted output power in the non-active transmit state

The residual non-active power level of the test system shall not exceed -80 dBc.

B.1.3 Spectrum analyser

Spectrum analysis equipment is to be used as a power detecting device (in frequency domain) and is characterized as follows:

- frequency range: 9 kHz to 4 GHz (9 kHz to 12,75 GHz for equipment capable of operating at frequencies greater than 470 MHz);
- power level range: -80 dBm to +20 dBm;
- dynamic range: 80 dB;
- resolution bandwidths: 30 kHz, 100 kHz, 300 kHz, 1 MHz, 3 MHz;
- video bandwidths: 30 kHz, 100 kHz, 300 kHz, 1 MHz, 3 MHz;
- peak hold function selectable.

This specification may be achieved using a combination of equipment, for instance frequency down-converters and attenuators.

B.1.4 Error rate tester

The task of the error rate tester is to measure test bit sequences which have been received by the receiver under test in the T1 test signal. A Pseudo Random Bit Sequence (PRBS) with a length of 511 bits shall be used according to ITU-T Recommendation O.153 [3]. The measurement task is to compare the bits decoded by the receiver under test with the original ones and calculate the appropriate error rates.

B.1.5 Test signal requirements

B.1.5.1 On channel test signal T1

Modulation:	TETRA Modulated (see test signal T1 in subclause 5.3). The RMS vector error and the peak vector error in any burst as defined in EN 300 392-2 [1], clause 6 shall be less than 0,03 and 0,1, respectively. These errors shall be measured in a TETRA filter defined in subclause B.1.2.2.
Frequency range:	TETRA MS and BS receive frequencies.
Uncertainty of frequency:	$\pm 0,02$ ppm ($\pm 0,01$ ppm for frequencies above 520 MHz).

Power level range: -115 dBm to -20 dBm, adjustable in steps of 0,2 dB or less.
 Uncertainty of power level: See clause 11.

B.1.5.2 Interfering test signal T2

Modulation: TETRA Modulated (see test signal T2 in subclause 5.3). The RMS vector error and the peak vector error in any burst as defined in EN 300 392-2 [1], clause 6 shall be less than 0,03 and 0,1, respectively. These errors shall be measured in a TETRA filter defined in subclause B.1.2.2.

Frequency range: TETRA MS and BS receive frequencies.

Uncertainty of frequency: $\pm 0,2$ ppm ($\pm 0,1$ ppm for frequencies above 520 MHz).

Power level range: -110 dBm to -50 dBm (after combiner), adjustable in steps of 1 dB or less.

Uncertainty of power level: See clause 11.

Adjacent channel power: The adjacent channel power of test signal T2 shall not exceed -70 dBc at 25 kHz offset from the nominal carrier frequency, measured in a TETRA filter defined in subclause B.1.2.2. This limit applies to the T2 Test signal under static propagation conditions only.

B.1.5.3 Interfering test signal T3

Modulation: T3 is an unmodulated RF signal (see test signal T3 in subclause 5.3).

Frequency range: 10 MHz to 4 GHz.

Uncertainty of frequency: $\pm 0,2$ ppm ($\pm 0,1$ ppm for frequencies above 520 MHz).

Power level range: -60 dBm to -25 dBm (after combiner), adjustable in steps of 1 dB or less. Power levels up to 16 dBm are required in the MS transmit band; for transmitter intermodulation attenuation measurement only.

Uncertainty of power level: See clause 11.

Noise: See clause 11.

B.1.6 Propagation simulators

The task of the propagation simulators is to take into account the effect of the propagation conditions, as described in EN 300 392-2 [1], clause 6, while testing the receiver performance. The propagation simulators may be either internal or external to the T1 and T2 signal generators. The characteristics of the propagation simulator shall be as follows:

- uncertainty of relative path delay of the fading profile: ± 100 ns;
- uncertainty of relative amplitude level of the fading profile: $\pm 0,5$ dB;
- the fading profile of all the fading paths shall be uncorrelated.

B.1.7 Timing measurement unit

The timing measurement unit is a time interval counter within the test system. It compares the timing (training sequence) of bursts received by the test receiver with the internal timing reference of the test system. The bursts (training sequences) transmitted by the test transmitter shall be synchronized to this internal timing reference.

B.1.8 Passive test system components

The task of the passive components is to establish the appropriate interconnection of the test system and the equipment under test. The required composition and characteristics of the passive components depend on the overall implementation of the test system and are not to be defined in this specification. However, the following components may be useful herein: RF combiner, power splitter, isolating device, RF attenuators, connecting cables, mixers, filters and switches.

B.1.9 Test system controller

The test system controller co-ordinates the test system functions via an appropriate interface. It may also perform the calculations required by the test procedures and present the final test results whenever appropriate.

Annex C (normative): TETRA Test Connector Interface (TTCI)

Annex C defines a TETRA Test Connector Interface for use between TETRA MS/BS equipment and TETRA test equipment.

One of the facilities that has to be provided by the applicant, when submitting equipment for type testing, is a test connector, which provides decoded data output for all uplink logical channels in the case of base station (BS) and downlink logical channels in the case of mobile station (MS) to be tested.

The TETRA Test Connector Interface (TTCI) is a communication link between the test equipment and the mobile station and base station by which it is possible to automatically register the status, indications and performance of the mobile station.

For the purposes of annex C, the following abbreviations apply:

CRC	Cyclic Redundancy Check
E	Stop bit
ETX	End of data
Frame	Used on layer 2 to transfer messages to and from layer 3
Message	Information on layer 3
MI	Message Identifier
RSSI	Received Signal Strength Indicator
Rx	Receiver parameters
S	Start bit
ST	Status indicator
STX	Start of data
TTCI	TETRA Test Connector Interface
Tx	Transmitter parameters

C.1 General

Subclause 4.1.1 requires the Mobile Station (MS) and Base Station (BS) only to send decoded data to the test equipment. The TETRA Test Connector Interface (TTCI) is mainly defined as a one-way protocol from the MS/BS to the test equipment, with an option for bi-directional operation. Messages from the test equipment to the MS/BS can be ignored by the MS/BS.

The definition of the TTCI is divided into three different layers. On layer 1 the use of a 25-pole socket with standard electrical characteristics for serial communication is defined. On layer 2, an extremely simple frame oriented protocol is defined. On layer 3, messages for decoded data are defined. Each layer is defined independently of the surrounding layers.

C.2 Formal aspects

- a) The TTCI is optional for the MS/BS.
- b) The TTCI is mandatory for the test equipment.
- c) If the TTCI is to be used in conformance testing of an MS/BS, it shall be possible to connect the test equipment to the test connector on the MS/BS, or to an adapter connected to the same MS/BS. If an adapter is to be used, it shall be provided by the manufacturer.
- d) If the MS/BS fulfils the requirements performed with the use of a TTCI, the MS/BS is regarded as having passed the test.

- e) If the MS/BS is rejected in a test performed with TTCI, the test shall be repeated if possible on the same TETRA equipment with the device carrying the TTCI to the MS/BS removed. The MS/BS shall be regarded as fulfilling the requirements, if it then passes the test.
- f) When using the TTCI, the MS / BS does not necessarily conform to the RF requirements. Therefore, tests concerning Rx and Tx parameters on MS / BS with cabinet radiation tests for all types of MS / BS will never be performed with the use of the TTCI.

C.3 TTCI, layer 1

C.3.1 Mechanical and Electrical Characteristics

The TTCI interface shall use the standard 25-pin connector, with pin assignment as shown in table C.1:

Table C.1: Pin assignments for the TTCI

Pin	Function	Source
2	Transmitted data	Test equipment
3	Received data	MS/BS
7	TTCI signal ground	

The electrical characteristics of the interface shall be as described in clause C.7. If the MS/BS provider supports a different pin assignment or different electrical characteristics, it will be the provider's responsibility to provide an interface converter to the pin assignment and electrical characteristics described above.

C.3.2 Transmission and Reception Characteristics

The TTCI uses asynchronous serial data transmission with 1 start bit (S), 8 data bits (D1 to D8), no parity and 1 stop bit (E), shown in figure C.1.

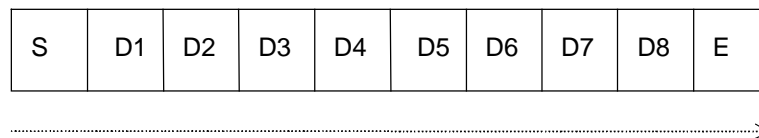

Figure C.1: Use of start and stop bits

The conditions on start and stop characters are defined in CCITT Recommendation V.1 [6]. The transmission rates are: 19 200, 28 800 bits per second.

NOTE: For RF conformance testing, the effective rate must be equal or greater than 19 200 (there are 68 octets (TCH+AACH) to be transferred to the test equipment between two consecutive timeslots).

C.4 TTCI, Layer 2

C.4.1 General Structure

On layer 2, frames are used to carry data from higher layers. Frames consist of one or several octets. One frame with variable length is used to carry data from higher layers.

C.4.2 Frame Structure

Two octets, called characters, indicate start and stop of I-frames (Information frames), shown in table C.2

Table C.2: Frame structure

Abbr.	Meaning	Dec. value	Bit pattern
STX	Start of data	02	0000 0010
ETX	End of data	03	0000 0011

Information from higher layers is transferred in I-frames with the structure shown in table C.3:

Table C.3: Information from higher layer in I-frames

Field name	No. of octets	Value	Start of octet no.
Start	1	Character STX	1
Length	1	Length of data (note 1)	2
Data	0-255	Content of data (note 2)	3
Check	1	Error detection (note 3)	Length+3
End	1	Character ETX	Length+4

NOTE 1: The total number of data octets in the data field of the frame is calculated. The value shall be in the range of (0...255 decimal). The corresponding binary value is put into the Length field.

NOTE 2: Data to the higher layers are in the form of octets (bytes).

NOTE 3: Longitudinal checksum is created by exclusive OR on all characters starting with the Start field and ending with the last octet before the Check field. The value, one octet, is mapped into the Check field.

C.4.3 Flow of I-frames on Layer 2

C.4.3.1 Transmission of Frames

A multiple frame starts with the first octet being the character STX and stops with the last octet with the content ETX, shown in figure C.2. The time between the start bits of two consecutive octets shall not be longer than T22.

**Figure C.2: The time between the start bits of two consecutive octets**

The time between two frames is measured from the start bit of the last octet on the n^{th} frame to the start bit of the first octet of the $n+1^{\text{st}}$ frame, shown in figure C.3. The time between two consecutive frames shall not be less than T23.

**Figure C.3: The time between two consecutive frames**

C.4.3.2 Reception of frames

Start of frame is defined as (more than $2 \times$ time T22 since reception of previous octet) AND (reception of STX). End of frame is defined as (Reception of ETX in octet number (length+3)) OR (more than $2 \times$ time T22 since reception of previous octet).

C.4.3.3 Parameters on Layer 2

Layer 2 parameters T22 and T23 are defined in table C.4:

Table C.4: Timer values on layer 2

Bit rate	Value of T22	Value of T23
19 200	0,8 ms	1,8 ms
28 800	0,53 ms	1,2 ms

C.5 TTCI, Layer 3

C.5.1 Message structure

Messages are used on layer 3. They are defined by Message Identifier (MI) in the range of (0...255). The MI is always the first octet of the message. Table C.5 defines the usage of the TTCI Message Identifiers.

Table C.5: Use of message identifiers

MI value	Use
0 - 49	Not used in TETRA.
50 - 119	Not used in TETRA.
120 - 179	TETRA General messages. All undefined messages are reserved for TETRA future use.
180 - 209	Not used in TETRA.
210 - 239	Not used in TETRA.
240 - 255	Reserved for Layer 3 error handling. All undefined values reserved for future use.

Table C.6 lists the MI values used in TETRA to send messages from the MS/BS to the test equipment:

Table C.6: Block types

MI value	Abbr.	Meaning
120	DATO	Data output from the MS/BS to the test equipment. Contains the information received in the logical channel under testing. Preceded by one byte of status to indicate Message Error Flag and the channel type.
121	CONTROL	Control commands from the test equipment to BS contains control information about power levels and carrier frequency of BS
122	CODEC	Codec conformance testing
123	MS sync	Optional indicator for successful decoding of transmitted synchronization bursts
240	ST indicator	Status Detected, in MS or BS.

C.5.2 Definitions of the Messages

C.5.2.1 DATO

This message shown in table C.7 is used by the MS and the BS to send the bits extracted from the logical channel under test to the test equipment. In addition, the first octet of the message will contain the Message Error Flag octet. The test equipment shall record those instances when an message error occurred, but the Message Error Flag was not set. This can be used by the test equipment to calculate the MER and PUEM. If the last octet is not full, the rest of the octet is regarded as don't care.

The AACH decoded information will be available on the test connector following the logical channel(s) information regardless of the channel type tested. In frame 18 the AACH decoded information will also be available following the BSCH and BNCH/T information.

The equipment under test shall provide on the test connector, together with the decoded information, an indication of the CRC pass/fail result. The indication will be provided for each of the logical channels and the AACH. That information will be used by the test equipment for MER or PUEM measurements.

Table C.7: Format of DATO message

Octet Number	Meaning
1	Message Identifier
2	Message Error Flag
3	Recovered bits 1 - 8
4	Recovered bits 9 - 16
.	.
.	.
.	.
56	Recovered bits 425 - 432

The Message Error Flag octet is composed of two fields as shown in figure C.4:

bits 8 - 5	bits 4-1
Result	Channel

Figure C.4: Format of Message Error Flag octet

Where **Result** specifies error found by the MS/BS as shown in table C.8 (values are in Binary):

Table C.8: Message Error Flag Result Values

Result value	Meaning
0000	No Error
0001	Lost slot
0010	Bad CRC
0011	No RSSI
0100	Out of timing
0101	General Error

and the **Channel** is as shown in table C.9 (values are in Binary):

Table C.9: Message Error Flag Channel Values

Channel value	Meaning
0000	TCH/7,2
0001	TCH/4,8
0010	TCH/2,4
0011	TCH/S
0100	AACH
0101	BSCH
0110	BNCH
0111	SCH/F
1000	SCH/HD
1001	SCH/HU
1010	STCH
1011	NBCH
1100	MBCH

C.5.2.1.1 Test equipment error handling

The test equipment will handle DATO messages with result 1, result 3, result 4, result 5 as a slot in which all the decoded information was erroneous and the device under test detected it as a bad slot.

The test equipment will handle DATO messages with result 2 as a slot with partial data erroneous. It shall use the information received for the BER measurement and shall use that indication for the MER/PUEM calculation.

C.5.2.2 Bi-directional operation of the TTCl

This message is optional to implement in the BS. The message is used for the test equipment to send control information to the BS.

The BS is controlled by the BNCH/T and the BS power octet as shown in table C.10. The BNCH/T is defined in table A.13. If an octet is not full, the rest of the octet is regarded as don't care.

Table C.10: Format of BS Control message

Octet Number	Meaning
1	Message Identifier
2	BS power
3	BNCH/T bits 1 - 8 (PDU type - ...)
4	BNCH/T bits 9 - 16
.	.
.	.
.	.
18	BNCH/T bits 121 - 128 (... - reserved)

The BS power octet is composed of two fields, shown in figure C.5:



Figure C.5: format of BS power octet

where **power** specifies that the field is used to set up power:

- 0000 = power;

and the **level** is as shown in table C.11 (values are in Binary):

Table C.11: power level values

level value	BS Tx power level
0000	46 dBm
0001	44 dBm
0010	42 dBm
0011	40 dBm
0100	38 dBm
0101	36 dBm
0110	34 dBm
0111	32 dBm
1000	30 dBm
1001	28 dBm

The BNCH/T message as used to control the MS can be used to control the BS. For control of a BS the MS_TXPWR_MAX_CELL, RXLEV_ACCESS_MIN and ACCESS_PARAMETER are ignored.

C.5.2.3 Codec conformance testing

This message is used by the MS and BS to send the bits extracted from the Codec under test to the TETRA system simulator. In addition, the first octet of the message, will contain the Message Error Flag octet. The test equipment shall record those instances when an message error occurred. It is optional to use the TTCI for conformance Codec testing.

For octet numbering and the meaning of the octets see subclause C.5.2.1, DATO. The message error flag is defined in subclause C.5.2.1, DATO. For test equipment error handling see subclause C.5.2.1.1, Test equipment error handling.

C.5.2.4 ST indicator

Used by the MS/BS to indicate an internal status as shown in table C.12. The test equipment shall discard this message.

Table C.12: Format of Status message

Octet Number	Meaning
1	Message Identifier
2	Status Indicator to be defined by the MS/BS manufacturer

C.6 Control of MS/BS

One of the following options is mandatory for the MS/BS, but all options are mandatory for the test equipment.

- Manual intervention of BS/MS.
- Bi-directional operation of the test interface.
- The MS is controlled by T1.

C.6.1 Manual intervention of MS/BS

It is up to the manufacturer to provide a manual intervention to control the carrier frequency and the power levels of the MS/BS under test. If this option is used the CONTROL message may not be used.

C.6.2 Bi-directional operation of the test interface

Using the TTCI in bi-directional mode is optional. In this mode the test connector interface will work in a bi-directional mode, and the BS shall be capable of receiving the CONTROL messages on the test connector interface. Layer 1 is defined in clause C.3, and layer 2 is defined in clause C.4.

C.6.3 MS controlled by T1

In this mode the MS power settings and frequency settings are controlled by the T1 signal on the air-interface.

C.7 Characteristics of the interface

It shall be possible to connect the test equipment to the MS/BS or to an adapter connected to the MS/BS. If an adapter is to be used, it shall be provided by the manufacturer of the MS/BS.

C.7.1 Mechanical characteristics of the interface

The interface shall use a 25-pin connector, detailed in ISO 2110 [7]; the MS/BS shall use the female part.

The manufacturer may provide this interface on an external test "adapter"; the pin connection shall be as described in table C.1.

C.7.2 Electric characteristics of the interface

The state of a signal pin is defined by the voltage (v) between the pin and its associated ground as shown in table C.13:

Table C.13: Electric characteristics of the test interface

Logical state	Voltage (v)
0 or "LOW"	$+5\text{ V} < v < +15\text{ V}$
1 or "HIGH"	$-5\text{ V} > v > -15\text{ V}$
undefined	$-5\text{ V} < v < +5\text{ V}$
forbidden	$v < -15\text{ V}, v > +15\text{ V}$

C.8 Codec conformance testing using the TTCI

This clause specifies a test methodology for using the TTCI for speech codec testing. It is optional to use the TTCI to perform speech codec testing.

C.8.1 Codec conformance test methodology using the TTCI

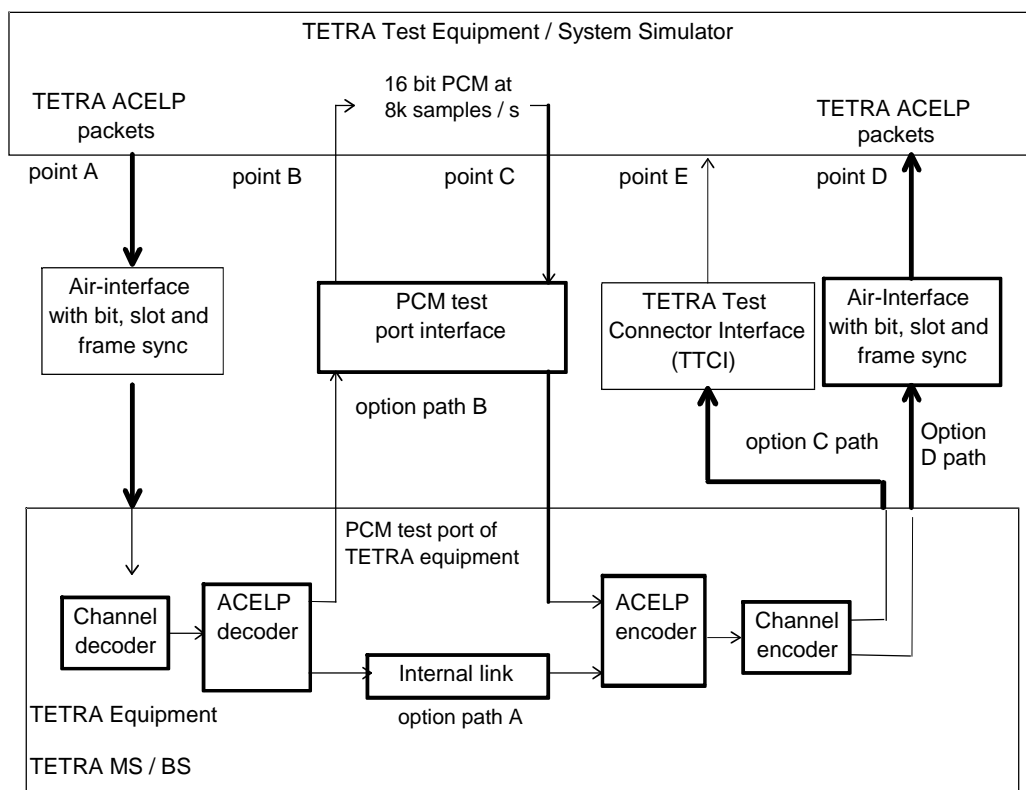

Figure C.6: TTCI and Air Interface Test points for conformance testing the MS / BS speech codec

Figure C.6 shows the various stages and blocks involved in testing the speech codec using the TTCI. As can be seen, the test sequence can be recovered from the TETRA equipment by various methods; one method is to use the air interface method, another method is to use the TTCI.

It shall be the responsibility of the TETRA equipment manufacturer together with the test laboratory to select the most appropriate option for recovering the test sequence.

The PCM test port as referred to in figure C.6, is not specified in the present document. However an informative implementation of this port is given in ETS 300 607-1 [19], subclause 36.4 (Digital Audio Interface (DAI)).

TTCI

The injected test signal from point A can be recovered at point E using the TTCI. It is optional for the TETRA equipment manufacturers to use option path A or option path B. It is the responsibility for the TETRA equipment manufacturer together with the test laboratory to select the most appropriate option.

Air interface method

A description of the air interface method is given in ETS 300 395-4 [8] and in annex D.

Annex D (normative): RF Test Facility using RF Loop Back

Annex D defines a common means of testing RF parameters using an **RF loop back** facility. It includes definitions of two separate loopback test methods, **TETRA Test mode** (defined in clauses D.1 to D.6) and **T1 test mode** (defined in clauses D.7 and D.8).

Clauses D.1 to D.6 define a mandatory **TETRA Test (TT) protocol** entity for use on the air interface between a TETRA MS and a **TETRA System Simulator (TSS)** to enable the **RF loop back** to be activated. This method is intended for performing tests on production models of TETRA MS equipment. It assumes the use of a **TSS** such as a Radio Test Set or similar test equipment which is capable of exchanging air interface signalling messages with the MS under test.

An **RF loop back** facility enables manufacturing, servicing or conformance testing to be performed without the need for test connectors or leads (except of course for antenna connections) and does not need access to authentication and encryption algorithms. The MS is tested in a state which is similar to its normal operating mode, using standard non-proprietary signalling procedures to set up voice and data calls on traffic channels.

Clauses D.7 and D.8 define a simple **T1 test mode RF Loop Back** method for MS and BS equipment which does not involve any signalling protocol to provide a 'virtual test connector' for performing the receiver tests specified in clause 9. This simple method is intended for the purpose of performing radio conformance testing using the T1 Test Signal, and it allows radio conformance tests to be performed in isolation on MS and BS equipment which may not implement the higher layers of TETRA protocol. The **T1 test mode RF loopback** method is optional.

The simple **T1 loopback test mode** does not require the **test system** to support any channel decoding or signalling, and could be implemented in the same test equipment as is used for transmission and modulation measurements. The return channel for T1 loopback is a TCH/7,2, so it is only necessary for the test equipment to receive and demodulate the burst (already required for modulation measurements) and de-scramble the burst data (which is simply a bit-wise exclusive-OR operation with a known pattern).

At present the applicability of this annex is to TETRA V+D equipment. It is also applicable to conformance testing of Direct Mode (DMO) equipment tested in accordance with annex F.

For the purposes of this annex the following definitions apply:

- **normal operational mode:** the state a TETRA MS is in for its normal intended operation in a TETRA system when no test modes have been selected;
- **TETRA Test mode:** the state a TETRA MS is in when it has been set for TETRA Test mode and is registered to a **TETRA System Simulator (TSS)** generating a **test broadcast channel**. In this state the MS shall react to standard message sequences, as it would in **normal operational mode**, with the exceptions outlined in subclause D.3.2.1, and also **TETRA Test (TT) protocol** messages;
- **TETRA loop back mode:** the sub-mode of **TETRA Test mode** when a test call has been set up and **RF loopback** is active;
- **test broadcast channel:** the Main Control Channel (MCCH) generated by a **TETRA System Simulator** using a Mobile Country Code (MCC) of 001 and a Mobile Network Code (MNC) of 1;
- **test call:** is any call sequence made when in **TETRA Test mode**. The call procedures possible shall be limited by the capability of the TETRA MS;
- **duplex test call:** a **test call** resulting in reception and transmission of a traffic channel in the same TDMA frame on a single timeslot;
- **T1 test mode:** the special test mode which MS and BS equipment is required to implement when submitted for conformance testing, defined in subclause 5.2, using the T1 test signal defined in subclause 5.3.2 and either a physical test connector defined in annex C or a virtual test connector (**RF loopback**) defined in this annex. For the purposes of this annex, **T1 test mode** includes the simple **T1 loopback test mode** defined in clauses D.7 and D.8 as a virtual test connector;
- **normal T1 test mode:** the sub-mode of **T1 test mode** when **RF loopback** is not active;

- **T1 loopback test mode:** the sub-mode of **T1 test mode** when **RF loopback** is active;
- **RF loopback:** reception at the air interface of a logical channel which is channel decoded as far as the TMV-SAP (defined in EN 300 392-2 [1] clause 19) where the output of the channel decoder is transferred to the input of a channel encoder for re-transmission at the air interface. This permits test equipment to measure receiver performance using only the antenna connector and standard non-proprietary signalling. The loopback may alternatively take place at the digital audio interface of a speech codec for the purpose of bit-exact codec conformance testing;
- **TETRA Test protocol:** the set of air interface messages between the **TSS** and the MS which are used to control the operation of **TETRA Test mode** and to select and de-select the **TETRA loop back mode**. These messages are identified by a unique protocol discriminator in the MLE header;
- **TETRA System Simulator:** test equipment which is capable of generating a TETRA MCCH and a TETRA Traffic Channel (TCH) in order to simulate a TETRA BS, receiving and decoding control and traffic transmissions from a TETRA MS, and implementing sufficient TETRA protocol such that a TETRA MS under test in **TETRA Test mode** is able to perform the operations defined in annex D;
- **test system:** test equipment which is used for radio conformance testing, including a T1 signal generator, but which does not need to exchange TETRA protocol messages with the MS or BS under test, other than the generation of BSCH/T and BNCH/T information. For the purposes of supporting **T1 loopback test mode**, the test system shall be capable of receiving, demodulating and de-scrambling TCH/7,2 data in bursts transmitted by the MS or BS under test, but no other channel decoding capability is required.

For the purposes of this annex the following general abbreviations apply:

TT	TETRA Test protocol
TSS	TETRA System Simulator
LTT-SAP	Service Access Point for TT entity to access Mobile Link Entity (MLE)
T-TEST	Layer 3 timer (30s) for confirmation of setting of TETRA Test mode

D.1 Introduction to the TETRA Test (TT) protocol for RF loop back test

This clause is an introduction to the requirements for the mandatory **TETRA Test (TT) protocol** for operation over the TETRA Air Interface (AI). **This clause does not apply to the T1 test mode.**

D.1.1 Outline requirements

The **TETRA Test protocol** shall provide the means to activate the RF loop back test facility of TETRA MS equipment, thus using the AI and avoiding the use of special test connectors and their associated protocols. It shall enable the following mandatory test functions to be performed:

- enable the use of test mode in the TETRA MS by means of a known manual selection sequence, and by recognition of a **TETRA System Simulator (TSS)** generating a valid **test broadcast channel**;
- confirm that the TETRA MS is in **TETRA Test mode** by means of an air interface message;
- remove the **TETRA Test mode** by an air interface message or automatically at power down;
- perform **test call** set-up and clear-downs without the need for the test equipment to have knowledge of the security keys and algorithms (for encryption and authentication);
- set-up a **duplex test call** using a single timeslot when in test mode, whether or not this is possible in **normal operational mode**;
- obtain the equipment identity, power class, and receiver class from the MS;
- enable **TETRA loop back mode** to be selected and de-selected for single-slot duplex traffic channels;
- enable received traffic channels to be decoded as far as the TMV-SAP and then re-encoded and retransmitted over the air interface (**RF loop back**).

D.1.2 Test Modes

TETRA test mode shall be activated as described in subclause D.3.1; in this mode the TETRA MS behaves as if it were operating in a normal TETRA environment and shall be capable of registering and placing or receiving calls to or from a **TETRA System Simulator (TSS)** as well as obeying commands from the **TSS** to change frequency channel, timeslot and MS power level. The MS shall attempt to register with the **TSS** when the **TSS** is simulating a Base Station (BS). The TETRA MS shall be able to transmit and receive all logical channels for which it has been configured. However in this mode the MS shall not use the air interface encryption, the MS shall not attempt to challenge the **TSS** for authentication, and the **TSS** shall not attempt to challenge the MS for authentication. Certain MM messages (defined in section D.3.2.1) shall be ignored by the MS. When requested by the **TSS**, the TETRA MS shall identify itself with its TETRA Equipment Identity (TEI), power class (1, 1L, 2, 2L, 3, 3L, 4, 4L, 5 or 5L), and MS receiver class (A, B or E). The MS shall also supply its current TETRA Subscriber Identity (TSI) if available and applicable.

TETRA loop back mode is a sub-mode of **TETRA Test mode** and is only accessible when **TETRA Test mode** is active and a single-slot **duplex test call** is in progress. A TETRA MS capable of only simplex operation in its **normal operational mode** shall be capable of a **duplex test call** in **TETRA Test mode**, although this need not include speech codec or data terminal operations. The TETRA MS shall receive the current downlink traffic channel and after decoding as far as the TMV-SAP, re-encode and return the contents on the current uplink traffic channel, being the same type of channel as that received on the downlink. In the case of TCH/S, loop back with Bad Frame Indication (BFI) may be selected, whereby a recognizable bit pattern is returned in the event that a received and decoded speech frame indicates parity failure.

D.1.3 Switching for loop back test mode

Figure D.1 shows the functional requirements for loop back test modes. The actual physical implementation is left open to the manufacturer.

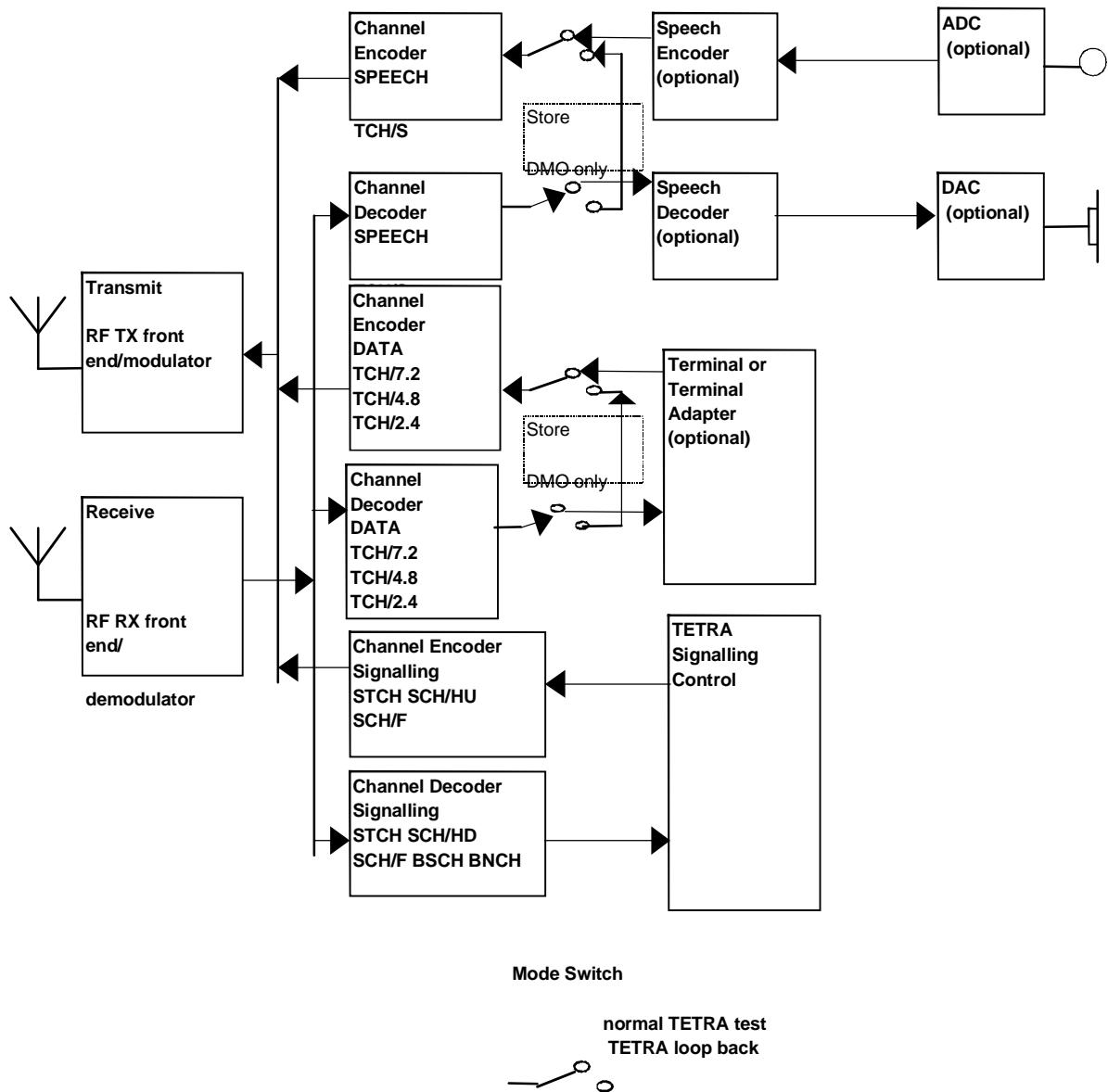
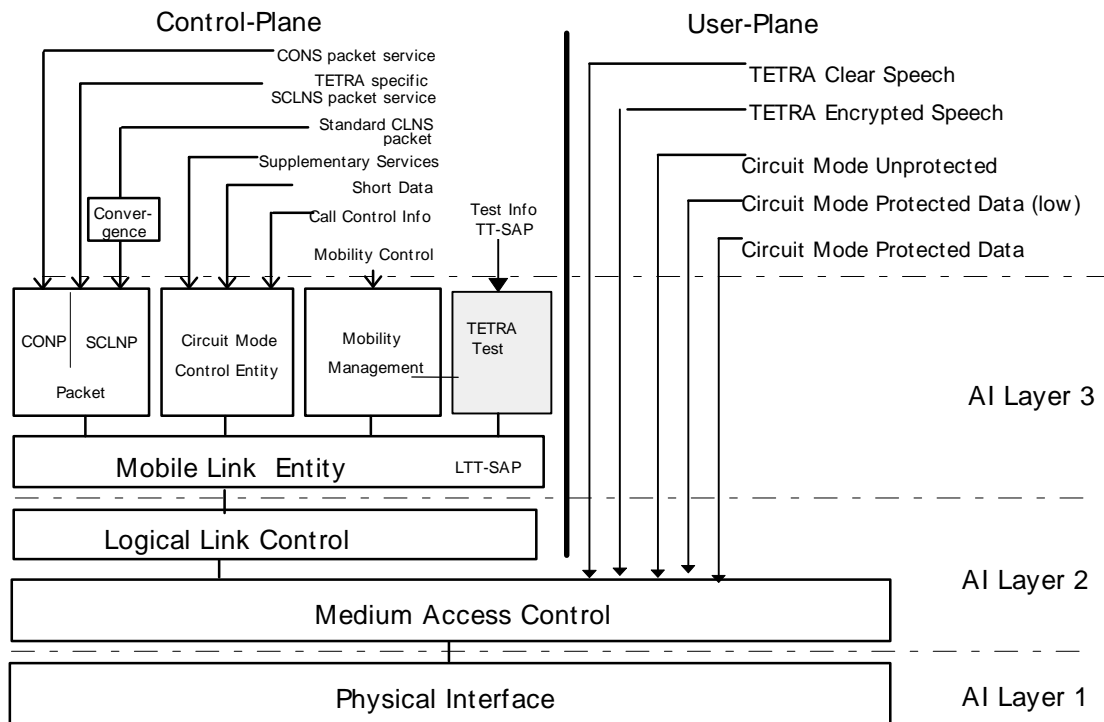

Figure D.1: Functional requirements for TETRA loop back

D.2 TETRA Test Entity

This clause defines the Services offered by the **TETRA Test** entity for the TETRA layer 3 Air Interface. **This clause does not apply to the T1 test mode.**

The **TETRA Test** entity shall provide access to special test procedures (defined in annex D) through a TETRA Test Service Access Point (TT-SAP), and uses the services of the Mobile Link Entity (MLE) through the **LTT-SAP**. Figure D.2 below shows an overview of how the TETRA Test entity fits within the general TETRA protocol stack. During **TETRA Test mode**, interaction between the TT entity and the Mobility Management (MM) entity may be required in order to restrict the MM operation as defined in subclause D.3.2.1.



	Service Access Point (SAP);
AI	Air Interface
C-plane	Control-plane
CLNS	ISO Connectionless Network Service;
CMCE	Circuit Mode Control Entity;
CONP	Connection Oriented Network Protocol;
SCLNP	Specific Connectionless Network Protocol;
U-plane	User-plane

Figure D.2: Mobile station protocol stack with TETRA Test (TT) entity

D.3 TETRA RF loop back test protocol

This clause defines the **TETRA Test (TT) protocol**. **This clause does not apply to the T1 test mode**. A more detailed informative description of operation is given in annex E.

D.3.1 Setting the TETRA MS into TETRA Test mode

Prior to operation in **TETRA Test mode**, it is necessary to perform some procedure to enable the use of **TETRA Test mode**.

Setting a TETRA MS into **TETRA Test mode** shall be by a manual selection and may additionally be possible by a programming interface. The manual selection will depend on the user controls (if any) of the MS, and could be for example a keypad sequence, a link on an interface connector, or use of a special test SIM, as appropriate. This shall be followed by recognition of a **test broadcast channel** from a **TSS** with a MCC of 001 and a MNC of 1. The **TSS** shall require the MS to register to the **TSS**.

To enable efficient in-service testing and repair in a multiple supplier situation it is recommended that the procedure for manual activation of **TETRA Test mode** is one of a limited number of common methods. The procedure for enabling **TETRA Test mode** shall be stated at conformance testing as part of the PICS for each TETRA MS. Where possible, the MS shall indicate to the user that it is in **TETRA Test mode**.

In **TETRA test mode** the TETRA MS shall allow **test calls** to be set up from the **TSS** or the TETRA MS and shall allow routine functions to be performed such as registration procedure and exercising some supplementary services if supported. Additionally, it shall be possible for the test system to obtain from a MS under test its equipment identity (TEI), power class, and receiver class.

With a **test call** in progress, **TETRA loop back** mode can be selected which shall configure the TETRA MS to loop back the current traffic channel to the **TSS** without access to special test connectors. This enables the **TSS** to measure receiver performance of the MS in terms of Bit Error Rate (BER) and, in the case of TCH/S, Probability of Undetected Erroneous Message (PUEM) and Message Erasure Rate (MER). The TETRA MS shall return received traffic channel data via its air interface thus also allowing RF power, burst profile, frequency and modulation accuracy measurements to be performed on the transmitter of the MS with the content of the scrambled bits of the transmitted bursts being supplied by the **TSS**.

D.3.2 TETRA TEST protocol

To operate the **TETRA Test mode** over the air interface the **TETRA Test (TT) Protocol** shall be used with the protocol discriminator reserved for test purposes in the Mobile Link Entity (MLE) protocol, defined in EN 300 392-2 [1] subclause 18.5.21. The **TETRA Test protocol** shall use services provided by the MLE at a **LTT-SAP**. When **TETRA Test mode** is not enabled, the TETRA MS shall ignore all messages with the TETRA Test (TT) protocol discriminator.

The **TETRA Test (TT) protocol** messages are used to perform the following operations.

D.3.2.1 Confirming that TETRA TEST MODE is set

When the TETRA MS is set into **TETRA Test mode** it shall start a timer **T-TEST**. This timer is stopped when the TETRA MS is registered with the **TSS** and a D-TEST MODE CONFIRM COMMAND message is received from the **TSS**. If a D-TEST MODE CONFIRM COMMAND message is not received by the time **T-TEST** has expired then the TETRA MS shall exit **TETRA Test mode** and revert back to its **normal operational mode**. The time for **T-TEST** shall be 30 s. This allows time for cell selection and registration to the **TSS** to be completed before the D-TEST MODE CONFIRM COMMAND message is sent, but ensures that the TETRA MS returns to **normal operational mode** if **TETRA test mode** has been inadvertently selected.

A D-TEST MODE CONFIRM COMMAND message requests the TETRA MS to confirm that it has been set to **TETRA Test mode**.

A U-TEST MODE CONFIRM message from the TETRA MS confirms that it is in **TETRA Test mode** (or not). Parameters included with this message shall inform the TSS of the TEI, Power class and Receiver class (A/B/E) of the MS.

In **TETRA Test mode** the TETRA MS shall not send an authentication challenge to the TSS, and the TSS shall not send an authentication challenge to the TETRA MS as it may not have its SIM present (if this is an option) or be programmed with its security information. Air encryption shall not be used. The following MM messages (defined in EN 300 392-2 [1] clause 16 and EN 300 392-7 [13] clause 4) shall be ignored by the MS whilst in **TETRA Test mode**, and should not be sent by the TSS to the MS whilst it is in **TETRA test mode**:

- D-ATTACH/DETACH GROUP IDENTITY;
- D-ATTACH/DETACH GROUP IDENTITY ACKNOWLEDGEMENT;
- D-DISABLE;
- D-ENABLE;
- D-AUTHENTICATION DEMAND;
- D-AUTHENTICATION RESPONSE;
- D-AUTHENTICATION RESULT;
- D-OTAR.

The TETRA MS shall return a U-STATUS message with a failure indication if one of the above messages is received whilst in **TETRA Test mode**.

The TETRA MS shall not send the following MM messages whilst in **TETRA Test mode**:

- U-ATTACH/DETACH GROUP IDENTITY;
- U-ATTACH/DETACH GROUP IDENTITY ACKNOWLEDGEMENT;
- U-AUTHENTICATION RESPONSE;
- U-AUTHENTICATION DEMAND;
- U-AUTHENTICATION RESULT;
- U-OTAR.

The TETRA MS whilst in **TETRA Test mode** shall not action the Supplementary Service (SS) procedure Dynamic Group Number Assignment (DGNA) defined in ETS 300 392-11-22 [14] and ETS 300 392-12-22 [15]. The TETRA MS shall ignore an ASSIGN indication (ETS 300 392-12-22 [15] subclause 5.2.1). Where acknowledgement is required it shall send an ASSIGN-ACK response with the **result for assignment** element (ETS 300 392-12-22 [15] subclause 5.2.2) set to **rejected for any reason**.

When **TETRA Test mode** has been confirmed the TETRA MS shall react to further **TETRA Test (TT) protocol** commands, as well as normal protocol commands (subject to the restrictions described above).

D.3.2.2 Operating TETRA loop back

To operate **TETRA loop back**, a **test call** shall be in an active state.

A D-LOOP COMMAND message requests the TETRA MS to go into **TETRA loop back** mode. A message parameter indicates whether to indicate errors or not (erased frames) in the case of a speech channel. Currently this specification is limited to single slot traffic channels. The TETRA MS shall ignore the D-LOOP COMMAND message if a **test call** is not active, or if **TETRA loop back** mode is already active. To change the loop back type (i.e. to switch between TCH/S with frame erasure and TCH/S without frame erasure) the TSS shall first end the loop back mode which is currently active.

When **TETRA loop back** is operating the TETRA MS shall be in a single slot duplex mode. It is recommended that the TSS does not attempt to change the traffic channel type or to assign the MS to a different frequency channel or TN during **TETRA loop back**.

A U-LOOP CONFIRM message from the TETRA MS confirms that it has set **TETRA loop back**. This message may be sent as unacknowledged data within a layer 2 Basic Link Acknowledge (BL-ACK).

A D-OPEN LOOP COMMAND message from the TSS requests the TETRA MS to end the current **TETRA loop back**.

A U-OPEN LOOP CONFIRM message from the TETRA MS confirms that it has ended **TETRA loop back**. This message may be sent as unacknowledged data within a layer 2 Basic Link Acknowledge (BL-ACK).

D.3.2.3 Ending TETRA Test mode

TETRA Test mode is terminated when the TETRA MS is powered down. It may also be terminated without powering down by some other manual action or over the air interface. On return to **normal operational mode** the TETRA MS shall behave as if it were just powered up and search for a BS with a valid MCC and MNC.

A D-TEST MODE END COMMAND message requests the TETRA MS to revert to **normal operational mode**. To reset **TETRA Test mode** shall now, firstly, require the manual setting procedure.

A U-TEST MODE END CONFIRM message from the TETRA MS confirms that it is reverting to **normal operational mode**.

D.3.3 Bad frame indication

If loopback with frame erasure is active, bad frames detected in a speech channel shall be indicated by replacing the type 1 channel bits for recoding/transmission with a value not valid in normal use. This signal shall be 137 bits each set to '1' for each of speech frames A and B.

The speech channel normally carries two speech frames, A and B, which are coded together; in the event that a bad frame is detected, both A and B frames are erased. In the event that frame stealing is indicated during speech channel loopback testing, the MS shall not attempt to decode and return bits for speech frame B. It is recommended that the TSS does not use the STCH during BER/MER tests on any of the traffic channels.

D.3.4 Channels required to be looped back

Traffic channels to which this loop back mechanism applies are:

- TCH/7,2;
- TCH/4,8 and 1, 4 or 8 blocks interleaving;
- TCH/2,4 and 1, 4 or 8 blocks interleaving;
- TCH/S speech channel without Bad Frame Indication;
- TCH/S speech channel with Bad Frame Indication;

The received traffic channel after decoding, i.e. information type-1 bits in MAC blocks at the TMV-SAP, is re-encoded and returned to the TSS via the air interface. The return channel used is the same type as that received, as configured by the call set-up. For example if the received channel is a TCH/4,8 N = 4 data channel then the decoded 288 type-1 bits of the received MAC block are encoded and returned over a TCH/4,8 N = 4 channel, there will obviously be a delay in returning the signal of at least 4 frames in this case. In the case of the TCH/S, the CRC used for the returned bits is re-calculated from the actual type-1 bits to be returned, so that the information can be correctly received and decoded by the TSS.

D.3.5 TETRA loop back test scenarios

Table D.1 summarizes the expected use of the **TETRA loop back** facility, showing the scenarios for testing a TETRA MS when the TSS is simulating a BS.

Table D.1: MS loop back testing using TETRA Test mode

MS testing Loop back channel	TSS configured as a BS			
	Test signal	Mobile receives	Mobile transmits	General setting of TSS
TCH/7,2 TCH/4,8 TCH/2,4	TCH/x on the RF channel and TN which were set during call set-up	TCH/x from TSS and decodes to MAC blocks at TMV-SAP	Encodes received traffic as a TCH/x There may be a constant delay before retransmission	A standard control frame structure for the MCCH. (note) Calls set up as normal. Unused slots of MCCH RF carrier filled with SCH/HD+SCH/HD (Null PDUs) or BSCH+BNCH
TCH/S with BFI	TCH/S on the RF channel and TN which were set during call set-up	TCH/S from TSS and decodes to MAC blocks at TMV-SAP	Encodes received traffic as a TCH/S except that, where it detects that a received frame is in error, it sets all bits to 1 before encoding. There may be a constant delay before retransmission	
TCH/S without BFI	TCH/S on the RF channel and TN which were set during call set-up	TCH/S from TSS and decodes to MAC blocks at TMV-SAP	Encodes received traffic as a TCH/S, even if a frame in error is detected. There may be a constant delay before retransmission.	
NOTE: When a test call is transferred to a traffic channel on a different RF carrier it is not necessary for the TSS to continue generating an MCCH. When the TETRA equipment is returned to the idle/registered state then an MCCH will be required. This means that the TSS only requires to generate one RF carrier at a time.				

D.4 TETRA Test (TT) PDU descriptions

The TT PDUs detailed in this clause shall be visible at the Um reference point. The general format of the PDU follows that defined in EN 300 392-2 [1] subclauses 14.7 and 16.9. **This clause does not apply to the T1 test mode.**

D.4.1 TT PDU description tables downlink

D.4.1.1 D-LOOP COMMAND

Message: D- LOOP COMMAND.

Response to: -

Response expected: U- LOOP CONFIRM.

Short description: The message is sent by the TSS to request a MS to loop back a channel.

Shown in table D.2:

Table D.2: D-LOOP COMMAND PDU contents

Information element	Length	Type	C/O/M	Remark
PDU Type	5	1	M	
Loopback type	5	1	M	

D.4.1.2 D-OPEN LOOP COMMAND

Message: D-OPEN LOOP COMMAND.

Response to: -

Response expected: U-OPEN LOOP CONFIRM.

Short description: This message is sent by the TSS to a MS to request that any test loop active is opened.

Shown in table D.3:

Table D.3: D-OPEN LOOP COMMAND PDU contents

Information element	Length	Type	C/O/M	Remark
PDU Type	5	1	M	

D.4.1.3 D-TEST MODE CONFIRM COMMAND

Message: D-TEST MODE CONFIRM COMMAND.

Response to: -

Response expected: U-TEST MODE CONFIRM.

Short description: This message is sent by the TSS to a MS to request confirmation that the MS is set to test mode.

Shown in table D.4:

Table D.4: D-TEST MODE CONFIRM COMMAND PDU contents

Information element	Length	Type	C/O/M	Remark
PDU Type	5	1	M	

D.4.1.4 D-TEST MODE END COMMAND

Message: D-TEST MODE END COMMAND.

Response to: -

Response expected: U-TEST MODE END CONFIRM.

Short description: This message is sent by the TSS to a MS to request it to end test mode.

Shown in table D.5:

Table D.5: D-TEST MODE END COMMAND PDU contents

Information element	Length	Type	C/O/M	Remark
PDU Type	5	1	M	

D.4.2 TT PDU description tables uplink

D.4.2.1 U-LOOP CONFIRM

Message: U-LOOP CONFIRM.

Response to: D-LOOP COMMAND.

Response expected: -

Short description: This message is sent by a MS to the TSS to confirm that it has closed the required loop. The loopback type information element is a repeat of that sent on the D-LOOP COMMAND.

Shown in table D.6:

Table D.6: U-LOOP CONFIRM PDU contents

Information element	Length	Type	C/O/M	Remark
PDU Type	5	1	M	
Loopback type	5	1	M	

D.4.2.2 U-OPEN LOOP CONFIRM

Message: U-OPEN LOOP CONFIRM.

Response to: D-OPEN LOOP COMMAND.

Response expected: -

Short description: This message is sent by a MS to the TSS to confirm that the test loop is open.

Shown in table D.7:

Table D.7: U-OPEN LOOP CONFIRM PDU contents

Information element	Length	Type	C/O/M	Remark
PDU Type	5	1	M	

D.4.2.3 U-TEST MODE CONFIRM

Message: U-TEST MODE CONFIRM.

Response to: D-TEST MODE CONFIRM COMMAND.

Response expected: -

Short description: This message is sent by a MS to the TSS to confirm that **TETRA Test mode** has been set.

Shown in table D.8:

Table D.8: U-TEST MODE CONFIRM PDU contents

Information element	Length	Type	C/O/M	Remark
PDU Type	5	1	M	
Confirm	2	1	M	
TETRA equipment identity	60	1	M	15 digit TEI
MS power class	4	1	M	
Receiver class	2	1	M	
Class of MS	24	1	M	(note)
NOTE: Class of MS element is the same as the element used in EN 300 392-2 [1] clause 16.				

D.4.2.4 U-TEST MODE END CONFIRM

Message: U-TEST MODE END CONFIRM.

Response to: D-TEST MODE END COMMAND.

Response expected: -

Short description: This message is sent by a MS to the TSS to confirm that **TETRA Test mode** is ended.

Shown in table D.9:

Table D.9: U-TEST MODE END CONFIRM PDU contents

Information element	Length	Type	C/O/M	Remark
PDU Type	5	1	M	

D.4.3 Information elements coding

Where no description exists below, then the descriptions given in EN 300 392-2 [1] clauses 14 and 16 apply.

D.4.3.1 Loopback type

The purpose of the loopback type element is to inform the TETRA MS whether to indicate frame erasures. This is shown in table D.10:

Table D.10: Loopback type IE contents

Information element	Length	Value	Remark
Loopback type	5		
Current TCH without frame erasure		00001	TCH/S, TCH/7,2, TCH/4,8, TCH/2,4
Current TCH with frame erasure		00010	Current TCH with BFI (note)
NOTE: Frame erasure only applies to TCH/S. In the case of TCH/7,2, TCH/4,8 or TCH/2,4, this value of loopback type shall be treated the same as 'Current TCH without frame erasure'.			

D.4.3.2 Confirm

The purpose of the confirm element is to confirm that the TETRA MS is in **TETRA Test mode** or to indicate that it is not. This is shown in table D.11:

Table D.11: Confirm IE contents

Information element	Length	Value	Remark
Confirm	2	00	confirmed
		01	TETRA Test mode not set
		10	TETRA Test mode not supported
		11	reserved

D.4.3.3 MS power class

The purpose of the MS power element is to inform the TSS of the maximum power output of the MS. This is shown in table D.12:

Table D.12: MS power class IE contents

Information element	Length	Value	Remark
MS power class	4	0001	class 1: 45 dBm
		1001	class 1L: 42,5 dBm
		0010	class 2: 40 dBm
		1010	class 2L: 37,5 dBm
		0011	class 3: 35 dBm
		1011	class 3L: 32,5 dBm
		0100	class 4: 30 dBm
		1100	class 4L: 27,5 dBm
		0101	class 5: 25 dBm
		1101	class 5L: 22,5 dBm

D.4.3.4 PDU

The purpose of the PDU element is to identify the PDU type. This is shown in table D.13:

Table D.13: PDU IE contents

Information element	Length	Value	Downlink	Uplink
PDU	5	00100	D-LOOP COMMAND	
		00101		U-LOOP CONFIRM
		00111	D-OPEN LOOP COMMAND	
		01000		U-OPEN LOOP CONFIRM
		01110	D-TEST MODE CONFIRM COMMAND	
		01111		U-TEST MODE CONFIRM
		10000	D-TEST MODE END COMMAND	
		10001		U-TEST MODE END CONFIRM

D.4.3.5 Receiver class

The purpose of the receiver class element is to inform the TSS of the class of the MS receiver. This is shown in table D.14:

Table D.14: Receiver class IE contents

Information element	Length	Value	Remark
Receiver class	2	00	class A
		01	class B
		10	class E
		11	reserved

D.5 TT use of MLE, LLC and MAC

This clause defines the use of lower layers by the **TETRA Test (TT) protocol** entity. **It does not apply to T1 test mode.**

The TT shall use the services of the Mobile Link Entity (MLE). For the TT the MLE service PDU shall use the TT protocol discriminator 111_2 followed by the TT PDU as defined in EN 300 392-2 [1] subclause 18.5.2.1. The MLE-PDUs are embedded in TL-SDUs and make use of layer 2 processes in a standard manner. The LLC (Logical Link Control) uses the Basic Link PDUs without the frame check sequences (FCS) and the MAC (Medium Access Control) assembles MAC blocks for transmission. The assembly of the PDUs is shown in figure D.3 below.

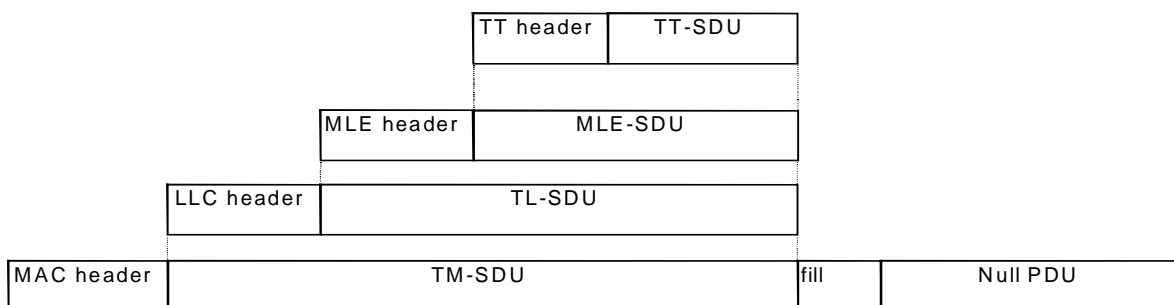

Figure D.3: Relationship between PDUs and SDUs showing how a TT-SDU fits into a MAC block

D.6 Message sequence charts and operation of TETRA loop back

This clause applies to the TETRA Test (TT) protocol. It does not apply to the T1 test mode.

Refer to annex E for an informative description of operation of TETRA loop back.

D.7 Introduction to the T1 Test Mode for RF loop back test

This clause is an introduction to the requirements for a **T1 test mode** for both MS and BS equipment for operation over the TETRA Air Interface (AI). **This clause does not apply to the TETRA Test (TT) Protocol.**

D.7.1 Outline requirements

The **T1 test mode** shall provide the means to activate the **RF loop back** test facility of TETRA MS and BS equipment, thus using the AI and avoiding the use of special test connectors and their associated protocols. It shall enable the following test functions to be performed:

- duplex operation using a single timeslot when in **T1 loopback test mode**, whether or not this is possible in **normal T1 test mode** or **normal operational mode**;
- enable selected received traffic and signalling channels to be decoded and then retransmitted over the air interface on a TCH/7,2 channel.

for TETRA equipment with speech capability (i.e. includes a speech codec):

- enable loop back of speech codec output to the speech codec input (at the 128 kb/s rate).

D.7.2 T1 Test Modes

When in T1 test mode the following sub-modes are required which are selected over the AI:

- **normal T1 test mode:** in this mode the TETRA equipment satisfies the requirements of subclause 5.2. Normal T1 MS test mode is selected by the Loop_back bit of BNCH/T (table A.13) set to zero. Normal T1 BS test mode is selected by the method provided by the manufacturer;
- **T1 loop back test mode:** in this mode the TETRA equipment satisfies the requirements of subclause 5.2.1. Additionally, the MS shall be synchronized in time and frequency to the test signal T1 and shall transmit, only in timeslot 1, TCH/7,2 normal uplink bursts on frames 1 to 17 in every multiframe. The BS shall operate in its normal mode, e.g. continuous or discontinuous mode. For a V+D BS in discontinuous mode the BS shall transmit only in timeslot 1 of each frame. The BS shall transmit, in timeslot 1, TCH/7,2 normal downlink bursts on frames 1 to 17 in every multiframe. For the MS, **T1 loopback test mode** is selected by the Loop_back bit of BNCH/T (table A.13) set to one, regardless of the state of the Tx_on and Tx_burst_type bits of BNCH/T. For the BS, **T1 loopback test mode** is selected by the method provided by the manufacturer. Note that a TETRA MS capable of only simplex operation in its normal mode of functioning shall be capable of duplex functioning in loopback T1 test mode. There are two distinct loop back modes;
- **channel:** the TETRA equipment shall receive the logical channel(s) indicated by the BNCH/T T1_burst_type parameter (table A.13), and after decoding return the contents and error indication (where appropriate) on a TCH/7,2 logical channel.
- **speech:** where the TETRA equipment is capable of supporting TCH/S (i.e. it contains a speech codec), it shall be possible to loop back the received speech traffic at the output of the speech decoder, at the 128kb/s rate, into the input of the speech encoder, for retransmission to the **test system** on a TCH/S logical channel as required by ETS 300 395-4 [8] clause 7. The channel loop back for TCH/S (at the TMV-SAP) and the speech loop back (at the speech codec digital audio interface) shall be mutually exclusive. Thus speech traffic may be looped back after channel decoding (on a TCH/7,2 logical channel) for BER conformance testing, or after speech decoding (on a TCH/S logical channel) for bit-exact speech codec conformance testing.

D.7.3 Switching for loop back test mode

Figure D.4 shows the functional requirements for loop back T1 test modes. The actual physical implementation is left open to the manufacturer. The loop back for the speech encoder/decoder can only be selected when the test mode switch 1 is set to normal.

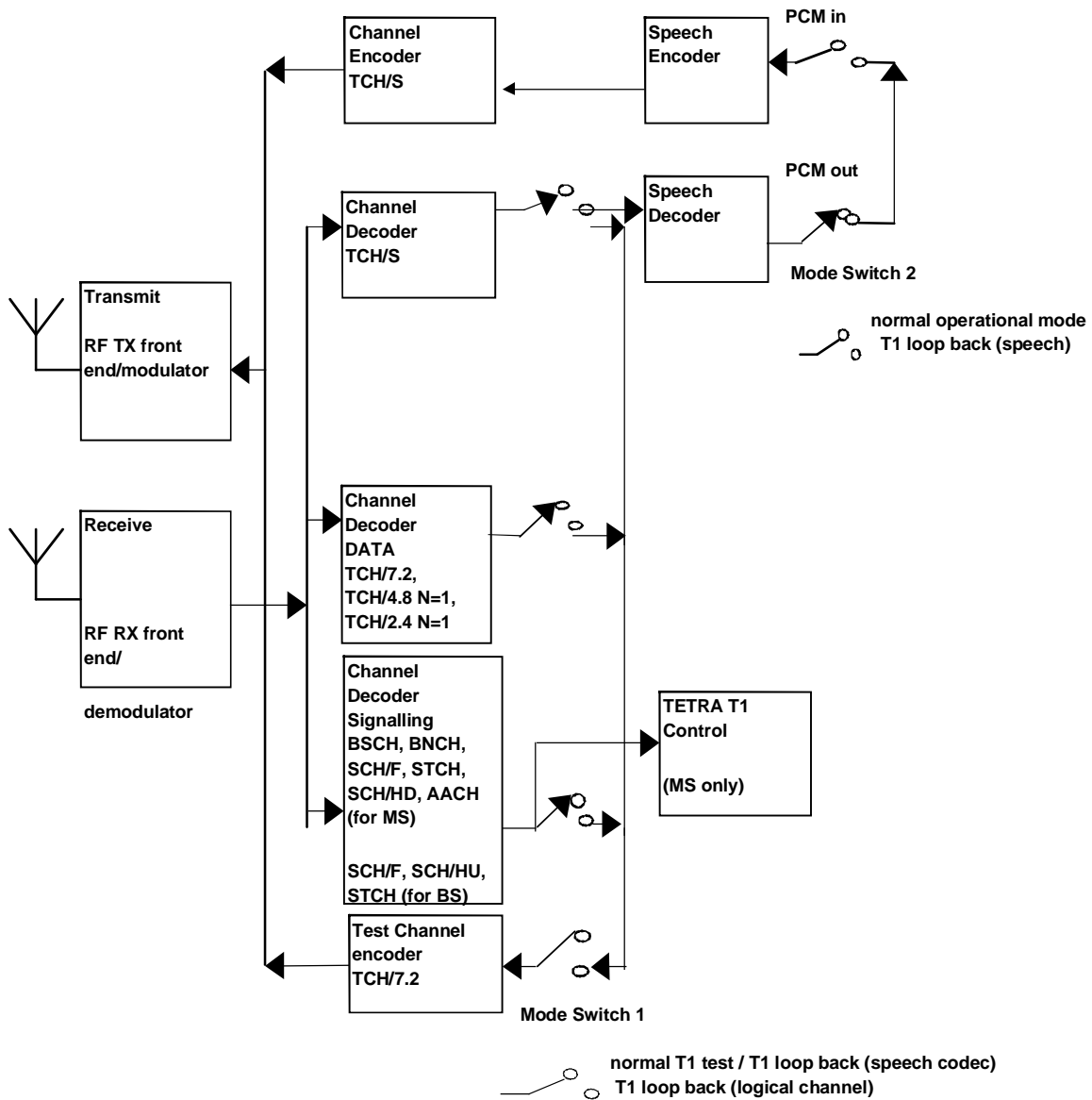

Figure D.4: Functional requirements for MS or BS T1 loop back test mode

D.8 TETRA RF loop back T1 test mode

This clause defines the TETRA RF loop back **T1 test mode**. It does not apply to the TETRA Test (TT) protocol.

D.8.1 Setting TETRA equipment into T1 test mode

Subclause 4.1.1 applies.

With the MS or BS equipment in Test Receive Mode or Test Transmit Mode (subclause 5.2), **T1 loop back test mode** can be selected which shall configure the TETRA equipment to loop back selected channels to the test system without access to special test connectors. This enables the test system to measure receiver performance of the equipment in terms of Bit Error Rate (BER), Probability of Undetected Erroneous Message (PUEM) and Message Erasure Rate (MER). The TETRA equipment shall return test signals via its air interface.

D.8.2 T1 loop back test mode operation

To operate the MS **T1 loop back test mode** over the air interface, the T1 BNCH/T parameters T1_burst_type and Loop_back (table A.13) shall be used to invoke the 'virtual test connector' to provide decoded data output to the **test system** for performing receiver tests using the T1 Test Signal. **T1 loop back test mode** comprises **T1 loopback MS test receive mode** and **T1 loopback MS speech codec test**. When **T1 loopback MS test receive mode** is invoked, the methods described in subclause D.8.4 shall apply. T1 Test Mode operation is summarized in table D.15:

Table D.15: T1 BNCH/T parameter control of MS operation

T1 BNCH/T parameters				MS Operation
Loop_back	Tx_on	Tx_burst_type	T1_burst_type	
0	0	don't care	1, 2, 3, 4, 15, 17	MS test receive mode; decoded data is output on test connector
0	0	don't care	19	MS speech codec test mode; decoded speech is re-coded as TCH/S and output on test connector
0	1	0	don't care	MS test transmit mode; MS transmits normal uplink bursts containing TCH/7,2 PRBS
0	1	1	don't care	MS test transmit mode; MS transmits control uplink bursts in SSN1 containing SCH/HU PRBS
1	don't care	don't care	1, 2, 3, 4, 15, 17	T1 loopback MS test receive mode; decoded data is output on air interface by MS transmitting normal uplink bursts containing TCH/7,2 data
1	don't care	don't care	19	T1 loopback MS speech codec test mode; decoded speech is re-coded as TCH/S and transmitted on TCH/S in normal uplink bursts

To operate the BS **T1 loop back test mode** the BS shall be configured using the method provided by the BS manufacturer.

D.8.3 Logical channels to be looped back

Logical channels to which this loop back mechanism applies are shown in table D.16.

Table D.16: T1 Logical channels testable with RF loop back

T1_burst_type	Logical Channel(s)
Type 1	TCH/7,2 (downlink) + AACH (notes 1 and 2)
Type 2	SCH/F (downlink) + AACH
Type 3	BSCH + SCH/HD (downlink) + AACH (note 1)
Type 4	TCH/2,4 N = 1 (downlink) + AACH
Type 7	TCH/7,2 (uplink)
Type 8	SCH/F (uplink)
Type 9	STCH + STCH (uplink)
Type 10	TCH/2,4 N = 1 (uplink)
Type 11	SCH/HU + SCH/HU
Type 15	TCH/S (downlink) + AACH (note 1)
Type 16	TCH/S (uplink)
Type 17	TCH/4,8 N = 1 (downlink) + AACH (notes 1 and 3)
Type 18	TCH/4,8 N = 1 (uplink) (note 3)
Type 19	TCH/S speech codec test (downlink)
Type 20	TCH/S speech codec test (uplink)
NOTE 1: AACH is only tested (annex A) with type 2 and type 4.	
NOTE 2: RF loopback only returns decoded data for TCH/7,2, not for AACH.	
NOTE 3: TCH/4,8 N = 1 is not tested (annex A).	

D.8.4 Return channel for logical channel loop back

The received logical channel(s) which are to be looped back are decoded to the MAC block type-1 bits level at the TMV-SAP. The decoded type-1 bits are returned to the **test system** over the air interface in a TCH/7,2 as follows.

The channel used to loop back the requested logical channels shall be a TCH/7,2. This channel is encoded normally as in EN 300 392-2 [1] clause 8, that is the 432 bits are only scrambled. In the case of the MS the scrambling code shall be the current extended colour code as defined by the BSCH information generated by the **test system** T1 signal generator. In the case of the BS the scrambling code shall be the current extended colour code as defined by the BSCH information generated by the BS.

The TCH/7,2 data is contained in Normal Uplink Bursts (for the MS) or Normal Downlink Bursts (for the BS) transmitted in FN 1 to FN 17 in TN 1 only. In the case of the BS, the AACH data in the BBK of these bursts is undefined.

The general method of assembling the return data is shown in figure D.5:

Full slot or 1st subslot or 1st block information	Fill	2nd subslot or 2nd block information if applicable	Fill	AACH MS only	E3	E2	E1
---	------	--	------	--------------	----	----	----

Figure D.5: General structure of returned signalling information

The E1, E2 and E3 fields are single bit indications of an error state detected by the receiver on test (e.g. parity check wrong). The bit is set to 1 to indicate an error and 0 for no error detected or not applicable:

- E1 applies to the full slot or SS1/BKN1 information;
- E2 applies to SS2/BKN2 information when applicable;
- E3 applies to the AACH logical channel information.

The use of the 432 input bits to the channel is defined in individual subclauses D.8.4.1 to D.8.4.13. The notation used for the bits is that used in EN 300 392-2 [1] clause 8. When no burst has been received where one was expected, the returned bits shall be set to all zeroes, except for the error bits which shall be set to ones.

D.8.4.1 Type 1: TCH/7,2 + AACH

When the T1 BNCH/T information requests a downlink Type 1 channel to be looped back, the received channel in BKN1 and BKN2 is unscrambled. The resultant 432 bits received ($b_1(1), b_1(2), \dots, b_1(432)$) are included in a TCH/7,2 block as shown in figure D.6. The received AACH in BBK, which is 14 bits after error decoding ($b_1(1), b_1(2), \dots, b_1(14)$), is unable to be included with the looped back information in this case, and is discarded. The order of the bits is shown in figure D.6 - note that this does not follow the general method shown in figure D.5 as there is no AACH data and there are no E1 / E2 / E3 bits:

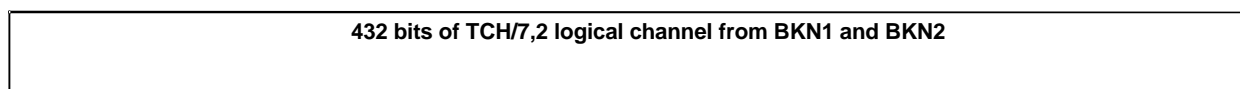

Figure D.6: Returned data for Type 1: TCH/7,2 + AACH

D.8.4.2 Type 2: SCH/F + AACH

When the T1 BNCH/T information requests a downlink Type 2 channel to be looped back, the received channel in BKN1 and BKN2 is unscrambled, de-interleaved, decoded and parity checked. The resultant 268 bits received ($b_1(1), b_1(2), \dots, b_1(268)$) are included in a TCH/7,2 block as shown in figure D.7. The received AACH in BBK, which is 14 bits after error decoding ($b_1(1), b_1(2), \dots, b_1(14)$), is included with the looped back information along with any error indications in E1 and E3. Fill bits and error bit E2 are set to zero. The order of the bits is shown in figure D.7:

268 bits of SCH/F logical channel	Fill 147 bits	AACH 14 bits	E3 1 bit	E2 1 bit	E1 1 bit
-----------------------------------	------------------	-----------------	-------------	-------------	-------------

Figure D.7: Returned data for SCH/F + AACH

D.8.4.3 Type 3: BSCH + SCH/HD + AACH

When the T1 BNCH/T information requests a downlink Type 3 channel to be looped back, the BSCH channel in the first block of the Synchronization Burst is unscrambled, de-interleaved, decoded and parity checked. The resultant 60 bits received ($b_1(1), b_1(2), \dots, b_1(60)$) are included in a TCH/7,2 block as shown in figure D.8. The SCH/HD contained in BKN2 is decoded and the 124 bits ($b_1(1), b_1(2), \dots, b_1(124)$) are also returned. The received AACH in BBK, which is 14 bits after error decoding ($b_1(1), b_1(2), \dots, b_1(14)$), is included with the looped back information along with any error indications in E1, E2 and E3. Fill bits are set to zero. The return TCH/7,2 channel shall be scrambled using the existing extended colour code, i.e. the PRBS content of the BSCH shall not be interpreted as new values of MCC / MNC / BCC. The order of the bits is shown in figure D.8.

60 bits BSCH logical channel	Fill 156 bits	SCH/HD logical channel 124 bits	Fill 75 bits	AACH 14 bits	E3 1 bit	E2 1 bit	E1 1 bit
------------------------------	---------------	---------------------------------	--------------	--------------	----------	----------	----------

Figure D.8: Returned data for BSCH + SCH/HD + AACH

D.8.4.4 Type 4: TCH/2,4 N = 1 + AACH

When the T1 BNCH/T information requests a downlink Type 4 channel to be looped back, the received channel in BKN1 and BKN2 is unscrambled, de-interleaved and decoded. The resultant 144 bits received ($b_1(1), b_1(2), \dots, b_1(144)$) are included in a TCH/7,2 block as shown in figure D.9. The received AACH in BBK, which is 14 bits after error decoding ($b_1(1), b_1(2), \dots, b_1(14)$), is included with the looped back information along with any error indication in E3. Fill bits and error bits E1 and E2 are set to zero. The order of the bits is shown in figure D.9.

144 bits of TCH/2,4 N=1 logical channel	Fill 271 bits	AACH 14 bits	E3 1 bit	E2 1 bit	E1 1 bit
---	---------------	--------------	----------	----------	----------

Figure D.9: Returned data for Type 4: TCH/2,4 N = 1 + AACH

D.8.4.5 Type 7: TCH/7,2 (uplink)

When the BS configuration requests an uplink Type 7 channel to be looped back, the received channel in BKN1 and BKN2 is unscrambled. The resultant 432 bits received ($b_1(1), b_1(2), \dots, b_1(432)$) are included in a TCH/7,2 block as shown in figure D.10. The order of the bits is shown in figure D.10 - note that this does not follow the general method shown in figure D.5 as there are no E1 / E2 / E3 bits.

432 bits of TCH/7,2 logical channel from BKN1 and BKN2
--

Figure D.10: Returned data for Type 7: TCH/7,2 (uplink)

D.8.4.6 Type 8: SCH/F (uplink)

When the BS configuration requests an uplink Type 8 channel to be looped back, the received channel in BKN1 and BKN2 is unscrambled, de-interleaved, decoded and parity checked. The resultant 268 bits received ($b_1(1), b_1(2), \dots, b_1(268)$) are included in a TCH/7,2 block as shown in figure D.11, along with any error indication in E1. Fill bits and error bits E2 and E2 are set to zero. The order of the bits is shown in figure D.11.

268 bits of SCH/F logical channel	Fill 161 bits	E3 1 bit	E2 1 bit	E1 1 bit
-----------------------------------	---------------	----------	----------	----------

Figure D.11: Returned data for SCH/F (uplink)

D.8.4.7 Type 9: STCH + STCH (uplink)

When the BS configuration requests an uplink Type 9 channel to be looped back, the received channel in BKN1 is unscrambled, de-interleaved, decoded and parity checked. The resultant 124 bits received ($b_1(1), b_1(2), \dots, b_1(124)$) are included in a TCH/7,2 block as shown in figure D.12. BKN2 is also decoded as STCH and included in the TCH/7,2 block, along with any error indications in E1 and E2. The fill bits and error bit E3 are set to zero. The order of the bits is shown in figure D.12.

124 bits of STCH logical channel Fill from BKN1	92 bits	124 bits from STCH logical channel from BKN2	Fill 89 bits	E3 1 bit	E2 1 bit	E1 1 bit
--	---------	--	--------------	-------------	-------------	-------------

Figure D.12: Returned data for STCH + STCH (uplink)

D.8.4.8 Type 10: TCH/2,4 N = 1 (uplink)

When the BS configuration requests an uplink Type 10 channel to be looped back, the received channel in BKN1 and BKN2 is unscrambled, de-interleaved and decoded. The resultant 144 bits received ($b_1(1), b_1(2), \dots, b_1(144)$) are included in a TCH/7,2 block as shown in figure D.13. Fill bits and error bits are set to zero. The order of the bits is shown in figure D.13.

144 bits of TCH/2.4 N=1 logical channel	Fill 285 bits	E3 1 bit	E2 1 bit	E1 1 bit
---	------------------	-------------	-------------	-------------

Figure D.13: Returned data for Type 10: TCH/2,4 N = 1 + AACH

D.8.4.9 Type 11: SCH/HU + SCH/HU

When the BS configuration requests an uplink Type 11 channel to be looped back, then, if present, the received channel in SS1 is unscrambled, de-interleaved, decoded and parity checked. The resultant 92 bits received ($b_1(1), b_1(2), \dots, b_1(92)$) are included in a TCH/7,2 block as shown in figure D.14 below, along with any error indication in E1. If the second half of the received slot SS2 contains a SCH/HU the decoded 92 bits ($b_1(1), b_1(2), \dots, b_1(92)$) are returned, along with any error indication in E2. Fill bits and error bit E3 are set to zero. The order of the bits is shown in figure D.14 below.

92 bits from SCH/HU logical channel in subslot 1	Fill 124 bits	92 bits from SCH/HU logical channel in subslot 2	Fill 121 bits	E3 1 bit	E2 1 bit	E1 1 bit
--	------------------	--	------------------	-------------	-------------	-------------

Figure D.14: Returned data for SCH/HU + SCH/HU

D.8.4.10 Type 15: TCH/S + TCH/S + AACH

When the T1 BNCH/T information requests a downlink Type 15 channel to be looped back, the received channel in BKN1 and BKN2 is unscrambled, de-interleaved and decoded. The resultant 2×137 bits received ($b_1(1), b_1(2), \dots, b_1(137)$) are included in a TCH/7,2 block as shown in figure D.15. The received AACH in BBK, which is 14 bits after error decoding ($b_1(1), b_1(2), \dots, b_1(14)$), is included with the looped back information along with any error indications in E1 and E3. Fill bits and error bit E2 are set to zero. The order of the bits is shown in figure D.15.

TCH/S logical channel 137 bits Speech Sample A	Fill 79 bits	TCH/S logical channel 137 bits Speech Sample B	Fill 62 bits	AACH 14 bits	E3 1 bit	E2 1 bit	E1 1 bit
---	--------------	---	-----------------	-----------------	-------------	-------------	-------------

Figure D.15: Returned data for TCH/S + TCH/S + AACH

D.8.4.11 Type 16: TCH/S + TCH/S (uplink)

When the BS configuration requests an uplink Type 16 channel to be looped back, the received channel in BKN1 and BKN2 is unscrambled, de-interleaved and decoded. The resultant 2×137 bits received ($b_1(1), b_1(2), \dots, b_1(137)$) are included in a TCH/7,2 block as shown in figure D.16, along with any error indication in E1. Fill bits and error bits E2 and E3 are set to zero. The order of the bits is shown in figure D.16.

TCH/S logical channel 137 bits Speech Sample A	Fill 79 bits	TCH/S logical channel 137 bits Speech Sample B	Fill 76 bits	E3 1 bit	E2 1 bit	E1 1 bit
---	--------------	---	-----------------	-------------	-------------	-------------

Figure D.16: Returned data for TCH/S + TCH/S (uplink)

D.8.4.12 Type 17: TCH/4,8 N = 1 + AACH

When the T1 BNCH/T information requests a downlink Type 17 channel to be looped back, the received channel in BKN1 and BKN2 is unscrambled, de-interleaved and decoded. The resultant 288 bits received ($b_1(1), b_1(2), \dots, b_1(288)$) are included in a TCH/7,2 block as shown in figure D.17. The received AACH in BBK, which is 14 bits after error decoding ($b_1(1), b_1(2), \dots, b_1(14)$), is included with the looped back information along with any error indication in E3. Fill bits and error bits E1 and E2 are set to zero. The order of the bits is shown in figure D.17.

288 bits of TCH/4,8 N=1 logical channel	Fill 127 bits	AACH 14 bits	E3 1 bit	E2 1 bit	E1 1 bit
---	------------------	-----------------	-------------	-------------	-------------

Figure D.17: Returned data for Type 17: TCH/4,8 N = 1 + AACH

D.8.4.13 Type 18: TCH/4,8 N = 1 (uplink)

When the BS configuration requests an uplink Type 18 channel to be looped back, the received channel in BKN1 and BKN2 is unscrambled, de-interleaved and decoded. The resultant 288 bits received ($b_1(1), b_1(2), \dots, b_1(288)$) are included in a TCH/7,2 block as shown in figure D.18. Fill bits and error bits are set to zero. The order of the bits is shown in figure D.18.

288 bits of TCH/4,8 N=1 logical channel	Fill 141 bits	E3 1 bit	E2 1 bit	E1 1 bit
---	------------------	-------------	-------------	-------------

Figure D.18: Returned data for Type 18: TCH/4,8 N = 1 (uplink)

D.8.4.14 Type 19: TCH/S speech codec test (downlink)

This T1 type is intended for performing bit-exact speech codec tests. When the T1 BNCH/T information requests a downlink Type 19 channel to be looped back, the received channel in BKN1 and BKN2 is unscrambled, de-interleaved and decoded. The resultant 2×137 bits received ($b_1(1), b_1(2), \dots, b_1(137)$) are decoded by the speech codec as 60 ms of speech in the form of 480×16 -bit linear PCM samples. These PCM samples are re-encoded by the speech codec to form 2×137 bits ($b_1(1), b_1(2), \dots, b_1(137)$) which are coded, interleaved, scrambled and included in a TCH/7,2 block as shown in figure D.19. The received AACH in BBK is discarded. The order of the bits is shown in figure D.19.

432 bits of TCH/S logical channel from BKN1 and BKN2, decoded and re-encoded by speech codec and channel codec
--

Figure D.19: Returned data for Type 19: TCH/S speech codec test (downlink)

D.8.4.15 Type 20: TCH/S speech codec test (uplink)

This T1 type is only applicable to a BS which includes a speech codec, or which is connected to a speech codec for testing purposes. When the BS configuration requests an uplink type 20 channel to be looped back, the received channel in BKN1 and BKN2 is unscrambled, de-interleaved and decoded. The resultant 2×137 bits received ($b_1(1), b_1(2), \dots, b_1(137)$) are decoded by the speech codec as 60 ms of speech in the form of 480×16 -bit linear PCM samples. These PCM samples are re-encoded by the speech codec to form 2×137 bits ($b_1(1), b_1(2), \dots, b_1(137)$) which are coded, interleaved, scrambled and included in a TCH/7,2 block as shown in figure D.20. The order of the bits is shown in figure D.20.

432 bits of TCH/S logical channel from BKN1 and BKN2, decoded and re-encoded by speech codec and channel codec

Figure D.20: Returned data for Type 20: TCH/S speech codec test (uplink)

D.8.5 Loop back test scenarios

Tables D.17 and D.18 summarize the expected use of the T1 loop back facility. Table D.17 shows the scenarios for testing a TETRA MS when the TSS is generating a downlink T1 signal. Table D.18 shows the scenarios for testing a TETRA BS when the BS is generating a downlink T1 signal and the TSS is generating an uplink T1 signal synchronized to the BS.

Table D.17: MS T1 loop back testing

MS testing	TSS configured as a downlink T1 signal generator			
	Loop back channel(s)	Test signal	Mobile receives	Mobile transmits
TCH/x + AACH	T1 type 1, 4, 15 or 17 on the required RF channel	TN1 frames 1 to 17 decoded as TCH/x + AACH to MAC blocks at TMV-SAP	Formats received logical channels and errors as defined in subclause D.8.4 and transmits as TCH/7,2 on	T1 signal as defined in subclause 5.3.2
SCH/F + AACH	T1 type 2 on the required RF channel	TN1 frames 1 to 17 decoded as SCH/F + AACH to MAC blocks at TMV-SAP	TN1 frames 1 to 17. There may be a constant delay between reception and retransmission, as well as allowance for frame 18	T1 signal as defined in subclause 5.3.2
BSCH + SCH/HD + AACH	T1 type 3 on the required RF channel	TN1 frames 1 to 17 decoded as BSCH + SCH/HD + AACH to MAC blocks at TMV-SAP		T1 signal as defined in subclause 5.3.2
Speech codec bit-exact conformance test	T1 type 19 on the required RF channel containing TCH/S codec test vectors	TN1 frames 1 to 17 decoded as TCH/S to 128kbit/s PCM at speech decoder output	Encodes received 128kbit/s at speech encoder input and transmits as a TCH/S. There may be a constant (and frame 18) delay before retransmission	T1 signal type 19, containing codec test vectors instead of PRBS.

Table D.18: BS T1 loop back testing

BS testing	TSS configured as uplink T1 signal generator, synchronized to BS			
Loop back channel(s)	Test signal	BS receives	BS transmits	General setting of TSS
TCH/x	T1 type 7, 10, 16 or 18 on uplink RF channel	TN1 frames 1 to 17 decoded as TCH/x to MAC blocks at TMV-SAP	Formats received logical channel and errors as defined in subclause D.8.4 and transmits as TCH/7,2 on TN1 frames 1 to 17.	Uplink T1 signal synchronized to downlink T1 signal generated by BS under test
SCH/F	T1 type 8 on uplink RF channel	TN1 frames 1 to 17 decoded as SCH/F to MAC blocks at TMV-SAP	There may be a constant delay between reception and retransmission, as well as allowance for frame 18	Uplink T1 signal synchronized to downlink T1 signal generated by BS under test
STCH + STCH	T1 type 9 on uplink RF channel	TN1 frames 1 to 17 decoded as STCH + STCH to MAC blocks at TMV-SAP		Uplink T1 signal synchronized to downlink T1 signal generated by BS under test
SCH/HU + SCH/HU	T1 type 11 on uplink RF channel	TN1 frames 1 to 17 decoded as SCH/HU + SCH/HU to MAC blocks at TMV-SAP		Uplink T1 signal synchronized to downlink T1 signal generated by BS under test
BS Speech codec bit-exact conformance test (requires codec in BS or attached to it)	T1 type 20 on uplink RF channel containing TCH/S codec test vectors	TN1 frames 1 to 17 decoded as TCH/S to 128kbit/s PCM at speech decoder output	Encodes received 128kbit/s at speech encoder input and transmits as a TCH/S. There may be a constant (and frame 18) delay before retransmission	T1 signal type 20, containing codec test vectors instead of PRBS.

D.9 Direct Mode Operation (DMO)

This section is informative only at present. The DMO specifications (ETS 300 396-1 [9], ETS 300 396-2 [10], ETS 300 396-3 [11]) were not complete at the time of writing this specification. It is likely that DMO equipment will be some or all of the following combinations of capability (ETS 300 396-1 [9] clause 4):

- DO-MS: Direct mode Only MS;
- DU-MS: DUal mode switchable MS;
- DW-MS: Dual Watch MS;
- DM-REP: Direct Mode REPeater;
- DM-GATE: Direct Mode GATEway;
- DM-REP/GATE Direct Mode REPeater/GATEway.

Also combinations of these may be possible. RF testing, using the loop back facilities given in this specification, may follow the scenarios given below.

D.9.1 DO-MS

Continuous loop back in direct mode operation is not possible, because operation of traffic channels is in a true simplex mode, The same RF carrier and timeslot combination is used in both directions of a communication. Some form of store and return mechanism in a DO-MS will be required in test mode to enable air interface loop back to be used.

D.9.2 DU-MS

Loop back testing can be performed with the mode switched to V+D. As it is unlikely that the RF circuitry will change when the mode is switched to DMO, only a functional test will be required in DMO mode.

D.9.3 DW-MS

Loop back testing can be performed with V+D operation activated. As it is unlikely that the RF circuitry will change when the DMO mode is active, only a functional test will be required for DMO operation.

D.9.4 DM-REP

The specifications here are not yet complete. However the operation of a repeater is to forward the information from one Direct Mode MS (DM-MS) to another DM-MS, thus if the TSS transmit section acts as the sending DM-MS and the TSS receive section acts as the receiving DM-MS a natural loop back is formed and a test mode will only be required to override authentication and encryption procedures. For TCH/S BER testing it may be necessary to disable the repeater's normal Bad Frame Erasure operation.

D.9.5 DM-GATE

The specifications here are not yet complete. However the operation of a gateway is to forward the information from a DM-MS to a SwMI (or vice versa), thus if the TSS transmitter acts as the sending DM-MS and the TSS receiver acts as the receiving BS (or vice versa) a natural loop back is formed. The test mode will only be required to indicate bad frames and bar authentication and encryption procedures.

D.9.6 DM-REP/GATE

The comments for DM-REP and DM-GATE apply.

D.9.7 DMO summary

The specification is adequate in its present form for all types of DMO equipment with the exception of DO-MS. If the DO-MS type of equipment is manufactured, then additions to the specification as indicated above will be required.

Annex E (informative): Using RF loop back to test a TETRA MS

Annex E applies to the **TETRA Test (TT) Protocol** Loopback method defined in clauses D.1 to D.6. Annex E does not apply to the T1 Loopback method defined in clauses D.7 and D.8.

E.1 Introduction

The purpose of the **RF loop back** facility using the **TT protocol** is to provide a consistent method for assessing BER and MER on TETRA mobile stations, in production and service environments, without the need for special test connectors or adapters.

The present document is a guide to how the **RF loop back** facility may be used to test a TETRA MS. A simplified view of the test configuration during RF loop back testing is shown in figures E.1 and E.2:

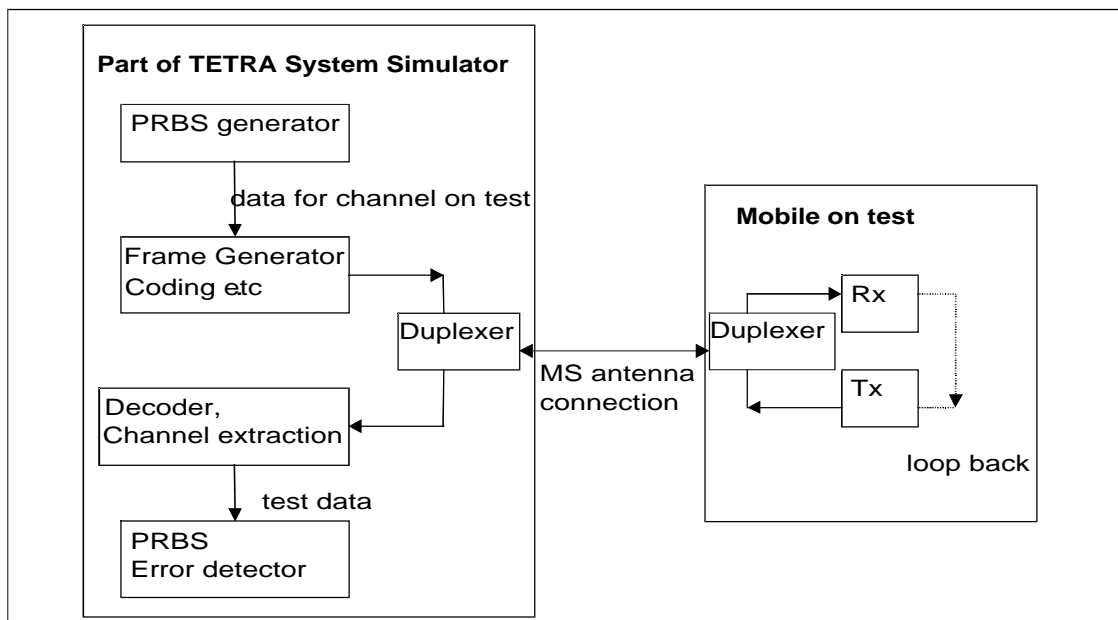

Figure E.1: RF Loop Back test configuration

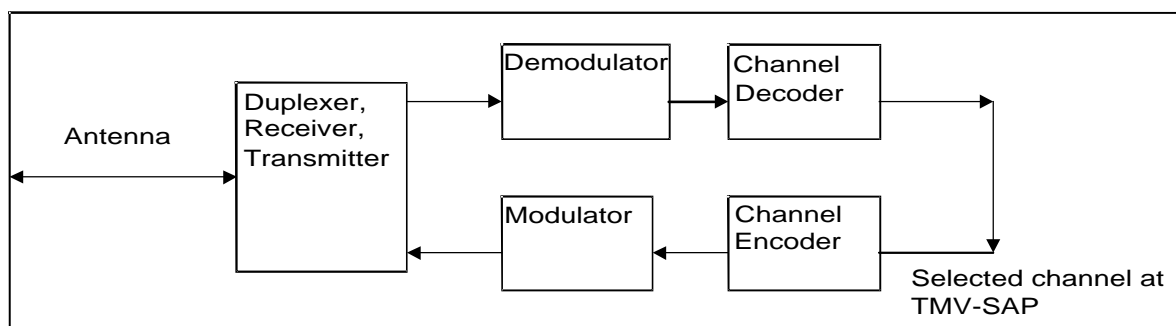

Figure E.2: Simplified diagram of MS during RF Loop Back

The message sequence and broadcast parameters used in the document are intended as an illustration of one possible sequence of messages and set of parameters. It is not intended to restrict the range of options used by mobile manufacturers. It is the responsibility of the **TETRA System Simulator (TSS)** designers to ensure that valid messages from the unit on test are correctly acknowledged and answered.

E.2 Expected mode of operation for testing a MS

To test a TETRA MS the TSS (acting as a base station) shall as a minimum generate in Downlink Continuous Transmission mode (D-CT) in a Normal Control mode (NC) with a Main Control Channel (MCCH) in time slot 1 of the main carrier.

A Broadcast Control Channel (BCCH) comprising a Broadcast Synchronization Channel (BSCH) and a Broadcast Network Channel (BNCH) shall be transmitted as a minimum to the requirements of EN 300 392-2 [1], subclause 9.5.2.

Table E.1a: Example of use of TETRA frame structure for mobile testing

	TN1 (CP)	TN2 (UP)	TN3 (UP or TP)	TN4 (UP)
MN1 FN1 to FN17 see note	SCH/HD (null) + SCH/HD (null) <i>or signalling</i> + AACH	SCH/HD (null) + SCH/HD (null) + AACH	SCH/HD (null) + SCH/HD (null) <i>or TCH/x</i> + AACH	SCH/HD (null) + SCH/HD (null) + AACH
MN1 FN18	SCH/HD (null) + SCH/HD (null) + AACH	BSCH (sync info) + SCH/HD (null) + AACH (CLCH)	SCH/HD (null) + SCH/HD (null) + AACH	SCH/HD (null) + BNCH (sys info) + AACH
MN2 FN1 to FN17	SCH/HD (null) + SCH/HD (null) <i>or signalling</i> + AACH	SCH/HD (null) + SCH/HD (null) + AACH	SCH/HD (null) + SCH/HD (null) <i>or TCH/x</i> + AACH	SCH/HD (null) + SCH/HD (null) + AACH
MN2 FN18	BSCH (syncinfo) + SCH/HD (null) + AACH (CLCH)	SCH/HD (null) + SCH/HD (null) + AACH	SCH/HD (null) + BNCH (sys info) + AACH	SCH/HD (null) + SCH/HD (null) + AACH
MN3 FN1 to FN17	SCH/HD (null) + SCH/HD (null) <i>or signalling</i> + AACH	SCH/HD (null) + SCH/HD (null) + AACH	SCH/HD (null) + SCH/HD (null) <i>or TCH/x</i> + AACH	SCH/HD (null) + SCH/HD (null) + AACH
MN3 FN18	SCH/HD (null) + SCH/HD (null) + AACH	SCH/HD (null) + BNCH (sys info) + AACH	SCH/HD (null) + SCH/HD (null) + AACH	BSCH (sync info) + SCH/HD (null) + AACH (CLCH)
MN4 FN1 to FN17	SCH/HD (null) + SCH/HD (null) <i>or signalling</i> + AACH	SCH/HD (null) + SCH/HD (null) + AACH	SCH/HD (null) + SCH/HD (null) <i>or TCH/x</i> + AACH	SCH/HD (null) + SCH/HD (null) + AACH
MN4 FN18	SCH/HD (null) + BNCH (sys info) + AACH	SCH/HD (null) + SCH/HD (null) + AACH	BSCH (sync info) + SCH/HD (null) + AACH (CLCH)	SCH/HD (null) + SCH/HD (null) + AACH

NOTE 1: This structure of four multiframes MN1 ~ MN4 is repeated x15 to form one Hyperframe, with the Multiframe Number (MN) taking the values 1, 2, 3, 4, 5, 6, 7, 8, ..., 57, 58, 59, 60.

NOTE 2: Mandatory mappings of BNCH, BSCH and opportunities for CLCH are shown in **bold** type.

An example of how the TSS structure might look is shown in table E.1a. Here a minimum requirement is shown; there is a single RF channel with MCCH on TN1. Signalling such as registration and call set up (and mobile initial access) will be on TN1. When a traffic channel is required (in this example) it will use TN3; TN2 and TN4 are not used and transmit null PDUs. (This is only one of many examples that could be described, but this example has the benefit of simplicity and single RF channel usage).

The Access Assignment Channel (AACH) shall allow sufficient opportunities for linearization and opportunities for a mobile to access the TSS.

Currently unallocated physical channels (UP) shall be filled with permitted logical control channels as indicated in EN 300 392-2 [1], subclauses 9.5.2 and 9.5.3. In this simple example a SCH/HD containing a null PDU is used as follows in table E.1b.

Table E.1b: Contents of SCH/HD when used as a fill signal

Parameter	Bits	Value	Remarks
NULL PDU			
PDU type	2	00 ₂	MAC_RESOURCE
Fill bits	1	0 ₂	no fill bits
Position of grant	1	0 ₂	don't care
Encryption	2	00 ₂	No encryption
Random Access Flag	1	0 ₂	
Length	6	000010 ₂	2 octets (null PDU)
Address type	3	000 ₂	Null PDU
Fill	108	100...0 ₂	1+107 0s

The contents of the TM_SDU(MLE_SYNC) and SYNC_PDU used for the BSCH are given in table E.2.

Table E.2: Contents of SYNC_PDU

Parameter	Bits	Value	Remarks
SYNC_PDU			
System code	4	0000 ₂	1 st release V+D
Base Colour Code	6	01 - 63	as required
Timeslot number	2		current timeslot
Frame number	5		current frame number
Multiframe number	6		current MF number
Sharing mode	2	00 ₂	continuous TX
TS reserved frames	3	000 ₂	don't care
U-plane DTX	1	0 ₂	not allowed
Frame 18 extension	1	0 ₂	no extension
Reserved	1	0 ₂	default
TM_SDU (D_MLE_SYNC)			
Mobile Country Code	10	001 ₁₆	MCC=001 for test
Mobile Network Code	14	0001 ₁₆	MNC =1 for test
Neighbour cell broadcast			
D_NWRK_BROADCAST			
supported	1	0 ₂	not supported
enquiry	1	0 ₂	not supported
Cell service level	2	00 ₂	cell load unknown
Late entry information	1	0 ₂	not supported

The contents of the TM_SDU (MLE_SYSINFO) and SYSINFO_PDU used for the BNCH are given in table E.3 below.

Table E.3: Contents of SYSINFO PDU

Parameter	Bits	Value	Remarks
SYSINFO_PDU			
PDU type	2	10 ₂	Broadcast PDU
Broadcast type	2	00 ₂	SYSINFO PDU
Main carrier	12		as required
Frequency band	4		as required
Offset	2	00 ₂	0kHz offset
Duplex spacing	3		as required
Reverse operation	1		as required
No. of common 2ndry CCHs in use	2	00 ₂	none
MS_TXPWR_MAX_CELL	3	001 ₂	15dBm default or as required
RXLEV_ACCESS_MIN	4	0000 ₂	-125dBm default or as required
ACCESS_PARAMETER	4	0000 ₂	-53dB default or as required
RADIO_DOWNLINK_TIMEOUT	4	0000 ₂	disabled default or as required
Hyperframe/CCK flag	1	0 ₂	hyperframe
Hyperframe number	16		current HF number
Optional field flag	2	10 ₂	access code A
<i>Default definition for access code A</i>			
IMM (immediate)	4	1111 ₂	immediate access
WT (waiting time)	4		as required
Nu (access attempts)	4		as required
Framelength factor	1	0 ₂	multiply by 1
Timeslot pointer	4	0000 ₂	same as downlink
Minimum priority	3	000 ₂	lowest priority (0)
<i>TM_SDU (MLE_SYSINFO)</i>			
Location area	14	?	as required
Subscriber class	16	FFFF ₁₆	all classes
BS service details			
Registration	1	1 ₂	registration mandatory
De-registration	1	1 ₂	de-registration mandatory
Priority cell	1	1 ₂	priority cell
Minimum mode service	1	0/1 ₂	as required
Migration	1	1 ₂	supported
Roaming	1	1 ₂	supported
TETRA voice service	1	1 ₂	supported
Circuit mode data service	1	1 ₂	supported
CONP service	1	0/1 ₂	as required
SCLNP service	1	0/1 ₂	as required
Air interface encryption	1	0 ₂	not available
Advanced link supported	1	0/1 ₂	as required

The Access Assignment Channel (AACH) during this initial period will allow access to all mobiles during Frames 1 to 17 on TN1, allow linearization on all Frame 18s containing a BSCH, and on other frames will mark the AACH as access reserved.

Initially, TN1 frames may be marked access reserved, to enable the TSS to control when the first access burst is sent, but this would need to be carefully handled to stop the TETRA equipment on test timing out because it had not confirmed the test mode setting.

As a minimum requirement, Access Code A is required, and in a test situation this will normally be the only Access Code used. Base frame length will be kept to a minimum to ensure fast test times. Initially, four AACH types are required; see tables E.4, E.5, E.6 and E.7. Once messages are exchanged, other AACH values will be required.

Table E.4: AACH Frame 1 to 17 TN1

Information element	Value	Remark
Header	00 ₂	Downlink usage common control Uplink access rights - common only
Access field 1- Access code Base framelength	00 ₂ 0011 ₂	Access code A Base framelength 1 subslot
Access field 2- Access code Base framelength	00 ₂ 0011 ₂	Access code A Base framelength 1 subslot

Table E.5: AACH Frame 1 to 17 TN2, 3 and 4

Information element	Value	Remark
Header	11 ₂	Downlink usage defined by field 1 Uplink usage rights defined by field 2
Field 1-Downlink usage marker	000000 ₂	Unallocated
Field 2-Uplink usage marker	000000 ₂	Unallocated

Table E.6: AACH Frame 18 TN1, 2, 3 and 4 (not containing BSCH)

Information element	Value	Remark
Header	00 ₂	Uplink access rights - common only
Access field 1- Access code Base framelength	00 ₂ 0000 ₂	Access code A Reserved subslot
Access field 2- Access code Base framelength	00 ₂ 0000 ₂	Access code A Reserved subslot

Table E.7: AACH Frame 18 TN1, 2, 3 and 4 (containing BSCH)

Information element	Value	Remark
Header	00 ₂	Uplink access rights - common only
Access field 1- Access code Base framelength	00 ₂ 0001 ₂	Access code A CLCH subslot
Access field 2- Access code Base framelength	00 ₂ 0000 ₂	Access code A Reserved subslot

The output level of the **TSS** shall be adjusted to give a suitable input level to the MS on test. This should initially be in the range -90 to -60 dBm, to ensure error free registration and test mode confirmation.

E.3 Recognition of TETRA Test mode by MS

The mobile is switched on and set to **TETRA Test mode**. This could be, for example, by pressing a sequence of keys in a manner similar to calling up a supplementary service, e.g. *99*.

On recognizing that it has been set to **TETRA Test mode** the mobile shall immediately start timer **T_TEST**. It shall then search for a MCCH with a MCC of 001 and a MNC of 1.

When allowed by the **TSS**, the mobile shall attempt to register with the **TSS**. It shall not attempt to authenticate the **TSS** or use encryption on the air interface.

The first message sent by the mobile shall be a MAC ACCESS in a control burst with the MM layer 3 message U_LOCATION_UPDATE_DEMAND. It will treat the **TSS** as a visited location and the address type it shall use shall be the USSI (migrating MS unexchanged address) this will normally be the same as its ISSI (individual short subscriber identity). In a case where the mobile has yet to be given an ITSI (individual TETRA subscriber identity) an address of all 0s may be used.

The registration with identity exchange procedure then continues, as indicated in ETS 300 392-1 [12] subclause 9.6.1.2.1, with the **TSS** simulating the base station and SwMI. Details of the message contents are to be found in EN 300 392-2 [1] subclauses 16.9.2 and 16.9.3.

The procedure is successfully completed when the **TSS** has sent a **D_LOCATION_UPDATE_ACCEPT** message which the mobile has acknowledged. The **TSS** shall then send a TT layer 3 message **D_TEST_MODE_CONFIRM_COMMAND** which the mobile acknowledges with a **TEST_MODE_CONFIRM** message. At this point the mobile shall stop timer **T_TEST** and go into the test mode operating state.

During this procedure the **TSS** will use the **MAC_RESOURCE** header and modify the **AACH** to reserve subslots to allow the mobile to transmit, and indicate when messages are being sent to the mobile. The use of the **AACH** shall be as given in the TETRA specification EN 300 392-2 [1] subclause 21.4.7.

In **TETRA Test mode** the MS shall accept and generate all normal valid commands, with the exception of some Mobility Management (MM) commands and with the addition of commands with the TT protocol discriminator, some of the exceptions being:

- it shall not action a **D_DISABLE** command neither temporary nor permanent;
- it shall not encrypt messages on the air interface;
- it shall not attempt to authenticate the **TSS**.

The full list of exceptions is given in subclause D.3.2.1.

If the timer **T_TEST** expires before the above procedure is completed then the mobile shall revert to **normal operational mode** i.e. start searching for a control channel allowed by its subscription parameters. To retry to set into test mode would require the user to set test mode again, i.e. in the example the key sequence *99* would need entering again.

With the test mode confirmed the mobile shall be in the idle and registered state listening for paging messages etc. It shall also have the ability to place and answer calls. If the MS has any kind of visual display, it should indicate that it is set in test mode. This could be for example by displaying the word 'TEST' in the display panel, or for a MS with no display panel this could be by flashing an indicator light in a particular manner.

E.4 Using loop back to test traffic channels

To test a mobile on a traffic channel, for example to perform a BER test, requires that an individual call be in progress and then a **RF loop back** invoked. The call can be placed from the **TSS** or the mobile.

Where the mobile has duplex capability, the call shall be set up in duplex mode. To maintain the channel during a simplex call, message trunking is used. Message trunking is indicated by the **MAC_RESOURCE** PDU at an "over" when the PDU does not have a channel allocation returning the mobile back to the **MCCH**. In the simple scenario described the traffic channel will be allocated to **TN3** on the main carrier.

To invoke the loop back a **D_LOOP_COMMAND** message is sent to the mobile, this shall indicate that the (current) traffic channel is to be looped back. The message may indicate in the 'loopback type' element that **BFI** (bad frame indication) is to be used; this only applies to a speech traffic channel and the 'loopback type' element should be ignored for data traffic channels. The mobile shall respond with a **U_LOOP_CONFIRM** message. The mobile shall also loop the received traffic channel to the transmitter as indicated in the main text of this specification. During loop back the traffic channel received is decoded to type-1 bits at the **TMV-SAP** level and then the type-1 bits are re-encoded and returned on an identical traffic channel to the **TSS**.

3 examples are outlined below:

- TCH/7,2;
- TCH/S;
- TCH/2,4 with N = 8.

During the call the **TSS** shall use normal procedures on the **AACH**, this shall normally involve allocating a usage marker to the call and marking, via the **AACH**, the uplink and downlink slots to be used with the usage marker.

During loop back the uplink and downlink slots shall be marked for use as a traffic channel, via the AACH. In the example considered the AACH will mark all TN3 slots, both uplink and downlink, of the main carrier in frames 1 to 17 with the usage marker allocated for the call.

The loop back command is "carried" in a MAC_RESOURCE PDU and for the case where a simplex call is in progress the channel allocation element shall allocate the resources for both up and down link. See tables E.8 and E.9 for typical messages.

Table E.8: Example of loop command in MAC_RESOURCE enabling duplex operation

Parameter	Bits	Value	Remarks
MAC_RESOURCE PDU			
PDU type	2	00 ₂	MAC_RESOURCE
Fill bit indicator	1	0 ₂	fill bits not present
Position of grant	1	1 ₂	on allocated channel
Encryption mode	2	00 ₂	not encrypted
Random access flag	1	0 ₂	don't care
Length indication	6	001100 ₂	12 bytes
Address type	3	110 ₂	SSI + usage marker assignment
Address	30	x...x ₂	SSI + usage marker
Power control flag	1	0 ₂	no power control (may be used if required)
Slot granting flag	1	0 ₂	no slot granting element
Channel allocation flag	1	1 ₂	channel allocation follows
Channel allocation element			
Allocation type	2	00 ₂	replace current channel with specified channel
Time slot assigned	4	0010 ₂	TN 3 assigned (or as required)
Up/downlink assigned	2	11 ₂	both uplink and downlink assigned
CLCH permission	1	1 ₂	immediate permission
Cell change flag	1	0 ₂	no cell change
Carrier number	12	x...x ₂	as required (the channel in current use)
Extended carrier number flag	1	0 ₂	no extended carrier numbering
Monitoring pattern	2	00 ₂	no monitoring pattern
Frame 18 monitoring pattern	2	11 ₂	3 monitoring patterns (all frame 18s)
TM_SDU (D_LOOP COMMAND)			
LLC header			
LLC PDU type	4	0000 ₂	BL_ADATA without FCS
N(R)	1	1/0 ₂	as required
N(S)	1	1/0 ₂	as required
MLE header			
Protocol discriminator	3	111 ₂	TETRA Test entity
TT PDU			
PDU type	5	00100 ₂	D_LOOP COMMAND
Loopback type	5	00001 ₂	current TCH without frame erasure
O_bit	1	0 ₂	optional elements not present
Null PDU			
PDU type	2	00 ₂	MAC_RESOURCE
Fill bit indicator	1	0 ₂	none
Position of grant	1	0 ₂	don't care
Encryption mode	2	00 ₂	not encrypted
Random access flag	1	0 ₂	don't care
Length indication	6	000010 ₂	null PDU (2 bytes)
Address type	3	000 ₂	null PDU
Fill bits	12	100000 ₂ 000000 ₂	required to pad out to 124 bits for SCH/HD

Table E.9: Example of a MAC block containing a TT U-TEST MODE CONFIRM PDU

	Information element	Length	C/O/M	Remarks
MAC HEADER	PDU type	2	M	MAC-DATA = 00
	Fill bit indication	1	M	Fill bits not present = 0
	Encrypted flag	1	M	Not encrypted = 0
	Address type	2	M	SSI = 00
	Address	24	M	ASSI
	Length indication or capacity request	1	M	Length indication next = 0
	Length indication	6	C	Length of MAC header + TM SDU 15 octets in this example = 001111
LLC HEADER	LLC PDU type	4	M	BL-ADATA without FCS = 0000
	N(R)	1	M	1 or 0 as appropriate
	N(S)	1	M	1 or 0 as appropriate
MLE HEADER	Protocol Discriminator	3	M	Tetra Test entity = 111
TT PDU	PDU type	5	M	10001=U-TEST MODE CONFIRM
	Confirm	2	M	00 = confirmed
	TETRA equipment identity	60	M	15 digit TEI
	MS power class	4	M	e.g. 0011 = class 3
	Receiver class	2	M	e.g. 01 = class B
	O_bit	1	M	0 = optional elements not present
	NULL PDU	PDU type	2	M
Fill bit indication		1	M	Fill bits present = 1
Encrypted flag		1	M	Not encrypted = 0
Address type		2	M	SSI = 00
Address		24	M	ASSI
Length indication or capacity request		1	M	Length indication next = 1
Length = Null PDU		6	M	000000 = null PDU
Fill bits		111	C	'1' + 110 '0's
Total MAC block		268		
M = mandatory C = conditional O = optional				

E.4.1 TCH/7,2

The **TSS** shall take 432 bits from a repeated standard 511 bit PRBS; it shall scramble the bits according to EN 300 392-2 [1], subclause 8.2.5.2. These scrambled bits shall form the 2 blocks BKN1 and BKN2 which shall be transmitted in a normal continuous downlink burst forming part of the downlink traffic channel (TN3 frames 1 to 17 in the simple scenario considered). The **TSS** shall then take the next 432 bits of the PRBS and repeat the process to produce the next burst in the traffic channel.

The mobile shall receive the bursts containing the traffic channel and extract the 432 bits of the blocks BKN1 and BKN2 and de-scramble them. These recovered 432 bits are re-scrambled and shall form the 2 blocks BKN1 and BKN2 which shall be transmitted in a normal discontinuous uplink burst. (This conceptually loops back the signal at the TMV-SAP point, the same result is achieved if the scrambled received bits are used to form the two blocks BKN1 and BKN2 for retransmission). Although ideally the loop backed signal should occur in the same frame as it was received, a constant delay is acceptable.

While in loop back it shall be optional whether the mobile delivers the 7,2 kb/s data to the user.

The **TSS** shall receive the burst with the returned traffic channel and extract the 432 bits of the blocks BKN1 and BKN2 and de-scramble them. The resulting 432 bits shall be checked for errors, the errors shall be totalled over a number of returned bursts of the traffic channel to enable the BER to be calculated.

E.4.2 TCH/S

The **TSS** shall take 2 contiguous samples of 137 bits from a repeated standard 511 bit PRBS, these shall represent 2 frames from a speech encoder. Sample 1 forms the Type-1 bits A1,..., A137, sample 2 forms the Type-1 bits B1,..., B137. The bits are then reordered, parity and tail bits added, convolution coding applied, interleaved and finally scrambled (naming and numbering notation and coding procedure is that used in ETS 300 395-2 [17] clause 5). The 432 scrambled bits shall form the 2 blocks BKN1 and BKN2 which shall be transmitted in a normal continuous downlink burst forming part of the downlink traffic channel (TN3 frames 1 to 17 in the simple scenario considered). The **TSS** shall then take the next 2 contiguous samples of 137 bits of the PRBS and repeat the process to produce the next burst in the traffic channel.

The mobile shall receive the bursts containing the traffic channel and extract the 432 bits of the blocks BKN1 and BKN2 and decode them. The result after de-scrambling, de-interleaving and de-convolution shall be 286 type-2 bits. The 60 class 2 bits shall have their parity bits calculated and checked against the received parity bits. If the parity bits do not match then this shall be an indication of a bad frame for when this is required. The type 1 bits shall be extracted from the type-2 bits. The resulting 2 speech frames are used as the inputs to the encoding process (This conceptually loops back the signal at the TMV-SAP point, the same result is achieved if the type-2 bits are looped back with parity bits recalculated). The speech frames are encoded and the resulting 432 bits shall form the 2 blocks BKN1 and BKN2 which shall be transmitted in a normal discontinuous uplink burst. Although ideally the looped back signal should occur in the same frame as it was received, a constant delay is acceptable.

In the case where the D_LOOP_COMMAND message has requested BFI the return signal may be modified. If the parity check on the class 2 bits fail or some other indication of an unusable traffic sample is indicated by the mobile and BFI is requested then the two return samples should be set to all 1s prior to encoding for retransmission.

While in loop back it shall be optional whether the mobile delivers "speech" to the user. (It is probably advisable not to "deliver" the speech to avoid uncomfortable noises to any listener).

The **TSS** shall receive the burst with the returned traffic channel and extract the 432 bits of the blocks BKN1 and BKN2 and decode them. The resulting two 137 bit speech frames shall be checked for errors; the errors shall be totalled over a number of returned bursts of the traffic channel to enable the BER to be calculated. Where BFI has been requested the **TSS** shall recognize the samples set to all 1s as bad frames, calculating the BER only in those frames which do not indicate BFI.

E.4.3 TCH/2,4, N = 8

The **TSS** shall take 144 bits from a repeated standard 511 bit PRBS, it shall add 4 tail bits and RCPC (convolution) code with $r = 148/432$. The resultant 432 bit type-3 bits are interleaved over 8 blocks. A completed block shall contain an equal number of convoluted bits from 8 samples of the PRBS. Each completed block of 432 bits is further interleaved to form the type-4 bits which shall then be scrambled (these processes are according to EN 300 392-2 [1], clause 8). These scrambled bits shall form the 2 blocks BKN1 and BKN2 which shall be transmitted in a normal continuous downlink burst forming part of the downlink traffic channel (TN3 frames 1 to 17 in the simple scenario considered). The **TSS** shall continue taking contiguous 144 bit samples of the PRBS and repeat the processes described.

The mobile shall receive the bursts containing the traffic channel and extract the 432 bits of the blocks BKN1 and BKN2 and de-scramble them. The bits shall be block de-interleaved, then the information shall be further de-interleaved over the 8 blocks originally contributing to the block. When an originating block is completed it shall be de-convoluted and the tail bits removed to obtain the 144 data bits. The recovered data along with other retrieved samples shall then be re-encoded as described for the **TSS** for retransmission. (This conceptually loops back the signal at the TMV-SAP point.

While in loop back it shall be optional whether the mobile delivers the 2,4kb/s data to the user.

The **TSS** shall receive the burst with the returned traffic channel and extract the 432 bits of the blocks BKN1 and BKN2 and de-scramble them etc. The resulting 144 type-1 bits shall be checked for errors, the errors shall be totalled over a number of returned bursts of the traffic channel to enable the BER to be calculated. Interleaving over 8 blocks causes an overall delay of at least 16 frames between the original sample and the received sample for checking. The delay may be longer but shall be constant.

E.4.4 Control messages during loop back of traffic channels

During the period in which error tests are in progress, there shall normally be no control messages sent. If however the **TSS** requires to send a control message, for example to request a change in power level, the burst containing the message will have training sequence number 2 indicating channel stealing (STCH). The mobile shall decode and action the message, it may stop, temporarily, the loop back mechanism until the signalling sequence is completed i.e. the message has been acknowledged or answered. It is the responsibility of the **TSS** to allow for this interruption in any error counting procedure etc.

If during the loop back the mobile transmits a control message, for example an attempt to invoke a supplementary service is made, the **TSS** shall acknowledge the message and may indicate to the test operator via the **TSS** MMI that an unexpected interruption has occurred. Whether the test in progress is terminated, repeated or continued depends on the type of interruption and is a matter for the designer of the **TSS**.

Annex F (normative): Direct Mode (DMO) Conformance Testing

F.1 Scope

Annex F defines the test limits and measurement methods to be used for the conformance testing of radio aspects of TETRA terminals which are capable of operating in Direct Mode Operation (DMO). It applies to all six types of Direct Mode terminal defined in ETS 300 396-1 [9] (DO-MS, DU-MS, DW-MS, DM-REP, DM-GATE, DM-REP/GATE).

F.2 Definitions, symbols and abbreviations

Refer to ETS 300 396-1 [9] and ETS 300 396-2 [10] for common definitions.

F.3 General

With the exception of DO-MS equipment, all equipment which is capable of DMO is also capable of normal trunked mode V+D operation, and therefore has to pass the radio aspects conformance tests in this specification. DO-MS equipment is required by ETS 300 396-2 [10] to fulfil most of the radio requirements of trunked mode Class B V+D MS equipment, the main exceptions being power control and reception of the AACH logical channel. Therefore, this annex requires all equipment which is capable of DMO to meet this specification, with certain exceptions for DO-MS equipment.

NOTE: If manufacturers produce DO-MS equipment which is designed specifically as DO-MS (rather than being a DU-MS with the V+D operation disabled in software) then it is possible that this equipment will not be physically capable of operating in the frequency duplex mode required to conduct tests under clauses 8 to 10. In this case, further DO-MS specific tests may be required.

Equipment which is capable of DMO is required by ETS 300 396-2 [10] to meet slightly more stringent test limits for transmitter output power below maximum power class. Therefore, this annex requires all equipment which is capable of DMO to meet this specification using the more stringent limits where applicable.

Direct Mode Operation involves two radio aspects which are not covered by this specification, unsynchronized transmission and direct mode burst profiles. Therefore, this annex requires all equipment which is capable of DMO to provide an additional DMO Test Transmit Mode, and to meet the requirements of two additional tests.

F.4 Radio Test Modes

For the purpose of testing, all equipment which is capable of DMO shall provide test modes which enable all of the MS V+D tests in clauses 8, 9 and 10 to be performed as specified (see note below), except as shown in table F.1, and shall also provide a DMO test transmit mode as defined in subclause F.6.1.

Table F.1: Test Case Exceptions for equipment capable of Direct Mode Operation

Subclause	Equipment Type	Test Case Exception
8.1.1 a)	DO-MS (one power class)	The DO-MS shall disregard the T1 level, Access_parameter and MS_TXPWR_MAX_CELL parameters, and shall set its transmitter output power to its nominal power class.
8.1.1 a)	DO-MS (more than one power class)	The DO-MS shall either set its power according to test case 1 or shall be switched to its highest power class.
8.1.1 c)	DO-MS (one power class)	The test shall not be repeated for test cases 2 to 7.
8.1.1 c)	DO-MS (more than one power class)	All of the other power classes shall be tested by the DO-MS either setting its power according to test cases 2 to 7 as appropriate, or by being switched to its other power classes.
8.3	DO-MS (one power class)	The test shall not be repeated for test case 7.
8.3	DO-MS (more than one power class)	The test shall be repeated by the DO-MS either setting its lowest power class in response to test case 7 or by being switched to its lowest power class.
10.5	DO-MS	This test shall not be performed.
NOTE:	The T1 signal supplied shall be identical to the normal T1 signal used for V+D testing. FN18 will contain BSCH (not SCH/S) scrambled with all-zeroes scrambling code, and BNCH/T (not SCH/H) scrambled with the normal extended colour code obtained from the BSCH (not all zeroes scrambling code). The bursts transmitted by the DM-MS in this test mode shall be Normal Uplink Bursts or Control Bursts as indicated in the BNCH/T information (not the Direct Normal Burst and Direct Synchronization Burst).	

F.5 Test Conditions

All equipment which is capable of DMO shall be tested according to clauses 8, 9, 10 and 11, except as shown in table F.1, and shall meet the test limits defined in clause 7, except as shown in table F.2.

Table F.2: Test Limit Exceptions for equipment capable of Direct Mode Operation

Subclause	Equipment Type	Test Limit Exception
7.1.1.2	All types	The limits for the MS power class (specified in ETS 300 396-2 [10] clause 6) apply to all power levels tested which correspond to power classes of the equipment.
7.1.5.2	All types	See note 1
7.2.2.2	DO-MS	Table A.2 applies (as MS receiver V+D Class B, see note 2)
7.2.3.2	DO-MS	Table A.2 and table A.11 apply (as MS receiver V+D Class B, see note 2), but with no requirement to measure AACH
7.2.4.2	DO-MS	Table A.2 applies (as MS receiver V+D Class B, see note 2)
7.2.5.2	DO-MS	Table A.2 applies (as MS receiver V+D Class B)
7.2.6.2	DO-MS	Table A.2 applies (as MS receiver V+D Class B)
7.2.7.2	DO-MS	Table A.2 applies (as MS receiver V+D Class B)
<p>NOTE 1: In the case where a DM-MS transmits on a DM channel frequency which is within its normal V+D MS Tx band, then the limits shall apply symmetrically to both sides of the MS Tx band, where f_{rb} denotes the frequency offset corresponding to the near edge of the received band or 5MHz (10 MHz for frequencies above 520 MHz) whichever is greater. All levels are expressed in dBc relative to the actual transmitted power level, and in any case no limit tighter than -55 dBm for offsets $\leq f_{rb}$ or -70 dBm for offsets $> f_{rb}$ shall apply.</p> <p>In other cases, the -100 dBc requirement shall apply outside of the frequency range f_x which comprises the range of frequencies over which the equipment is able to transmit within the TETRA standard, plus a guard band of 5 MHz on either side as shown in ETS 300 396-2 [10] figure 6. In any case no limit tighter than -70 dBm shall apply.</p> <p>NOTE 2: Where propagation condition TU50 is specified in table A.2 and table A.11 the test shall be performed using propagation condition DR50 defined in ETS 300 396-2 [10] clause 6.</p>		

F.6 Additional Tests for equipment which is capable of Direct Mode Operation

F.6.1 DMO Test transmit mode

The manufacturer shall provide the means to operate the equipment under test in DMO test transmit mode over the frequency range which includes at least the declared DMO RF carrier frequency range. DMO test transmit mode shall be selected using the method provided by the manufacturer.

In DMO test transmit mode, the equipment under test shall be configured to transmit a signal as follows. In timeslot 1 of frame 18, a Direct Synchronization Burst (DSB) containing SCH/S and SCH/H information shall be transmitted. In timeslot 1 of frames 1 to 17, a Direct Normal Burst (DNB) containing channel type 1 (TCH/7,2) information shall be transmitted. In timeslots 2 to 4 of frames 1 to 18, nothing shall be transmitted, except that the equipment may transmit a DSB in timeslot 3 of frames 6, 12 and 18, and a linearization burst in timeslot 3 of frame 3. This sequence may be preceded by continuous DSB transmission. A bit stream, produced by repeating a pseudo random sequence with a length of 511 bits according to ITU-T Recommendation O.153 [3], shall be used as the information to be transmitted over the TCH/7,2 logical channel.

The equipment shall set its transmit power according to its DMO power class, specified in ETS 300 396-2 [10] clause 6. If the equipment has more than one DMO power class, the highest power class shall be selected using the method provided by the manufacturer.

In DMO test transmit mode, the equipment under test is not provided with a test signal from the test system, and derives its frequency and timing information from its own internal frequency reference.

F.6.2 DMO transmitter output power profile

F.6.2.1 DMO transmitter output power profile, limit values

The following requirement shall be met.

The transmitter output power versus time shall be within the power time mask specified in ETS 300 396-2 [10], clause 6, figure 7, measured through the TETRA filter under normal test conditions. The time periods t_1 , t_2 and t_3 in ETS 300 396-2 [10], clause 6, figure 7 are defined in ETS 300 396-2 [10], clause 6, table 6.

F.6.2.2 DMO transmitter output power profile, method of measurement

This test shall be performed under normal test conditions specified in clause 6, on the middle radio frequency channel in the band in which the equipment is intended for DMO.

- a) The DMO equipment shall be connected to the test system, and shall be placed in DMO test transmit mode on its highest DMO power class.
- b) The sampling system shall capture a representation of the DMO transmit burst's amplitude and timing (excluding any LCH transmissions). The procedure shall be repeated for 200 bursts and the test system shall calculate the following two parameters:
 - b1) the average power versus time profile during time periods t_1 and t_3 (figure 7 in ETS 300 396-2 [10]), extended at least 5 symbol periods before the start of t_1 and at least 5 symbol periods after the end of t_3 , sampled at a rate equal to or greater than the symbol rate, where each point represents the average power per sample, as estimated from the 200 arrays;
 - b2) the average power over the useful part of a burst (the modulation symbol times SN_0 to SN_{max} defined in ETS 300 396-2 [10] clause 9), sampled at symbol rate at symbol time, further averaged over the 200 burst measurements. This single power value shall be used as the 0 dB reference for the power versus time profile determined in step b1) above.

F.6.3 DMO Carrier frequency accuracy

F.6.3.1 DMO Carrier frequency accuracy, limit values

The carrier frequency error in any burst shall be within $\pm 1,0$ kHz measured under normal and extreme test conditions.

F.6.3.2 DMO Carrier frequency accuracy, method of measurement

This test shall be performed under normal and extreme test conditions specified in clause 6, on the middle radio frequency channel in the band in which the equipment is intended for DMO. The measurement described here is performed on direct mode normal bursts, defined in ETS 300 396-2 [10], clause 9. The sampling system in annex B, subclause B.1.2 shall be employed.

- a) The DMO equipment shall be connected to the test system, and shall be placed in DMO test transmit mode on its highest DMO power class.
- b) The sampling system shall capture a representation of the DMO transmit burst's modulation symbol $Z(k)$ at sampling times t_k (symbol by symbol) where t_k is the symbol time corresponding to the k^{th} symbol. For each symbol the sampling system shall measure the phase rotation θ which is caused by the frequency difference between the DMO equipment and the sampling system, as defined in ETS 300 396-2 [10], clause 6. The sampling system shall calculate the frequency error (df) for the burst as follows:

$$df = 1/(2\pi T \text{SNmax}) \sum_{k=1}^{\text{SNmax}} \theta(k)$$

where df is expressed in Hz, T is the symbol duration in s, $\theta(k)$ is expressed in radians, and SNmax is the number of symbols in a burst, defined in ETS 300 396-2 [10], clause 9.

- c) The procedure described in step b) shall be repeated for 20 bursts.

F.6.4 DM-MS Slave synchronization accuracy

F.6.4.1 DM-MS Slave synchronization accuracy, definition

DM-MS slave synchronization accuracy (error) is defined as a difference between the actual transmitted carrier frequency and the nominal synchronized carrier frequency, where the nominal synchronized carrier frequency is defined as the nominal transmit carrier frequency subject to the same frequency variation as the carrier frequency of the signal received by the DM-MS.

- NOTE: When the DM-MS equipment is required to transmit in slave mode, it is important that it synchronizes with and transmits back to the master on the master's frequency and timing. This happens, for example, during pre-emption request, changeover request (when the channel is reserved), timing change request, responding to call set-up with presence check and when responding to acknowledged short data message.

F.6.4.2 DM-MS Slave synchronization accuracy, limit values

The DM-MS slave synchronization accuracy in any burst shall be within ± 100 Hz, measured under normal test conditions.

F.6.4.3 DM-MS Slave synchronization accuracy, method of measurement

- a) The test system shall transmit test signal T1 at a carrier frequency which is varied by +1,0 kHz from the nominal carrier frequency, using a frequency reference for the timebase used to generate the modulation symbols which is varied by +2,0 ppm.
- b) The test defined in 10.2.1 shall be performed using the T1 signal subject to frequency variation as defined in step a).
- c) Steps a) and b) shall be repeated with a carrier frequency variation of -1,0 kHz and a timebase frequency reference variation of -2,0 ppm.

Annex G (normative): TETRA EMC requirements related to the antenna port and emissions from the enclosure of the radio equipment

Table G.1: Clauses and/or subclauses of the present document relevant for compliance with essential requirements of the EC Council Directives

Clause/subclause number and title		Corresponding article of Council Directive 89/336/EEC [18]
7.1.5	Unwanted emissions far from the carrier	4(a)
7.1.6	Unwanted radiated emissions	4(a)
7.2.8	Unwanted conducted emissions	4(a)
7.2.9	Unwanted radiated emissions	4(a)
7.2.5	Blocking characteristics	4(b)
7.2.6	Spurious response rejection	4(b)
NOTE:	These EMC requirements are only those related to the antenna port and emissions from the enclosure of the radio equipment. The remaining TETRA EMC requirements are defined in ETS 300 827 [16].	

History

Document history		
Edition 1	March 1996	Publication as ETS 300 394-1
	September 2000	According to EPT#12 decision, TS 100 394-1 was created, when EN 300 394-1 was sent to Vote.
V2.1.1	September 2000	Publication