

**Universal Mobile Telecommunications System (UMTS);
QoS optimization for AAL type 2 connections
over Iub and Iur interfaces
(3GPP TR 25.934 version 4.0.0 Release 4)**



Reference

DTR/TSGR-0325934Uv4

Keywords

UMTS

ETSI

650 Route des Lucioles
F-06921 Sophia Antipolis Cedex - FRANCE

Tel.: +33 4 92 94 42 00 Fax: +33 4 93 65 47 16

Siret N° 348 623 562 00017 - NAF 742 C
Association à but non lucratif enregistrée à la
Sous-Préfecture de Grasse (06) N° 7803/88

Important notice

Individual copies of the present document can be downloaded from:

<http://www.etsi.org>

The present document may be made available in more than one electronic version or in print. In any case of existing or perceived difference in contents between such versions, the reference version is the Portable Document Format (PDF). In case of dispute, the reference shall be the printing on ETSI printers of the PDF version kept on a specific network drive within ETSI Secretariat.

Users of the present document should be aware that the document may be subject to revision or change of status. Information on the current status of this and other ETSI documents is available at <http://www.etsi.org/tb/status/>

If you find errors in the present document, send your comment to:
editor@etsi.fr

Copyright Notification

No part may be reproduced except as authorized by written permission.
The copyright and the foregoing restriction extend to reproduction in all media.

© European Telecommunications Standards Institute 2001.

All rights reserved.

Intellectual Property Rights

IPRs essential or potentially essential to the present document may have been declared to ETSI. The information pertaining to these essential IPRs, if any, is publicly available for **ETSI members and non-members**, and can be found in ETSI SR 000 314: "*Intellectual Property Rights (IPRs); Essential, or potentially Essential, IPRs notified to ETSI in respect of ETSI standards*", which is available from the ETSI Secretariat. Latest updates are available on the ETSI Web server (<http://www.etsi.org/ipr>).

Pursuant to the ETSI IPR Policy, no investigation, including IPR searches, has been carried out by ETSI. No guarantee can be given as to the existence of other IPRs not referenced in ETSI SR 000 314 (or the updates on the ETSI Web server) which are, or may be, or may become, essential to the present document.

Foreword

This Technical Report (TR) has been produced by the ETSI 3rd Generation Partnership Project (3GPP).

The present document may refer to technical specifications or reports using their 3GPP identities, UMTS identities or GSM identities. These should be interpreted as being references to the corresponding ETSI deliverables.

The cross reference between GSM, UMTS, 3GPP and ETSI identities can be found under www.etsi.org/key.

Contents

Foreword	4
Introduction	4
1 Scope	5
2 References	5
3 Definitions, symbols and abbreviations	6
3.1 Definitions	6
3.2 Symbols	6
3.3 Abbreviations	6
4 Issue to be improved	7
4.1 Priority capability in Release 99	7
4.1.1 Prioritisation at AAL type 2 level	7
4.1.1.1 I.363.2 ^[2]	7
4.1.2 Prioritisation at ATM level	7
4.1.2.1 Q.2630.1 ^[5]	7
4.2 Required instantaneous bit rate	7
5 UTRAN transport network configuration	9
5.1 Direct connection	10
5.3 AAL type 2 switch	11
6 Solution for QoS optimization of AAL type 2 connection	11
6.1 Priority capability in Q.2630.2 ^[6] (Q.aal2 CS2)	11
6.1.1 Path type capability	11
6.1.2 Application of Q.2630.2 ^[6] onto UTRAN transport network	12
6.1.2.1 Direct and ATM switch cases	12
6.1.2.2 AAL type 2 switch case	13
6.2 Other solution	13
7 Backward compatibility	13
7.1 Backward compatibility between Q.2630.1 ^[5] and Q.2630.2 ^[6]	13
8 Change request	14
8.1 Q.2630.1 ^[5] to Q.2630.2 ^[6]	14
8.2 Path Type parameter	14
8.3 I.363.2 (09/97) ^[2] to Revised I.363.2 (11/2000) ^[3]	15
8.4 Handling of other new capabilities in Q.2630.2 ^[6]	15
Annex A: Change history	16

Foreword

This Technical Report has been produced by the 3rd Generation Partnership Project (3GPP).

The contents of the present document are subject to continuing work within the TSG and may change following formal TSG approval. Should the TSG modify the contents of the present document, it will be re-released by the TSG with an identifying change of release date and an increase in version number as follows:

Version x.y.z

where:

- x the first digit:
 - 1 presented to TSG for information;
 - 2 presented to TSG for approval;
 - 3 or greater indicates TSG approved document under change control.
- y the second digit is incremented for all changes of substance, i.e. technical enhancements, corrections, updates, etc.
- z the third digit is incremented when editorial only changes have been incorporated in the document.

Introduction

The present document is to proceed the Release 4 work task “QoS optimization of AAL type 2 connections over Iub and Iur interfaces”.

1 Scope

The present document clarifies:

- the issue to be improved under the work task,
- requirements for the solution from UTRAN transport network configuration point of view,
- solution to solve the issue,
- backward compatibility mechanism between Release 4 and Release 99 specifications for the solution, and
- what Change request is needed to reflect the solution to enhance Release 99 specifications to Release 4 specifications.

2 References

The following documents contain provisions which, through reference in this text, constitute provisions of the present document.

- References are either specific (identified by date of publication, edition number, version number, etc.) or non-specific.
- For a specific reference, subsequent revisions do not apply.
- For a non-specific reference, the latest version applies. In the case of a reference to a 3GPP document (including a GSM document), a non-specific reference implicitly refers to the latest version of that document *in the same Release as the present document*.

- [1] ITU-T Recommendation I.356 (03/2000): "B-ISDN ATM layer cell transfer performance".
- [2] ITU-T Recommendation I.363.2 (09/97): "B-ISDN ATM adaptation layer type 2 specification".
- [3] ITU-T Recommendation I.363.2 (11/2000): "B-ISDN ATM adaptation layer type 2 specification".
- [4] ITU-T Recommendation I.366.1 (06/98): "B-ISDN ATM adaptation layer type 2 specification".
- [5] ITU-T Recommendation Q.2630.1 (12/1999): "AAL type 2 signalling protocol (Capability set 1)".
- [6] ITU-T Recommendation Q.2630.2 (12/2000): "AAL type 2 signalling protocol (Capability set 2)".
- [7] ITU-T Technical Report TRQ.2400 (03/1999): "Signalling requirements for AAL type 2 link control capability set 1".
- [8] 3G TS 23.107: "QoS concept and architecture".
- [9] 3G TS 25.413: "UTRAN Iu interface RANAP signalling".
- [10] 3G TS 25.423: "UTRAN Iur interface RNSAP signalling".
- [11] 3G TS 25.433: "UTRAN Iub interface NBAP signalling".
- [12] 3G TR 25.954: "Transport bearer modification procedure on Iub, Iur, and Iu".

3 Definitions, symbols and abbreviations

3.1 Definitions

No specific definition is made in this document.

3.2 Symbols

No specific symbol is defined in this document.

3.3 Abbreviations

For the purposes of the present document, the following abbreviations apply:

AAL	ATM Adaptation Layer
AAL2	ATM Adaptation Layer type 2
ALCAP	Access Link Control Application Part
ATM	Asynchronous Transfer Mode
CDV	Cell delay variation
CFN	Connection Frame Number
CN	Core Network
CPS	Common Part Sublayer
CRNC	Controlling RNC
CS	Capability Set
CS	Circuit Switched
CTD	Cell transfer delay
DCH	Dedicated Channel
DRNC	Drift RNC
GPRS	General Packet Radio Service
GTP-U	GPRS Tunnelling Protocol User plane
IE	Information Element
MAC-d	Medium Access Control for DCH
MSC	Mobile Switching Center
NBAP	Node B Application Part
QoS	Quality of Service
RAB	Radio Access Bearer
RANAP	Radio Access Network Application Part
RNC	Radio Network Controller
RNSAP	Radio Network Subsystem Application Part
SAP	Service Access Point
SDU	Service Data Unit
SGSN	Serving GPRS Support Node
SRNC	Serving RNC
SSCS	Service Specific Convergence Sublayer
SSSAR	Service Specific Segmentation and Reassembly Sublayer
SW	Switch
TTI	Time Transmission Interval
UE	User Equipment
UMTS	Universal Mobile Telecommunication System
UTRAN	Universal Terrestrial Radio Access Network
VC	Virtual Connection

4 Issue to be improved

4.1 Priority capability in Release 99

Transmission resource inside the UTRAN should be optimised. Decreasing the ATM required bandwidth for the same net bit rate could allow an operator to decrease its transmission and operating cost.

In network configurations using AAL type 2 switches, no priority is handled at AAL type 2 or ATM level in Release 99, and all AAL type 2 channels shall be transported with the most stringent transfer delay (transfer delay of real time services). The required instantaneous bit rate on the Iub and Iur interfaces will be higher than in case AAL type 2 or ATM level priority is supported.

In network configurations which do not use AAL type 2 switches, and where the implementation of I.363.2^[2] or Q.2630.1^[5] provides the capability, priority may be handled without affecting the signalling messages and message sequences of NBAP^[11], RNSAP^[10], and RANAP^[9], or Q.2630.1^[5].

4.1.1 Prioritisation at AAL type 2 level

At a node, QoS at the AAL type 2 layer may be realized with possible proprietary implementation of I.363.2^[2], though there exists no standardized means to provide QoS at the AAL type 2 level in I.363.2^[2]. NBAP^[11], RNSAP^[10], and RANAP^[9] may give the requested QoS to the node. No indication of the requested QoS is given at an intermediate AAL type 2 switch.

4.1.1.1 I.363.2^[2]

The protocol stack for the user plane is, from the top, SSSAR of I.366.1^[4]/I.363.2^[2]/ATM layer/Physical layer. It is common for Iub/Iur Common Transport Channel and DCH data streams, and Iu CS domain data stream.

QoS is provided by the ATM layer and there exists no standardized means to provide QoS at the AAL type 2 layer in I.363.2^[2]^[3]. See the last sentence of section 6.1 of Revised I.363.2 (11/2000)^[3] which has a clear description on the study status on this point.

The multiplexing function in the Common Part Sublayer merges several streams of CPS-Packets onto a single ATM connection. The method of scheduling the different streams and the possible use of priorities is not specified. See section 10 of I.363.2^[2]^[3].

4.1.2 Prioritisation at ATM level

In network configurations which do not use AAL type 2 switches, and where the implementation of Q.2630.1^[5] provides the capability, priority at the ATM layer may be handled without affecting the signalling messages and message sequences of Q.2630.1^[5].

4.1.2.1 Q.2630.1^[5]

Q.2630.1^[5] is applied as ALCAP to establish/release an AAL type 2 connection over Iub, Iur, and Iu (CS domain) interfaces in Release 99. TRQ.2400^[7] does not require Q.2630.1^[5] a capability to select a succeeding AAL type 2 path according to the requested QoS for the AAL type 2 path. TRQ.2400^[7] is common for both the main body (superset) and ANNEX A "Support for non-switched scenario" (subset of the main body). Thus Q.2630.1^[5] has no explicit definition to treat the capability.

In ANNEX A, the routing function is located in the AAL type 2 served user where the definition of it is out of scope of Q.2630.1^[5]. This implies that the capability to select the succeeding AAL type 2 path according to the requested QoS for the AAL type 2 path may be provided by the AAL type 2 served user. ANNEX A is applicable in case of no AAL type 2 switch.

4.2 Required instantaneous bit rate

Figure 1 shows an example of possible Release 99 scheduling (with no QoS optimization at transmission). It has a

capability to spread out load over Iub and load in a cell.

Note that in this Figure 1:

- Blocks show downlink data frames dedicated to two DCHs,
- Shorter data frames are for real time (stringent real time) traffic, and longer ones are for non-real time (tolerant real time) traffic,
- Downlink data frames are scheduled by two MAC-d instances in a SRNC,
- CFN values of the two connections at a time are aligned to ease the explanation.

However, collision of the scheduling can occur in following cases and it results in possible delay or thicker Iub transmission. The cases are:

- Node B consists of multiple cells and Iub transmission is common for them,
- Down link data frames for drift branch of diversity handover scheduled by MAC-d s in other SRNC present in the same Iub transmission, or
- Multiple transport channels for one UE, etc..

By nature, the required instantaneous bit rate for Iub transmission is twice of Figure 2 with QoS optimization (Release 4). Figure 1 requires 4 blocks instantaneous bit rate though Figure 2 requires 2 blocks.

In a simple calculation, if one of the longer data frames in Figure 1 is, e.g., user bit rate 144kbit/s and its TTI is 80 ms, the size of the data frame is $144\text{kbit/s} \times 80\text{ms} = 1440 \text{ octets} = 32 \text{ CPS packets} = 33 \text{ ATM cells}$.

And if the allowed transmission time on the Iub interface is short (for example 5 ms), the required instantaneous bit rate on the Iub interface is $53 \text{ octets} \times 8 \text{ bits} \times 33 \text{ ATM cells} / 5 \text{ ms} = 2.8 \text{ Mbit/s}$.

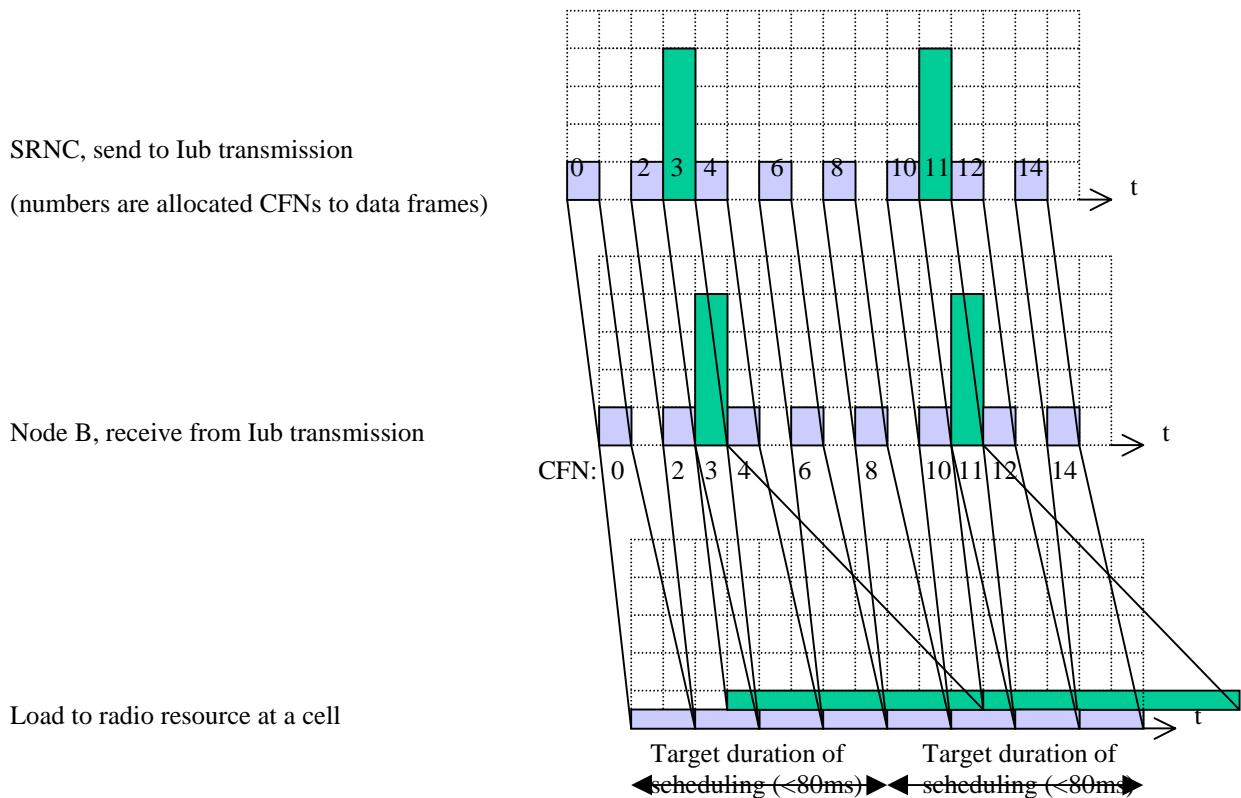

Figure 1: Example possible Release 99 scheduling at a cell with no QoS optimization at transmission

Figure 2 shows an example of possible scheduling with QoS optimization for AAL type 2 connections. The SRNC may assign a future CFN to the longer data frame (non-real time traffic) according to the expected propagation delay over the underlying VC(s) in order to be arrived on time at the destination Node B(s). Other assumptions for this Figure 2 are as same as in Note for Figure 1.

Even in case of collision of the scheduling, real time (stringent real time) traffics are given higher priorities, therefore possible delay of real time (stringent real time) traffics or thicker Iub transmission can be avoided.

If the allowed transmission time on the Iub interface for the longer data frame (e.g. 144kbit/s user bit rate) in Figure 2 is longer (for example 50 ms), the required instantaneous bit rate on the Iub interface for the longer data frame is $53 \text{ octets} * 8 \text{ bits} * 33 \text{ ATM cells} / 50 \text{ ms} = 0.28 \text{ Mbit/s}$.

In a simple calculation, if one of the shorter data frames in Figure 2 is, e.g., user bit rate 12.2kbit/s and its TTI is 20 ms, the size of the data frame is $12.2 \text{ kbit/s} * 20 \text{ ms} = 31 \text{ octets} = 1 \text{ CPS packets} = 1 \text{ ATM cells}$. And if the allowed transmission time on the Iub interface for the shorter data frame is short (for example 5 ms), the required instantaneous bit rate on the Iub interface for the shorter data frame is $53 \text{ octets} * 8 \text{ bits} * 1 \text{ ATM cells} / 5 \text{ ms} = 0.09 \text{ Mbit/s}$.

The total required instantaneous bit rate on the Iub interface is 0.37 Mbit/s

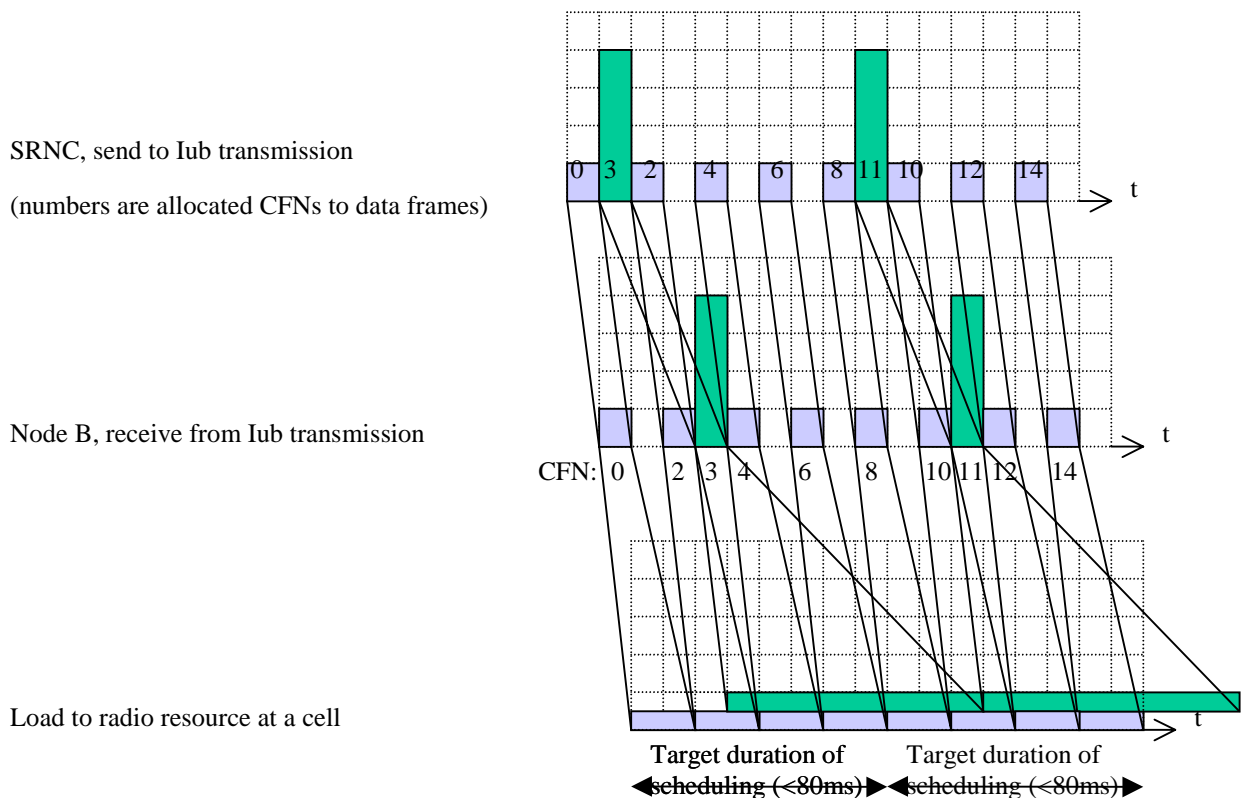

Figure 2: Example possible Release 4 scheduling at a cell with QoS optimization at transmission

5 UTRAN transport network configuration

This clause shows possible Iur interface transport network configurations, which should be considered in the solution for QoS optimization of AAL type 2 connections over the Iub and Iur interfaces. Iub transmission with intermediate ATM switch or AAL type 2 switch is not excluded.

5.1 Direct connection

Figure 4 shows a possible Iur interface transport network configuration with direct connections (solid lines) among RNCs.

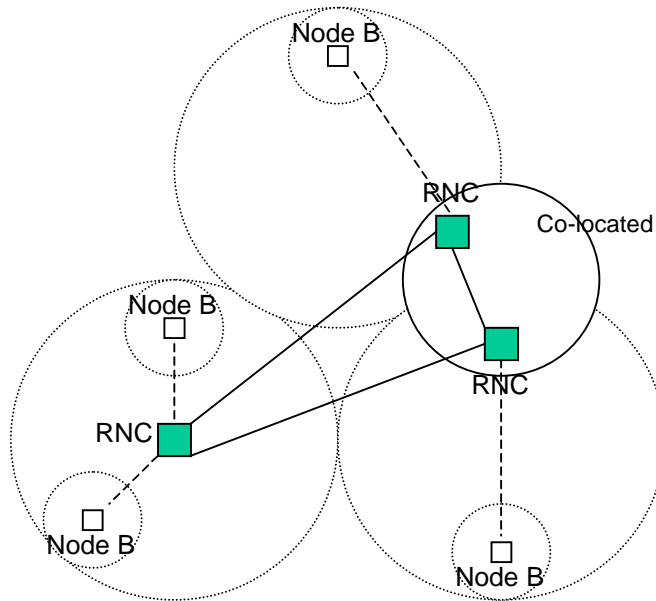

Figure 4: Direct connections

5.2 ATM switch

Figure 5 shows a possible Iur interface transport network configuration with ATM switch (solid lines) among RNCs. Terminating nodes of underlying VCs for Iur interfaces are RNCs, which are the same as in the Direct connection case.

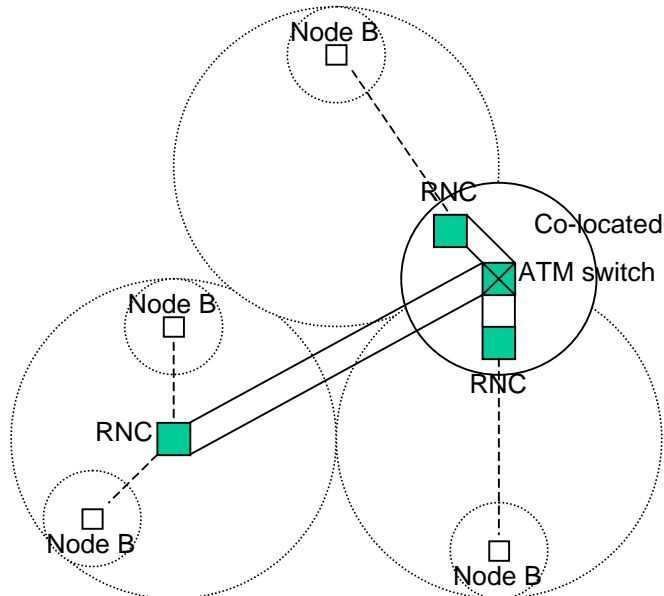

Figure 5: ATM switch

5.3 AAL type 2 switch

Figure 6 shows a possible Iur interface transport network configuration (can be common for Iu interface transport) with AAL type 2 switch (solid lines) among RNCs. Underlying VCs for the Iur interfaces are a star configuration from CN/AAL type 2 switch to RNCs.

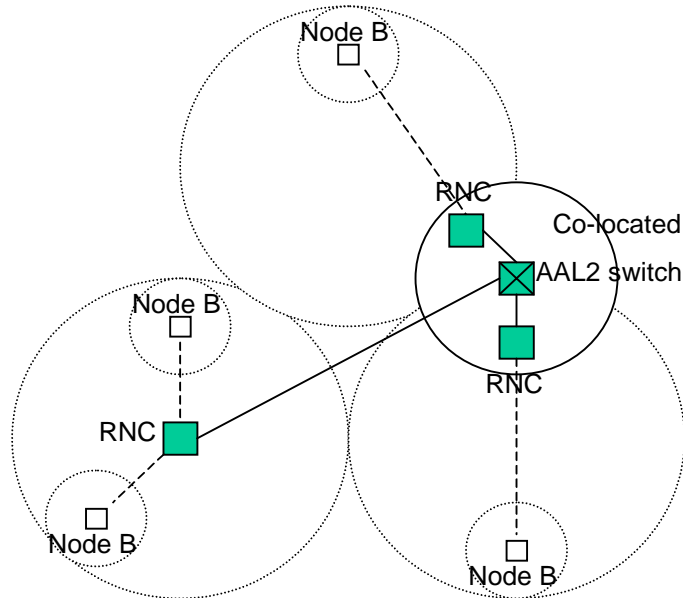

Figure 6: AAL type 2 switch

6 Solution for QoS optimization of AAL type 2 connection

This clause lists up possible solution to realize QoS optimization of AAL type 2 connections.

6.1 Priority capability in Q.2630.2^[6] (Q.aal2 CS2)

This subclause introduces “Path type” capability in Q.2630.2^[6] to realize QoS optimization for AAL type 2 connection which is in line with I.363.2^{[2][3]} that QoS is provided by the ATM layer. This solution can be applied also in the case of intermediate AAL type 2 switches.

6.1.1 Path type capability

Figure 7 shows the idea of Path type capability. The capability to select a succeeding AAL type 2 path or underlying VC according to the requested path type is deployed in AAL type 2 endpoints and AAL type 2 switching nodes. An AAL type 2 connection is established within a series of AAL type 2 paths align with the requested path type.

Absence of the new parameter “Path type” in the ESTABLISH.request primitive at an originating AAL type 2 endpoint or in the Establish Request message at an AAL type 2 switching node indicates that the network default stringent AAL type 2 path expected in Q.2630.1^[5] is requested. In case the new parameter “Path type” is present, it indicates the requested QoS for the AAL type 2 path. The path type parameter contains an ATM QoS code point. The range of the codepoint is 0 – 255. The code points 1, 2, and 5 indicate stringent, tolerant, and stringent bi-level respectively. The code points 0, 3, 4, and 6 - 127 are reserved for assignment by ITU-T. The code points 128 – 255 are reserved for network specific assignment.

The code point is just an indicator to select an AAL type 2 path and the exact QoS of the AAL type 2 path for the code point is implementation specific. However all the QoSs indicated by the code points have to be within the boundaries of stringent class, tolerant class, or stringent bi-level class as defined in I.356^[1].

Expected difference of QoS for the QoS optimization use is mainly CTD (Cell transfer delay) and CDV (Cell delay variation) within the boundary of stringent class as defined in I.356^[1]. The code points reserved for network specific assignment may be used to indicate different path types within the boundary of stringent class. Looser CTD and CDV must require thinner virtual bandwidth which may be applied for tolerant real time traffic. The expected difference of QoS for user traffic may be originated by UMTS QoS classes (conversational, streaming, interactive, and background) in 3G TS 23.107^[8]. But the number of AAL type 2 paths for the user traffic indicated by path types at a section may be converged from the four QoS classes. To avoid inefficiency due to bandwidth fragmentation, the number of AAL type 2 paths should be minimised. E.g. the number of AAL type 2 paths for the user traffic indicated by path types at a section may be two; One is for Conversational, the other is for Streaming, Interactive, and Background.

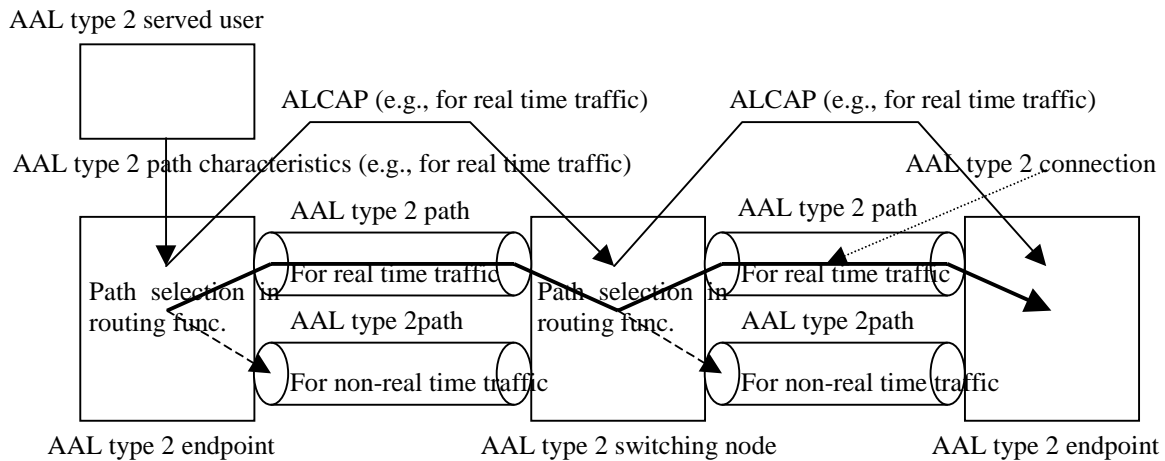

Figure 7: AAL type 2 path selection according to requested AAL type 2 path type

6.1.2 Application of Q.2630.2^[6] onto UTRAN transport network

Figures 8 and 9 show how QoS related IE will be informed to related nodes in each transport network configuration. RAB parameter IE of RANAP^[10] is interpreted to path type IE of ALCAP^[6] at SRNC. DRNC may re-determine the path type based on the related RNSAP information.

6.1.2.1 Direct and ATM switch cases

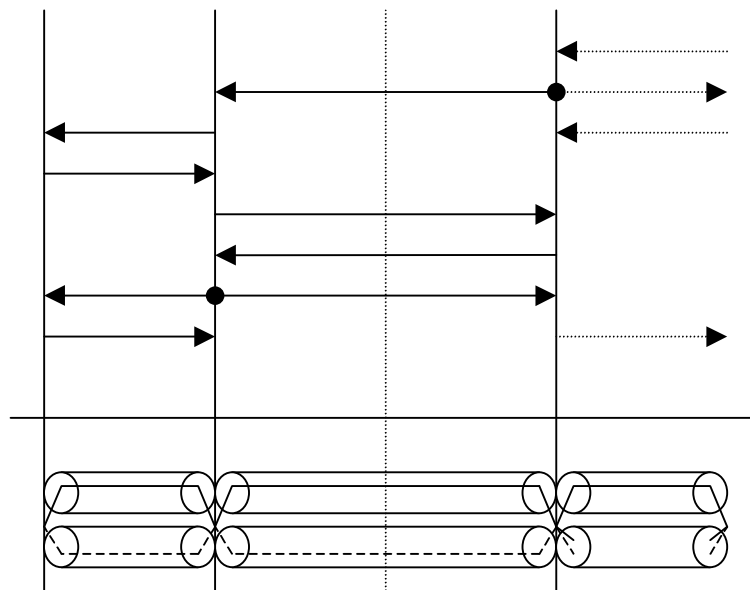

Figure 8: Direct and ATM switch cases

6.1.2.2 AAL type 2 switch case

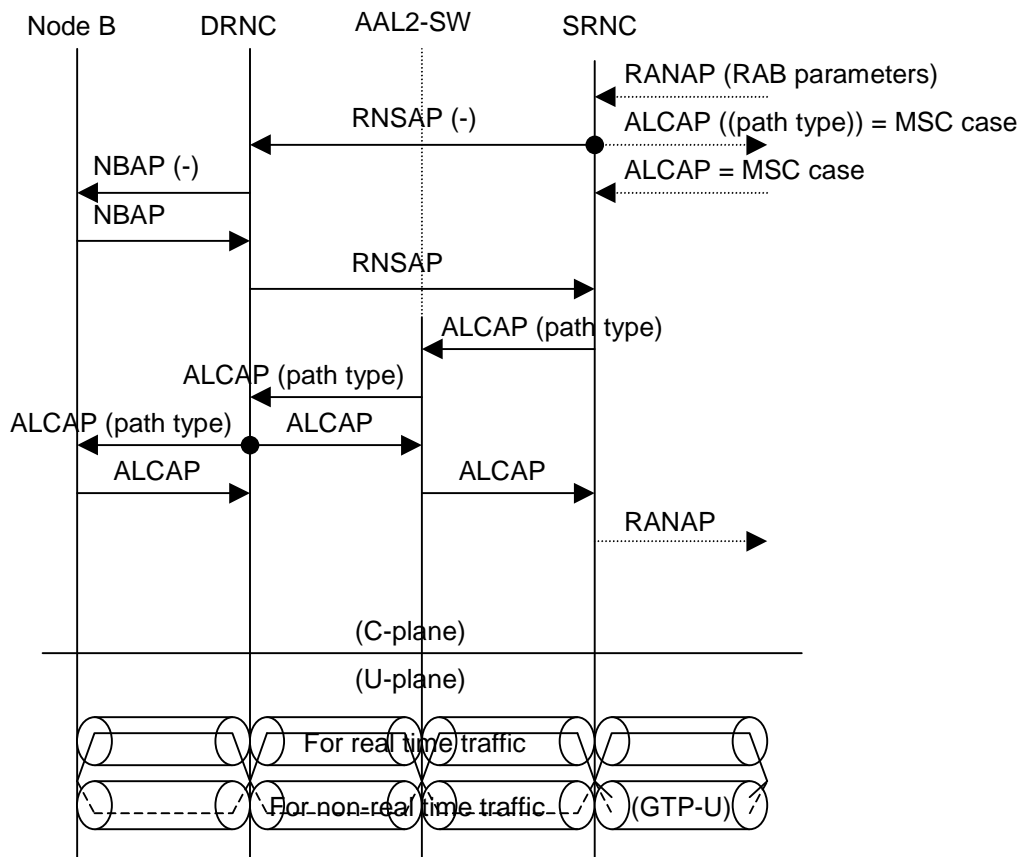

Figure 9: AAL type 2 switch case

6.2 Other solution

There is no other existing or emerging standardized solution for QoS optimization of AAL type 2 connection at AAL2 level or ATM level which can be applied to both cases with and without intermediate AAL type 2 switch in Release 4 time frame.

7 Backward compatibility

7.1 Backward compatibility between Q.2630.1^[5] and Q.2630.2^[6]

Q.2630.1^[5] and Q.2630.2^[6] have their own compatibility mechanism since Q.2630.1^[5]. To utilize the mechanism, see section 8.2.1.4 “Interworking with AAL type 2 nodes conforming only to ITU-T Recommendation Q.2630.1” and Annex B “Coding of the compatibility information” of Q.2630.2^[6].

Q.2630.2^[6] specifies optional capabilities/features to enhance Q.2630.1^[5]. And Q.2630.2^[6] includes Q.2630.1^[5]. This means if a new capability in Q.2630.2^[6] is not utilized, related implementation with the capability is not affected even Q.2630.2^[6] is referred.

8 Change request

This clause lists up place where Change request needs to be given to enhance Release 99 specification to Release 4 specification for the work task.

8.1 Q.2630.1^[5] to Q.2630.2^[6]

Table 1 shows place where Change request is needed in order to refer to Q.2630.2^[6].

Table 1: Place where Change request is given (Q.2630.2^[6])

3G TS/TR	Title	Clause/Subclause	Number of point(s)	Remarks
3G TS 25.420	UTRAN lur interface: general aspects and principles	8 Figure 4	Subtotal: 1	
3G TS 25.424	UTRAN lur interface: data transport & transport signalling for common transport channel data streams	2 [4], 6.2	Subtotal: 2	
3G TS 25.426	UTRAN lur and lub interfaces: data transport & transport signalling for DCH data streams	2 [5], 6.1, 7.2 Figure 2, 8.2 Figure 3	Subtotal: 5	
3G TS 25.430	UTRAN lub interface: general aspects and principles	7 Figure 7	Subtotal: 1	
3G TS 25.434	UTRAN lub interface: data transport & transport signalling for common transport channel data streams	2 [3], 6.2, 7.2, 7.2 Figure 2	Subtotal: 5	
3G TR 25.931	UTRAN functions, examples on signalling procedures	Contents - 4.6.1, 4.6, 4.6.1, 4.6.1 Figure 2, 7.8.1 text step 10	Subtotal: 6	

8.2 Path Type parameter

Table 2 shows place where Change request is needed in order to indicate the possible utilisation of Path Type parameter in Establish Request message for prioritisation at ATM level.

Table 2: Place where Change request is given (Path Type parameter)

3G TS/TR	Title	Clause/Subclause	Number of point(s)	Remarks
3G TS 25.424	UTRAN lur interface: data transport & transport signalling for common transport channel data streams	6.2	Subtotal: 1	
3G TS 25.426	UTRAN lur and lub interfaces: data transport & transport	6.1	Subtotal: 1	

	signalling for DCH data streams			
3G TS 25.434	UTRAN lub interface: data transport & transport signalling for common transport channel data streams	6.2	Subtotal: 1	

8.3 I.363.2 (09/97)^[2] to Revised I.363.2 (11/2000)^[3]

Table 3 shows place where Change request is needed in order to refer to Revised I.363.2^[3]. Revised I.363.2^[3] has new Annex C to facilitate the understanding of the switching aspects of AAL type 2 connections and is kinder reference for readers.

Table 3: Place where Change request is given (Revised I.363.2^[3])

3G TS/TR	Title	Clause/Subclause	Number of point	Remarks
3G TS 25.414	UTRAN lu interface: data transport & transport signalling	2 [2]	Subtotal: 1	
3G TS 25.415	UTRAN lu interface: user plane protocols	2 [7]	Subtotal: 1	
3G TS 25.424	UTRAN lur interface: data transport & transport signalling for common transport channel data streams	2 [2]	Subtotal: 1	
3G TS 25.425	UTRAN lur interface: user plane protocols for common transport channel data streams	2 [2]	Subtotal: 1	
3G TS 25.426	UTRAN lur and lub interfaces: data transport & transport signalling for DCH data streams	2 [3]	Subtotal: 1	
3G TS 25.434	UTRAN lub interface: data transport & transport signalling for common transport channel data streams	2 [1]	Subtotal: 1	

8.4 Handling of other new capabilities in Q.2630.2^[6]

One of other new capabilities in Q.2630.2^[6] "Modification of AAL type 2 connection resources (link characteristics)" may be utilized for UTRAN. However it is out of scope of the present document. See TR 25.954^[12] "Transport bearer modification procedure on Iub, Iur, and Iu" for the capability.

Annex A: Change history

Change history							
Date	TSG #	TSG Doc.	CR	Rev	Subject/Comment	Old	New
03/2001	11	RP-010147	-	-	Approved at TSG RAN #11 and placed under Change Control	2.0.0	4.0.0

History

Document history		
V4.0.0	March 2001	Publication