



**Digital cellular telecommunications system (Phase 2+);
Universal Mobile Telecommunications System (UMTS);
LTE;
Services alignment and migration
(3GPP TR 22.983 version 12.0.0 Release 12)**



Reference

RTR/TSGS-0122983vc00

Keywords

GSM, LTE, UMTS

ETSI

650 Route des Lucioles
F-06921 Sophia Antipolis Cedex - FRANCE

Tel.: +33 4 92 94 42 00 Fax: +33 4 93 65 47 16

Siret N° 348 623 562 00017 - NAF 742 C
Association à but non lucratif enregistrée à la
Sous-Préfecture de Grasse (06) N° 7803/88

Important notice

The present document can be downloaded from:

<http://www.etsi.org>

The present document may be made available in electronic versions and/or in print. The content of any electronic and/or print versions of the present document shall not be modified without the prior written authorization of ETSI. In case of any existing or perceived difference in contents between such versions and/or in print, the only prevailing document is the print of the Portable Document Format (PDF) version kept on a specific network drive within ETSI Secretariat.

Users of the present document should be aware that the document may be subject to revision or change of status. Information on the current status of this and other ETSI documents is available at

<http://portal.etsi.org/tb/status/status.asp>

If you find errors in the present document, please send your comment to one of the following services:

http://portal.etsi.org/chaicor/ETSI_support.asp

Copyright Notification

No part may be reproduced or utilized in any form or by any means, electronic or mechanical, including photocopying and microfilm except as authorized by written permission of ETSI.

The content of the PDF version shall not be modified without the written authorization of ETSI.

The copyright and the foregoing restriction extend to reproduction in all media.

© European Telecommunications Standards Institute 2014.

All rights reserved.

DECT™, **PLUGTESTS™**, **UMTS™** and the ETSI logo are Trade Marks of ETSI registered for the benefit of its Members. **3GPP™** and **LTE™** are Trade Marks of ETSI registered for the benefit of its Members and of the 3GPP Organizational Partners.

GSM® and the GSM logo are Trade Marks registered and owned by the GSM Association.

Intellectual Property Rights

IPRs essential or potentially essential to the present document may have been declared to ETSI. The information pertaining to these essential IPRs, if any, is publicly available for **ETSI members and non-members**, and can be found in ETSI SR 000 314: *"Intellectual Property Rights (IPRs); Essential, or potentially Essential, IPRs notified to ETSI in respect of ETSI standards"*, which is available from the ETSI Secretariat. Latest updates are available on the ETSI Web server (<http://ipr.etsi.org>).

Pursuant to the ETSI IPR Policy, no investigation, including IPR searches, has been carried out by ETSI. No guarantee can be given as to the existence of other IPRs not referenced in ETSI SR 000 314 (or the updates on the ETSI Web server) which are, or may be, or may become, essential to the present document.

Foreword

This Technical Report (TR) has been produced by ETSI 3rd Generation Partnership Project (3GPP).

The present document may refer to technical specifications or reports using their 3GPP identities, UMTS identities or GSM identities. These should be interpreted as being references to the corresponding ETSI deliverables.

The cross reference between GSM, UMTS, 3GPP and ETSI identities can be found under <http://webapp.etsi.org/key/queryform.asp>.

Modal verbs terminology

In the present document "**shall**", "**shall not**", "**should**", "**should not**", "**may**", "**may not**", "**need**", "**need not**", "**will**", "**will not**", "**can**" and "**cannot**" are to be interpreted as described in clause 3.2 of the [ETSI Drafting Rules](#) (Verbal forms for the expression of provisions).

"**must**" and "**must not**" are **NOT** allowed in ETSI deliverables except when used in direct citation.

Contents

Intellectual Property Rights	2
Foreword.....	2
Modal verbs terminology.....	2
Foreword.....	4
1 Scope	5
2 References	5
3 Definitions and abbreviations.....	5
3.1 Definitions	5
3.2 Abbreviations	5
4 Definition of Service Sets in different domains	6
4.1 CS/PS (non-IMS) domain	6
4.1.1 CS Services (teleservices & bearer services).....	6
4.1.2 PS main services	6
4.1.3 Supplementary services	6
4.1.4 Other services	7
4.2 IMS domain.....	7
4.2.1 Main services	7
4.2.2 Supplementary services	7
4.3 TS & BS relationship between domains.....	8
4.4 SS and other services relationship between domains	8
5 Service alignment between domains	10
5.1 Connection scenarios.....	10
5.2 Network configurations	10
5.3 Service experience.....	11
6 Use cases	11
6.1 Use case 1, MSC server control of all accesses.....	11
6.2 Use case 2, migrating to IMS	11
6.3 Use case 3, after migration to IMS	11
6.4 Use case 4, inter-working between IMS & CS based networks	12
6.5 Use case 5, roaming.....	12
7 Migration scenarios	12
7.1 Background	12
7.2 Abrupt switch over to centralized IMS call and service control.....	12
7.3 Smooth phase out of CS	13
8 Conclusions	13
Annex A: Change history	15
History	16

Foreword

This Technical Report has been produced by the 3rd Generation Partnership Project (3GPP).

The contents of the present document are subject to continuing work within the TSG and may change following formal TSG approval. Should the TSG modify the contents of the present document, it will be re-released by the TSG with an identifying change of release date and an increase in version number as follows:

Version x.y.z

where:

- x the first digit:
 - 1 presented to TSG for information;
 - 2 presented to TSG for approval;
 - 3 or greater indicates TSG approved document under change control.
- y the second digit is incremented for all changes of substance, i.e. technical enhancements, corrections, updates, etc.
- z the third digit is incremented when editorial only changes have been incorporated in the document.

1 Scope

This document studies how services to the end user should be delivered and managed regardless of how the user accesses the services (e.g. using CS or IMS) and to ensure a consistent user experience.

The services in scope include but are not restricted to:

- Conversational voice and video services
- Messaging services
- Supplementary Services as applied to the above.

For each of the above types, the service features that should be supported when accessing the service via CS or IMS using any appropriate access type are described. Also, how each service will behave when transferring between domains is described.

The work will also consider how to support existing ("traditional") services while allowing new, innovative services to be provided to the end user using the enhanced capabilities of the IMS. It will cover possible migration paths from where services are provided on both CS and IMS to IMS Call and Service Control. Also, this work will consider roaming and call handling, interaction with legacy terminals, and the provision of user state and location for services accessed via CS or IMS and for services transferred between them.

2 References

The following documents contain provisions which, through reference in this text, constitute provisions of the present document.

- References are either specific (identified by date of publication, edition number, version number, etc.) or non-specific.
- For a specific reference, subsequent revisions do not apply.
- For a non-specific reference, the latest version applies. In the case of a reference to a 3GPP document (including a GSM document), a non-specific reference implicitly refers to the latest version of that document *in the same Release as the present document*.

[1] 3GPP TR 21.905: "Vocabulary for 3GPP Specifications".

3 Definitions and abbreviations

3.1 Definitions

For the purposes of the present document, the terms and definitions given in TR 21.905 [1] and the following apply. A term defined in the present document takes precedence over the definition of the same term, if any, in TR 21.905 [1].

3.2 Abbreviations

For the purposes of the present document, the abbreviations given in TR 21.905 [1] and the following apply. An abbreviation defined in the present document takes precedence over the definition of the same abbreviation, if any, in TR 21.905 [1].

4 Definition of Service Sets in different domains

4.1 CS/PS (non-IMS) domain

4.1.1 CS Services (teleservices & bearer services)

Telephony

Emergency calls

Short Message Service (SMS MO/SMS MT)

Alternate speech and facsimile (Group 3)

Automatic facsimile (Group 3)

Asynchronous Data – 2G

Synchronous Data – 2G

High Speed Circuit Switched Data (HSCSD) – 2G

Circuit Switched Data - 3G

4.1.2 PS main services

GPRS (including EDGE) – 2G

Packet Data (including HSPA) – 3G

4.1.3 Supplementary services

Calling Line Identification Presentation (CLIP)

Calling Line Identification Restriction (CLIR)

Connected Line Identification Presentation (CoLP)

Connected Line Identification Restriction (CoLR)

Calling Name Presentation (CNAP)

Call Forwarding Unconditional (CFU)

Call Forwarding on mobile subscriber busy (CFB)

Call Forwarding on no reply (CFNRy)

Call Forwarding on mobile subscriber not reachable (CFNRc)

Call Waiting (CW)

Call Hold (HOLDcall)

Multi-party (MPTY)

Multi-call (MC)

Closed User Group (CUG)

Completion of Calls to Busy Subscribers (CCBS)

Call Deflection (CD)

Explicit Call Transfer (ECT)

Barring of all outgoing calls (BAOC)

Barring of all outgoing international calls (BOIC)

Barring of all outgoing international calls except home country (BOIC ex HC)

Barring of all incoming calls (BAIC)

Barring of all incoming calls when roaming outside HPLMN (BAIC-roam)

Operator Determined Barring (ODB)

User to User signalling (UUS)

Unstructured Supplementary Service Data (USSD MO/USSD MT)

Advice of Charge (AoC)

Support of Private Numbering Plan (SPNP)

4.1.4 Other services

Customised Applications for Mobile Network Enhanced Logic (CAMEL). This enables support for:

- Value Added Services in HPLMN and VPLMN (available in most networks)
- Optimised routing of mobile originated voice communications when roaming

Enhanced Multi-Level Precedence & Pre-emption (eMLPP)

Support of Localised Service Area (SoLSA)

4.2 IMS domain

4.2.1 Main services

Multimedia Telephony Service

4.2.2 Supplementary services

Note that the Supplementary Services listed below apply only to the Multimedia Telephony Service

Originating Identification Presentation (OIP)

Originating Identification Restriction (OIR)

Terminating Identification Presentation (TIP)

Terminating Identification Restriction (TIR)

Malicious Call Identification (MCID)

Anonymous Call Rejection (ACR)

Communication Waiting (CW)

Communication Diversion (CDIV)

Communication Hold (HOLDcomm)

Communication Barring (CB)

Completion of Communication to Busy Subscriber (CCBS)

Message Waiting Indication (MWI)

Conference (CONF)

Explicit Communication Transfer (ECommT)

Closed User Group (CUG)

Reverse Charging

Advice of Charge (AOC)

4.3 TS & BS relationship between domains

The mapping between the teleservices and bearer services in the IMS and non-IMS domains is defined below. Generally, the services used in one domain should still work if the user moves to another domain, however, the capabilities of the domain will dictate how the service performs. For example, the user will experience a much reduced data rate in moving from 3G HSPA to GPRS. This may make it impossible to continue the service. Some services defined for 2G/CSD have no equivalent in IMS (e.g some of the data services). It is not possible, therefore to define behaviour for these services.

The UE state (e.g. free, busy, not available etc) should be handled consistently to ensure that incoming and outgoing communications are handled appropriately. For example, the the UE is on a voice call in the non-IMS domain and an incoming communication arrives in the IMS domain, the appropriate action can be taken, e.g signal 'Communication Waiting' or divert on busy to voicemail.

Non-IMS Domain Service	Equivalent IMS Domain Service	Service Behaviour Required
Telephony	Multimedia Telephony Service	When moving between IMS to non-IMS, voice service at least should be maintained. UE state should be handled consistently. For example, if a user is on 2G and is busy on a voice call, any voice communication incoming from IMS should encounter a busy condition. Other multimedia communications could, however, be delivered to the UE if possible.
Emergency Calls	Multimedia Telephony Service	Emergency voice calls should be maintained when transferring between domains
SMS	SMS	SMSs can be sent transparently through IMS so this service should work consistently across domains
Facsimile services	Not defined	Not defined
Asynchronous Data	No equivalent	Not defined
Synchronous Data	No equivalent	Not defined
HSCSD	No equivalent	Not defined
3G CSD	No equivalent	Not defined
Packet data connection	No equivalent	Not defined
No equivalent	Data session	Not defined

4.4 SS and other services relationship between domains

The mapping between the Supplementary Services in the IMS and non-IMS domains is defined below. Generally, the Supplementary Services should be consistent as far as possible across the domains. As a default, settings used (e.g. Call Forwarding numbers) should be the same in both domains. The settings should be sent only once from the UE, the modification of settings in one domain should update the settings in the other domain automatically. However, it should also be possible to maintain separate settings if required in the different domains. For example, it should be possible to set Communication Diversion destinations for the separate media parts of the Multimedia Telephony Service including the voice part and have a different Call Forwarding number for voice when in the non-IMS domain..

Not all Supplementary Services have equivalents in the other domain, however. In these cases, some are not domain dependent and for others the appropriate service behaviour cannot be defined.

Also, there are some non-IMS services that have no equivalent in IMS and vice-versa or are not domain dependent, these are shown at the end of the table below.

Non-IMS Domain Service	Equivalent IMS Domain Service	Service Behaviour Required
CLIP/CLIR	OIP/OIR	Consistency of presentation
CoLP/CoLR	TIP/TIR	Consistency of presentation
CNAP	OIP/OIR	Consistency of presentation
No equivalent	MCID	Not defined
No equivalent	ACR	Not defined
Call Forwarding	CDIV	Call forwarding/CDIV should work consistency no matter which domain the user is in. The settings (e.g.. forwarding numbers) should remain the same across domains for all the parts of the service for which there is an equivalent. However, it should be possible to set different forwarding destinations in the different domains for non-IMS voice and the voice part of Multimedia Telephony Service
Call Waiting	Communication Waiting	The busy state of the user should be available to both domains so that this can be applied no matter from which domain an incoming call/communication originates
Call Hold	Communication HOLD	Any calls held in one domain should remain held on moving to a different domain. It should be possible to un-hold a call that was put on hold in another domain.
Multiparty	CONF	Any conference (multiparty) calls set up in one domain should remain in force if any user moves to another domain.
Multi-call	No equivalent	Not defined
Closed User Group	Closed User Group	Consistency required across domains
CCBS	CCBS	Should work consistently across domains
Call Deflection	Defined in CDIV	Should work consistently across domains
Explicit Call Transfer	ECommT	Should work consistently across domains. The UE state (i.e. if busy or not) should be available in both domains to ensure that this can be applied consistently.
Call Barring	Communication Barring	Call/ Communication Barring should work consistency no matter which domain the user is in. The settings (i.e. barred numbers) should remain the same across domains.
ODB	Included in Communication Barring	As above
No equivalent	Message Waiting Indication	Not defined
No equivalent	Reverse Charging	Not defined
UUS	No equivalent	Not defined
USSD	No equivalent	Not defined
AoC	AoC	Consistent support across domains. If the user moves from one domain to the other during the communication, the AoC should indicate the correct charge for the total duration of the communication.
SPNP	No equivalent	Not defined
eMLPP	No equivalent	Not defined
Other Services		
CAMEL	CAMEL	The services offered should be consistent.

5 Service alignment between domains

5.1 Connection scenarios

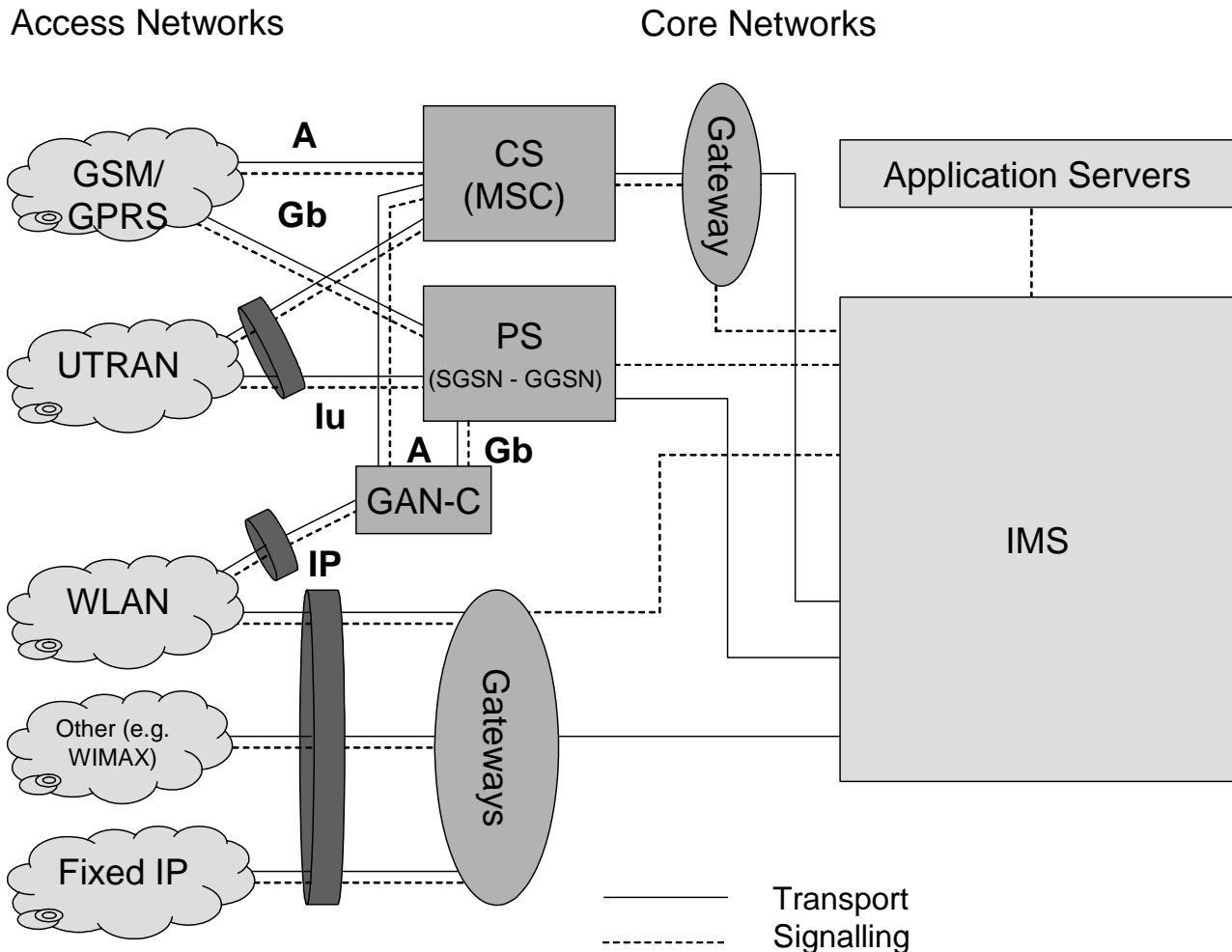

The possible connection scenarios are:

- 2G (GSM/GPRS) radio access network connected to Circuit Switched and Packet Switched core;
- 3G (UMTS) radio access network connected to Circuit Switched and Packet Switched core;
- 2G (GSM/GPRS) radio access network connected to IMS via the PS core;
- 3G (UMTS) radio access network connected to IMS via the PS core;
- WLAN radio access network connected to Circuit Switched and Packet Switched core (GAN);
- WLAN radio access network connected to IMS via the PS core.

Each of the above connection scenarios will have its own service characteristics. There is a range of access speeds from the radio access networks and a range of capabilities from the core networks and these will determine how a particular service can be delivered and, therefore, the customer experience.

5.2 Network configurations

For many operators' networks, there will be a range of connection scenarios in use as described above. This will arise as the core networks and access networks are upgraded. The options for how networks are upgraded are described in

section 6, below. What is clear is that most operators will have networks in which there are mixed capabilities for a considerable period and that the way services are managed needs to be considered. The key points to consider concerning customer service experience are described below.

5.3 Service experience

The user's service experience needs to be consistent depending on the connection scenario used.

Specifically, the following is required:

- The use of Supplementary Services should be applied consistently across domains and, as a default, the setting of SS parameters in one domain should be reflected in the other domain. For example, any Call Forwarding and Call Barring numbers set by the user should be retained and used whichever domain is used.
- It should, however, be possible to set different parameters in different domains if required. For example, capability to have different settings for Supplementary Services in IMS for enhanced services such as Multimedia Telephony Service should be possible.
- The smooth transition of services as the user moves from one connection scenario to another. If the user moves from a high capability scenario to a low capability scenario (e.g. from 3G/IMS to 2G/Circuit Switched) the service should be degraded gracefully. An example is the degradation of Multimedia Telephony to a voice only call. Subsequently, if the user moves back to a high capability scenario, the added features should become available again.

6 Use cases

6.1 Use case 1, MSC server control of all accesses

This use case describes the situation where an operator has introduced packet access and support for the services and service control on the MSC Server.

Initially users have voice service over CS on GSM/UMTS. Service and control for this is provided by the MSC. Voice service is transferred to VoIP on UMTS and WLAN. Service and control for VoIP is provided by MSC Server.

The user should be unaware of the change. For example, there should be no need for the user to change any settings (e.g. for supplementary services), and the services delivered should be as good as or better than before.

6.2 Use case 2, migrating to IMS

This use case describes the situation where an operator is undertaking a migration and has different configurations in the network in different regions.

Users on this operator use newer networks in part of the country and fallback to older networks elsewhere. For example, in the cities there is WiMAX, HSPA, UMTS and GSM/GPRS controlled by IMS; in urban areas there is HSPA, UMTS and GSM/GPRS controlled by MSC Servers and in rural areas there is just GSM/GPRS controlled by MSCs.

The user should experience a minimum service level when on the legacy part of the network and should generally be unaware that he/she is using the more advanced parts of the network except for the availability of new and improved services where provided. Additionally, there should be no need for the user to change any settings (e.g. for supplementary services) when moving from one part of the network to another.

6.3 Use case 3, after migration to IMS

This use case describes the situation where an operator has migrated all services and service control onto IMS from the traditional GSM network

Initially, users have voice service over CS, text messaging (SMS) over GSM and IM/Presence service over GSM/GPRS. Voice and SMS service and control are provided over MSCs/CAMEL; IM/Presence service and control is

provided over dedicated platform in the core network. All of these services have been migrated to IP based technology. All services are now provided and controlled by IMS.

The user should be unaware of the migration except for the availability of new and improved services. For example, there should be no need for the user to change any settings (e.g. for supplementary services), and the services delivered should be as good as or better than before.

6.4 Use case 4, inter-working between IMS & CS based networks

This use case describes the situation where users in a network that has completely migrated to IMS service and service control are communicating with users on legacy (CS based) networks.

Users on their Home PLMN have VoIP voice service provided and controlled by IMS. They need to be able to connect with other users on other networks who have voice service over CS that is provided and controlled by MSCs/CAMEL.

The user should be unaware that he/she is communicating with a user on a network with a different configuration. All supplementary services should continue to work correctly and as expected.

6.5 Use case 5, roaming

This use case describes the situation where a user from a network that has completely migrated to IMS service and service control roams on a legacy (CS based) network.

Users on their Home PLMN have VoIP voice service provided and controlled by IMS. A user roams onto a VPLMN that has voice services provided and controlled by MSCs/CAMEL. The VPLMN does not support PS access of sufficient quality for VoIP.

The user should be unaware that he/she is roaming on a legacy network except that some advanced services may not be available. There should be no difference in how the voice service is used including the use of supplementary services.

From the operator perspective, calls to and from the user should be handled in the most cost-effective manner. For example, outgoing calls from that user in the VPLMN should be handled locally with efficient routing of connections to and from the Home PLMN.

7 Migration scenarios

7.1 Background

Currently only one service is defined for the IMS, which is similar to an existing CS service, i.e. the Multimedia Telephony Service. Although it can be expected that also other services will be defined there will always be a set of services and features which is not available in the IMS or which has slightly different behaviour, despite a possible alignment.

For existing customers consistent service behaviour is very important. Adding new services and features is possible but it is nearly impossible to change or delete others (e.g. fax).

Additionally more and more different access systems are integrated (such as WiFi, WiMax, LTE etc.) and subscribers want to use their services regardless of the access, even regardless if the move from one access to the other (cp. VCC).

With these basic conditions several migration scenarios are possible.

7.2 Abrupt switch over to centralized IMS call and service control

In this scenario all subscribers are switched over to centralized IMS call and service control at a certain point in time. This would require that

- most services are available in IMS
- use of legacy services which are not available in IMS is very low (thus it may be acceptable to switch them off)
- radio coverage for broadband packet access is the same as that for circuit switched services.

It may be doubted if the last bullet point can be fulfilled in the near future in every network - HPLMN and VPLMNs. So instead it should be investigated how IMS can be used to control CS calls. This will be done in the ICS work item, TR 22.892 and TR 23.892.

Advantages of this migration path are:

- short time period in which both CS service control and IMS must be operated and maintained
- full support of service continuity over CS and PS is possible after switch over

Disadvantages are:

- need for re-implementation of existing services
- possible late switch over as some IMS unsupported services may still be required
- need for service alignment between CS and IMS before the switch over
- may result in early write-off of existing core-network assets

7.3 Smooth phase out of CS

In this migration scenario CS call control and IMS exist side by side for longer time. CS services are controlled in the CS domain, at the beginning only new services are offered via the IMS. This would mean that there is no immediate re-implementation of legacy services in the IMS needed, but also that these legacy services would not be available from a PS access system.

Therefore it should be investigated how CS call control can be offered via PS access systems.

Later on, when the coverage of PS access systems is sufficiently high, the most important services are available on the IMS and most people use the new IMS based services the CS system can be switched off.

Advantages of this migration path are

- no need for immediate re-implementation of legacy services in the IMS
- full support of service continuity over CS and PS is possible
- maximises the use of existing core network assets

Disadvantages are

- CS service control must operated and maintained for long time

8 Conclusions

With the various types of access and core networks that can be used, it is important that a consistent and predictable service is offered to the end user. This applies to the Tele-Services and Bearer Services and their IMS equivalents as well as the Supplementary Service set.

For the various voice, video and data services, it is important that the user experience is as consistent as possible across the different domains and that as the user moves from one domain to another the service is maintained as far as possible within the capabilities of the domain. This also applies to the various Supplementary Services that are applicable. It is important, therefore, that the new capabilities offered by enhanced networks are made available to the end user while at the same time ensuring that the service offered is degraded gracefully if the user moves to a less capable domain.

This also means that it is highly desirable to have some consistency in how the different types of mobile device interact with the network. This is to ensure that services such as Call/Communication Waiting, Call Forwarding/Communication Diversion and Call/Communication Barring all work correctly. The cases that need to be considered are where the user moves from one domain (i.e. a particular access network and a particular core network) to another and where the operator enhances the network by changing out old technology for new.

Consideration needs to be given to the user experience when roaming also to ensure that it is possible to deliver the appropriate service level consistent with the capabilities of the serving and home networks.

Some of the requirements identified in this TR will be met by the ICS (IMS Centralised Services) work and work on VCC. Some may need changes to existing Stage 1 specifications. The intention is to ensure that there is a consistency of data across the domains for supplementary services and that service control allows the transfer of services across domains whilst maintaining the highest level of service possible consistent with the capabilities of the domain.

Annex A: Change history

Change history											
TSG SA#	SA Doc.	SA1 Doc	Spec	CR	Rev	Rel	Cat	Subject/Comment	Old	New	Work Item
2008-03	SA#39	SP-080164						Raised to v.8.0.0 by MCC following SA#39 approval	2.0.0	8.0.0	
2009-12	SP-46							Updated to Rel-9 by MCC	8.0.0	9.0.0	
2011-03	-	-	-	-	-	-	-	Update to Rel-10 version (MCC)	9.0.0	10.0.0	
2012-09	-	-	-	-	-	-	-	Updated to Rel-11 by MCC	10.0.0	11.0.0	
2014-10								Updated to Rel-12 by MCC	11.0.0	12.0.0	

History

Document history		
V12.0.0	October 2014	Publication