



EUROPEAN
TELECOMMUNICATION
STANDARD

ETS 300 814

March 1998

Source: EBU/CENELEC/ETSI JTC

Reference: DE/JTC-DVB-29

ICS: 33.020

Key words: DVB, broadcasting, digital, video, TV, SDH



**Digital Video Broadcasting (DVB);
DVB interfaces to
Synchronous Digital Hierarchy (SDH) networks**

ETSI

European Telecommunications Standards Institute

ETSI Secretariat

Postal address: F-06921 Sophia Antipolis CEDEX - FRANCE

Office address: 650 Route des Lucioles - Sophia Antipolis - Valbonne - FRANCE

Internet: secretariat@etsi.fr - <http://www.etsi.fr> - <http://www.etsi.org>

Tel.: +33 4 92 94 42 00 - Fax: +33 4 93 65 47 16

Copyright Notification: No part may be reproduced except as authorized by written permission. The copyright and the foregoing restriction extend to reproduction in all media.

© European Telecommunications Standards Institute 1998.

© European Broadcasting Union 1998.

All rights reserved.

Contents

Foreword	5
1 Scope	7
2 References	7
2.1 ETSI and CENELEC publications	7
2.2 ITU publications	8
3 Definitions and abbreviations	8
3.1 Definitions	8
3.2 Abbreviations	9
4 Baseline specification	10
4.1 MPEG Physical Interface (MPI)	12
4.2 MPEG/ATM Adaptation (MAA)	16
4.3 Virtual Path Entity (VPE)	19
4.4 Virtual Path Multiplexing Entity (VPME)	20
4.5 Sm Trail Termination (Sm_TT)	22
4.5.1 S3 Trail Termination (S3_TT)	23
4.5.2 S2 Trail Termination (S2_TT)	25
4.5.3 S12 Trail Termination (S12_TT)	28
4.5.4 S11 Trail Termination (S11_TT)	31
4.6 Higher Order Assembler (HOA)	33
4.7 S4 Trail Termination (S4_TT)	36
4.8 Transport Terminal Function (TTF)	38
4.9 Equipment Management Function (EMF)	47
4.9.1 Configuration	49
4.9.2 Fault (maintenance) management	51
4.9.3 Performance management	51
4.10 Synchronous Equipment Timing Source (SETS)	55
4.11 Synchronous Equipment Timing Physical Interface (SETPI)	59
Annex A (normative): Block diagram of the Network Adapter (NA)	60
Annex B (informative): Mechanism of the adaptive clock method	61
Annex C (informative): Enabling/Disabling the Header Error Control functions (HEC)	62
Annex D (informative): Transmission capacity of the Network Adapter	63
Annex E (normative): Transport within Sub-STM-1 at 51 Mbit/s	64
Annex F (informative): Definition of codes	75
History	76

Blank page

Foreword

This European Telecommunication Standard (ETS) has been produced by the Joint Technical Committee (JTC) of the European Broadcasting Union (EBU), Comité Européen de Normalisation ELECtrotechnique (CENELEC) and the European Telecommunications Standards Institute (ETSI).

NOTE: The EBU/ETSI JTC was established in 1990 to co-ordinate the drafting of standards in the specific field of broadcasting and related fields. Since 1995 the JTC became a tripartite body by including in the Memorandum of Understanding also CENELEC, which is responsible for the standardization of radio and television receivers. The EBU is a professional association of broadcasting organizations whose work includes the co-ordination of its members' activities in the technical, legal, programme-making and programme-exchange domains. The EBU has active members in about 60 countries in the European broadcasting area; its headquarters is in Geneva.

* European Broadcasting Union
CH-1218 GRAND SACONNEX (Geneva)
Switzerland

Tel: +41 22 717 21 11
Fax: +41 22 717 24 81

Digital Video Broadcasting (DVB) Project

Founded in September 1993, the DVB Project is a market-led consortium of public and private sector organizations in the television industry. Its aim is to establish the framework for the introduction of MPEG2 based digital television services. Now comprising over 200 organizations from more than 25 countries around the world, DVB fosters market-led systems, which meet the real needs, and economic circumstances, of the consumer electronics and the broadcast industry.

Transposition dates	
Date of adoption of this ETS:	6 March 1998
Date of latest announcement of this ETS (doa):	30 June 1998
Date of latest publication of new National Standard or endorsement of this ETS (dop/e):	31 December 1998
Date of withdrawal of any conflicting National Standard (dow):	31 December 1998

Blank page

1 Scope

This European Telecommunication Standard (ETS) specifies the transmission of MPEG2 Transport Streams (TS) between two DVB interfaces as defined in EN 50083-9 [11] within SDH networks working at the ITU-T Recommendation G.707 [15] hierarchical bit rate of 155 520 kbit/s or at a bit rate of 51 840 kbit/s. The use of any of these bit rates is optional, if however one or more rates are selected the complete specification applies. The definition of the network aspects of the transmission of MPEG2-TSs is based to the maximum extent on existing international and European standards.

The equipment considered in this ETS is the Network Adapter (NA) performing the adaptation between MPEG2-TSs and the interfaces of SDH networks.

2 References

This ETS incorporates by dated and undated reference, provisions from other publications. These normative references are cited at the appropriate places in the text and the publications are listed hereafter. For dated references, subsequent amendments to or revisions of any of these publications apply to this ETS only when incorporated in it by amendment or revision. For undated references the latest edition of the publication referred to applies.

2.1 ETSI and CENELEC publications

- [1] ETS 300 147: "Transmission and Multiplexing (TM); Synchronous Digital Hierarchy (SDH)"; Multiplexing structure".
- [2] ETS 300 417-1-1: "Transmission and Multiplexing (TM); Generic functional requirements for Synchronous Digital Hierarchy (SDH) equipment; Part 1: Generic processes and performance".
- [3] ETS 300 417-2-1: "Transmission and Multiplexing (TM); Generic requirements of transport functionality of equipment; Part 2-1: Synchronous Digital Hierarchy (SDH) and Plesiochronous Digital Hierarchy (PDH) physical section layer functions".
- [4] ETS 300 417-3-1: "Transmission and Multiplexing (TM); Generic requirements of transport functionality of equipment; Part 3-1: Synchronous Transport Module-N (STM-N) regenerator and multiplex section layer functions".
- [5] ETS 300 417-4-1: "Transmission and Multiplexing (TM); Generic requirements of transport functionality of equipment; Part 4-1: Synchronous Digital Hierarchy (SDH) path layer functions".
- [6] ETS 300 417-6-1: "Transmission and Multiplexing (TM); Generic requirements of transport functionality of equipment; Part 6-1: Synchronization distribution layer functions".
- [7] EN 300 421: "Digital Video Broadcasting (DVB); Framing structure, channel coding and modulation for 11/12 GHz satellite services".
- [8] EN 300 429: "Digital Video Broadcasting (DVB); Framing structure, channel coding and modulation for cable systems".
- [9] ETS 300 462-1: "Transmission and Multiplexing (TM); Generic requirements for synchronization networks; Part 1: Definitions and terminology for synchronization networks".
- [10] ETS 300 462-5: "Transmission and Multiplexing (TM); Generic requirements for synchronization networks; Part 5: Timing characteristics of slave clocks suitable for operation in Synchronous Digital Hierarchy (SDH) equipment".

- [11] EN 50083-9: "Cabled distribution systems for television, sound and interactive multimedia signals; Part 9: Interfaces for CATV/SMATV headends and similar professional equipment for DVB/MPEG2 transport streams" (CENELEC).
- [12] ETR 290: "Digital Video Broadcasting (DVB); Measurement guidelines for DVB systems".

2.2 ITU publications

- [13] ITU-R Recommendation F.750-1: "Architectures and functional aspects of radio-relay systems for SDH-based networks".
- [14] ITU-T Recommendation G.703: "Physical/electrical characteristics of hierarchical digital interfaces".
- [15] ITU-T Recommendation G.707: "Network node interface for the synchronous digital hierarchy (SDH)".
- [16] ITU-T Recommendation G.783: "Characteristics of Synchronous Digital Hierarchy (SDH) equipment functional blocks".
- [17] ITU-T Recommendation G.825: "The control of jitter and wander within digital networks which are based on the synchronous digital hierarchy".
- [18] ITU-T Recommendation G.826: "Error performance parameters and objectives for international, constant bit rate digital paths at or above the primary rate".
- [19] ITU-T Recommendation H.222.0: "Information technology - Generic coding of moving pictures and associated audio information: Systems".
- [20] ITU-T Recommendation I.361: "B-ISDN ATM layer specification".
- [21] ITU-T Recommendation I.363.1: "B-ISDN ATM Adaptation Layer specification".
- [22] ITU-T Recommendation I.432: "B-ISDN User-Network Interface - Physical layer specification".
- [23] ITU-T Recommendation I.732: "Functional characteristics of ATM equipment".
- [24] ITU-T Recommendation J.82: "Transport of MPEG-2 constant bit rate television signals in B-ISDN".
- [25] ITU-T Recommendation M.2120: "PDH paths, section and transmission system and SDH path and multiplex section fault detection and localization procedures".
- [26] ITU-T Recommendation Q.822: "Stage 1, stage 2 and stage 3 description for the Q3 interface - Performance management".
- [27] ITU-T Recommendation G.957: "Optical interfaces for equipments and systems relating to the synchronous digital hierarchy".

3 Definitions and abbreviations

3.1 Definitions

For the purposes of this ETS, the following definitions apply:

fixed stuff: Bytes that are used to fill up unused data positions.

MPEG2-TS packet: A data packet possessing a length of 188 bytes including 4 bytes of header information. The header contains MPEG related data.

RS coded MPEG2-TS packet: A data packet possessing a length of 204 bytes. Bytes 1 to 188 contain an MPEG2-TS packet. Bytes 189 to 204 contain the parity-check bytes for the error correction of the preceding bytes of this packet. These parity-check bytes are generated using a shortened Reed-Solomon Code RS (204, 188).

3.2 Abbreviations

For the purposes of this ETS, the following abbreviations apply:

AAL	ATM Adaptation Layer
APS	Automatic Protection Switching
ASI	Asynchronous Serial Interface
ATM	Asynchronous Transfer Mode
AU	Administrative Unit
BER	Bit Error Rate
CATV	Community Antenna TeleVision
CRC	Cyclic Redundancy Check
CS	Convergence Sublayer
EMF	Equipment Management Function
FAS	Frame Alignment Signal
FEC	Forward Error Correction
HEC	Header Error Control
HOA	Higher Order Assembler
HOVC	Higher Order Virtual Container
LOF	Loss Of Frame
LOP	Loss Of Pointer
LOS	Loss Of Signal
LOVC	Lower Order Virtual Container
LSB	Least Significant Bit
MAA	MPEG ATM Adaptation
MMI	Man Machine Interface
MON	MONitored
MP	Management Points
MPEG	Motion Picture Expert Group
MPI	MPEG Physical Interface
MSB	Most Significant Bit
MSOH	Multiplex Section OverHead
NE	Network Element
PAPI	Path Access Point Identifier
PDU	Protocol Data Unit
POH	Path OverHead
PT	Path Trace
QOS	Quality Of Service
RDI	Remote Defect Indication
REI	Remote Error Indication
RFI	Remote Failure Indication
RR	Radio-Relay
RS	Reed-Solomon
RSOH	Regenerator Section OverHead
SAR	Segmentation And Reassembly Sublayer
SDH	Synchronous Digital Hierarchy
SETG	Synchronous Equipment Timing Generator
SETPI	Synchronous Equipment Timing Physical Interface
SETS	Synchronous Equipment Timing Source
SLC	Signal Label Checking
SMATV	Satellite Master Antenna TeleVision
SmTT	Sm Trail Termination
SN	Sequence Number
SOH	Section OverHead
SPI	Synchronous Parallel Interface
SSI	Synchronous Serial Interface
STM	Synchronous Transport Module
TCM	Tandem Connection Monitoring

TIM	Trace Identifier Mismatch
TS	Transport Stream
TTF	Transport Terminal Function
TTI	Trail Trace Identifier
TUG	Tributary Unit Group
UI	Unit Interval
UTC	Universal Time Co-ordinated
VC	Virtual Container
VP	Virtual Path
VPE	VP Entity
VPME	VP Multiplexing Entity

4 Baseline specification

The Network Adapter is an equipment which performs the adaptation of data structured as an MPEG2-TS [19] to the characteristics of an SDH link. The solution selected for the transmission of MPEG2-TS packets, respectively RS coded MPEG2-TS packets, over SDH links is based on the use of ATM cells. Therefore, the adaptation of the transport of an MPEG2-TS basically consists in:

- adaptation of MPEG2-TS packets or RS coded MPEG2-TS packets to ATM cells;
- adaptation of ATM cells to SDH framing.

The normative references applicable to the adaptation unless specifically mentioned are given here below:

- the adaptation of MPEG2-TS packets into ATM cells using an AAL type 1 shall be performed as described in ITU-T Recommendation J.82 [24]. AAL type 1 is specified in ITU-T-Recommendation I.363.1 [21], the ATM layer is specified in ITU-T Recommendation I.361 [20];
- the adaptation of ATM cells into SDH framing shall be performed as described in ITU-T-Recommendation G.707 [15].

There is no normative reference for the adaptation of RS coded MPEG2-TS packets to ATM cells. This adaptation shall be performed as described in ITU-T Recommendation J.82 [24] for MPEG2-TS packets, with the only exception that the RS coded MPEG2-TS packets are not aligned with the structure of the AAL1 interleaving matrix.

The Network Adapter (NA) is described as a group of functional blocks. The partitioning into functional blocks is based on existing recommendations on SDH equipments (ITU-T Recommendation G. 783 [16]) and ATM equipments (ITU-T Recommendation I.732 [23]). The equipment consists of the following blocks (see also figure 1):

- MPEG Physical Interface;
- MPEG / ATM Adaptation;
- Virtual Path Entity;
- VP Multiplexing Entity;
- Sm Trail Termination;
- Higher Order Assembler;
- S4 Trail Termination;
- Transport Terminal Function;
- Synchronous Equipment Timing Source;
- Synchronous Equipment Timing Physical Interface; and
- Equipment Management Function.

The present description is a functional description and does not imply any specific equipment implementation but it allows for the implementation of a separate transmitter and receiver as well as a combined transmitter / receiver.

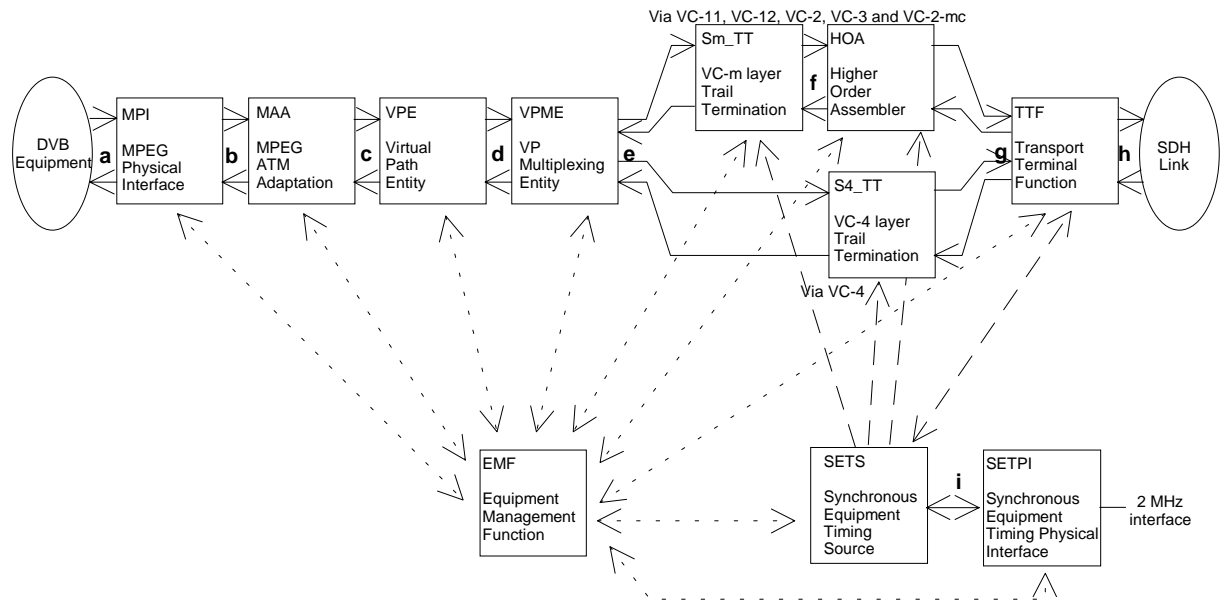

Figure 1: Functional blocks of the Network Adapter

NOTE: Most of ATM functional blocks contained in ITU-T Recommendation I.732 [23] do not appear in figure 1 as they are not relevant for the adaptation. Furthermore, the blocks "Higher Order Assembler" and "Transport Terminal Function" consist of several sub-blocks that reflect the description of the functional structure of SDH equipment following the recommendations given in ETS 300 417-2-1 [3], ETS 300 417-3-1 [4] and ETS 300 417-4-1 [5]. A fully detailed block diagram of the Network Adapter is given in annex A.

This adaptation corresponds to the protocol stack shown in figure 2:

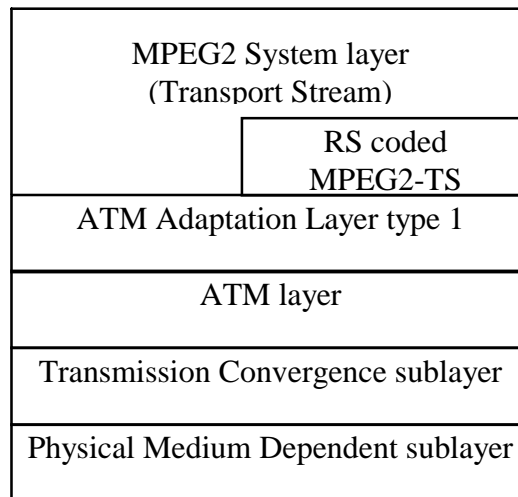

Figure 2: Protocol stack for the adaptation process

The following functional blocks are identified:

- *The MPEG2-TS Physical Interface:* the Network Adapter accepts, at its input port, either an MPEG2-TS consisting of consecutive MPEG2-TS packets, or an extended version of an MPEG2-TS that already contains error protection (RS coded MPEG2-TS packets). Packets length of 188 bytes and 204 bytes can be handled.
- *The MPEG / ATM Adaptation:* this corresponds to the adaptation between the MPEG2-TS respectively the RS coded MPEG2-TS and the ATM cells via an AAL type 1. This adaptation, besides format adaptation, provides functions for the MPEG2-TS clock transmission transparency (adaptive clock method) and information transparency using the clock and data recovery

mechanism of AAL1. It is expected that under normal transmission conditions the received MPEG2-TS will be quasi error free, corresponding to a Bit Error Rate (BER) of about 10^{-10} to 10^{-11} at the input of an MPEG2 equipment at the receiver site. This requirement is in accordance with the standards for the DVB systems using satellite services (see ETS 300 421 [7]) and cable systems (see ETS 300 429 [8]).

- *The Virtual Path Entity:* the only function performed is the VP setting. It allows the simultaneous transmission of several independent MPEG2-TS on one SDH link.
- *The VP Multiplexing Entity:* if different MPEG2-TS have to be simultaneously transported, the ATM cells belonging to different VPs are multiplexed in the transmitter respectively demultiplexed in the receiver. If only one MPEG2-TS has to be transported, only one VP is used. The adaptation to the useful bit-rate offered by the SDH link is performed by adding respectively removing idle cells. At the receiver, this block also performs cell delineation and ATM cell header checking.
- *The Sm Trail Termination:* this block generates and adds the error monitoring, the status and the control OverHead information to lower order Virtual Containers (VC-11, VC-12, VC-2 or VC-3) at the transmitter site. In the receiver the appropriate Virtual Containers are monitored for errors and the payload independent OverHead information is extracted.
- *The S4 Trail Termination:* this block generates and adds the error monitoring, the status and the control OverHead information to a Virtual Container VC-4 at the transmitter site. In the receiver the Virtual Container VC-4 is monitored for errors and the payload independent OverHead information is extracted.
- *The Higher Order Assembler:* in the transmitter, this block is responsible for the multiplexing of lower order VCs into a VC-4, for the processing of the relevant pointers and for the setting of a part of the VC4-POH. In the receiver, parts of the VC4-POH are evaluated and the pointer information is used in order to ensure a correct demultiplexing of the VC-4 contents into lower order VCs.
- *The Transport Terminal Function:* The AU-4 pointer is processed respectively evaluated to indicate the phase of the first byte of the VC-4-POH relative to the first byte of the STM-1 SOH. Additionally, this function generates the MSOH and the RSOH in the process of forming an SDH frame signal and terminates these types of OverHead information in the receiver. The STM-1 frame is scrambled/descrambled and the appropriate signal at the physical interface is created in the transmitter respectively converted into an internal logical signal in the receiver.
- *The Synchronous Equipment Timing Source:* this function provides timing reference to relevant parts of an SDH equipment and represents the SDH Network Element clock.
- *The Synchronous Equipment Timing Physical Interface:* this function provides the interface between an external synchronization signal and the SETS. It also provides a 2 MHz synchronization output signal.
- *The Equipment Management Function:* this block manages all the other functional blocks. It ensures the Man Machine Interface.

The processing of the MPEG data for the transmission inside an SDH network can be done using several types of Virtual Containers depending on the wanted payload capacity. It is not mandatory to implement all types of VC processing inside the Network Adapter. If however one or more types of VC processing are selected as described in this present document the complete specification applies.

Unless otherwise mentioned, in this ETS the following conventions hold true: the order of transmission of information in all diagrams is first from left to right and then from top to bottom. Within each byte or octet the Most Significant Bit (MSB) is transmitted first.

4.1 MPEG Physical Interface (MPI)

This function provides the interface between the Network Adapter and the MPEG2-TS sources or receivers. The physical characteristics of this interface shall follow the specification given in EN 50083-9 [11]. Three different types of interfaces are specified.

They are called:

- the Synchronous Parallel Interface (SPI);
- the Synchronous Serial Interface (SSI);
- the Asynchronous Serial Interface (ASI).

The interfaces use the MPEG2-TS Packet structure (188 bytes) or the RS-coded packet structure (204 bytes). For the SPI and the SSI, the 204-byte format may be used either for the transmission of 188-byte MPEG2-TS packets with 16 dummy bytes, or for the transmission of 204-byte RS-coded packets.

In order to prevent alarms being raised and failures being reported during set-up procedures or if the input port is not in use (in the case of a multi-port equipment), the MPI function shall have the ability to enable or disable fault case declaration. The MPI shall be either monitored (MON) or not monitored (NMON). The state MON or NMON is provisioned by the equipment manager to the MPI via the EMF function.

Signal processing in the transmitter (Signal flow from a-to-b in figure 1)

a) Recovery of MPEG2 packets

This function recovers the data bytes and their clock from the received signals:

- For the SPI, this recovery is based on the use of the Data (0-7), the DVALID, PSYNC and clock signals, as specified in paragraph 4.1 of EN 50083-9 [11].
- For the SSI interface, the processing includes optical receiver (for fibre-optic-based link) or coupling/impedance matching (for coaxial cable), amplifier/buffer, clock recovery and biphasic decoding, serial to parallel conversion, as specified in annex A of EN 50083-9 [11].
- For the ASI interface, the processing includes optical receiver (for fibre-optic-based link) or coupling/impedance matching (for coaxial cable), amplifier/buffer, clock/data recovery and serial-to-parallel conversion, FC comma deletion, 8B/10B decoding, as specified in annex B of EN 50083-9 [11]. In the next step, the recovery of the TS clock is performed (cf. annex E of EN 50083-9 [11]: implementation guidelines and deriving clocks from the MPEG2 packets for the ASI).

The function also realizes the sync acquisition of the MPEG2-TS packets respectively of the RS-coded MPEG2-TS packets, on the basis of the method proposed in subclause 3.2 of ETR 290 [12] (five consecutive correct sync bytes for sync acquisition; two or more consecutive corrupted sync bytes should indicate sync loss).

The packet size (188 bytes or 204 bytes) may be recovered from the received signals, on the basis of the PSYNC signal for the parallel interface, or on the basis of periodicity of the synchronization bytes for the serial interfaces. For the case of the Synchronous Parallel Interface and of the SSI interface, the decision between 204-byte format for MPEG2-TS packets with 16 dummy bytes and 204-byte format for RS-coded MPEG2-TS packets can be made:

- on the basis of the DVALID signal for the SPI: a high level during the last 16 bytes indicate RS redundancy bytes (paragraph 4.1.1 of EN 50083-9 [11]); or
- on the basis of the value of received synchronization bytes for the SSI interface: 47H indicates 204 byte format with 16 dummy bytes and B8H indicates 204-byte RS coded (paragraph A.3.2 of EN 50083-9 [11]). For the RS coded transmission the synchronization byte has to be changed to 47H.

For the case of the ASI Interface, the following decision is taken: If the packet size is 204 bytes, it is an RS-coded MPEG2-TS packet.

Dummy bytes are discarded by the MPI function in the case of the 204-byte format with 16 dummy bytes.

The function passes the recovered MPEG2-TS packets or the RS coded MPEG2-TS packets and the timing information to point b of figure 1.

The function shall meet the electrical/optical characteristics, return loss and jitter requirements specified in EN 50083-9 [11].

This function shall also detect:

- the absence of valid input signals;
- the absence of clock;
- a DVALID signal constantly low in the case of the Synchronous Parallel Interface (SPI).

If any of these defects is detected, a Loss Of Signal (LOS) is reported at the EMF if the function is in MON state.

If a loss of synchronization of MPEG2-TS packets or RS coded MPEG2-TS packets is detected according to the procedure proposed in the subclause 3.2 of ETR 290 [12] (i.e. two or more consecutive corrupted sync bytes are found), a TS-sync_loss error on the input signal (TSLE_I) is reported at the EMF if the function is in MON state.

b) Performance monitoring

Errored blocks are detected on the basis of the transport_error_indicator present in the headers of the incoming MPEG2-TS packets, in accordance to ETR 290 [12]. One second filters perform a simple integration of errored blocks by counting during one second interval. The function generates the following performance parameters concerning the input MPEG2-TS signal received on the interface:

- N_EBC_I: every second, the number of errored blocks within that second is counted as the Near-End Error Block Count (N_EBC_I).
- N_DS_I: every second with at least one occurrence of TSLE_I or LOS (corresponding to the notion of Severely Disturbed Period introduced in ETR 290 [12]) shall be indicated as Near-End Defect Second (N_DS_I).

If the function is in the MON state, at the end of each one second interval, the contents of the N_EBC_I counter and of the N_DS_I indicator are reported to the EMF. Furthermore, on request of the EMF block, the MPI block evaluates and reports to the EMF the number of received MPEG2-TS packets within one second (BC_I).

Signal processing in the receiver (Signal flow from b-to-a in figure 1)

a) Generation of the signals at the MPEG Physical interface

This function receives the data bytes provided at the reference point b of figure 1 by the MAA block and recovers the synchronization of the MPEG2-TS packets or of the RS coded MPEG2-TS packets on the basis of the method proposed in subclause 3.2 of ETR 290 [12] (five consecutive correct sync bytes for sync acquisition; two or more consecutive corrupted sync bytes should indicate sync loss). The type of packet (MPEG2-TS packet or RS-coded MPEG2-TS packet) is determined on the basis of the periodicity of the synchronization bytes. After the recovery of the packet structure and only in the case of a MPEG2-TS packet structure, the function shall use the status indicator of the AAL-SAP (available at reference point b) to set the transport_error _indicator of the MPEG2-TS packets.

The function determines the transmission format to be used at the output interface according to the following table 1:

Table 1: Transmission format of the output interface

Type of packets received by the MPI block	Transmission format on the physical interface	
MPEG2-TS packets (188 bytes)	SPI, SSI	188-byte packets or 204-byte packets with 16 dummy bytes, according to the parameter FORMAT provided by the EMF block.
	ASI	188-byte packets
RS-coded MPEG2-TS packets (204 bytes)	SPI, SSI, ASI:	204-byte packets

The function generates the appropriate signals at the output interface, according to the type of physical interface and to the transmission format selected:

- For the Synchronous Parallel Interface (SPI), the function generates the Data (0-7), the DVALID, PSYNC and clock signals, as specified in paragraph 4.1 of EN 50083-9 [11].
- For the SSI interface, the processing includes parallel to serial conversion, biphase coding, amplifier/buffer and optical emitter (for fibre-optic-based link) or coupling/impedance matching (for coaxial cable), as specified in annex A of EN 50083-9 [11].
- For the ASI interface, the processing includes 8B/10B coding, FC comma symbols insertion, parallel-to-serial conversion, amplifier buffer and optical emitter (for fibre-optic-based link) or coupling/impedance matching (for coaxial cable), as specified in annex B of EN 50083-9 [11].

The function shall meet the electrical/optical characteristics, return loss and jitter requirements specified in EN 50083-9 [11].

If a loss of synchronization of MPEG2-TS packets or of the RS coded MPEG2-TS packets is detected according to the procedure proposed in the subclause 3.2 of ETR 290 [12] (i.e. two or more consecutive corrupted sync bytes are found), a TS-sync_loss error for the output signal (TSLE_O) is reported at the EMF if the function is in MON state.

b) Performance monitoring

Errored blocks are detected on the basis of the transport_error_indicator present in the headers of the MPEG2-TS packets regenerated in the MPI block, in accordance to ETR 290 [12]. One second filters perform a simple integration of errored blocks by counting during one second interval. The function generates the following performance parameters concerning the output MPEG2-TS signal delivered by the interface:

- N_EBC_O: every second, the number of errored blocks within that second is counted as the Near-End Error Block Count (N_EBC_O).
- N_DS_O: every second with at least one occurrence of TSLE_O or LOS (corresponding to the notion of Severely Disturbed Period introduced in ETR 290 [12]) shall be indicated as Near-End Defect Second (N_DS_O).

If the function is in the MON state, at the end of each one second interval, the contents of the N_EBC_O counter and of the N_DS_O indicator are reported to the EMF. Furthermore, on request of the EMF block, the MPI block evaluates and reports at the EMF the number of received MPEG2-TS packets within one second (BC_O).

4.2 MPEG/ATM Adaptation (MAA)

The MPEG/ATM Adaptation (MAA) utilizes the AAL type 1. The AAL type 1 is described in ITU-T Recommendation I.363.1 [21] where its functions are described for all corresponding applications. Specifically, the utilization of the AAL 1 for the transport of MPEG2 constant bit rate television signals is described in ITU-T Recommendation J.82 [24] clause 7. As a result, the description of the MPEG/ATM Adaptation is based on ITU-T Recommendation J.82 [24] clause 7. The structure of AAL type 1 is given in figure 3. The SAR-PDU (Segmentation And Reassembly - Protocol Data Unit) payload of 47 octets is headed by an SAR-PDU header of 8 bits. For the transmission the payload data is protected by an FEC scheme.

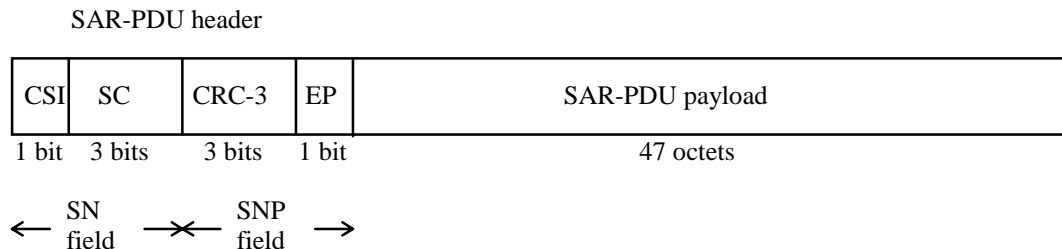

Figure 3: Structure of AAL type 1

To prevent alarms being raised and failures being reported during set-up procedures, or if the input port is not in use (in the case of a multi-port equipment), the MAA function shall have the ability to enable or disable fault case declaration. The MAA shall either be monitored (MON) or not monitored (NMON). The state MON or NMON is provisioned by the equipment manager to the MAA via the EMF function.

Signal processing in the transmitter (Signal flow from b-to-c in figure 1)

The MAA accepts signals from the MPI and conveys them to the VPE by using a transmitting AAL1. From the protocol stack point of view, signals are transported from the AAL-SAP (AAL-Service Access Point) to the ATM-SAP.

Functions to be performed are those of the AAL1-CS (Convergence Sublayer) and of the AAL1-SAR (Segmentation and Reassembly). The results of this functions are used to set the appropriate fields of the SAR-PDU header. The SAR Sublayer accepts a 47 octet block of data from the CS layer and prepends a one-octet SAR-PDU header.

a) Handling of user information (CS function)

In compliance with ITU-T Recommendation J.82 [24] paragraph 7.1 the length of the AAL-SDU (Service Data Unit) is one octet.

b) Handling of lost and misinserted cells (SC field) (CS function)

In the transmitting CS this function is related to the Sequence Count (SC) processing. After processing, the 3-bit sequence count value is passed to the transmitting SAR in order to be inserted in the SC field of the SAR-PDU header (see ITU-T Recommendation J.82 [24] paragraph 7.3).

c) Handling of the timing relationship (CS function)

As it is stated in ITU-T Recommendation J.82 [24] paragraph 7.4, the adaptive clock method shall be used. In this method, no function is to be performed in the transmitting CS.

d) Forward error correction for SAR-PDU payload (CS function)

This function is performed by the method described in detail in ITU-T Recommendation I.363.1 [21] paragraph 2.5.2.4.2. As stated in ITU-T Recommendation J.82 [24], paragraph 7.5, this method shall be used.

Basically the method combines octet interleaving (the size of the interleaver is 128×47 octets), and FEC using RS (124,128) codes.

In the transmitting CS, 4 octets of RS code are appended to 124 successive octets of incoming data from the AAL-SAP. The resulting 128 octet long blocks are then forwarded to the octet interleaver. See figure 4 for the format of the interleaver matrix.

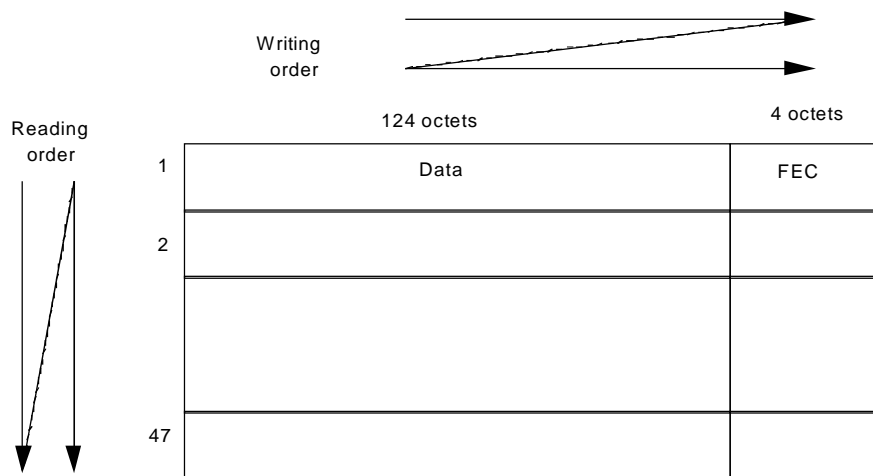

Figure 4: Structure and format of the interleaver matrix

The octet interleaver is organized as a matrix of 128 columns and 47 rows. In the transmitting CS, the interleaver is operated as follows: at the input, incoming 128 octet long blocks are stored row by row (one block corresponding to one row); at the output, octets are read out column by column. The matrix has $128 \times 47 = 6\,016$ octets, corresponding to 128 SAR-PDU payloads. These 128 SAR-PDU payloads constitute one CS-PDU.

When MPEG2-TS packets of 188 octets are transmitted by the MPI, then the interleaver contains exactly 31 MPEG2-TS packets; in the case when RS coded MPEG2-TS packets of 204 octets are transmitted, then the number of RS coded MPEG2-TS packets contained in the interleaver is not an integer number. This has no impact on the processing.

Columns from the interleaver are then passed to the SAR where a SAR-PDU header is put in front of each of them.

e) Synchronization of the CS-PDU (CS function)

The CSI bit is used to synchronize the interleaving matrix, i.e. the CS-PDU. Following ITU-T Recommendation J.82 [24], subclause 7.5, the CSI bit is set to "1" for the first SAR-PDU payload of the CS-PDU.

f) Protection of the sequence number field (SAR function).

The first four bits of every SAR-PDU header form the sequence number (SN) field. This SN field is protected by a 3 bit CRC code following the calculation described in subclause 2.4.2.2 of ITU-T Recommendation I.363.1 [21]. The result of this calculation, the remainder of the division (modulo 2) by the generator polynomial $x^3 + x + 1$ of the product x^3 multiplied by the content of the SN field, is written into the CRC field.

g) Protection of the SAR-PDU header (SAR function).

The first seven bits of each SAR-PDU header are protected by an even parity check bit that is written into bit EP of the actual SAR-PDU header.

The AAL1 SAR passes 48 octet blocks to the VPE.

Signal processing in the receiver (Signal flow from c-to-b in figure 1)

The MAA receives signals from the VPE block and conveys them to the MPI block by using a receiving AAL1. From the protocol stack point of view, signals are transported from the ATM-SAP (ATM-Service Access Point) to the AAL-SAP.

Functions to be performed are those of the AAL1-SAR (Segmentation and Reassembly) and of the AAL1-CS (Convergence Sublayer). The content of the SAR-PDU header is evaluated in order to specify relevant functions of the AAL1-SAR respectively of the AAL1-CS.

The MAA receives from the VPE 48 octet long blocks corresponding to cell payloads. The SAR separates the SAR-PDU header (one octet) and passes the 47 octet block of data to the receiving CS.

a) Evaluation of the SNP field (CRC-3 field and EP bit) (SAR function)

The SAR protocol is described in ITU-T Recommendation I.363.1 [21] subclause 2.4.2. After processing of the SNP field (Sequence Number Protection) the Sequence Count field and the CSI bit are passed to the receiving CS together with the SN check status indicator (valid or invalid). The use of the SN check status together with the considered processing is described in detail in ITU-T Recommendation I.363.1 [21], paragraph 2.4.2.2 and in table 1 of ITU-T Recommendation I.363.1 [21].

If the SN check status indicator has been set to invalid, a SNI (Sequence Number Invalid) indication is forwarded to the EMF.

b) Handling of user information (CS function)

In compliance with ITU-T Recommendation J.82 [24] paragraph 7.1, the length of the AAL-SDU (Service Data Unit) is one octet and the status parameter is used. As mentioned in ITU-T Recommendation I.363.1 [21], the status parameter possesses two values: "valid" and "invalid". "Invalid" is used in the case where errors have been detected and have not been corrected (for the use of this parameter see description under e)).

c) Handling of lost and misinserted cells (CS function)

Detection of lost and misinserted cell events is performed by using the Sequence Count (SC) value transmitted by the receiving SAR. The CS processing for SC operation is described in detail in ITU-T Recommendation I.363.1 [21], paragraph 2.5.2.1.2.

In the receiving AAL1-CS, the processing is as follows: the SC is processed in order to detect cell loss events. In case of a detected cell loss, 47 dummy octets are inserted in the signal flow in order to maintain bit count integrity. Detected misinserted cells are merely discarded.

Lost and Misinserted Cells (LMC) events are transmitted to the EMF.

d) Handling of the timing relationship (CS function)

The end to end synchronization function is performed by the adaptive clock method described in ITU-T Recommendation I.363.1 [21] paragraph 2.5.2.2.2. A short description of the method is given in informative annex B. It is pointed out that the adaptive clock method does not need any external clock to be operated.

e) Correction of bit errors and lost cells (CS function)

In the receiving AAL1-CS, the mechanism in the interleaver is the inverse of that of the transmitting interleaver, i.e. the writing order is vertically and the reading order is horizontally. Informations are stored in the receiving interleaver column by column. In the case of insertion of dummy octets, an indication is provided in order to enable the use of the erasure mode of the RS codes. After the whole interleaving matrix has been stored, it is read out block by block to the RS decoder where errors and erasures are corrected.

Correction capabilities are up to 4 cell losses in a group of 128 cells and up to 2 errored octets in a block of 128 octets. It ensures that under normal transmission condition, the received MPEG2-TS flow is quasi error free.

If the RS decoder is unable to correct the errors, then the "status" indicator of the AAL-SAP shall be used (see ITU-T Recommendation J.82 [24] paragraph 7.1.) in order to signal this error. The indicator is passed to the MPI block and to the EMF.

4.3 Virtual Path Entity (VPE)

Among all the functions referenced in ITU-T Recommendation I.732 [23] for this functional block, only the VP setting is ensured. This function only concerns the signal flow from point c to point d in figure 1. The ATM cell header that contains the virtual path identifier VPI is organized as shown in figure 5.

8	7	6	5	4	3	2	1	bit byte
Generic Flow Control GFC				Virtual Path Identifier VPI				1
Virtual Path Identifier VPI				Virtual Channel Identifier VCI				2
Virtual Channel Identifier VCI								3
Virtual Channel Identifier VCI				Payload Type Field PT		CLP		4
Header Error Control HEC								5

Figure 5: Structure of an ATM cell header

Signal processing in the transmitter (Signal flow from c-to-d in figure 1)

VP setting: The VPI value is processed in accordance with the assigned values. As far as no VC related block is implemented in the Network Adapter, VC setting is also performed in this block to the fixed value 0020h. VPI value 00h is forbidden. Any other value may be used. However, it is suggested to use the VPI values listed in table 2:

Table 2: Default values for the setting of the VPI

Number of MPEG2-TS to be simultaneously transported	MPEG2-TS number	VPI value
1	MPEG2-TS n° 1	11h
2	MPEG2-TS n° 1	11h
	MPEG2-TS n° 2	12h
3	MPEG2-TS n° 1	11h
	MPEG2-TS n° 2	12h
	MPEG2-TS n° 3	13h
4	MPEG2-TS n° 1	11h
	MPEG2-TS n° 2	12h
	MPEG2-TS n° 3	13h
	MPEG2-TS n° 4	14h
5	MPEG2-TS n° 1	11h

	MPEG2-TS n° 4	14h
6	MPEG2-TS n° 5	15h
	MPEG2-TS n° 6	16h
	MPEG2-TS n° 7	17h
7	MPEG2-TS n° 1	11h

	MPEG2-TS n° 6	16h
	MPEG2-TS n° 7	17h
8	MPEG2-TS n° 1	11h

	MPEG2-TS n° 8	18h

The VPI values used are settable by the EMF. The default values used are in accordance with table 2.

Signal processing in the receiver (Signal flow from d-to-c in figure 1)

No function of the VPE is implemented in this direction.

4.4 Virtual Path Multiplexing Entity (VPME)

This functional block is responsible for the adaptation between an ATM cell structure and a SDH transmission path structure (VC-4, VC-3, VC-2, VC-12, VC-11, VC-2-mc). In addition, this block processes the payload dependent informations in the Path OverHead POH of the several Virtual Containers: H4, C2, F2 and F3 bytes in case of ATM cells mapping into VC-4 or VC-3, and bits 5, 6 and 7 of V5 byte in case of ATM cells mapping into VC-2, VC-12, VC-11 or VC-2-mc.

The VC-3 POH and the VC-4 POH consists of 9 bytes denoted J1, B3, C2, G1, F2, H4, F3, K3 and N1. For a description of the VC-3 POH, see the description in subclause 4.5.1. For a description of the VC-4 POH, see the description in subclause 4.7.

The VC-2 POH, the VC-11 POH and the VC-12 POH consists of 4 bytes denoted V5, J2, N2 and K4. For a description of these OverHead bytes, see the description in subclause 4.5.2.

The partitioning of the VPME into functional blocks as described below is in accordance with ITU-T Recommendation I.732 [23]. The organization of the ATM cell header which content is partly set in this functional block is shown in figure 5.

In order to prevent alarms being raised and failures being reported during path provisioning, the VPME function shall have the ability to enable or disable fault cause declaration. The Virtual Path Multiplexing Entity shall be either monitored (MON) or not monitored (NMON). The state MON or NMON is provisioned by the equipment manager to the VPME via the EMF function. The state of the VPME and the associated TTF shall be identical.

Signal processing in the transmitter (Signal flow from d-to-e in figure 1)

VP multiplexing: This function enables individual cell flows to be logically combined into a single cell flow according to the VPI values.

Congestion control: This function is not used in this equipment. The cell loss priority bit CLP shall be set to "0" (corresponding to high cell priority in ATM terminology).

GFC: This function is not used in this equipment. The GFC field shall be set to "0000" (corresponding to uncontrolled equipment in ATM technology).

PT field: This function is not used in this equipment. The three bits of the PT field shall be set to "000".

Cell rate decoupling: Idle cells are inserted into the cell stream in order to match the rate of the SDH transmission path payload (i.e. the useful rate of the VC) in accordance with ITU-T Recommendation I.432 [22]. The format of the idle cell shall be in accordance with ITU-T Recommendation I.432 [22]. It is described here below:

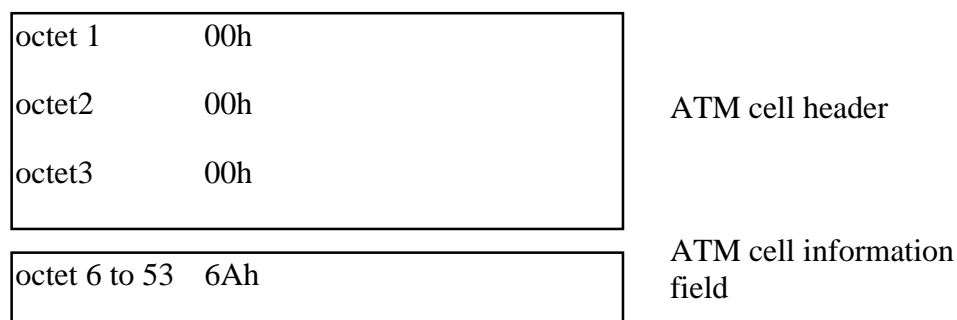

HEC processing: The HEC value for each cell is calculated and inserted into the HEC field. The method of HEC value calculation shall be in accordance with ITU-T Recommendation I.432 [22]. Basically the HEC field is the remainder of the division (modulo 2) by the generator polynomial $x^8 + x^2 + x + 1$ of the product x^8 multiplied by the content of the header excluding the HEC field, to which is added the value 55h.

Scrambling: The information field of each cell is scrambled with a self synchronizing scrambler $x^{43} + 1$. The operation of the scrambler shall be in accordance with ITU-T Recommendation I.432 [22].

Cell stream mapping: The cell stream shall be inserted into VC as specified in ITU-T Recommendation G.707 [15] subclause 10.2.2 in case of VC-4/VC-3, subclause 10.2.3 in case of VC-2-mc, subclause 10.2.4 in case of VC-2 and subclause 10.2.5 in case of VC-12/VC-11. The cell stream byte boundaries are aligned with the container byte boundaries.

H4, F2 and F3 bytes (applicable only in case of ATM cells mapping into VC-4 or VC-3): These bytes are undefined.

C2 byte (applicable only in case of ATM cells mapping into VC-4 or VC-3): This byte shall be set to "00010011" corresponding to ATM payload as specified in table 7 of ITU-T Recommendation G.707 [15].

Bits 5, 6 and 7 of V5 byte (applicable only in case of ATM cells mapping into VC-2-mc, VC-2, VC-12 or VC-11): These bits shall be set to "001" as specified in ITU-T Recommendation G.707 [15].

Signal processing in the receiver (Signal flow from e-to-d in figure 1).

Data at point e is a container with defined H4, F2, F3 and C2 bytes in case of C-4 and C-3 or with defined bits 5, 6 and 7 of V5 bytes in case of C-2, C-12, C-11 or C-2-mc.

H4, F2, F3 and C2 bytes (applicable only in case of ATM cells mapping into VC-4 or VC-3): These bytes are ignored.

Bits 5, 6 and 7 of V5 byte (applicable only in case of ATM cells mapping into VC-2-mc, VC-2, VC-12 or VC-11): These bits are ignored.

Cell stream demapping: The cell stream shall be extracted from the VC-4, VC-3, VC-2, VC-12, VC-11 or VC-2-mc as specified in ITU-T Recommendation G.707 [15]. The cell stream byte boundaries are aligned with the container byte boundaries.

Cell delineation: Cell delineation is performed on the continuous cell stream extract from the transmission path frames. The cell delineation algorithm shall be in accordance with ITU-T Recommendation I.432 [22]. Basically it bases on the correlation between the header bits to be protected (32 bits) and the relevant control bits (8 bits) introduced in the header by the HEC. Cell delineation is deemed to be lost causing a LCD defect after 7 consecutive incorrect HECs. Cell delineation is deemed to be recovered after 6 consecutive correct HECs. If the function is in the MON state, the LCD defect is reported to the EMF.

Descrambling: The information field of each cell is descrambled with a self-synchronizing scrambler polynomial $x^{43} + 1$. The operation of the descrambler shall be in accordance with ITU-T Recommendation I.432 [22].

HEC processing: HEC verification and correction bases on the methods described in ITU-T Recommendation I.432 [22]. The HEC correction mode may be activated/deactivated by the EMF. In case of cells determined to have an invalid and inconvertible HEC pattern, two options are possible. Either the invalid cells may be discarded (in accordance with ITU-T Recommendation I.432 [22]) or the invalid cells may not be discarded (not in accordance with ITU-T Recommendation I.432 [22]). The wanted option is selected by the EMF. Further information is given in the informative annex C.

Cell rate decoupling: Idle cells are extracted from the cell stream. They are identified by the standardized pattern for the cell header.

PT identification: This function is not implemented. The corresponding bits are ignored.

Cell header verification: The receiving NA shall verify that the first four octets of the ATM cell header are recognizable as being a valid header pattern. Invalid header pattern are (p = any value):

GFC	VPI	VCI	PT	CLP
pppp	0000 0000	0000 0000 0000 0000	ppp	1

Idle cells are discarded.

GFC check: This function is not implemented. The corresponding bits of the GFC field are ignored.

VPI verification: The receiving Network Adapter shall verify that the VPI of the received cell is valid. If the VPI is determined to be invalid (i.e. out of range or unassigned - see subclause 4.3, item "VP setting"), the cell shall be discarded.

Congestion control: This function is not implemented. The corresponding bit CLP is ignored.

VP demultiplexing: This function enables the flow of cells which have to be logically separated into individual data flows according to their VP values.

4.5 Sm Trail Termination (Sm_TT)

This function acts as a source and sink for the POH payload independent information of the lower order VC.

Four types of Sm-TT are defined for the following lower order VCs of ITU-T Recommendation G.707 [15]:

- VC-3 Trail Termination (S3_TT);
- VC-2 Trail Termination (S2_TT);
- VC-12 Trail Termination (S12_TT);
- VC-11 Trail Termination (S11_TT).

The transmission capacity at each VC bit rate for the MPEG2-TS respectively the RS-coded MPEG2-TS is given in informative annex D taking into account the RS (128, 124) code and the data amount of the SAR-PDU header.

4.5.1 S3 Trail Termination (S3_TT)

The VC-3 frame structure defined in ITU-T Recommendation G.707 [15] shall be used. The VC-3 frame comprises 756 octets of payload and 9 octets of path OverHead (POH) as shown in figure 6. The VC-3 POH is located in the first column of the 9-rows by 85-columns VC-3 structure.

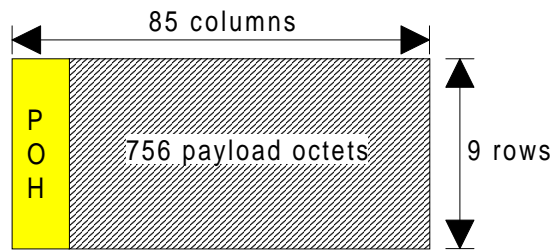

Figure 6: VC-3 frame structure

The content of the VC-3 POH is described in ITU-T Recommendation G.707 [15] and in ETS 300 417-1-1 [2] and ETS 300 417-4-1 [5].

- Byte J1 (path trace): This is the first byte in the virtual container, its location in the VC-4 frame is indicated by the associated TU-3 pointer. This byte is used to transmit repetitively a Path Access Point Identifier so that a path receiving terminal can verify its continued connection to the intended transmitter. The value of this byte shall follow the recommendations given in subclause 7.1 of document ETS 300 417-1-1 [2].
- Byte B3 (BIP-8): This byte is used for bit error monitoring. It uses a Bit Interleaved Parity BIP-8 using even parity as described in subclause 9.3.1.2 of ITU-T Recommendation G.707 [15].
- Byte C2 (signal label): This byte indicates the composition or the maintenance status of the VC-3. Table 7 in ITU-T Recommendation G.707 [15] provides appropriate codes for this byte.
- Byte G1 (Path status): This byte is allocated to send back to a VC-3 trail termination source the path status and performance as detected by a trail termination sink using Remote Defect Indication (RDI) and Remote Error Indication (REI). The allocation of the bits shall be done in accordance with the description given in subclause 5.2.1 of ETS 300 417-4-1 [5].
- Bytes F2 and F3 (Path user channels): These bytes are allocated for user communication purposes between path elements and are payload dependant.
- Byte H4 (position indicator): This byte is payload specific.
- Byte K3 (APS channel + spare): Bits 1 to 4 are allocated for APS signalling for protection at the VC-3 path levels. Bits 5 to 8 are undefined.
- Byte N1 (Network operator byte): This byte is allocated to provide Tandem Connection Monitoring (TCM) function.

Table 3 indicates for each of the VC-3 POH bytes if they are used in the context of the SDH network adapter and, if necessary, any setting of particular value.

NOTE 1: Some of these bytes are processed by the VPME function.

Table 3: VC-3 POH

VC-3 POH bytes	Used	Particular value
J1 - Path Trace	Yes	-
B3 - BIP-8	Yes	-
C2 - Signal Label	Yes (see VPME)	Set to "00010011"
G1 - REI + RDI + spare	Yes	-
F2 - Path user channel	No (see VPME)	Undefined
H4 - Position indicator	No (see VPME)	Undefined
F3 - Path user channel	No (see VPME)	Undefined
K3 - APS + spare	No	Undefined
N1 - Network operator byte	No	Undefined

Signal processing in the transmitter (Signal flow from e-to-f in figure 1)

Data at point e is a VC-3 with undefined POH bytes J1, B3 and G1.

In the transmitter, this function generates and adds the error monitoring, status and control OverHead information (bytes J1, G1 and B3) to the VC-3 POH.

a) Path Trace (Byte J1)

This byte conveys a Path Trace that is provisioned by the EMF using a format as described in subclause 5.2.1 of ETS 300 417-4-1 [5].

b) BIP-8 Calculation (Byte B3)

The calculation shall be done according to the description given in subclause 5.2.1 of ETS 300 417-4-1 [5].

c) Path Status (Byte G1)

Bits 1 through 4 convey the count of blocks that have been detected in error by the trail termination sink using the information of Byte B3 for an REI. Bit 5 is used to indicate a path RDIndication. Bits 6 through 8 are undefined. The values of these bits shall be set according to subclause 5.2.1 of ETS 300 417-4-1 [5].

NOTE 2: In case of unidirectional transmission, there is no associated path termination and the byte G1 shall be set to a logical "0".

Bytes K3 and N1 are undefined.

Signal processing in the receiver (Signal flow from f-to-e in figure 1)

Data at point f is a VC-3 with fully defined POH.

In the sink direction, this function monitors VC-3 for errors and extracts the payload independent OverHead informations (bytes J1, G1 and B3). The function monitors also byte C2 to allow unequipped VC detection.

a) Path Trace Checking (Byte J1)

This byte shall be recovered from the POH and shall be compared with the expected value of the received Trail Trace Identifier TTI, whose value is provisioned by the EMF. This comparison is used to detect a Trace Identifier Mismatch (TIM) defect following the description given in subclause 5.2.2 of ETS 300 417-4-1 [5]. If the function is in the MON state, the TIM defect is reported to the EMF.

b) Path BIP-8 Checking (Byte B3) and Path Status Evaluation (Byte G1)

The checking and the status evaluation shall follow the description given in subclause 5.2.2 of ETS 300 417-4-1 [5].

NOTE 3: In case of unidirectional transmission, the G1 byte is ignored.

c) Path Signal Label Checking (Byte C2)

Byte C2 is recovered from VC-3 POH and is used for the detection of an UNEQ defect following the description given in subclause 5.2.2 of ETS 300 417-4-1 [5]. If the function is in the MON state, the UNEQ defect is reported to the EMF.

d) Performance Monitoring

For performance monitoring, the information passed to the EMF is the 1 s count.

One second filters perform a simple integration of errored blocks by counting during a one second interval. In addition, defects are filtered by the one second filter.

This function generates the following performance parameters:

- N_EBC: Every second, the number of errored near-end blocks (N_B) within that second is counted as the Near-end Error Block Count (N_EBC). A N_B is errored if one or more BIP-8 violations are detected.
- N_DS: Every second with at least one occurrence of TIM or UNEQ defect shall be indicated as a Near-end Defect Second (N_DS).
- F_EBC: Every second, the number of errored far-end blocks (F_B) within that second is counted as the Far-end Error Block Count (F_EBC). A F_B is errored if the REI count indicates one or more errors.
- F_DS: Every second with at least one occurrence of RDI defect shall be indicated as a Far-end Defect Second (F_DS).

If the function is in the MON state, at the end of each one second interval the contents of N_EBC, N_DS, F_EBC and F_DS counters are reported to the EMF.

NOTE 4: In case of unidirectional transmission, only Near-end performance monitoring is processed.

Bytes K3 and N1 are ignored.

4.5.2 S2 Trail Termination (S2_TT)

The 500 μ s VC-2 multiframe structure defined in ITU-T Recommendation G.707 [15] shall be used. The VC-2 multiframe comprises 424 octets of payload and 4 octets of path OverHead (POH) as shown in figure 7. The VC-2 POH position is indicated on this figure.

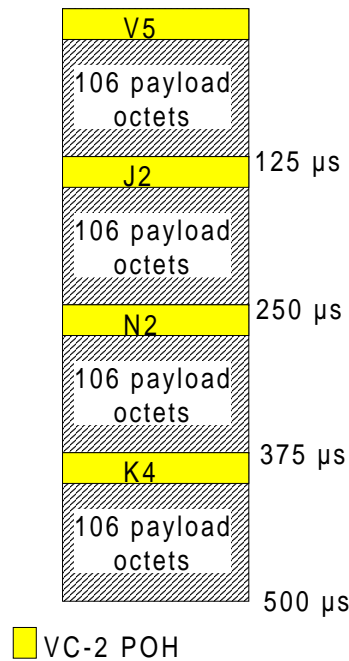

Figure 7: VC-2 multiframe structure

The content of the VC-2 POH is described in ITU-T Recommendation G.707 [15].

- Byte V5: This is the first byte in the virtual container, its location in the VC-4 frame is indicated by the associated TU-2 pointer This byte provides the functions of error checking, signal label and path status.
 - Bits 1 and 2 are used for performance monitoring Bit Interleaved Parity BIP-2 using even parity.
 - Bit 3 is a path REI used to send back to a VC-2 path originator if errors were detected by the BIP-2 by the VC-2 trail termination sink.
 - Bit 4 is a path RFI which is not used and which is therefore undefined.
 - Bits 5 through 7 convey a signal label indicating the composition or the maintenance status of the VC-2. Figure 9-7 in ITU-T Recommendation G.707 [15] provides appropriate codes for these bits.
 - Bit 8 is a path Remote Defect Indication (RDI) used to send back to a VC-2 path originator if defects were detected by the VC-2 trail termination sink.
- Byte J2 (path trace): This byte is used to transmit repetitively a PAPI so that a path receiving terminal can verify its continued connection to the intended transmitter.
- Byte K4 (APS channel + spare): Bits 1 to 4 are allocated for APS signalling for protection at the VC-2 path levels. Bits 5 to 8 are undefined.
- Byte N2 (Network operator byte): This byte is allocated to provide Tandem Connection Monitoring (TCM) function.

Table 4 indicates for each of the VC-2 POH bits/bytes if they are used in the context of the SDH network adapter and, if necessary, any setting of particular value.

NOTE 1: Some of these bits are processed by the VPME function.

Table 4: VC-2 POH

VC-2 POH bytes	Used	Particular value
V5 bits 1-2 (BIP-2)	Yes	-
V5 bit3 (REI)	Yes	-
V5 bit 4 (RFI)	No	Undefined
V5 bit 5-7 (signal label)	Yes (see VPME)	Set to "001"
V5 bit 8 (RDI)	Yes	-
J2 (Path Trace)	Yes	-
N2 (Network operator byte)	No	Undefined
K4 (APS + spare)	No	Undefined

Signal processing in the transmitter (Signal flow from e-to-f in figure 1)

Data at point e is a VC-2 with undefined POH bytes J2, K4 and V5 (except bits 5 through 7).

In the transmitter, this function generates and adds the error monitoring, status and control OverHead information (byte J2 and bits 1 to 4 and 8 of V5) to the VC-2 POH.

- a) Path Trace (Byte J2)
This byte conveys a Path Trace that is provisioned by the EMF using a format as described in subclause 6.2.1 of ETS 300 417-4-1 [5].
- b) V5 Byte
Bits 1 and 2 are used for error performance monitoring. Bit 3 is used for a Remote Error Indication (REI). Bit 4 is undefined. Bits 5 through 7 are already specified in the VPME. Bit 8 is a path Remote Defect Indication (RDI). The setting of the bits 1 through 3 and of bit 8 of this V5 byte shall be done according to the description given in subclause 6.2.1 of ETS 300 417-4-1 [5].

NOTE 2: In case of unidirectional transmission, there is no associated path termination and the REI and RDI shall be set to "0".

Bytes K4 and N2 are undefined.

Signal processing in the receiver (Signal flow from f-to-e in figure 1)

Data at point f is a VC-2 with fully defined POH.

In the receiver, this function monitors VC-2 for errors and extracts the payload independent OverHead informations (byte J2 and V5).

- a) Path Trace Checking (Byte J2)
This byte shall be recovered from the POH and shall be compared with the expected value of the received TTI, whose value is provisioned by the EMF. This comparison is used to detect a Trace Identifier Mismatch (TIM) defect following the description given in subclause 6.2.2 of ETS 300 417-4-1 [5]. If the function is in the MON state, the TIM defect is reported to the EMF.
- b) BIP-2 Checking (Bits 1 and 2 of Byte V5) and REI and RDI Checking (Bits 3 and 8 of byte V5)

The BIP-2 checking and the REI and RDI checking shall be done according to the description given in subclause 6.2.2 of ETS 300 417-4-1 [5].

NOTE 3: In case of unidirectional transmission, the REI (bit 3 of V5) and RDI (bit 8 of V5) shall be ignored.

- c) Path Signal Label Checking (Bits 5 through 7 of byte V5)
Bits 5 through 7 are recovered from VC-2 POH and are used for the detection of an UNEQ defect following the description given in subclause 6.2.2 of ETS 300 417-4-1 [5]. If the function is in the MON state, the UNEQ defect is reported to the EMF.

- d) Performance Monitoring
- e) For performance monitoring, the information passed to the EMF is the 1 second count.

One second filters perform a simple integration of errored blocks by counting during a one second interval. In addition, defects are filtered by the one second filter.

This function generates the following performance parameters:

- N_EBC: Every second, the number of errored near-end blocks (N_B) within that second is counted as the Near-end Error Block Count (N_EBC). A N_B is errored if one or more BIP-2 violations are detected.
- N_DS: Every second with at least one occurrence of TIM or UNEQ defect shall be indicated as a Near-end Defect Second (N_DS).
- F_EBC: Every second, the number of errored far-end blocks (F_B) within that second is counted as the Far-end Error Block Count (F_EBC). A F_B is errored if the REI count indicates one or more errors.
- F_DS: Every second with at least one occurrence of RDI defect shall be indicated as a Far-end Defect Second (F_DS).

If the function is in the MON state, at the end of each one second interval the contents of N_EBC, N_DS, F_EBC and F_DS counters are reported to the EMF.

NOTE 4: In case of unidirectional transmission, only Near-end performance monitoring is processed.

Bytes K4 and N2 and bit 4 of byte V5 are ignored.

4.5.3 S12 Trail Termination (S12_TT)

The 500 μ s VC-12 multiframe structure defined in ITU-T Recommendation G.707 [15] shall be used. The VC-12 multiframe comprises 136 octets of payload and 4 octets of Path OverHead (POH) as shown in figure 8. The VC-12 POH position is indicated on this figure.

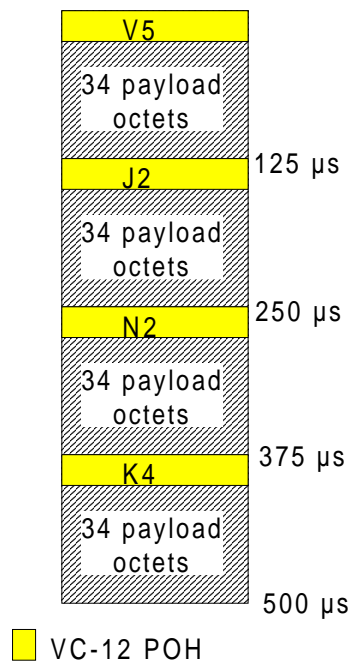

Figure 8: VC-12 multiframe structure

The content of the VC-12 POH is described in ITU-T Recommendation G.707 [15]. It is identical to the VC-2 POH described in subclause 4.5.2.

Table 5 indicates for each of the VC-12 POH bits/bytes if they are used in the context of the SDH network adapter and, if necessary, any setting of particular value.

NOTE 1: Some of these bits are processed by the VPME function.

Table 5: VC-12 POH

VC-12 POH bytes	Used	Particular value
V5 bits 1-2 (BIP-2)	Yes	-
V5 bit3 (REI)	Yes	-
V5 bit 4 (RFI)	No	Undefined
V5 bit 5-7 (signal label)	Yes (see VPME)	Set to "001"
V5 bit 8 (RDI)	Yes	-
J2 (Path Trace)	Yes	-
N2 (Network operator byte)	No	Undefined
K4 (APS + spare)	No	Undefined

Signal processing in the transmitter (Signal flow from e-to-f in figure 1)

Data at point e is a VC-12 with undefined POH bytes J2, K4 and V5 (except bits 5 through 7).

In the transmitter, this function generates and adds the error monitoring, status and control OverHead information (byte J2 and bits 1 to 4 and 8 of V5) to the VC-12 POH.

a) Path Trace (Byte J2)

This byte conveys a Path Trace that is provisioned by the EMF using a format as described in subclause 7.2.1 of ETS 300 417-4-1 [5].

b) V5 Byte

Bits 1 and 2 are used for error performance monitoring. Bit 3 is used for a Remote Error Indication (REI). Bit 4 is undefined. Bits 5 through 7 are already specified in the VPME. Bit 8 is a path Remote Defect Indication RDI. The setting of the bits 1 through 3 and of bit 8 of this V5 byte shall be done according to the description given in subclause 7.2.1 of ETS 300 417-4-1 [5].

NOTE 2: In case of unidirectional transmission, there is no associated path termination and the REI and RDI shall be set to "0".

Bytes K4 and N2 are undefined.

Signal processing in the receiver (Signal flow from f-to-e in figure 1)

Data at point f is a VC-12 with fully defined POH.

In the receiver, this function monitors VC-12 for errors and extracts the payload independent OverHead informations (byte J2 and V5).

a) Path Trace Checking (Byte J2)

This byte shall be recovered from the POH and shall be compared with the expected value of the received Trail Trace Identifier (TTI), whose value is provisioned by the EMF. This comparison is used to detect a Trace Identifier Mismatch (TIM) defect following the description given in subclause 7.2.2 of ETS 300 417-4-1 [5]. If the function is in the MON state, the TIM defect is reported to the EMF.

b) BIP-2 Checking (Bits 1 and 2 of Byte V5) and REI and RDI Checking (Bits 3 and 8 of byte V5)

The BIP-2 checking and the REI and RDI checking shall be done according to the description given in subclause 7.2.2 of ETS 300 417-4-1 [5].

NOTE 3: In case of unidirectional transmission, the REI (bit 3 of V5) and RDI (bit 8 of V5) shall be ignored.

c) Path Signal Label Checking (Bits 5 through 7 of byte V5)

Bits 5 through 7 are recovered from VC-12 POH and are used for the detection of an UNEQ defect following the description given in subclause 7.2.2 of ETS 300 417-4-1 [5]. If the function is in the MON state, the UNEQ defect is reported to the EMF.

d) Performance Monitoring

e) For performance monitoring, the information passed to the EMF is the 1 second count.

One second filters perform a simple integration of errored blocks by counting during a one second interval. In addition, defects are filtered by the one second filter.

This function generates the following performance parameters:

- N_EBC: Every second, the number of errored near-end blocks (N_B) within that second is counted as the Near-end Error Block Count (N_EBC). A N_B is errored if one or more BIP-2 violations are detected.
- N_DS: Every second with at least one occurrence of TIM or UNEQ defect shall be indicated as a Near-end Defect Second (N_DS).
- F_EBC: Every second, the number of errored far-end blocks (F_B) within that second is counted as the Far-end Error Block Count (F_EBC). A F_B is errored if the REI count indicates one or more errors.
- F_DS: Every second with at least one occurrence of RDI defect shall be indicated as a Far-end Defect Second (F_DS).

If the function is in the MON state, at the end of each one second interval the contents of N_EBC, N_DS, F_EBC and F_DS counters are reported to the EMF.

NOTE 4: In case of unidirectional transmission, only Near-end performance monitoring is processed.

Bytes K4 and N2 and bit 4 of byte V5 are ignored.

4.5.4 S11 Trail Termination (S11_TT)

The 500 μ s VC-11 multiframe structure defined in ITU-T Recommendation G.707 [15] shall be used. The VC-11 multiframe comprises 100 octets of payload and 4 octets of Path OverHead (POH) as shown in figure 9. The VC-11 POH position is indicated on this figure.

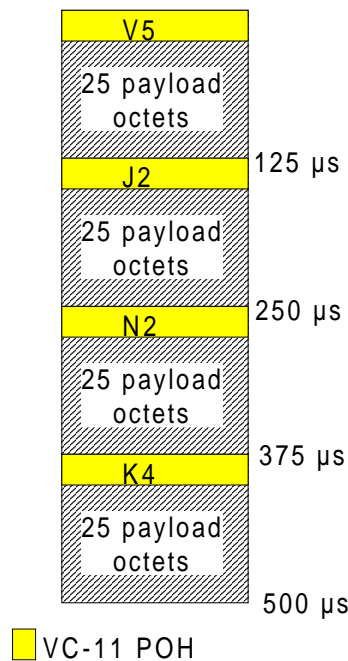

Figure 9: VC-11 multiframe structure

The content of the VC-11 POH is described in ITU-T Recommendation G.707 [15]. It is identical to the VC-2 POH described in subclause 4.5.2.

Table 6 indicates for each of the VC-11 POH bits/bytes if they are used in the context of the SDH network adapter and, if necessary, any setting of particular value.

NOTE 5: Some of these bits are processed by the VPME function.

Table 6: VC-11 POH

VC-11 POH bytes	Used	Particular value
V5 bits 1-2 (BIP-2)	Yes	-
V5 bit3 (REI)	Yes	-
V5 bit 4 (RFI)	No	Undefined
V5 bit 5-7 (signal label)	Yes (see VPME)	Set to "001"
V5 bit 8 (RDI)	Yes	-
J2 (Path Trace)	Yes	-
N2 (Network operator byte)	No	Undefined
K4 (APS + spare)	No	Undefined

Signal processing in the transmitter (Signal flow from e-to-f in figure 1)

Data at point e is a VC-11 with undefined POH bytes J2, K4 and V5 (except bits 5 through 7).

In the transmitter, this function generates and adds the error monitoring, status and control OverHead information (byte J2 and bits 1 to 4 and 8 of V5) to the VC-11 POH.

a) Path Trace (Byte J2)

This byte conveys a PT that is provisioned by the EMF using a format as described in subclause F.2.1 of ETS 300 417-4-1 [5].

b) V5 Byte

c) Bits 1 and 2 are used for error performance monitoring. Bit 3 is used for a REI. Bit 4 is undefined. Bits 5 through 7 are already specified in the VPME. Bit 8 is a path RDI. The setting of the bits 1 through 3 and of bit 8 of this V5 byte shall be done according to the description given in subclause F.2.1 of ETS 300 417-4-1 [5].

NOTE 6: In case of unidirectional transmission, there is no associated path termination and the REI and RDI shall be set to "0".

Bytes K4 and N2 are undefined.

Signal processing in the receiver (Signal flow from f-to-e in figure 1)

Data at point f is a VC-11 with fully defined POH.

In the receiver, this function monitors VC-11 for errors and extracts the payload independent OverHead informations (byte J2 and V5).

a) Path Trace Checking (Byte J2)

This byte shall be recovered from the POH and shall be compared with the expected value of the received TTI, whose value is provisioned by the EMF. This comparison is used to detect a Trace Identifier Mismatch (TIM) defect following the description given in subclause F.2.2 of ETS 300 417-4-1 [5]. If the function is in the MON state, the TIM defect is reported to the EMF.

b) BIP-2 Checking (Bits 1 and 2 of Byte V5) and REI and RDI Checking (Bits 3 and 8 of byte V5)

The BIP-2 checking and the REI and RDI checking shall be done according to the description given in subclause F.2.2 of ETS 300 417-4-1 [5].

NOTE 7: In case of unidirectional transmission, the REI (bit 3 of V5) and RDI (bit 8 of V5) shall be ignored.

- c) Path Signal Label Checking (Bits 5 through 7 of byte V5)

Bits 5 through 7 are recovered from VC-11 POH and are used for the detection of an UNEQ defect following the description given in subclause F.2.2 of ETS 300 417-4-1 [5]. If the function is in the MON state, the UNEQ defect is reported to the EMF.

- d) Performance Monitoring

- e) For performance monitoring, the information passed to the EMF is the 1 s count.

One second filters perform a simple integration of errored blocks by counting during a one second interval. In addition, defects are filtered by the one second filter.

This function generates the following performance parameters:

- N_EBC: Every second, the number of errored near-end blocks (N_B) within that second is counted as the Near-end Error Block Count (N_EBC). A N_B is errored if one or more BIP-2 violations are detected.
- N_DS: Every second with at least one occurrence of TIM or UNEQ defect shall be indicated as a Near-end Defect Second (N_DS).
- F_EBC: Every second, the number of errored far-end blocks (F_B) within that second is counted as the Far-end Error Block Count (F_EBC). A F_B is errored if the REI count indicates one or more errors.
- F_DS: Every second with at least one occurrence of RDI defect shall be indicated as a Far-end Defect Second (F_DS).

If the function is in the MON state, at the end of each one second interval the contents of N_EBC, N_DS, F_EBC and F_DS counters are reported to the EMF.

NOTE 8: In case of unidirectional transmission, only Near-end performance monitoring is processed.

Bytes K4 and N2 and bit 4 of byte V5 are ignored.

4.6 Higher Order Assembler (HOA)

The HOA function is responsible for adaptation of the LOVC into the corresponding HOVC (VC-4) including VC-4 POH generation and interpretation.

HOA is a compound function which consists of two functional blocks reflecting the description of the functional structure of SDH equipment given in ETS 300 417-4-1 [5] (see figure 10).

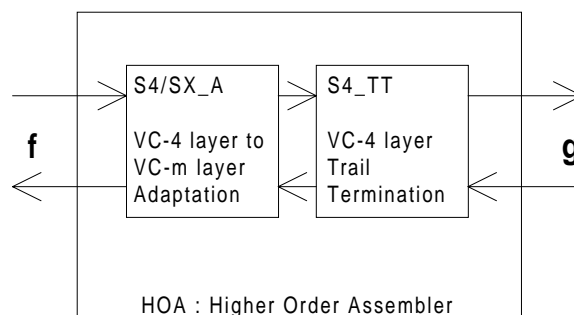

Figure 10: HOA constituents

Based on ETS 300 147 [1], the ETSI multiplexing structure of LOVCs into VC-4 is shown in figure 11. VC-4 can be used to transport VC-11s, VC-12s, VC-2s or VC-3s.

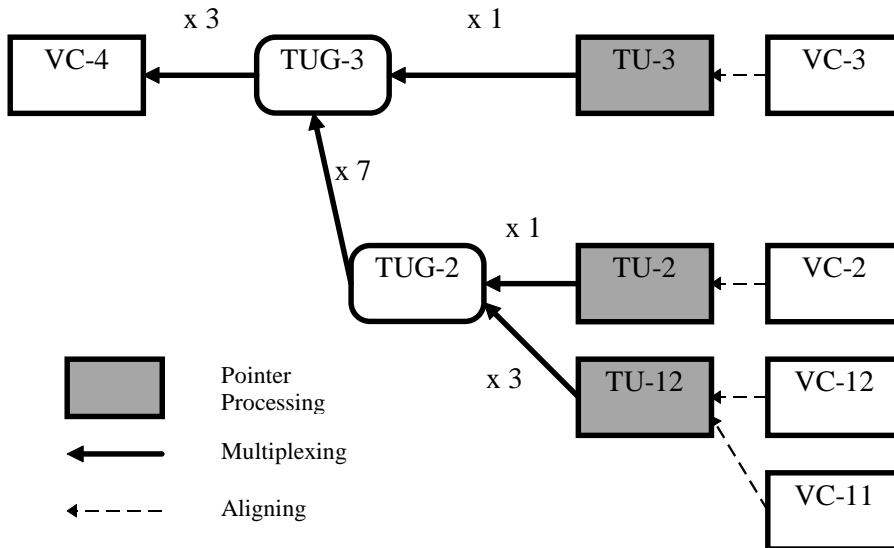

Figure 11: ETSI multiplexing structure of LOVCs into VC-4

Because each of the LOVCs is a frame synchronous structure, whose frame phase is uncorrelated with the supporting VC-4, the information of this phase alignment be transferred together with the associated LOVC in the VC-4 payload. The frame alignment between LOVCs and VC-4 is also functional part of the HOA. Since the frame alignment is dynamic it is not only able to accommodate for differences in the phases between VC-4 and LOVCs but can correct for different frame rates as well.

The frame alignment information is the offset in bytes between the LOVC frame and the corresponding VC-4 frame. This offset is coded as binary integer and called tributary unit pointer. The combination of a pointer value and the corresponding VC-m is called a Tributary Unit (TU-m).

Several TUs are combined into a Tributary Unit Group (TUG). Two types of TUG are defined: TUG-2 and TUG-3. TUG-2 is used to transport up to three TU-12 or one TU-2. A VC-11 is transported into a TU-12.

One TUG-3 can contain one TU-3 or up to 7 TUG-2, where each TUG-2 may possess a different payload structure.

A VC-4 can accommodate up to 3 TUG-3, where each TUG-3 may possess a different payload structure.

The employed frame structures, pointers and usage of pointers are defined in ITU-T Recommendation G.707 [15]. TU-3, TU-2 and TU-12 numbering scheme within the VC-4 and the corresponding time slot allocation into the VC-4 are described in figures 7-10 of ITU-T Recommendation G.707 [15]. Unused frame positions are fixed stuff.

NOTE 9: The use of more than one LOVC is optional.

These two functional blocks are also responsible for the VC-4 POH generation and interpretation. The VC-4 POH is described in subclause 4.7.

Table 7 indicates for each VC-4 POH byte if it is used by HOA in the context of the SDH network adapter and, if necessary, any setting of particular value.

NOTE 10: One part of the VC-4 POH is processed by S4/SX_A, the other by S4_TT.

Table 7: VC-4 POH

VC-4 POH bytes	Used	Particular value
J1 - Path Trace	Yes (see S4_TT)	-
B3 - BIP-8	Yes (see S4_TT)	-
C2 - Signal Label	Yes (see S4/SX_A)	Set to "02H"
G1 - REI + RDI + spare	Yes (see S4_TT)	-
F2 - Path user channel	No	Undefined
H4 - Position indicator	Note (see S4/SX_A)	Note
F3 - Path user channel	No	Undefined
K3 - APS + spare	No	Undefined
N1 - Network operator byte	No	Undefined
NOTE:	H4 is processed in S4/SX_A block. Its content depends on the VC-4 payload structure. When the VC-4 payload contains VC-3 only, the H4 byte is undefined. When the VC-4 payload contains one or more VC-11, VC-12 or VC-2, the H4 byte contains a multiframe indicator identifying frames containing the TU-2/TU-12 pointers as described in subclause 8.3.8 of ITU-T Recommendation G.707 [15].	

Signal processing in the transmitter (Signal flow from f-to-g in figure 1)

Data at f is a LOVC or a set of LOVCs coming from Sm_TT.

S4/SX_A:

This function generates the LOVC pointers depending on the differential phase differences between HOVC and LOVCs. Pointer and LOVC are combined into TU-3 for VC-3 input or TU-2/TU-12 for VC-2/VC-1 input.

This function multiplexes the resulting TUs into TUG-2 if the incoming signal is a VC-1 or VC-2. Up to 7 TUG-2 shall be multiplexed into one TUG-3. If the incoming signal is a VC-3, one TU-3 is mapped directly into TUG-3. Up to 3 resulting TUG-3s shall be multiplexed into one C-4.

NOTE 11: According to ETS 300 147 [1], a VC-11 is transported by a TU-12.

Two payload specific bytes are also added to the VC-4 POH:

- C2 byte: this byte conveys the signal label and shall be set to "02H" corresponding to "TUG structure" as described in table 7 of ITU-T Recommendation G.707 [15].
- H4 byte: if the TUG structure consists of TU-3s only, the value of H4 is undefined. Otherwise, this byte convey a multiframe indicator as specified in subclause 4.3.5.1 of ETS 300 417-4-1 [5].

The adaptation process and the addition of the payload specific bytes shall follow the description given in ETS 300 417-4-1 [5], subclause 4.3.5.

S4_TT:

This function is described in subclause 4.7 of this ETS.

The VC-4 output is transferred to TTF.

Signal processing in the receiver (Signal flow from g-to-f in figure 1)

The HOA receives VC-4 as input signal from TTF.

S4_TT:

This function is described in subclause 4.7 of this ETS.

S4/SX_A:

This function extracts bytes H4 and C2 from the VC-4 POH and monitors them.

Afterwards this function performs the demultiplexing of the VC-4 payload. The TUG-3s are extracted from VC-4. If one TUG-3 contains a TU-3, it is extracted from TUG-3. If there is no TU-3 within the TUG-3, up to seven TUG-2 are contained within the TUG-3. These are extracted from TUG-3. Each of these TUG-2s is split up into TU-2s or TU-12s.

This function performs also the TU pointers interpretation.

Based on the incoming reference clock and the actual TU pointer value the gapped LOVC clock is regenerated.

The recovered VC-m (m = 11, 12, 2, 3) and its gapped clock are transferred to Sm_TT for further processing.

The demultiplexing process and the monitoring of the payload specific bytes shall follow the description given in ETS 300 417-4-1 [5], subclause 4.3.6.

4.7 S4 Trail Termination (S4_TT)

The VC-4 frame structure defined in ITU-T Recommendation G.707 [15] shall be used. The VC-4 frame comprises 2 340 octets of payload and 9 octets of path OverHead (POH) as shown in figure 12. The VC-4 POH is located in the first column of the 9-rows by 261-columns VC-4 structure.

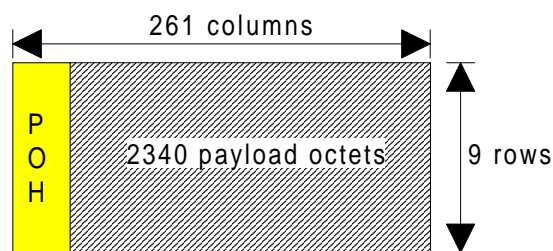

Figure 12: VC-4 frame structure

The content of the VC-4 POH is described in ITU-T Recommendation G.707 [15] and in documents ETS 300 417-1-1 [2] and ETS 300 417-4-1 [5].

- Byte J1 (path trace): This is the first byte in the virtual container, its location in the STM-1 frame is indicated by the associated AU-4 pointer. This byte is used to transmit repetitively a PAPI so that a path receiving terminal can verify its continued connection to the intended transmitter. The value of this byte shall follow the recommendations given in subclause 7.1 of ETS 300 417-1-1 [2].
- Byte B3 (BIP-8): This byte is used for bit error monitoring. It uses a Bit Interleaved Parity BIP-8 using even parity as described in subclause 9.3.1.2 of ITU-T Recommendation G.707 [15].
- Byte C2 (signal label): This byte indicates the composition or the maintenance status of the VC-4. Table in ITU-T Recommendation G.707 [15] provides appropriate codes for this byte.
- Byte G1 (Path status): This byte is allocated to send back to a VC-4 trail termination source the path status and performance as detected by a trail termination sink using Remote Defect Indication (RDI) and Remote Error Indication (REI). The allocation of the bits shall be done in accordance with the description given in ETS 300 417-4-1 [5].
- Bytes F2 and F3 (Path user channels): These bytes are allocated for user communication purposes between path elements and are payload dependent.
- Byte H4 (position indicator): This byte is payload specific.
- Byte K3 (APS channel + spare): Bits 1 to 4 are allocated for APS signalling for protection at the VC-4 path levels. Bits 5 to 8 are undefined.

- Byte N1 (Network operator byte): This byte is allocated to provide Tandem Connection Monitoring (TCM) function.

Table 8 indicates for each of the VC-4 POH bytes if they are used in the context of the SDH network adapter and, if necessary, any setting of particular value.

NOTE 1: Some of these bytes are processed by the VPME function.

Table 8: VC-4 POH

VC-4 POH bytes	Used	Particular value
J1 - Path Trace	Yes	-
B3 - BIP-8	Yes	-
C2 - Signal Label	Yes (see VPME)	Set to "00010011"
G1 - REI + RDI + spare	Yes	-
F2 - Path user channel	No (see VPME)	Undefined
H4 - Position indicator	No (see VPME)	Undefined
F3 - Path user channel	No (see VPME)	Undefined
K3 - APS + spare	No	Undefined
N1 - Network operator byte	No	Undefined

Signal processing in the transmitter (Signal flow from e-to-g in figure 1)

Data at point e is a VC-4 with undefined POH bytes J1, B3 and G1.

In the transmitter, this function generates and adds the error monitoring, status and control OverHead information (bytes J1, G1 and B3) to the VC-4 POH.

a) Path Trace (Byte J1)

This byte conveys a Path Trace that is provisioned by the EMF using a format as described in subclause 4.2.1 of ETS 300 417-4-1 [5].

b) BIP-8 Calculation (Byte B3)

The calculation shall be done according to the description given in subclause 4.2.1 of ETS 300 417-4-1 [5].

c) Path Status (Byte G1)

- d) Bits 1 through 4 convey the count of blocks that have been detected in error by the trail termination sink using the information of Byte B3 for an REI. Bit 5 is used to indicate a path RDI. Bits 6 through 8 are undefined. The values of these bits shall be set according to subclause 4.2.1 of ETS 300 417-4-1 [5].

NOTE 2: In case of unidirectional transmission, there is no associated path termination and the byte G1 shall be set to a logical "0".

Bytes K3 and N1 are undefined.

Signal processing in the receiver (Signal flow from g-to-e in figure 1)

Data at point g is a VC-4 with fully defined POH.

In the receiver, this function monitors VC-4 for errors and extracts the payload independant OverHead informations (bytes J1, G1 and B3). The function also monitors byte C2 to allow unequipped VC detection.

a) Path Trace Checking (Byte J1)

This byte shall be recovered from the POH and shall be compared with the expected value of the received Trail Trace Identifier TTI, whose value is provisioned by the EMF. This comparison is used to detect a Trace Identifier Mismatch (TIM) defect following the description given in subclause 4.2.2 of ETS 300 417-4-1 [5]. If the function is in the MON state, the TIM defect is reported to the EMF.

b) Path BIP-8 Checking (Byte B3) and Path Status Evaluation (Byte G1)

The checking and the status evaluation shall follow the description given in subclause 4.2.2 of ETS 300 417-4-1 [5].

NOTE 3: In case of unidirectional transmission, the G1 byte is ignored.

c) Path Signal Label Checking (Byte C2)

Byte C2 is recovered from VC-4 POH and is used for the detection of an UNEQ defect following the description given in subclause 4.2.2 of ETS 300 417-4-1 [5]. If the function is in the MON state, the UNEQ defect is reported to the EMF.

d) Performance Monitoring

e) For performance monitoring, the information passed to the EMF is the 1 second count.

One second filters perform a simple integration of errored blocks by counting during a one second interval. In addition, defects are filtered by the one second filter.

This function generates the following performance parameters:

- N_EBC: Every second, the number of errored near-end blocks (N_B) within that second is counted as the Near-end Error Block Count (N_EBC). A N_B is errored if one or more BIP-8 violations are detected.
- N_DS: Every second with at least one occurrence of TIM or UNEQ defect shall be indicated as a Near-end Defect Second (N_DS).
- F_EBC: Every second, the number of errored far-end blocks (F_B) within that second is counted as the Far-end Error Block Count (F_EBC). A F_B is errored if the REI count indicates one or more errors.
- F_DS: Every second with at least one occurrence of RDI defect shall be indicated as a Far-end Defect Second (F_DS).

If the function is in the MON state, at the end of each one second interval the contents of N_EBC, N_DS, F_EBC and F_DS counters are reported to the EMF.

NOTE 4: In case of unidirectional transmission, only Near-end performance monitoring is processed.

Bytes K3 and N1 are ignored.

4.8 Transport Terminal Function (TTF)

The AU-4 pointer is processed respectively evaluated to indicate the phase of the first byte of the VC-4 POH relative to the first byte of the STM-1 SOH. Additionally, this function acts as a source and sink for the MSOH and the RSOH information of an STM-1 frame. The STM-1 frame is scrambled/descrambled and the appropriate signal at the physical interface is created in the transmitter respectively converted into an internal logical signal in the receiver taking into account the network data rate of 155 Mbit/s. The frame structure for such a signal is shown in figure 13.

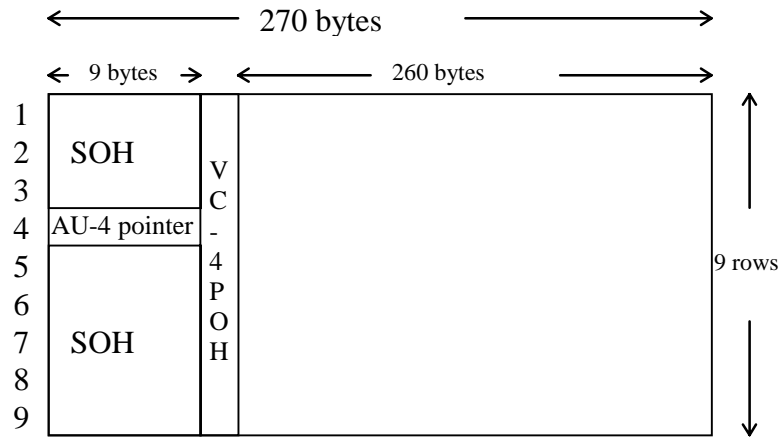

Figure 13: Frame structure of an STM-1 frame

The contents of the SOH is shown in detail in figure 14. The SOH is split up in two parts, the Regenerator Section OverHead (RSOH) and the Multiplexer Section OverHead (MSOH). All unmarked bytes are reserved for future standardization or for national use or are media dependent bytes.

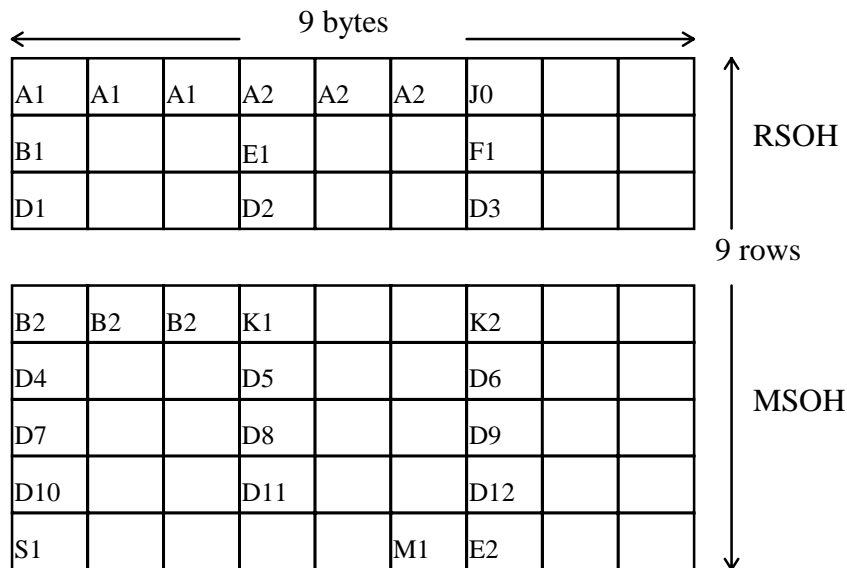

Figure 14: SOH bytes for STM-1

TTF is a compound function which consists of a set of blocks or functions specified in SDH equipment standards ETS 300 417-2- [3] and ETS 300 417-3-1 [4]. These components are shown in figure 15.

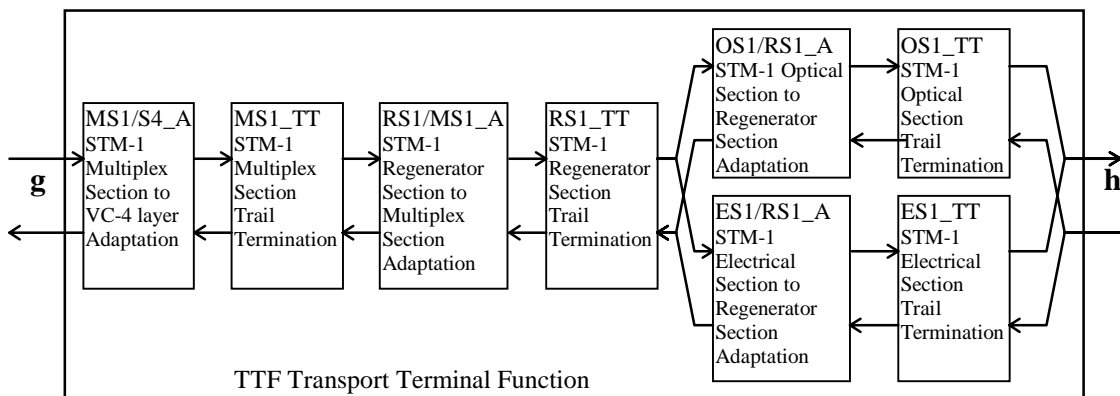

Figure 15: Blocks of the compound function "Transport Terminal Function (TTF)"

To prevent alarms being raised and failures being reported during path provision, the functions MS1_TT, RS1_TT, OS1-TT and ES1_TTT shall have the ability to enable or disable fault cause declaration. The functions shall be either "monitored" (MON) or "not monitored" (NMON). The state MON or NMON is provided by the equipment manager to the appropriate functions via the EMF function.

Some of the SOH bytes shown in figure 14 are not used inside the NA. Therefore, these bytes are undefined and their contents is ignored in the receiver. This holds for the following bytes:

- Orderwire RSOH (Byte E1): This byte may be used to provide orderwire channels for voice communication. Byte E1 is part of the RSOH and may be accessed at regenerators.
- User Channel (Byte F1): This byte is reserved for user purposes.
- Data Communication Channel DCC RSOH (Bytes D1 - D3): A 192 kbit/s channel can be implemented using bytes D1, D2 and D3 as a DCC in a Regenerator Section.
- Automatic Protection Switching (APS) Channel (Byte K1 and bits 1 to 5 of byte K2): Byte K1 and bits 1 to 5 of byte K2 are allocated for APS signalling for the protection of the multiplex section. The setting depends on the chosen maintenance strategy of the network operator.
- Data Communication Channel DCC MSOH (Bytes D4 - D12): A 576 kbit/s channel can be implemented using bytes D4 to D12 as a DCC in a Multiplex Section.
- Orderwire MSOH (Byte E2): This byte may be used to provide orderwire channels for voice communication. Byte E2 is part of the MSOH and may be accessed at multiplex section terminations.

Signal processing in the transmitter (Signal flow from g-to-h in figure 1)

Data at point g is a signal possessing a frame structure as shown in figure 13 with SOH and AU-4 pointer undefined.

STM-1 Multiplex section to VC-4 layer Adaptation

In the transmitter, this function provides adaptation of VC-4 into AU-4 and pointer generation together with the setting of some information of the MSOH.

- a) AU-4 Pointer (Bytes H1, H2 and H3)
 The AU-4 pointer is contained in bytes H1 and H2 as shown in 16. The pointer is aligned in the STM-1 payload in a fixed position relative to the STM-1 frame and is pointing to the beginning of the VC-4 frame within the STM-1. If there is a frequency offset between the frame rate of the Administrative Unit Group and that of the VC-4, then the pointer value will be incremented or decremented as needed. Consecutive pointer operations be separated by at least three frames in which the pointer value remains constant. Upon a positive justification, three stuff bytes shall be transmitted in the three bytes following the third H3 byte. Upon a negative justification, three data bytes are to be transmitted in the three H3 bytes.

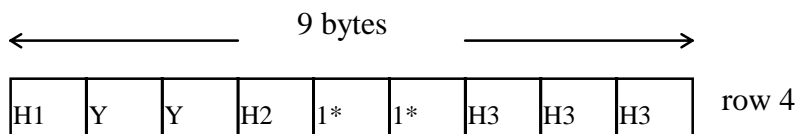

1*: All 1s byte

Y: 10011011

Figure 16: AU-4 pointers

The function shall generate the pointer value as described in subclause 5.3.1 of ETS 300 417-3-1 [4].

- b) Synchronization Status (Bits 5 to 8 of Byte S1)
Bits 1 to 4 of byte S1 are undefined. Bits 5 to 8 are used for the signalling of the SDH synchronization quality level. Their values shall be set to "0000" according to table 5 of ITU-T Recommendation G.707 [15] which signals that the quality level is unknown.

STM-1 Multiplex Section Trail Termination

In the transmitter, this function generates and adds the error monitoring, status and control OverHead information to the STM-1 MSOH.

- c) Multiplex Section - Remote Error Indication (MS-REI) (Byte M1)
If an errored block has been detected by the BIP-24 in the receiving direction, this byte shall be used to convey the number of interleaved bit blocks that have been detected in error by the BIP-24 in the range of [0, 24] using the format as described in subclause 5.2.1 of ETS 300 417-3-1 [4].

NOTE1: In case of unidirectional transmission, there is no receiving path termination and the MS-REI shall be set to a logical "0".

- d) Multiplex Section - Remote Defect Indication (MS-RDI) (Bits 6 to 8 of Byte K2)
The defect indication shall be done according to the description given in subclause 5.2.1 of ETS 300 417-3-1 [4].

NOTE 2: In case of unidirectional transmission, there is no receiving path termination and the MS-RDI shall be set to a logical "0".

- e) BIP-24 Calculation (Bytes B2)

The calculation shall be done according to the description given in subclause 5.2.1 of ETS 300 417-3-1 [4].

STM-1 Regenerator Section to Multiplex Section Adaptation

In the transmitter, this function provides adaptation of the multiplex section into the STM-1 regenerator section.

This function multiplexes the MSOH, the AU-4 pointer and the VC-4 data (2 403 bytes/frame) into the STM-1 frame according to the description given in subclause 4.3.1 of ETS 300 417-3-1 [4].

STM-1 Regenerator Section Trail Termination

In the transmitter, this function completes the STM-1 signal by adding the frame alignment information, the section trace identifier and the parity control byte to the STM-1 RSOH and scrambles the signal.

- f) Regenerator Section Trace (Byte J0)

This byte is used to transmit repetitively an API which is carried by a TTI so that a section receiver can verify its continued connection to the intended transmitter in order to make sure that data is not delivered to the wrong destination. For this check a 16 byte frame is used transmitted in byte J0 of successive STM-1 frames. The value of this byte shall be set in accordance with the description given in subclause 7.1 of ETS 300 417-1-1 [2] and is provisioned by the EMF.

- g) BIP-8 Calculation (Byte B1)

The calculation shall be done according to the description given in subclause 4.2.1 of ETS 300 417-3-1 [4].

- h) Frame Alignment (Bytes A1 and A2)

The function shall insert the frame alignment signal A1A1A1A2A2A2 as described in subclause 4.2.1 of ETS 300 417-3-1 [4].

i) Scrambling

In order to prevent long sequences of logical "0"s or "1"s, the content of every STM-1 frame excluding the first row of the STM-1 SOH is scrambled by using a generating polynomial $X^7 + X^6 + 1$. The operation of the scrambler shall be in accordance with the description in subclause 4.2.1 of ETS 300 417-3-1 [4].

STM-1 Optical Section to Regenerator Section Adaptation

In the transmitter, this function provides the adaptation of the STM-1 signal into the optical physical section according to the description given in subclause 4.3.1 of ETS 300 417-2-1 [3].

STM-1 Electrical Section to Regenerator Section Adaptation

In the transmitter, this function provides the CMI encoding of the STM-1 signal. A description of this code is given in annex F. The CMI encoding process shall follow the description given in subclause 8.3.1 of ETS 300 417-2-1 [3].

STM-1 Optical Section Trail Termination

In the transmitter, this function generates the optical STM-1 signal for the transmission over optical cable. The function shall generate the optical signal according to the description given in subclause 4.2.1 of ETS 300 417-2-1 [3].

STM-1 Electrical Section Trail Termination

In the transmitter, this function generates the electrical STM-1 signal for the transmission over the electrical cable following the description given in subclause 8.2.1 of ETS 300 417-2-1 [3].

Signal processing in the receiver (Signal flow from h-to-g in figure 1)

Data at point h is an electrical or an optical STM-1 signal possessing a bit rate of 155 520 kbit/s.

STM-1 Electrical Section Trail Termination

In the receiver, this function recovers the electrical STM-1 signal transmitted over electrical cable following the description given in subclause 8.2.2 of ETS 300 417-2-1 [3].

A Loss Of Signal (LOS) defect shall be detected according to subclause 8.2.1.6 of ETS 300 417-1-1 [2] for a 155 520 kbit/s signal. In the event of LOS defect, an all-ONE's (AIS) DATA signal - complying to the frequency limits of this interface - shall be applied at reference point g accompanied by a suitable reference timing signal within 250 μ s. Upon termination of LOS, the all-ONE's signal shall be terminated within 250 μ s. If the function is in the MON state, the LOS defect is reported to the EMF.

Performance Monitoring:

For performance monitoring, the information passed to the EMF is the 1 s count. Defects are filtered by the one second filter.

This function generates the following performance parameters:

- N_DS: Every second with at least one occurrence of LOS defect shall be indicated as a Near-end Defect Second (N_DS).

If the function is in the MON state, at the end of each one second interval the contents of the N_DS counter is reported to the EMF.

STM-1 Optical Section Trail Termination

In the receiver, this function recovers the optical STM-1 signal transmitted over the optical cable following the description given in subclause 4.2.2 of ETS 300 417-2-1 [3].

A Loss Of Signal (LOS) defect shall be detected according to subclause 8.2.1.6 of ETS 300 417-1-1 [2] for a 155 520 kbit/s signal. In the event of LOS defect, an all-ONE's (AIS) DATA signal - complying to the frequency limits of this interface - shall be applied at reference point g accompanied by a suitable reference timing signal within 250 μ s. Upon termination of LOS, the all_ONE's signal shall be terminated within 250 μ s. If the function is in the MON state, the LOS defect is reported to the EMF.

Performance Monitoring:

For performance monitoring, the information passed to the EMF is the 1 s count. Defects are filtered by the one second filter.

This function generates the following performance parameters:

- N_DS: Every second with at least one occurrence of LOS defect shall be indicated as a Near-end Defect Second (N_DS).

If the function is in the MON state, at the end of each one second interval the contents of the N_DS counter is reported to the EMF.

STM-1 Electrical Section to Regenerator Section Adaptation

In the receiver, this function recovers bit timing and frame alignment from the received signal and decodes the incoming STM-1 signal according to the description given in subclause 8.3.2 of ETS 300 417-2-1 [3].

- Frame Alignment (Bytes A1 and A2).
- This function shall perform the frame alignment of the 155 520 kbit/s signal in order to recover the frame start signal of an STM-1 frame as specified in subclause 8.3.2 of ETS 300 417-2-1 [3]. The appropriate state diagram is shown in figure 17.

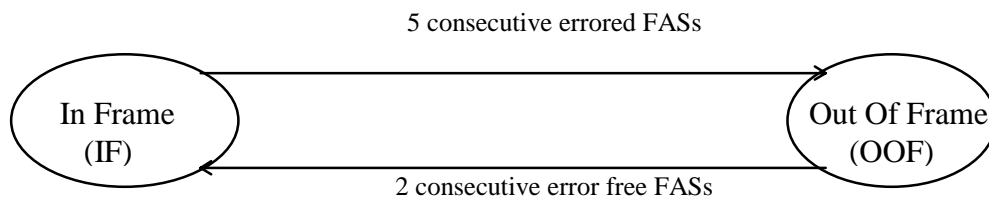

Figure 17: Frame alignment state diagram

If the frame alignment is deemed to be lost (OOF state), a LOF (Loss Of Frame) defect shall be set-up. The LOF defect shall be cleared when the frame alignment is deemed to have been recovered (IF state). The criteria for the declaration and the clearance of the LOF defect are described in subclause 8.3.2 of ETS 300 417-2-1 [3]. On declaration of LOF, the function shall output an all-ONEs (AIS) signal within 250 μ s. On clearing of LOF, the function shall output normal data within 250 μ s. If the function is in the MON state, the LOF defect is reported to the EMF.

Performance Monitoring:

For performance monitoring, the information passed to the EMF is the 1 second count. Defects are filtered by the one second filter.

This function generates the following performance parameters:

N_DS: Every second with at least one occurrence of LOF defect shall be indicated as a Near-end Defect Second (N_DS).

At the end of each one second interval the contents of the N_DS counter is reported to the EMF.

STM-1 Optical Section to Regenerator Section Adaptation

In the receiver, this function regenerates the received signal and recovers bit timing and frame alignment according to the description given in subclause 4.3.2 of ETS 300 417-2-1 [3].

- a) Frame Alignment (Bytes A1 and A2)
- b) This function shall perform the frame alignment of the 155 520 kbit/s signal in order to recover the frame start signal of an STM-1 frame as specified in subclause 4.3.2 of ETS 300 417-2-1 [3]. The appropriate state diagram is shown in figure 18.

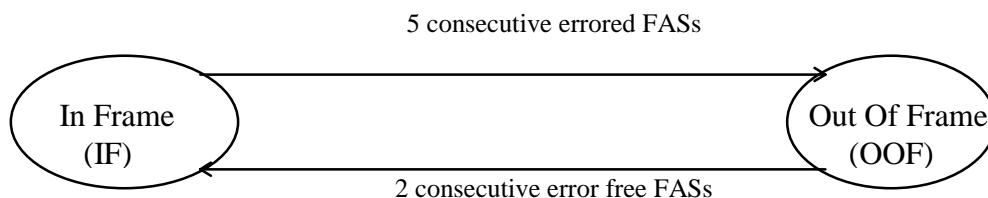

Figure 18: Frame alignment state diagram

If the frame alignment is deemed to be lost (OOF state), a LOF (Loss Of Frame) defect shall be set-up. The LOF defect shall be cleared when the frame alignment is deemed to have been recovered (IF state). The criteria for the declaration and the clearance of the LOF defect are described in subclause 4.3.2 of ETS 300 417-2-1 [3]. On declaration of LOF, the function shall output an all-ONEs (AIS) signal within 250 μ s. On clearing of LOF, the function shall output normal data within 250 μ s. If the function is in the MON state, the LOF defect is reported to the EMF.

Performance Monitoring:

For performance monitoring, the information passed to the EMF is the 1 second count. Defects are filtered by the one second filter.

This function generates the following performance parameters:

N_DS: Every second with at least one occurrence of LOF defect shall be indicated as a Near-end Defect Second (N_DS).

At the end of each one second interval the contents of the N_DS counter is reported to the EMF.

STM-1 Regenerator Section Trail Termination

In the receiver, this function descrambles the STM-1 signal, monitors it for errors and extracts relevant OverHead information from the RSOH.

- c) Descrambling
The content of every STM-1 frame excluding the first row of the STM-1 SOH shall be descrambled in accordance with the description given in subclause 4.2.2 of ETS 300 417-3-1 [4].
- d) BIP-8 Checking (Byte B1)
The checking shall be done in accordance given with the description given in subclause 4.2.2 of ETS 300 417-3-1 [4].

e) Regenerator Section Trace (Byte J0).

This byte shall be recovered from the RSOH and shall be compared with the expected value of the received Trail Trace Identifier TTI, whose value is provisioned by the EMF. This comparison is used to detect a Trace Identifier Mismatch (TIM) defect following the description given in subclause 4.2.2 of ETS 300 417-3-1 [4]. If the function is in the MON state, the TIM defect is reported to the EMF.

Performance Monitoring:

For performance monitoring, the information passed to the EMF is the 1 second count.

One second filters perform a simple integration of errored blocks by counting during a one second interval. In addition, defects are filtered by the one second filter.

This function generates the following performance parameters:

- N_EBC: Every second, the number of errored near-end blocks (N_B) within that second is counted as the Near-end Error Block Count (N_EBC). A N_B is errored if one or more BIP-8 violations are detected.
- N_DS: Every second with at least one occurrence of TIM defect shall be indicated as a Near-end Defect Second (N_DS).

If the function is in the MON state, at the end of each one second interval the contents of N_EBC and N_DS counters are reported to the EMF.

STM-1 Regenerator Section to Multiplex Section Adaptation

In the receiver, this function provides the adaptation of the STM-1 regenerator section into the multiplex section.

This function demultiplexes the MSOH, the AU-4 pointer and the VC-4 data (2 403 bytes/frame) out of the STM-1 frame according to the description given in subclause 4.3.2 of ETS 300 417-3-1 [4].

STM-1 Multiplex Section Trail Termination

In the receiver, this function monitors the multiplex section for errors and extracts relevant OverHead information from the MSOH.

f) BIP-24 Checking (Bytes B2).

The checking shall be done following the description given in subclause 5.2.2 of ETS 300 417-3-1 [4].

g) Multiplex Section - Remote Error Indication (MS-REI) (Byte M1).

The MS-REI is recovered from byte M1 in order to enable single ended maintenance of a bi-directional multiplex section following the description given in subclause 5.2.2 of ETS 300 417-3-1 [4].

NOTE 3: In case of unidirectional transmission, the M1 byte is ignored.

h) Multiplex Section - Remote Defect Indication (MS-RDI) (Bits 6 to 8 of Byte K2)

The MS-RDI is recovered from bits 6 to 8 of the K2 byte in order to enable single ended maintenance of a multiplex section. An RDI defect shall be declared when the bit pattern "110" is observed in bits 6, 7, and 8 of byte K2 in at least five consecutive frames. The RDI defect shall be cleared when any bit pattern other than "110" in bits 6,7 and 8 of byte K2 is received in at least five consecutive frames. If the function is in the MON state, the RDI defect is reported to the EMF. These bits are also used to detect an AIS.

NOTE 4: In case of unidirectional transmission, the detection of RDI is not performed.

Performance Monitoring:

For performance monitoring, the information passed to the EMF is the 1 second count.

One second filters perform a simple integration of errored blocks by counting during a one second interval. In addition, defects are filtered by the one second filter.

This function generates the following performance parameters:

- N_EBC: Every second, the number of errored near-end blocks (N_B) within that second is counted as the Near-end Error Block Count (N_EBC). A N_B is errored if one or more BIP-24 violations are detected.
- N_DS: Every second with at least one occurrence of AIS defect shall be indicated as a Near-end Defect Second (N_DS).
- F_EBC: Every second, the number of errored far-end blocks (F_B) within that second is counted as the Far-end Error Block Count (F_EBC). A F_B is errored if the MS-REI count indicates one or more errors.
- F_DS: Every second with at least one occurrence of RDI defect shall be indicated as a Far-end Defect Second (F_DS).

If the function is in the MON state, at the end of each one second interval the contents of N_EBC, N_DS, F_EBC and F_DS counters are reported to the EMF.

NOTE 5: In case of unidirectional transmission, only Near-end performance monitoring is processed.

STM-1 Multiplex Section to VC-4 layer Adaptation

In the receiver, this function provides adaptation of AU-4 into VC-4 together with the evaluation of some information of the MSOH.

- i) Synchronization Status (Bits 5 to 8 of Byte S1)
This byte is ignored.
- j) AU-4 Pointer Processing (Bytes H1, H2 and H3)
The pointer processing algorithm shall follow the description given in subclause 5.3.2 of ETS 300 417-3-1 [4]. Two defects can be detected by the processing algorithm, a loss of pointer (LOP) and an AIS. If either of these failure conditions are detected, the function shall output an all-ONEs (AIS) signal within 250 μ s. On clearing of these defects, the AIS signal shall be removed within 250 μ s.

Performance Monitoring:

For performance monitoring, the information passed to the EMF is the 1 second count. Defects are filtered by the one second filter.

This function generates the following performance parameters:

- N_DS: Every second with at least one occurrence of LOP or AIS defect shall be indicated as a Near-end Defect Second (N_DS).

At the end of each one second interval the contents of the N_DS counter is reported to the EMF.

4.9 Equipment Management Function (EMF)

The Equipment Management Function (EMF) provides the means through which the Network Element (NE) is managed by an external manager. The EMF interacts with the other basic functions by exchanging information across the MP (Management Points) reference points. The EMF contains a number of filters that provide a data reduction mechanism on the information received across the MP reference points.

The interface between the processing in the basic functions and the Equipment Management Function is indicated by the dashed line in figure 19 and represents the MP reference points. For performance monitoring the signals passed over this interface are the 1 second Near (Far)-end Errored Block Counts (N_EBC, F_EBC) and the 1 second Near (Far)-end Defect Seconds (N_DS, F_DS). For fault management the signals passed over this interface are the fault cause signal.

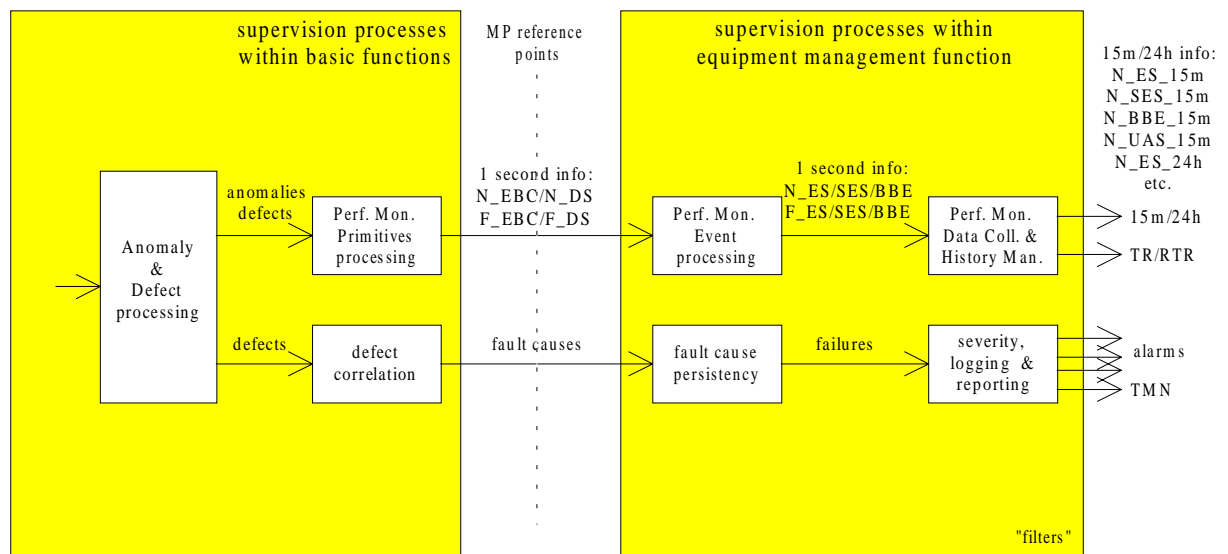

Figure 19: Supervision process within Equipment management function

The filtering functions provide a data reduction mechanism on the defect and performance monitoring primitives information presented at the MP reference points. Two types of techniques can be distinguished:

- The fault cause persistency filter will provide a persistency check on the fault causes that are reported across the MP reference points. In addition to the transmission failures listed in table 11, hardware failures with signal transfer interruption are also reported at the input of the fault cause filter for further processing.
- The performance monitoring events processing processes the information available from the one second window and reported across the MP reference points in order to derive errored seconds and severely errored seconds, and background block errors (see ITU-T Recommendation G.826 [18]).

NOTE 1: One second filters in the basic functions perform a simple integration of reported anomalies by counting during a one second interval. In addition, defects are filtered by the one second filter. At the end of each one second period, the contents of the counters may be obtained by the EMF.

The information flows described in this clause are functional. The existence of these information flows in the equipment will depend on the functionality provided by the equipment.

Table 9: Basic function associated failure list

Basic functions	Failures
RR_SPI	LOS
RR_RST	LOF TIM
RR_MST	AIS RDI
RR_MSA	AIS LOP
S3/SX_A	LOM PLM LOP AIS
SETPI	LOS
SETS	LTI
ES1_TT	LOS
ES1/RS1_A	LOF
OS1_TT	TD TF LOS
OS1/RS1_A	LOF
RS1_TT	TIM
RS1/MS1_A	
MS1_TT	AIS RDI SSF DEG
MS1/S4_A	AIS LOP
S4_TT	TIM UNEQ DEG RDI SSF
S4/SX_A	LOM PLM LOP AIS
Sm_TT (m = 11, 12, 2, 3)	TIM UNEQ DEG RDI SSF
VPME	LCD
VPE	
MAA	STATUS SNI LMC
MPI	LOS TSLE_I TSLE_O

NOTE 2: The information flow over the MP reference points that arises from anomalies and defects detected in the SDH basic functions is described in specific details for each basic function in ETS 300 417-2-1 [3], ETS 300 417-3-1 [4] and ETS 300 417-4-1 [5].

Time-stamping

Events, performance reports and registers containing event counts that require time-stamping shall be time stamped with a resolution of one second. The time shall be as indicated by the local real time clock of the NE. The required accuracy and precise details of the time-stamping of events/reports relative to Universal Time Co-ordinated (UTC) is the subject of further study (A maximum value in the range 1 to 10 s is being considered). The start of 15 minute and 24 hour counts should be accurate to within ± 10 s with respect to the NE clock.

4.9.1 Configuration

The information flow over the MP reference points that arises from configuration and provisioning data is given in table 12. The information listed under "Set" refers to configuration and provisioning data that is passed from the EMF to the other basic functions. The information listed under "Get" refers to status reports made in response to a request from the EMF for such information.

Table 10: Command, configuration information flow over MP

	GET	SET
RR_SPI		Supervision State: MON or NMON
RR_RST	- Accepted trace identifier	- Supervision State: MON or NMON - Transmitted trace identifier - Expected trace identifier - Enable/disable TIM detection - Expected trace identifier mode
RR_MST	- Enable/disable reporting of RDI - Enable/disable reporting of AIS	- Supervision State: MON or NMON - Enable/disable reporting of RDI - Enable/disable reporting of AIS
RR_MSA	- Enable/disable reporting of AIS	- Enable/disable reporting of AIS
S3/SX_A	- Enable/disable reporting of AIS	- TUG structure + sub-functions activation - Enable/disable reporting of AIS
SETPI		- Supervision State: MON or NMON
SETS	- Input Status - Input selected on A, B and C selectors - Priority to input (4) - Wait To Restore Time (per selector) (4) - Hold-off time (per selector) (4) - Operational mode selected	- Select input for selector C - Squelching on selector C - External commands (per selector) (4) - Priority to input (4) - Wait To Restore Time (per selector) (4) - Hold-off time (per selector) (4) - Select operational mode
ES1_TT		- Supervision State: MON or NMON
ES1/RS1_A		
OS1_TT		- Supervision State: MON or NMON
OS1/RS1_A		
RS1_TT	- Accepted trace identifier	- Transmitted trace identifier - Supervision State: MON or NMON - Expected trace identifier - Enable/disable TIM detection - Expected trace identifier mode
RS1/MS1_A		
MS1_TT	- Enable/disable reporting of RDI - Enable/disable reporting of SSF - Enable/disable reporting of AIS	- Supervision State: MON or NMON - Enable/disable reporting of RDI - Enable/disable reporting of SSF - Enable/disable reporting of AIS - DEG threshold (DEGTHR + M)
MS1/S4_A	- Enable/disable reporting of AIS	- Enable/disable reporting of AIS
S4_TT	- Accepted trace identifier - Enable/disable reporting of RDI - Enable/disable reporting of SSF	- Transmitted trace identifier - Supervision State: MON or NMON - Expected trace identifier - Enable/disable TIM detection - Expected trace identifier mode - DEG threshold (DEGTHR + M) - Enable/disable reporting of RDI - Enable/disable reporting of SSF
S4/SX_A	- Enable/disable reporting of AIS	- TUG structure + sub-functions activation - Enable/disable reporting of AIS

(continued)

Table 10 (concluded): Command, configuration information flow over MP

	GET	SET
Sm_TT (m = 11,12,2,3)	<ul style="list-style-type: none"> - Accepted trace identifier - Enable/disable reporting of RDI - Enable/disable reporting of SSF 	<ul style="list-style-type: none"> - Transmitted trace identifier - Supervision State: MON or NMON - Expected trace identifier - Enable/disable TIM detection - Expected trace identifier mode - DEG threshold (DEGTHR + M) - Enable/disable reporting of RDI - Enable/disable reporting of SSF
VPME	<ul style="list-style-type: none"> - Cell Discarded: Active or Not_Active - HEC correction mode: Active or Not_Active - VPI value 	<ul style="list-style-type: none"> - Supervision State: MON or NMON - Cell Discarded: Active or Not_Active - HEC correction mode: Active or Not_Active
VPE		<ul style="list-style-type: none"> - Supervision State: MON or NMON (1) - VPI value
MAA		<ul style="list-style-type: none"> - Supervision State: MON or NMON (1)
MPI	<ul style="list-style-type: none"> - Supervision State: MON or NMON - Number of packets per second - FORMAT: 188 or 204 bytes packet with 16 dummy bytes (2) 	<ul style="list-style-type: none"> - Supervision State: MON or NMON (1) - FORMAT: 188 or 204 bytes packet with 16 dummy bytes(2)
NOTE 1:	For a given MPEG interface, MPI and associated MAA and VPE are in the same state.	
NOTE 2:	This status is only relevant for the selection of the transmission format (188 bytes or 204 with 16 dummy bytes) to be used at an output SSI or SPI interface for the delivery of MPEG2-TS packets.	
NOTE 3:	The information flow over the MP reference points that arises from configuration and provisioning data is described in specific details for each SDH basic function in ETS 300 417-2-1 [3], ETS 300 417-3-1 [4] and ETS 300 417-4-1 [5].	
NOTE 4:	These commands are applicable for selectors A and B.	

4.9.2 Fault (maintenance) management

Fault cause persistency filter

The Equipment Management Function within the Network Element performs a persistency check on the fault causes before it declares a fault cause a failure. A transmission failure shall be declared if the fault cause persists continuously for $2,5 \pm 0,5$ s. The failure shall be cleared if the fault cause is absent continuously for $10 \pm 0,5$ s. Transmission failures associated with the basic functions are listed in table 11.

Alarm history management

Alarm history management is concerned with the recording of alarms. Historical data shall be stored in registers in the NE. Each register contains all the parameters of an alarm message. Registers shall be readable on demand or periodically. The operator can define the operating mode of the registers as wrapping or stop when full. The operator may also flush the registers or stop recording at any time.

NOTE: Wrapping is the deletion of the earliest record to allow a new record when a register is full. Flushing is the deletion of all the records.

4.9.3 Performance management

Performance management consists of performance monitoring event processes, data collection and history processes along with thresholding and reporting functions. Performance monitoring consists of the first three items.

Within performance monitoring the concepts of "near-end" and "far-end" are used to refer to performance monitoring information associated with the two directions of transport in the case of a bi-directional transmission path. For a trail from A to Z:

- at node A the near-end information represents the performance of the unidirectional trail from Z to A, while the far-end information represents the performance of the unidirectional trail from A to Z;
- at node Z the near-end information represents the performance of the unidirectional trail from A to Z, while the far-end information represents the performance of the unidirectional trail from Z to A.

At either end of the trail (A or Z) the combination of near-end and far-end information present the performance of the two directions of the trail.

Performance monitoring event process

The performance monitoring event processing processes the information available from the performance monitoring primitives processing (basic functions) giving the performance primitives (EBC and DS) to derive the performance events (errored seconds, severely errored seconds and background block errors).

Near-end Performance Monitoring Event (NPME) function

Figure 20 presents the processes and their interconnect within the Near-end Performance Monitoring Event (NPME) function.

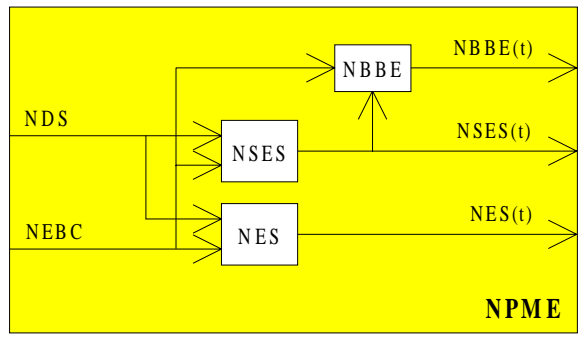

Figure 20: Near-end performance monitoring event (NPME) function

A Near-end Errored Second (NES) shall be generated if the defect second (NDS) is set or if the Near end Errored Block Count (NEBC) is greater or equal to 1: $NES(t) \leftarrow (NDS = true) \text{ or } (NEBC \geq 1)$.

A Near-end Severely Errored Second (NSES) shall be generated if the Near end Defect Second (NDS) is set or if the Near end Errored Block Count (NEBC) is greater or equal to 30 % of the blocks in a one second period: $NSES(t) \leftarrow (NDS = true) \text{ or } (NEBC \geq "30 \% \text{ of blocks in a one second period}")$.

The number of Near end Background Block Errors (NBBE) in a one second period shall be equal to the Near end Errored Block Count (NEBC) if the second is not a Near end Severely Errored Second (NSES). Otherwise (NSES is set), NBBE shall be zero. $NBBE(t) \leftarrow NEBC (NSES = false) \text{ or } 0 (NSES = true)$.

Far-end Performance Monitoring Event (FPME) function

Figure 21 presents the processes and their interconnect within the Far-end Performance Monitoring Event (FPME) function.

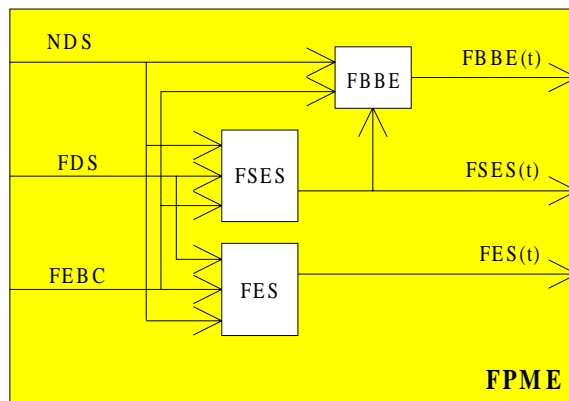

Figure 21: Far-end performance monitoring event (FPME) function

A Far-end Errored Second (FES) shall be generated if the Far end Defect Second (FDS) is set or if the Far end Errored Block Count (FEBC) is greater or equal to 1, and if that second is not a Near-end Defect Second (NDS): $FES(t) \leftarrow (NDS = \text{false}) \text{ and } ((FDS = \text{true}) \text{ or } (FEBC \geq 1))$.

A far-end Severely Errored Second (FSES) shall be generated if the Far end Defect Second (FDS) is set or if the Far end Errored Block Count (FEBC) is greater or equal to 30 % of the blocks in a one second period, and that second is not a Near-end Defect Second (NDS): $FSES(t) \leftarrow (NDS = \text{false}) \text{ and } ((FDS = \text{true}) \text{ or } (FEBC \geq \text{"30 \% of blocks in a one second period"}))$.

The number of Far end Background Block Errors (FBBE) in a one second period shall be equal to the Far end Errored Block Count (FEBC) if the second is not a Far end Severely Errored Second (FSES), and if that second is not a Near-end Defect Second (NDS). Otherwise, FBBE shall be zero. $FBBE(t) \leftarrow FEBC$ ($FSES = \text{false}$ and $NDS = \text{false}$) or 0 ($FSES = \text{true}$ or $NDS = \text{true}$).

Performance data collection

Performance data collection refers to the event counting associated with each of the performance events BBE, ES, SES as defined in ITU-T Recommendation G.826 [18], and any additional performance parameter defined in this ETS. The performance data collection as specified in ITU-T Recommendation M.2120 [25] bases on information for each direction of transport independently. This type is further referred to as performance data collection for maintenance purposes. This type of collection counts the events over fixed time periods of 15 minutes and 24 hours. Counting is stopped during unavailable time. These counters operate as follows:

15 minute counter:

The performance events (e.g. SES) are counted in a counter per event. These counters are called the current registers. At the end of the 15 minute period the contents of the current registers are transferred to the first of the recent registers, with a time stamp to identify the 15 minute period (including the day), after which the current register shall be reset to zero. It is an option not to transfer the content of a current register to a recent register if this content is zero (note 1). It shall be possible to reset an individual current register to zero by means of an external command.

NOTE 1: A capability should be provided to insure that, in the absence of reports, the reporting process is functioning properly.

Any register the content of which is suspect shall be flagged, using the "suspect interval flag" provided in ITU-T Recommendation Q.822 [26]. This flag shall be raised independently for far-end and near-end counts. Examples of conditions to raise this flag are provided in ITU-T Recommendation Q.822 [26].

24 hour counter:

The performance events (e.g. SES) are counted in a counter per event, independent of the 15 minute counters. These counters are called the current registers. It was agreed that it is up to the NE implementation to update the register counts. It is not required that it shall be done second by second basis. At the end of the 24 hour period the contents of the current registers are transferred to recent registers, with a time stamp to identify the 24 hour period, after which the current register shall be reset to zero. It shall be possible to reset an individual current register to zero by means of an external command.

Any register the content of which is suspect shall be flagged, using the "suspect interval flag" provided in ITU-T Recommendation Q.822 [26]. This flag shall be raised independently for far-end and near-end counts. Examples of conditions to raise this flag are provided in ITU-T Recommendation Q.822 [26].

Performance data collection during unavailable time

The onset and exit of unavailable time is defined in annex A of ITU-T Recommendation G.826 [18] and in ITU-T Recommendation M.2120 [25]. A period of unavailable time begins at the onset of ten consecutive SES. These ten seconds are part of unavailable time. A period of available time begins at the onset of ten consecutive non-SES. These ten seconds are part of available time. Performance monitoring event counting for ES, SES, and BBE shall be inhibited during unavailable time. The unavailability of a single direction shall inhibit the counting for that direction only.

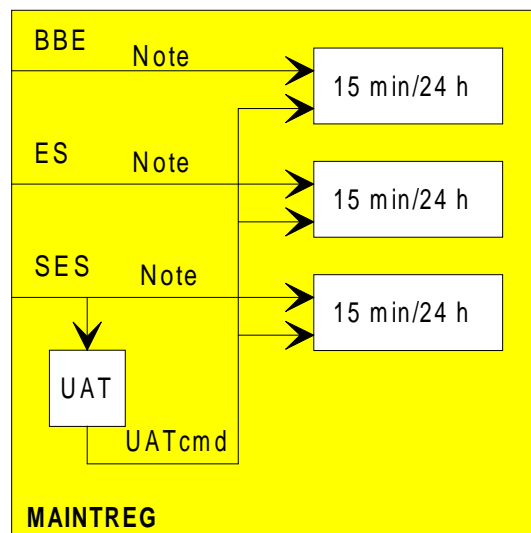

NOTE: The determination of (un)available time introduces (functionally) a delay of 10 seconds. This delay should be considered when counting BBE, ES, SES.

Figure 22: Performance monitoring data collection and history for maintenance purposes

Availability data collection

When a period of unavailability occurs, the beginning and ending of this period should be stored in a log in the NE, and as a consequence time-stamped. The NE should be able to store these data for at least 6 periods of unavailability.

Performance monitoring history

Performance history data are necessary to assess the recent performance of transmission systems. Such information can be used to sectionalise faults and to locate the source of intermittent errors. Historical data, in the form of performance monitoring event counts, may be stored in registers in the NE or in mediation devices associated with the NE. For specific applications, for example when only Quality Of Service (QOS) alarms are used, historical data may not be stored. All the history registers shall be time stamped.

The history registers operate as follows (see also figure 22):

- 15 minute registers:

The history of the 15 minute monitoring is contained in a stack of 16 registers per monitored event. These registers are called the recent registers. Every 15 minutes the contents of the current registers are moved to the first of the recent registers. When all 15 minute registers are used, the oldest information will be discarded.

- 24 hour registers:

The history of the 24 hour monitoring is contained in a single register per monitored event. This register is called the recent register. Every 24 hours the contents of the current registers are moved to the recent register (note 2).

NOTE 2: This implies that all 24 hour data is discarded after 24 hours.

Performance data reporting

Performance data stored in the NE may be collected by the operator for analysis without affecting the content of the register.

4.10 Synchronous Equipment Timing Source (SETS)

This function provides timing reference to the following functions: TTF, HOA, Sm_TT and S4_TT.

The Synchronous Equipment Timing Source (SETS) function represents the SDH Network Element clock. The SETS function includes an internal oscillator function and synchronous Equipment Timing Generator (SETG) function. The information flows associated with the SETS function are described with reference to figure 23.

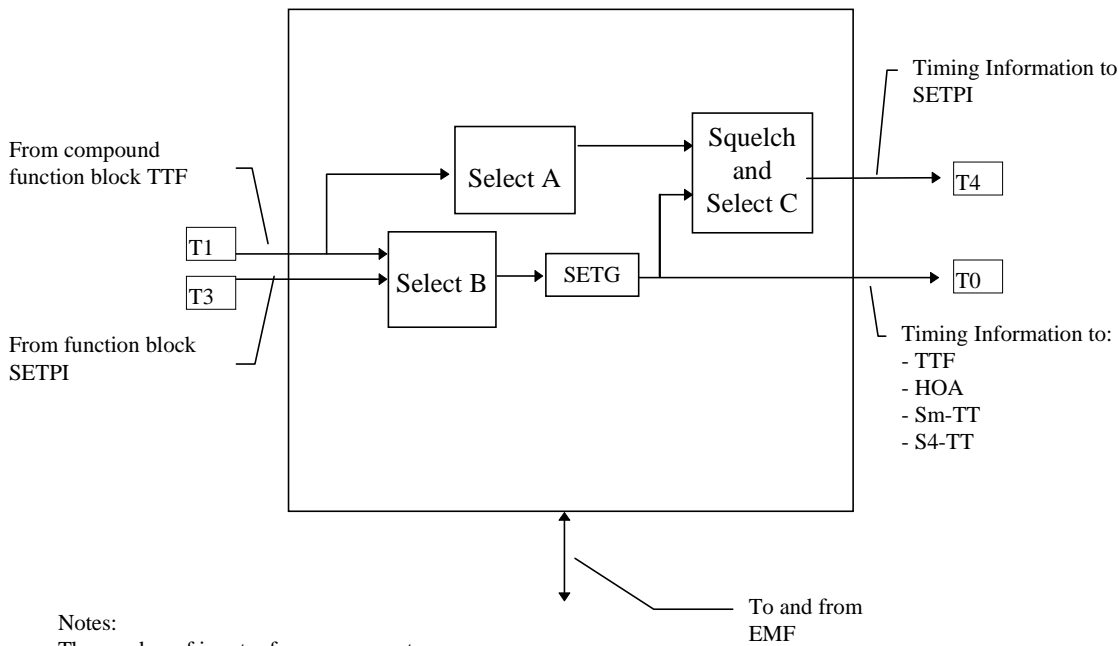

Notes:
The number of input references are not specified by this specification.
The selectors A and C are optional.

Figure 23: Synchronous Equipment Timing Source Function

The synchronization source may be selected from any of the reference points T1 or T3:

- T1 derived from STM-1 input signal;
- T3 derived from external synchronization reference signal (2 MHz signal from SETPI).

When the SETS is synchronized to a signal carrying a network frequency reference standard the short-term stability requirements at the T0 and T4 reference points are specified in ETS 300 462-1 [9] and ETS 300 462-5 [10].

Selector A (optional)

This function selects one reference synchronization source from a number of signals on T1 reference points derived from STM-1 signals.

Selector B

This function selects one reference synchronization source from a number of signals on T1 (derived from STM-1 input signal) and T3 (derived from external reference synchronization signal).

Selection process for Selector A and B

Input signal priority assignment: The function shall support the enabling or disabling of the inputs to the automatic selection process, independent for each output. An input shall be disabled when a priority "dis" has been assigned to it. An input shall be enabled when a priority between "1" and "K" has been assigned to it, where "K" is the maximum number of possible inputs. Priority "1" shall be the highest priority, priority "K" shall be the lowest priority. It shall be possible to assign the same priority to multiple inputs.

Table 11: Priority table

Priority value	Order
1	greatest
2	
3	
:	
K	
DIS	smallest

External commands: Several external commands are available to the user, (e.g. for maintenance purposes). These commands are independent and have different impact on the selection processes. The function shall support the following external commands:

- Clear: A clear (CLR) command clears the forced switch and manual switch commands.
- Clear_Lockout #p: A clear_lockout (CLRLO) #p command clears the lockout #p command. It results in adding the synchronization source #p to the set of nominated synchronization sources.
- Lockout #p: A Lockout (LO) #p command removes the synchronization source #p from the set of available synchronization sources to the reference selection process. Lockout #p commands can be issued to synchronization sources that are enabled. Multiple lock-out commands (e.g. LO #a, LO#b, LO #v) can be active at any one moment. Each lock-out command can be cleared by the corresponding "Clear Lock-Out" command. The lock-out command is cleared automatically if the locked-out synchronization source is disabled.
- Forced Switch #p: A forced switch (FSw) to #p command can be used to override the currently selected synchronization source, assuming the synchronization source #p is enabled and not locked out. The forced switch pre-empts the manual switch and a subsequent forced switch pre-empts the previous forced switch. If the source selected by the forced switch command (#p) is disabled or locked out, the forced switch command is automatically cleared. The forced switch command can be cleared by the "clear" command.

NOTE: A forced switch command to a synchronization source #p which is in the SF state will result in the NE entering holdover.

- Manual Switch #p command: A manual switch (MS) to #p command selects the synchronization source #p, assuming it is enabled, not locked out and not in signal fail. As such, these conditions have the effect that manual switching can only be used to override the assigned synchronization source priorities. A manual switch request pre-empts a previous manual switch request. If the source selected by the manual switch command (#p) is disabled, locked out or in signal fail, the manual switch command is automatically cleared. The manual switch command can be cleared by the "clear" command. The manual switch command is optional.

Selection:

The selection algorithm is based on priority only (QLmode = disabled). It shall operate as specified in annex A of ETS 300 417-6-1 [6]. It selects the timing reference with highest priority providing no signal fault exists.

The function shall support a hold-off and a Wait-to-Restore timer per selector.

- Hold-off Time (HOT): The HOT shall be applied to SF when it activates, before the condition shall be taken into account by the selection process.
- Wait To Restore (WTR): To prevent frequent operation of the selector due to an intermittent fault, a failed reference input signal become fault-free. After the failed reference meets this criteria, a fixed period of time will elapse before it is selectable again. Wait To Restore Time is defined as the time a reference be error free before it can be chosen as a timing reference. The WTR timer shall be activated when SF clears. The function shall support the provisioning of the WTR time between

0 minutes and 12 minutes in steps of 1 minute. A new value for the WTR timer shall become actual after the timer has expired.

Signal Fail on T3 signal(s): SF = true if LOS = true

Signal Fail on T1 signal(s): SF = true if (LOS = true or LOF = true)

Synchronous Equipment Timing Generator (SETG)

This function performs the system clock process. It consists of 3 main processes: time-base selector, mode selector, and time-base.

- Mode of operation

The function shall support the selection of one of the operational modes for the system clock process (command "SET Select operational mode"):

- Free-running mode;
- Locked mode;
- Holdover mode.

These modes are defined in ETS 300 462-1 [9].

The default shall be the free-running mode. This function works in free run mode when it never received timing from the date the equipment was set in service.

1) Time base selector

The function shall go holdover mode if during locked mode of operation SF = true. It shall revert to the normal input if SF = false. When the function does not receive a timing signal, it goes holdover immediately.

2) Mode selector

The function shall report the status of the time-base selector to the EMF. The status shall be "normal" or "holdover".

3) Time base

Bandwidth, transients, pull in and pull out ranges, noise, input and output jitter for locked mode operation, holdover accuracy and output phase deviation for holdover mode operation, frequency accuracy, transients, noise and output jitter for freerun mode operation shall be as specified in ETS 300 462-5 [10].

Loss of all incoming timing references (LTI) (T1 and T3) shall be reported to the EMF at reference point SETS_MP.

Selector C and squelching (optional)

This function is activated by an operator command. It selects either a T0 or T1 signal selected by selector A.

Squelching function: This function is provisioned by the operator to disable T4. It squelches the output timing reference to the SETPI function block if a signal fail is detected on the selected timing reference.

Notifications to EMF

Table 12: Notifications from SETS to EMF

Notifications and Failures
- Switch Report: Active synchronization port(p) - LTI - Status of the time-base selector

4.11 Synchronous Equipment Timing Physical Interface (SETPI)

The Synchronous Equipment Physical Interface function block provides the interface between the external 2 048 kHz synchronization signal and the SETS. The 2 048 kHz synchronization interface port shall be compliant with the physical characteristics described in paragraph 10 of ITU-T Recommendation G.703 [14].

To prevent alarms being raised and failures being reported during provisioning, the interface shall have the ability to enable or disable fault cause declaration. The interface shall be either in the "Monitored (MON)" or the "Not monitored (NMON)" state provisioned by the equipment manager.

Signal processing in the transmitter (Signal flow at i-to-SETPI in figure 1)

This signal flow only exists if the SETS can provide external synchronization.

The SETPI function takes timing information at reference point i and forms the transmit synchronization signal. The timing information is passed transparently to the synchronization interface.

This function is optional.

Signal processing in the receiver (Signal flow at i out of SETPI in figure 1)

The SETPI function extracts timing from the received synchronization signal. After decoding, it passes timing information to the SETS.

A LOS defect shall be detected according to subclause 13.2.2. of ETS 300 417-2-1 [3].

This function is optional.

Annex A (normative): Block diagram of the Network Adapter (NA)

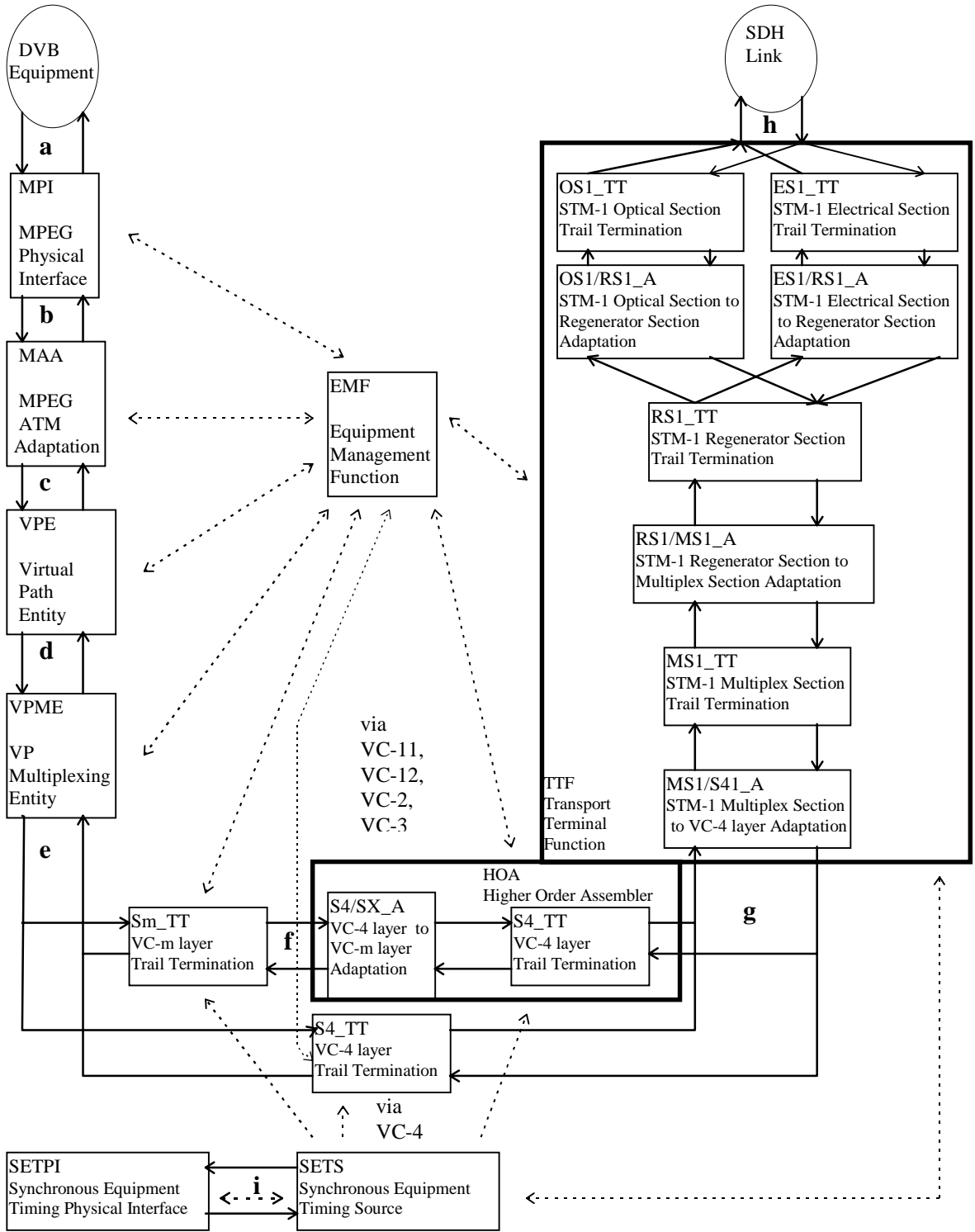

NOTE 1: Block Sm-TT: allowed values for m: m = 11, 12, 2 or 3.

NOTE 2: In case of the transport of ATM cells by a lower order VC (VC-11, VC-12, VC-2 or VC-3), the blocks Sm_TT and HOA are necessary. If ATM cells are directly mapped into a VC-4, only block S4_TT is necessary, the blocks Sm_TT and HOA are not present in that case.

NOTE 3: For the SDH Physical Interface, for the realization of the electrical interface the blocks ES/RS_A and ES_TT are necessary, for the realization of the optical interface the blocks OS/RS_A and OS_TT are necessary.

Figure A.1: Functional blocks of the SDH Network Adapter

Annex B (informative): Mechanism of the adaptive clock method

The adaptive clock method is a general method for source clock frequency recovery. No explicit timing information of the source clock is transported by the network, the method is based on the fact that the amount of transmitted data is an indication of the source frequency, and this information can be used at the receiver to recover the source clock frequency.

The adaptive clock method is implemented at the receiving AAL. The implementation of the method is not standardized. One possible method to measure the amount of data is to use the fill level of the AAL user data buffer. The following is the general description of this method and does not preclude other adaptive clock methods.

The receiver writes the received data into a buffer, and then reads it out using a locally generated clock. Therefore the fill level of the buffer depends on the source frequency and it is used to control the frequency of the local clock. Operations are the following: the fill level of the buffer is continuously measured and the measure is used to drive the phase-locked loop generating the local clock. The method maintains the fill level of the buffer around its medium position. To avoid buffer underflow or overflow, the fill level is maintained between two limits. When the level in the buffer goes to the lower limit, this means the frequency of the local clock is too high compared to the one of the source and so it has to be decreased. When the level in the buffer goes to upper limit, the frequency of the local clock is too low compared to the one of the source, and so it has to be increased.

It is pointed out that the compensation of cell delay variation is also performed by the adaptive clock method. However, a cell delay variation is not to be expected if no ATM network is to be crossed.

Annex C (informative): Enabling/Disabling the Header Error Control functions (HEC)

The Header Error Control (HEC) functions of the ATM cells, as described in ITU-T Recommendation I.432 [22], can correct single errors and detect almost all multiple errors in the header. In an ATM network, when the HEC detects errors that it cannot correct, the whole cell is discarded and its payload is lost for an end-to-end connection.

When a FEC is applied on a link, it can generate error bursts if it fails to correct errors. In presence of error bursts, the single-bit correcting code of the HEC is unable to correct most errors encountered. In an error bursts environment the probability of discarding cells is proportional to the BER and not to the square of the BER as in a random error environment. Although bursts of errors due to error correction failures have different lengths and rate of occurrence according to the different FEC schemes, this behaviour would apply to all transmission systems using FEC.

Therefore for a given bit error probability, the discarded cell probability in presence of error bursts is definitely different from the discarded cell probability in presence of randomly distributed errors.

It is then recommended to disable the HEC functions when using the ATM cell format for transporting an MPEG2-TS over an SDH network based on transmission systems using FEC (e.g. radio relays, satellites). This measure avoids unwanted and unnecessary degradation of the end-to-end quality.

Annex D (informative): Transmission capacity of the Network Adapter

Transmission Capacity of the Network Adapter for MPEG2-TSs respectively RS-coded MPEG2-TSs using different Virtual Containers for the transmission inside an SDH network is given in table D.1.

Table D.1

Type of container	Container capacity	Example of transmission capacity for MPEG2-TSs respectively RS-coded MPEG2-TSs
C-4	149 760 kbit/s	128 656 kbit/s
C-3	48 384 kbit/s	41 566 kbit/s
C-2	6 784 kbit/s	5 828 kbit/s
C-12	2 176 kbit/s	1 869 kbit/s
C-11	1 600 kbit/s	1 375 kbit/s

Annex E (normative): Transport within Sub-STM-1 at 51 Mbit/s

A method for the transmission of MPEG2-TS packets respectively RS coded MPEG2-TS packets using a data rate of 51 Mbit/s is described in this annex. The data is transported within a VC-3 Container, that also can contain other Lower Order Virtual Containers, and the signal processing can be described using additional functional blocks. The description bases on functional blocks mentioned in ITU-T Recommendation F.750-1 [13] where a sub-STM-1 transmission rate of 51 840 kbit/s is defined in order to connect Radio-Relay (RR) equipment, although this bit rate does not represent an SDH or a NNI bit rate. The functional blocks for this method of transmission are shown in figure E.1.

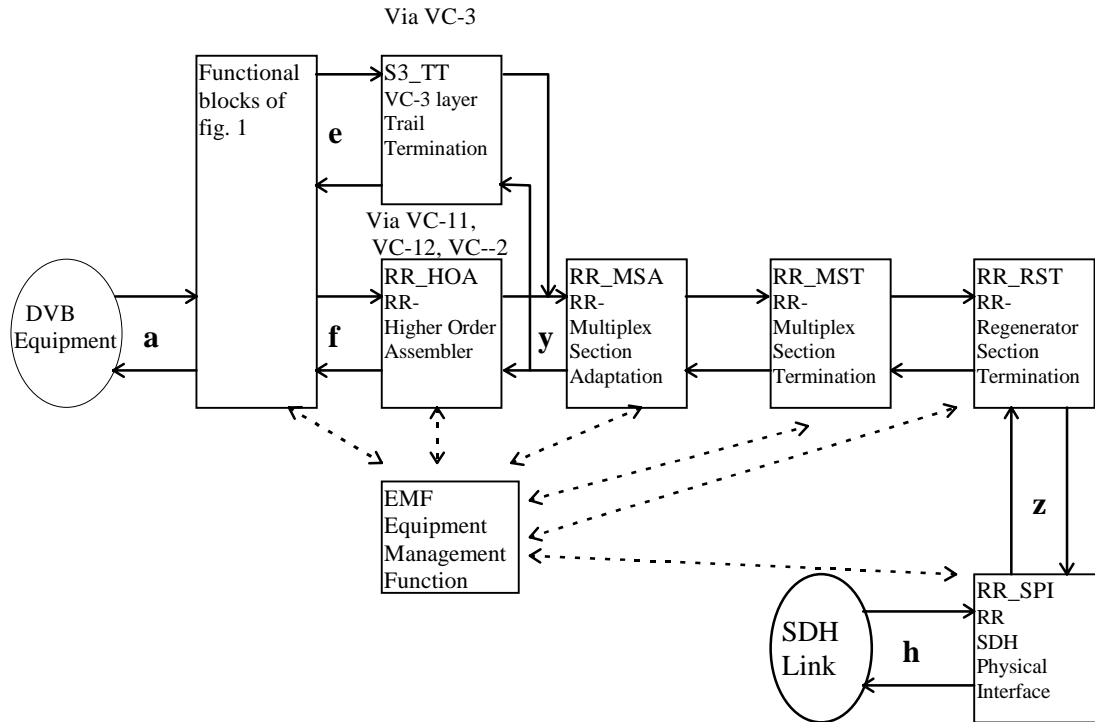

Figure E.1: Functional blocks for the transport at 51 Mbit/s

Interfaces a, e, f and h correspond to the interfaces specified in figure 1 of this ETS and the functional blocks necessary for the processing of the data between interfaces a and f are identical to the functional blocks already introduced in figure 1. Therefore, in this annex only the additional functional blocks are described.

Radio-Relay (RR) Higher Order Assembler (HOA)

The RR HOA function is responsible for adaptation of the LOVCs into the corresponding HOVC (VC-3) including VC-3 POH generation and interpretation. This signal path has to be used if the MPEG data to be transported is contained in a VC-11, VC-12 or VC-2 Virtual Container.

RR HOA is a compound function which consists of two functional blocks (see figure E.2) reflecting the logical structure that already was used for the description of the Higher Order assembler in subclause 4.6 of this ETS.

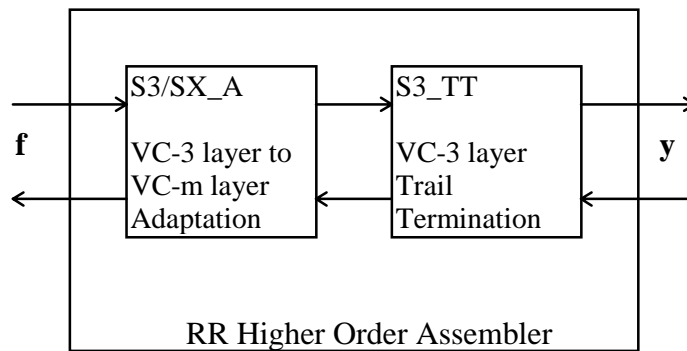
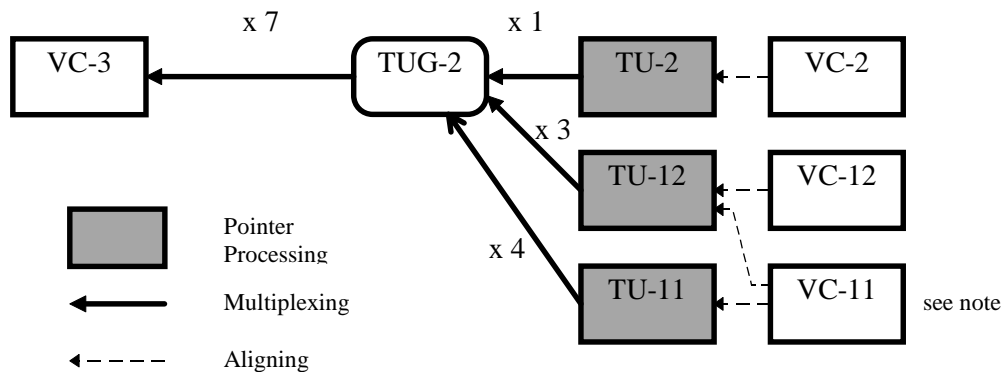

Figure E.2: RR HOA components

Based on ITU-T Recommendation G.707 [15], the multiplexing structure of LOVCs into VC-3 is shown in figure E.3. VC-3 can be used to transport VC-11s, VC-12s, VC-2s.



NOTE: In Europe VC-11 is transported in TU-12.

Figure E.3: Multiplexing structure of LOVCs into VC-3

Because each of the LOVCs is a frame synchronous structure, whose frame phase is uncorrelated with the supporting VC-3, the information of this phase alignment be transferred together with the associated LOVC in the VC-3 payload. The frame alignment between LOVCs and VC-3 is also functional part of the RR HOA. Since the frame alignment is dynamic it is not only able to accommodate for differences in the phases between VC-3 and LOVCs but can correct for different frame rates as well.

The frame alignment information is the offset in bytes between the LOVC frame and the corresponding VC-3 frame. This offset is coded as binary integer and called tributary unit pointer. The combination of a pointer value and the corresponding VC-m is called a Tributary Unit (TU-m).

Several TUs are combined into a Tributary Unit Group (TUG). Only one type of TUG is used here: TUG-2. TUG-2 is used to transport up to four TU-11, up to three TU-12 or one TU-2.

A VC-3 can accommodate up to 7 TUG-2, where each TUG-2 may possess a different payload structure.

The employed frame structures, pointers and usage of pointers are defined in ITU-T Recommendation G.707 [15]. TU-2, TU-11 and TU-12 numbering scheme within the VC-3 and the corresponding time slot allocation into the VC-4 are described in figures 7 to 12 of ITU-T Recommendation G.707 [15]. Unused frame positions are fixed stuff.

NOTE 1: The use of more than one LOVC is optional.

These two functional blocks are also responsible for the VC-3 POH generation and interpretation. The VC-3 POH is described in subclause 4.5.

Table E.1 indicates for each VC-3 POH byte if it is used by RR HOA in the context of the SDH network adapter and, if necessary, any setting of particular value.

NOTE 2: One part of the VC-3 POH is processed by S3/SX_A, the other by S3_TT.

Table E.1: VC-3 POH

VC-3 POH bytes	Used	Particular value
J1 - Path Trace	Yes (see S3_TT)	-
B3 - BIP-8	Yes (see S3_TT)	-
C2 - Signal Label	Yes (see S3/SX_A)	Set to "02H"
G1 - REI + RDI + spare	Yes (see S3_TT)	-
F2 - Path user channel	No	Undefined
H4 - Position indicator	Yes (see S3/SX_A)	see subclause 8.3.8 of ITU-T Recommendation G.707 [15]
F3 - Path user channel	No	Undefined
K3 - APS + spare	No	Undefined
N1 - Network operator byte	No	Undefined

Signal processing in the transmitter (Signal flow from f-to-y in figure E.1)

Data at f is a LOVC or a set of LOVCs coming from Sm_TT.

S3/SX_A:

This function generates the LOVC pointers depending on the differential phase differences between HOVC and LOVCs. Pointer and LOVC are combined into TU-2/TU-12/TU-11 for VC-2/VC-12/VC-11 input. The pointer bytes coding is described in ITU-T Recommendation G.707 [15]. The pointer generation shall be done analogue to the description in annex A of ETS 300 417-1-1 [2].

This function multiplexes the resulting TUs into TUG-2 if the incoming signal is a VC-11 or VC-12. If the incoming signal is a VC-2, one TU-2 is mapped directly into TUG-2. Up to 7 resulting TUG-2s shall be multiplexed into one C-3.

NOTE 3: According to ETS 300 147 [1], a VC-11 is transported by a TU-12 in Europe.

Two payload specific bytes are also added to the VC-3 POH:

- C2 byte: this byte conveys the signal label and shall be set to "02H" corresponding to "TUG structure" as described in table 7 of ITU-T Recommendation G.707 [15].
- H4 byte: This byte conveys a multiframe indicator as specified in subclause 8.3.8 of ITU-T Recommendation G.707 [15].

S3_TT:

This function is described in subclause 4.5 of this ETS.

The VC-3 output is transferred to RR MSA.

Signal processing in the receiver (Signal flow from y-to-f in figure 1)

The RR HOA receives VC-3 as input signal from RR MSA.

S3-TT:

This function is described in subclause 4.5 of this ETS.

S3/SX_A:

This function extracts bytes H4 and C2 from the VC-3 POH.

The received C2 byte (conveying the signal label) is compared with the expected value ("02H"). This comparison is used to detect PLM (Payload Label Mismatch) defect.

This byte is recovered to be used as a multiframe indicator for the TU-2/TU-11/TU-12. This byte is used as input to detect LOM defect.

Afterwards this function performs the demultiplexing of the VC-3 payload. The TUG-2s are extracted from VC-3. If one TUG-2 contains a TU-2, it is extracted from TUG-2. If there is no TU-2 within the TUG-2, up to three TUG-12 or up to four TU-11 are contained within the TUG-2. These are extracted from TUG-2. Each of these TUG-2s is split up into TU-2s or TU-12s or TU-11s.

This function performs also the TU pointers interpretation. The TU pointer bytes coding is described in ITU-T Recommendation G.707 [15]. The pointer interpretation shall be done analogue to the description in annex B of ETS 300 417-1-1 [2], that also includes the detection of AIS and LOP defects.

Based on the incoming reference clock and the actual TU pointer value the gapped LOVC clock is regenerated.

The recovered VC-m (m = 11, 12, 2) and its gapped clock are transferred to Sm_TT for further processing.

S3_TT

This function acts as a termination for the payload independent OverHead information of a VC-3. This signal path has to be used if the MPEG data to be transported is directly mapped into a VC-3 Virtual Container.

To prevent alarms being raised and failures being reported during path provisioning, the interface shall have the ability to enable or disable fault cause declaration. The interface shall be either in the "Monitored (MON)" or the "Not monitored (NMON)" state provisioned by the equipment manager.

Signal processing in the transmitter (Signal flow from e-to-y in figure E.1)

This function is described in subclause 4.5 of this ETS.

Signal processing in the receiver (Signal flow from y-to-e in figure E.1)

This function is described in subclause 4.5 of this ETS.

Functional blocks between interfaces y and z

In annex A of ITU-T Recommendation G.707 [15] a frame structure for a SDH-based section operating at 51 840 kbit/s is specified. This structure uses a Virtual Container-3 (VC-3) that is interrupted by two additional columns and a derivative of the STM-1 SOH which is called STM-RR SOH according to ITU-R Recommendation F.750-1 [13] where such a frame structure is used for Radio Relay (RR) systems inside SDH-based networks. ATM cells are transported inside the VC-3 which is preceded by the STM-RR SOH and an AU-3 Pointer. The resulting frame structure is shown in figure E.4. Fixed stuff is inserted in columns 30 and 59. The byte in each row of the two columns of fixed stuff shall be the same. These columns are not part of the VC-3.

The pointer value is a binary number with a range of 0 to 260 indicating the offset in three byte increments. The value of this pointer using 10 bits shall be generated according to subclause 8.1 of ITU-T Recommendation G.707 [15], whose description shall also be taken for the setting of byte H3 which is used in case of a negative frequency offset. The most significant bits of the pointer value are conveyed in bits 6 to 8 of byte H1, the remaining 8 bits are conveyed in byte H2. Bits 1 to 4 of byte H1 carry a New Data Flag which allows an arbitrary change of the pointer value. Their values shall be set in accordance with the description given in subclause 8.1.4 of ITU-T Recommendation G.707 [15]. The pointer generation shall be done analogue to the description in annex A of ETS 300 417-1-1 [2].

Signal processing in the receiver

The pointer processing function provides accommodation for wander and plesiochronous offset in the received signal with respect to the synchronous equipment timing reference. The processing function shall perform the interpretation according to annex B of ETS 300 417-1-1 [2]. The process shall maintain its current phase on detection of an invalid pointer and shall search in parallel for a new offset. Two defects can be detected by the processing algorithm, a Loss Of Pointer (LOP) and an AIS. If either of these failure conditions are detected, the function shall output an all-ONEs (AIS) signal within 250 μ s. On clearing of these defects, the AIS signal shall be removed within 250 μ s.

Performance Monitoring

For performance monitoring, the information passed to the EMF is the 1 second count.

Defects are filtered by the one second filter.

This function generates the following performance parameters:

- N_DS: Every second with at least one occurrence of LOP or AIS defect shall be indicated as a Near-end Defect Second (N_DS).

At the end of each one second interval the contents of the N_DS counter is reported to the EMF.

RR Multiplex Section Termination

This function generates the RR MSOH in the process of forming an Sub-STM-1 frame signal and terminates the RR-MSOH in the reverse direction.

Signal processing in the transmitter

- a) BIP-8 Calculation (Byte B2)
This byte is allocated for a multiplex section error monitoring function. Bit Interleaved Parity BIP-8 using even parity is computed over all bits of the previous frame except for the first three rows of RR-SOH after and is placed in the byte B2 of the current frame before scrambling.
- b) Automatic Protection Switching (APS) Channel (Byte K1 and Bits 1 to 5 of Byte K2)
These bytes are allocated for APS signalling for the protection of the multiplex section. The setting of these bytes depends on the chosen maintenance strategy of the network operator. Therefore, these bytes are undefined.
- c) Multiplex Section - Remote Defect Indication (MS-RDI) (Bits 6 to 8 of Byte K2)
If an incoming section defect or an AIS is detected in the receiving direction, the bit pattern "110" shall be inserted in positions 6, 7, and 8 of the K2 byte before scrambling within 250 μ s in order to return an indication to the transmit end. On the clearing of the defect, the bit pattern "000" shall be inserted in positions 6, 7, and 8 of the K2 byte before scrambling within 250 μ s.

NOTE 4: In case of unidirectional transmission, there is no receiving path termination and the MS-RDI shall be set to a logical "0".

- d) Data Communication Channel DCC RR MSOH (Bytes D4 - D12)
A 576 kbit/s channel is defined using bytes D4 to D12 as a DCC in a Multiplex section. These bytes are undefined.

- e) Synchronization Status (Bits 5 to 8 of Byte S1)
These bits are used for the signalling of the SDH synchronization quality level. Their values shall be set to "0000" according to table 5 of ITU-T Recommendation G.707 [15] which signals that the quality level is unknown.
- f) Multiplex Section - Remote Error Indication (MS-REI) (Byte M1)
If an errored block has been detected by the BIP-8 in the receiving direction, this byte shall be used to convey the number of interleaved bit blocks that have been detected in error by the BIP-8 in the range of [0, 8]. The bits of this byte shall be set as follows:

Table E.2: MS-REI allocation at 51 840 kbit/s

M1 code Bits 2 - 8 2 3 4 5 6 7 8	Code meaning
0 0 0 0 0 0	0 BIP violations
0 0 0 0 0 1	1 BIP violation
0 0 0 0 1 0	2 BIP violations
0 0 0 0 1 1	3 BIP violations
:	:
0 0 0 1 0 0 0	8 BIP violations
0 0 0 1 0 0 1	0 BIP violations
0 0 0 1 0 1 0	0 BIP violations
:	:
1 1 1 1 1 1 1	0 BIP violations
NOTE: Bit 1 of byte M1 is undefined.	

NOTE 5: In case of unidirectional transmission, there is no receiving path termination and the MS-REI shall be set to a logical "0".

- g) Orderwire RR MSOH (Byte E2)
This byte may be used to provide orderwire channels for voice communication. Byte E2 is part of the RR-MSOH and may be accessed at multiplex section terminations. This byte is undefined.

Signal processing in the receiver

- a) BIP-8 Checking (Byte B2)
The error monitoring byte B2 is recovered from the RR-MSOH. A BIP-8 code is computed for the frame. The computed BIP-8 value for the current frame is compared with the recovered B2 byte from the following frame. A difference between the computed and the recovered value is taken as evidence of one or more errors in the computation block.
- b) Automatic Protection Switching (APS) Channel (Byte K1 and Bits 1 to 5 of Byte K2)
Byte K1 and bits 1 to 5 of byte K2 are ignored.
- c) Multiplex Section - Remote Defect Indication (MS-RDI) (Bits 6 to 8 of Byte K2)
The MS-RDI is recovered from bits 6 to 8 of the K2 byte in order to enable single ended maintenance of a multiplex section. An RDI defect shall be declared when the bit pattern "110" is observed in bits 6, 7, and 8 of byte K2 in at least five consecutive frames. The RDI defect shall be cleared when any bit pattern other than "110" in bits 6,7 and 8 of byte K2 is received in at least five consecutive frames. If the function is in the MON state, the RDI defect is reported to the EMF.

These bits are also used to detect an AIS. If at least 5 consecutive frames contain the "111" pattern in bits 6,7 and 8 of the K2 byte, an AIS defect shall be detected. AIS shall be cleared if in at least 5 consecutive frames any pattern other than the "111" is detected in bits 6, 7, and 8 of byte K2.

NOTE 6: In case of unidirectional transmission, the detection of RDI is not performed.

- d) Data Communication Channel DCC RR MSOH (Bytes D4 - D12)
These bytes are ignored.

- e) Synchronization Status (Bits 5 to 8 of Byte S1)
This byte is ignored.
- f) Multiplex Section - Remote Error Indication (MS-REI) (Byte M1)
The MS-REI is recovered from byte M1 in order to enable single ended maintenance of a bi-directional multiplex section. The evaluation of this byte shall be done using the information given in table E.2. The MS-REI shall be used to monitor performance of the reverse direction of transmission.

NOTE 7: In case of unidirectional transmission, the M1 byte is ignored.

- g) Orderwire RR MSOH (Byte E2)
This byte is ignored.
- h) Performance Monitoring
For performance monitoring, the information passed to the EMF is the 1 second count.

One second filters perform a simple integration of errored blocks by counting during a one second interval. In addition, defects are filtered by the one second filter.

This function generates the following performance parameters:

- N_EBC: Every second, the number of errored near-end blocks (N_B) within that second is counted as the Near-end Error Block Count (N_EBC). A N_B is errored if one or more BIP-8 violations are detected.
- F_EBC: Every second, the number of errored far-end blocks (F_B) within that second is counted as the Far-end Error Block Count (F_EBC). A F_B is errored if the MS-REI count indicates one or more errors.
- N_DS: Every second with at least one occurrence of AIS shall be indicated as a Near-end Defect Second (N_DS).
- F_DS: Every second with at least one occurrence of RDI defect shall be indicated as a Far-end Defect Second (F_DS).

If the function is in the MON state, at the end of each one second interval the contents of N_EBC, F_EBC, N_DS and F_DS counters are reported to the EMF.

NOTE 8: In case of unidirectional transmission, only Near-end performance monitoring is processed.

RR Regenerator Section Termination

This function generates the RR RSOH in the process of forming an Sub-STM-1 frame signal and terminates the RR RSOH in the reverse direction.

Signal processing in the transmitter

- a) Frame Alignment (Bytes A1 and A2)
The frame alignment bytes A1 and A2 are inserted according to subclauses 9.2.2 of ITU-T Recommendation G.707 [15] using for A1 the bit pattern "11110110" and for A2 the bit pattern "00101000". The frame alignment word is composed of the A1 byte followed by the A2 byte.
- b) Regenerator Section Trace (Byte J0)
This byte is used to transmit repetitively an Access Point Identifier which is carried by a TTI so that a section receiver can verify its continued connection to the intended transmitter in order to make sure that data is not delivered to the wrong destination. For this check a 16 byte frame is used transmitted in byte J0 of successive frames. The value of this byte shall be set in accordance with the description given in subclause 7.1 of ETS 300 417-1-1 [2].

- c) BIP-8 Calculation (Byte B1)
Bit Interleaved Parity BIP-8 using even parity is computed over all bits of the previous frame after scrambling and is placed in the B1 byte of the current frame before scrambling.
- d) Orderwire RR RSOH(Byte E1)
This byte may be used to provide orderwire channels for voice communication. Byte E1 is part of the RR RSOH and may be accessed at regenerators. This byte is undefined.
- e) User Channel (Byte F1)
This byte is reserved for user purposes and is therefore undefined.
- f) Data Communication Channel DCC RR RSOH (Bytes D1 - D3)
A 192 kbit/s channel is defined using bytes D1, D2 and D3 as a DCC in a Regenerator Section. These bytes are undefined.
- g) Scrambling
In order to prevent long sequences of logical "0"s or "1"s, the content of every frame excluding the first row of the RR-SOH is scrambled by using a generating polynomial $x^7 + x^6 + 1$. The operation of the scrambler shall be in accordance with subclause 6.5 of ITU-T Recommendation G.707 [15].

Signal processing in the receiver

- a) Descrambling
The content of every frame excluding the first row of the RR-SOH shall be descrambled in accordance with the description given in subclause 6.5 of ITU-T Recommendation G.707 [15].
- b) Frame Alignment (Bytes A1 and A2)
This function shall perform the frame alignment of the 51 840 kbit/s signal in order to recover the frame start signal of a frame. Frame alignment shall be found by searching for the A1 and the A2 bytes contained in the signal. The frame shall be continuously checked with the presumed frame start position for alignment.

Frame alignment is deemed to have been lost (entering Out Of Frame state (OOF)) when 5 consecutive Frame Alignment Words (FAWs) (1 A1 byte followed by 1 A2 byte) are detected in error.

Frame alignment is deemed to have been recovered (entering In Frame state, IF) when 2 consecutive non-errored FAWs are found.

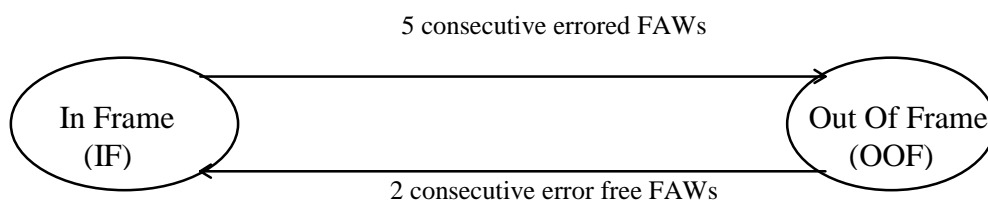

Figure E.7: Frame alignment state diagram

If the frame alignment is deemed to be lost (OOF state), a Loss Of Frame defect shall be set-up. The LOF defect shall be cleared when the frame alignment is deemed to have been recovered (IF state). On declaration of LOF, the function shall output an all-ONEs (AIS) signal within 250 μ s. On clearing of LOF, the function shall output normal data within 250 μ s. If the function is in the MON state, the LOF defect is reported to the EMF.

- c) Regenerator Section Trace (Byte J0)
This byte shall be recovered from the RR-RSOH and shall be evaluated to detect the received TTI. The application and acceptance and mismatch detection process shall be performed as specified in subclauses 7.1 and 8.2.1.3 of ETS 300 417-1-1 [2].

The accepted value of the received Trail Trace Identifier (TTI) is compared with the expected value. A difference in the comparison results in a Trace Identifier Mismatch (TIM) defect declaration. The TIM

defect shall be cleared if the accepted value equals the expected one. On declaration of TIM, the function shall output an all-ONEs (AIS) signal within 250 μ s. On clearing of TIM, the function shall output normal data within 250 μ s. If the function is in the MON state, the TIM defect is reported to the EMF. It shall be possible to disable the TIM defect by a configuration command from the EMF.

NOTE 9: The detection of TIM defect is described in subclause 8.2.1.3 of ETS 300 417-1-1 [2].

- d) BIP-8 Checking (Byte B1)
Byte B1 shall be recovered from the RR RSOH after descrambling and shall be compared with the computed BIP-8 over all bits of the previous frame before descrambling. A difference between the computed value and the recovered value is taken as evidence of one or more errors in the frame.
- e) Orderwire RR RSOH (Byte E1)
This byte is ignored.
- f) User Channel (Byte F1)
This byte is ignored.
- g) Data Communication Channel DCC RR RSOH (Bytes D1 - D3)
These bytes are ignored.
- h) Performance Monitoring
For performance monitoring, the information passed to the EMF is the 1 second count.

One second filters perform a simple integration of errored blocks by counting during a one second interval. In addition, defects are filtered by the one second filter.

This function generates the following performance parameters:

- N_EBC: Every second, the number of errored near-end blocks (N_B) within that second is counted as the Near-end Error Block Count (N_EBC). A N_B is errored if one or more BIP-8 violations are detected.
- N_DS: Every second with at least one occurrence of LOF or TIM defect shall be indicated as a Near-end Defect Second (N_DS).

If the function is in the MON state, at the end of each one second interval the contents of N_EBC and N_DS counters are reported to the EMF.

RR SDH Physical Interface

The RR SDH Physical Interface provides the physical medium dependent functions between the RR-SOH Adaptation and the physical medium. This interface is specified for a data rate of 51 840 kbit/s.

To prevent alarms being raised and failures being reported during path provisioning, the interface shall have the ability to enable or disable fault cause declaration. The interface shall be either in the "Monitored" (MON) or the "Not monitored" (NMON) state provisioned by the equipment manager.

Signal processing in the transmitter (Signal flow from z-to-h in figure E.1)

This interface provides the line encoding of the 51 840 kbit/s information signal and generates the electrical signal at the output port in transmitting direction.

The function shall perform a B3ZS encoding and it shall generate the electrical signal according to the descriptions given in appendix 1 of ITU-R.Recommendation F.750-1 [13].

Signal processing in the receiver (Signal flow from h-to-z in figure E.1)

The interface regenerates the received 51 840 kbit/s signal at the input port, recovers the bit timing and provides the line decoding in receiving direction. It passes the regenerated information signal and the recovered clock to RR-SOH adaptation.

The function shall operate without any error when any combination of the following signal conditions exists at the input:

- an input electrical level with any value in the range as specified in appendix 1 of ITU-R Recommendation F.750-1 [13];
- signal bit rate within the range as specified in appendix 1 of ITU-R Recommendation F.750-1 [13].

A LOS defect shall be detected for a 51 840 kbit/s signal applying the mechanism given in subclause 8.2.1.6 of ETS 300 417-1-1 [2]. In the event of LOS defect, an all-ONE's (AIS) DATA signal - complying to the frequency limits of this interface - shall be applied at reference point f accompanied by a suitable reference timing signal within 250 μ s. Upon termination of LOS, the all-ONE's signal shall be terminated within 250 μ s. If the function is in the MON state, the LOS defect is reported to the EMF.

General characteristics:

Bit rate: 51 840 kbit/s \pm 20 ppm

Code: Bipolar with 3 Zero Substitution (B3ZS). A description of this code is given in annex F.

Lines in each direction of transmission: One coaxial pair

Specifications at the output and input port: See table E.3

Table E.3: Specifications of the 51 840 kbit/s interface

Pair in each direction	One coaxial pair
Load impedance	75 Ω resistive \pm 5 %
Signal power measured with a filter having an equivalent characteristic of a low pass Butterworth filter with a cut-off frequency of 207,36 MHz	Between -2,7 dBm and 4,7 dBm
Pulse shape	Eye pattern according to appendix 1 of ITU-R. Recommendation F.750-1 [13]

Annex F (informative): Definition of codes

Bipolar with 3 Zero Substitution (B3ZS)

This code is an AMI code with the exception that each block of 3 successive zeros is replaced by 00V or B0V. The choice of 00V or B0V is made in such a way that the number of pulses conforming to the AMI rule between consecutive V pulses is odd. In other words, successive V pulses are of alternate polarity.

Coded Mark Inversion (CMI)

This code is a two amplitude level code. The binary 1 bits are represented by either of the amplitude levels, for one binary unit time interval, in such a way that the level alternates for successive binary ones. The binary 0 bits are represented by both amplitude levels, each for half a binary unit time interval, in such a way that there is always a positive transition at the midpoint of this time interval.

History

Document history			
February 1997	Public Enquiry	PE 9726:	1997-02-28 to 1997-06-27
December 1997	Vote	V 9809:	1997-12-30 to 1998-02-27
March 1998	First Edition		