



EUROPEAN
TELECOMMUNICATION
STANDARD

ETS 300 581-1

November 1995

Source: ETSI TC-SMG

Reference: DE/SMG-020602

ICS: 33.060.55

Key words: European digital cellular telecommunications system, Global System for Mobile communications (GSM)

**European digital cellular telecommunications system;
Half rate speech
Part 1: Half rate speech processing functions
(GSM 06.02)**

ETSI

European Telecommunications Standards Institute

ETSI Secretariat

Postal address: F-06921 Sophia Antipolis CEDEX - FRANCE

Office address: 650 Route des Lucioles - Sophia Antipolis - Valbonne - FRANCE

X.400: c=fr, a=atlas, p=etsi, s=secretariat - **Internet:** secretariat@etsi.fr

Tel.: +33 92 94 42 00 - Fax: +33 93 65 47 16

*

Copyright Notification: No part may be reproduced except as authorized by written permission. The copyright and the foregoing restriction extend to reproduction in all media.

© European Telecommunications Standards Institute 1995. All rights reserved.

Contents

Foreword	5
1 Scope	7
2 Normative references	7
3 Definitions and abbreviations	8
3.1 Definitions	8
3.2 Abbreviations	8
4 General.....	9
5 Half rate speech transcoding	10
6 Half rate Discontinuous Transmission (DTX).....	10
7 Half rate Voice Activity Detection (VAD)	11
8 Half rate comfort noise insertion	11
9 Half rate lost speech frame substitution and muting	11
10 Half rate codec homing	12
History.....	13

Blank page

Foreword

This European Telecommunication Standard (ETS) has been produced by the Special Mobile Group (SMG) Technical Committee of the European Telecommunications Standards Institute (ETSI).

This ETS specifies the half rate speech traffic channels for the European digital cellular telecommunications system. This ETS corresponds to GSM technical specification, GSM 06.02, version 4.0.2 and is part 1 of a multi-part ETS covering the half rate speech traffic channels as described below:

GSM 06.02	ETS 300 581-1: "European digital cellular telecommunications system; Half rate speech Part 1: Half rate speech processing functions".
GSM 06.20	ETS 300 581-2: "European digital cellular telecommunications system; Half rate speech Part 2: Half rate speech transcoding".
GSM 06.21	ETS 300 581-3: "European digital cellular telecommunications system; Half rate speech Part 3: Substitution and muting of lost frames for half rate speech traffic channels".
GSM 06.22	ETS 300 581-4: "European digital cellular telecommunications system; Half rate speech Part 4: Comfort noise aspects for half rate speech traffic channels".
GSM 06.41	ETS 300 581-5: "European digital cellular telecommunications system; Half rate speech Part 5: Discontinuous Transmission (DTX) for half rate speech traffic channels".
GSM 06.42	ETS 300 581-6: "European digital cellular telecommunications system; Half rate speech Part 6: Voice Activity Detection (VAD) for half rate speech traffic channels".
GSM 06.06	ETS 300 581-7: "European digital cellular telecommunications system; Half rate speech Part 7: ANSI-C code for the GSM half rate speech codec".
GSM 06.07	ETS 300 581-8: "European digital cellular telecommunications system; Half rate speech Part 8: Test vectors for the GSM half rate speech codec".

NOTE: TC-SMG has produced documents which give the technical specifications for the implementation of the European digital cellular telecommunications system. Historically, these documents have been identified as GSM Technical Specifications (GSM-TS). These TSs may have subsequently become Interim European Telecommunication Standards (I-ETSS), (Phase 1), or European Telecommunication Standards (ETSS), (Phase 2), whilst others may become ETSI Technical Reports (ETRs).

Transposition dates	
Date of adoption of this ETS:	27 October 1995
Date of latest announcement of this ETS (doa):	28 February 1996
Date of latest publication of new National Standard or endorsement of this ETS (dop/e):	31 August 1996
Date of withdrawal of any conflicting National Standard (dow):	31 August 1996

Blank page

1 Scope

This European Telecommunication Standard (ETS) is an introduction to GSM 06.20 (ETS 300 581-2) [4], GSM 06.21 (ETS 300 581-3) [5], GSM 06.22 (ETS 300 581-4) [6], GSM 06.41 (ETS 300 581-5) [7] and GSM 06.42 (ETS 300 581-6) [8] ETSs dealing with the speech processing functions in the half-rate channel of the GSM system. A general overview of the speech processing functions is given, with reference to the ETSs where each function is specified in detail.

2 Normative references

This ETS incorporates by dated and undated reference, provisions from other publications. These normative references are cited at the appropriate places in the text and the publications are listed hereafter. For dated references, subsequent amendments to or revisions of any of these publications apply to this ETS only when incorporated in it by amendment or revision. For undated references, the latest edition of the publication referred to applies.

- [1] GSM 01.04 (ETR 100): "European digital cellular telecommunication system (Phase 2); Abbreviations and acronyms".
- [2] GSM 03.50 (ETS 300 540): "European digital cellular telecommunication system (Phase 2); Transmission planning aspects of the speech services in the GSM Public Land Mobile Network (PLMN) system".
- [3] GSM 05.03 (ETS 300 575): "European digital cellular telecommunications system (phase 2); Channel coding".
- [4] GSM 06.20 (ETS 300 581-2): "European digital cellular telecommunications system; Half rate speech Part 2: Half rate speech transcoding".
- [5] GSM 06.21 (ETS 300 581-3): " European digital cellular telecommunications system; Half rate speech Part 3: Substitution and muting of lost frame for half rate speech traffic channels".
- [6] GSM 06.22 (ETS 300 581-4): "European digital cellular telecommunications system; Half rate speech Part 4: Comfort noise aspects for half rate speech traffic channels ".
- [7] GSM 06.41 (ETS 300 581-5): "European digital cellular telecommunications system; Half rate speech Part 5: Discontinuous transmission (DTX) for half rate speech traffic channels".
- [8] GSM 06.42 (ETS 300 581-6): "European digital cellular telecommunications system; Half rate speech Part 6: Voice Activity Detector (VAD) for half rate speech traffic channels ".
- [9] ITU-T Recommendation G.711: "Pulse Code Modulation (PCM) of voice frequencies".
- [10] GSM 06.07 (ETS 300 581-8): "European digital cellular telecommunications system; Half rate speech Part 8: Test vectors for the GSM half rate speech codec".
- [11] GSM 06.06 (ETS 300 581-7): "European digital cellular telecommunications system; Half rate speech Part 7: ANSI-C code for the GSM half rate speech codec".

3 Definitions and abbreviations

3.1 Definitions

Definition of terms used in this ETS can be found in GSM 06.20 (ETS 300 581-2) [4], GSM 06.21 (ETS 300 581-3) [5], GSM 06.22 (ETS 300 581-4) [6], GSM 06.41 (ETS 300 581-5) [7] and GSM 06.42 (ETS 300 581-6) [8].

3.2 Abbreviations

For the purpose of this ETS the following abbreviations apply.

BFI	Bad Frame Indication
BSS	Base Station System
DTX	Discontinuous Transmission
ETS	European Telecommunication Standard
GSM	Global System for Mobile communications
ITU-T	International Telecommunications Union - Telecommunication standardization sector
MS	Mobile Station
PCM	Pulse Code Modulated
PLMN	Public Land Mobile Network
PSTN	Public Switched Telephone Network
RF	Radio Frequency
RX	Receive
RSS	Radio SubSystem
SACCH	Slow Associated Control CHannel
SID	SIlence Descriptor
SP flag	SPeech flag
TAF	Time Alignment Flag
TX	Transmit
VSELP	Vector Sum Excited Linear Predictor
UFI	Unreliable Frame Indication

For abbreviations not given in this subclause see GSM 01.04 (ETR 100) [1].

4 General

Figure 1 presents a reference configuration where the various speech processing functions are identified. In this figure, the relevant ETSs for each function are also indicated.

In figure 1, the audio parts including analogue to digital and digital to analogue conversion are included, to show the complete speech path between the audio input/output in the Mobile Station (MS) and the digital interface of the PSTN. The detailed specification of the audio parts are contained in GSM 03.50 (ETS 300 540) [2]. These aspects are only considered to the extent that the performance of the audio parts affect the performance of the speech transcoder .

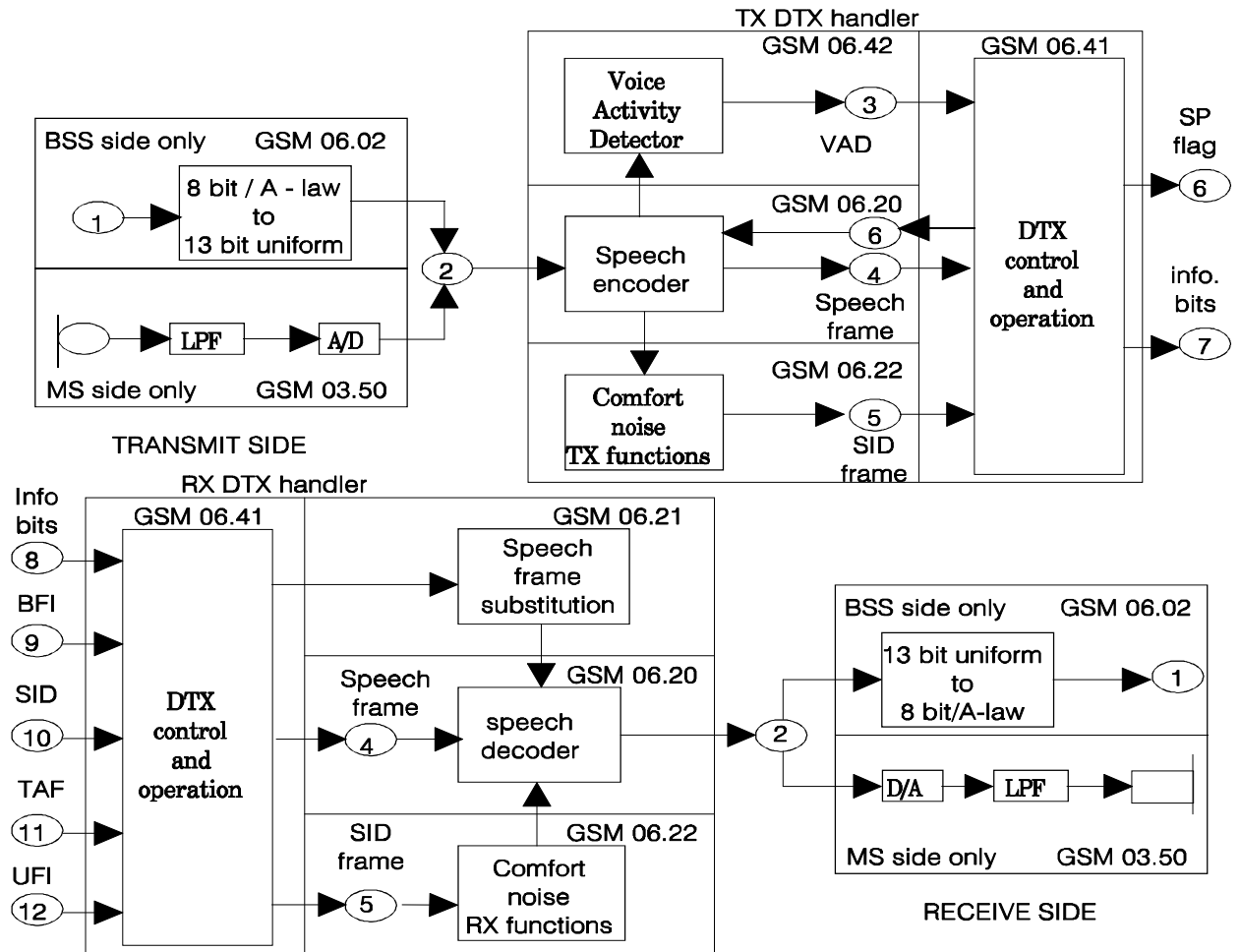

- 1 8 bit /A-law PCM (ITU-T Recommendation G.711) [9], 8 000 samples/s.
- 2 13 bit uniform PCM, 8 000 samples/s.
- 3 Voice Activity Detector (VAD) flag.
- 4 Encoded speech frame, 50 frames/s, 112 bits/frame.
- 5 Silence Descriptor (SID) frame, 112 bits/frame.
- 6 SPeech (SP) flag, indicates whether information bits are speech or SID information.
- 7 Information bits delivered to the radio subsystem.
- 8 Information bits received from the radio subsystem.
- 9 Bad Frame Indication (BFI) flag.
- 10 Silence Descriptor (SID) flag.
- 11 Time Alignment Flag (TAF), marks the position of the SID frame within the Slow Associated Control CHannel (SACCH) multiframe.
- 12 Unreliable Frame Indication (UFI).

Figure 1: Overview of audio processing functions

5 Half rate speech transcoding

The half rate speech transcoding function is described in GSM 06.20 (ETS 300 581-2) [4].

As shown in figure 1, the speech encoder takes its input as a 13 bit uniform Pulse Code Modulated (PCM) signal either from the audio part of the MS or on the network side, from the Public Switched Telephone Network (PSTN) via an 8 bit/A-law to 13 bit uniform PCM conversion. The encoded speech at the output of the speech encoder is delivered to the channel coding function as defined in GSM 05.03 (ETS 300 575) [3] to produce an encoded block consisting of 228 bits leading to a gross bit rate of 11,4 kbit/s.

In the RX direction, the inverse operations take place.

GSM 06.20 (ETS 300 581-2) [4] describes the detailed mapping between input blocks of 160 speech samples in 13 bit uniform PCM format into encoded blocks of 112 bits and from encoded blocks of 112 bits to output blocks of 160 reconstructed speech samples. The sampling rate is 8 000 sample/s leading to an average bit rate for the encoded bit stream of 5,6 kbit/s. The coding scheme is called Vector Sum Excited Linear Prediction (VSELP) coding.

GSM 06.20 (ETS 300 581-2) [4] describes the codec and GSM 06.06 [GSM 300 581-7 [11] defines the C code, thus enabling the verification of compliance to GSM 06.20 (ETS 300 581-2) [4] to a high degree of confidence by use of a set of digital test sequences given in GSM 06.07 (ETS 300 581-8) [10].

6 Half rate Discontinuous Transmission (DTX)

The half rate discontinuous transmission function is described in GSM 06.41 (ETS 300 581-5) [7].

During a normal conversation, the participants alternate so that, on the average, each direction of transmission is occupied about 50 % of the time. Discontinuous Transmission (DTX) is a mode of operation where the transmitters are switched on only for those frames which contain useful information. This may be done for the following two purposes:

- 1) In the MS, battery life will be prolonged or a smaller battery could be used for a given operational duration.
- 2) The average interference level over the air interface is reduced, leading to better Radio Frequency (RF) spectrum efficiency.

The overall DTX mechanism is implemented in the DTX handlers (Transmit (TX) and Receive (RX)) described in GSM 06.41 (ETS 300 581-5) [7] and requires the following functions:

- a Voice Activity Detector (VAD) on the TX side, see GSM 06.42 (ETS 300 581-6) [8];
- evaluation of the background acoustic noise on the TX side, in order to transmit characteristic parameters to the RX side, see GSM 06.22 (ETS 300 581-4) [6];
- generation of comfort noise on the RX side during periods where the radio transmission is turned off, see GSM 06.22 (ETS 300 581-4) [6].

The transmission of comfort noise information to the RX side is achieved by means of a Silence Descriptor (SID) frame. The SID frame is transmitted at the end of speech bursts and serves as an end of speech marker for the RX side. In order to update the comfort noise characteristics at the RX side, SID frames are transmitted at regular intervals also during speech pauses. This also serves the purpose of improving the measurement of the radio link quality by the Radio SubSystem (RSS).

The DTX handlers interwork with the RSS using flags. The RSS is controlled by the transmitter keying on the TX side, which performs pre-processing functions on the RX side. This is described in GSM 06.41 (ETS 300 581-5) [7].

The speech flag (SP) indicates whether information bits are speech or SID information. The SP flag is calculated from the VAD flag by the TX DTX handler. When SID information is transmitted (SP="0") the operation of the speech encoder is modified to reduce the remaining computation for that frame. This is described in GSM 06.22 (ETS 300 581-4) [6].

7 Half rate Voice Activity Detection (VAD)

The half rate VAD function is described in GSM 06.42 (ETS 300 581-6) [8].

The input to the VAD is a set of parameters computed by the half-rate speech encoder defined in GSM 06.20 (ETS 300 581-2) [4]. The VAD uses this information to decide whether each 20 ms speech coder frame contains speech or not.

NOTE: The VAD flag is an input to TX DTX handler and does not control the transmitter keying directly.

GSM 06.42 (ETS 300 581-6) [8] describes the VAD algorithm and GSM 06.06 (GSM 300 581-7) [11] defines the C code. The verification of compliance to GSM 06.42 (ETS 300 581-6) [8] is achieved by use of digital test sequences (see GSM 06.07 (ETS 300 581-8) [10]) applied to the same interface as the test sequences for the speech codec.

8 Half rate comfort noise insertion

The half rate noise comfort insertion function is described in GSM 06.22 (ETS 300 581-4) [6].

When switching the transmission on and off during DTX operation, the effect would be a modulation of the background noise at the receiving end, if no precautions were taken. When transmission is on, the background noise is transmitted together with the speech to the receiving end. As the speech burst ends, the connection is off and the perceived noise would drop to a very low level. This step modulation of noise may be perceived as annoying and reduce the intelligibility of speech, if presented to a listener without modification.

This "noise contrast effect" is reduced in the GSM system by inserting an artificial noise, termed comfort noise, at the receiving end when speech is absent.

The comfort noise processes are as follows:

- the evaluation of the acoustic background noise in the transmitter;
- the noise parameter encoding (SID frames) and decoding;
- and the generation of comfort noise in the receiver.

The comfort noise processes and the algorithm for updating the noise parameters during speech pauses are defined in detail in GSM 06.22 (ETS 300 581-4) [6].

The comfort noise mechanism is based on the half rate speech codec defined in GSM 06.20 (ETS 300 581-2) [4].

9 Half rate lost speech frame substitution and muting

The half rate speech frame substitution and muting function is described in GSM 06.21 (ETS 300 581-3) [5].

In the receiver, frames may be lost due to transmission errors or frame stealing. GSM 06.21 (ETS 300 581-3) [5] describes the actions to be taken in these cases, both for lost speech frames and for lost SID frames in DTX operation.

In order to mask the effect of an isolated lost frame, the lost speech frame is substituted by a predicted frame based on previous frames. Insertion of silence frames is not allowed. For several subsequent lost frames, a muting technique shall be used to indicate to the listener that transmission has been interrupted.

10 Half rate codec homing

The GSM half rate speech transcoder, VAD, DTX system and comfort noise parts of the audio processing functions (see figure 1) are defined in bit exact arithmetic. Consequently, they shall react on a given input sequence always with the corresponding bit exact output sequence, provided that the internal state variables are also always exact in the same state at the beginning of the experiment.

The input test sequences provided in GSM 06.07 (ETS 300 581-8) [10] shall force the corresponding output test sequences, provided that the tested modules are in their home-state when starting.

The modules may be set into their home states by provoking the appropriate homing-functions.

NOTE: This is normally done during reset.

Special inband signalling frames (encoder-homing-frame and decoder-homing-frame described in GSM 06.20 (ETS 300 581-2) [4] have been defined to provoke these homing-functions also in remotely placed modules.

This mechanism is specified to support three main areas:

- type approval of mobile terminal equipment;
- type approval of infrastructure equipment;
- remote control and testing for operation and maintenance..

At the end of the first received homing frame, the audio functions that are defined in a bit exact way shall go into their predefined home states. The output corresponding to the first homing frame is dependent on the codec state when the frame was received. Any consecutive homing frames shall produce corresponding homing frames at the output.

History

Document history			
March 1995	Public Enquiry	PE 80:	1995-03-06 to 1995-06-30
August 1995	Vote	V 86: extended:	1995-08-21 to 1995-10-13 1995-08-21 to 1995-10-27
November 1995	First Edition		