



EUROPEAN
TELECOMMUNICATION
STANDARD

ETS 300 338

November 1995

Source: ETSI TC-RES

Reference: DE/RES-01-05

ICS: 33.020

Key words: radiotelephony, maritime radio, GMDSS, DSC systems

**Radio Equipment and Systems (RES);
Technical characteristics and methods of measurement for
equipment for generation, transmission and reception of Digital
Selective Calling (DSC) in the maritime MF, MF/HF and/or VHF
mobile service**

ETSI

European Telecommunications Standards Institute

ETSI Secretariat

Postal address: F-06921 Sophia Antipolis CEDEX - FRANCE

Office address: 650 Route des Lucioles - Sophia Antipolis - Valbonne - FRANCE

X.400: c=fr, a=atlas, p=etsi, s=secretariat - **Internet:** secretariat@etsi.fr

Tel.: +33 92 94 42 00 - Fax: +33 93 65 47 16

Copyright Notification: No part may be reproduced except as authorized by written permission. The copyright and the foregoing restriction extend to reproduction in all media.

© European Telecommunications Standards Institute 1995. All rights reserved.

Contents

Foreword	9
1 Scope	11
2 Normative references	11
3 General requirements	12
3.1 Construction	12
3.1.1 General	12
3.1.2 DSC signals input/output: analogue signals	12
3.1.3 DSC signals input/output: digital signals	13
3.1.4 Decoding	13
3.1.5 Accessibility	13
3.1.6 Calibration	13
3.1.7 Selection of signal characteristics	13
3.1.8 Reduction of power for VHF equipment	13
3.1.9 VHF channel 70 access	13
3.1.10 Automatic/semi-automatic service	13
3.2 Switching time	13
3.3 Frequencies	13
3.4 Classes of emission	14
3.5 Controls and indicators	14
3.5.1 General	14
3.5.2 Input panel	14
3.5.3 Light sources	14
3.5.4 Operation	14
3.5.5 Markings	15
3.5.6 Distress function	15
3.6 Facilities for equipment for coding and decoding of DSC	15
3.6.1 Composition of calls	15
3.6.2 Visual indication	15
3.6.3 Ship's identity	15
3.6.4 Entry of information	15
3.6.5 Insertion of sequence codes	16
3.6.6 Insertion of error check character	16
3.6.7 Distress call	16
3.6.8 Remote control	16
3.6.9 Single frequency distress call	16
3.6.10 Multi-frequency distress call	16
3.6.11 Distress call acknowledgement	16
3.6.12 Incoming calls	16
3.6.13 Internal memory	16
3.6.14 Automatic acknowledgement	17
3.6.15 Routine testing	17
3.7 Alarm circuits	17
3.7.1 Distress and urgency	17
3.7.2 Other categories	17
3.8 Interfaces between DSC equipment and external circuits	17
3.8.1 Remote alarms	17
3.8.2 Operational interfaces	17
3.8.3 Printer output	17
3.8.4 Other interfaces	18
3.9 Safety precautions	18
3.9.1 Excessive current and voltage	18
3.9.2 Protection	18
3.9.3 Earthing	18
3.9.4 Access	18

	3.9.5	Memory	18	
3.10		Compass safe distance.....	18	
3.11		Instructions.....	18	
3.12		Warming-up period	19	
	3.12.1	Time.....	19	
	3.12.2	Heaters	19	
	3.12.3	Heating circuits	19	
4		Test conditions.....	19	
4.1		General.....	19	
4.2		Generation and examination of the digital selective call signal	19	
4.3		Standard test signals.....	19	
	4.3.1	References to standard test signals	19	
	4.3.2	Standard test signal no. 1	19	
	4.3.3	Standard test signal no. 2	20	
	4.3.4	Standard test signal no. 3	20	
	4.3.5	Standard test signal no. 4	20	
4.4		Determination of the symbol error rate in the output of the receiving part	20	
4.5		Impedance of test signal sources.....	20	
	4.5.1	Equipment ports.....	20	
	4.5.2	Impedances	21	
		4.5.2.1 Non-integrated equipment	21	
4.6		Connection of test signals	21	
4.7		Test power source.....	21	
4.8		Internally generated signals	22	
4.9		Normal test conditions.....	22	
	4.9.1	Normal temperature and humidity	22	
	4.9.2	Normal test power source.....	22	
		4.9.2.1 Mains voltage and mains frequency.....	22	
		4.9.2.2 Secondary battery power source	22	
		4.9.2.3 Other power sources.....	22	
4.10		Extreme test conditions.....	22	
	4.10.1	Temperatures when testing under extreme conditions.....	22	
	4.10.2	Procedures of tests at extreme temperatures	22	
	4.10.3	Extreme values of test power source	23	
		4.10.3.1 Mains voltage and mains frequency.....	23	
		4.10.3.2 Secondary battery power sources.....	23	
		4.10.3.3 Other power sources.....	23	
4.11		Environmental tests.....	23	
	4.11.1	Introduction	23	
	4.11.2	Procedure	23	
	4.11.3	Performance check.....	23	
	4.11.4	Vibration test.....	24	
		4.11.4.1 Method of measurement	24	
		4.11.4.2 Requirement	25	
	4.11.5	Temperature tests	25	
		4.11.5.1 Dry heat for externally mounted equipment	25	
			4.11.5.1.1 Method of measurement	25
			4.11.5.1.2 Requirement.....	25
		4.11.5.2 Damp heat cycle	25	
			4.11.5.2.1 Method of measurement	25
			4.11.5.2.2 Requirement.....	26
		4.11.5.3 Low temperature cycle for externally mounted equipment	26	
			4.11.5.3.1 Method of measurement	26
			4.11.5.3.2 Requirement.....	26
	4.11.6	Corrosion test	26	
		4.11.6.1 General	26	
		4.11.6.2 Method of measurement	26	
		4.11.6.3 Requirements.....	27	
	4.11.7	Rain test.....	27	
		4.11.7.1 General	27	
		4.11.7.2 Method of measurement	27	
		4.11.7.3 Requirements.....	28	

4.12	Measurement uncertainty and interpretation of the measuring results.....	28
4.12.1	Measurement uncertainty.....	28
4.12.2	Interpretation of measurement results	29
5	MF/HF transmitter with integrated DSC encoder	29
5.1	Frequency error	29
5.1.1	Definition	29
5.1.2	Method of measurement	29
5.1.3	Limits	29
5.2	RF output power	29
5.2.1	Definition	29
5.2.2	Method of measurement	29
5.2.3	Limits	29
5.3	Modulation rate	30
5.3.1	Definition	30
5.3.2	Method of measurement	30
5.3.3	Limits	30
5.4	Residual modulation of the transmitter	30
5.4.1	Definition	30
5.4.2	Method of measurement	30
5.4.3	Limits	30
5.5	Unwanted emission.....	30
5.5.1	Definition	30
5.5.2	Method of measurement	31
5.5.3	Limits	31
5.6	Testing of generated call sequences	32
5.7	Tuning time	32
5.8	Protection of transmitter.....	33
5.8.1	Definition	33
5.8.2	Method of measurement	33
5.8.3	Limits	33
6	VHF transmitter with integrated DSC encoder	33
6.1	Frequency error (carrier).....	33
6.1.1	Definition	33
6.1.2	Method of measurement	33
6.1.3	Limits	33
6.2	Frequency error (demodulated signal).....	33
6.2.1	Definition	33
6.2.2	Method of measurement	33
6.2.3	Limits	34
6.3	Carrier power	34
6.3.1	Definition	34
6.3.2	Method of measurement	34
6.3.3	Limits	34
	6.3.3.1 Normal test conditions	34
	6.3.3.2 Extreme test conditions	34
6.4	Modulation index.....	34
6.4.1	Definition	34
6.4.2	Method of measurement	34
6.4.3	Limits	34
6.5	Modulation rate	35
6.5.1	Definition	35
6.5.2	Method of measurement	35
6.5.3	Limits	35
6.6	Residual modulation of the transmitter	35
6.6.1	Definition	35
6.6.2	Method of measurement	35
6.6.3	Limits	35
6.7	Adjacent channel power.....	35
6.7.1	Definition	35
6.7.2	Measurement	35
	6.7.2.1 Method of measurement.....	35

	6.7.3	Limits	36
6.8		Conducted spurious emissions conveyed to the antenna	36
	6.8.1	Definition	36
	6.8.2	Method of measurement	36
	6.8.3	Limit	36
6.9		Testing of generated call sequences	37
6.10		Transient frequency behaviour of the transmitter	37
	6.10.1	Definitions	37
	6.10.2	Method of measurement	38
7		MF/HF DSC encoder	41
	7.1	Frequency error	41
		7.1.1 Definition	41
		7.1.2 Method of measurement	41
		7.1.3 Limits	41
	7.2	Output voltage	41
		7.2.1 Definition	41
		7.2.2 Method of measurement	41
		7.2.3 Limits	41
		7.2.3.1 Analogue voltage	41
		7.2.3.2 Binary voltage	41
	7.3	Bit stream speed	41
		7.3.1 Definition	41
		7.3.2 Method of measurement	41
		7.3.3 Limits	42
	7.4	Unwanted spectral components of the output signal	42
		7.4.1 Definition	42
		7.4.2 Method of measurement	42
		7.4.3 Limits	42
	7.5	Testing of generated call sequences	43
	7.6	Residual frequency modulation	43
		7.6.1 Definition	43
		7.6.2 Method of measurement	43
		7.6.3 Limits	43
8		VHF DSC encoder	43
	8.1	Frequency error	43
		8.1.1 Definition	43
		8.1.2 Method of measurements	43
		8.1.3 Limits	43
	8.2	Output voltage	44
		8.2.1 Definition	44
		8.2.2 Method of measurement	44
		8.2.3 Limits	44
		8.2.3.1 Analogue voltage	44
		8.2.3.2 Binary voltage	44
	8.3	Bit stream speed	44
		8.3.1 Definition	44
		8.3.2 Method of measurement	44
		8.3.3 Limits	44
	8.4	Unwanted spectral components of the output signal	44
		8.4.1 Definition	44
		8.4.2 Method of measurement	44
		8.4.3 Limits	45
	8.5	Testing of generated call sequences	45
	8.6	Residual frequency modulation	45
		8.6.1 Definition	45
		8.6.2 Method of measurement	45
		8.6.3 Limits	46
9		MF/HF receiver with integrated DSC decoder	46
	9.1	Scanning watch receiver efficiency	46
		9.1.1 Definition	46

	9.1.2	Method of measurement	46
	9.1.3	Limits	46
9.2		Calling sensitivity	46
	9.2.1	Definition	46
	9.2.2	Method of measurement	46
	9.2.3	Limits	47
9.3		Adjacent channel selectivity	47
	9.3.1	Definition	47
	9.3.2	Method of measurement	47
	9.3.3	Limits	47
9.4		Co-channel rejection	47
	9.4.1	Definition	47
	9.4.2	Method of measurements	47
	9.4.3	Limits	48
9.5		RF intermodulation response.....	48
	9.5.1	Definition	48
	9.5.2	Method of measurement	48
	9.5.3	Limits	48
9.6		Interference rejection and blocking immunity	48
	9.6.1	Definition	48
	9.6.2	Method of measurement	48
	9.6.3	Limits	48
9.7		Dynamic range.....	49
	9.7.1	Definition	49
	9.7.2	Method of measurement	49
	9.7.3	Limits	49
9.8		Conducted spurious emissions.....	49
	9.8.1	Definition	49
	9.8.2	Method of measurement	49
	9.8.3	Limits	49
9.9		Verification of correct decoding of various types of digital selective calls.....	49
9.10		Protection of receiver antenna input circuits.....	50
10		VHF receiver with integrated DSC decoder	50
	10.1	Maximum usable sensitivity	50
		10.1.1 Definition	50
		10.1.2 Method of measurement	50
		10.1.3 Limits	50
	10.2	Co-channel rejection.....	50
		10.2.1 Definition	50
		10.2.2 Method of measurement	50
		10.2.3 Limits	51
	10.3	Adjacent channel selectivity.....	51
		10.3.1 Definition	51
		10.3.2 Method of measurement	51
		10.3.3 Limits	51
	10.4	Spurious response and blocking immunity	51
		10.4.1 Definition	51
		10.4.2 Method of measurement	51
		10.4.3 Limits	52
	10.5	Intermodulation response	52
		10.5.1 Definition	52
		10.5.2 Method of measurement	52
		10.5.3 Limits	52
	10.6	Dynamic range.....	52
		10.6.1 Definition	52
		10.6.2 Method of measurement	52
		10.6.3 Limit.....	52
	10.7	Conducted spurious emissions.....	53
		10.7.1 Definition	53
		10.7.2 Method of measurement	53
		10.7.3 Limit.....	53
	10.8	Verification of correct decoding of various types of digital selective calls.....	53

11	MF/HF DSC decoder	53
11.1	Interface for scanning.....	53
11.2	Scanning efficiency	54
11.2.1	Definition.....	54
11.2.2	Method of measurement.....	54
11.2.3	Limits	54
11.3	Dynamic range	54
11.3.1	Definition.....	54
11.3.2	Method of measurement.....	54
11.3.2.1	Analogue voltage	54
11.3.2.2	Binary voltage.....	54
11.3.3	Limits	55
11.4	Verification of correct decoding of various types of digital selective calls	55
12	VHF DSC decoder	55
12.1	Dynamic range	55
12.1.1	Definition.....	55
12.1.2	Method of measurement.....	55
12.1.2.1	Analogue voltage	55
12.1.2.2	Binary voltage.....	55
12.1.3	Limits	56
12.2	Verification of correct decoding of various types of digital selective calls	56
Annex A (normative): Test calls.....		57
A.1	Types of calls to be tested.....	57
A.2	Telecommands applicable to DSC shipborne equipment	58
A.2.1	Class A, MF/HF equipment	58
A.2.2	Class A, VHF equipment.....	58
A.2.3	Class B, MF equipment.....	58
A.2.4	Class B, VHF equipment.....	58
A.2.5	Class D.....	58
A.2.6	Class E	58
A.2.7	Class F	58
A.2.8	Class G.....	58
Annex B (normative): Specifications for adjacent channel power measurement arrangements.....		59
B.1	Power measuring receiver specification	59
B.1.1	IF filter	59
B.1.2	Attenuation indicator.....	60
B.1.3	Rms value indicator.....	60
B.1.4	Oscillator and amplifier.....	60
History.....		61

Foreword

This European Telecommunications Standard (ETS) has been produced by the Radio Equipment and Systems (RES) Technical Committee of the European Telecommunications Standards Institute (ETSI).

Transposition dates	
Date of adoption of this ETS:	29 September 1995
Date of latest announcement of this ETS (doa):	28 February 1996
Date of latest publication of new National Standard or endorsement of this ETS (dop/e):	31 August 1996
Date of withdrawal of any conflicting National Standard (dow):	31 August 1996

Every ETS prepared by ETSI is a voluntary standard. This ETS may contain text concerning conformance testing of the equipment to which it relates. This text should be considered as guidance only and does not make this ETS mandatory.

Blank page

1 Scope

This European Telecommunication Standard (ETS) states the minimum requirements for equipment to be used for generation, transmission and reception of Digital Selective Calling (DSC) for use on board ships.

DSC may be used in the Medium Frequency (MF), High Frequency (HF) and Very High Frequency (VHF) Maritime Mobile Service (MMS), both in connection with distress and safety communication and in connection with public correspondence.

This ETS covers the requirements to be fulfilled by:

- DSC equipment integrated with a transmitter and/or a receiver;
- DSC equipment not integrated with a transmitter and/or a receiver.

These requirements include the relevant provisions of the ITU Radio Regulations [1] and ITU-R recommendations, the International Convention for the Safety Of Life At Sea (SOLAS) [3], and the relevant resolutions of the International Maritime Organization (IMO).

Equipment for generation, transmission and reception of DSC is recommended to be designed according to following equipment classes:

- Class A - includes all the facilities defined in Annex 1 of ITU-R Recommendation M.493-6 [4];
- Class B - provides minimum facilities for equipment on ships not required to use Class A equipment and complies with the minimum IMO Global Maritime DistreSS (GMDSS) carriage requirements for MF and/or VHF installations. This equipment should provide for:
 - alerting, acknowledgement and relay facilities for distress purposes;
 - calling and acknowledgement for general communication purposes; and
 - calling in connection with semi-automatic/automatic services, as defined in ITU-R Recommendation M.493-6 [4], Annex 2, subclause 3;
- Class D - provides minimum facilities for VHF DSC distress, urgency and safety as well as routine calling and reception, not necessarily in full accordance with IMO GMDSS carriage requirements for VHF installations;
- Class E - provides minimum facilities for MF and/or HF DSC distress, urgency and safety as well as routine calling and reception, not necessarily in full accordance with IMO GMDSS carriage requirements for MF/HF installations;
- Class F - provides for VHF DSC distress, urgency and safety calling and also for reception of acknowledge to its own distress calls (in order to terminate the transmission);
- Class G - provides for MF DSC distress, urgency and safety calling and also for reception of acknowledge to its own distress calls (in order to terminate the transmission).

2 Normative references

This ETS incorporates by dated or undated reference provisions from other publications. These normative references are cited at the appropriate places in the text and the publications are listed hereafter. For dated references, subsequent references to or revisions of any of these publications apply to this ETS only when incorporated in it by amendment or revision. For undated references the latest edition of the publication referred to applies.

[1] ITU Radio Regulations.

[2] ITU-T Recommendation E.161 (1988): "Arrangement of digits, letters and symbols on telephones and other devices that can be used for gaining access to a telephone network".

- [3] International Convention for the Safety of Life at Sea (1974) as amended in 1988.
- [4] ITU-R Recommendation M.493-6: "Digital selective-calling system for use in the maritime mobile service".
- [5] ITU-R Recommendation M.541-5: "Operational procedures for the use of digital selective-calling (DSC) equipment in the maritime mobile service".
- [6] ITU-R Recommendation M.689-2: "Operational procedures for an international maritime VHF radiotelephone system with automatic facilities based on DSC signalling format".
- [7] NMEA 0183, Version 2.00: "Standard for interfacing marine electronic devices".
- [8] ITU-R Recommendation SM.332-4: "Selectivity of receivers".
- [9] ISO Standard 3791: "Office machines and data processing equipment - Keyboard layouts for numeric applications".
- [10] IEC Recommendation 529: "Degrees of protection provided by enclosures (IP code)".
- [11] ETR 028: "Radio Equipment and Systems (RES); Uncertainties in the measurement of mobile radio equipment characteristics".
- [12] ITU-T Recommendation V.11: "Electrical characteristics for balanced double-current interchange circuits operating at data signalling rates up to 10 Mbit/s".
- [13] ITU-R Recommendation M.1082: "International maritime MF/HF radiotelephone system with automatic facilities based on DSC signalling format".

3 General requirements

3.1 Construction

3.1.1 General

The equipment shall comprise the necessary facilities for coding and transmission of DSC and for decoding and conversion of the information content of received DSC to visual form in plain language.

The design and function of DSC equipment shall comply with the provisions of ITU-R Recommendation M.493-6 [4].

The equipment may be either;

- an independent unit for connection to an external radio installation designed for maritime radio communication; or
- mechanically and electrically integrated in such radio equipment.

The equipment shall be constructed in conformity with good engineering practice, both mechanically and electrically, and shall be suitable for use on-board ships.

If the DSC equipment is integrated into radio equipment the receiver part of the equipment shall be designed for continuous operation.

3.1.2 DSC signals input/output: analogue signals

If the equipment is designed as an independent DSC unit for connection to the audio frequency terminals of external radio equipment, the input and output impedances shall be 600 Ω free of earth.

3.1.3 DSC signals input/output: digital signals

If the equipment is designed as an independent DSC unit, with binary inputs and outputs for DSC, the logic level shall comply with ITU-T Recommendation V.11 [12].

3.1.4 Decoding

The DSC equipment shall be so designed that in the decoding process the greatest possible use is made of parity bits for error detection, time multiplex repetitions and error check characters in the received call (see ITU-R Recommendation M.493-6 [4], Annex I, subclause 1.6 and, if appropriate subclause 1.7.2).

3.1.5 Accessibility

All parts of the equipment which are subject to inspection and maintenance adjustments shall be easily accessible. Components shall be easily identifiable either by markings within the equipment, or with the aid of technical description.

3.1.6 Calibration

The equipment shall be so constructed that its main modules can easily be replaced and put into operation without elaborate calibration or re-adjustment.

3.1.7 Selection of signal characteristics

Equipment constructed for DSC to be used on frequencies both in the MF/HF range and in the maritime VHF band shall automatically select the signal characteristics relevant to the frequency range concerned (see ITU-R Recommendation M.493-6, [4] Annex I, subclauses 1.2 and 1.3).

3.1.8 Reduction of power for VHF equipment

Integrated VHF DSC equipment shall automatically reduce power (see subclause 6.3) for transmission of ships originated routine "all ships calls".

3.1.9 VHF channel 70 access

Equipment for transmission of DSC in the maritime VHF band shall be provided with facilities which, except for distress and safety calls, automatically prevents the transmission of DSC on channel 70 until the channel is free.

3.1.10 Automatic/semi-automatic service

Equipment designed for use in an automatic/semi-automatic VHF radiotelephone service using DSC shall comply with the provisions of ITU-R Recommendation M.689-2 [6].

Equipment designed for use in an automatic/semi-automatic MF/HF radiotelephone service using DSC shall comply with the provisions of ITU-R Recommendation M.1082 [13].

3.2 Switching time

For integrated equipment, the Radio Frequency (RF) channel switching arrangement shall be such that the time necessary to change from using one of the channels to using any other channel in the same band does not exceed 5 seconds.

For integrated equipment, the time necessary to change over from RF transmission to RF reception or vice versa, shall not exceed 0,3 seconds.

3.3 Frequencies

For integrated equipment, the RF equipment shall be capable of transmitting and/or receiving on one or more of the following frequencies:

- 2 187,5 kHz only;

- 4 207,5 kHz, 6 312 kHz, 8 414,5 kHz, 12 577 kHz and 16 804,5 kHz only;
- VHF channel 70 only.

In addition, the RF equipment may be capable of transmitting and/or receiving on frequencies from the following bands as permitted by the ITU Radio Regulations [1]:

- 415 kHz to 526,5 kHz;
- 1 606,5 kHz to 4 000 kHz;
- 4 MHz to 27,5 MHz;
- 156 MHz to 174 MHz.

3.4 Classes of emission

Integrated equipment used for MF/HF transmission and/or reception shall provide for the following classes of emission:

F1B Frequency Modulation (FM) with digital information, without a sub-carrier for automatic reception; or

J2B Single SideBand (SSB) with digital information, with the use of a modulating sub-carrier, with the carrier suppressed to at least 40 dB below peak envelope power.

Integrated equipment used for VHF transmission and/or reception shall provide for the following class of emission:

G2B Phase Modulation (PM) with digital information, with a sub-carrier for automatic reception.

3.5 Controls and indicators

3.5.1 General

The number of operational controls, their design and manner of functioning, location, arrangement and size should provide for simple, quick and efficient operation. The controls should be arranged in a manner which minimises the risk of inadvertent activation.

All operational controls shall be easy to be identified from the position at which the operator operates the equipment.

Controls which are not necessary for normal operation of the equipment shall not be readily accessible to the operator.

3.5.2 Input panel

Where a digital input panel with the digits "0" to "9" is provided, the digits shall be arranged to conform with ITU-T Recommendation E.161 [2]. However, where an alphanumeric keyboard layout is provided, the digits "0" to "9" may, alternatively, be arranged to conform with ISO Standard 3791 [9].

3.5.3 Light sources

If the equipment is provided with light sources for indication, illumination etc., the equipment shall be provided with a control by which the light from such sources can be reduced either continuously or in steps to the point of extinction.

3.5.4 Operation

The equipment shall be so designed that misuse of the controls cannot cause damage to the equipment or injury to personnel.

For integrated equipment means shall be provided to interrupt the transmissions and to reset the equipment manually.

3.5.5 Markings

All controls, instruments, indicators and terminals shall be clearly marked. Details of the power supply from which the equipment is intended to operate shall be clearly indicated. The type designation under which the equipment is submitted for conformance testing shall be marked on the equipment so as to be clearly visible in the normal operating position.

For integrated equipment the assigned frequency or channel to which the equipment is tuned shall be clearly indicated on the control panel of the equipment.

3.5.6 Distress function

A distress alert should be activated only by means of a dedicated distress button. This button should not be any key of a digital input panel or a keyboard provided on the equipment.

The distress button should be clearly identified and be protected against inadvertent operation.

The distress alert initiation should require at least two independent actions.

The equipment shall indicate the status of the distress alert transmission.

It shall be possible to interrupt and initiate distress alerts at any time.

3.6 Facilities for equipment for coding and decoding of DSC

3.6.1 Composition of calls

The facilities for coding and composition of calls in accordance with ITU-R Recommendations M.493-6 [4] and M.541-5 [5] shall be so arranged that it is possible for the operator quickly and precisely to enter a call (without using external aids, e.g. manuals, for converting the information contained in the call to the figure codes used in the signal format).

3.6.2 Visual indication

The equipment shall be provided with facilities for visual indication, inspection and possible manual correction of the information content of the call before the call is sent.

There shall be an indication on the DSC control panel showing when a message is being transmitted, and in addition an indication shall be provided showing the DSC encoder is in its automatic re-transmit mode.

There shall be an indication of the operational status as defined in ITU-R Recommendation M.541-5 [5].

Any visual display of the information content shall be clearly legible under all ambient light conditions.

3.6.3 Ship's identity

The equipment shall be capable of storing permanently the ship's 9-digit Maritime Mobile Service Identity (MMSI) number which shall be inserted automatically in the call. It shall not be possible to change the identity number, using any combination of operator controls.

3.6.4 Entry of information

Means shall be provided for manual entry of the geographical position information and of the time when this position information was valid. In addition, facilities for automatic entry and encoding of the geographical position and time information shall be provided. Such facilities shall conform with NMEA 0183, Version 2.0.0 [7].

3.6.5 Insertion of sequence codes

The end of sequence codes 117 (RQ), 122 (BQ), or 127 shall be inserted automatically as appropriate.

3.6.6 Insertion of error check character

When encoding of the information content of the call is finished, the final error check character shall be inserted automatically.

3.6.7 Distress call

The DSC equipment should be capable of being preset to initiate the transmission of a distress call on at least one distress alerting frequency in the associated RF equipment.

Initiation of a distress call shall automatically have priority over any other operation of the equipment.

3.6.8 Remote control

If the equipment can be operated from more than one position, the control unit provided at the position from where the ship is normally navigated shall have priority and the individual control units shall be provided with an indicator showing whether the equipment is in operation.

3.6.9 Single frequency distress call

When equipment is activated for transmitting a distress call attempt on a single frequency, the call shall automatically be transmitted five times in succession with no intervals between the individual calls so that bit synchronisation between the transmitter and receiver of the call can be maintained. Each call shall include the appropriate dot pattern.

3.6.10 Multi-frequency distress call

Equipment constructed for DSC on frequencies in the MF and/or the HF range may be provided with facilities for automatic transmission of a multi-frequency distress call attempt as up to 6 consecutive calls dispersed over a maximum of six distress frequencies (on distress and safety frequencies 2 187,5 kHz, 4 207,5 kHz, 6 312 kHz, 8 414,5 kHz, 12 577 kHz, and 16 804,5 kHz). Where such facilities are provided the equipment shall either:

- be capable of receiving DSC calls on all distress frequencies (except for the transmit frequency in use) whilst the distress call is being transmitted; or
- be able to complete the distress call attempt within one minute.

3.6.11 Distress call acknowledgement

Where no distress acknowledgement is received, the equipment shall automatically re-transmit the distress call attempt after a random delay of between 3,5 and 4,5 minutes from the beginning of the previous call.

This sequence shall be continued until a distress acknowledgement has been received, or until the automatic transmission of the distress call is discontinued manually.

Means shall be provided for transmitting the distress call attempt again by manual intervention at any time.

3.6.12 Incoming calls

The DSC equipment shall be provided with suitable facilities for converting incoming calls with relevant address content to visual form in plain language (see also subclauses 3.1.1 and 3.6.1).

3.6.13 Internal memory

DSC equipment not provided with a printer unit for immediate paper printout of the information content of the message received, shall contain an internal store with sufficient capacity for storing of at least 20

different received DSC distress calls and calls having distress category. Consecutive calls of a single frequency distress call attempt shall only be stored once.

The contents of the last received DSC messages shall remain stored until readout is initiated manually.

Received messages shall be stored or printed out even if the received Error Check Character (ECC) does not match. An ECC error should be clearly indicated when the information in the received symbols is displayed.

3.6.14 Automatic acknowledgement

The equipment may be provided with facilities for automatic transmission of acknowledgements except for distress acknowledgements and acknowledgements to calls having the distress category.

Automatic acknowledgement transmission shall not take place unless the ECC is received and decoded correctly.

3.6.15 Routine testing

Means shall be provided to enable routine testing of the DSC unit without activating the associated radio transmitter.

3.7 Alarm circuits

3.7.1 Distress and urgency

The equipment shall be provided with a specific acoustic alarm and a visual alarm, activated automatically when a call with format specifier distress or category distress or urgency has been received. The alarms shall remain in the activated condition until reset manually. It shall not be possible to disable these alarm circuits.

3.7.2 Other categories

The equipment shall be provided with an acoustic and a visual alarm, activated automatically on receipt of calls of categories other than those mentioned under subclause 3.7.1. Capability of disabling the acoustic alarm circuit may be provided.

3.8 Interfaces between DSC equipment and external circuits

3.8.1 Remote alarms

The equipment shall be provided with facilities for connecting remote alarms as described in subclause 3.7.

3.8.2 Operational interfaces

The equipment shall be provided with a suitable interface for the automatic provision of navigation, position determining and time (in Universal Time Co-ordinated(UTC)) information.

The equipment may also be provided with additional suitable interfaces. These may include the following:

- the control of any external transmitter and receiver associated with the DSC operation;
- the control of scanning receivers.

For independent units such interfaces, if provided, shall comply with NMEA 0183, Version 2.0.0 [7].

3.8.3 Printer output

The decoding part of the equipment may be provided with a printer or an output terminal for connecting an external printer. The electrical characteristics of the output shall be a parallel CENTRONICS type interface.

3.8.4 Other interfaces

The equipment may, in addition to the standardised interfaces, be provided with interfaces for the same functions, offering other electrical characteristics.

3.9 Safety precautions

3.9.1 Excessive current and voltage

Provision shall be made for protecting the equipment from the effects of excessive current or voltage and from excessive rise of temperature in any part of the equipment due to failure of the cooling system, if any.

3.9.2 Protection

Provision shall be made for protecting the equipment from damage if the power supply is subject to transient voltage changes and from damage due to the accidental reversal of the polarity of the power supply.

No connection of, or failure within, any external circuits shall disable the DSC equipment.

3.9.3 Earthing

Means shall be provided for earthing exposed metallic parts of the equipment, but the equipment shall not cause any terminal of the source of electrical energy to be earthed.

3.9.4 Access

All parts and wiring in which direct or alternating voltages, or both, (other than RF voltages) combine to give a peak voltage greater than 50 volts shall be protected against accidental access and shall be isolated automatically from all sources of electrical energy if the protective covers are removed.

Alternatively, the equipment shall be so constructed that access to such voltages can only be gained after having used a tool for this purpose (e.g. a spanner or screwdriver). In this case, warning labels shall be prominently displayed both within the equipment and on protective covers.

3.9.5 Memory

The information in programmable memory devices shall be protected from interruptions in the power supply of at least 10 hours duration. The ship's identity and information inherent to the DSC process shall be stored in non-volatile memory devices.

3.10 Compass safe distance

The compass safe distance to standard, and steering, magnetic compasses shall be stated on the equipment or in the manual.

3.11 Instructions

Adequately detailed operation and maintenance instructions shall be provided with the equipment.

If the equipment is so constructed that fault diagnosis and repair is practicable down to component level, the instructions shall include full circuit diagrams, component layouts and components parts lists.

If the equipment contains modules in which fault diagnosis and repair down to component level is not practicable, the instructions shall contain sufficient information to enable localisation and replacement of the defective module. With regard to other modules and components in the equipment, the instructions shall contain the information mentioned above.

3.12 Warming-up period

3.12.1 Time

The equipment shall be operational and shall meet the requirements of this ETS within one minute after switching on, except as provided in subclause 3.12.2.

3.12.2 Heaters

If the equipment includes parts which require to be heated in order to operate correctly, e.g. crystal ovens, then a warming-up period of 30 minutes from the instant of application of power to those parts shall be allowed, after which the requirements of this ETS shall be met.

3.12.3 Heating circuits

Where subclause 3.12.2 is applicable, the power supplies to the heating circuits shall be arranged so that they can remain operative when other supplies to the equipment, or within the equipment, are switched off. If a special switch for these circuits is provided on the equipment, the function of the switch shall be clearly indicated and the operating instructions shall state that the circuit should normally be left connected to the supply voltage. A visual indication that power is connected to such circuits shall be provided on the front panel.

4 Test conditions

4.1 General

The conformance tests in this ETS shall be made under normal test conditions and also, where stated, under extreme test conditions.

4.2 Generation and examination of the digital selective call signal

During the conformance tests the DSC signals generated by the equipment shall be examined by means of calibrated apparatus for decoding and printing out the information content of the signals.

The decoding part of the equipment may be provided with a printer or an output terminal for connecting an external printer.

The equipment delivered for the purposes of testing shall be provided with a printer or an output terminal for connecting a printer or computer for registration of the decoded call sequences. Details concerning such output signals to an external printer or computer shall be agreed between the manufacturer and the testing laboratory.

The facilities of the equipment for reception and/or decoding of DSC shall be examined by feeding DSC signals from a calibrated DSC generator.

4.3 Standard test signals

4.3.1 References to standard test signals

Standard test signals consist of a series of identical call sequences, each of which contains a known number of information symbols (format specifier, address, category, identification etc. of ITU-R Recommendation M.493-6 [4] subclause 1.5). See also subclause 4.4.

Standard test signals should be of sufficient length for the measurements to be performed or it should be possible to repeat them without interruption to make the measurements.

4.3.2 Standard test signal no. 1

Standard test signal no. 1 for MF/HF DSC decoder shall be a signal at the nominal receiver frequency with a frequency shift of ± 85 Hz and capable of being modulated with a modulation rate of 100 bit/s with various types of digital selective calls generated by the calibrated apparatus. When testing non-integrated equipment, the standard test signal no. 1 shall have a nominal frequency of 1 700 Hz.

4.3.3 Standard test signal no. 2

Standard test signal no. 2 for MF/HF DSC decoder operating with binary signals shall have logic levels complying with ITU-T Recommendation V.11 [12] and shall be modulated with a modulation rate of 100 bit/s with various types of digital selective calls generated by the calibrated apparatus.

4.3.4 Standard test signal no. 3

Standard test signal no. 3 for VHF DSC decoder shall be a phase-modulated signal at VHF channel 70 with modulation index = 2. The modulating signal shall have a nominal frequency of 1 700 Hz and a frequency shift of ± 400 Hz. For non-integrated equipment, the standard test signal no. 3 shall be the modulating signal only.

4.3.5 Standard test signal no. 4

Standard test signal no. 4 for VHF DSC decoder operating with binary signals shall have logic levels complying with ITU-T Recommendation V.11 [12] and be modulated with a modulation rate of 1 200 bit/s with various types of digital selective calls generated by the calibrated apparatus.

4.4 Determination of the symbol error rate in the output of the receiving part

The information content of the decoded call sequence to which forward error correction, interleaving technique and check-sum information is applied, shall be divided into blocks, each of which corresponding to one information symbol in the applied test signal (see subclause 4.3.1). The total number of incorrect information symbols relative to the total number of information symbols shall be registered.

4.5 Impedance of test signal sources

4.5.1 Equipment ports

Equipment ports are classified as follows:

- RF port: an equipment terminal carrying RF signals, i.e. transmitter or receiver antenna terminal;
- analogue port: an equipment terminal carrying analogue signals (see subclause 3.1.2);
- digital port: an equipment terminal carrying digital signals (see subclause 3.1.3).

When a port is an output port, the test impedance shall mean the load impedance presented to the port by the external test equipment.

When a port is an input port, the test impedance shall mean the source impedance presented to the port by the external test equipment. Sources of test signals for application to the equipment input shall be connected through a network such that, irrespective of whether one or more test signals are applied to the equipment simultaneously, the impedance or circuit presented to the equipment input is equal to that specified in table 1.

4.5.2 Impedances

For the ports referred to in subclause 4.5.1 the following impedances shall be used:

Table 1

Port	Application	Impedance (note 1)
RF port below 1,6 MHz	Transmitter test load below 1,6 MHz	3 Ω non-reactive in series with 400 pF (note 2)
RF port between 1,6 and 4 MHz	Transmitter test load between 1,6 MHz and 4 MHz, optional receiver test impedance below 4 MHz	10 Ω non-reactive in series with 250 pF (note 2)
RF port above 4 MHz	Transmitter test load above 4 MHz, receiver test impedance	50 Ω non-reactive (note 3)
Analogue port	DSC analogue signals, load/source	600 Ω non-reactive (note 3)
Digital port	DSC digital signals, load/source	50 Ω non-reactive in series with 50 Ω non-reactive (note 3)
NOTE 1: This table shall in no way imply that the equipment shall only work with antennas having these characteristics.		
NOTE 2: Capacitance values in this network shall be substantially constant over the frequency range of measurement.		
NOTE 3: This impedance shall be substantially constant over the frequency range of measurement.		

The arrangement used shall be stated in the test report.

4.5.2.1 Non-integrated equipment

If the equipment is designed as an independent unit, the source impedance circuit for signals used for testing the decoder shall either be 600 Ω free of earth or shall comply with ITU-T Recommendation V.11 [12].

4.6 Connection of test signals

Sources of test signals for application to the equipment input shall be connected through a network such that, irrespective of whether one or more test signals are applied to the equipment simultaneously, the impedance or circuit presented to the equipment input is equal to that specified in table 1.

In the case of multiple test signals, steps shall be taken to prevent any undesirable effects due to interactions between signals in the generators or other sources.

The level of the analogue test signal shall be expressed by the electromotive force (emf) existing at the point where the signal is fed to the receiving or decoding part of the equipment.

4.7 Test power source

During conformance tests, the equipment shall be powered from a test power source capable of producing normal and extreme test voltages as specified in subclauses 4.9.2 and 4.10.3.

The internal impedance of the test power source shall be low enough for its effect on the test results to be negligible. For the purposes of tests, the voltage of the power supply shall be measured at the input terminals of the equipment.

If the equipment is provided with a permanently connected power cable, the test voltage shall be that measured at the point of connection of the power cable to the equipment.

The test power source voltages shall be maintained within a tolerance of $\pm 3\%$ relative to the voltage at the beginning of each test.

4.8 Internally generated signals

For conformance testing and maintenance purposes the equipment shall have facilities not accessible to the operator to generate a continuous B or Y signal and dot pattern.

For conformance testing the VHF equipment shall have facilities not accessible to the operator for generating an unmodulated carrier.

4.9 Normal test conditions

4.9.1 Normal temperature and humidity

The normal temperature and humidity conditions for tests shall be a combination of temperature and humidity within the following ranges:

- temperature: + 15° C to + 35° C;
- relative humidity: 20 % to 75 %.

4.9.2 Normal test power source

4.9.2.1 Mains voltage and mains frequency

The normal test voltage for equipment to be connected to the ac mains shall be the nominal mains voltage. For the purpose of this ETS the nominal voltage shall be the declared voltage or any of the declared voltages for which the equipment is indicated as having been designed.

The frequency of the test power supply corresponding to the ac mains shall be 50 Hz \pm 1 Hz.

4.9.2.2 Secondary battery power source

Where the equipment is designed to operate from a battery, the normal test voltage shall be the nominal voltage of the battery (e.g. 12 volts, 24 volts, etc.).

4.9.2.3 Other power sources

For operation from other power sources, the normal test voltage shall be that stated by the manufacturer.

4.10 Extreme test conditions

4.10.1 Temperatures when testing under extreme conditions

When testing under extreme conditions, the measurements shall be carried out at - 15°C (\pm 3°C) and + 55° (\pm 3°C) for below deck equipment, and - 25°C (\pm 3°C) and + 55°C (\pm 3°C) for above deck equipment, according to the procedure described in subclause 4.10.2.

4.10.2 Procedures of tests at extreme temperatures

Before making measurements, the equipment shall have reached thermal balance in the test chamber at the specified temperature (see subclause 4.10.1). The equipment shall be switched off during the temperature stabilising period, except as provided in subclause 3.12.3. After this period any climatic control devices provided in the equipment may be switched on. 30 minutes later the equipment shall be switched on and be subjected to the specified performance check. The sequence of measurements shall be chosen, and the humidity content in the test chamber shall be controlled so that excessive condensation does not occur.

At the end of the test, and with the equipment still in the chamber, the chamber shall be brought to room temperature in not less than 1 hour. The equipment shall then be exposed to normal room temperature and humidity for not less than 3 hours before the next test is carried out.

The maximum rate of raising or reducing the temperature of the chamber in which the equipment is being tested shall be 1° C/min.

4.10.3 Extreme values of test power source

4.10.3.1 Mains voltage and mains frequency

The extreme test voltages for equipment to be connected to a mains supply shall be the nominal mains voltage $\pm 10\%$.

The frequency of the test power supply corresponding to the mains shall be $50\text{ Hz} \pm 1\text{ Hz}$.

4.10.3.2 Secondary battery power sources

When the equipment is intended for operation from a secondary battery power supply, the extreme test voltages shall be 1.3 and 0.9 times the nominal voltage of the battery (e.g. 12 volts, 24 volts etc.).

4.10.3.3 Other power sources

For equipment using other power sources, the extreme test voltages shall be those stated by the manufacturer.

4.11 Environmental tests

4.11.1 Introduction

The equipment shall be capable of continuous operation under the conditions of various sea states, vibration, humidity and change of temperature likely to be experienced on a ship in which it is installed.

4.11.2 Procedure

Environmental tests shall be carried out before tests of the same equipment in respect to the other requirements of this ETS are performed.

Unless otherwise stated, the equipment shall be connected to an electrical power source only during the periods for which it is specified that electrical tests shall be carried out. These shall be done with normal test voltage.

4.11.3 Performance check

For the purpose of this ETS, the term performance check shall be taken to mean:

- a) for receiver with decoder, a check of the calling sensitivity:
 - 1) calling sensitivity:
 - i) for MF/HF equipment, the receiver input terminal shall be connected to the artificial antenna specified in subclause 4.5.2 and an RF signal at a nominal frequency of the receiver and modulated with standard test signal no. 1 containing DSC calls shall be applied. The level of the test signal shall be $6\text{ dB}\mu\text{V}$. The decoded symbol error rate shall be less than 10^{-2} ;
 - ii) for VHF equipment, the receiver input terminal shall be connected to the artificial antenna specified in subclause 4.5.2 and an RF signal at the nominal frequency of channel 70 modulated with standard test signal no. 4 containing DSC calls shall be applied. The level of the test signal shall be $6\text{ dB}\mu\text{V}$. The decoded symbol error rate shall be less than 10^{-2} ;
- b) for separate decoder, a check of the correct decoding of DSC signals:
 - 1) decoding of DSC signals:
 - i) for both MF/HF and VHF decoders, the input terminals shall be connected to a calibrated apparatus for generation of DSC signals. The level of the signals shall be within $+7\text{ V}$ and -7 V with a differential voltage of $\geq 2,0\text{ V}$ for binary voltage and

between ± 10 dB relative to 0,775 V rms for analogue signals. The decoded call sequences at the output of the decoders shall have correct technical format, including error-check character;

- c) for transmitter with encoder, a check of output power, frequency error and undesignated distress call:
- 1) output power:
 - i) for MF/HF equipment, the method of measurement in subclause 5.5.2 and the limits in subclause 5.2.3 apply;
 - ii) for VHF equipment, the method of measurement in subclause 6.3.2 apply. With the power switch set at maximum, the output power shall be between 6 W and 25 W;
 - 2) frequency error:
 - i) for MF/HF equipment, the method of measurement in subclause 5.1.2 shall apply, with the measurement performed only for a continuous B or Y state. The relevant limit in subclause 5.1.3 shall apply;
 - ii) for VHF equipment, the method of measurement and the limit in subclause 6.1 shall apply;
 - 3) undesignated distress call:
 - i) both MF/HF and VHF equipment, standard test signal no. 1 modulated with an undesignated distress call. The signal shall be decoded without character errors;
- d) for separate encoder, a check of the output voltage, frequency error and undesignated distress call:
- 1) output voltage:
 - i) for both MF/HF and VHF encoders, the method of measurement and relevant limit in subclause 7.2 shall apply;
 - 2) frequency error:
 - i) for MF/HF encoder, the method of measurement in subclause 7.1.2 shall apply, with the measurement performed only for continuous B or Y state. The relevant limit in subclause 7.1.3 shall apply;
 - ii) for VHF encoder, the method of measurement in subclause 8.1.2 shall apply, with the measurement performed only for a continuous B or Y state. The relevant limit in subclause 7.1.3 shall apply;
 - 3) undesignated distress call:
 - i) for both MF/HF and VHF encoders, standard test signal no. 1 modulated with an undesignated distress call shall be applied. The signal shall be decoded without character errors.

4.11.4 Vibration test

4.11.4.1 Method of measurement

The equipment, complete with any shock absorbers which are part of it, shall be clamped to the vibration table by its normal means of support and in its normal attitude.

The equipment may be suspended to compensate for weight not capable of being withstood by the vibration table.

Provisions may be made to reduce or nullify any adverse effect on the equipment performance which could be caused by the presence of any electro-magnetic field due to the vibration unit.

Taking at least 15 minutes to cover each octave of frequency, the equipment shall be subjected to sinusoidal vertical vibration at all frequencies between:

- 5 Hz and 12,5 Hz with an excursion of $\pm 1,6 \text{ mm} \pm 10 \%$;
- 12,5 Hz and 25 Hz with an excursion of $\pm 0,38 \text{ mm} \pm 10 \%$;
- 25 Hz and 50 Hz with an excursion of $\pm 0,10 \text{ mm} \pm 10 \%$.

A resonance search shall be carried out during the vibration test. If resonance of any part of any component is observed, the equipment shall be subjected to a vibration endurance test at each resonance frequency with the duration of not less than 2 hours at the vibration level specified above.

The test shall be repeated with vibration in each of the mutual perpendicular direction in the horizontal plane.

A performance check shall be carried out during the test.

After conducting the vibration tests, the equipment shall be inspected for any mechanical deterioration.

4.11.4.2 Requirement

The requirement for the performance check shall be met.

There shall be no harmful deterioration of the equipment visible to the naked eye.

4.11.5 Temperature tests

4.11.5.1 Dry heat for externally mounted equipment

4.11.5.1.1 Method of measurement

The equipment shall be placed in a chamber of normal room temperature. The temperature shall be raised to and maintained at $+ 70^{\circ}\text{C} (\pm 3^{\circ}\text{C})$ for a period of at least 10 hours.

After this period any climatic control device provided in the equipment may be switched on and the chamber cooled to $+ 55^{\circ}\text{C} (\pm 3^{\circ}\text{C})$. The cooling of the chamber shall be completed within 30 minutes.

The equipment shall then be switched on and be subjected to a performance check.

The temperature of the chamber shall be maintained at $+ 55^{\circ}\text{C} (\pm 3^{\circ}\text{C})$ during the performance check.

At the end of the test, and with the equipment still in the chamber, the chamber shall be brought to room temperature in not less than 1 hour. The equipment shall then be exposed to normal room temperature and humidity for not less than 3 hours before the next test is carried out.

4.11.5.1.2 Requirement

The requirement for the performance check shall be met.

4.11.5.2 Damp heat cycle

4.11.5.2.1 Method of measurement

The equipment shall be placed in a chamber at normal room temperature and humidity which, steadily, over a period of 3 hours ($\pm 0,5$ hour), shall be heated from room temperature to $+ 40^{\circ}\text{C} (\pm 3^{\circ}\text{C})$ and shall during this period be brought to a relative humidity of 93 % ($\pm 2 \%$) so that excessive condensation is avoided.

These conditions shall be maintained for a period of at least 10 hours.

After this period, any climatic control devices provided within the equipment may be switched on.

30 minutes later the equipment shall be switched on, and shall then be kept working continuously for a period of 2 hours.

If the equipment being tested is, or includes, a transmitter, the transmitter shall be operated at the maximum power level and transmitting a distress signal in accordance with the procedures specified in ITU-R Recommendation M.541-5 [5].

The equipment shall be subjected to a performance check during the 2 hour period. The temperature and the relative humidity of the chamber shall be maintained at + 40°C ($\pm 3^\circ\text{C}$) and 93 % ($\pm 2\%$) during the 2 hour 30 minute period.

At the end of the test, and with the equipment still in the chamber, the chamber shall be brought to room temperature in not less than 1 hour. The equipment shall then be exposed to normal room temperature and humidity for not less than 3 hours, or until moisture has dispersed, which ever is longer, before the next test is carried out.

4.11.5.2.2 Requirement

The requirement for the performance check shall be met.

4.11.5.3 Low temperature cycle for externally mounted equipment

4.11.5.3.1 Method of measurement

The equipment shall be placed in a chamber at normal room temperature. Then the temperature shall be reduced to, and maintained at, - 30°C ($\pm 3^\circ\text{C}$) for a period of at least 10 hours.

Any climatic control devices provided in the equipment may then be switched on and the chamber warmed to - 20°C ($\pm 3^\circ\text{C}$). The warming of the chamber shall be completed within 30 minutes (± 5 minutes).

The temperature of the chamber shall then be maintained at - 20°C ($\pm 3^\circ\text{C}$) during a period of 1 hour 30 minutes.

The equipment shall be switched on and then subjected to a performance check during the last 30 minutes of the test. Any heat sources for the equipment may be switched on during the performance check.

At the end of the test, and with the equipment still in the chamber, the chamber shall be brought to room temperature in not less than 1 hour. The temperature shall then be exposed to normal room temperature for not less than 3 hours, or until moisture has dispersed, which ever is longer, before the next test is carried out.

4.11.5.3.2 Requirement

The requirement for the performance check shall be met.

4.11.6 Corrosion test

4.11.6.1 General

If sufficient evidence is provided by the applicant that the requirements of this subclause are met then this test may be omitted.

4.11.6.2 Method of measurement

The equipment shall be placed in a chamber fitted with apparatus capable of spraying in the form of fine mist, such as would be produced by a spray gun, a salt solution to the following formula:

- sodium chloride 26,50 g $\pm 10\%$;
- magnesium chloride 2,50 g $\pm 10\%$;

- magnesium sulphate 3,30 g \pm 10 %;
- calcium chloride 1,10 g \pm 10 %;
- potassium chloride 0,73 g \pm 10 %;
- sodium bicarbonate 0,20 g \pm 10 %;
- sodium bromide 0,28 g \pm 10 %;
- distilled water to make the solution up to 1 litre.

Alternatively a 5 % sodium chloride (NaCl) solution may be used.

The salt used for the test shall be high quality sodium chloride (NaCl) containing, when dry, not more than 0,1 % sodium iodide and not more than 0,3 % of total impurities.

Salt solution concentration shall be 5 % (\pm 1 %) by weight.

The solution shall be prepared by dissolving 5 parts \pm 1 by weight of salt in 95 parts by weight of distilled or demineralized water.

The pH value of the solution shall be between 6,5 and 7,2 at temperature of 20°C (\pm 2°C). The pH value shall be maintained within this range during conditioning; for this purpose, diluted hydrochloric acid or sodium hydroxide may be used to adjust the pH value, provided that the concentration of NaCl remains within the prescribed limits. The pH value shall be measured when preparing each new batch of solution.

The spraying apparatus shall be such that the products of corrosion cannot mix with the salt solution contained within the spray reservoir.

The equipment shall be sprayed simultaneously on all its external surfaces with the salt solution for a period of 1 hour.

This spraying shall be carried out 4 times with a storage period of 7 days at 40 °C (\pm 2 °C) after each spraying. The relative humidity during storage shall be maintained between 90 % and 95 %.

At the end of the total period the equipment shall be examined visually.

The equipment shall then be subjected to a performance check.

4.11.6.3 Requirements

There shall be no undue deterioration or corrosion of the metal parts, finishes, material or component parts visible to the naked eye.

In the case of hermetically sealed equipment there shall be no evidence of moisture penetration.

The requirement for the performance check shall be met.

4.11.7 Rain test

4.11.7.1 General

This test corresponds to IEC 529, [10] table II, first column, numeral 6: "Equipment protected against heavy seas".

The test shall only be performed for equipment to be externally mounted.

4.11.7.2 Method of measurement

The equipment shall be placed in an appropriate measurement chamber.

Throughout the test the equipment shall be working normally.

The test shall be carried out by spraying the equipment from all practicable directions with a stream of water from a hose.

The conditions to be observed are as follows:

- internal diameter of the nozzle: 12,5 mm;
- delivery rate: 100 l/min ($\pm 5\%$);
- water pressure at the nozzle: approx. 100 kPa (1 bar);
- test duration: 30 minutes;
- distance from the nozzle to the equipment surface: approximately 3 m.

The pressure shall be adjusted to achieve the specified delivery rate. At 100 kPa the water shall rise freely for a vertical distance of approximately 8 metres above the nozzle.

At the end of the test the equipment shall be subjected to a performance check and inspected.

Following inspection, the equipment shall be resealed in accordance with the manufacturer's instructions.

4.11.7.3 Requirements

The requirements for the performance check shall be met.

There shall be no evidence of ingress of water visible to the naked eye.

4.12 Measurement uncertainty and interpretation of the measuring results

4.12.1 Measurement uncertainty

Table 2: Maximum values of measurement uncertainty

Absolute measurement uncertainty	Maximum values
RF frequency:	$\pm 1 \times 10^{-7}$
RF power:	$\pm 0,75$ dB
Maximum frequency deviation:	
- within 300 Hz to 6 kHz of audio frequency	$\pm 5\%$
- within 6 kHz to 25 kHz of audio frequency	± 3 dB
Deviation limitation:	$\pm 5\%$
Adjacent channel power	± 5 dB
Conducted spurious emission of transmitter	± 4 dB
Audio output power	$\pm 0,5$ dB
Amplitude characteristics of receiver limiter	$\pm 1,5$ dB
Sensitivity	± 3 dB
Conducted spurious emission of receiver	± 3 dB
Two-signal measurement	± 4 dB
Three signal measurement	± 3 dB
Radiated emission of transmitter	± 6 dB
Radiated emission of receiver	± 6 dB
Transmitter transient time	$\pm 20\%$
Transmitter transient frequency	± 250 Hz
Receiver desensitisation (duplex operation)	$\pm 0,5$ dB

For the test methods according to this ETS the uncertainty figures are valid to a confidence level of 95 % calculated according to the methods described in ETR 028 [11].

4.12.2 Interpretation of measurement results

The interpretation of the results recorded in a test report for the measurements described in this ETS shall be as follows:

- the measured value related to the corresponding limit shall be used to decide whether an equipment meets the requirements of the ETS;
- the measurement uncertainty value for the measurement of each parameter shall be included in the test report;
- the recorded value of the measurement uncertainty shall be for each measurement equal to or lower than the figures in table 2.

5 MF/HF transmitter with integrated DSC encoder

5.1 Frequency error

5.1.1 Definition

The frequency error is the difference between the measured frequency and its nominal value.

5.1.2 Method of measurement

The transmitter shall be connected to the artificial antenna as specified in subclause 4.5. The transmitter shall be set to a radio frequency assigned for DSC operation in at least the highest frequency band for which the equipment has been designed.

The output power may be reduced but shall not be less than 60 W. The measurement shall be performed for both continuous B - and Y - state.

The measurements shall be carried out under normal (subclause 4.9) and extreme test conditions (subclauses 4.10.1 and 4.10.3 applied simultaneously) following the warming up period (see subclause 3.12).

5.1.3 Limits

The measured frequency shall at any time for the B - state be within ± 10 Hz relative to the assigned frequency + 85 Hz and for the Y - state within ± 10 Hz relative to the assigned frequency - 85 Hz.

The frequency difference between the B - state and the Y - state shall be $170 \text{ Hz} \pm 2 \text{ Hz}$.

5.2 RF output power

5.2.1 Definition

The radio frequency output power is defined as the mean power delivered to the artificial antenna.

5.2.2 Method of measurement

The transmitter output shall be connected to an artificial antenna as indicated under subclause 4.5.

The equipment shall be set to transmit a continuous dot pattern, and the delivered mean output power shall be measured.

The measurement shall be carried out under normal test conditions (subclause 4.9) and under extreme test conditions (subclauses 4.10.1 and 4.10.3 applied simultaneously).

5.2.3 Limits

For transmitters designed for frequencies within the band 415 kHz - 526,5 kHz, the mean power shall be at least 60 W.

For transmitters designed for maritime frequencies within the frequency range 1,6 MHz - 4 MHz, the mean power shall be at least 60 W and shall not exceed 400 W.

For transmitters designed for maritime frequencies within the frequency range 4 MHz - 27,5 MHz, the mean power shall be at least 60 W and shall not exceed 1 500 W.

5.3 Modulation rate

5.3.1 Definition

The modulation rate is the bit stream speed measured in bits per second.

5.3.2 Method of measurement

The equipment shall be set to transmit continuous dot pattern.

The RF output terminal of the equipment shall be connected to a linear FM demodulator. The output of the demodulator shall be limited in bandwidth by a low pass filter with a cut-off frequency of 1 kHz and a slope of 12 dB/octave.

The frequency of the output shall be measured.

5.3.3 Limits

The frequency shall be $50 \text{ Hz} \pm 30 \text{ ppm}$ corresponding to a modulation rate of 100 bit/s.

5.4 Residual modulation of the transmitter

5.4.1 Definition

The residual modulation of the transmitter is defined as the ratio in dB of the demodulated B or Y signal relative to the demodulated dot pattern.

5.4.2 Method of measurement

The RF output terminal of the equipment shall be connected to a linear FM demodulator. The output of the demodulator shall be limited in bandwidth by a low-pass filter with a cut-off frequency of 1 kHz and a slope of 12 dB/octave.

The rms output level shall be measured during transmission of the B or Y signal and during the transmission of a continuous dot pattern.

The ratio of the two rms output levels from the demodulator shall be determined. DC voltages shall be suppressed by an AC coupling device so that they do not influence the results of the measurements.

5.4.3 Limits

The residual modulation shall not be greater than - 26 dB.

5.5 Unwanted emission

5.5.1 Definition

Unwanted emissions consist of spurious emissions and out-of-band emissions.

Spurious emissions are emissions on a frequency or frequencies which are outside the necessary bandwidth and the level of which may be reduced without affecting the corresponding transmission of information. Spurious emissions include harmonic emissions, parasitic emissions, intermodulation products and frequency conversion products, but exclude out-of-band emissions.

Out-of-band emissions are emissions on a frequency or frequencies immediately outside the necessary bandwidth which results from the modulation process, but excluding spurious emissions.

5.5.2 Method of measurement

The equipment shall be set to transmit continuous dot pattern.

The measurement shall be carried out with a frequency selective measuring instrument, capable of indicating the individual emission components within the frequency range 9 kHz - 2 GHz.

The bandwidth of the selective analyser shall be:

- 200 Hz in the frequency range from 9 kHz to 150 kHz;
- 9 to 10 kHz in the frequency band from 150 kHz to 30 MHz;
- 100 to 120 kHz in the frequency band 30 MHz to 1 GHz;
- 1 MHz above 1 GHz.

The detector shall be a peak detector.

5.5.3 Limits

The unwanted emissions shall fulfil the requirement shown in figure 1, 0 dB refers to the registered mean power output level.

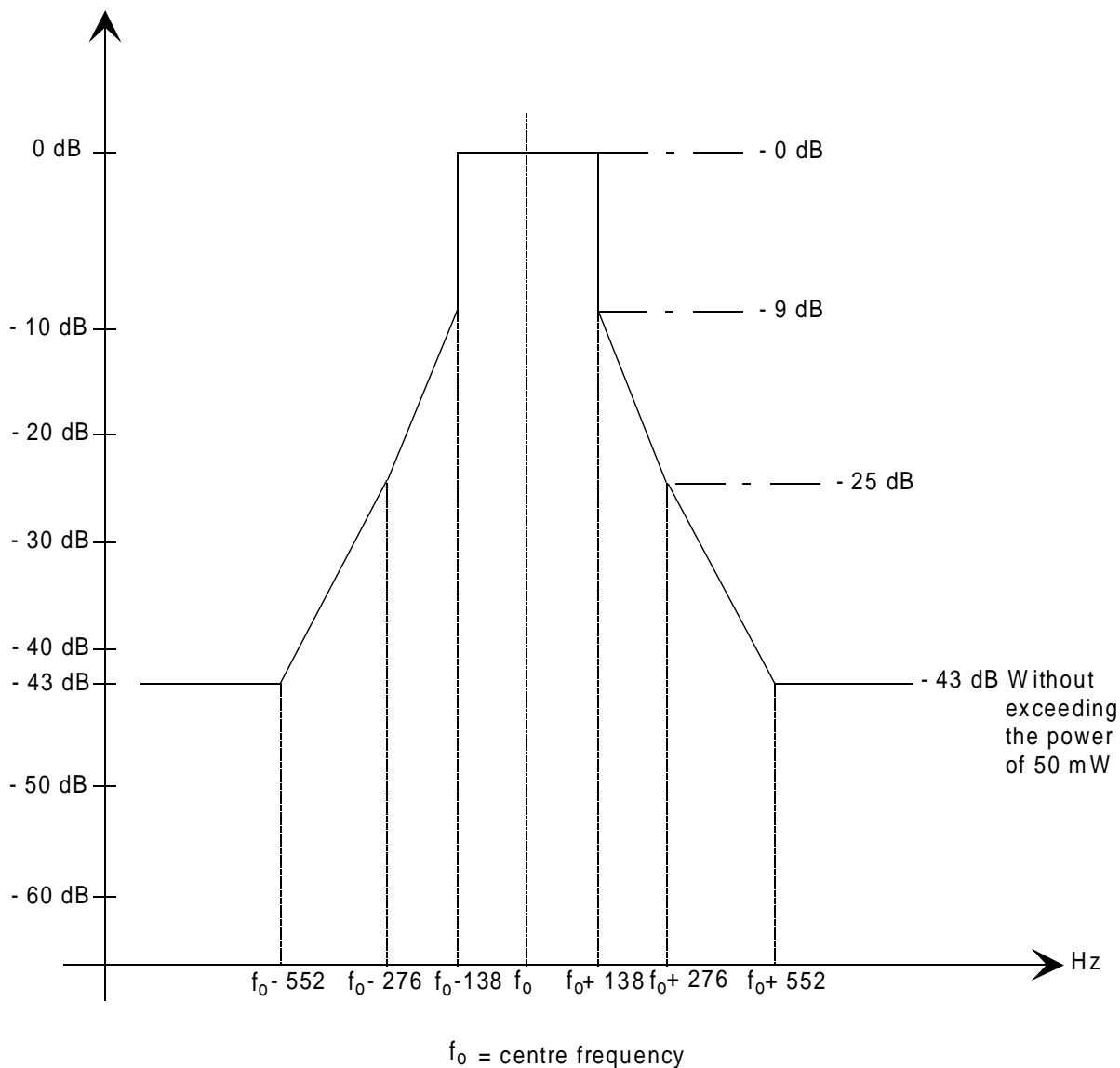

Figure 1: Unwanted spectral components (MF/HF transmitter with DSC encoder)

5.6 Testing of generated call sequences

The output of the equipment shall be connected to apparatus calibrated for decoding and printing out the information content of the call sequences generated by the equipment.

The equipment shall be set to transmit DSC calls as specified in annex A in order to verify that the requirements of ITU-R Recommendation M.493-6 [4] regarding message composition and content are met.

The generated calls shall be analysed with the calibrated apparatus for correct configuration of the signal format, including time diversity.

The telecommands used shall be stated in the test report.

5.7 Tuning time

Transmitters for digital selective calling on MF and/or HF frequencies shall be able to be changed from operation at any frequency to operation on any other frequency as quickly as possible, but in any event within a period not exceeding 15 seconds. The transmission of a call shall not commence until the tuning operation has been completed.

Transmission shall be inhibited until the frequency has stabilised within the required limits.

5.8 Protection of transmitter

5.8.1 Definition

This represents the protection afforded to the transmitter against damage which may be caused by faults occurring in the ship's transmitting antenna.

5.8.2 Method of measurement

Whilst the transmitter is being driven to the rated output power by sending dot pattern, the antenna terminals shall first be short-circuited and then open-circuited, in each case for a period of 5 minutes.

5.8.3 Limits

During the test the transmitter shall not be damaged. After removal of the short-circuit or open-circuit conditions, the transmitter shall be able to operate normally.

6 VHF transmitter with integrated DSC encoder

6.1 Frequency error (carrier)

6.1.1 Definition

The frequency error is the difference between the measured carrier frequency and its nominal value.

6.1.2 Method of measurement

The transmitter shall be connected to the artificial antenna as specified in subclause 4.5. The transmitter shall be set to channel 70.

The measurement shall be performed without modulation.

The measurements shall be carried out under normal (subclause 4.9) and extreme test conditions (subclauses 4.10.1 and 4.10.3 applied simultaneously).

6.1.3 Limits

The frequency error shall be within $\pm 1,5$ kHz.

6.2 Frequency error (demodulated signal)

6.2.1 Definition

The frequency error for the B and the Y state is the difference between the measured frequency from the demodulator and the nominal values.

6.2.2 Method of measurement

The transmitter shall be connected to the artificial antenna as specified in subclause 4.5 and suitable FM demodulator. The transmitter shall be set to channel 70.

The equipment shall be set to transmit a continuous B or Y state.

The measurement shall be performed by measuring the demodulated output, for both the continuous B and Y state.

The measurements shall be carried out under normal (subclause 4.9) and extreme test conditions (subclauses 4.10.1 and 4.10.3 applied simultaneously).

6.2.3 Limits

The measured frequency from the demodulator at any time for the B state shall be within 1 300 Hz \pm 10 Hz and for the Y state within 2 100 Hz \pm 10 Hz.

6.3 Carrier power

6.3.1 Definition

For the purpose of this ETS the carrier power is the mean power delivered to the artificial antenna during one radio-frequency cycle.

The rated output power is the carrier power declared by the manufacturer.

6.3.2 Method of measurement

The transmitter shall be tuned to channel 70 and connected to an artificial antenna (subclause 4.5). The power delivered to this artificial antenna shall be measured. The measurements shall be made under normal test conditions (subclause 4.9), and under extreme test conditions (subclauses 4.10.1 and 4.10.3 applied simultaneously).

6.3.3 Limits

6.3.3.1 Normal test conditions

With the output power switch set at maximum, the carrier power shall remain between 6 W and 25 W and not differ by more than 1,5 dB from the rated output power.

With the output power switch set at minimum or during automatic power reduction (see subclause 3.1.8), the carrier power shall remain between 0,1 W and 1,0 W.

6.3.3.2 Extreme test conditions

With the output power switch set at maximum, the carrier power shall remain between 6 W and 25 W and be within + 2 dB, - 3 dB of the rated output power.

With the output power switch set at minimum or during automatic power reduction (see subclause 3.1.8), the carrier power shall remain between 0,1 and 1,0 W.

6.4 Modulation index

6.4.1 Definition

For the purpose of this ETS, the modulation index is the ratio between the frequency deviation and the frequency of the modulation signal.

The frequency deviation is the difference between the instantaneous frequency of the modulated RF signal and the carrier frequency.

6.4.2 Method of measurement

The equipment shall be set to transmit continuous B and then Y signals. The frequency deviations shall be measured.

6.4.3 Limits

The modulation index shall be 2,0 \pm 10 %.

6.5 Modulation rate

6.5.1 Definition

The modulation rate is the bit stream speed measured in bits per second.

6.5.2 Method of measurement

The equipment shall be set to transmit continuous dot pattern.

The RF output terminal of the equipment shall be connected to a linear FM demodulator. The output of the demodulator shall be limited in bandwidth by a low pass filter with a cut-off frequency of 1 kHz and a slope of 12 dB/octave.

The frequency of the output shall be measured.

6.5.3 Limits

The frequency shall be 600 Hz \pm 30 ppm corresponding to a modulation rate of 1 200 bit/s.

6.6 Residual modulation of the transmitter

6.6.1 Definition

The residual modulation of the transmitter is defined as the ratio in dB of the demodulated B or Y signal relative to the demodulated dot pattern.

6.6.2 Method of measurement

The RF output terminal of the equipment shall be fed via a linear demodulator with a de-emphasis network of 6 dB/octave to another linear FM demodulator. The output of the second demodulator shall be limited in bandwidth by a low-pass filter with a cut-off frequency of 3 kHz and a slope of 12 dB/octave.

The rms output level shall be measured during the transmission of continuous dot pattern and during the transmission of continuous B or Y signals.

The ratio of the two rms output levels from the second demodulator shall be determined.

DC voltages shall be suppressed by an ac coupling device so that they do not influence the results of the measurements.

6.6.3 Limits

The residual modulation shall not be greater than - 26 dB.

6.7 Adjacent channel power

6.7.1 Definition

The adjacent channel power is that part of the total power output of a transmitter when modulated with continuous dot pattern which falls within a specified passband centred on the nominal frequency of either of the adjacent channels. This power is the sum of the mean power produced by the modulation, hum and noise of the transmitter.

6.7.2 Measurement

6.7.2.1 Method of measurement

The adjacent channel power shall be measured with a power measuring receiver which conforms to annex B (referred to as the "receiver").

The measurements shall be carried out as follows:

- a) the transmitter shall be operated at the carrier power determined in subclause 6.3 under normal test conditions. The output of the transmitter shall be linked to the input of the "receiver" by a connecting device such that the impedance presented to the transmitter is 50 Ω and the level at the "receiver" input is appropriate;
- b) with the transmitter unmodulated, the tuning of the "receiver" shall be adjusted so that a maximum response is obtained. This is the 0 dB response point. The receiver attenuator setting and the reading of the meter shall be recorded;
- c) the tuning of the "receiver" shall be adjusted away from the carrier so that the receiver - 6 dB response nearest to the transmitter carrier frequency is located at a displacement from the nominal carrier frequency of 17 kHz;
- d) the transmitter shall be modulated with continuous dot pattern;
- e) the "receiver" variable attenuator shall be adjusted to obtain the same meter reading as in step b) or a known relation to it;
- f) the ratio of adjacent channel power to carrier power is the difference between the attenuator settings in steps b) and e), corrected for any differences in the reading of the meter;
- g) the measurement shall be repeated with the "receiver" tuned to the other side of the carrier.

6.7.3 Limits

The adjacent channel power shall not exceed a value of 70 dB below the carrier power of the transmitter without any need to be below 0,2 μ W.

6.8 Conducted spurious emissions conveyed to the antenna

6.8.1 Definition

Conducted spurious emissions are emissions on a frequency or frequencies which are outside the necessary bandwidth and the level of which may be reduced without affecting the corresponding transmission of information. Spurious emissions include harmonic emissions, parasitic emissions, intermodulation products and frequency conversion products, but exclude out of band emissions.

6.8.2 Method of measurement

Conducted spurious emissions shall be measured with the transmitter connected to the artificial antenna (see subclause 4.5). The equipment shall be set to transmit continuous dot pattern.

The measurements shall be made over a range from 9 kHz to 2 GHz, excluding the channel on which the transmitter is operating and its adjacent channels.

The bandwidth of the selective analyser shall be:

- 200 Hz in the frequency range from 9 kHz to 150 kHz;
- 9 to 10 kHz in the frequency band from 150 kHz to 30 Mhz;
- 100 to 120 kHz in the frequency band 30 MHz to 1 GHz;
- 1 MHz above 1 GHz.

The detector shall be a peak detector.

6.8.3 Limit

The power of any conducted spurious emission on any discrete frequency shall not exceed 0,25 μ W.

6.9 Testing of generated call sequences

The output of the equipment shall be connected to calibrated apparatus for decoding and printing out the information content of the call sequences generated by the equipment.

The equipment shall be set to transmit DSC calls as specified in annex A in order to verify that the requirements of ITU-R Recommendation M.493-6 [4] regarding message composition and content are met.

The generated calls shall be analysed with the calibrated apparatus for correct configuration of the signal format, including time diversity.

The telecommands used shall be stated in the test report.

6.10 Transient frequency behaviour of the transmitter

6.10.1 Definitions

The transient frequency behaviour of the transmitter is the variation in time of the transmitter frequency difference from the nominal frequency of the transmitter when the RF output power is switched on and off.

t_{on} : according to the method of measurement described in subclause 6.10.2 the switch-on instant t_{on} of a transmitter is defined by the condition when the output power measured at the antenna terminal exceeds 0,1 % of the nominal power;

t_1 : period of time starting at t_{on} and finishing according to table 3;

t_2 : period of time starting at the end of t_1 and finishing according to table 3;

t_{off} : switch-off instant defined by the condition when the nominal power falls below 0,1 % of the nominal power;

t_3 : period of time that finishing at t_{off} and starting according to table 3.

Table 3: Time periods

Time period	Value (ms)
t_1	5,0
t_2	20,0
t_3	5,0
NOTE:	During the periods t_1 and t_3 the frequency difference shall not exceed the value of 1 channel separation. During the period t_2 the frequency difference shall not exceed the value of half a channel separation.

6.10.2 Method of measurement

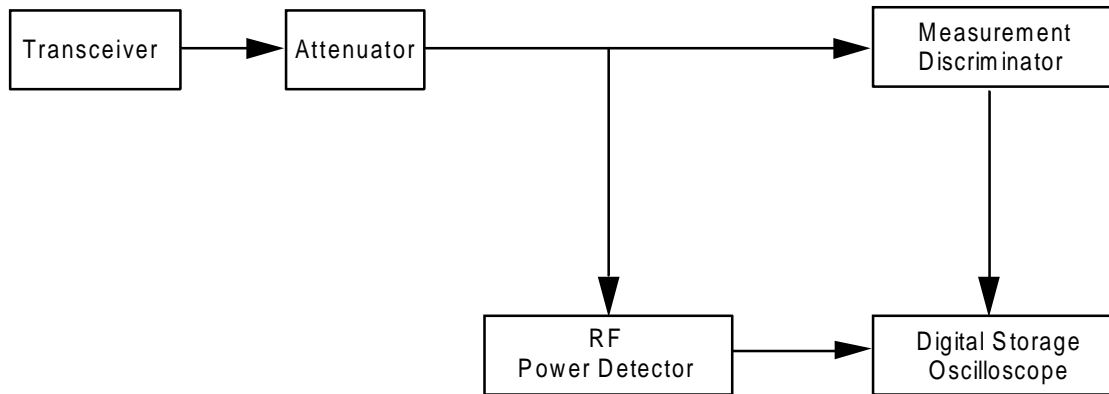

Figure 2: Measurement arrangement

Two signals shall be connected to the test discriminator via a combining network (see subclause 4.6).

The transmitter shall be connected to a 50 Ω power attenuator.

The output of the power attenuator shall be connected to the test discriminator via one input of the combining network.

A test signal generator shall be connected to the second input of the combining network.

The test signal shall be adjusted to the nominal frequency of the transmitter.

The test signal shall be modulated by a frequency of 1 kHz with a deviation of ± 25 kHz.

The test signal level shall be adjusted to correspond to 0,1 % of the power of the transmitter under test measured at the input of the test discriminator. This level shall be maintained throughout the measurement.

The amplitude difference (a_d) and the frequency difference (f_d) output of the test discriminator shall be connected to a storage oscilloscope.

The storage oscilloscope shall be set to display the channel corresponding to the (f_d) input up to ± 1 channel frequency difference, corresponding to the relevant channel separation, from the nominal frequency.

The storage oscilloscope shall be set to a sweep rate of 10 ms/div and set so that the triggering occurs at 1 div from the left edge of the display.

The display will show the 1 kHz test signal continuously.

The storage oscilloscope shall then be set to trigger on the channel corresponding to the amplitude difference (a_d) input at a low input level, rising.

The transmitter shall then be switched on, without modulation, to produce the trigger pulse and a picture on the display.

The result of the change in the ratio of power between the test signal and the transmitter output will, due to the capture ratio of the test discriminator, produce two separate sides on the picture, one showing the 1 kHz test signal, the other the frequency difference of the transmitter versus time.

The moment when the 1 kHz test signal is completely suppressed is considered to provide t_{on} .

The periods of time t_1 and t_2 as defined in the table shall be used to define the appropriate template.

During the period of time t_1 and t_2 the frequency difference shall not exceed the values given in the note in table 3, subclause 6.10.1.

The frequency difference after the end of t_2 shall be within the limit of the frequency error, subclause 6.1 ($\pm 1,5$ kHz).

The result shall be recorded as frequency difference versus time.

The transmitter shall remain switched on.

The storage oscilloscope shall be set to trigger on the channel corresponding to the amplitude difference (a_d) input at a high input level, decaying and set so that the triggering occurs at 1 div. from the right edge of the display.

The transmitter shall then be switched off.

The moment when the 1 kHz test signal starts to rise is considered to provide t_{off} .

The period of time t_3 as defined in the table shall be used to define the appropriate template.

During the period of time t_3 the frequency difference shall not exceed the values given in the note in table 3, subclause 6.10.1.

Before the start of t_3 the frequency difference shall be within the limit of the frequency error, subclause 6.1 ($\pm 1,5$ kHz).

The result shall be recorded as frequency difference versus time.

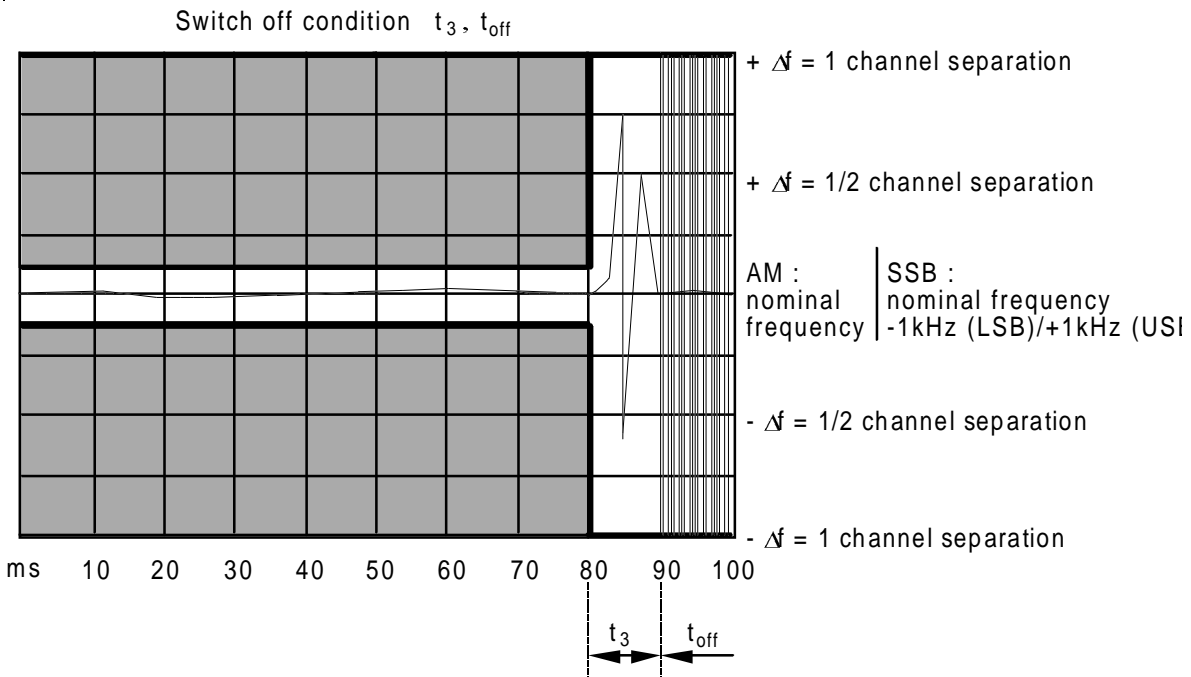
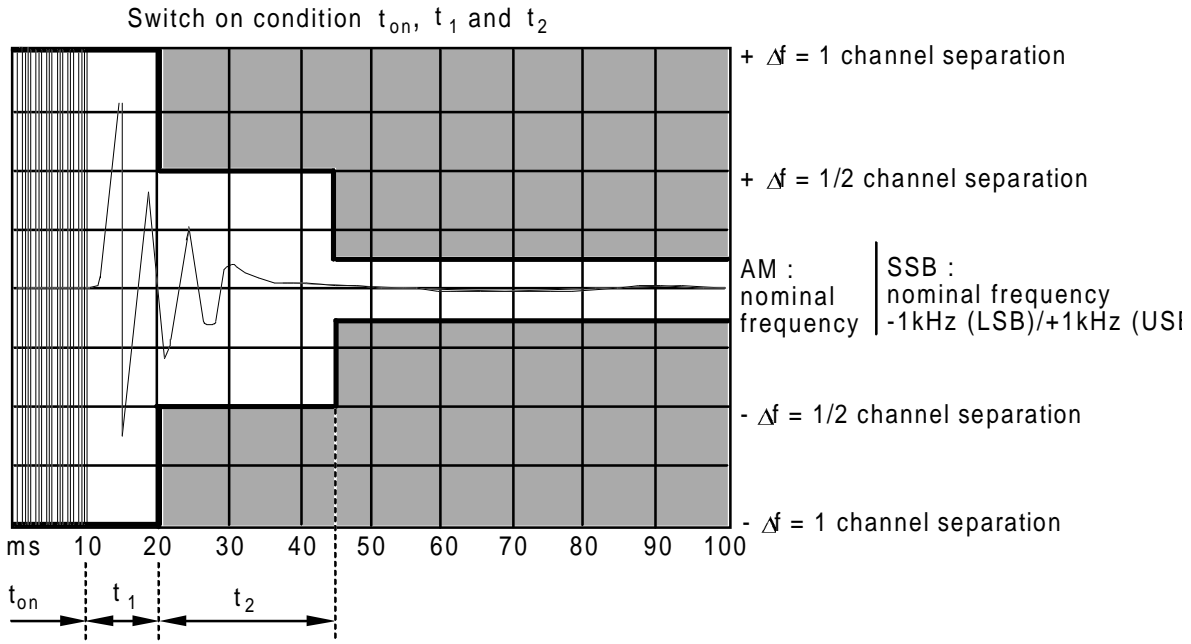

Figure 3: Storage oscilloscope view t_1 , t_2 and t_3

7 MF/HF DSC encoder

7.1 Frequency error

7.1.1 Definition

The frequency error is the difference between the measured frequency and its nominal value.

7.1.2 Method of measurement

The measurement shall be carried out under normal test conditions (subclause 4.9) and under extreme test conditions (subclauses 4.10.1 and 4.10.3 applied simultaneously).

A non-reactive load of 600 Ω shall be connected to the output terminal of the equipment. The frequencies corresponding to the B state and the Y state (ITU-R Recommendation M.493-6 [4], Annex 1, subclause 1.4) shall be measured on the output terminal. The encoder shall be set to generate continuous B or Y signal.

7.1.3 Limits

The measured frequency following after the warming up period (subclause 3.12) shall at any time for the B state be within ± 1 Hz relative to 1 700 Hz + 85 Hz and for the Y state be within ± 1 Hz relative to 1 700 Hz - 85 Hz.

7.2 Output voltage

7.2.1 Definition

The output voltage is the audio voltage measured across a non-reactive load of 600 Ω . For binary output, this voltage is the level of the "1" and the "0".

7.2.2 Method of measurement

An appropriate load of 600 Ω as specified in subclause 4.5.3 shall be connected to the output terminal of the equipment.

The equipment shall be set to transmit continuous dot pattern and the rms output voltage during the dot pattern shall be measured.

7.2.3 Limits

7.2.3.1 Analogue voltage

The output voltage shall be adjustable by at least ± 10 dB from 0,775 V (rms).

The output level of the two tones shall not vary by more than 0,5 dB during the transmission of an information block or control signal and each tone shall be within 0,5 dB relative to the other.

7.2.3.2 Binary voltage

The levels of the output voltage shall conform with ITU-T Recommendation V.11 [12].

7.3 Bit stream speed

7.3.1 Definition

The bit stream speed is the number of bits per second.

7.3.2 Method of measurement

The equipment shall be set to transmit a continuous dot pattern.

The output terminal of the equipment shall be connected to a linear FM demodulator. The output of the demodulator shall be limited in bandwidth by a low pass filter with a cut-off frequency of 1 kHz and a slope of 12 dB/octave.

The frequency of the dot pattern shall be measured.

7.3.3 Limits

The frequency shall be 50 Hz \pm 30 ppm corresponding to a bit stream speed of 100 bit/s.

7.4 Unwanted spectral components of the output signal

7.4.1 Definition

Unwanted spectral components are emissions on a frequency or frequencies which are outside the necessary bandwidth and the level of which may be reduced without affecting the corresponding transmission of information. Unwanted spectral components include harmonic spectral components and intermodulation products.

7.4.2 Method of measurement

The output terminals of the equipment shall be connected to a non-reactive load of 600 Ω .

The equipment shall be set to transmit continuous dot pattern. The unwanted spectral components in the output signal shall be determined.

7.4.3 Limits

The unwanted spectral components shall fulfil the requirement in figure 4, 0 dB refers to the registered mean power output level.

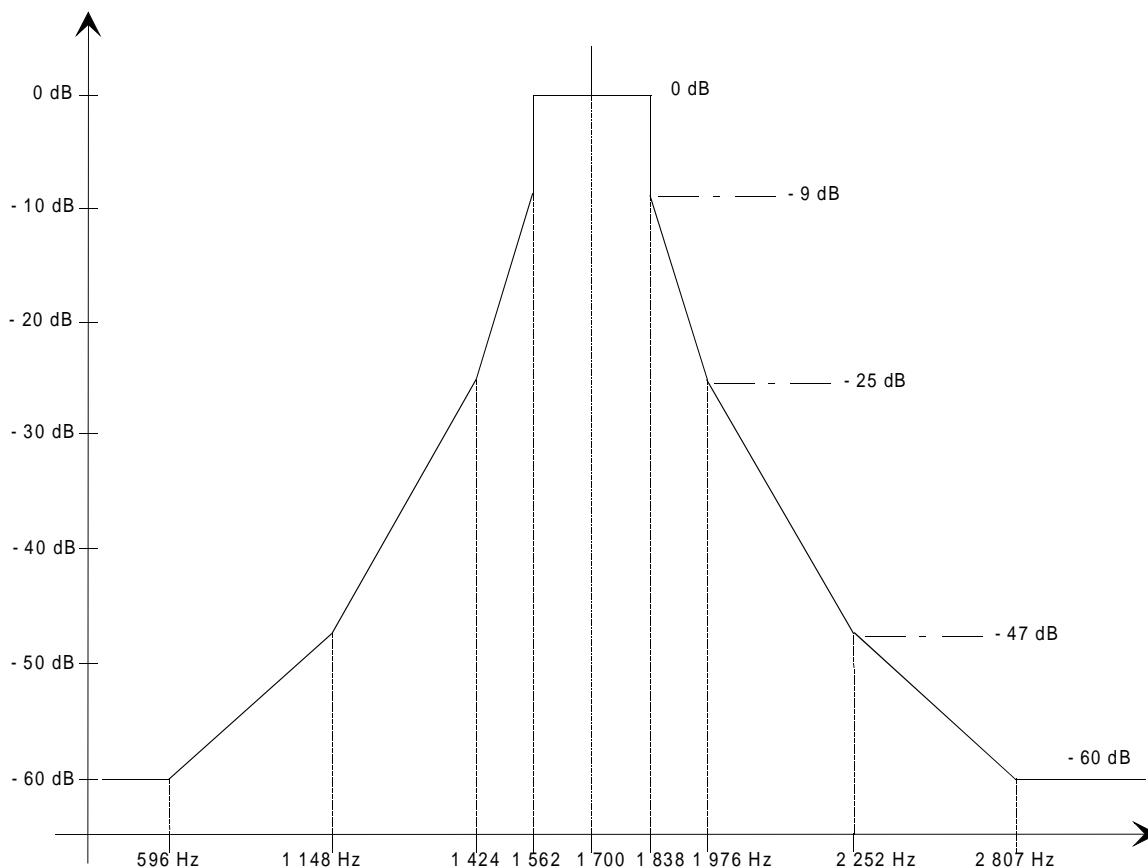

Figure 4: Unwanted spectral components (MF/HF DSC encoder)

7.5 Testing of generated call sequences

The output of the equipment shall be connected to calibrated apparatus for decoding and printing out the information content of the call sequences generated by the equipment.

The equipment shall be set to transmit DSC calls as specified in annex A in order to verify that the requirements of ITU-R Recommendation M.493-6 [4] regarding message composition and content are met.

The generated calls shall be analysed with the calibrated apparatus for correct configuration of the signal format, including time diversity.

The telecommands used shall be stated in the test report.

7.6 Residual frequency modulation

7.6.1 Definition

The residual frequency modulation level is the ratio in dB of the audio-frequency power produced after demodulation of the RF signal in the absence of wanted modulation to the audio-frequency output power produced by the transmission of a continuous dot pattern.

7.6.2 Method of measurement

The RF output terminal of the equipment shall be connected to a linear FM demodulator. The output of the demodulator shall be limited in bandwidth by a low-pass filter with a cut-off frequency of 1 kHz and a slope of 12 dB/octave.

The rms output level shall be measured during no transmission and during transmission of continuous dot pattern. For integrated VHF equipment, the rms output level shall be measured during transmission of an unmodulated carrier and during transmission of continuous dot pattern.

7.6.3 Limits

For non-integrated equipment the residual modulation shall not be > -36 dB. For integrated equipment the residual modulation ratio shall not be > -36 dB.

8 VHF DSC encoder

8.1 Frequency error

8.1.1 Definition

The frequency error is the difference between the measured frequency and its nominal value.

8.1.2 Method of measurements

The measurement shall be carried out under normal test conditions (subclause 4.9) and under extreme test conditions (subclauses 4.10.1 and 4.10.3 applied simultaneously).

A non-reactive load of 600Ω shall be connected to the output terminal of the equipment. The frequencies corresponding to the B - state and the Y - state (ITU-R Recommendation M.493-6 [4], Annex I, subclause 1.4) shall be measured on the output terminal. The encoder shall be set to generate continuous B or Y signal.

8.1.3 Limits

The measured frequency following after the warming up period (see subclause 3.12) shall at any time for the B state be within ± 10 Hz relative to $1\,700 \text{ Hz} + 400 \text{ Hz}$ and for the Y state be within ± 10 Hz relative to $1\,700 \text{ Hz} - 400 \text{ Hz}$.

8.2 Output voltage

8.2.1 Definition

The output voltage is the audio voltage measured across a non-reactive load of 600 Ω . For binary output, this voltage is the level of the "1" and the "0".

8.2.2 Method of measurement

A non-reactive load of 600 Ω shall be connected to the output terminal of the equipment.

The equipment shall be set to transmit continuous dot pattern, and the rms output voltage during the dot pattern shall be measured.

8.2.3 Limits

8.2.3.1 Analogue voltage

The output voltage shall be adjustable by at least ± 10 dB from 0,775 V (rms).

The output level of the two tones shall not vary by more than 0,5 dB during the transmission of an information block or control signal and each tone shall be within 0,5 dB relative to the other.

8.2.3.2 Binary voltage

The levels of the output voltage shall conform with NMEA 0183, Version 2.0.0 [7].

8.3 Bit stream speed

8.3.1 Definition

The bit stream speed is the number of bits per second.

8.3.2 Method of measurement

The equipment shall be set to transmit a continuous dot pattern.

The output terminal of the equipment shall be connected to a linear FM demodulator. The output of the demodulator shall be limited in bandwidth by a low pass filter with a cut-off frequency of 1 kHz and a slope of 12 dB/octave.

The frequency of the dot pattern shall be measured.

8.3.3 Limits

The frequency shall be 600 Hz \pm 30 ppm corresponding to a bit stream speed of 1 200 baud.

8.4 Unwanted spectral components of the output signal

8.4.1 Definition

Unwanted spectral components are emissions on a frequency or frequencies which are outside the necessary bandwidth and the level of which may be reduced without affecting the corresponding transmission of information. Unwanted spectral components include harmonic spectral components and intermodulation products.

8.4.2 Method of measurement

The output terminals of the equipment shall be connected to a non-reactive load of 600 Ω .

The equipment shall be set to transmit a continuous dot pattern.

The unwanted spectral components in the output signal shall be determined.

8.4.3 Limits

The unwanted spectral components shall fulfil the requirement in figure 5, 0 dB refers to the registered mean power output level.

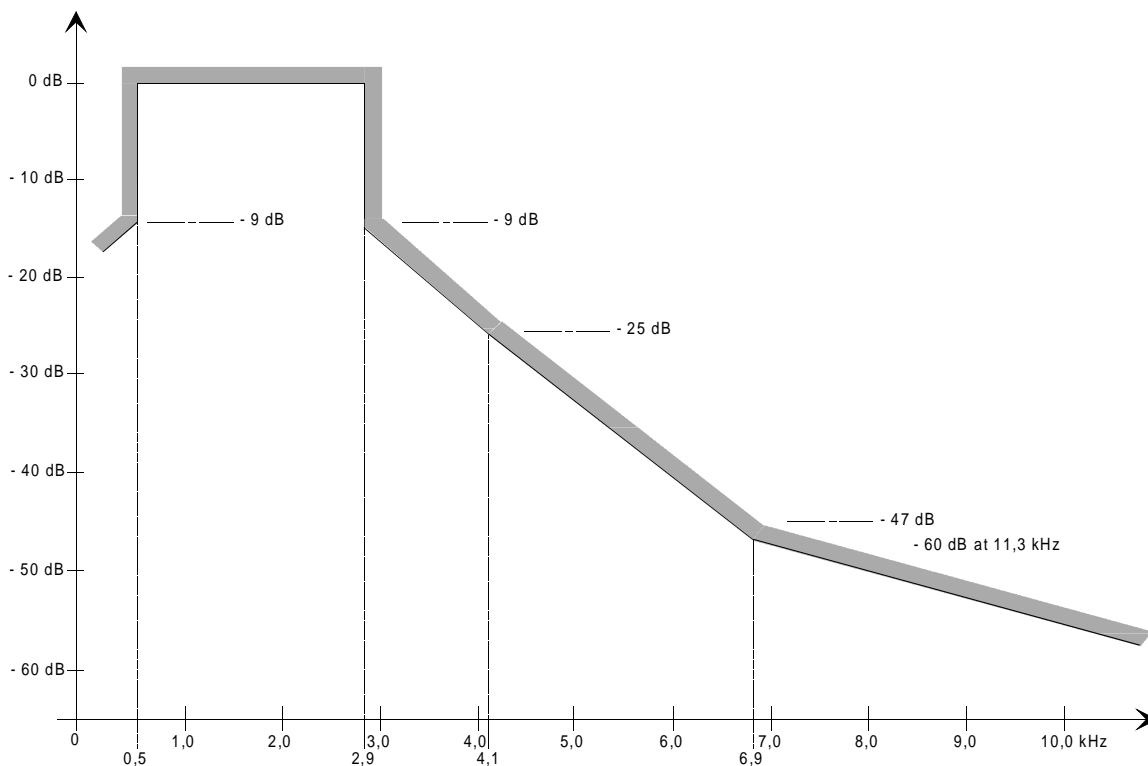

Figure 5: Unwanted spectral components /VHF DSC encoder)

8.5 Testing of generated call sequences

The output of the equipment shall be connected to calibrated apparatus for decoding and printing out the information content of the call sequences generated by the equipment.

The equipment shall be set to transmit DSC calls as specified in annex A in order to verify that the requirements of ITU-R Recommendation M.493-6 [4] regarding message composition and content are met.

The generated calls shall be analysed with the calibrated apparatus for correct configuration of the signal format, including time diversity.

The telecommands used shall be stated in the test report.

8.6 Residual frequency modulation

8.6.1 Definition

The residual frequency modulation level is the ratio in dB between the noise power during the emission of a continuous B or Y signal and the output power while emitting continuous dot pattern.

8.6.2 Method of measurement

The output terminal of the equipment shall be terminated with a non-reactive load of 600 Ω and fed to a linear FM demodulator. The output of the demodulator shall be limited in bandwidth by a low-pass filter with a cut-off frequency of 3 kHz and a slope of 12 dB/octave.

The rms output levels shall be measured during emission of the B or Y signals and during the emission of a continuous dot pattern.

The ratio of the two rms output levels from the demodulator shall be determined.

DC voltages shall be suppressed by an ac coupling device so that they do not influence the results of the measurements.

8.6.3 Limits

The residual analogue frequency modulation ratio shall not be greater than - 36 dB.

9 MF/HF receiver with integrated DSC decoder

9.1 Scanning watch receiver efficiency

9.1.1 Definition

Scanning efficiency is the ability of the receiver/decoder to correctly receive calls preceded by more than 20 bits of a 200 bit dot pattern and transmitted on one frequency whilst scanning up to six frequencies ignoring all other signals and noise.

9.1.2 Method of measurement

Two RF test signals with a level of 20 dB μ V shall be applied to the receiver.

One of the RF signals shall have a nominal frequency corresponding to a frequency in the scanning sequence and be standard test signal no. 1 containing a single DSC distress call.

The other RF signal shall have a nominal frequency corresponding to another frequency being scanned. It shall be standard test signal no. 1 containing DSC calls with 20 bit dot pattern.

The distress call sequences shall be repeated after a random interval of 2,5 to 4,0 s.

The receiver shall be set to scan the maximum number of frequencies for which it is designed.

The number of transmitted distress calls shall be 200 and the symbol error rate shall be determined as described in subclause 4.4.

9.1.3 Limits

The total number of received distress calls shall be equal to or exceed 95 % of distress calls transmitted and the symbol error rate shall be $\leq 10^{-2}$.

9.2 Calling sensitivity

9.2.1 Definition

The calling sensitivity of the receiver is a defined RF signal level at which the receiver gives a symbol error rate better than or equal to 10^{-2} .

9.2.2 Method of measurement

The receiver input terminal shall be connected to the artificial antenna specified in subclause 4.5 and the standard test signal no. 1 containing DSC calls shall be applied. The level of the test signal shall be 0 dB μ V for receiving frequencies in the bands 415 kHz to 526,5 kHz and 1,6 MHz to 27,5 MHz at the beginning of the test.

The symbol error rate in the decoder output shall be determined as described in subclause 4.4.

The input level shall be reduced until the symbol error rate is equal to or less than 10^{-2} , this level shall be recorded.

The measurement shall be repeated at the nominal input frequency ± 10 Hz.

The measurements shall be carried out under normal test conditions (subclause 4.9) and under extreme test conditions (subclauses 4.10.1 and 4.10.3 applied simultaneously).

9.2.3 Limits

The sensitivity shall be less than 0 dB μ V under normal and better than 6 dB μ V under extreme conditions.

9.3 Adjacent channel selectivity

9.3.1 Definition

Adjacent channel selectivity is defined as the suppression of an unwanted signal, expressed as the symbol error rate caused by the unwanted signal in the output from the decoder.

9.3.2 Method of measurement

The arrangements for applying the test signals shall be in accordance with subclause 4.6.

The wanted RF signal shall be standard test signal no. 1 containing DSC calls, and the level of the wanted signal shall be 20 dB μ V.

The unwanted signal shall be an unmodulated signal at the frequency + 500 Hz and then - 500 Hz relative to the nominal frequency of the receiver (centre frequency).

The symbol error rate in the decoder output shall be determined as described in subclause 4.4.

The level of the unwanted signal shall then be increased until the symbol error rate is equal to 10^{-2} , this level shall be recorded.

The measurement shall be carried out under normal test conditions (subclause 4.9) and under extreme test conditions (subclauses 4.10.1 and 4.10.3 applied simultaneously).

9.3.3 Limits

The level of the unwanted signal shall not be less than 60 dB μ V under normal test conditions and not less than 54 dB μ V under extreme test conditions.

9.4 Co-channel rejection

9.4.1 Definition

The co-channel rejection is the ability of the receiver to receive a wanted signal in the presence of an unwanted signal, both signals being on the wanted channel of the receiver.

9.4.2 Method of measurements

The arrangements for applying the test signals shall be in accordance with subclause 4.6.

The wanted signal shall be standard test signal no. 1, containing DSC calls, and the level of the wanted signal shall be 20 dB μ V.

The unwanted signal shall be unmodulated.

The symbol error rate in the decoder output shall be determined as described in subclause 4.4.

The input level of the unwanted signal shall be increased until the symbol error rate is equal to 10^{-2} , this level shall be recorded.

9.4.3 Limits

The level of the unwanted signal shall not be less than 14 dB μ V.

9.5 RF intermodulation response

9.5.1 Definition

The RF intermodulation response is defined as the rejection of intermodulation products originating from two unwanted signals with given levels and frequencies, expressed as that level at which the symbol error rate is 10^{-2} .

9.5.2 Method of measurement

The signals applied to the receiver input shall be connected in accordance with subclause 4.6.

The wanted signal shall be standard test signal no. 1, containing DSC calls, and the level of the wanted signal shall be 20 dB μ V.

The two unwanted signals are both unmodulated and at the same level. Neither of the two signals shall be at a frequency nearer to the wanted signal than 30 kHz (frequency combinations capable of resulting in unwanted intermodulation products are given in ITU-R Recommendation SM.332-4 [8], section 6.4).

The symbol error rate in the decoder output shall be determined as described in subclause 4.4.

The levels of the two unwanted signals shall then be increased together until the symbol error rate is 10^{-2} , this level shall be recorded.

9.5.3 Limits

The levels of the unwanted signals shall not be less than 70 dB μ V.

9.6 Interference rejection and blocking immunity

9.6.1 Definition

The interference rejection and blocking immunity is the ability of the receiver to discriminate between a wanted signal and unwanted signals with frequencies outside the passband of the receiver.

9.6.2 Method of measurement

The wanted signal and an unmodulated unwanted signal shall be applied to the receiver input in accordance with subclause 4.6.

The wanted signal shall be standard test signal no. 1, containing DSC calls, and the level of the wanted signal shall be 20 dB μ V.

The symbol error rate in the decoder output shall be determined as described in subclause 4.4.

The input level of the unwanted signal shall be increased until the symbol error rate is 10^{-2} , this level shall be recorded.

9.6.3 Limits

The level of the unwanted signal shall not be less than 60 dB μ V for frequencies from + 1 kHz to + 3 kHz and from - 1 kHz to - 3 kHz relative to the nominal frequency. The level of the unwanted signal shall not be less than 90 dB μ V for frequencies from 9 kHz to 2 GHz with the exception of the frequency band \pm 3 kHz from the nominal frequency.

9.7 Dynamic range

9.7.1 Definition

The dynamic range of the equipment is the range from the minimum to the maximum level, of a radio frequency input signal at which the symbol error rate in the output of the decoder does not exceed a specified value.

9.7.2 Method of measurement

Standard test signal no. 1, containing DSC calls, shall be applied to the receiver input. The level of the DSC calls shall alternate between 80 dB μ V and 0 dB μ V.

The symbol error rate in the decoder output shall be determined as described in subclause 4.4.

9.7.3 Limits

The symbol error rate in the decoded call sequences shall be 1×10^{-2} or less.

9.8 Conducted spurious emissions

9.8.1 Definition

Conducted spurious emissions are all internally generated signals conducted to the antenna terminal, irrespective of the frequency.

9.8.2 Method of measurement

The receiver input shall be connected to the artificial antenna specified in subclause 4.5, and the spurious emissions shall be measured, using a selective measuring instrument. The rms value of any component of the spurious emission is then evaluated.

The measurement shall be made over the frequency range from 9 kHz to 2 GHz.

The bandwidth of the selective analyser shall be:

- 200 Hz in the frequency range from 9 kHz to 150 kHz;
- 9 to 10 kHz in the frequency band from 150 kHz to 30 MHz;
- 100 to 120 kHz in the frequency band 30 MHz to 1 GHz;
- 1 MHz above 1 GHz.

The detector shall be a peak detector.

9.8.3 Limits

The power of any discrete frequency component shall not exceed 2 nW.

9.9 Verification of correct decoding of various types of digital selective calls

The input terminal of the equipment shall be connected to a calibrated apparatus for generation of DSC signals.

DSC calls as specified in annex A shall be applied to the equipment to verify that the requirements of ITU-R Recommendation M.493-6 [4] regarding message composition and content are met.

The decoded call sequences at the output of the equipment shall be examined for correct technical format, including error-check character.

When decoder measurements are made by use of a printer or a computer, a check shall be made to ensure accordance between printer output and display indication.

The telecommands used shall be stated in the test report.

9.10 Protection of receiver antenna input circuits

The receiver shall not suffer damage when a unmodulated radio frequency test signal at a level of 30 volts rms at any frequency in the range 100 kHz to 27,5 MHz is applied to its input terminals for a period of 15 minutes in accordance with subclause 4.6. The receiver shall operate normally without further attention when the test signal is removed.

In order to provide protection against damage due to static voltages which may appear at the input at the receiver, there shall be a dc path from the antenna terminal to chassis not exceeding 100 k Ω .

10 VHF receiver with integrated DSC decoder

10.1 Maximum usable sensitivity

10.1.1 Definition

The maximum usable sensitivity of the receiver is the minimum level of the signal (emf) at the nominal frequency of the receiver which when applied to the receiver input with a test modulation will produce a symbol error rate of 10^{-2} .

10.1.2 Method of measurement

Standard test signal no. 4 containing DSC calls shall be applied to the receiver input.

The symbol error rate in the decoder output shall be determined as described in subclause 4.4.

The input level shall be reduced until the symbol error rate is 10^{-2} , this level shall be recorded.

The measurement shall be carried out under normal test conditions (subclause 4.9) and under extreme test conditions (subclauses 4.10.1 and 4.10.3 applied simultaneously).

The measurement shall be repeated under normal test conditions at the nominal carrier frequency $\pm 1,5$ kHz.

10.1.3 Limits

The maximum usable sensitivity shall be better than or equal to 0 dB μ V under normal test conditions and better than + 6 dB μ V under extreme test conditions.

10.2 Co-channel rejection

10.2.1 Definition

The co-channel rejection is a measure of the capability of the receiver to receive a wanted modulated signal without exceeding a given degradation due to the presence of an unwanted modulated signal, both signals being at nominal frequency of the receiver.

10.2.2 Method of measurement

The two input signals shall be connected to the receiver input terminal via a combining network (see subclause 4.6). The wanted signal shall be standard test signal No. 4, containing DSC calls. The level of the wanted signal shall be + 3 dB μ V. The unwanted signal shall be modulated by 400 Hz with a deviation of ± 3 kHz. Both input signals shall be at the nominal frequency of the receiver under test and the measurement shall be repeated for displacements of the unwanted signal of up to ± 3 kHz.

The symbol error rate in the decoder output shall be determined as described in subclause 4.4.

The input level of the unwanted signal shall be increased until the symbol error rate is 10^{-2} , this level shall be recorded.

10.2.3 Limits

The unwanted signal shall be at a level of at least -5 dB μ V.

10.3 Adjacent channel selectivity

10.3.1 Definition

The adjacent channel selectivity is a measure of the capability of the receiver to receive a wanted modulated signal without exceeding a given degradation due to the presence of an unwanted modulated signal which differs in frequency from the wanted signal by 25 kHz.

10.3.2 Method of measurement

The two input signals shall be connected to the receiver input terminal via a combining network (subclause 4.6). The wanted signal shall be standard test signal No. 4, containing DSC calls. The level of the wanted signal shall be + 3 dB μ V. The unwanted signal shall be modulated by 400 Hz with a deviation of \pm 3 kHz. The unwanted signal shall be tuned to the centre frequency of the upper adjacent channels.

The symbol error rate in the decoder output shall be determined as described in subclause 4.4.

The input level of the unwanted signal shall be increased until the symbol error rate is 10^{-2} , this level shall be recorded.

The measurement shall be repeated with the unwanted signal tuned to the centre frequency of the lower adjacent channel.

The measurement shall be carried out under normal test conditions (subclause 4.9) and under extreme test conditions (subclauses 4.10.1 and 4.10.3 applied simultaneously).

10.3.3 Limits

The unwanted signal shall be at a level of at least 73 dB μ V under normal test conditions and at least 63 dB μ V under extreme test conditions.

10.4 Spurious response and blocking immunity

10.4.1 Definition

The spurious response and blocking immunity is a measure of the capability of the receiver to receive a wanted modulated signal without exceeding a given degradation due to the presence of an unwanted modulated signal with frequencies outside the passband of the receiver.

10.4.2 Method of measurement

The two input signals shall be connected to the receiver input terminal via a combining network (subclause 4.6). The wanted signal shall be standard test signal no. 4, containing DSC calls. The level of the wanted signal shall be + 3 dB μ V.

For blocking test the unwanted signal shall be unmodulated. The frequency shall be varied between - 10 MHz and - 1 MHz and also between + 1 MHz and + 10 MHz relative to the nominal frequency of the wanted signal.

For spurious response test the unwanted signal shall be unmodulated. The frequency shall be varied over the range 9 kHz to 2 GHz with the exception of the channel of the wanted signal and its adjacent channels.

The symbol error rate in the decoder output shall be determined as described in subclause 4.4.

Where blocking or spurious response occurs, the input level of the unwanted signal shall be increased until the symbol error rate is 10^{-2} , this level shall be recorded.

The measurement shall be repeated with the unwanted signal tuned to the centre frequency of the lower adjacent channel.

10.4.3 Limits

The unwanted signal shall be at a level of at least 93 dB μ V for blocking requirement.

Where spurious response occurs, the unwanted signal level shall be at least 73 dB μ V.

10.5 Intermodulation response

10.5.1 Definition

The intermodulation response is a measure of the capability of the receiver to receive a wanted modulated signal without exceeding a given degradation due to the presence of two or more unwanted signals with a specific frequency relationship to the wanted signal frequency.

10.5.2 Method of measurement

The three input signals shall be connected to the receiver input terminal via a combining network (see subclause 4.6). The wanted signal represented by signal generator A shall be at the nominal frequency of the receiver and shall be standard test signal no. 4, containing DSC calls. The level of the wanted signal shall be + 3 dB μ V.

The unwanted signals shall be applied, both at the same level. The unwanted signal from signal generator B shall be unmodulated and adjusted to a frequency 50 kHz above (or below) the nominal frequency of the receiver. The second unwanted signal from signal generator C shall be modulated by 400 Hz with a deviation of ± 3 kHz and adjusted to a frequency 100 kHz above (or below) the nominal frequency of the receiver.

The symbol error rate in the decoder output shall be determined as described in subclause 4.4.

The input level of the unwanted signals shall be increased together until the symbol error rate is 10^{-2} , this level shall be recorded.

10.5.3 Limits

The unwanted signals shall be at a level of at least 68 dB μ V.

10.6 Dynamic range

10.6.1 Definition

The dynamic range of the equipment is the range from the minimum to the maximum level, of a radio frequency input signal at which the symbol error rate in the output of the decoder does not exceed a specified value.

10.6.2 Method of measurement

A test signal in accordance with standard test signal no. 4 containing consecutive DSC calls, shall be applied to the receiver input. The level of the test signal shall alternate between 100 dB μ V and 0 dB μ V.

The symbol error rate in the decoder output shall be determined as described in subclause 4.4.

10.6.3 Limit

The symbol error rate in the decoded call sequence shall be 10^{-2} or less.

10.7 Conducted spurious emissions

10.7.1 Definition

Conducted spurious emissions are all internally generated signals conducted to the antenna terminal, irrespective of the frequency.

10.7.2 Method of measurement

The receiver input is connected to the artificial antenna specified in subclause 4.5, and the spurious emission is measured, using a selective measuring instrument. The rms value of any component of the spurious emission is then evaluated.

The measurement is made over the frequency range from 9 kHz to 2 GHz.

The bandwidth of the selective analyser shall be:

- 200 Hz in the frequency range from 9 kHz to 150 kHz;
- 9 to 10 kHz in the frequency band from 150 kHz to 30 MHz;
- 100 to 120 kHz in the frequency band 30 MHz to 1 GHz;
- 1 MHz above 1 GHz.

The detector shall be a peak detector.

10.7.3 Limit

The power of any discrete frequency component shall not exceed 2 nW.

10.8 Verification of correct decoding of various types of digital selective calls

The input terminal of the equipment shall be connected to a calibrated apparatus for generation of digital selective call signals.

DSC calls as specified in annex A shall be applied to the equipment to verify that the requirements of ITU-R Recommendation M.493-6 [4] regarding message composition and content are met.

The decoded call sequences at the output of the equipment shall be examined for correct technical format, including error-check character.

When receiver measurements are made by use of a printer or a computer, a check shall be made to ensure accordance between printer output and display indication.

The telecommands used shall be stated in the test report.

11 MF/HF DSC decoder

11.1 Interface for scanning

If the MF/HF DSC decoder is intended to be used with an MF/HF receiver for reception of digital selective calls with facilities for scanning six digital selective calling channels (subclause 9.1), the decoder shall fulfil the following requirements:

- the decoder shall provide a suitable signal to stop the scanning process automatically only on detection of a 100 baud dot pattern of more than 20 bits length;
- means shall be provided at the MF/HF receiver to transmit information of the frequency or channel on which scanning has stopped using NMEA 0183, Version 2.0.0 [7] protocol. The frequency or channel shall be displayed or printed in relation to the DSC call received;

- the decoder shall provide a suitable signal to restart the scanning process after receipt of a DSC call or, during the reception of a DSC call which is not addressed to the ship, as soon as it is recognised as not being addressed to the ship;
- the stop signal shall be logic "0" and the start signal shall be logic "1" with levels complying with NMEA 0183, Version 2.0.0 [7];
- the stop and restart signals may be substituted by direct frequency setting of the scanning receiver by the DSC equipment using NMEA 0183, Version 2.0.0 [7] protocol.

11.2 Scanning efficiency

11.2.1 Definition

Scanning efficiency is the ability of the decoder to correctly identify calls preceded by more than 20 bits of a 200 bit dot pattern ignoring all other signals and noise and generate suitable signals to control an associated scanning receiver.

11.2.2 Method of measurement

Two standard test signals no. 1 or no. 2 containing a series of call sequences shall be applied alternately to the receiver at random time intervals.

One standard test signal shall be a single distress call. The other standard test signal shall contain DSC calls with a 20 bit dot pattern.

The number of transmitted distress calls shall be 200 and the symbol error rate shall be determined as described in subclause 4.4.

11.2.3 Limits

The total number of received distress calls shall be equal to or exceed 95 % of distress calls transmitted and the symbol error rate shall be $\leq 10^{-2}$.

11.3 Dynamic range

11.3.1 Definition

The dynamic range of the decoder is the range from the minimum to the maximum audio frequency level at which a message shall be decoded without errors.

For a binary input the dynamic range is the differential input voltage necessary to assume correctly the intended binary state.

11.3.2 Method of measurement

11.3.2.1 Analogue voltage

Standard test signal no. 1 which shall be varied by ± 10 dB relative to 0,775 V rms shall be applied to the input terminal of the equipment.

If the equipment is provided with a preset control for adjustment to different audio frequency input levels, this shall be set to correspond to the input level for which the equipment is designed (see subclause 3.1.2).

The centre frequency of the test signal shall during the test periodically be changed to a value ± 20 Hz relative to its nominal value.

11.3.2.2 Binary voltage

Standard test signal no. 2 which shall be varied over the entire common-mode voltage range of + 7 V to - 7 V with a differential input voltage of $\geq 2,0$ V shall be applied to the input terminals of the equipment.

The symbol error rate in the decoder output shall be determined as described in subclause 4.4.

The measurements shall be carried out under normal test conditions (subclause 4.9) and under extreme test conditions (subclauses 4.10.1 and 4.10.3 applied simultaneously).

11.3.3 Limits

Within the stated voltage range the DSC calls shall be decoded without errors.

11.4 Verification of correct decoding of various types of digital selective calls

The input terminal of the equipment shall be connected to a calibrated apparatus for generation of digital selective call signals.

DSC calls as specified in annex A shall be applied to the equipment to verify that the requirements of ITU-R Recommendation M.493-6 [4] regarding message composition and content are met.

The decoded call sequences at the output of the equipment shall be examined for correct technical format, including error-check character.

When decoder measurements are made by use of a printer or a computer, a check shall be made to ensure accordance between printer output and display indication.

The telecommands used shall be stated in the test report.

12 VHF DSC decoder

12.1 Dynamic range

12.1.1 Definition

The dynamic range of the equipment is the range from the minimum to the maximum audio frequency signal level at which a message shall be decoded without errors.

For a binary input the dynamic range is the differential input voltage necessary to assume correctly the intended binary state.

12.1.2 Method of measurement

12.1.2.1 Analogue voltage

Standard test signal no. 1 which shall be varied by ± 10 dB relative to 0,775 V rms shall be applied to the input terminal of the equipment.

If the equipment is provided with a preset control for adjustment to different analogue-frequency input levels, this shall be set to correspond to the input level for which the equipment is designed (see subclause 3.1.2).

The centre frequency of the test signal shall during the test periodically be changed to a value ± 20 Hz relative to its nominal value.

12.1.2.2 Binary voltage

Standard test signal no. 2 which shall be varied over the entire common-mode voltage range of + 7 V to - 7 V with a differential input voltage of $\geq 2,0$ V shall be applied to the input terminals of the equipment.

The symbol error rate in the decoder output shall be determined as described in subclause 4.4.

The measurements shall be carried out under normal test conditions (subclause 4.9) and under extreme test conditions (subclauses 4.10.1 and 4.10.3 applied simultaneously).

12.1.3 Limits

Within the stated voltage range the DSC calls shall be decoded without errors.

12.2 Verification of correct decoding of various types of digital selective calls

The input terminal of the equipment shall be connected to a calibrated apparatus for generation of DSC signals.

DSC calls as specified in annex A shall be applied to the equipment to verify that the requirements of ITU-R Recommendation M.493-6 [4] regarding message composition and content are met.

The decoded call sequences at the output of the equipment shall be examined for correct technical format, including error-check character.

When decoder measurements are made by use of a printer or a computer, a check shall be made to ensure accordance between printer output and display indication.

The telecommands used shall be stated in the test report.

Annex A (normative): Test calls

A.1 Types of calls to be tested

Table A.1: Test calls

Type of call	Receive	Transmit
EPIRB emission	X	-
Distress call, no information	X	X
Distress call, with position in each of the 4 quadrants	-	X
Distress call, with position in each of the 4 quadrants and different nature of distress	X	X (note 1)
Distress acknowledgement	X	X
Distress relay call, to individual coast stations	X	X
Distress relay call, to geographic area in each of the 4 quadrants	X	-
Distress relay call, to all ships with position inserted automatically and manually in each of the 4 quadrants	X	X
Distress relay acknowledgement	X	-
Urgency call, to individual ship stations	-	X
Urgency call, to a group of stations	X (note 1)	-
Urgency call, to all ships	X	-
Safety call, to individual ship stations	X	-
Safety call, to geographic area	X (note 1)	-
Safety call, to all ships	-	X
Ship's business call, to individual station	X	X
Routine call, to individual stations	X	X
Routine call, to group of stations	-	X (note 1)
Routine call, to geographic area	-	X (note 1)
Semi-automatic/automatic service call (note 2)	X (note 3)	X
Acknowledgement, able to comply	X	X (note 1)
Acknowledgement, unable to comply	X	X
Polling call	X	X
Ship's position or location updating call	X	X
Test call (note 4)	X (note 5)	X
Symbols: X = Type of call to be tested. - = Type of call not required to be tested NOTE 1: Test required for Class A equipment only. NOTE 2: Also ring-back and end-of-call to be tested. NOTE 3: One of each call containing frequency, channel and position information shall be tested. NOTE 4: Applicable to MF/HF equipment only. NOTE 5: Acknowledgements only.		

A.2 Telecommands applicable to DSC shipborne equipment

Tests shall be performed using a selection of the following applicable, underlined telecommands.

A.2.1 Class A, MF/HF equipment

First telecommand symbol no: 103, 104, 105, 106, 109, 110, 111, 112, 113, 115, 116, 118, 119, 120, 121, 123, 124 and 126.

Second telecommand symbol no: 100, 102, 104, 105, 106, 107, 108, 109, 110, 111, 112, 115, 116, 118, 119, 120, 121, 123, 124 and 126.

A.2.2 Class A, VHF equipment

First telecommand symbol no: 100, 101, 103, 104, 105, 106, 110, 112, 116, 119, 121, 124 and 126.

Second telecommand symbol no: 100, 102, 104, 105, 106, 107, 108, 109, 110, 111, 112, 115, 116, 118, 119, 120, 121, 123, 124 and 126.

A.2.3 Class B, MF equipment

First telecommand symbol no: 105, 109, 110, 111, 112, 118 and 126 and receive only 104.

Second telecommand symbol no: 109, 111 and 126 and receive only 100, 102, 103, 104, 105, 106 107 108 and 109.

A.2.4 Class B, VHF equipment

First telecommand symbol no: 100, 101, 105, 110, 112 and 126 and receive only 104.

Second telecommand symbol no: 110, 111 and 126 and receive only 100, 102, 104, 105, 106, 107, 108 and 109.

A.2.5 Class D

First telecommand symbol no: 100, 126 and receive only 104, 110 and 112.

Second telecommand symbol no: 126 and receive only 100, 102, 103, 104, 105, 106, 107, 108 and 109.

A.2.6 Class E

First telecommand symbol no: 109, 111 and 126 and receive only 104, 110 and 112.

A.2.7 Class F

First telecommand symbol no: 100 and receive only 110.

Second telecommand symbol no: 126.

A.2.8 Class G

First telecommand symbol no: 109 and 111 and receive only 110.

Second telecommand symbol no: 126.

Annex B (normative): Specifications for adjacent channel power measurement arrangements

B.1 Power measuring receiver specification

The power measuring receiver consists of a mixer, an IF filter, an oscillator, an amplifier, a variable attenuator, and an rms value indicator. Instead of the variable attenuator with the rms value indicator it is also possible to use an rms voltmeter calibrated in dB. The technical characteristics of the power measuring receiver are given in subclauses B.1.1 to B.1.4.

B.1.1 IF filter

The IF filter shall be within the limits of the selectivity characteristics shown in figure B.1.

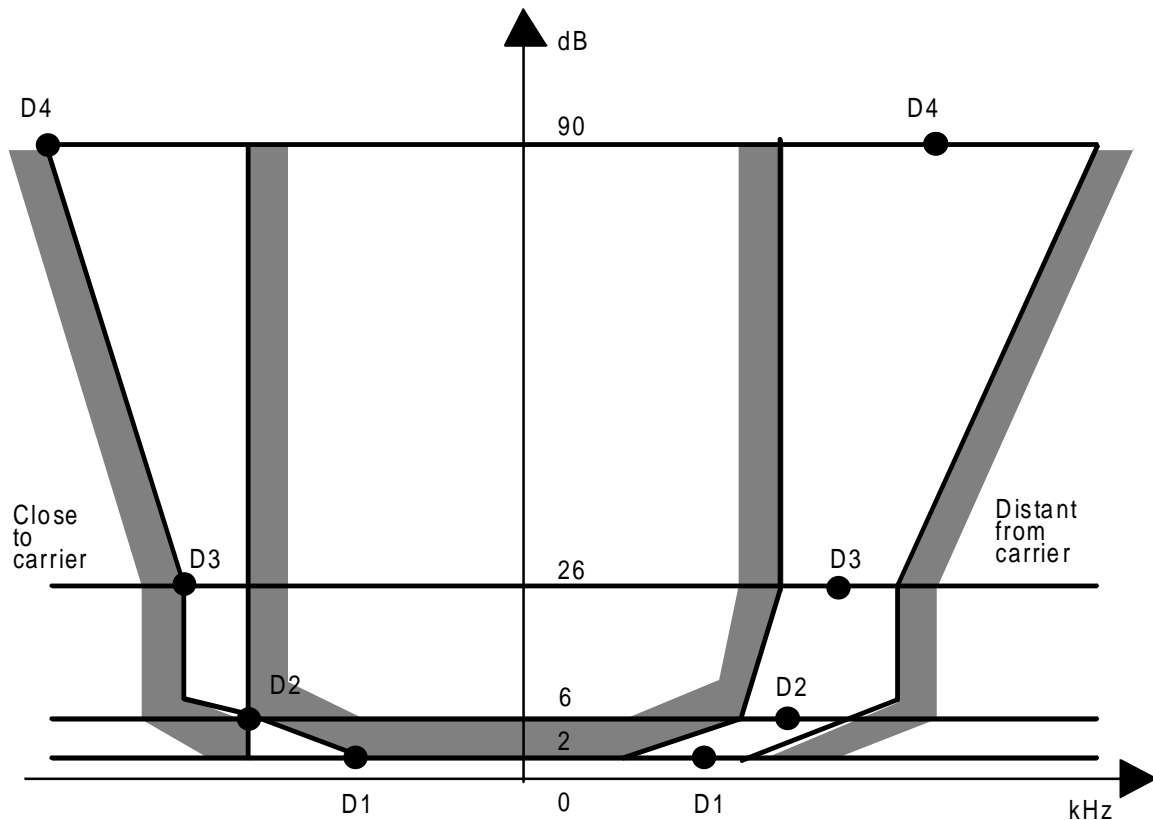

Figure B.1

The selectivity characteristic shall keep the following frequency separations from the nominal centre frequency of the adjacent channel as given in column 2 of table B.1.

The attenuation points on the slope towards the carrier shall not exceed the tolerances, as given in column 3 of table B.1.

The attenuation points on the slope, distant from carrier, shall not exceed the tolerances, as given in column 4 of table B.1.

Table B.1: Selectivity characteristic of the "receiver"

Attenuation points	Frequency separation	Tolerance towards C	Tolerance distant from C
D1 (2 dB)	5,00 kHz	+ 3,10 kHz	± 3,50 kHz
D2 (6 dB)	8,00 kHz	± 0,10 kHz	± 3,50 kHz
D3 (26 dB)	9,25 kHz	- 1,35 kHz	± 3,50 kHz
D4 (90 dB)	13,25 kHz	- 5,35 kHz	+ 3,5 kHz and - 7,5 kHz

The minimum attenuation of the filter outside the 90 dB attenuation points shall be equal to or greater than 90 dB.

B.1.2 Attenuation indicator

The attenuation indicator shall have a minimum range of 80 dB and a reading accuracy of 1 dB. With a view to future regulations an attenuation of 90 dB or more is recommended.

B.1.3 Rms value indicator

The instrument shall accurately indicate non-sinusoidal signals in a ratio of up to 10:1 between peak value and rms value.

B.1.4 Oscillator and amplifier

The oscillator and the amplifier shall be designed in such a way that the measurement of the adjacent channel power of a low-noise unmodulated transmitter, whose self-noise has a negligible influence on the measurement result, yields a measured value of $<- 90$ dB.

History

Document history	
July 1994	Public Enquiry PE 67: 1994-07-25 to 1994-11-18
July 1995	Vote extended: V 84: 1995-07-24 to 1995-09-15 1995-07-24 to 1995-09-29
November 1995	First Edition
February 1996	Converted into Adobe Acrobat Portable Document Format (PDF)