



Operational energy Efficiency for Users (OEU); Global KPIs for Data Centres

Disclaimer

This document has been produced and approved by the Operational energy Efficiency for Users (OEU) ETSI Industry Specification Group (ISG) and represents the views of those members who participated in this ISG.
It does not necessarily represent the views of the entire ETSI membership.

Reference

RGS/OEU-007

Keywords

energy efficiency, user

ETSI

650 Route des Lucioles
F-06921 Sophia Antipolis Cedex - FRANCE

Tel.: +33 4 92 94 42 00 Fax: +33 4 93 65 47 16

Siret N° 348 623 562 00017 - NAF 742 C
Association à but non lucratif enregistrée à la
Sous-Préfecture de Grasse (06) N° 7803/88

Important notice

Individual copies of the present document can be downloaded from:

<http://www.etsi.org>

The present document may be made available in more than one electronic version or in print. In any case of existing or perceived difference in contents between such versions, the reference version is the Portable Document Format (PDF). In case of dispute, the reference shall be the printing on ETSI printers of the PDF version kept on a specific network drive within ETSI Secretariat.

Users of the present document should be aware that the document may be subject to revision or change of status. Information on the current status of this and other ETSI documents is available at

<http://portal.etsi.org/tb/status/status.asp>

If you find errors in the present document, please send your comment to one of the following services:

http://portal.etsi.org/chaicor/ETSI_support.asp

Copyright Notification

No part may be reproduced except as authorized by written permission.
The copyright and the foregoing restriction extend to reproduction in all media.

© European Telecommunications Standards Institute 2013.
All rights reserved.

DECT™, **PLUGTESTS™**, **UMTS™** and the ETSI logo are Trade Marks of ETSI registered for the benefit of its Members.
3GPP™ and **LTE™** are Trade Marks of ETSI registered for the benefit of its Members and of the 3GPP Organizational Partners.
GSM® and the GSM logo are Trade Marks registered and owned by the GSM Association.

Contents

Intellectual Property Rights	5
Foreword.....	5
Introduction	6
1 Scope	7
2 References	7
2.1 Normative references	7
2.2 Informative references.....	7
3 Definitions, symbols and abbreviations	8
3.1 Definitions.....	8
3.2 Symbols.....	8
3.3 Abbreviations	9
4 Definition of Key Performance Indicators	9
4.1 Objective KPIs for data centre operation	9
4.1.1 Energy Consumption (KPI_{EC})	9
4.1.1.1 Generalities	9
4.1.1.2 Scale	9
4.1.1.3 Evolution.....	9
4.1.1.4 Formula	10
4.1.1.5 Measurement points and processes	10
4.1.2 Task efficiency (KPI_{TE}).....	11
4.1.2.1 Generalities	11
4.1.2.2 Scale	11
4.1.2.3 Evolution.....	11
4.1.2.4 Formula	11
4.1.2.5 Measurement points and processes	11
4.1.3 Energy reuse (KPI_{REUSE})	12
4.1.3.1 Generalities	12
4.1.3.2 Definition of energy reuse.....	12
4.1.3.3 Scale	12
4.1.3.4 Evolution.....	12
4.1.3.5 Formula	12
4.1.3.6 Measurement points and processes	13
4.1.4 Use of renewable energy (KPI_{REN}).....	13
4.1.4.1 Generalities	13
4.1.4.2 Scale	13
4.1.4.3 Evolution.....	13
4.1.4.4 Formula	13
4.1.4.5 Measurement Points and processes	13
4.2 Global KPI (KPI_{DCEM}) using the Objective KPIs	14
4.2.1 Introduction.....	14
4.2.2 Scale.....	14
4.2.3 Evolution	14
4.2.4 Formula for DC_p	15
4.2.5 Measurement points and processes	15
Annex A (informative): Energy Consumption per square metre (KPI_{ECI}).....	16
A.1 Generalities.....	16
A.2 Scale	16
A.3 Evolution	16
A.4 Formula	16

A.5	Measurement points and procedures	16
Annex B (informative):	The status of Key Performance Indicators (KPIs).....	17
B.1	Technical KPIs	17
B.2	Objective KPIs	17
B.3	Global KPIs	18
B.4	Summary	18
History	19

Intellectual Property Rights

IPRs essential or potentially essential to the present document may have been declared to ETSI. The information pertaining to these essential IPRs, if any, is publicly available for **ETSI members and non-members**, and can be found in ETSI SR 000 314: *"Intellectual Property Rights (IPRs); Essential, or potentially Essential, IPRs notified to ETSI in respect of ETSI standards"*, which is available from the ETSI Secretariat. Latest updates are available on the ETSI Web server (<http://ipr.etsi.org>).

Pursuant to the ETSI IPR Policy, no investigation, including IPR searches, has been carried out by ETSI. No guarantee can be given as to the existence of other IPRs not referenced in ETSI SR 000 314 (or the updates on the ETSI Web server) which are, or may be, or may become, essential to the present document.

Foreword

This Group Specification (GS) has been produced by ETSI Industry Specification (ISG) Operational energy Efficiency for Users (OEU).

Introduction

Further to the 1997 Kyoto protocol [i.8], the European Commission has issued, and will issue, Directives in order to improve energy management of broadband networks, sites included, of whole industry sectors.

Therefore suppliers and users of information and communication technology (ICT) equipment are obliged to implement "Green" tools (indicators, recognized Green levels) to monitor the efficiency of their greener networks.

Data centres constitute one of the most important ICT area of energy consumption. Consequently, the first target of ETSI ISG OEU has been the development of this Position Paper defining appropriate technical Global Key Performance Indicators (KPIs) to be used for operational Data Centres.

The present document has been developed by ISG OEU members (ICT world Users) supported by the DTI Alliance/CRIP in order to define the most efficient tools.

The present document presents the Objective KPIs of the ES 205 200-2-1 [i.2] in a simple format and uses them to define a Global KPI which indicates data centre energy usage and efficiency. It is expected that the present document will influence the development and maintenance of the ES 205 200 Series [i.9] under the responsibility of ETSI ATTU.

Several standards or technical documents have been taken into account during the development of the present document including EC Mandate M/462 [i.1], ES 205 200-2-1 [i.2], TR 105 174-1 [i.7], TS 105 174-2-2 [i.3], the CENELEC EN 50600 Series [1], Recommendation ITU-T L.1300 [i.5], and EC DG JRC Code of Conduct for Data Centres [i.4] and [i.6].

1 Scope

The present document defines the current position of the ISG OEU members in relation to the so-called Global Key Performance Indicators (Global KPIs) enabling the monitoring of data centre (DC) energy management.

The present document defines Global Key Performance Indicators in relation to energy management for operator data centres (ODC), operator sites (OS) and customer data centres (CDC) and addresses the following objectives:

- energy consumption;
- task efficiency;
- energy reuse;
- renewable energy.

The present document defines:

- four KPIs addressing these objectives (Objective KPIs);
- one Global KPI which combines the four Objective KPIs.

The Objective and Global KPIs defined here apply to data centres or operator sites of any size from initial operation to end of life.

2 References

References are either specific (identified by date of publication and/or edition number or version number) or non-specific. For specific references, only the cited version applies. For non-specific references, the latest version of the referenced document (including any amendments) applies.

Referenced documents which are not found to be publicly available in the expected location might be found at <http://docbox.etsi.org/Reference>.

NOTE: While any hyperlinks included in this clause were valid at the time of publication, ETSI cannot guarantee their long term validity.

2.1 Normative references

The following referenced documents are necessary for the application of the present document.

- [1] CLC EN 50600 Series: "Information technology - Data centre facilities and infrastructures".
- [2] CEN EN 1434 Series: "Heat meters".

2.2 Informative references

The following referenced documents are not necessary for the application of the present document but they assist the user with regard to a particular subject area.

- [i.1] EC Mandate M/462: "Standardisation mandate addressed to CEN, CENELEC and ETSI in the field of ICT to enable efficient energy use in fixed and mobile information and communication networks".
- [i.2] ETSI ES 205 200-2-1: "Access, Terminals, Transmission and Multiplexing (ATTM); Energy management; Global KPIs; Operational infrastructures; Part 2: Specific requirements; Sub-part 1: Data centres".

- [i.3] ETSI TS 105 174-2-2: "Access, Terminals, Transmission and Multiplexing (ATTM); Broadband Deployment - Energy Efficiency and Key Performance Indicators; Part 2: Network sites; Sub-part 2: Data centres".
- [i.4] European Commission DG JRC: "Code of Conduct for Data Centre Energy Efficiency".
- [i.5] Recommendation ITU-T L.1300: "Series L: Construction, installation and protection of cables and other elements of outside plant: Best practices for green data centers".
- [i.6] European Commission DG JRC: "Code of Conduct on Energy Consumption of Broadband Equipment".
- [i.7] ETSI TR 105 174-1: "Access, Terminals, Transmission and Multiplexing (ATTM); Broadband Deployment - Energy Efficiency and Key Performance Indicators; Part 1: Overview, common and generic aspects".
- [i.8] Kyoto protocol.
- [i.9] ETSI ES 205 200 Series: "Access, Terminals, Transmission and Multiplexing (ATTM); Energy management; Global KPIs; Operational infrastructures".
- [i.10] Directive 2010/31/EU of the european parliament and of the council of 19 May 2010 on the energy performance of buildings.

3 Definitions, symbols and abbreviations

3.1 Definitions

For the purposes of the present document, the following terms and definitions apply:

energy consumption: annual energy consumption required for proper operation of the data centre, expressed as KWh, defined as "IT equipment footprint", whatever the power source is (utility or local)

energy consumption per square metre: energy consumption expressed as KWh per sqm of "occupied" IT room

fossil energy: fuel, coal, gas, etc.

Objective KPI: KPI assessing one of the objectives of operational energy performance which is subsequently used to define a Global KPI for energy management (KPI_{DCEM})

renewable energy: solar, wind, hydrothermal, geothermal, etc.

3.2 Symbols

For the purposes of the present document, the following symbols apply:

CRs	IT room floor space used (by racks, networking, disk arrays and tape robots) = raw footprint of IT and Telco equipment)
DC_G	Data Centre Gauge
DC_P	Data Centre Performance
EC_{DC}	total of energy consumptions by a data centre over a year
EC_{FEN}	total of electricity consumptions based on fossil energy
EC_{HE}	total of energy consumptions by equipment processing data, for purposes of calculating, storing or transporting, over a year
EC_{REN}	total of energy consumption from renewable sources
EC_{REUSE}	measurement of reused energy
EC_{SP}	consumption of utility electricity
EC_{TH}	energy consumption for externally-provided thermal energy (either hot or cold)
KPI_{DCEM}	Global KPI for data centre energy management
KPI_{EC}	Objective KPI for "Energy Consumption"
KPI_{ECI}	KPI for "Energy consumption per square metre"

KPI_{REN}	Objective KPI for "Renewable Energy"
KPI_{REUSE}	Objective KPI for "Energy Reuse"
KPI_{TE}	Objective KPI for "Task Efficiency"
K_{TH}	conversion ratio from electricity to thermal energy
W_{CRs}	CRs mitigation ratio; ranges from 0 to 1
W_{REN}	mitigation factor for KPI_{REN}
W_{REUSE}	mitigation factor for KPI_{REUSE}

3.3 Abbreviations

For the purposes of the present document, the following abbreviations apply:

ADEME	French Agency for Environment and Energy Management
CDC	Customer Data Centre
DC	Data Centre
EC DG JRC	European Commission Directorate General Joint Research Centre
GWh	Giga Watt Hour
ICT	Information and Communication(s) Technology
IT	Information Technology
ITE	IT Equipment
KPI	Key Performance Indicator
NTE	Network Telecommunications Equipment
ODC	Operator Data Centre
OS	Operator Site

4 Definition of Key Performance Indicators

4.1 Objective KPIs for data centre operation

4.1.1 Energy Consumption (KPI_{EC})

4.1.1.1 Generalities

The present document applies the requirements of KPI_{EC} of ES 205 200-2-1 [i.2] in a simple format. It is expected that the present document will influence the development and maintenance of the ES 205 200 Series [i.9] under the responsibility of ETSI ATTM.

The energy consumption to be included in KPI_{EC} comprises that of buildings containing IT rooms, technical infrastructure and spaces required for proper operation of the data centre (including, but not limited to: security, guards, maintenance, management of IT rooms).

Energy consumption excluded from this KPI includes buildings containing offices for on-site employees, including, but not limited to: project managers, application integrators, system experts, etc.

4.1.1.2 Scale

KPI_{EC} applies to all data centres of all sizes and includes IT rooms located in buildings.

4.1.1.3 Evolution

KPI_{EC} applies to all states of data centres, from initial operation to end of life.

4.1.1.4 Formula

$$KPI_{EC} = EC_{SP} + EC_{FEN} + EC_{REN} + (EC_{TH} \times K_{TH})$$

where:

EC_{SP} =	consumption of utility electricity
EC_{FEN} =	total of electricity consumptions based on fossil energy
EC_{REN} =	total of energy consumption from renewable sources
EC_{TH} =	energy consumption for externally-provided thermal energy (either hot or cold)
K_{TH} =	conversion ratio from electricity to thermal energy

4.1.1.5 Measurement points and processes

Utility energy (EC_{SP}):

- counter values and/or sub counters of the electricity provider feeding the site - these counters shall be certified by the electricity providers;
- electricity coming from an internal electricity distribution loop: DC input counter readings, taking into account the losses in transformers.

Electricity based on fossil local power sources (EC_{FEN}): local sub-counters readings:

- at the power sources output, when dedicated to the DC;
- at the DC entry, for power sources shared with other usages.

Energy based on renewable local power sources (EC_{REN}): local sub-counters readings:

- at the power sources output, when dedicated to the DC;
- at the DC entry, for power sources shared with other usages.

Energy based on hydrothermal energy (EC_{TH}): measured by a calories counter / integrator at the DC entry:

- according to European Norms EN 1434 Series [2] where the distribution loop is considered a closed loop;
- the same method is used for reused energy (EC_{REUSE}) - see clause 4.1.3.6.

Energy based on Aeraulics power source:

- the measurement of aeraulics-based energy is done by integrating the mass flow rate by the difference of temperature of the consuming point, the network being considered an open loop;
- the same method is used for reused energy (EC_{REUSE}) - see clause 4.1.3.6.

Remarks:

- Assessed energy consumption includes all that related to employees that are required to remain on site (guards, maintenance, management of IT rooms) since in our "ideal data centre" there would be no personnel on site, remotely managed and secured.
- No conversion of final energy consumptions into primary energy or weighting depending on the kind of power source since those aspects are dealt with in the KPI_{REN} . Nevertheless the non-electrical energy sources have to be converted in electricity equivalent in order to remain homogeneous. The conversion factor to be applied shall take into account the thermal energy origin as well as the conversion efficiency.
- When the external source is extracted by electricity and the conversion factor known and certified, it could be used as K_{TH} , using a margin to take into account the distribution losses. If not known, a default K_{TH} corresponding to a reference installation using chillers with air condensing will be used (network losses: 8 %; Energy Efficiency Ratio = 2,5 → $K_{TH} = 0,92/0,5$).

4.1.2 Task efficiency (KPI_{TE})

4.1.2.1 Generalities

The present document applies the requirements of KPI_{TE} of ES 205 200-2-1 [i.2] in a simple format. It is expected that the present document will influence the development and maintenance of the ES 205 200 Series [i.9] under the responsibility of ETSI ATTU.

KPI_{TE} is the ratio of the electricity consumption of all the components, whatever they are, to that of the components that manage data, for calculation storage or transport purposes. KPI_{TE} is dimensionless, and has the following properties:

- $KPI_{TE} \geq 1$;
- $KPI_{TE} = 1$ is an ideal value;
- a KPI_{TE} of between 2 and 2,5 is frequently reached.

All components transforming electricity or improving availability are to be taken into account.

All equipment downstream of the energy sources (including, but not limited to: lighting, cooling, safety, security, power distribution, devices extracting heat for reusing energy, devices used to extract renewable energy) are to be considered. An energy source can be either internal or external.

Should this remind the "Power Usage Effectiveness", the difference is in the definition so that everybody counts the same things.

The improvement margins allow winning several tenths. The last tenths are not attainable without changing infrastructures or technical innovations. This means the KPI_{TE} will not improve, and it is then necessary to rethink the whole data centre, including the physical part.

4.1.2.2 Scale

KPI_{TE} applies to all data centres of all sizes and includes IT rooms located in buildings.

4.1.2.3 Evolution

KPI_{TE} applies to all states of data centres, from initial operation to end of life.

4.1.2.4 Formula

$$KPI_{TE} = \frac{EC_{DC}}{EC_{HE}}$$

where:

EC_{DC} =	Total of energy consumptions by a data centre over a year.
EC_{HE} =	Total of energy consumptions by equipment processing data, for purposes of calculating, storing or transporting, over a year.

4.1.2.5 Measurement points and processes

The measurement points for electricity consumption are to be done externally to that component, nearest to its input and its output when transforming or securing.

The less near the measurement, the least favourable because will be hampered by losses in power distribution paths. Transmission losses are not taken into account by KPI_{TE} .

Measurements should be done in KWh and can be approximated by using regular power measurements.

Measurement shall be done over a yearly period, so as to take into account the yearly climate changes.

4.1.3 Energy reuse (KPI_{REUSE})

4.1.3.1 Generalities

The present document applies the requirements of KPI_{REUSE} of ES 205 200-2-1 [i.2] in a simple format. It is expected that the present document will influence the development and maintenance of the ES 205 200 Series [i.9] under the responsibility of ETSI ATTU.

KPI_{REUSE} is the ratio of reused energy for external uses to total data centre energy. Thermal energy can be reused in different forms, liquid or gas (air). KPI_{REUSE} shall be measurable and quantifiable and results in a dimensionless number.

An example is the number of hours for heating offices reusing energy, and the floor space of offices heated that way, on the basis that one square metre of office space heated at 20 °C is equivalent to 16 watts of electrical heating (see note 2).

NOTE 1: The reused energy should be mitigated by an efficiency factor depending on the heat transport system, whether air or water.

NOTE 2: Source: French Agency for Environment and Energy Management.

Extensions of KPI_{REUSE} to other kinds of energy reuse than the one described above could be studied.

4.1.3.2 Definition of energy reuse

Energy efficiency of data centres is an important matter. It is now essential if not vital to implement commitments in order to reduce the energy consumption by data centres. Indeed the ICT area is responsible for at least 2 % of the greenhouse gas emissions in the world and continues to grow.

Possible initiatives to reuse the calories produced by information technology equipment (ITE) and network telecommunications equipment (NTE) in data centres include:

- water heating;
- heating of nearby offices;
- heating of nearby apartments;
- warming of arboretums;
- pre-heating of diesel engines.

It is obvious that the viability of energy reuse will depend on data centre configurations.

4.1.3.3 Scale

KPI_{REUSE} applies to all data centres of all sizes and includes IT rooms located in buildings.

4.1.3.4 Evolution

KPI_{REUSE} applies to all states of data centres, from initial operation to end of life.

4.1.3.5 Formula

$$KPI_{REUSE} = \frac{EC_{REUSE}}{EC_{DC}}$$

where:

EC_{DC} = Total of energy consumptions by a data centre over a year.
 EC_{REUSE} = Measurement of reused energy.

4.1.3.6 Measurement points and processes

According to methodology defined in clause 4.1.1.5.

Measurement equipments shall be nearest to the reused energy consumption points so as to take into account the losses in the distribution circuits.

When using a complex distribution circuit for reuse (several scattered consumers) it is possible to locate the measuring equipment at the DC output and then apply a mitigating factor to EC_{REUSE} to take into account the losses in the distribution circuit.

When no measurement procedure is available, an approved external certification company will certify the measurement.

4.1.4 Use of renewable energy (KPI_{REN})

4.1.4.1 Generalities

The present document applies the requirements of KPI_{REN} of ES 205 200-2-1 [i.2] in a simple format. It is expected that the present document will influence the development and maintenance of the ES 205 200 Series [i.9] under the responsibility of ETSI ATTM.

KPI_{REN} is the ratio of local renewable energy over the total data centre energy consumption. It is a dimensionless number.

An energy source is considered renewable when it uses renewable natural energy and that the conventional energy required to value it is less than 10 % of the produced energy.

"energy from renewable sources" means energy from renewable non-fossil sources, namely wind, solar, aerothermal, geothermal, hydrothermal and ocean energy, hydropower, biomass, landfill gas, sewage treatment plant gas and biogases.

NOTE: According to Directive 2010/31/EU [i.10] on the Energy Performance of Building.

Only the sources contributing to data centre operations will be taken into account, whether dedicated or shared.

4.1.4.2 Scale

KPI_{REN} applies to all data centres of all sizes and includes IT rooms located in buildings.

4.1.4.3 Evolution

KPI_{REN} applies to all states of data centres, from initial operation to end of life.

4.1.4.4 Formula

$$KPI_{REUSE} = \frac{EC_{REN}}{EC_{DC}}$$

where:

EC_{DC} = Total of energy consumptions by a data centre over a year.
 EC_{REN} = Measurement of reused energy.

4.1.4.5 Measurement Points and processes

According to methodology defined in clause 4.1.1.6.

The quantity of energy coming from renewable sources is the total of energy coming from such sources, used by the data centre, minus the traditional energy required to produce or deliver this energy to the consumption point.

All the measurement shall be done over the same evaluation period.

This KPI shall be considered only if the amount of conventional energy required to produce it is no greater than 10 % of the produced renewable energy.

4.2 Global KPI (KPI_{DCEM}) using the Objective KPIs

4.2.1 Introduction

The set of Objective KPIs defined in the 4.1 are used to define a Global KPI (KPI_{DCEM}) that allows benchmarking the energy efficiency of data centres depending on their gauge.

KPI_{DCEM} is composed of two values, DC_G and DC_P , where:

- DC_G defines the energy consumption gauge of the DC;
- DC_P defines the performance of the DC for the relevant gauge.

The default number of DC_G gauges is 4 as shown in table 1 can be adapted by the user of the KPI_{DCEM} .

Table 1: Default Gauges (DC_G)

DC_G	KPI_{EC} range
S	$KPI_{EC} \leq 1$ GWh
M	$1 \text{ GWh} < KPI_{EC} \leq 4$ GWh
L	$4 \text{ GWh} < KPI_{EC} \leq 20$ GWh
XL	$KPI_{EC} > 20$ GWh

The calculation of DC_P is addressed in clause 4.2.4. Default classes are as shown in table 2.

Table 2: Default Classes of DC_P

DC commissioning date	since 2005 (see note)		before 2005 (see note)	
	DC_P		DC_P	
Class	\geq	$<$	\geq	$<$
A		0,70		1,00
B	0,70	1,00	1,00	1,40
C	1,00	1,30	1,40	1,70
D	1,30	1,50	1,70	1,90
E	1,50	1,70	1,90	2,10
F	1,70	1,90	2,10	2,30
G	1,90	2,10	2,30	2,50
H	2,10	2,40	2,50	2,70
I	2,40		2,70	

NOTE: Year of Kyoto Protocol entering into force.

The Global KPI_{GP} is presented as a combination of the two values, DC_G and DC_P , in the following form: Gauge (see table 1), Class (see table 2) e.g. M, E.

4.2.2 Scale

KPI_{DCEM} applies to all data centres of all sizes and includes IT rooms located in buildings.

4.2.3 Evolution

KPI_{DCEM} applies to all states of data centres, from initial operation to end of life.

4.2.4 Formula for DC_P

The following formula applies to the calculation of DC_P for all the gauges:

$$DC_P = KPI_{TE} \times (1 - W_{REUSE} \times KPI_{REUSE}) \times (1 - W_{REN} \times KPI_{REN})$$

where:

- W_{REUSE} = Mitigation factor for KPI_{REUSE} (the value may vary depending on the gauge (ffs) within the range 0 to 1, the default value is 0,5).
- W_{REN} = Mitigation factor for KPI_{REN} (the value may vary depending on the gauge (ffs) within the range 0 to 1, the default value is 0,5).

4.2.5 Measurement points and processes

According to methodology defined in clause 4.1.

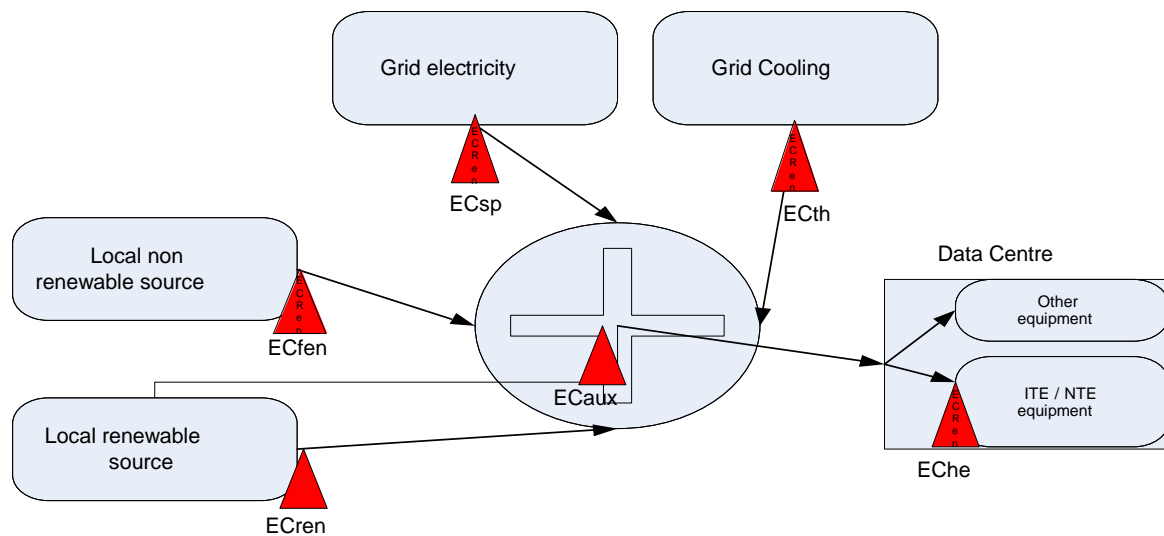

Figure 1: Energy measurement points

Annex A (informative): Energy Consumption per square metre (KPI_{EC1})

A.1 Generalities

KPI_{EC1} is calculated from KPI_{EC} and takes into account the IT room floor space.

A.2 Scale

KPI_{EC1} applies to all data centres of all sizes and includes IT rooms located in buildings.

A.3 Evolution

KPI_{EC1} applies to all states of data centres, from initial operation to end of life.

A.4 Formula

$$KPI_{EC1} = \left(\frac{KPI_{EC}}{(1 + W_{CRs}) \times (CRs - 1)} \right)$$

where:

- CRs = IT room floor space used (by racks, networking, disk arrays and tape robots) = raw footprint of IT and Telco equipment).
 W_{CRs} = CRs mitigation ratio; ranges from 0 to 1.

A.5 Measurement points and procedures

See clause 4.1.1.4.

Annex B (informative): The status of Key Performance Indicators (KPIs)

B.1 Technical KPIs

At the most basic level, individual components or sub-assemblies can be designed to have improved task efficiency i.e. less energy is consumed for a given output or task. Such components or sub-assemblies may be inherently more efficient in the way in which they use energy under specific operating conditions but are essentially unable to manage that consumption. An example of such a product would be a power supply unit which may be more efficient under higher load conditions.

More complex products may contain hardware and/or software which automatically reduces energy consumption under specific operating conditions by putting certain functions into "idle" states if not required. This is distinctly different than that of a single task component or sub-assembly detailed above.

Technical KPIs can be applied to both of the above by assessing energy consumption for a number of specific operating conditions and also across a combination of such operating conditions. Assuming those operating conditions reflect the probable operating environment for the component, sub-assembly or product, a customer may make valued judgements in relation to the appropriateness of the Technical KPI.

For example, two products that have equal "combined" Technical KPIs, may be more efficient under very specific conditions. For example, a design of power supply that is more task efficient under high load conditions may be inappropriate for users who plan to predominantly operate under low load conditions (and vice versa).

A higher level of task efficiency management is also possible where groups of products are managed to reduce energy consumption by either allocating loads in such a way that the group is operating at maximum task efficiency and/or by putting individual products within the group into an "idle" mode. Examples of such managed solutions are seen in data centre software plug-ins (such as those developed under the Fit4Green and GAMES projects funded by the European Commission) and in documents developed by ETSI TC EE. Once again, the value of such approaches can be validated by the establishment of Technical KPIs which can be applied to both of the above by assessing energy consumption of a defined group of products for a number of specific operating conditions and also across a combination of such operating conditions.

Figure B.1 provides a schematic in relation to energy-related KPIs. The left-hand side of that schematic relates to the Technical KPIs of the design and engineering phase for components, sub-assemblies, products and systems.

B.2 Objective KPIs

The Objective KPIs described in the documents of the ES 205 200 series [i.9] relate to specific elements of energy management described in clause B.1 for operational infrastructures under the control of operators as follows:

- energy consumption: the total consumption of energy by an operational infrastructure;
- task efficiency: a measure of the work done (as a result of design and/or operational procedures) for a given amount of energy consumed;
- energy re-use: transfer or conversion of energy (typically in the form of heat) produced by the operational infrastructure to do other work;
- renewable energy: energy produced from dedicated generation systems using resources that are naturally replenished.

The procurement of products and systems based upon their Technical KPIs for energy consumption and/or task efficiency underpins the relevant Objective KPIs. However, the ES 205 200 series documents [i.9] define requirements for the measurement of those Objective KPIs for operational infrastructures i.e. taking into account the real operating conditions over a defined period of time.

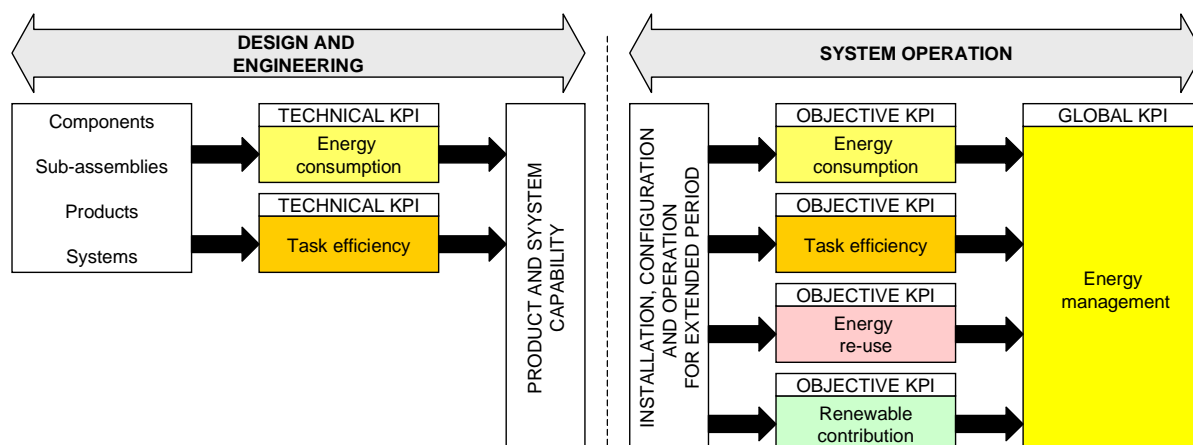

Figure B.1: The relationship of energy-related Technical, Objective and Global KPIs

The performance of products and systems, of proven Technical KPIs performance, may exhibit different energy consumption and task efficiency characteristics when subjected to actual operating conditions which lie outside those of the Technical KPIs applied to those products and systems at the design and engineering stages and, equally importantly, when subjected to user configuration and controls which may undermine the sophisticated systems available.

The right-hand side of the schematic in figure B.1 relates to the Objective KPIs of complete infrastructures in the operational phase.

B.3 Global KPIs

The Objective KPIs, of which task efficiency is only one, are combined using a formula appropriate to the specific operational infrastructure to produce a Global operational KPI which reflects the overall performance of the operational infrastructures against wider energy management targets which may be self-imposed by the operators or externally applied by legislators.

Global KPIs provide a wider view of a users commitment to strategic energy management practices than the Objective KPIs. For example a user is not supporting overall energy goals by achieving class-leading provision of local renewable energy if their overall energy consumption is based upon equipment with very poor task efficiency.

B.4 Summary

Operational Global and Objective KPIs are fundamentally different to the Technical KPIs applied to products and systems at the design and engineering stages. The former are used to monitor and drive user behaviour whereas the latter are substantial indications of potential operational performance.

It is therefore important to support, but differentiate, the role of the Technical KPIs from the Objective and Global operational KPIs.

History

Document history		
V1.1.1	January 2013	Publication
V1.2.1	April 2013	Publication