



HARMONISED EUROPEAN STANDARD

**Short Range Devices (SRD);
Inductive loop systems for robotic mowers
in the frequency range 0 Hz to 148,5 kHz;
Harmonised Standard covering the essential requirements
of article 3.2 of Directive 2014/53/EU**

Reference

DEN/ERM-TG28-541

Keywords

harmonised standard, inductive, measurement,
radio

ETSI

650 Route des Lucioles
F-06921 Sophia Antipolis Cedex - FRANCE

Tel.: +33 4 92 94 42 00 Fax: +33 4 93 65 47 16

Siret N° 348 623 562 00017 - NAF 742 C
Association à but non lucratif enregistrée à la
Sous-Préfecture de Grasse (06) N° 7803/88

Important notice

The present document can be downloaded from:

<http://www.etsi.org/standards-search>

The present document may be made available in electronic versions and/or in print. The content of any electronic and/or print versions of the present document shall not be modified without the prior written authorization of ETSI. In case of any existing or perceived difference in contents between such versions and/or in print, the only prevailing document is the print of the Portable Document Format (PDF) version kept on a specific network drive within ETSI Secretariat.

Users of the present document should be aware that the document may be subject to revision or change of status. Information on the current status of this and other ETSI documents is available at

<https://portal.etsi.org/TB/ETSIDeliverableStatus.aspx>

If you find errors in the present document, please send your comment to one of the following services:

<https://portal.etsi.org/People/CommiteeSupportStaff.aspx>

Copyright Notification

No part may be reproduced or utilized in any form or by any means, electronic or mechanical, including photocopying and microfilm except as authorized by written permission of ETSI.

The content of the PDF version shall not be modified without the written authorization of ETSI.

The copyright and the foregoing restriction extend to reproduction in all media.

© ETSI 2017.
All rights reserved.

DECT™, **PLUGTESTS™**, **UMTS™** and the ETSI logo are Trade Marks of ETSI registered for the benefit of its Members.
3GPP™ and **LTE™** are Trade Marks of ETSI registered for the benefit of its Members and of the 3GPP Organizational Partners.

oneM2M logo is protected for the benefit of its Members
GSM® and the GSM logo are Trade Marks registered and owned by the GSM Association.

Contents

Intellectual Property Rights	5
Foreword.....	5
Modal verbs terminology.....	5
Introduction	5
1 Scope	7
2 References	7
2.1 Normative references	7
2.2 Informative references.....	7
3 Definitions, symbols and abbreviations	8
3.1 Definitions	8
3.2 Symbols.....	9
3.3 Abbreviations	10
4 Technical requirements specifications	10
4.1 Environmental conditions.....	10
4.2 General	10
4.2.1 Wanted performance criteria.....	10
4.2.2 RMI functional mode.....	10
4.2.2.1 General	10
4.2.2.2 Operational Mode	11
4.2.2.3 Safe Mode	11
4.2.3 Presentation of equipment for testing purposes	11
4.3 Transmitter conformance requirements.....	11
4.3.1 Operating Frequency Range (OFR).....	11
4.3.1.1 Applicability.....	11
4.3.1.2 Description	11
4.3.1.3 Limits	12
4.3.1.4 Conformance	12
4.3.2 Transmitter H-field requirements	12
4.3.2.1 Applicability.....	12
4.3.2.2 Description	12
4.3.2.3 Limits	13
4.3.2.4 Conformance	13
4.3.3 Transmitter spurious emissions.....	13
4.3.3.1 Applicability.....	13
4.3.3.2 Description	13
4.3.3.3 Limits	14
4.3.3.4 Conformance	15
4.3.4 Transmitter out of band (OOB) emissions	15
4.3.4.1 Applicability.....	15
4.3.4.2 Description	15
4.3.4.3 Limits	15
4.3.4.4 Conformance	15
4.4 Receiver Conformance requirements	15
4.4.1 Introduction.....	15
4.4.2 Receiver unwanted emissions	16
4.4.3 Receiver blocking	16
4.4.3.1 Applicability.....	16
4.4.3.2 Description	16
4.4.3.3 Limits	16
4.4.3.4 Conformance	16
5 Testing for compliance with technical requirements.....	17
5.1 Environmental conditions for testing	17
5.2 General conditions for testing	17

5.2.1	Product information	17
5.3	Normal and extreme test conditions	17
5.4	Artificial antenna	17
5.5	Test sites and general arrangements for radiated measurements	17
5.6	Measuring receiver	18
5.7	Measurement uncertainty	18
5.8	Interpretation of the measurement results	18
6	Conformance methods of measurement for transmitters and receivers	18
6.1	General	18
6.2	Transmitter conformance methods	19
6.2.1	OFR	19
6.2.2	H-field	19
6.2.3	Transmitter unwanted emissions (spurious and OOB emissions)	20
6.3	Receiver conformance methods	20
6.3.1	Receiver spurious emissions	20
6.3.2	Receiver blocking	20
Annex A (informative):	Relationship between the present document and the essential requirements of Directive 2014/53/EU	24
Annex B (normative):	Test sites and procedures	25
B.1	Set-up 1: Magnetic field measurements at a Test Garden	25
B.2	Set-up 2: Carrier current measurements using an artificial antenna	25
B.2.1	General	25
B.2.2	Differential mode measurement	26
B.2.3	Common mode measurement	26
B.3	Radiated measurements using anechoic chamber or open area test site	26
Annex C (normative):	Artificial antenna for conducted measurements below 30 MHz	27
Annex D (informative):	Change history	30
History		31

Intellectual Property Rights

IPRs essential or potentially essential to the present document may have been declared to ETSI. The information pertaining to these essential IPRs, if any, is publicly available for **ETSI members and non-members**, and can be found in ETSI SR 000 314: "*Intellectual Property Rights (IPRs); Essential, or potentially Essential, IPRs notified to ETSI in respect of ETSI standards*", which is available from the ETSI Secretariat. Latest updates are available on the ETSI Web server (<https://ipr.etsi.org>).

Pursuant to the ETSI IPR Policy, no investigation, including IPR searches, has been carried out by ETSI. No guarantee can be given as to the existence of other IPRs not referenced in ETSI SR 000 314 (or the updates on the ETSI Web server) which are, or may be, or may become, essential to the present document.

Foreword

This final draft Harmonised European Standard (EN) has been produced by ETSI Technical Committee Electromagnetic compatibility and Radio spectrum Matters (ERM), and is now submitted for the Vote phase of the ETSI standards EN Approval Procedure.

The present document has been prepared under the Commission's standardisation request C(2015) 5376 final [i.6] to provide one voluntary means of conforming to the essential requirements of Directive 2014/53/EU on the harmonisation of the laws of the Member States relating to the making available on the market of radio equipment and repealing Directive 1999/5/EC [i.3].

Once the present document is cited in the Official Journal of the European Union under that Directive, compliance with the normative clauses of the present document given in table A.1 confers, within the limits of the scope of the present document, a presumption of conformity with the corresponding essential requirements of that Directive, and associated EFTA regulations.

Proposed national transposition dates	
Date of latest announcement of this EN (doa):	3 months after ETSI publication
Date of latest publication of new National Standard or endorsement of this EN (dop/e):	6 months after doa
Date of withdrawal of any conflicting National Standard (dow):	18 months after doa

Modal verbs terminology

In the present document "**shall**", "**shall not**", "**should**", "**should not**", "**may**", "**need not**", "**will**", "**will not**", "**can**" and "**cannot**" are to be interpreted as described in clause 3.2 of the [ETSI Drafting Rules](#) (Verbal forms for the expression of provisions).

"**must**" and "**must not**" are **NOT** allowed in ETSI deliverables except when used in direct citation.

Introduction

The present document covers Robotic Mowers with Inductive loop systems (RMI) using the frequency range below 148,5 kHz. An RMI system includes:

- RMI docking station: charging stations for the robotic mower and the signal generator/antenna connecting point for the signals on the integral antenna and boundary wire.
- Robotic Mower: receiving part inside the RMI.
- Boundary Wire: user installed antenna.

The present document is structured as follows:

Clauses 1 through 3 provide a general description on the types of equipment covered by the present document and the definitions, symbols and abbreviations used.

Clause 4 provides the technical requirements specifications, limits and conformance relative to transmitter and receiver.

Clause 5 specifies the conditions for testing of the equipment and interpretation of the measurement results with the maximum measurement uncertainty values.

Clause 6 specifies the required measurement methods.

Annex A (informative) provides the relationship between the present document and the essential requirements of Directive 2014/53/EU [i.3].

Annex B (normative) provides necessary information on used test sites and procedures.

1 Scope

The present document specifies technical characteristics and methods of measurements for Robotic Mowers with Inductive loop systems (RMI) below 148,5 kHz.

These radio equipment types are capable of operating in all or part of the frequency bands given in table 1.

Table 1: Permitted range of operation

Permitted range of operation	
Transmit	0 Hz to 148,5 kHz
Receive	0 Hz to 148,5 kHz
NOTE:	It should be noted that the frequency range between 9 kHz and 148,5 kHz is EU wide harmonised for inductive Short Range Devices according to EC Decision 2013/752/EU [i.2].

The present document does not cover other devices using the frequency range below 148,5 kHz, e.g. ETSI EN 303 348 [i.9] (Inductive loop for hearing impaired in 0 kHz to 20 kHz), ETSI EN 303 454 [i.10] (metal sensors).

The present document covers the essential requirements of article 3.2 of Directive 2014/53/EU [i.3] under the conditions identified in annex A.

2 References

2.1 Normative references

References are specific, identified by date of publication and/or edition number or version number. Only the cited version applies.

Referenced documents which are not found to be publicly available in the expected location might be found at <https://docbox.etsi.org/Reference/>.

NOTE: While any hyperlinks included in this clause were valid at the time of publication, ETSI cannot guarantee their long term validity.

The following referenced documents are necessary for the application of the present document.

- [1] ETSI EN 300 330 (V2.1.1) (02-2017): "Short Range Devices (SRD); Radio equipment in the frequency range 9 kHz to 25 MHz and inductive loop systems in the frequency range 9 kHz to 30 MHz; Harmonised Standard covering the essential requirements of article 3.2 of Directive 2014/53/EU".

2.2 Informative references

References are either specific (identified by date of publication and/or edition number or version number) or non-specific. For specific references, only the cited version applies. For non-specific references, the latest version of the referenced document (including any amendments) applies.

NOTE: While any hyperlinks included in this clause were valid at the time of publication, ETSI cannot guarantee their long term validity.

The following referenced documents are not necessary for the application of the present document but they assist the user with regard to a particular subject area.

- [i.1] CEPT/ERC/REC 70-03: "Relating to the use of Short Range Devices (SRD)".
- [i.2] EC Decision 2013/752/EU: "Commission implementing Decision of 11 December 2013 amending Decision 2006/771/EC on harmonisation of the radio spectrum for use by short-range devices and repealing Decision 2005/928/EC".

- [i.3] Directive 2014/53/EU of the European Parliament and of the Council of 16 April 2014 on the harmonisation of the laws of the Member States relating to the making available on the market of radio equipment and repealing Directive 1999/5/EC.
- [i.4] CEPT/ERC/REC 74-01: "Unwanted emissions in the spurious domain".
- [i.5] ETSI EG 203 336: "Electromagnetic compatibility and Radio spectrum Matters (ERM); Guide for the selection of technical parameters for the production of Harmonised Standards covering article 3.1(b) and article 3.2 of Directive 2014/53/EU".
- [i.6] Commission Implementing Decision C(2015) 5376 final of 4.8.2015 on a standardisation request to the European Committee for Electrotechnical Standardisation and to the European Telecommunications Standards Institute as regards radio equipment in support of Directive 2014/53/EU of the European Parliament and of the Council.
- [i.7] EGMF Robotic Mowers Boundary Wire Standard RLM003-1.0/2014.
- [i.8] CENELEC EN 50636-2-107:2015: "Safety of household and similar appliances - Part 2-107: Particular requirements for robotic battery powered electrical lawnmowers".
- [i.9] ETSI EN 303 348: "Induction loop systems intended to assist the hearing impaired in the frequency range 10 Hz to 9 kHz; Harmonised Standard covering the essential requirements of article 3.2 of Directive 2014/53/EU".
- [i.10] ETSI EN 303 454: "Short Range Devices (SRD); Metal and object detection sensors in the frequency range 1 kHz to 148,5 kHz; Harmonised Standard covering the essential requirements of article 3.2 of Directive 2014/53/EU".
- [i.11] Directive 2006/42/EC of the European Parliament and of the Council of 17 May 2006 on machinery, and amending Directive 95/16/EC (recast).

3 Definitions, symbols and abbreviations

3.1 Definitions

For the purposes of the present document, the terms and definitions given in ETSI EN 300 330 [1] and the following apply:

antenna: factory defined loop(s) (e.g. integral antenna) and/or user defined loop(s) (e.g. boundary wire, guidance wire), which are used for the functional mode of the RMI

NOTE: The inductive wire loops are installed dependent from the shape of the garden. A current is fed into these inductive loops to generate a magnetic field intended for guidance and/or communication with the robotic mower.

boundary wire: inductive wire loop which will be defined/prepared by the user

NOTE: It can be implemented as a single or multiple turn coil installed by the user in accordance with instruction from the manufacturer for the purpose of generating magnetic fields to determine the working area.

factory defined loop: either integral antenna or inductive wire loop that may reach outside the docking station and needs to be completed by the user according to manufacturer specifications in size and shape

guidance wire: electrical wire which is defined by manufacturer and prepared by the user

integral antenna: single or multiple turn coil preinstalled inside the RMI docking station for the purpose of generating magnetic fields such as for guidance and or communication with the robotic mower

Occupied bandwidth (OBW): width of a frequency band such that, below the lower and above the upper frequency limits, the mean powers emitted are each equal to 0,5 % of the total mean power of a given emission

NOTE: To clarify occupied bandwidth (OBW), see figure 1.

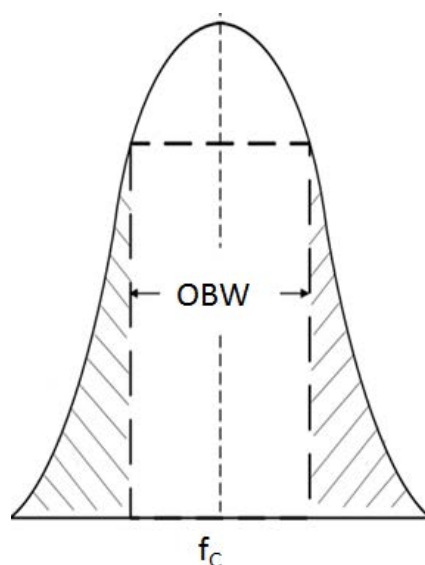

Figure 1: Occupied bandwidth (OBW)

99 % OBW function: measurement function of a spectrum analyser

RMI docking station: charging stations for the robotic mower and the signal generator for the signals on the integral antenna and boundary wire

NOTE: The RMI docking station can be seen as the signal generator/antenna connecting point. In addition it is the automatic battery charging facility located on or within the working area.

robotic mower: mobile part of the RMI including cutting means. It is the receiving part inside the RMI

Robotic Mower with Inductive loop system (RMI): system that include robotic mower, boundary wire, docking station with integral antenna, guiding wires, power supply

user defined loop: single or multiple turn coil installed by the user in accordance with instruction from the manufacturer for the purpose of generating magnetic fields such as for guidance and/or communication with the robotic mower and/or to determine the working area

3.2 Symbols

For the purposes of the present document, the symbols given in ETSI EN 300 330 [1] and the following apply:

C_A	filtering capacitors of the artificial antenna
f_c	centre frequency of the OFR
f_H	highest frequency of the OFR
f_L	lowest frequency of the OFR
f_{SH}	higher frequency border between OOB and spurious domain
f_{SL}	lower frequency border between OOB and spurious domain
I_{CM}	Common mode current
I_{DM}	Differential mode current
L_A	inductive part of the artificial antenna
R_A	low frequency resistive part of the artificial antenna
R_C	common mode resistive part of the artificial antenna
R_D	high frequency resistive part of the artificial antenna

3.3 Abbreviations

For the purposes of the present document, the abbreviations given in ETSI EN 300 330 [1] and the following apply:

CM	Common Mode
DM	Differential Mode
EGMF	European Garden Machinery industry Federation
OBW	Operating BandWidth
OFR	Operating Frequency Range
OOB	Out Of Band
RMI	Robotic Mower with Inductive loop system

4 Technical requirements specifications

4.1 Environmental conditions

The technical requirements of the present document apply under the environmental profile for operation of the equipment, which shall be declared by the manufacturer. The equipment shall comply with all the technical requirements of the present document which are identified as applicable in annex A at all times when operating within the boundary limits of the declared operational environmental profile. The conditions shall be used as described in clause 5.3.

4.2 General

4.2.1 Wanted performance criteria

For the purpose of the receiver performance tests, the RMI shall produce an appropriate output under normal conditions as indicated below:

- use as intended without degradation of performance; or
- a degradation of the performance is indicated by the RMI as described in the manual.

The manufacturer shall declare the performance criteria used.

A robotic mower inside an RMI will only work if:

- there will be a signal on the boundary wire; and
- this signal is received by the robotic mower.

If there is no reception of the boundary signal by the robotic mower, then the robotic mower has to switch into the safe mode (see clause 4.2.2.3). The robotic mower has to switch into this safe mode also if it is not able to receive the boundary signal based on the presence of other signals/interferer.

When the robotic mower is operating, the robotic mower shall not be able to leave the working area, see clause 4.2.2.2.

4.2.2 RMI functional mode

4.2.2.1 General

In this clause all general considerations for the testing of the inductive parts for the RMI in the frequency range from 0 Hz to 148,5 Hz are given.

Typical functional modes being part of an RMI are explained in the following clauses.

An RMI can have different user defined loops and factory defined loops. The requirements tests shall be performed for each loop separately.

If additional mode/antenna/user defined loops are implemented by the manufacturer, then this mode shall be declared for the preparation of the tests.

The test set-up of the different modes shall be performed as described in clause 6.1 and annex B.

4.2.2.2 Operational Mode

Operational mode is the working mode of the RMI. During this mode the robotic mower is cutting the grass inside the working area and it shall not be possible for the robotic mower to cross the boundary by a distance of more than one full length of the robotic mower, see CENELEC EN 50636-2-107 [i.8], clause 22.104.2.

The generated signal will be transmitted on the declared user defined loops and factory defined loops. The manufacturer shall declare the active antennas for this mode.

If the RMI has an additional mode (other combination of active antennas) the manufacturer shall declare this additional mode and the test shall be performed according to this operational mode.

4.2.2.3 Safe Mode

Safe mode: after a loss of signal, the RMI shall not travel more than 1 m and the cutting means shall stop within 5 s, see CENELEC EN 50636-2-107 [i.8], clause 22.104.2. It is not possible to start the robotic mower in automatic mode.

4.2.3 Presentation of equipment for testing purposes

Each RMI submitted for testing shall fulfil the requirements of the present document.

The manufacturer shall declare the range of operating conditions and power requirements as applicable, to establish the appropriate test conditions.

Additionally, technical documentation and operating manuals, sufficient to make the test, shall be supplied.

If an RMI system is designed to operate with different operational modes (see clause 4.2.2.2), measurement of each mode shall be performed, according to the present document on samples of equipment defined in clause 4.2.2 of ETSI EN 300 330 [1].

To simplify and harmonise the testing procedures between different testing laboratories, measurements shall be performed, according to the present document, on samples defined in clause 4.2.2 of ETSI EN 300 330 [1].

4.3 Transmitter conformance requirements

4.3.1 Operating Frequency Range (OFR)

4.3.1.1 Applicability

This requirement applies to all RMI.

4.3.1.2 Description

The operating frequency range is the frequency range over which the RMI is intentionally transmitting. The operating frequency range of the RMI is determined by the lowest (f_L) and highest frequency (f_H).

An RMI can have more than one operating frequency range (relating to the operational modes and antennas of the RMI system, see clause 4.2.2).

For a single frequency system the OFR is equal to the occupied bandwidth (OBW) of the RMI system as described in figure 2.

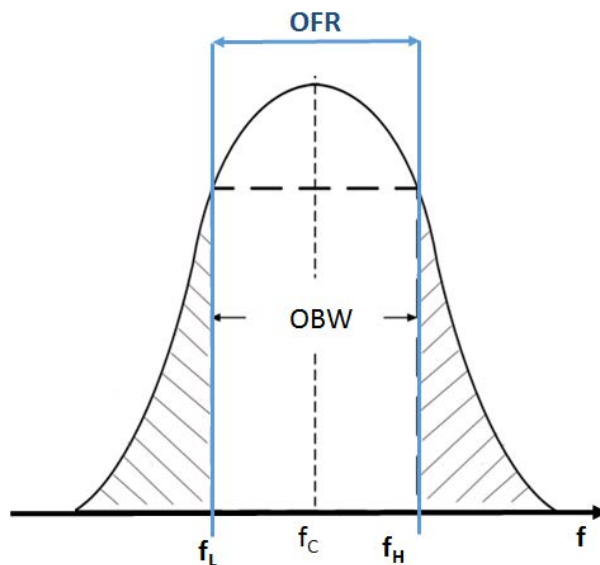

Figure 2: Operating Frequency Range (OFR)

4.3.1.3 Limits

The operating frequency range for intentional emissions shall be within the following limits:

- Upper edge of the operating frequency range: $f_H \leq 148,5 \text{ kHz}$.
- Lower edge of the operating frequency range: $f_L \geq 0 \text{ Hz}$.

For the later spurious and OOB emission measurement procedures in clauses 4.3.3 and 4.3.4 the OFR shall be calculated as: $f_H - f_L$ and the centre frequency as: $f_c = \frac{f_H + f_L}{2}$.

NOTE: If the result for f_L is lower than 500 Hz the value of $f_L = 500 \text{ Hz}$ is appropriate in the calculation of f_C and OFR. This limit of $f_L = 500 \text{ Hz}$ is based on available test equipment in order to achieve reliable test results (measurement uncertainty).

4.3.1.4 Conformance

The conformance test suite for operational frequency range shall be as defined in clause 6.1 (table 8).

Conformance shall be established under test conditions to be declared by the manufacturer according to clause 4.1.

The interpretation of the results for the measurements uncertainty shall be as given in clause 5.7.

4.3.2 Transmitter H-field requirements

4.3.2.1 Applicability

This requirement applies to all RMI.

4.3.2.2 Description

The radiated H-field is defined in the direction of maximum field strength of the RMI.

4.3.2.3 Limits

The H-field limits for the band below 9 kHz are provided in table 2 and for the band 9 kHz to 148,5 kHz in table 3.

For the frequency range below 9 kHz no frequency usage conditions were known and available at the time of preparation of the present document. However, the H-field limits in table 2 are suggested to improve the intra-RMI coexistence.

Table 2: H-field limits below 9 kHz

Frequency range (kHz)	H-field strength limit (H_f) dB μ A/m at 10 m
$0,3 \leq f < 0,9$	82
$0,9 \leq f < 9$	82 descending 10 dB/dec

Table 3: H-field limits between 9 kHz and 148,5 kHz [i.2]

Frequency range (MHz)	H-field strength limit (H_f) dB μ A/m at 10 m
$0,009 \leq f < 0,060$	72 descending 10 dB/dec above 0,03 MHz
$0,060 \leq f < 0,090$	42
$0,09 \leq f < 0,119$	42
$0,119 \leq f < 0,135$	42
$0,135 \leq f < 0,140$	42
$0,140 \leq f < 0,1485$	37,7
NOTE: The H-field limits in this table are complying with the limits for "inductive SRD devices" in EC Decision 2013/752/EU [i.2]. Further information is available in CEPT/ERC/REC 70-03 [i.1].	

4.3.2.4 Conformance

The conformance test suite for transmitter H-field requirements shall be as defined in clause 6.1 (table 8).

Conformance shall be established under test conditions to be declared by the manufacturer according to clause 4.1.

The interpretation of the results for the measurements uncertainty shall be as given in clause 5.7.

4.3.3 Transmitter spurious emissions

4.3.3.1 Applicability

This requirement applies to all RMI.

4.3.3.2 Description

The transmitter spurious emissions for a single frequency system are to be considered in frequency ranges defined in figure 3 ($f < f_{SL}$ and $f > f_{SH}$).

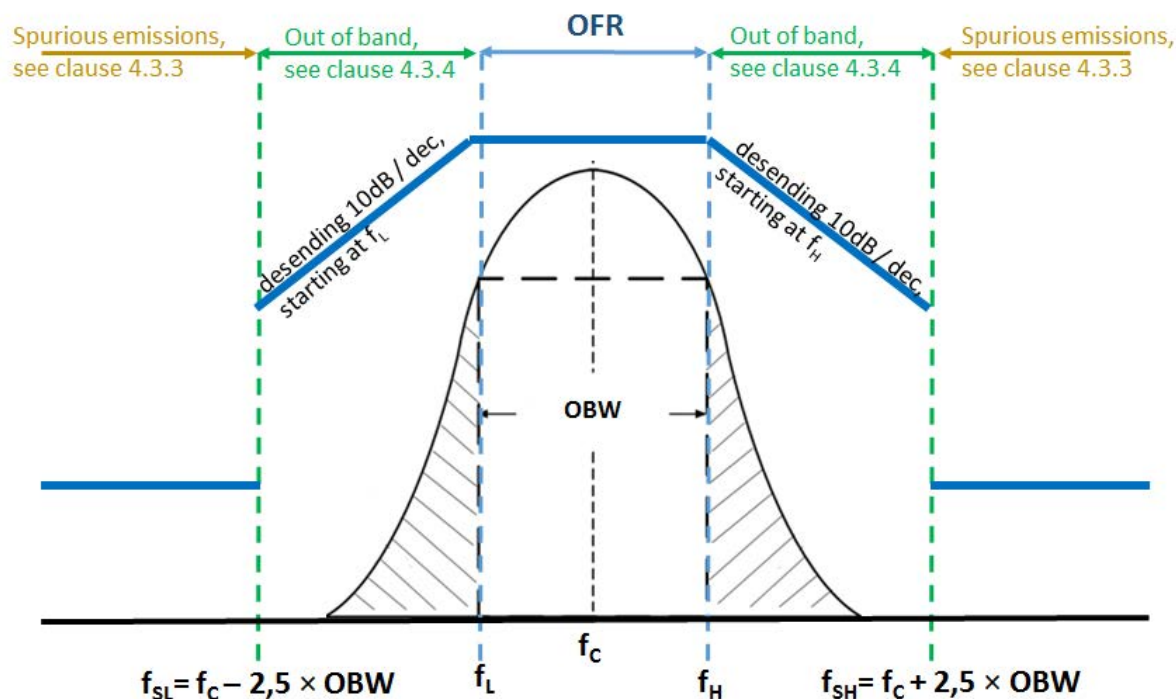

Figure 3: Out of band and spurious domain of a single frequency system

The following additional conditions applying for f_{SH} :

- 1) For systems with $f_H \leq 9$ kHz: f_{SH} shall be set to 27 kHz.
- 2) For systems with $f_H > 9$ kHz: f_{SH} is the smallest of:
 - $f = f_C + 2,5 \times OFR$;
 - or
 - $f = 148,5$ kHz.

NOTE 1: f_{SH} under number 1 above was calculated based on an assumed f_C of 4,5 kHz and OBW of 9 kHz.

NOTE 2: Bullet two of number 2) above ensures that the spurious limits of CEPT/ERC/REC 74-01 [i.4] applies above 148,5 kHz.

4.3.3.3 Limits

The spurious emissions shall not exceed the limits given in table 4 and table 5.

Table 4: Magnetic field limits of CEPT/ERC/REC 74-01 [i.4] at 10 m distance

State	Frequency $9 \text{ kHz} \leq f < 10 \text{ MHz}$	Frequency $10 \text{ MHz} \leq f < 30 \text{ MHz}$
Operating	27 dB μ A/m at 9 kHz descending 3 dB/oct	-3,5 dB μ A/m
Standby	5,5 dB μ A/m at 9 kHz descending 3 dB/oct	-25 dB μ A/m
NOTE: There are no spurious emission limits < 9 kHz.		

The power of any conducted spurious emission (at the antenna port) shall not exceed the values given in table 5.

**Table 5: Spurious emission limits of CEPT/ERC/REC 74-01 [i.4]
between 30 and 1 000 MHz**

State	47 MHz to 74 MHz 87,5 MHz to 118 MHz 174 MHz to 230 MHz 470 MHz to 790 MHz	Other Frequencies between 30 MHz to 1 000 MHz
Operating	4 nW	250 nW
Standby	2 nW	2 nW

4.3.3.4 Conformance

The conformance test suite for transmitter spurious emissions shall be as defined in clause 6.1 (table 8).

Conformance shall be established under test conditions to be declared by the manufacturer according to clause 4.1.

The interpretation of the results for the measurements uncertainty shall be as given in clause 5.7.

4.3.4 Transmitter out of band (OOB) emissions

4.3.4.1 Applicability

This requirement applies to all RMI

4.3.4.2 Description

The transmitter out of band emissions are to be considered in frequency ranges defined in figure 3 (between f_{SL} and f_L and between f_H and f_{SH}).

4.3.4.3 Limits

The OOB limits are visualized in figure 3; they are descending from the intentional limits from table 2 and table 3 at f_H/f_L with 10 dB/decade.

NOTE: There are no OOB limits < 9 kHz.

4.3.4.4 Conformance

The conformance test suite for Transmitter out of band emissions is provided in clause 6.1 (table 8).

Conformance shall be established under test conditions to be declared by the manufacturer according to clause 4.1.

The interpretation of the results for the measurements uncertainty shall be as given in clause 5.7.

4.4 Receiver Conformance requirements

4.4.1 Introduction

ETSI EG 203 336 [i.5] lists candidate technical parameters to be included in a Harmonised Standard aimed at providing a presumption of conformity of radio equipment with the essential requirements in articles 3.1(b) and 3.2 of the Radio Equipment Directive 2014/53/EU [i.3].

Essential requirements are high level objectives described in European Directives. The purpose of the present document is to translate those high level objectives into detailed technical specifications.

4.4.2 Receiver unwanted emissions

The robotic mower is the only part of the RMI which is receiving.

But the mowers cannot be used without any boundary signal, see listed harmonised standard CENELEC EN 50636-2-107 [i.8] under the European Machinery Directive 2006/42/EC [i.11].

During normal operation the robotic mower is co-located within the boundary wire/loop and therefore it is not possible to differentiate between the unwanted emissions from the transmitter and from the RX part of the robotic mower. Therefore, this test is not applicable.

4.4.3 Receiver blocking

4.4.3.1 Applicability

This requirement applies to all RMI.

4.4.3.2 Description

Blocking is a measure of the capability of the receiver to receive a wanted modulated signal without exceeding a given degradation due to the presence of an unwanted input signal at any frequencies other than those of the receiver spurious responses.

The test shall be in the typical operational mode (real scenario, see clause 4.2.2.2).

The wanted performance criteria (clause 4.2.1) will be used for the receiver blocking tests.

4.4.3.3 Limits

The receiver blocking limits in table 6 shall be fulfilled.

Table 6: Receiver blocking limits

	In-band signal	OOB signal	Remote-band signal
Frequency	$f = f_c$	$f = f_c \pm \text{OFR}$	$f = f_c \pm 10 \times \text{OFR}$
receiver blocking limits	98 dB μ A/m - 20log10 (f/10 kHz)	98 dB μ A/m - 20log10 (f/10 kHz)	98 dB μ A/m - 20log10 (f/10 kHz)
NOTE:	Background for limits in table 6: The industry standard for RMI (Source: EGMF [i.7]) proposes that robotic mower installations should never be closer than 1 meter and the RMS current in the wire should never exceed 500 mA. When an interfering standard garden is located at a distance of 1 m with long side to long side the H field from a 500 mA current will be 98 dB μ A/m (or 100 nT for B-field). Robotic mowers use coils as antennas and the electromagnetic force (EMF) generated in those antennas are proportional to the derivative of the signals. Therefore, when doubling the frequency of the interfering signal the voltage generated in the antenna will also double. The 100 nT is therefore normalized to a typical robotic mower signal centre frequency of 10 kHz.		

The RMI shall achieve the wanted performance criteria, see clause 4.2.1, in the presence of the blocking signal.

4.4.3.4 Conformance

The conformance test suite for operational frequency range shall be as defined in clause 6.1 (table 8).

Conformance shall be established under test conditions to be declared by the manufacturer according to clause 4.1.

The interpretation of the results for the measurements uncertainty shall be as given in clause 5.7.

5 Testing for compliance with technical requirements

5.1 Environmental conditions for testing

Tests defined in the present document shall be carried out at representative points within the boundary limits of the declared operational environmental profile.

Where technical performance varies subject to environmental conditions, tests shall be carried out under a sufficient variety of environmental conditions (within the boundary limits of the declared operational environmental profile) to give confidence of compliance for the affected technical requirements.

5.2 General conditions for testing

5.2.1 Product information

The provisions of ETSI EN 300 330 [1], clause 5.2.1 shall apply except as varied herein.

All necessary test signal sources and set-up information shall accompany the equipment when it is submitted for testing.

5.3 Normal and extreme test conditions

The provisions of ETSI EN 300 330 [1], clause 5.3 shall apply.

5.4 Artificial antenna

Tests using the artificial antenna are specified in clause B.2. Table 8 gives an overview of conformance tests for which the artificial antenna shall be selected by the manufacturer.

This method facilitates conducted measurements to be made of the following:

- transmitter loop currents within OFR up to 148,5 kHz;
- transmitter spurious and OOB currents up to 30 MHz.

The artificial antenna of annex C shall be used.

5.5 Test sites and general arrangements for radiated measurements

Tests to be carried out using a test site shall be selected according to table 8.

Due to the mechanical size of the user defined antennas it has to be noted that the emissions test for such dimensions cannot be realized on a turn table. Therefore artificial antennas or a representative test garden shall be used.

This method facilitates radiated measurements to be made of the following:

- RMI radiated H-field within OFR up to 148,5 kHz;
- RMI spurious and OOB H-field up to 30 MHz.

The required test setups and procedures are provided in annex B.

5.6 Measuring receiver

The term "measuring receiver" refers to a selective voltmeter, oscilloscope or a spectrum analyser. The bandwidth and detector type of the measuring receiver are given in table 7.

If a different detector type shall be used for the conformance test this is specified in the related subclauses of clause 6.

Table 7: Bandwidth and detector type for the measuring receiver

Frequency: (f)	Detector type	Measurement receiver bandwidth	Spectrum analyser bandwidth
$300 \text{ Hz} \leq f < 9 \text{ kHz}$	Quasi Peak	200 Hz	300 Hz
$9 \text{ kHz} \leq f < 150 \text{ kHz}$	Quasi Peak	200 Hz	300 Hz
$150 \text{ kHz} \leq f < 30 \text{ MHz}$	Quasi Peak	9 kHz	10 KHz
$30 \text{ MHz} \leq f \leq 1\,000 \text{ MHz}$	Quasi Peak	120 kHz	100 kHz

Different bandwidths may be used if agreed with the test laboratory. The measurement bandwidths and any related calculations shall be stated in the test report.

5.7 Measurement uncertainty

The provisions of ETSI EN 300 330 [1], clause 5.13 shall apply.

5.8 Interpretation of the measurement results

The provisions of ETSI EN 300 330 [1], clause 5.14 shall apply.

6 Conformance methods of measurement for transmitters and receivers

6.1 General

For the conformance test of the essential requirements in clause 4, table 8 gives an overview of the relevant conformance tests and test conditions for the essential requirements, which shall be selected by the manufacturer.

Table 8: Overview of Conformance tests

Essential requirements	Conformance tests	Test setup and procedure		Test conditions	Measurement uncertainty
		User defined antennas	Factory defined antenna		
OFR, clause 4.3.1	6.2.1	B.1 or B.2	B.1 or B.3	5.3	5.7
H-field, clause 4.3.2	6.2.2	B.1 or B.2	B.1 or B.3	5.3	5.7
Transmitter unwanted emission (spurious and out of band emissions), clauses 4.3.3 and 4.3.4	6.2.3	for $f < 30 \text{ MHz}$: B.1 or B.2 for $30 \text{ MHz} < f < 1 \text{ GHz}$: not applicable	B.1 or B.3	5.3	5.7
Receiver Blocking, clause 4.4.3	6.3.2	B.1	B.1	5.3	5.7

6.2 Transmitter conformance methods

6.2.1 OFR

The measurement shall be made with one of the test setups from annex B. For user defined loops (guidance and boundary wires) the test setup and procedure from clause B.1 (test garden) or clause B.2 (artificial antenna) and for factory defined antennas the test setup and procedure from clause B.1 (test garden) or from clause B.3 (anechoic chamber) shall be used.

A representative test signal from the RMI shall be measured with a spectrum analyser. The RMI system shall be modulated with standard test modulation (see clause 5.2).

The transmission shall be measured using a spectrum analyser with the following settings:

- Start frequency: 500 Hz.
- Stop frequency: higher than the upper edge of the permitted frequency range/requested by the essential requirements in clause 4.
- Resolution Bandwidth: 200 Hz.
- Video Bandwidth: ≥ 300 Hz.
- Detector mode: RMS.
- Display mode: maxhold over > 10 s.
- Sweep time, Averaging time: ≥ 1 ms per sweep point.

The following values shall be recorded:

- f_H as the frequency of the upper marker resulting from the "OBW"-function of a spectrum analyser, using 99 % of the power (see figure 2). Alternatively the frequency above the centre frequency f_c shall be recorded where the level is 23 dB lower as the maximum.
- f_L as the frequency of the upper marker resulting from the "OBW"-function of a spectrum analyser, using 99 % of the power (see figure 2). Alternatively the frequency below the centre frequency shall be recorded where the level is 23 dB lower as the maximum.
- f_c is the centre frequency. $f_c = \frac{f_H + f_L}{2}$.
- OFR = $f_H - f_L$.

The results are to be compared with the limits in clause 4.3.1.3.

6.2.2 H-field

The measurement shall be made with one of the test setups from annex B. For user defined loops (guidance and boundary wires) the test setup and procedure from clause B.1 (radiated tests with test garden) or clause B.2 (current measurements with artificial antenna) and for factory defined antennas the test setup and procedure from clause B.1 (test garden) or from clause B.3 (radiated tests within anechoic chamber) shall be used.

A representative test signal from the RMI shall be measured with a spectrum analyser. The RMI system shall be modulated with standard test modulation (see clause 5.2).

The transmission shall be measured using a spectrum analyser with the following settings:

- Start frequency: 500 Hz.
- Stop frequency: higher than f_H from clause 4.3.1.
- Resolution Bandwidth: according to clause 5.6.

- Video Bandwidth: \geq RBW.
- Detector mode: according to clause 5.6.
- Display mode: maxhold over > 10 s.
- Sweep time, Averaging time: \geq 1 ms per sweep point.

The maximum H-Field results are to be compared with the limits in clause 4.3.2.3.

6.2.3 Transmitter unwanted emissions (spurious and OOB emissions)

The measurement shall be made with one of the test setups and procedures from annex B. For user defined loops (guidance and boundary wires) the test setup and procedure from clause B.1 (radiated tests with test garden) or clause B.2 (current measurements with artificial antenna) and for factory defined antennas the test setup and procedure from clause B.1 (test garden) or from clause B.3 (radiated tests within anechoic chamber) shall be used.

A representative test signal from the RMI shall be measured with a spectrum analyser. The RMI system shall be modulated with standard test modulation (see clause 5.2).

The transmission shall be measured using a spectrum analyser with the following settings:

- Start frequency: 9 kHz.
- Stop frequency: 1 GHz.
- Resolution Bandwidth: according to clause 5.6.
- Video Bandwidth: \geq RBW.
- Detector mode: according to clause 5.6.
- Display mode: maxhold over > 10 s.
- Sweep time, Averaging time: \geq 1 ms per sweep point.

The maximum unwanted emission (spurious and OOB) results are to be compared with the limits in clause 4.3.3.3.

6.3 Receiver conformance methods

6.3.1 Receiver spurious emissions

Not applicable, see clause 4.4.2.

6.3.2 Receiver blocking

This measurement shall be performed under normal conditions.

The fulfillment of the RMI performance criteria in the operational mode (see clause 4.2.2.2) shall be tested in presence of an inference signal according to clause 4.4.3.3, table 6 (frequencies, magnetic field).

The RMI shall initially operate without interference.

The test setup is visualized in figure 4 and figure 5.

The RMI docking station shall be operated with a boundary wire according to figure 4 and figure 5 with an artificial antenna (or artificial load with 2 Ohm and 200 μ H, see clause B.2.1) as load in series.

The test shall be carried out inside a test chamber according to clause C.1.1 and clause C.1.2 in ETSI EN 300 330 [1].

A test loop with a radius R shall be used to create an interfering magnetic field. The test loop shall lie on a non-metallic ground and the minimum distance to metallic ground plane shall be 0,75 m. The test loop and the boundary wire shall be on the same horizontal level.

The geometrical centre of the receiver(s) in the robotic mower shall be placed to the centre of the test-loop (e.g. $X=0$ (see figure 5)) and shall stay there during the test (e.g. the robotic mower wheels may be deactivated or lifted from the ground). Any possible switch off mechanism (e.g. if the robotic mower detects no movement) shall not affect the test.

The radius R of the test-loop shall be in minimum 4 times the maximum dimension r of the robotic mower (see figure 5).

The maximum interfering H-Field at $X = 0$ can be calculated from the loop current I (into the test-loop) with the following formula:

$$H = \frac{I}{2R} \quad (1)$$

The required output current to achieve the magnetic field from clause 4.4.3.3, table 6 at the robotic mower shall be generated with a test signal generator at the test frequencies from table 6.

For each test frequency the "reaction" of the RMI shall be recorded and checked against the performance criteria from clause 4.2.1.

The RX test includes two separate test scenarios:

- Test 1: if the robotic mower can handle a lost signal.
- Test 2: if the robotic mower can handle a passage of the boundary wire.

Test 1: Test if robotic mower can handle a lost signal

Step 1.1: Initially, the test signal generator shall be switched off.

Step 1.2: The RMI system shall be configured so that the wanted performance criteria are met: the wanted criteria are considered to be met as long as the receiver always works as intended. Calculate the limit of the interferer current according to clause 4.4.3.3, table 6 and equation (1).

Step 1.3: The test signal generator is then switched on at f_C .

Step 1.4: The test signal generator shall then be adjusted in carrier current from zero up to the limit given in clause 4.4.3.3, table 6.

Step 1.5: If the robotic mower goes into safe mode or into a state which is not declared then this magnetic field shall be noted.

Step 1.6: With the interferer limit according to clause 4.4.3.3, table 6, turn off the RMI transmitter, so there is only the signal from the interferer. The robotic mower has to detect the loss of its signal and go into safe mode (see clause 4.2.1).

Step 1.7: The measurements steps 1.1 to 1.6 shall be repeated at the frequency for OOB and remote-signal as requested in clause 4.4.3.3, table 6.

If the RMI meets the wanted performance criteria (see clause 4.2.1) at all times, then the test shall be considered as passed.

Otherwise, the test is considered as failed.

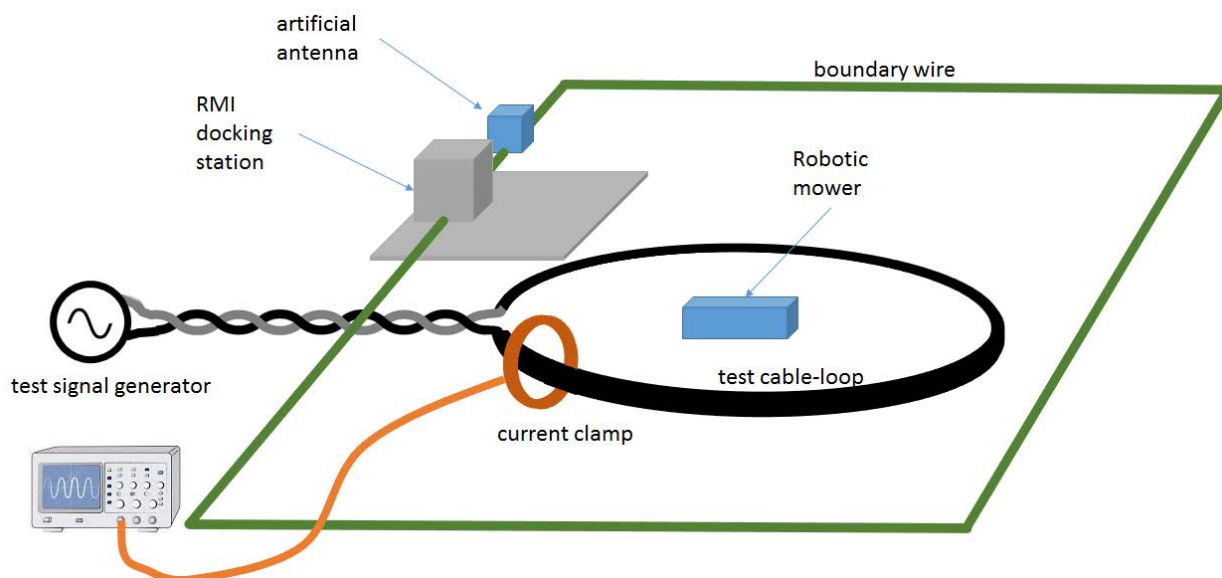

Figure 4: Schematic test set-up for the RX-blocking test 1

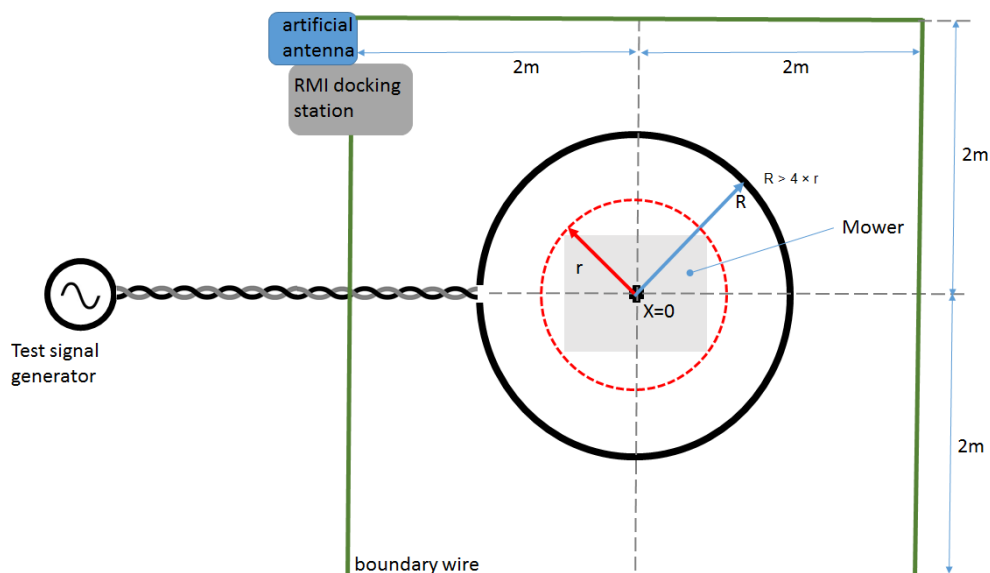

Figure 5: Schematic test set-up for the RX-blocking test 1

Test 2: Test if robotic mower can handle a passage of the boundary wire

Step 2.1: Initially, the test signal generator shall be switched off.

Step 2.2: The RMI system shall be configured so that the wanted performance criteria are met: the wanted criteria are considered to be met as long as the RMI system works as intended. Calculate the limit of the interferer current according to clause 4.4.3.3, table 6 and equation (1).

Step 2.3: The test signal generator is then switched on at f_C .

Step 2.4: The test signal generator should then be adjusted in carrier current from zero up to the limit given in clause 4.4.3.3, table 6.

Step 2.5: The boundary wire should then be moved under or over the robotic mower so that the robotic mower is outside the boundary wire (leaving the working area). The boundary wire should never be moved faster than the speed of the robotic mower so that a normal mode boundary wire passage can be observed, see figure 6.

Step 2.6: The robotic mower should indicate to fulfil the performance criteria from clause 4.2.1.

Step 2.7: The measurements steps 2.3 to 2.6 shall be repeated at the frequency for OOB and remote-signal as requested in clause 4.4.3.3, table 6.

If the robotic mower operates in normal mode or in safe mode at all times, then the test shall be considered as passed.

If the robotic mower does not react as intended, then the test is considered as failed.

The results are to be compared with the limits in clause 4.4.3.3.

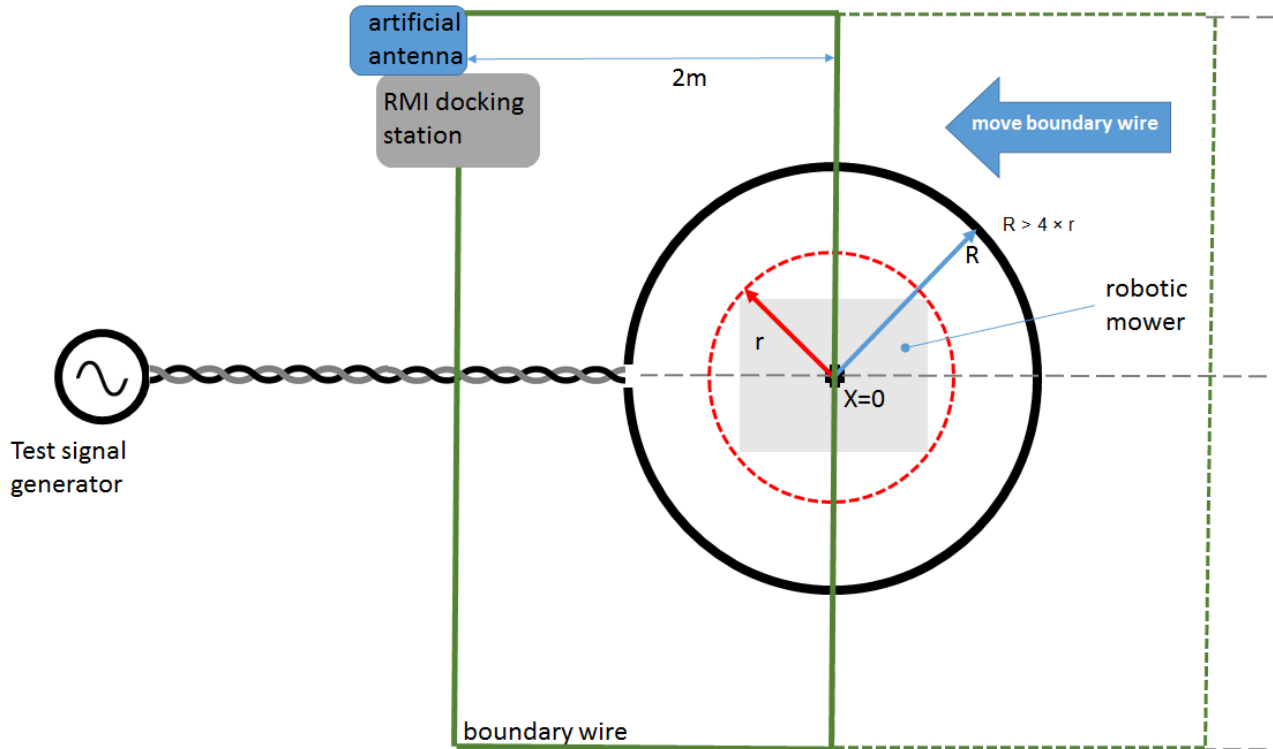

Figure 6: Schematic test set-up for the RX-blocking test 2

Annex A (informative): Relationship between the present document and the essential requirements of Directive 2014/53/EU

The present document has been prepared under the Commission's standardisation request C(2015) 5376 final [i.6] to provide one voluntary means of conforming to the essential requirements of Directive 2014/53/EU on the harmonisation of the laws of the Member States relating to the making available on the market of radio equipment and repealing Directive 1999/5/EC [i.3].

Once the present document is cited in the Official Journal of the European Union under that Directive, compliance with the normative clauses of the present document given in table A.1 confers, within the limits of the scope of the present document, a presumption of conformity with the corresponding essential requirements of that Directive and associated EFTA regulations.

Table A.1: Relationship between the present document and the essential requirements of Directive 2014/53/EU

Harmonised Standard ETSI EN 303 447				
Requirement			Requirement Conditionality	
No	Description	Reference: Clause No	U/C	Condition
1	Operating frequency range	4.3.1	U	
2	Transmitter H-field requirements	4.3.2	U	
3	Transmitter spurious emissions	4.3.3	U	
4	Transmitter out of band (OOB) emissions	4.3.4	U	
5	Receiver blocking	4.4.3	U	

Key to columns:

Requirement:

No A unique identifier for one row of the table which may be used to identify a requirement.

Description A textual reference to the requirement.

Clause Number Identification of clause(s) defining the requirement in the present document unless another document is referenced explicitly.

Requirement Conditionality:

U/C Indicates whether the requirement is unconditionally applicable (U) or is conditional upon the manufacturer's claimed functionality of the equipment (C).

Condition Explains the conditions when the requirement is or is not applicable for a requirement which is classified "conditional".

Presumption of conformity stays valid only as long as a reference to the present document is maintained in the list published in the Official Journal of the European Union. Users of the present document should consult frequently the latest list published in the Official Journal of the European Union.

Other Union legislation may be applicable to the product(s) falling within the scope of the present document.

Annex B (normative): Test sites and procedures

B.1 Set-up 1: Magnetic field measurements at a Test Garden

The test shall be performed for each user defined loop separately.

The test garden is a 20 m × 10 m garden. The transmitter antenna is bounding the edges of the garden.

The measurement point A is located at a distance of 10 m from the middle of the long side (see figure B.1). The measurement antenna shall be there at a height of 1 m.

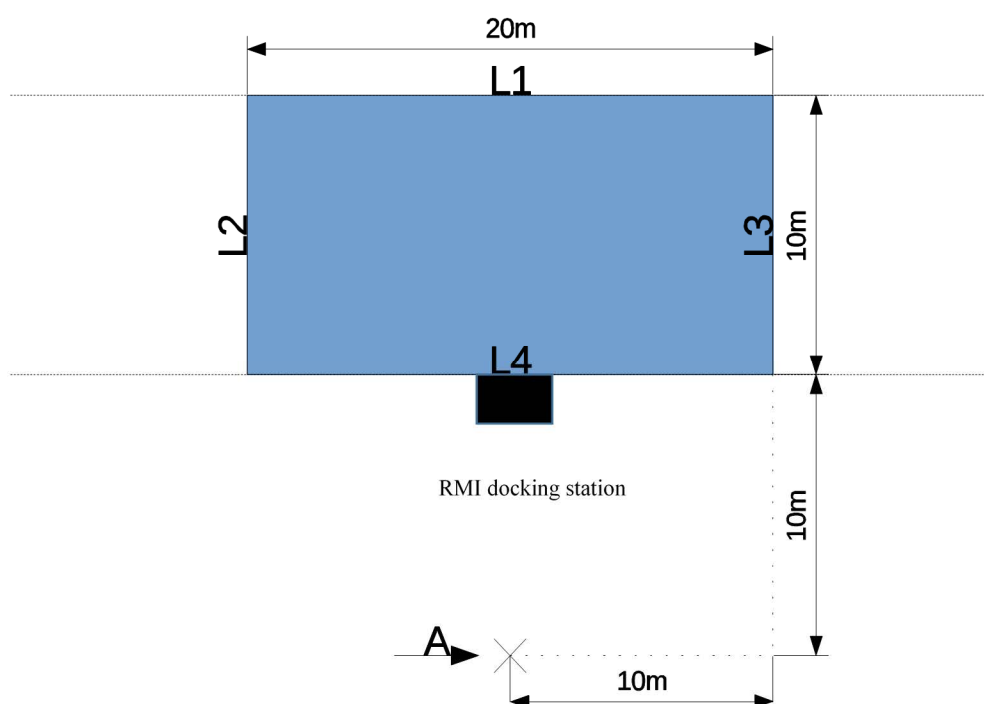

Figure B.1: The test garden

Requirements for the open test site are described in ETSI EN 300 330 [1], clause C.1.3.

The maximum transmissions at 10 m distance are to be recorded with the three possible orthogonal orientations (x/y/z) of the shielded loop antenna in the direction of the maximum radiation of the RMI system.

B.2 Set-up 2: Carrier current measurements using an artificial antenna

B.2.1 General

The test shall be performed for each user defined loop separately (independent and dependent loops). Independent loops are electrically connected only inside the RMI docking station while dependent loops are electrically connected outside the RMI docking station, e.g. by a T-junction.

- For each independent user defined loop:
 - The test shall be performed for each independent user defined loop separately while all other loops are connected to artificial loads in order to keep the RMI system in normal operation, e.g. one resistor of 2 Ω and one inductor of 200 μH in series if not otherwise specified by the manufacturer.
 - The transmitter of the RMI shall be connected to an artificial antenna according to clause 5.4.
- For dependent user defined loops:
 - The test shall be performed for each dependent user defined loop separately.
 - The transmitter of the RMI shall be connected to an artificial antenna according to clause 5.4, so every combination of possible single loops is measured once. If needed for function of the RMI an artificial load shall be connected to ports that enables function of the RMI, e.g. one resistor of 2 Ω and one inductor of 200 μH in series if not otherwise specified by the manufacturer.

The measuring receiver shall be connected to the current clamps of the measurement setup.

Tests shall be performed for differential mode (DM, see clause B.2.2) and common mode (CM, see clause B.2.3) separately.

B.2.2 Differential mode measurement

The differential mode current I_{DM} delivered to the artificial antenna during a transmission duty cycle shall be measured up to 30 MHz. The maximum H-field shall be calculated from the current I_{DM} using formula (B.1):

$$H/\text{dB}\mu\text{A}/\text{m at } 10 \text{ m} = I_{\text{DM}}/\text{dB}\mu\text{A} - \text{CF}$$

$$\text{for } f < 1 \text{ MHz: CF} = 46 \quad (\text{B.1})$$

$$\text{for } 1 \text{ MHz} < f < 30 \text{ MHz: CF} = 39$$

NOTE: The conversion factor CF has been derived by a full Maxwell solution for the standard test garden antenna with a simulation software.

B.2.3 Common mode measurement

The common mode current I_{CM} delivered to the artificial antenna during a transmission duty cycle shall be measured between 1 MHz and 30 MHz. The maximum H-field shall be calculated from the current I_{CM} using formula (B.2):

$$H/\text{dB}\mu\text{A}/\text{m at } 10 \text{ m} = I_{\text{CM}}/\text{dB}\mu\text{A} - \text{CF}$$

$$\text{CF} = 39,5 + 5,4 \times \log_{10}(f[\text{MHz}]) \quad (\text{B.2})$$

NOTE: The conversion factor CF has been derived by a full Maxwell solution for the standard test garden antenna with a simulation software.

B.3 Radiated measurements using anechoic chamber or open area test site

The measurements shall be made according to clause 6.2 of ETSI EN 300 330 [1].

For the spurious emission test > 30 MHz in an anechoic test chamber the artificial antenna according to clause 5.4 or an equivalent load shall be used as load for user defined antennas.

Annex C (normative): Artificial antenna for conducted measurements below 30 MHz

The artificial antenna is used for equipment with an antenna connector and submitted for testing without an antenna. The radiated fields are a function of the RF energy radiated by the currents. Therefore, measurements are made to determine those currents in the artificial antenna.

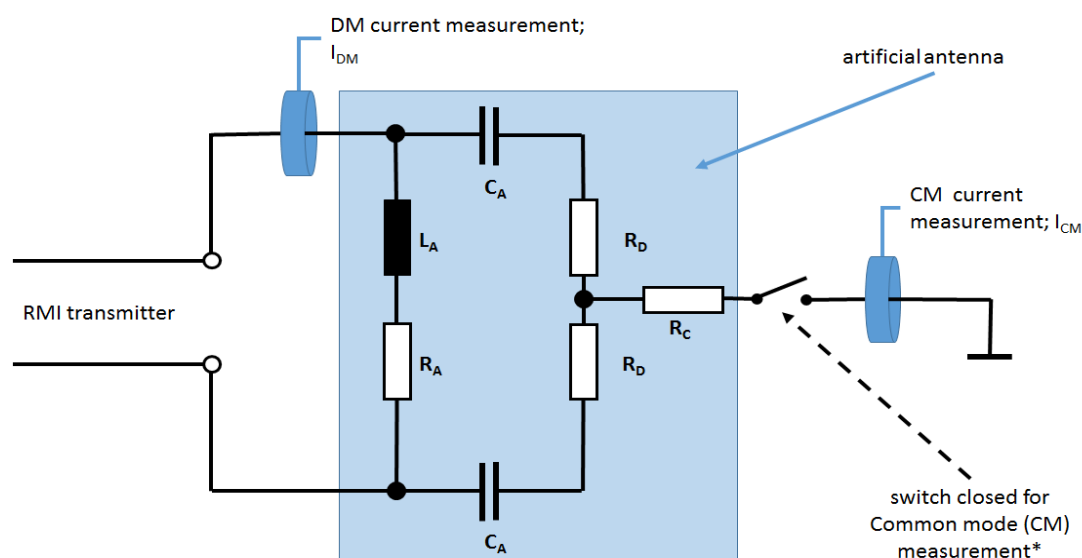

* switch could also be realised as a simple cable connector

Figure C.1: Schematic of artificial antenna

The artificial antenna consists of one resistor (R_A) and one inductor (L_A) in series connected to the boundary wire connector of the RMI docking station. The total impedance shall be $R_A = 2 \Omega \pm 1 \%$ in series with $L_A = 200 \mu\text{H} \pm 5 \%$. The manufacturer can declare other values for the artificial antenna parameters but then he shall verify the parameters in the test report.

The capacitors $C_A = 40 \text{ nF} \pm 5 \%$

The resistors $R_D = 75 \Omega \pm 5 \%$

The resistor $R_C = 110 \Omega \pm 5 \%$

NOTE 1: The values have been chosen so, that the high frequency current path does not affect the impedance of the artificial antenna in the operating frequency range. The high frequency differential mode impedance of 150Ω has been identified as worst case real part of the standard test garden loop in the frequency range between 150 kHz and 30 MHz.

The artificial antenna shall be put in a shielded box. It shall be taken care when choosing the layout and components to avoid resonances within the measurement frequency range. Between 150 kHz to 30 MHz both the differential mode impedance and the common mode impedance shall always be within a magnitude of $150 \Omega \pm 40 \Omega$.

To verify the common mode impedance of the artificial antenna both inputs shall be shorten and used as one terminal (Point A) and the related second terminal is Point B, see figure C.2.

NOTE 2: For the verification of the artificial antenna common mode impedance, the antenna needs to be disconnected from the RMI transmitter.

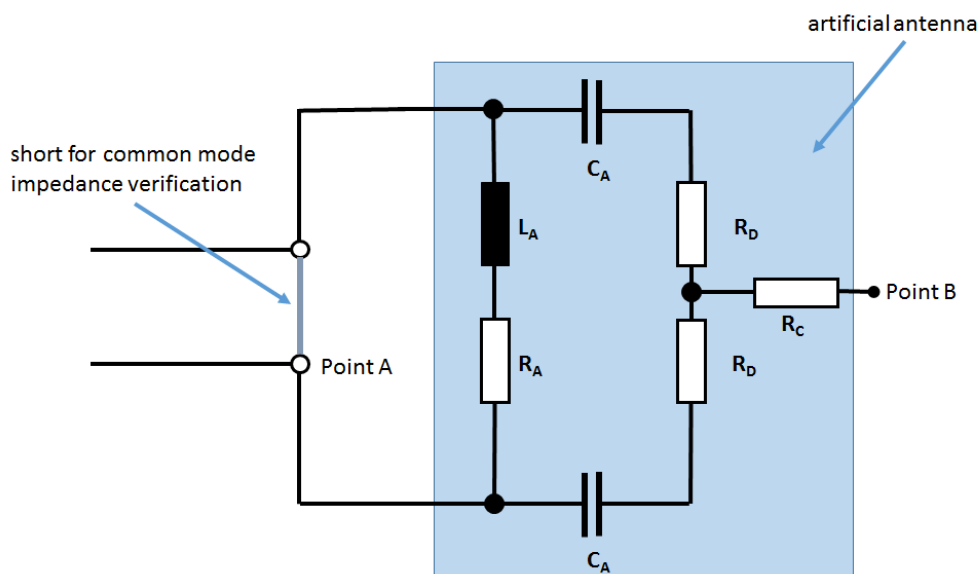

Figure C.2: Schematic for the verification of the artificial antenna common mode impedance

The inductance at 10 kHz shall be verified that it is within $\pm 20\%$ of 200 μH .

For the mechanical/electrical realization of the artificial antenna it shall be taken into account that the current into the antenna can be larger than 1 A. This current into 2 Ohm would create a loss of power of min. 2 W in this resistor. This power needs to be taken into account when choosing the electronic parts for the artificial antenna.

The saturation current of the inductor shall be at least 2 A or $1,5 \times$ peak current of the RMI docking station.

Mechanical setup:

- The equipment shall be placed on a horizontal metal ground plane (reference ground plane), but isolated from it by a non-metallic support of $0,1 \text{ m} \pm 25\%$ in height.
- The lead wire shall be led downward along the RMI docking station to the level of the non-metallic support and be led horizontally to the artificial antenna.
- The artificial antenna shall be bonded to the reference ground plane as short as possible. The reference ground plane shall extend at least 0,5 m beyond the boundaries of the RMI docking station and shall have minimum dimensions of 2 m by 2 m.
- The RMI docking station is connected as short as possible to the artificial antenna by a twisted 2 lead wire except where the current clamp is. The distance from the outer boundary of the RMI docking station to the artificial antenna shall not exceed 30 cm.
- The differential mode current clamp shall be placed at one of the two lead wires a maximum of 5 cm away from the artificial antenna input port, see figure C.3.
- The common mode current clamp shall be placed on the ground wire above the non-metallic support, see figure C.3.

NOTE 3: If no switch is available in the artificial antenna, the common mode conductor to the ground plane can alternatively be removed during the differential mode measurement.

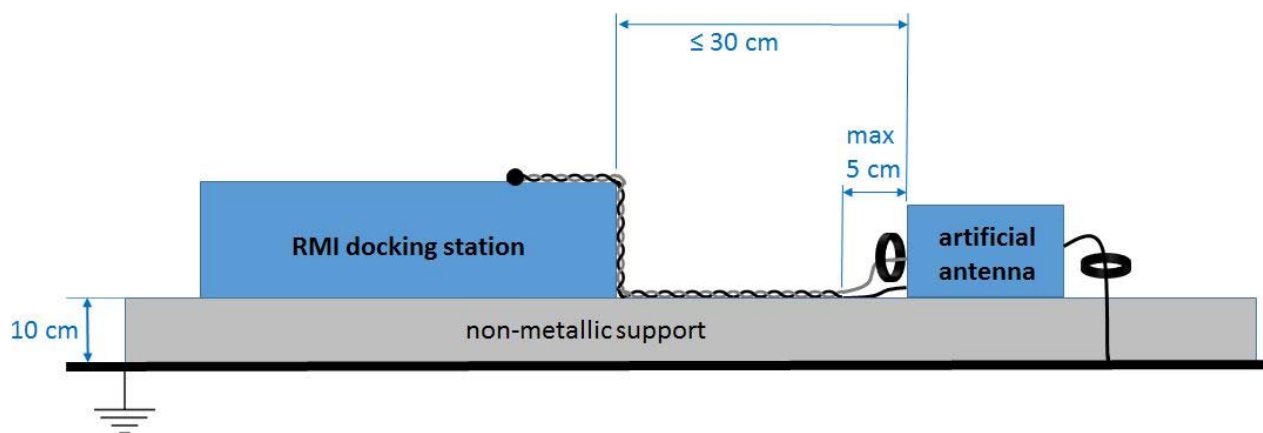

Figure C.3: Mechanical setup for artificial antenna

Annex D (informative): Change history

Version	Information about changes
1.1.1	First version of the present document to cover the essential requirements for RMI systems in the frequency range below 148,5 kHz on article 3.2 of Directive 2014/53/EU [i.3]

History

Document history		
V1.1.0	December 2016	EN Approval Procedure AP 20170315: 2016-12-15 to 2017-03-15
V1.1.1	June 2017	Vote V 20170812: 2017-06-13 to 2017-08-14