



**Electromagnetic compatibility
and Radio spectrum Matters (ERM);
Short Range Devices (SRD) using
Ultra Wide Band technology (UWB);
Harmonized EN covering the essential requirements
of article 3.2 of the R&TTE Directive;
Part 3: Requirements for UWB devices
for road and rail vehicles**

Reference

DEN/ERM-TGUWB-018

Keywords

radio, regulation, SRD, testing, UWB

ETSI

650 Route des Lucioles
F-06921 Sophia Antipolis Cedex - FRANCE

Tel.: +33 4 92 94 42 00 Fax: +33 4 93 65 47 16

Siret N° 348 623 562 00017 - NAF 742 C
Association à but non lucratif enregistrée à la
Sous-Préfecture de Grasse (06) N° 7803/88

Important notice

Individual copies of the present document can be downloaded from:

<http://www.etsi.org>

The present document may be made available in more than one electronic version or in print. In any case of existing or perceived difference in contents between such versions, the reference version is the Portable Document Format (PDF). In case of dispute, the reference shall be the printing on ETSI printers of the PDF version kept on a specific network drive within ETSI Secretariat.

Users of the present document should be aware that the document may be subject to revision or change of status. Information on the current status of this and other ETSI documents is available at

<http://portal.etsi.org/tb/status/status.asp>

If you find errors in the present document, please send your comment to one of the following services:

http://portal.etsi.org/chaicor/ETSI_support.asp

Copyright Notification

No part may be reproduced except as authorized by written permission.
The copyright and the foregoing restriction extend to reproduction in all media.

© European Telecommunications Standards Institute 2014.
All rights reserved.

DECT™, PLUGTESTS™, UMTS™ and the ETSI logo are Trade Marks of ETSI registered for the benefit of its Members.
3GPP™ and LTE™ are Trade Marks of ETSI registered for the benefit of its Members and
of the 3GPP Organizational Partners.
GSM® and the GSM logo are Trade Marks registered and owned by the GSM Association.

Contents

Intellectual Property Rights	5
Foreword.....	5
1 Scope	6
2 References	6
2.1 Normative references	6
2.2 Informative references.....	7
3 Definitions, symbols and abbreviations	8
3.1 Definitions.....	8
3.2 Symbols.....	9
3.3 Abbreviations	9
4 Technical requirements specification	9
4.1 Operating bandwidth	9
4.1.1 Definition of operating bandwidth for test procedure.....	9
4.1.2 Test procedure	10
4.1.3 Limit	10
4.1.4 Measurement uncertainty.....	10
4.2 Mean power spectral density	10
4.2.1 Definition.....	10
4.2.2 Test procedure	10
4.2.3 Limit	10
4.2.4 Measurement uncertainty.....	11
4.3 Maximum value of peak power.....	11
4.3.1 Definition.....	11
4.3.2 Test procedure	11
4.3.3 Limit	11
4.3.4 Measurement uncertainty.....	12
4.4 Receiver spurious emissions.....	12
4.4.1 Definition.....	12
4.4.2 Test procedure	13
4.4.3 Limit	13
4.4.4 Measurement uncertainty.....	13
4.5 Exterior Limit	13
4.5.1 Definition.....	13
4.5.2 Test Procedure	14
4.5.3 Limit	14
4.5.4 Measurement uncertainty.....	14
4.6 Transmit Power Control (TPC)	15
4.6.1 Definition.....	15
4.6.2 Test procedure	15
4.6.3 Limit	15
4.6.4 Measurement uncertainty.....	15
4.7 Detect And Avoid (DAA)	15
4.7.1 Definition.....	15
4.7.2 Test procedure	15
4.7.3 Limit	15
4.7.4 Measurement Tolerance.....	15
4.8 Low Duty Cycle (LDC).....	15
4.8.1 Definition.....	15
4.8.2 Test procedure	16
4.8.3 Limit	16
4.9 Equivalent mitigation techniques	16
4.9.1 Other mitigation techniques and mitigation factors	16
4.9.2 Power vs. LDC Tradeoff Method	17

5	Test Requirements	17
5.1	Product information	17
5.2	Requirements for the test modulation	18
5.3	Test conditions, power supply and ambient temperatures	18
5.4	Choice of equipment for test suites	18
5.4.1	Multiple Operating bandwidths and multiband equipment	18
5.5	Testing of host connected equipment and plug-in radio devices	18
5.6	Interpretation of the measurement results	18
5.6.1	Measurement uncertainty is equal to or less than maximum acceptable uncertainty	19
5.6.2	Measurement uncertainty is greater than maximum acceptable uncertainty	19
5.7	Emissions	20
6	Test setups and procedures	20
6.1	Introduction	20
6.2	Initial Measurement steps	20
6.3	Radiated measurements	20
6.3.1	General	20
6.3.2	Test sites and general arrangements for measurements involving the use of radiated fields	20
6.3.3	Guidance on the use of a radiation test site	20
6.3.3.1	Range length	20
6.3.4	Coupling of signals	21
6.3.5	Standard test methods	21
6.3.5.1	Generic measurement method	21
6.3.5.1.1	Calibrated setup	21
6.3.5.1.2	Substitution method	22
6.3.5.2	Spherical scan with automatic test antenna placement	23
6.3.5.2.1	Calibrated setup	23
6.3.5.2.2	Substitution method	24
6.3.5.3	Spherical scan with rotating and tilting the DUT	24
6.3.5.3.1	Calibrated setup	25
6.3.5.3.2	Substitution method	25
6.3.5.4	Spherical scan other methods	26
6.3.6	Standard calibration method	26
6.4	Conducted measurements	26
7	Test procedures for essential radio test suites	26
7.1	General	26
7.2	Test Procedure	27
7.3	Method of measurements of the Ultra Wideband Emissions	28
7.4	Mean power spectral density measurements	28
7.5	Peak power spectral density measurements	29
7.6	Operating bandwidth	29
7.7	Receiver spurious emissions	29
7.8	Transmitter Power Control	29
7.9	Low Duty Cycle	29
7.10	Detect and Avoid Mechanisms	29
7.11	Exterior Limit	29
Annex A (normative):	HS Requirements and conformance Test specifications Table (HS-RTT)	30
Annex B (informative):	Measurement antenna, preamplifier, and cable specifications	32
Annex C (informative):	Surface mounted devices example mirror	33
Annex D (normative):	Device mounted inside the tyre	35
Annex E (informative):	Bibliography	37
History		38

Intellectual Property Rights

IPRs essential or potentially essential to the present document may have been declared to ETSI. The information pertaining to these essential IPRs, if any, is publicly available for **ETSI members and non-members**, and can be found in ETSI SR 000 314: "*Intellectual Property Rights (IPRs); Essential, or potentially Essential, IPRs notified to ETSI in respect of ETSI standards*", which is available from the ETSI Secretariat. Latest updates are available on the ETSI Web server (<http://ipr.etsi.org>).

Pursuant to the ETSI IPR Policy, no investigation, including IPR searches, has been carried out by ETSI. No guarantee can be given as to the existence of other IPRs not referenced in ETSI SR 000 314 (or the updates on the ETSI Web server) which are, or may be, or may become, essential to the present document.

Foreword

This final draft Harmonized European Standard (EN) has been produced by ETSI Technical Committee Electromagnetic compatibility and Radio spectrum Matters (ERM), and is now submitted for the Vote phase of the ETSI standards EN Approval Procedure.

The present document has been produced by ETSI in response to mandate M/407 issued from the European Commission under Directive 98/34/EC [i.9] as amended by Directive 98/48/EC [i.12].

The title and reference to the present document are intended to be included in the publication in the Official Journal of the European Union of titles and references of Harmonized Standard under the Directive 1999/5/EC [i.10].

See article 5.1 of Directive 1999/5/EC [i.10] for information on presumption of conformity and Harmonized Standards or parts thereof the references of which have been published in the Official Journal of the European Union.

The requirements relevant to Directive 1999/5/EC [i.10] are summarized in Annex A.

Equipment covered by the present document operates in accordance with ECC/DEC(06)04 [i.11] "The harmonised conditions for devices using Ultra-Wideband (UWB) technology in bands below 10,6 GHz" in road and railway vehicles.

The present document is part 3 of a multi-part deliverable covering Short Range Devices (SRD) using Ultra Wide Band technology (UWB) for communication purposes, as identified below:

- Part 1: "Requirements for Generic UWB applications";
- Part 2: "Requirements for UWB location tracking";
- Part 3: "Requirements for UWB devices for road and rail vehicles".**

Proposed national transposition dates	
Date of latest announcement of this EN (doa):	3 months after ETSI publication
Date of latest publication of new National Standard or endorsement of this EN (dop/e):	6 months after doa
Date of withdrawal of any conflicting National Standard (dow):	18 months after doa

1 Scope

The present document applies to transceivers, transmitters and receivers utilizing Ultra WideBand (UWB) technologies and used for short range applications in road and rail vehicles, which includes devices mounted inside or at the surface. The present document applies to impulse, modified impulse and RF carrier based UWB technologies in the main operating frequency ranges from 3,1 GHz to 4,8 GHz or from 6 GHz to 9 GHz.

Examples of applications for road and rail vehicles are:

- stand-alone radio equipment with or without its own control provisions;
- plug-in radio devices intended for use with, or within, a variety of host systems, e.g. personal computers, etc.;
- plug-in radio devices intended for use within combined equipment, e.g. modems, access points, etc.;
- equipment for telemetry communication inside and outside of road and rail vehicles;
- equipment for the localization of devices inside and outside of road and rail vehicles (e.g. hand-held devices);
- equipment to investigate materials (e.g. fuel).

The present document does not apply to fixed road infrastructure installations. For fixed rail infrastructure tracking applications see [i.5] and [i.6].

The present document applies to UWB equipment with an output connection used with a dedicated antenna or UWB equipment with an integral antenna.

The present document applies to UWB equipment conforming to ECC/DEC/(06)04 amended 9 December 2011 [i.11] and CEPT report 45 [i.13].

2 References

References are either specific (identified by date of publication and/or edition number or version number) or non-specific. For specific references, only the cited version applies. For non-specific references, the latest version of the referenced document (including any amendments) applies.

Referenced documents which are not found to be publicly available in the expected location might be found at <http://docbox.etsi.org/Reference>.

NOTE: While any hyperlinks included in this clause were valid at the time of publication, ETSI cannot guarantee their long term validity.

2.1 Normative references

The following referenced documents are necessary for the application of the present document.

- [1] ETSI TS 102 883 (V1.1.1) (08-2012): "Electromagnetic compatibility and Radio spectrum Matters (ERM); Short Range Devices (SRD) using Ultra Wide Band (UWB); Measurement Techniques".
- [2] ETSI TS 102 754 (V1.2.1) (11-2008): "Electromagnetic compatibility and Radio spectrum Matters (ERM); Short Range Devices (SRD); Technical characteristics of Detect-And-Avoid (DAA) mitigation techniques for SRD equipment using Ultra Wideband (UWB) technology".
- [3] ETSI TR 100 028 (all parts) (V1.4.1) (12-2001): "Electromagnetic compatibility and Radio spectrum Matters (ERM); Uncertainties in the measurement of mobile radio equipment characteristics".

2.2 Informative references

The following referenced documents are not necessary for the application of the present document but they assist the user with regard to a particular subject area.

- [i.1] ETSI TR 102 070-2: "Electromagnetic compatibility and Radio spectrum Matters (ERM); Guide to the application of harmonized standards to multi-radio and combined radio and non-radio equipment; Part 2: Effective use of the radio frequency spectrum".
 - [i.2] ETSI TR 103 086: "Electromagnetic compatibility and Radio spectrum Matters (ERM); Short Range Devices (SRD); Conformance test procedure for the exterior limit tests in EN 302065-3 UWB applications in the ground based vehicle environment".
 - [i.3] ECC Report 120 (March 2008): "ECC Report on Technical requirements for UWB DAA (Detect and avoid) devices to ensure the protection of radiolocation in the bands 3.1-3.4 GHz and 8.5-9 GHz and BWA terminals in the band 3.4-4.2 GHz".
 - [i.4] Commission Decision 2007/131/EC of 21 February 2007 on allowing the use of the radio spectrum for equipment using ultra-wideband technology in a harmonised manner in the Community (notified under document number C(2007) 522).
- NOTE: This EC Decision is currently under revision based on CEPT report 45 [i.13] and amended ECC/DEC(06)04 [i.11]. The new EC/DEC revision is expected within 2014.
- [i.5] ETSI TR 101 538: "Electromagnetic compatibility and Radio spectrum Matters (ERM); Short Range Devices (SRD); UWB location tracking devices in the railroad environment".
 - [i.6] ETSI TS 103 085: "Electromagnetic compatibility and Radio spectrum Matters (ERM); Short Range Devices (SRD) using Ultra Wide Band (UWB) for Location and Tracking railroad applications; RF conformance testing".
 - [i.7] CEPT/ERC Recommendation 74-01: "Unwanted emissions in the spurious domain".
 - [i.8] Void.
 - [i.9] Directive 1998/34/EC as amended by 1998/48/EC the European Parliament and of the Council of 22 June 1998 laying down a procedure for the provision of information in the field of technical standards and regulations.
 - [i.10] Directive 1999/5/EC of the European Parliament and of the Council of 9 March 1999 on radio equipment and telecommunications terminal equipment and the mutual recognition of their conformity (R&TTE Directive).
 - [i.11] CEPT ECC/DEC(06)04 of 24 March 2006 amended 9 December 2011: "The harmonised conditions for devices using Ultra-Wideband (UWB) technology in bands below 10.6 GHz".
 - [i.12] Directive 98/48/EC of the European Parliament and of the Council of 20 July 1998 amending Directive 98/34/EC laying down a procedure for the provision of information in the field of technical standards and regulations.
 - [i.13] CEPT report 45: "Report from CEPT to the European Commission in response to the Fifth Mandate to CEPT on ultra-wideband technology to clarify the technical parameters in view of a potential update of Commission Decision 2007/131/EC". Report approved on 21 June 2013 by the ECC.

3 Definitions, symbols and abbreviations

3.1 Definitions

For the purposes of the present document, the following terms and definitions apply:

combined equipment: any combination of non-radio equipment and a plug-in radio device that would not offer full functionality without the radio device

dedicated antenna: removable antenna supplied and tested with the radio equipment, designed as an indispensable part of the equipment

detect and avoid time: time duration between a change of the external RF environmental conditions and adaptation of the corresponding UWB operational parameters

dwelt time: duration of a transmission on a particular sub-channel

effective radiated power (e.r.p.): product of the power supplied to the antenna and its gain relative to a half-wave dipole in a given direction (RR 1.162)

equivalent isotropically radiated power (e.i.r.p.): product of the power supplied to the antenna and the antenna gain in a given direction relative to an isotropic antenna (absolute or isotropic gain) (RR 1.161)

gating: transmission that is intermittent or of a low duty cycle referring to the use of burst transmissions where a transmitter is switched on and off for selected time intervals

hopping: spread spectrum technique whereby individual radio links are continually switched from one subchannel to another

hopping cycle: number of hopping positions for a full frequency hopping sequence

host: host equipment is any equipment which has complete user functionality when not connected to the radio equipment part and to which the radio equipment part provides additional functionality and to which connection is necessary for the radio equipment part to offer functionality

impulse: pulse whose width is determined by its dc step risetime and whose maximum amplitude is determined by its dc step value

integral antenna: permanent fixed antenna, which may be built-in, designed as an indispensable part of the equipment

plug-in radio device: radio equipment module intended to be used with or within host, combined or multi-radio equipment, using their control functions and power supply

pulse: short transient signal whose time duration is nominally the reciprocal of its -10 dB bandwidth

rf carrier: fixed radio frequency prior to modulation

stand-alone radio equipment: equipment that is intended primarily as communications equipment and that is normally used on a stand-alone basis

transmitter off time: time interval between two consecutive bursts when the UWB emission is kept idle

transmitter on time: duration of a burst irrespective of the number of pulses contained

3.2 Symbols

For the purposes of the present document, the following symbols apply:

d	distance
Θ	elevation angle
f	frequency
λ	wavelength
k	coverage factor
φ	azimuth angle
T _{off}	transmitter off time
T _{on}	transmitter on time

3.3 Abbreviations

For the purposes of the present document, the following abbreviations apply:

CEPT	European Conference of Postal and Telecommunications Administrations
DAA	Detect And Avoid
DC	Direct Current
DUT	Device Under Test
e.i.r.p.	equivalent isotropically radiated power
e.r.p.	equivalent radiated power
EC	European Commission
ECC	European Communication Commission
EN	European Norm
FH	Frequency Hopping
LDC	Low Duty Cycle
LNA	Low Noise Amplifier
NF	Noise Figure
OE	Other Emissions
OFDM	Orthogonal Frequency Division Multiple Access
PSD	Power Spectral Density
REC	RECommendation
RF	Radio Frequency
RX	Receiver
TPC	Transmit Power Control
TR	Technical Report
TS	Technical Specification
TX	Transmitter
UWB	Ultra WideBand
VSWR	Voltage Standing Wave Ratio

4 Technical requirements specification

4.1 Operating bandwidth

4.1.1 Definition of operating bandwidth for test procedure

The operating bandwidth is the -13 dBc bandwidth of intended UWB signal transmitted by the equipment.

4.1.2 Test procedure

This test shall either be performed using a radiated (as given in clauses 7.6, 6.3.1 and 6.3.2 of the present document) or conducted measurement procedure as given in TS 102 883 [1].

4.1.3 Limit

The operating bandwidth shall be greater than 50 MHz (at -13 dB relative to the maximum spectral power density).

4.1.4 Measurement uncertainty

The interpretation of the results for the measurements uncertainty shall be as given in TS 102 883 [1], clause 5.7, Table 1.

4.2 Mean power spectral density

4.2.1 Definition

The maximum mean power spectral density (specified as e.i.r.p.) of the radio device, at a particular frequency, is the average power per unit bandwidth (centred on that frequency) radiated in the direction of the maximum level under the specified conditions of measurement.

4.2.2 Test procedure

This test shall be performed using the measurement procedure of clause 7.2 with the method of clause 7.4 for the frequencies as shown in Table 1.

4.2.3 Limit

The maximum mean power spectral density measured using the above test procedure shall not exceed the limits given in Table 1. The limit applies to the highest value found for this power (converted to an e.i.r.p.) over all frequencies, times and operating modes. It is also the highest value found over all directions, either as part of the e.i.r.p. measurement method or by using the maximum antenna gain with a conducted power measurement [1].

Table 1: Maximum value of mean power spectral density limit (e.i.r.p.) [i.13]

Frequency range [GHz]	Without mitigation techniques	With mitigation techniques
$f \leq 1,6$	-90 dBm/MHz	-90 dBm/MHz
$1,6 < f \leq 2,7$	-85 dBm/MHz	-85 dBm/MHz
$2,7 < f \leq 3,1$	-70 dBm/MHz	-70 dBm/MHz
$3,1 < f \leq 3,4$	-70 dBm/MHz	-41,3 dBm/MHz (notes 1 and 2)
$3,4 < f \leq 3,8$	-80 dBm/MHz	-41,3 dBm/MHz (notes 1 and 2)
$3,8 < f \leq 4,2$	-70 dBm/MHz	-41,3 dBm/MHz (notes 1 and 2)
$4,2 < f \leq 4,8$	-70 dBm/MHz	-41,3 dBm/MHz (notes 1 and 2)
$4,8 < f \leq 6$	-70 dBm/MHz	-70 dBm/MHz
$6 < f \leq 8,5$	-53,3 dBm/MHz	-41,3 dBm/MHz (notes 1 and 3)
$8,5 < f \leq 9$	-65 dBm/MHz	-41,3 dBm/MHz (note 2)
$9 < f \leq 10,6$	-65 dBm/MHz	-65 dBm/MHz
$10,6 < f$	-85 dBm/MHz	-85 dBm/MHz
<p>NOTE 1: Within the band 3,1 - 4,8 GHz and 6 - 8,5 GHz, devices implementing Low Duty Cycle (LDC) mitigation technique (see clause 4.8) are permitted to operate with a maximum mean e.i.r.p. spectral density of -41,3 dBm/MHz and a maximum peak e.i.r.p. of 0 dBm defined in 50 MHz. Operation is in addition subject to the implementation of an exterior limit (see clause 4.5) of -53,3 dBm/MHz.</p> <p>NOTE 2: Within the bands 3,1 - 4,8 GHz and 8,5 - 9 GHz, devices implementing Detect And Avoid (DAA) mitigation technique (see clause 4.7) are permitted to operate with a maximum mean e.i.r.p. spectral density of -41,3 dBm/MHz and a maximum peak e.i.r.p. of 0 dBm defined in 50 MHz. Operation is in addition subject to the implementation of Transmit Power Control (TPC) mitigation technique (see clause 4.6) and an exterior limit (see clause 4.5) of -53,3 dBm/MHz.</p> <p>NOTE 3: within the band 6 - 8,5 GHz devices implementing Transmit Power Control (TPC) mitigation technique (see clause 4.6) and an exterior limit (see clause 4.5) of -53,3 dBm/MHz are permitted to operate with a maximum mean e.i.r.p. spectral density of -41,3 dBm/MHz and a maximum peak e.i.r.p. of 0 dBm defined in 50 MHz.</p>		

Table 1 is based upon CEPT 45 [i.13]. The EC/DEC on UWB [i.4] is currently under revision. The amended EC/DEC is expected within 2014.

4.2.4 Measurement uncertainty

The interpretation of the results for the measurements uncertainty shall be as given in TS 102 883 [1], clause 5.7, Table 1.

4.3 Maximum value of peak power

4.3.1 Definition

The peak power specified as e.i.r.p. contained within a 50 MHz bandwidth at the frequency at which the highest mean radiated power occurs, radiated in the direction of the maximum level under the specified conditions of measurement.

4.3.2 Test procedure

This test shall be performed using the measurement procedure of clause 7.2 with the method of clause 7.5 for the frequencies as shown in Table 2.

4.3.3 Limit

The maximum peak power limit measured using the above test procedure shall not exceed the limits given in Table 2. The limit applies to the highest value found for this power (converted to an e.i.r.p.) over all frequencies, times and operating modes. It is also the highest value found over all directions, either as part of the e.i.r.p. measurement method or by using the maximum antenna gain with a conducted power measurement [1].

Table 2: Maximum peak power limit [i.13]

Frequency range [GHz]	Without mitigation techniques (defined in 50 MHz)	With mitigation techniques (defined in 50 MHz)
$f \leq 1,6$	-50 dBm	-50 dBm
$1,6 < f \leq 2,7$	-45 dBm	-45 dBm
$2,7 < f \leq 3,1$	-36 dBm	-36 dBm
$3,1 < f \leq 3,4$	-36 dBm	0 dBm (notes 1 and 2)
$3,4 < f \leq 3,8$	-40 dBm	0 dBm (notes 1 and 2)
$3,8 < f \leq 4,2$	-30 dBm	0 dBm (notes 1 and 2)
$4,2 < f \leq 4,8$	-30 dBm	0 dBm (notes 1 and 2)
$4,8 < f \leq 6$	-30 dBm	-30 dBm
$6 < f \leq 8,5$	-13,3 dBm	0 dBm (notes 1 and 3)
$8,5 < f \leq 9$	-25 dBm	0 dBm (note 2)
$9 < f \leq 10,6$	-25 dBm	-25 dBm
$10,6 < f$	-45 dBm	-45 dBm

NOTE 1: Within the band 3,1 - 4,8 GHz and 6 - 8,5 GHz, devices implementing Low Duty Cycle (LDC) mitigation technique (see clause 4.8) are permitted to operate with a maximum mean e.i.r.p. spectral density of -41,3 dBm/MHz and a maximum peak e.i.r.p. of 0 dBm defined in 50 MHz. Operation is in addition subject to the implementation of an exterior limit (see clause 4.5) of -53,3 dBm/MHz.

NOTE 2: Within the bands 3,1 - 4,8 GHz and 8,5 - 9 GHz, devices implementing Detect And Avoid (DAA) mitigation technique (see clause 4.7) are permitted to operate with a maximum mean e.i.r.p. spectral density of -41,3 dBm/MHz and a maximum peak e.i.r.p. of 0 dBm defined in 50 MHz. Operation is in addition subject to the implementation of Transmit Power Control (TPC) mitigation technique (see clause 4.6) and an exterior limit (see clause 4.5) of -53,3 dBm/MHz.

NOTE 3: Within the band 6 - 8,5 GHz devices implementing Transmit Power Control (TPC) mitigation technique (see clause 4.6) and an exterior limit (see clause 4.5) of -53,3 dBm/MHz are permitted to operate with a maximum mean e.i.r.p. spectral density of -41,3 dBm/MHz and a maximum peak e.i.r.p. of 0 dBm defined in 50 MHz.

Table 2 is based upon CEPT 45 [i.13]. The EC/DEC on UWB [i.4] is currently under revision. The amended EC/DEC is expected within 2014.

The power reading on the spectrum analyser can be directly related to the peak power limit when a spectrum analyser resolution bandwidth of 50 MHz is used for the measurements. If a spectrum analyser resolution bandwidth of X MHz is used instead, the maximum peak power limit shall be scaled down by a factor of $20 \log(50/X)$, where X represents the measurement bandwidth used.

EXAMPLE: If the maximum peak power in a particular frequency band is 0 dBm/50 MHz, and a 3 MHz resolution bandwidth is used in case of an impulsive technology, then the measured value shall not exceed -24,4 dBm (see [1], clause A.3).

For rf carrier based modulation using multi-tone carriers and not having gating techniques implemented, the maximum peak power limit shall be scaled down by a different factor of $10 \log(50/X)$, where X represents the measurement bandwidth used.

4.3.4 Measurement uncertainty

The interpretation of the results for the measurements uncertainty shall be as given in TS 102 883 [1], clause 5.7, Table 1.

4.4 Receiver spurious emissions

4.4.1 Definition

Receiver spurious emissions are emissions at any frequency when the equipment is in receive mode. Consequently, receiver spurious emission testing applies only when the equipment can work in a receive-only mode.

4.4.2 Test procedure

The radiated test procedures as defined in clause 7.7 shall be used.

4.4.3 Limit

The narrowband spurious emissions of the receiver shall not exceed the values in Table 3 in the indicated bands (see CEPT/ERC/REC 74-01 [i.7]).

Table 3: Narrowband spurious emission limits for receivers

Frequency range	Limit
30 MHz to 1 GHz	-57 dBm (e.r.p.)
above 1 GHz to 40 GHz	-47 dBm (e.i.r.p.)

The above limit values apply to narrowband emissions, e.g. as caused by local oscillator leakage.

Wideband spurious emissions shall not exceed the values given in Table 4.

Table 4: Wideband spurious emission limits for receivers

Frequency range	Limit
30 MHz to 1 GHz	-47 dBm/MHz (e.r.p.)
Above 1 GHz to 40 GHz	-37 dBm/MHz (e.i.r.p.)

4.4.4 Measurement uncertainty

The interpretation of the results for the measurements uncertainty shall be as given in TS 102 883 [1], clause 5.7, Table 1.

4.5 Exterior Limit

4.5.1 Definition

The exterior limit is defined, for each UWB device installed in a road or rail vehicle, as the maximum mean e.i.r.p. spectral density for the emissions outside the vehicle at elevation angles higher than 0 degree [i.13]. The reference plane for the 0 degree is the sensor mounting height. Figure 1 shows the principle of these regulations.

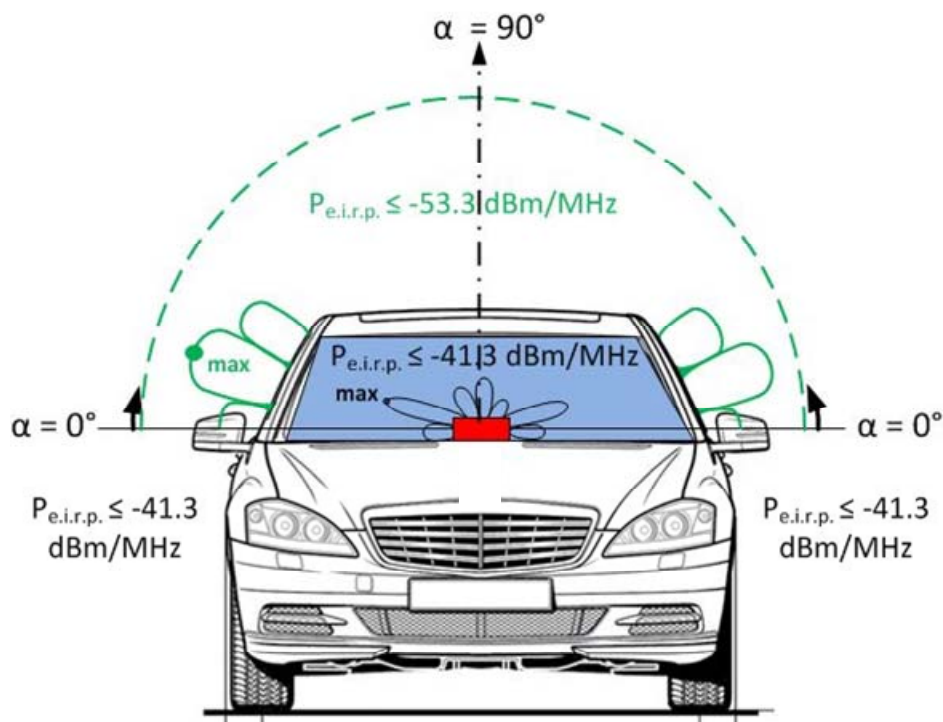

Figure 1: Principle of the regulations [i.13]

NOTE: The exterior limit refers to the maximum mean spectral density e.i.r.p. measured outside the vehicle and every local maximum should be below the limits.

4.5.2 Test Procedure

The test procedure shall be as defined in clauses 7.2 and 7.4.

4.5.3 Limit

Within the bands 3,1 GHz to 4,8 GHz, 6 GHz to 8,5 GHz and 8,5 GHz to 9 GHz, an exterior limit of -53,3 dBm/MHz applies, see Table 5.

Table 5: The exterior limit refers to the maximum mean spectral density e.i.r.p.

Frequency range [GHz]	Exterior limit $0^\circ < \alpha \leq 90^\circ$	Exterior limit $0^\circ \geq \alpha > -90^\circ$
$3,1 < f \leq 3,4$	-53,3 dBm/MHz	-41,3 dBm/MHz
$3,4 < f \leq 3,8$	-53,3 dBm/MHz	-41,3 dBm/MHz
$3,8 < f \leq 4,2$	-53,3 dBm/MHz	-41,3 dBm/MHz
$4,2 < f \leq 4,8$	-53,3 dBm/MHz	-41,3 dBm/MHz
$6 < f \leq 8,5$	-53,3 dBm/MHz	-41,3 dBm/MHz
$8,5 < f \leq 9$	-53,3 dBm/MHz	-41,3 dBm/MHz

4.5.4 Measurement uncertainty

The interpretation of the results for the measurements uncertainty shall be as given in TS 102 883 [1], clause 5.7, Table 1.

4.6 Transmit Power Control (TPC)

4.6.1 Definition

Transmit Power Control (TPC) is a mechanism to be used to ensure an interference mitigation on the aggregate power from a large number of radio devices. The TPC mechanism shall provide the full range from the highest to the lowest power level of the radio device.

4.6.2 Test procedure

The test procedure shall be as defined in TS 102 883 [1], clause 7.4.6.

4.6.3 Limit

Devices implementing TPC should fulfil at least a dynamic range of 12 dB (mean e.i.r.p. range of -41,3 to -53,3 dBm/MHz).

4.6.4 Measurement uncertainty

The interpretation of the results for the measurements uncertainty shall be as given in TS 102 883 [1], clause 5.7, Table 1.

4.7 Detect And Avoid (DAA)

4.7.1 Definition

Detect And Avoid (DAA) is a technology used to protect radio communication services by avoiding co channel operation.

Before transmitting, a system shall sense the channel within its operative bandwidth in order to detect the possible presence of other systems. If another system is detected, the first system shall avoid transmission until the detected system disappears [i.7].

4.7.2 Test procedure

DAA Test Procedure shall be done as given in TS 102 754 [2], Annex D.

4.7.3 Limit

Limits DAA parameters sets shall be as given in TS 102 754 [2], Annexes A to C.

4.7.4 Measurement Tolerance

Measurement tolerance for detection probabilities shall be as given in TS 102 754 [2], Annexes A to C.

4.8 Low Duty Cycle (LDC)

4.8.1 Definition

Duty Cycle is the defined as the cumulative transmitter on time over a defined period of time, which is the observation period.

4.8.2 Test procedure

The manufacturer shall provide sufficient information for determining compliance with the limits given in Table 6.

4.8.3 Limit

The base line limits for LDC are defined in [i.11] and shall be as shown in Table 6. The duty cycle consists of a long term duty cycle which relates to the limits per hour and short term parameters defined in ms or within one second.

Table 6: Baseline limits for low duty cycle

Parameter		Limit
Maximum transmitter on time	Ton max	5 ms
Mean transmitter off time	Toff mean	≥ 38 ms (averaged over 1 s)
Sum transmitter off time	∑ Toff	> 950 ms per second
Sum transmitter on time (Long term duty cycle)	∑ Ton	< 18 s per hour (see note)
NOTE: Within the band 3,4 GHz to 4,8 GHz, this requirement does not apply for operation with vehicle speed above 40 km/h. For vehicle speeds between 20 km/h and 40 km/h a gradual implementation of the long term duty cycle limit from 18 to 180 seconds per hour would be required as shown in Figure 2.		

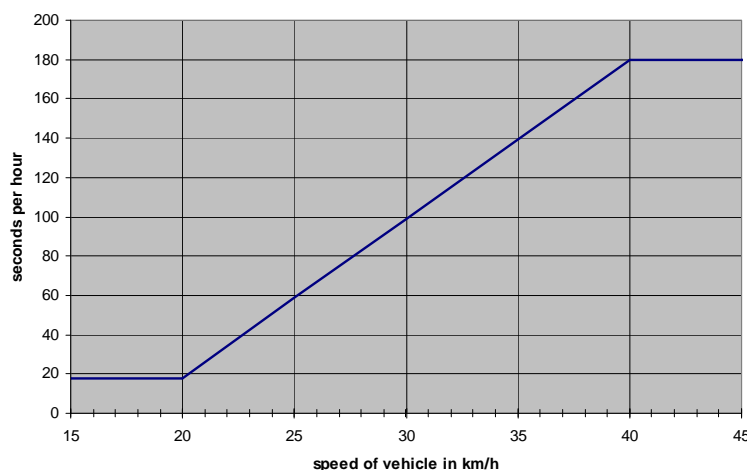

Figure 2: Long term duty cycle: Sum of transmitter on time with respect to speed of the vehicle [i.11]

4.9 Equivalent mitigation techniques

4.9.1 Other mitigation techniques and mitigation factors

Other mitigation techniques and mitigation factors can be taken into account for the calculation of the maximum allowed TX power of a UWB radio device as long as the reached mitigation factors are equivalent or higher than the mitigation factors reached using the presented techniques which have been accepted by the CEPT/ECC (e.g. ECC report 120 [i.3]).

EXAMPLE: Deployment of the radio device on a vehicle, which operates only in a restricted indoor area with higher wall attenuation, shielding or the deployment and installation of the UWB system in a controlled manner is an example of additional mitigation factors. The additional mitigation factors need to be weighed against the specific services to be protected and a similar approach has to be taken like e.g. in ECC report 120 [i.3].

The manufacturer shall provide compliance with the transmission emission limits in Table 1 and Table 2 when using equivalent mitigation techniques.

NOTE: Regulations in the EC decision 2007/131/EC [i.4] and its amendment allow for other equivalent mitigation techniques to be used across all frequency bands, where these offer at least equivalent protection to that provided by the limits in the decision.

4.9.2 Power vs. LDC Tradeoff Method

The allowed duty cycle can be increased by reducing the transmitted power, such that the average mean power remains unchanged. This kind of trading is described in Table 7. The bold row with grey background represents currently allowed baseline limits in ECC/DEC/(06)04 [i.11], and the other rows represent alternative trading ranges: if the mean power spectral density (PSD) is decreased, the parameter for the long term duty cycle and the short term duty cycle can be used according to the corresponding row.

Table 7: Parameter Specification for Power vs. LDC Tradeoff Method [i.13]

mean power spectral density limit (e.i.r.p.) [dBm/MHz]	Exterior limit (e.i.r.p.) [dBm/MHz]	Maximum transmitter on time T_{on} % in 1 second	T_{on} max [ms]	T_{off} mean [ms] (averaged over 1sec)	$\sum T_{on} / 1sec$ [ms]	$\sum T_{off} / 1sec$ [ms]	Long term LDC [sec in 1hr] (Note)
-41,3	-53,3	5	5	≥ 38	< 50	> 950	18 - 180
-44,3	-56,3	10	10	≥ 38	< 100	> 900	36 - 360
-47,3	-59,3	20	20	≥ 38	< 200	> 800	72 - 720
-50,3	-62,3	40	40	≥ 38	< 400	> 600	144 - 1 440
-51,3	-63,3	50	50	≥ 38	< 500	> 500	180 - 1 800

NOTE: Two values for the long term duty cycle are related to the fact that for vehicle speed range between 20 km/h and 40 km/h a gradual implementation of the long term duty cycle limit would be required, i.e.: as shown in Figure 2 for the baseline limit. Therefore the lower value is the limit at 20 Km/h, the higher value is the limit at 40 Km/h.

NOTE: In CEPT Report 45 [i.13] it has been agreed that the mitigation parameters reported in Table 7 give equivalent protection to the baseline LDC limits stated in Table 6.

5 Test Requirements

5.1 Product information

The following product information shall be provided by the manufacturer:

- relevant harmonized standard and environmental conditions of use/intended use;
- the type of UWB technology implemented in the equipment (e.g. carrier-based, impulse, modified impulse, etc.);
- the type of modulation schemes available (e.g. OFDM modulation, pulsed modulation like PPM or Pulse Polarity Modulation or any other type of modulation, etc.);
- for all modulation schemes the modulation parameters need to be provided: for example modulation period, deviation or dwell times within a modulation period (FH systems), rate of modulation (Hz/s), number of carrier for OFDM, modulation bandwidth;
- the operating frequency range(s) of the equipment (see clause 7);
- the type of the equipment (e.g. stand-alone equipment, plug-in radio device, combined equipment, etc.), (see also clause 5.5);
- the intended combination(s) of the radio equipment power settings and one or more antenna assemblies and their corresponding e.i.r.p. levels (see also clause 5.6);
- the nominal power supply voltages of the stand-alone radio equipment or the nominal power supply voltages of the host equipment or combined equipment in case of plug-in radio devices;

- the test modulation to be used for testing (see also clause 5.2);
- the inclusion and any necessary implementation details of features such as gating or hopping;
- the inclusion and any necessary implementation details of any mitigation or equivalent mitigation techniques;
- in case of conducted measurements, the antenna impedance as well as maximum antenna gain characteristics (frequency response) over the relevant frequency range covered in the related harmonized standard;
- the allowed orientation for the installation of the device.

5.2 Requirements for the test modulation

See TS 102 883 [1], clause 5.3.

5.3 Test conditions, power supply and ambient temperatures

See TS 102 883 [1], clause 5.4.

5.4 Choice of equipment for test suites

See TS 102 883 [1], clause 5.5.

5.4.1 Multiple Operating bandwidths and multiband equipment

Where equipment has more than one operating bandwidth (e.g. 500 MHz and 1 300 MHz), a minimum of two operating bandwidths shall be chosen such that the lower and higher limits of the operating range(s) of the equipment are covered (see clause 4.2). All operating bandwidths of the equipment shall be declared by the equipment manufacturer.

In case of multiband equipment (i.e. equipment that can operate with an operating bandwidth below 4,8 GHz and above 6,0 GHz), the lowest and highest channel in operation of each band shall be tested.

5.5 Testing of host connected equipment and plug-in radio devices

See TS 102 883 [1], clause 5.6.

5.6 Interpretation of the measurement results

The interpretation of the results for the measurements described in the present document shall be as follows:

- 1) the measured value related to the corresponding limit shall be used to decide whether equipment meets the requirements of the present document;
- 2) the measurement uncertainty value for the measurement of each parameter shall be recorded;
- 3) the recorded value of the measurement uncertainty shall be wherever possible, for each measurement, equal to or lower than the figures in Table 8, and the interpretation procedure specified in clauses 5.6.1 and 5.6.2 shall be used.

For the test methods, according to the present document, the measurement uncertainty figures shall be calculated in accordance with the guidance provided in TR 100 028 [3] and shall correspond to an expansion factor (coverage factor) $k = 1,96$ or $k = 2$ (which provide confidence levels of respectively 95 % and 95,45 % in the case where the distributions characterizing the actual measurement uncertainties are normal (Gaussian)).

Table 8 is based on such expansion factors.

Table 8: Maximum measurement uncertainty [1]

Parameter	Uncertainty
Radio Frequency	$\pm 1 \times 10^{-5}$
All emissions, radiated	± 6 dB (see note)
Conducted	± 3 dB
Temperature	± 1 °C
Humidity	± 5 %
DC and low frequency voltages	± 3 %
NOTE: For radiated emissions measurements below 2,7 GHz and above 10,6 GHz it may not be possible to reduce measurement uncertainty to the levels specified in Table 1 (due to the very low signal level limits and the consequent requirement for high levels of amplification across wide bandwidths). In these cases alone it is acceptable to employ the alternative interpretation procedure specified in clause 5.6.2.	

5.6.1 Measurement uncertainty is equal to or less than maximum acceptable uncertainty

The interpretation of the results when comparing measurement values with specification limits shall be as follows:

- a) When the measured value exceeds the limit value within the range of the measurement uncertainty the equipment under test meets the requirements of the present document.
- b) The measurement uncertainty calculated by the test technician carrying out the measurement shall be recorded in the test report.
- c) The measurement uncertainty calculated by the test technician may be a maximum value for a range of values of measurement, or may be the measurement uncertainty for the specific measurement undertaken. The method used shall be recorded in the test report.

5.6.2 Measurement uncertainty is greater than maximum acceptable uncertainty

The interpretation of the results when comparing measurement values with specification limits should be as follows:

- a) When the measured value plus the difference between the maximum acceptable measurement uncertainty and the measurement uncertainty calculated by the test technician does not exceed the limit value plus the maximum acceptable measurement uncertainty the equipment under test meets the requirements of the present document.
- b) When the measured value plus the difference between the maximum acceptable measurement uncertainty and the measurement uncertainty calculated by the test technician exceeds the limit value within the range of the measurement uncertainty the equipment under test does not meet the requirements of the present document.
- c) The measurement uncertainty calculated by the test technician carrying out the measurement shall be recorded in the test report.
- d) The measurement uncertainty calculated by the test technician may be a maximum value for a range of values of measurement, or may be the measurement uncertainty for the specific measurement undertaken. The method used shall be recorded in the test report.

5.7 Emissions

UWB transmitters emit very low power radio signals, comparable with the power of spurious emissions from digital and analogue circuitry. If it can be clearly demonstrated that an emission from the ultra-wideband radio device is not the ultra-wideband emission identified in clause 7.7 (e.g. by disabling the radio device's UWB transmitter or disconnecting and terminating, internally or externally the antenna of the device) or it can clearly be demonstrated that it is impossible to differentiate between other emissions and the UWB transmitter emissions, that emission or aggregated emissions shall be considered against the receiver spurious emissions limits defined in the relevant harmonized standard.

See TS 102 883 [1], clause 7.2.5.

6 Test setups and procedures

In this clause the general setup of a test bed for the test of UWB equipment will be described.

6.1 Introduction

See TS 102 883 [1], clause 6.1.

6.2 Initial Measurement steps

See TS 102 883 [1], clause 6.2.

6.3 Radiated measurements

6.3.1 General

See TS 102 883 [1], clause 6.3.1.

6.3.2 Test sites and general arrangements for measurements involving the use of radiated fields

See TS 102 883 [1], clause 6.3.2.

6.3.3 Guidance on the use of a radiation test site

See TS 102 883 [1], clause 6.3.3.

6.3.3.1 Range length

The range length for all these types of test facility should be adequate to allow for testing in the far field of the DUT i.e. it should be equal to or exceed:

$$\frac{2(d_1 + d_2)^2}{\lambda}$$

Where:

d_1 is the largest dimension of the DUT/dipole after substitution (m);

d_2 is the largest dimension of the test antenna (m);

λ is the test frequency wavelength (m).

It should be noted that in the substitution part of this measurement, where both test and substitution antennas are half wavelength dipoles, this minimum range length for far-field testing would be:

$$2\lambda$$

It should be noted in test reports when either of these conditions is not met so that the additional measurement uncertainty can be incorporated into the results.

NOTE 1: For the fully anechoic chamber, no part of the volume of the DUT should, at any angle of rotation of the turntable, fall outside the "quiet zone" of the chamber at the nominal frequency of the test.

NOTE 2: The "quiet zone" is a volume within the anechoic chamber (without a ground plane) in which a specified performance has either been proven by test, or is guaranteed by the designer/manufacturer. The specified performance is usually the reflectivity of the absorbing panels or a directly related parameter (e.g. signal uniformity in amplitude and phase). It should be noted however that the defining levels of the quiet zone tend to vary.

It is not necessary to measure the exterior limit at ranges larger than 3 m, because sufficient accuracy is achieved even for a whole car. Larger distances lead to sensitivity issues for the exterior limit, which need to be taken into account. More information about the impact of the distance on the measurement accuracy can be found in TR 103 086 [i.2].

6.3.4 Coupling of signals

See TS 102 883 [1], clause 6.3.4.

6.3.5 Standard test methods

Three test methods are defined for determining the radiated power of a radio device. Each method is further divided into two procedures for calibrated and not calibrated measurement setups.

6.3.5.1 Generic measurement method

6.3.5.1.1 Calibrated setup

The measurement receiver, test antenna and all associated equipment (e.g. cables, filters, amplifiers, etc.) shall have been recently calibrated against known standards at all the frequencies on which measurements of the equipment are to be made. A suggested calibration method is given in clause 6.3.6 and a specification of the measurement equipment is recommended in Annex B.

If an anechoic chamber with conductive ground plane is used, the ground shall be covered by absorbing material in the area of the direct ground reflection from the DUT to the test antenna.

On a test site according to clause 6.3, the equipment shall be placed at the specified height on a support, and in the position closest to normal use as declared by the provider. If the maximum of the antenna/transmission pattern is not known a full spherical scan according to clauses 6.3.5.2 or 6.3.5.3 shall be performed.

The test antenna shall be oriented initially for vertical polarization and shall be chosen to correspond to the frequency of the transmitter.

The output of the test antenna shall be connected to the spectrum analyser via whatever (fully characterized) equipment is required to render the signal measurable (e.g. amplifiers).

The transmitter shall be switched on, if possible without modulation, and the spectrum analyser shall be tuned to the frequency of the transmitter under test.

The test antenna shall be raised and lowered through the specified range of height until a maximum signal level is detected by the spectrum analyser.

The transmitter shall then be rotated through 360° in the horizontal plane, until the maximum signal level is detected by the spectrum analyser.

The test antenna shall be raised and lowered again through the specified range of height until a maximum signal level is detected by the spectrum analyser.

The test antenna should be rotated to horizontal polarization and the measurement procedure should be repeated.

The maximum signal level of vertical and horizontal orientated antenna detected by the spectrum analyser shall be noted and converted into the radiated power by application of the pre-determined calibration coefficients for the equipment configuration used.

6.3.5.1.2 Substitution method

On a test site, selected from clause 6.3.2, the equipment shall be placed at the specified height on a support, as specified in clause 6.3.2, and in the position closest to normal use as declared by the provider. If the maximum of the antenna/transmission pattern is not known a full spherical scan according to clauses 6.3.5.2 or 6.3.5.3 shall be performed.

The test antenna shall be oriented initially for vertical polarization and shall be chosen to correspond to the frequency of the transmitter.

The output of the test antenna shall be connected to the spectrum analyser.

The transmitter shall be switched on, if possible without modulation, and the measuring receiver shall be tuned to the frequency of the transmitter under test.

The test antenna shall be raised and lowered through the specified range of height until a maximum signal level is detected by the spectrum analyser.

The transmitter shall then be rotated through 360° in the horizontal plane, until the maximum signal level is detected by the spectrum analyser.

The test antenna shall be raised and lowered again through the specified range of height until a maximum signal level is detected by the spectrum analyser.

The maximum signal level detected by the spectrum analyser shall be noted.

The transmitter shall be replaced by a substitution antenna as defined in clause 6.3.2.4 in [1].

The substitution antenna shall be orientated for vertical polarization. The substitution antenna shall be connected to a calibrated signal generator.

If necessary, the input attenuator setting of the spectrum analyser shall be adjusted in order to increase the sensitivity of the spectrum analyser.

The test antenna shall be raised and lowered through the specified range of height to ensure that the maximum signal is received. When a test site according clause 6.3.2.1 in [1] is used, the height of the antenna shall not be varied.

The input signal to the substitution antenna shall be adjusted to the level that produces a level detected by the spectrum analyser, that is equal to the level noted while the transmitter radiated power was measured, corrected for the change of input attenuator setting of the spectrum analyser.

The input level to the substitution antenna shall be recorded as power level, corrected for any change of input attenuator setting of the spectrum analyser.

The measurement shall be repeated with the test antenna and the substitution antenna orientated for horizontal polarization.

The measure of the radiated power of the radio device is the larger of the two levels recorded at the input to the substitution antenna, corrected for gain of the substitution antenna if necessary.

6.3.5.2 Spherical scan with automatic test antenna placement

Figure 3 shows the spherical measurement method using automatic test antenna placement. The RX antenna is moveable and it is mounted for example on an automatic arm, which moves the antenna stepwise on a sphere around the DUT.

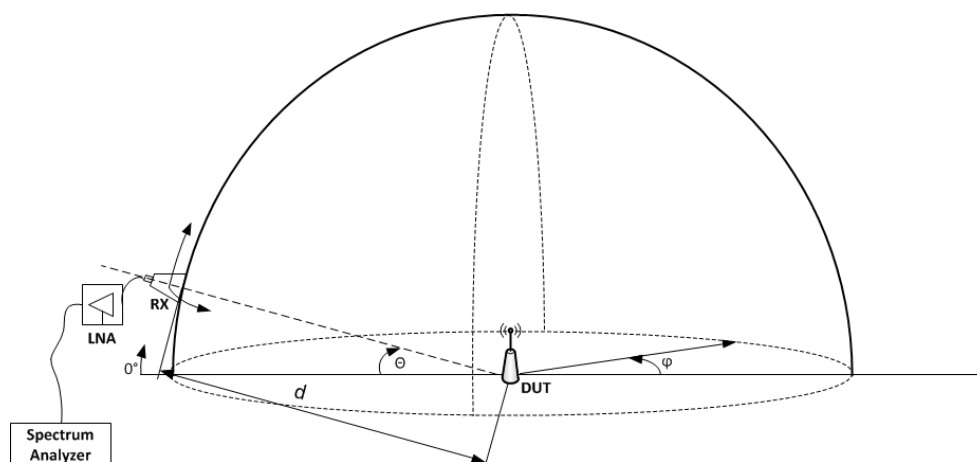

Figure 3: Spherical scan setup using automatic test antenna placement

The maximum measurement step size for the azimuth angle φ and for the elevation angle Θ is smaller or equal to 5° . In a half sphere scan φ is varied from 0 to 360° and Θ is changed from 0 to 90° . Therefore the DUT has to be mounted according to the typical usage in the application. If a full sphere scan shall be performed, then the device can be tilted by 180° and the half sphere shall be measured again. The scan shall be performed at a distance given by clause 6.3.3.1.

Another relation of the angles is possible, but the coverage of the relevant partial spheres shall be ensured.

6.3.5.2.1 Calibrated setup

The measurement receiver, test antenna and all associated equipment (e.g. cables, filters, amplifiers, etc.) shall have been recently calibrated against known standards at all the frequencies on which measurements of the equipment are to be made. A suggested calibration method is given in clause 6.3.6 and a specification of the measurement equipment is recommended in Annex B.

If an anechoic chamber with conductive ground plane is used, the ground shall be covered by absorbing material in the area of the direct ground reflection from the DUT to the test antenna. If the device is mounted below the car, the measurements shall be done on a non-metalized ground, therefore e.g. absorbing or realistic ground material shall cover the area of the sensor and direct reflections (see [i.1]).

The equipment shall be placed in an anechoic chamber (compare clauses 6.3.2.1 and 6.3.2.2 in [1]), which allows the spherical scan. The DUT shall be placed closest to the orientation of normal operation.

The test antenna shall be oriented initially for vertical polarization and shall be chosen to correspond to the frequency of the transmitter.

The output of the test antenna shall be connected to the spectrum analyser via whatever (fully characterized) equipment is required to render the signal measurable (e.g. amplifiers).

The transmitter shall be switched on, if possible without modulation, and the spectrum analyser shall be tuned to the frequency of the transmitter under test.

The RX antenna shall be moved stepwise on the sphere and in each location the signal level shall be noted.

After all locations have been reached, the measurement procedure shall be repeated for horizontal polarized test antenna orientation.

The maximum signal level, measured by horizontal and vertical orientated antenna, detected by the spectrum analyser shall be noted and converted into the radiated power by application of the pre-determined calibration coefficients for the equipment configuration used.

6.3.5.2.2 Substitution method

The equipment shall be placed in an anechoic chamber, which allows the spherical scan (compare clauses 6.3.2.1 and 6.3.2.2 in [1]). The DUT shall be placed closest to the orientation of normal operation.

If an anechoic chamber with conductive ground plane is used, the ground shall be covered by absorbing material in the area of the direct ground reflection from the DUT to the test antenna. If the device is mounted below the car, the measurements shall be done on a non-metalized ground, therefore e.g. absorbing or realistic ground material shall cover the area of the sensor and direct reflections (see [i.1]).

The test antenna shall be oriented initially for vertical polarization and shall be chosen to correspond to the frequency of the transmitter.

The output of the test antenna shall be connected to the spectrum analyser.

The transmitter shall be switched on, if possible without modulation, and the measuring receiver shall be tuned to the frequency of the transmitter under test.

The RX antenna shall be moved stepwise on the sphere and in each location the signal level and its coordinates shall be noted.

After all locations have been reached, the maximum signal level and its coordinates shall be determined.

The transmitter shall be replaced by a substitution antenna as defined in clause 6.3.2.4 in [1].

The substitution antenna shall be orientated for vertical polarization.

The substitution antenna shall be connected to a calibrated signal generator.

If necessary, the input attenuator setting of the spectrum analyser shall be adjusted in order to increase the sensitivity of the spectrum analyser.

If an anechoic chamber with a conductive ground plane is used, then the substitution antenna shall be moved to the position of the previous maximum. The test antenna shall be moved around this position within a radius of at least five times the wavelength of the center frequency on the sphere to find the local maximum.

The input signal to the substitution antenna shall be adjusted to the level that produces a level detected by the spectrum analyser, that is equal to the level noted while the transmitter radiated power was measured, corrected for the change of input attenuator setting of the spectrum analyser.

The input level to the substitution antenna shall be recorded as power level, corrected for any change of input attenuator setting of the spectrum analyser.

The measurement shall be repeated with the test antenna and the substitution antenna orientated for horizontal polarization.

The measure of the radiated power of the radio device is the larger of the two levels recorded at the input to the substitution antenna, corrected for the gain of the substitution antenna if necessary.

6.3.5.3 Spherical scan with rotating and tilting the DUT

Instead of using an automatic arm, it is also possible to rotate and tilt the DUT (see Figure 4). Thus, the same sphere can be measured as with the automatic arm. In contrast to the previous method Θ is changed from 0° to -90° for the half sphere measurement. The distance d is given by clause 6.3.3.1.

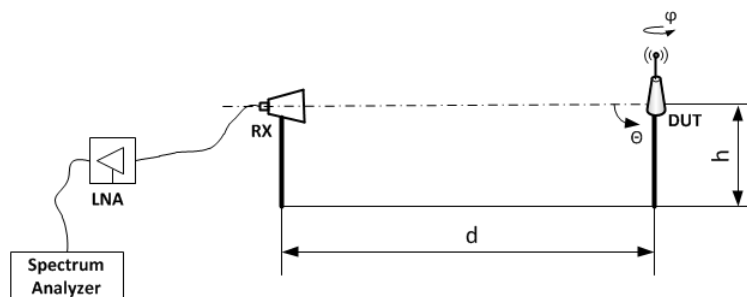

Figure 4: Spherical scan setup with rotation and tilt of the DUT

6.3.5.3.1 Calibrated setup

The measurement receiver, test antenna and all associated equipment (e.g. cables, filters, amplifiers, etc.) shall have been recently calibrated against known standards at all the frequencies on which measurements of the equipment are to be made. A suggested calibration method is given in clause 6.3.6 and a specification of the measurement equipment is recommended in Annex B.

If an anechoic chamber with conductive ground plane is used, the ground shall be covered by absorbing material in the area of the direct ground reflection from the DUT to the test antenna.

The equipment shall be placed in an anechoic chamber (compare clauses 6.3.2.1 and 6.3.2.2 in [1]), which allows the rotation and tilt of the DUT. The DUT shall be placed closest to the orientation of normal operation.

The test antenna shall be oriented initially for vertical polarization and shall be chosen to correspond to the frequency of the transmitter.

The output of the test antenna shall be connected to the spectrum analyser via whatever (fully characterized) equipment is required to render the signal measurable (e.g. amplifiers).

The transmitter shall be switched on, if possible without modulation, and the spectrum analyser shall be tuned to the frequency of the transmitter under test.

The TX antenna shall be stepwise rotated and tilted that the sphere of interest is covered. The signal level shall be noted in each location.

After all locations have been reached, the measurement procedure shall be repeated for horizontal polarized test antenna orientation.

The maximum signal level detected by the spectrum analyser shall be determined and converted into the radiated power by application of the pre-determined calibration coefficients for the equipment configuration used.

6.3.5.3.2 Substitution method

The equipment shall be placed in an anechoic chamber, which allows the rotation and tilt of the DUT. The DUT shall be placed closest to the orientation of normal operation.

The test antenna shall be oriented initially for vertical polarization and shall be chosen to correspond to the frequency of the transmitter.

The output of the test antenna shall be connected to the spectrum analyser.

The transmitter shall be switched on, if possible without modulation, and the measuring receiver shall be tuned to the frequency of the transmitter under test.

The TX antenna shall be stepwise rotated and tilted that the sphere of interest is covered. The signal level shall be noted in each orientation.

After all locations have been reached, the maximum signal level and the orientation of the DUT shall be noted.

The transmitter shall be replaced by a substitution antenna as defined in clause 6.3.2.4 in [1].

The substitution antenna shall be orientated for vertical polarization and the length of the substitution antenna shall be adjusted to correspond to the frequency of the transmitter.

The substitution antenna shall be connected to a calibrated signal generator.

If necessary, the input attenuator setting of the spectrum analyser shall be adjusted in order to increase the sensitivity of the spectrum analyser.

If an anechoic chamber with a conductive ground plane is used, then the test antenna shall be raised and lowered through the specified range of height that the maximum signal level is received.

The input signal to the substitution antenna shall be adjusted to the level that produces a level detected by the spectrum analyser, that is equal to the level noted while the transmitter radiated power was measured, corrected for the change of input attenuator setting of the spectrum analyser.

The input level to the substitution antenna shall be recorded as power level, corrected for any change of input attenuator setting of the spectrum analyser.

The measurement shall be repeated with the test antenna and the substitution antenna orientated for horizontal polarization.

The measure of the radiated power of the radio device is the larger of the two levels recorded at the input to the substitution antenna, corrected for gain of the substitution antenna if necessary.

6.3.5.4 Spherical scan other methods

Other methods for spherical scans are allowed but it has to be ensured that the relevant sphere is full covered. Then again the calibrated or substitution method shall be applied. The exact method for the scanning shall be described in the measurement report.

6.3.6 Standard calibration method

See TS 102 883 [1], clause 6.3.6.

6.4 Conducted measurements

See TS 102 883 [1], clause 6.4.

7 Test procedures for essential radio test suites

7.1 General

First the complete signal device shall be measured for:

- the maximum mean power spectral density (e.i.r.p.);
- the maximum peak power (e.i.r.p.);
- the operating bandwidth(s);
- the receiver spurious emissions;
- Other emissions (OE);
- Power control;
- Detect and avoid Exterior limit.

7.2 Test Procedure

The structure of the measurement procedure is shown in Figure 5.

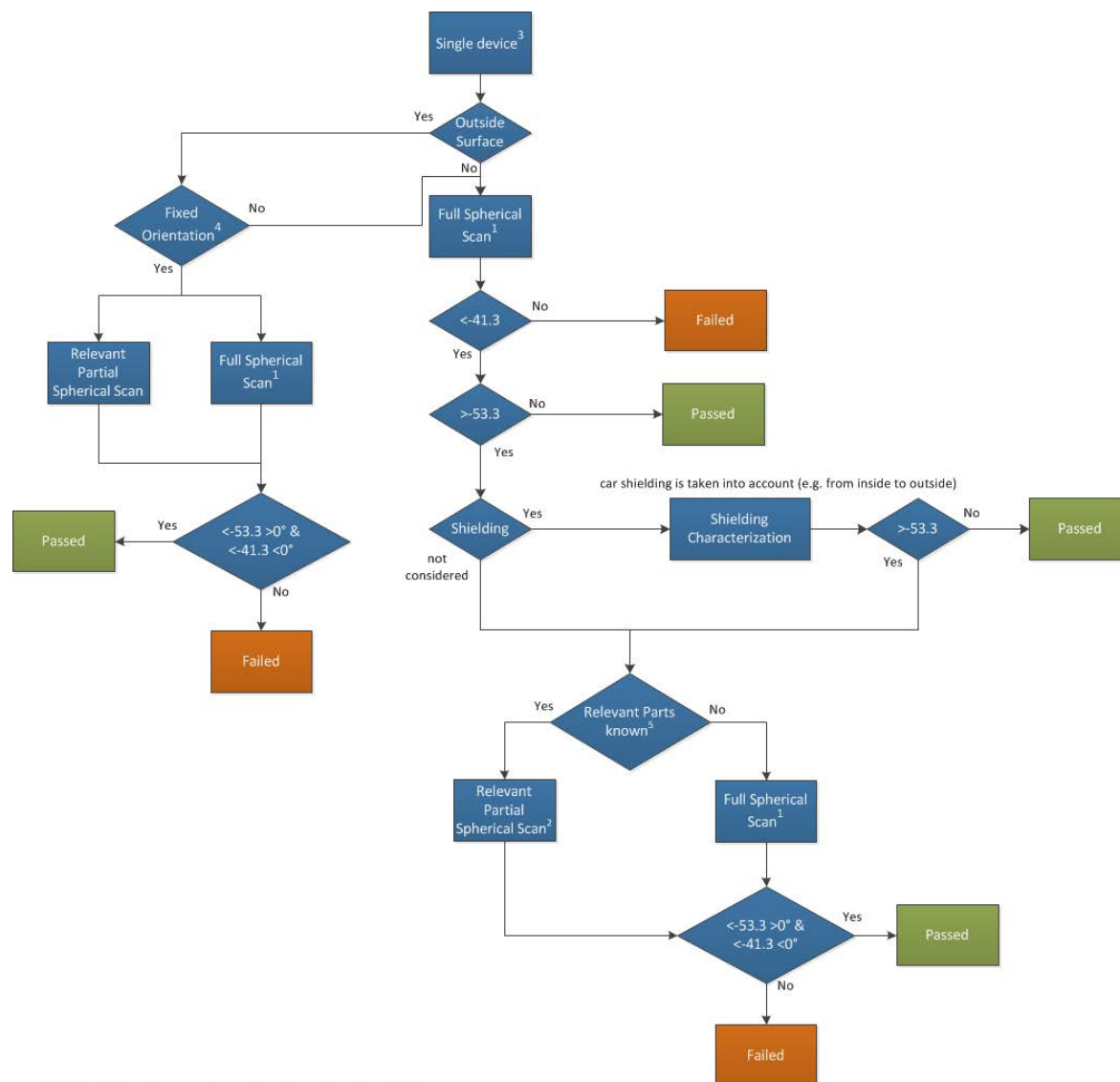

NOTE 1: Full spherical scan to obtain transmission pattern or common measurement method according to TS 102 883 [1].

NOTE 2: The horizontal reference plane is the height of the sensor and all measurements have to be performed above 0° elevation to this plane.

NOTE 3: If the part of mounting has influence on the transmission pattern, then the manufacturer can declare the whole part as a device, e.g. door, mirror, bonnet, light, etc.

NOTE 4: If the fixed orientation of the surface and therefore the main transmission direction can be declared by the manufacturer.

NOTE 5: Are the relevant parts of the vehicle, which are expected to influence the transmission to the outside. The measurement setup can be reduced to the known relevant parts.

Figure 5: Concept for the measurement procedure of the exterior limit

The device under test (DUT) is specifically measured for different applications and mounting locations.

If a device has a maximum mean power spectral density (e.i.r.p) of less or equal than -53,3 dBm/MHz including the transmission pattern, then it is only necessary to measure the device by itself. This can be done radiated or conducted according to TS 102 883 [1]. If the transmission pattern of the device is not known a full spherical scan according to clause 6.3.5.2 and Annex B shall be performed.

If the maximum mean power is greater than $-53,3$ dBm/MHz (e.i.r.p.) and no shielding to the outside of the car occurs or the shielding is not considered, then the device has to be measured with the relevant parts of the car, which influence the transmission pattern. When the relevant parts are known, then the device can be measured with these only and if applicable for a relevant area, e.g. see tire applications in Annex C. These parts and the relevant area have to be declared by the manufacturer and should be included in the measurement report.

If shielding from the inside to the outside of the car occurs, it can be taken into account if the manufacturer can characterize the lowest shielding in all direction to the outside. An example for a measurement procedure for the shielding characterization can be found in [i.1]. If the transmit power (e.i.r.p.) minus the shielding is less than $-53,3$ dBm/MHz the device passes, otherwise the device shall be measured with the relevant parts of the car.

If the device is mounted outside on the surface of the car and the mounting orientation is known the spherical scan may be reduced to the relevant area, e.g. if the device is mounted on a door the spherical scan can be limited to the area in front of the door (see Annex C). The orientation of the device shall be included in the product information (see clause 5.1). If more than one orientation for the transmission is possible, the measurement analysis shall take them into account.

If the dimension of the vehicle, e.g. Truck or Train, is in such dimension that a spherical scan around the DUT cannot be performed, based on the mechanical dimensions of the measurement equipment and the vehicle, the measurement shall be limited to the spherical sector where it can be performed, see Figure 6. The test antenna should be at least $0,5$ m away from the surface of the vehicle. If the dimension of vehicle is in such a mechanical dimension that this can also not realized, the vehicle part can be limited to the relevant mechanical parts of the vehicle, see Annex C as an example.

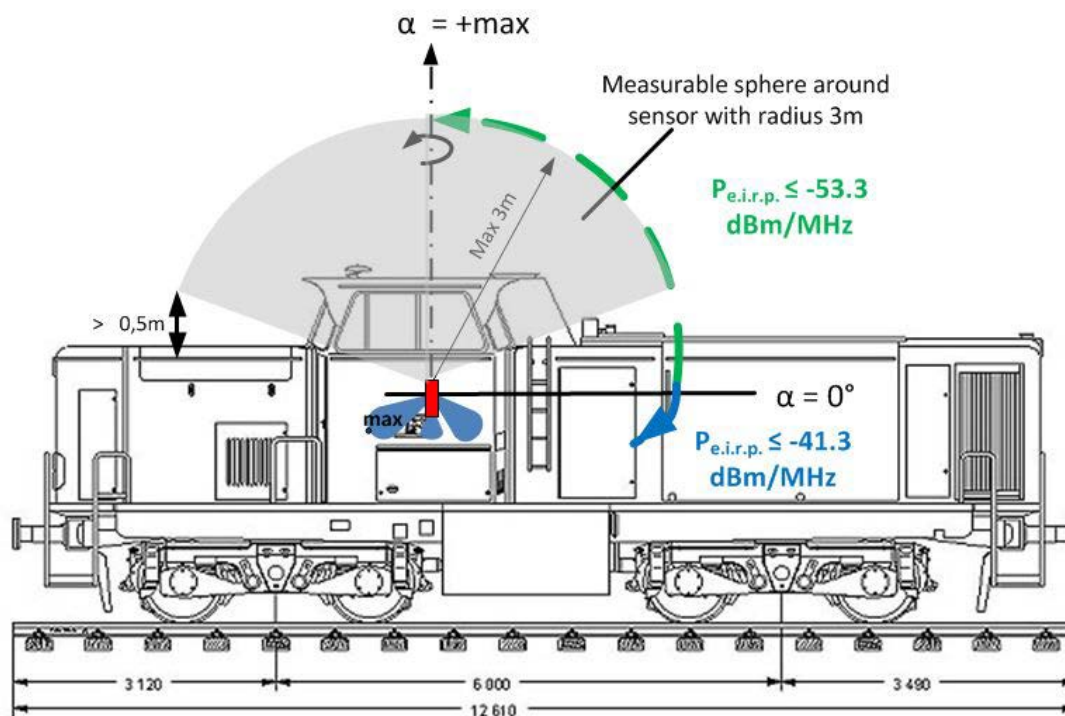

Figure 6: Example for an measurement spherical sector around an huge vehicle

The following methods of measurement shall apply to the testing of stand-alone units and to the equipment configurations identified in clause 5.5.

7.3 Method of measurements of the Ultra Wideband Emissions

Method of measurements of the Ultra Wideband Emissions shall be as given in TS 102 883 [1], clause 7.3.

7.4 Mean power spectral density measurements

Mean power spectral density measurements shall be as given in TS 102 883 [1], clause 7.4.3.

7.5 Peak power spectral density measurements

Peak power spectral density measurements shall be as given in TS 102 883 [1], clause 7.4.4.

7.6 Operating bandwidth

Operating bandwidth measurements shall be performed as given in TS 102 883 [1], clause 7.4.2.

7.7 Receiver spurious emissions

Receiver spurious emissions measurements shall be as given in TS 102 883 [1], clause 7.4.5.

7.8 Transmitter Power Control

Transmitter Power Control measurements shall be as given in TS 102 883 [1], clause 7.4.6.

7.9 Low Duty Cycle

Low Duty Cycle shall be as given in clause 4.8.2. of the present document.

7.10 Detect and Avoid Mechanisms

Test Procedures for Detect and Avoid Mechanisms shall be as given in TS 102 754 [2], Annex D.

7.11 Exterior Limit

The exterior limit shall be verified according to clauses 7.2 and 7.4.

Annex A (normative): HS Requirements and conformance Test specifications Table (HS-RTT)

The HS Requirements and conformance Test specifications Table (HS-RTT) in Table A.1 serves a number of purposes, as follows:

- it provides a statement of all the requirements in words and by cross reference to (a) specific clause(s) in the present document or to (a) specific clause(s) in (a) specific referenced document(s);
- it provides a statement of all the test procedures corresponding to those requirements by cross reference to (a) specific clause(s) in the present document or to (a) specific clause(s) in (a) specific referenced document(s);
- it qualifies each requirement to be either:
 - Unconditional: meaning that the requirement applies in all circumstances; or
 - Conditional: meaning that the requirement is dependent on the manufacturer having chosen to support optional functionality defined within the schedule.
- in the case of Conditional requirements, it associates the requirement with the particular optional service or functionality;
- it qualifies each test procedure to be either:
 - Essential: meaning that it is included with the Essential Radio Test Suite and therefore the requirement shall be demonstrated to be met in accordance with the referenced procedures;
 - Other: meaning that the test procedure is illustrative but other means of demonstrating compliance with the requirement are permitted.

Table A.1: HS Requirements and conformance Test specifications Table (HS-RTT)

Harmonized Standard EN 302 065-3						
The following requirements and test specifications are relevant to the presumption of conformity under the article 3.2 of the R&TTE Directive [i.10]						
Requirement			Requirement Conditionality		Test specification	
No	Description	Reference: clause No	U/C	Condition	E/O	Reference: clause No
1	Operating bandwidth	4.1	U		E	7.6
2	Maximum value of mean power spectral density	4.2	U		E	7.4
3	Maximum value of peak power	4.3	U		E	7.5
4	Exterior limit	4.5	U		E	7.11
5	Transmit Power Control	4.6	C	Applies only to equipment having TPC implemented	E	7.8
6	Receiver spurious emissions	4.4	C	Applies only to equipment that can be operated in a receive-only mode	E	7.7
7a	Detect-and-avoid	4.7	C	Applies only to equipment operating in the frequency band 3,1 GHz to 4,8 GHz and having DAA	E	7.10
7b	Detect-and-avoid	4.7	C	Applies only to equipment operating in the frequency band 8,5 GHz to 9 GHz and having DAA	E	7.10

Harmonized Standard EN 302 065-3						
The following requirements and test specifications are relevant to the presumption of conformity under the article 3.2 of the R&TTE Directive [i.10]						
Requirement			Requirement Conditionality		Test specification	
No	Description	Reference: clause No	U/C	Condition	E/O	Reference: clause No
8	Low Duty Cycle	4.8	C	Frequency range 3,1 GHz to 4,8 GHz: Mitigation requirements: (DAA-1 + DAA-2 + TPC) OR LDC (latter option, it is not mandatory to implement the whole range) Frequency range 6 GHz to 8,5 GHz: LDC is alternative to TPC Frequency range 8,5 GHz to 9 GHz: (DAA-3 + TPC) OR (DAA-3 + LDC)	E	7.9
9	Equivalent Mitigation Techniques	4.9	C	Applies only to equipment using equivalent mitigation techniques	X	

Key to columns:**Requirement:**

No A unique identifier for one row of the table which may be used to identify a requirement or its test specification.

Description A textual reference to the requirement.

Clause Number Identification of clause(s) defining the requirement in the present document unless another document is referenced explicitly.

Requirement Conditionality:

U/C Indicates whether the requirement is to be *unconditionally* applicable (U) or is *conditional* upon the manufacturers claimed functionality of the equipment (C).

Condition Explains the conditions when the requirement shall or shall not be applicable for a technical requirement which is classified "conditional".

Test Specification:

E/O Indicates whether the test specification forms part of the Essential Radio Test Suite (E) or whether it is one of the Other Test Suite (O).

NOTE: All tests whether "E" or "O" are relevant to the requirements. Rows designated "E" collectively make up the Essential Radio Test Suite; those designated "O" make up the Other Test Suite; for those designated "X" there is no test specified corresponding to the requirement. The completion of all tests classified "E" as specified with satisfactory outcomes is a necessary condition for a presumption of conformity. Compliance with requirements associated with tests classified "O" or "X" is a necessary condition for presumption of conformity, although conformance with the requirement may be claimed by an equivalent test or by manufacturer's assertion supported by appropriate entries in the technical construction file.

Clause Number Identification of clause(s) defining the test specification in the present document unless another document is referenced explicitly. Where no test is specified (that is, where the previous field is "X") this field remains blank.

Annex B (informative): Measurement antenna, preamplifier, and cable specifications

The radiated measurements set-up in Annex B specifies the use of a horn antenna and a wide-band high gain preamplifier above 1 GHz in order to measure the very low radiated power density level from UWB equipment.

Table B.1 gives examples of recommended data and features for the horn antenna and preamplifier to be used for the test set-up.

Table B.1: Recommended Hardware

Device	Parameter	Value
Preamplifier LNA	Bandwidth	< 1 GHz to > 15 GHz
	NF	< 2,5 dB
	Gain	> 30 dB
	Gain flatness across band	± 1,5 dB
	VSWR in/out across band	< 2:1
	Nominal impedance	50 Ω
RX Horn Antenna	3 dB bandwidth	< 1 GHz to > 15 GHz
	VSWR across band	< 1,5:1
	Gain (10 GHz)	> 16 dBi
	Gain (8 GHz)	> 14 dBi
	Gain (6 GHz)	> 12,5 dBi
	Gain (2 - 5 GHz)	> 10 dBi
Cable	Nominal impedance	50 Ω
	VSWR	< 1,2:1
	Shielding	> 60 dB
	Losses	Take losses into account for total gain calculations
NOTE:	The noise floor of the combined equipment should be at least 6 dB, but 10 dB would be optimal (see [i.1]).	

Annex C (informative): Surface mounted devices example mirror

Figure C.1 shows the measurement flow for the surface mounted devices.

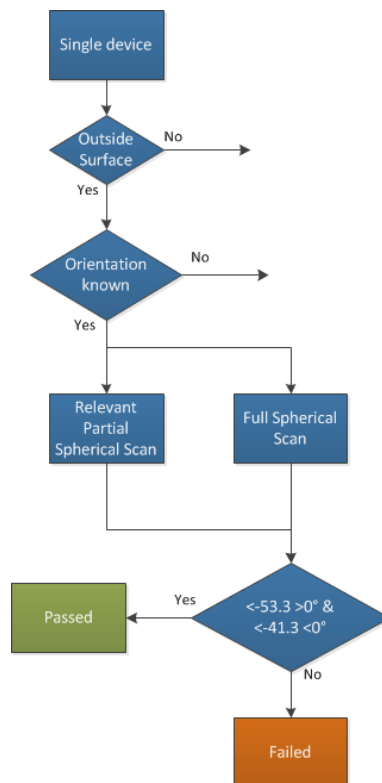

Figure C.1: Measurement Flow

The device inclusive antenna is installed within the mirror, because the mirror influences the transmission pattern of the device.

Usually the orientation of the mirror for the transmission is known and this operating orientation should be included in the product information (see clause 5.1). If the mirror transmits at different positions all positions have to be taken into account.

Usually a mirror does not have complete shielding in one direction a full spherical scan should be performed. If the relevant area can be reduced to a partial sphere, this should be declared by the manufacturer in the test report and only these sphere needs to be measured. An example is if the device is mounted on a door, then the backside of the door is not necessary to measure as the signals are not able to penetrate the metal of the door.

Figure C.2 shows the full spherical scan of the mirror according to clause 6.3.5.3. In this setup the mirror is rotating and tilting in a way that the full sphere is covered, while the test antenna is fixed. The calibrated or the substituted measurement method should be applied. After all measurements have been taken, the upper and the lower sphere should be analyzed (see Figure C.3). The reference plane is placed according to the orientation in the application. All e.i.r.p. peaks of the upper sphere should be lower or equal than -53,3 dBm/MHz and all e.i.r.p. peaks below should be smaller or equal to -41,3 dBm/MHz. If this is given the device passes the test otherwise it fails.

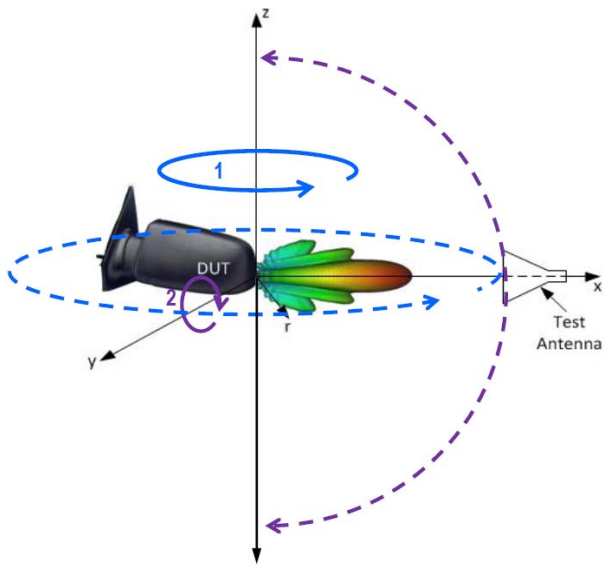

Figure C.2: Full spherical scan of a mirror

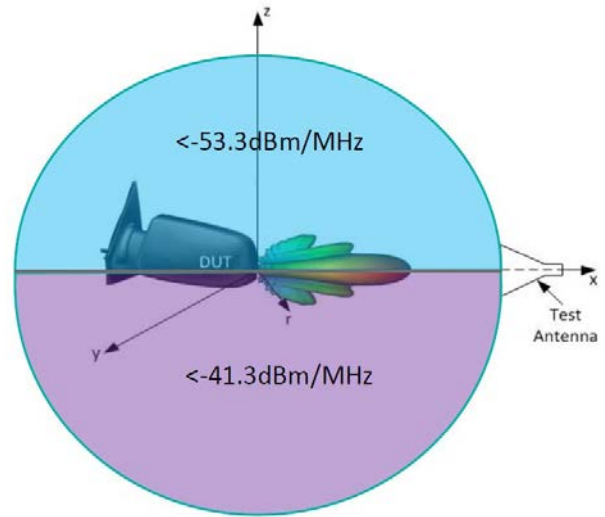

Figure C.3: Analysis of the limits

Annex D (normative): Device mounted inside the tyre

Figure D.1 shows the measurement flow for the device mounted inside the tyre (DUT). The measurement methods are defined in clause 6.3.5. For DUT the horizontal reference plane is the height of the sensor inside the tyre and all measurements have to be performed above 0° elevation with respect to this plane.

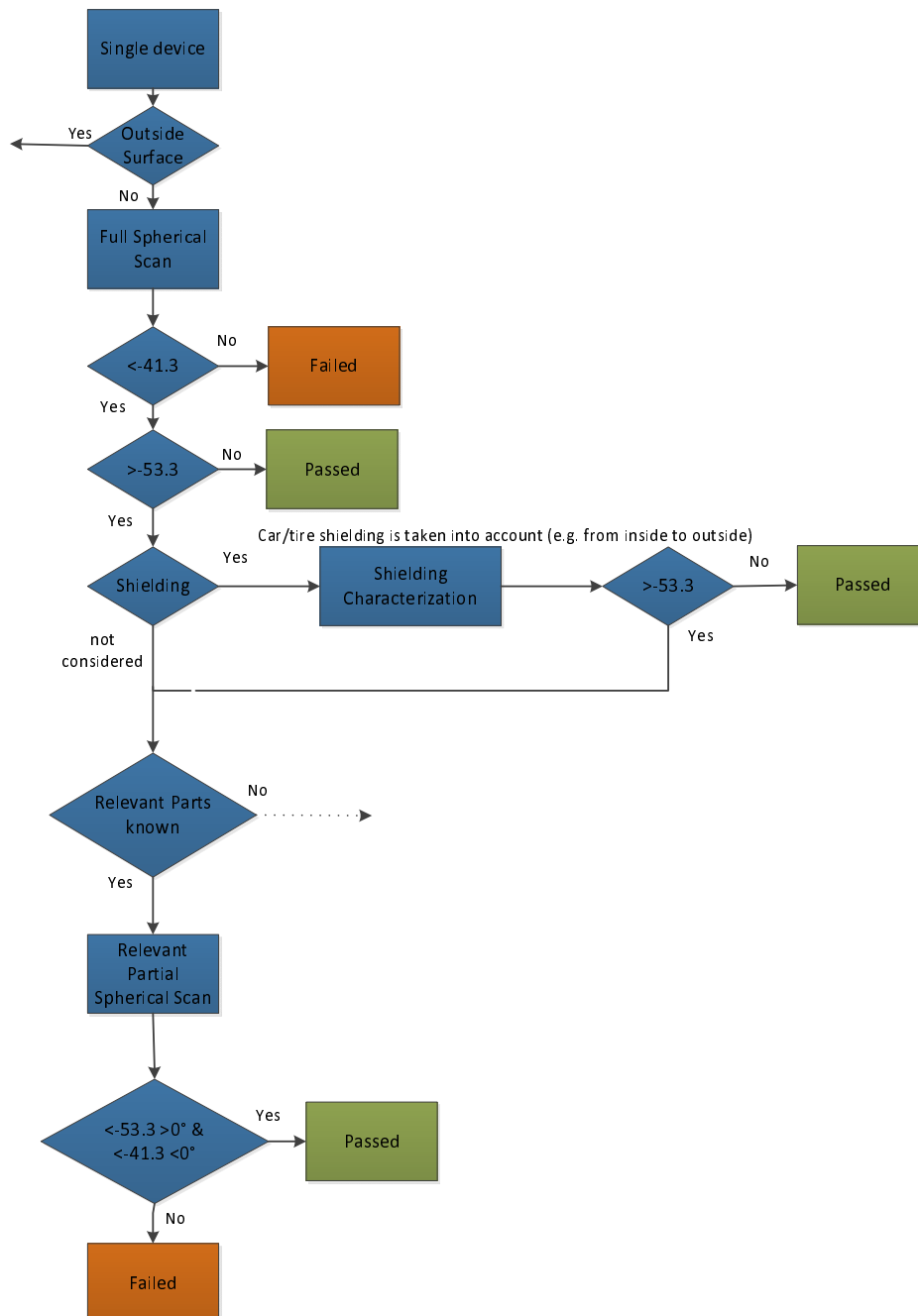

Figure D.1: Measurement Flow (DUT)

The device including the antenna is installed inside the tyre. Although it is mounted outside the metal surface of the vehicle, it cannot be considered outside of its surface. Therefore, the answer to the initial conditional block is negative.

Thus it is necessary to perform a total spherical scan around the device itself. In the case in which the result of the measurement is between -53,3 dBm/MHz and -41,3 dBm/MHz, the shielding characterization of the tyre can be taken into account. The device can be assumed to be compliant if the previously measured PSD level (standalone device) subtracted by the attenuation due to shielding effects of the tyre is smaller than or equal to -53,3 dBm/MHz. The minimum attenuation of the appropriate tyre family as declared by the tyre manufacturer shall be used in the calculation.

NOTE 1: Attenuation due to shielding effects of the tyre is related to the whole wheel including tyre with rim mounted on it.

NOTE 2: A method for the characterization of the attenuation/shielding can be found in Annex C of TR 103 086 [i.2].

If the attenuation due to shielding effects of the tyre is not applicable or sufficient, a partial spherical scan on a realistic ground shall be performed. For the scan the appropriate area in front of the wheel using the representative parts of the vehicle with the equipped tyre shall be used. The limits shall be verified for each 45° of the wheel rotation in the transmission angle.

NOTE 3: A proposal for a measurement setup with a planar scanner and the definition of relevant area/parts is given in TR 103 086 [i.2], Annex C.

Annex E (informative): Bibliography

- ETSI TS 102 902: "Electromagnetic compatibility and radio spectrum matters (ERM); Methods, parameters and test procedures for cognitive interference mitigation towards ER-GSM for use by UHF RFID using Detect-And-Avoid (DAA) or other similar techniques".

History

Document history			
V1.1.1	June 2013	EN Approval Procedure	AP 20131015: 2013-06-17 to 2013-10-15
V1.1.1	February 2014	Vote	V 20140408: 2014-02-07 to 2014-04-08