

# ETSI EN 301 908-17 V4.2.1 (2010-03)

---

*Harmonized European Standard (Telecommunications series)*

**Electromagnetic compatibility  
and Radio spectrum Matters (ERM);  
Base Stations (BS), Repeaters and User Equipment (UE)  
for IMT-2000 Third-Generation cellular networks;  
Part 17: Harmonized EN for IMT-2000,  
Evolved CDMA Multi-Carrier Ultra Mobile Broadband (UMB) (BS)  
covering the essential requirements  
of article 3.2 of the R&TTE Directive**

---



---

Reference

DEN/ERM-TFES-002-17

---

Keywords

3G, 3GPP2, cdma2000, cellular, digital, IMT-2000, mobile, radio, regulation, UMTS

**ETSI**

650 Route des Lucioles  
F-06921 Sophia Antipolis Cedex - FRANCE

Tel.: +33 4 92 94 42 00 Fax: +33 4 93 65 47 16

Siret N° 348 623 562 00017 - NAF 742 C  
Association à but non lucratif enregistrée à la  
Sous-Préfecture de Grasse (06) N° 7803/88

---

**Important notice**

Individual copies of the present document can be downloaded from:

<http://www.etsi.org>

The present document may be made available in more than one electronic version or in print. In any case of existing or perceived difference in contents between such versions, the reference version is the Portable Document Format (PDF). In case of dispute, the reference shall be the printing on ETSI printers of the PDF version kept on a specific network drive within ETSI Secretariat.

Users of the present document should be aware that the document may be subject to revision or change of status. Information on the current status of this and other ETSI documents is available at

<http://portal.etsi.org/tb/status/status.asp>

If you find errors in the present document, please send your comment to one of the following services:

[http://portal.etsi.org/chaicor/ETSI\\_support.asp](http://portal.etsi.org/chaicor/ETSI_support.asp)

---

**Copyright Notification**

No part may be reproduced except as authorized by written permission.  
The copyright and the foregoing restriction extend to reproduction in all media.

© European Telecommunications Standards Institute 2010.  
All rights reserved.

**DECT**<sup>™</sup>, **PLUGTESTS**<sup>™</sup>, **UMTS**<sup>™</sup>, **TIPHON**<sup>™</sup>, the TIPHON logo and the ETSI logo are Trade Marks of ETSI registered for the benefit of its Members.

**3GPP**<sup>™</sup> is a Trade Mark of ETSI registered for the benefit of its Members and of the 3GPP Organizational Partners.

**LTE**<sup>™</sup> is a Trade Mark of ETSI currently being registered

for the benefit of its Members and of the 3GPP Organizational Partners.

**GSM**<sup>®</sup> and the GSM logo are Trade Marks registered and owned by the GSM Association.

# Contents

Intellectual Property Rights .....	6
Foreword.....	6
Introduction .....	7
1 Scope .....	8
2 References .....	8
2.1 Normative references .....	9
2.2 Informative references.....	9
3 Definitions, symbols and abbreviations .....	9
3.1 Definitions.....	9
3.2 Symbols.....	11
3.3 Abbreviations .....	12
4 Technical requirements specifications .....	13
4.1 Environmental profile.....	13
4.2 Conformance requirements .....	13
4.2.1 Introduction.....	13
4.2.2 Transmitter conducted spurious emissions .....	13
4.2.2.1 Definition .....	13
4.2.2.2 Limits .....	13
4.2.2.3 Conformance.....	16
4.2.3 Maximum output power.....	16
4.2.3.1 Definition .....	16
4.2.3.2 Limits .....	16
4.2.3.3 Conformance.....	16
4.2.4 Inter-Base Station transmitter intermodulation.....	16
4.2.4.1 Definition .....	16
4.2.4.2 Limits .....	16
4.2.4.3 Conformance.....	16
4.2.5 Receiver conducted spurious emissions.....	17
4.2.5.1 Definition .....	17
4.2.5.2 Limits .....	17
4.2.5.3 Conformance.....	17
4.2.6 Receiver blocking characteristics .....	17
4.2.6.1 Definition .....	17
4.2.6.1.1 Test Parameters .....	18
4.2.6.2 Limits .....	18
4.2.6.3 Conformance.....	18
4.2.7 Intermodulation spurious response attenuation.....	18
4.2.7.1 Definition .....	18
4.2.7.2 Limits .....	20
4.2.7.3 Conformance.....	20
4.2.8 Adjacent channel selectivity .....	20
4.2.8.1 Definition .....	20
4.2.8.1.1 Parameters .....	21
4.2.8.2 Limits .....	21
4.2.8.3 Conformance.....	21
5 Testing for compliance with technical requirements.....	22
5.1 Environmental conditions for testing .....	22
5.1.1 Introduction.....	22
5.1.2 Standard equipment under test.....	22
5.1.2.1 Basic equipment.....	22
5.1.2.2 Ancillary equipment.....	22
5.2 Interpretation of the measurement results .....	22
5.3 Essential radio test suites.....	23

5.3.1	Transmitter conducted spurious emissions .....	23
5.3.2	Maximum output power.....	23
5.3.3	Inter-Base Station transmitter intermodulation.....	23
5.3.4	Receiver conducted spurious emissions.....	24
5.3.5	Receiver blocking characteristics .....	24
5.3.6	Intermodulation spurious response attenuation.....	25
5.3.7	Adjacent channel selectivity .....	25
<b>Annex A (normative):</b>	<b>HS Requirements and conformance Test specifications Table (HS-RTT).....</b>	<b>26</b>
<b>Annex B (normative):</b>	<b>Common Procedures .....</b>	<b>28</b>
B.1	Forward and Reverse Channels and Link Assignment Block (LAB) Assignments.....	28
B.1.1	Reverse Link PER Measurement Test.....	28
B.1.2	In-Channel Selectivity Test .....	28
B.1.3	Transmitter Tests.....	28
B.1.4	Emissions Test.....	28
B.2	Session and Test Application Configurations .....	28
B.2.1	Reverse Link PER Measurement.....	28
B.2.2	In-Channel Selectivity Aggressor Configuration .....	29
B.2.3	Emissions Tests .....	29
<b>Annex C (normative):</b>	<b>Environmental profile .....</b>	<b>30</b>
C.1	Introduction .....	30
C.2	General Requirements .....	30
C.2.1	Temperature and Power Supply Voltage.....	30
C.2.1.1	Method of Measurement .....	30
C.2.2	High Humidity.....	30
C.2.3	AC Power Line Conducted Emissions .....	31
<b>Annex D (normative):</b>	<b>Standard test conditions.....</b>	<b>32</b>
D.1	Standard Equipment .....	32
D.1.1	Basic Equipment .....	32
D.1.2	Associated Equipment.....	32
D.2	Standard Environmental Test Conditions.....	32
D.3	Standard Conditions for the Primary Power Supply .....	32
D.3.1	General .....	32
D.3.2	Standard DC Test Voltage from Accumulator Batteries .....	32
D.3.3	Standard AC Voltage and Frequency .....	33
D.4	Standard Test Equipment .....	33
D.4.1	Access Terminal Simulator .....	33
D.4.2	AWGN Generator.....	33
D.4.3	CW Generator .....	33
D.4.4	Spectrum Analyzer .....	34
D.4.5	Average Power Meter.....	34
D.4.6	RF Output Load.....	35
D.5	Functional System Setups .....	35
D.5.1	Functional Block Diagrams .....	35
D.6	Standard Duty Cycle .....	38
D.7	Error Rates Measurement.....	38
D.7.1	Frame Error Rates Measurement.....	38
D.8	Confidence Limits .....	38
<b>Annex E (informative):</b>	<b>The EN title in the official languages .....</b>	<b>42</b>

**Annex F (informative): Bibliography.....43**  
History .....44

---

## Intellectual Property Rights

IPRs essential or potentially essential to the present document may have been declared to ETSI. The information pertaining to these essential IPRs, if any, is publicly available for **ETSI members and non-members**, and can be found in ETSI SR 000 314: *"Intellectual Property Rights (IPRs); Essential, or potentially Essential, IPRs notified to ETSI in respect of ETSI standards"*, which is available from the ETSI Secretariat. Latest updates are available on the ETSI Web server (<http://webapp.etsi.org/IPR/home.asp>).

Pursuant to the ETSI IPR Policy, no investigation, including IPR searches, has been carried out by ETSI. No guarantee can be given as to the existence of other IPRs not referenced in ETSI SR 000 314 (or the updates on the ETSI Web server) which are, or may be, or may become, essential to the present document.

---

## Foreword

This Harmonized European Standard (Telecommunications series) has been produced by ETSI Technical Committee Electromagnetic compatibility and Radio spectrum Matters (ERM).

The present document has been produced by ETSI in response to a mandate from the European Commission issued under Council Directive 98/34/EC [i.1] (as amended) laying down a procedure for the provision of information in the field of technical standards and regulations.

The present document is intended to become a Harmonized Standard, the reference of which will be published in the Official Journal of the European Communities referencing the Directive 1999/5/EC [i.2] of the European Parliament and of the Council of 9 March 1999 on radio equipment and telecommunications terminal equipment and the mutual recognition of their conformity ("the R&TTE Directive").

Technical specifications relevant to Directive 1999/5/EC [i.2] are given in annex A.

The present document is part 17 of a multi-part deliverable covering the Base Stations (BS), Repeaters and User Equipment (UE) for IMT-2000 Third-Generation cellular networks, as identified below:

- Part 1: "Harmonized EN for IMT-2000, introduction and common requirements, covering the essential requirements of article 3.2 of the R&TTE Directive";
- Part 2: "Harmonized EN for IMT-2000, CDMA Direct Spread (UTRA FDD and E-UTRA FDD) (UE) covering the essential requirements of article 3.2 of the R&TTE Directive";
- Part 3: "Harmonized EN for IMT-2000, CDMA Direct Spread (UTRA FDD and E-UTRA FDD) (BS) covering the essential requirements of article 3.2 of the R&TTE Directive";
- Part 4: "Harmonized EN for IMT-2000, CDMA Multi-Carrier (cdma2000) and Evolved CDMA Multi-Carrier Ultra Mobile Broadband (UMB) (UE) covering the essential requirements of article 3.2 of the R&TTE Directive";
- Part 5: "Harmonized EN for IMT-2000, CDMA Multi-Carrier (cdma2000) and Evolved CDMA Multi-Carrier Ultra Mobile Broadband (UMB) (BS) covering the essential requirements of article 3.2 of the R&TTE Directive";
- Part 6: "Harmonized EN for IMT-2000, CDMA TDD (UTRA TDD and E-UTRA TDD) (UE) covering the essential requirements of article 3.2 of the R&TTE Directive";
- Part 7: "Harmonized EN for IMT-2000, CDMA TDD (UTRA TDD and E-UTRA TDD) (BS) covering the essential requirements of article 3.2 of the R&TTE Directive";
- Part 8: "Harmonized EN for IMT-2000, TDMA Single-Carrier (UWC 136) (UE) covering essential requirements of article 3.2 of the R&TTE Directive";
- Part 9: "Harmonized EN for IMT-2000, TDMA Single-Carrier (UWC 136) (BS) covering essential requirements of article 3.2 of the R&TTE Directive";

- Part 10: "Harmonized EN for IMT-2000, FDMA/TDMA (DECT) covering essential requirements of article 3.2 of the R&TTE Directive";
- Part 11: "Harmonized EN for IMT-2000, CDMA Direct Spread (UTRA FDD and E-UTRA FDD) (Repeaters) covering the essential requirements of article 3.2 of the R&TTE Directive";
- Part 12: "Harmonized EN for IMT-2000, CDMA Multi-Carrier (cdma2000) (Repeaters) covering the essential requirements of article 3.2 of the R&TTE Directive";
- Part 13: "Harmonized EN for IMT-2000, Evolved Universal Terrestrial Radio Access (E-UTRA) (UE) covering the essential requirements of article 3.2 of the R&TTE Directive";
- Part 14: "Harmonized EN for IMT-2000, Evolved Universal Terrestrial Radio Access (E-UTRA) (BS) covering the essential requirements of article 3.2 of the R&TTE Directive";
- Part 15: "Harmonized EN for IMT-2000, Evolved Universal Terrestrial Radio Access (E-UTRA) (FDD Repeaters) covering the essential requirements of article 3.2 of the R&TTE Directive";
- Part 16: "Harmonized EN for IMT-2000, Evolved CDMA Multi-Carrier Ultra Mobile Broadband (UMB) (UE) covering the essential requirements of article 3.2 of the R&TTE Directive";
- Part 17: "Harmonized EN for IMT-2000, Evolved CDMA Multi-Carrier Ultra Mobile Broadband (UMB) (BS) covering the essential requirements of article 3.2 of the R&TTE Directive".**

<b>National transposition dates</b>	
Date of adoption of this EN:	19 February 2010
Date of latest announcement of this EN (doa):	31 May 2010
Date of latest publication of new National Standard or endorsement of this EN (dop/e):	30 November 2010
Date of withdrawal of any conflicting National Standard (dow):	30 November 2011

---

## Introduction

The present document is part of a set of standards developed by ETSI and is designed to fit in a modular structure to cover all radio and telecommunications terminal equipment within the scope of the R&TTE Directive [i.2]. The modular structure is shown in EG 201 399 [i.3].

# 1 Scope

The present document applies to the following radio equipment types:

- Base Stations (also denoted as Access Network) for Evolved CDMA Multi-Carrier Ultra Mobile Broadband (UMB) compliant with TIA-1121.001 [4].

These radio equipment types are capable of operating in all or any part of the frequency bands given table 1-1.

**Table 1-1: UMB Base Station operating bands**

Band Class (BC)	Direction of transmission	UMB Base Station operating bands
6	Transmit	2 110 MHz to 2 170 MHz
	Receive	1 920 MHz to 1 980 MHz
8	Transmit	1 805 MHz to 1 880 MHz
	Receive	1 710 MHz to 1 785 MHz
9	Transmit	925 MHz to 960 MHz
	Receive	880 MHz to 915 MHz
13	Transmit	2 620 MHz to 2 690 MHz
	Receive	2 500 MHz to 2 570 MHz

The present document covers requirements for UMB Base Stations.

The present document is intended to cover the provisions of Directive 1999/5/EC [i.2] (R&TTE Directive), Article 3.2, which states that "..... radio equipment shall be so constructed that it effectively uses the spectrum allocated to terrestrial/space radio communications and orbital resources so as to avoid harmful interference".

In addition to the present document, other ENs that specify technical requirements in respect of essential requirements under other parts of Article 3 of the R&TTE Directive [i.2] may apply to equipment within the scope of the present document.

NOTE: A list of such ENs is included on the web site <http://www.newapproach.org>.

# 2 References

References are either specific (identified by date of publication and/or edition number or version number) or non-specific.

- For a specific reference, subsequent revisions do not apply.
- Non-specific reference may be made only to a complete document or a part thereof and only in the following cases:
  - if it is accepted that it will be possible to use all future changes of the referenced document for the purposes of the referring document;
  - for informative references.

Referenced documents which are not found to be publicly available in the expected location might be found at <http://docbox.etsi.org/Reference>.

NOTE: While any hyperlinks included in this clause were valid at the time of publication ETSI cannot guarantee their long term validity.



## 2.1 Normative references

The following referenced documents are indispensable for the application of the present document. For dated references, only the edition cited applies. For non-specific references, the latest edition of the referenced document (including any amendments) applies.

- [1] ETSI EN 301 908-1 (V4.1.2): "Electromagnetic compatibility and Radio spectrum Matters (ERM); Base Stations (BS), Repeaters and User Equipment (UE) for IMT-2000 Third-Generation cellular networks; Part 1: Harmonized EN for IMT-2000, introduction and common requirements, covering the essential requirements of article 3.2 of the R&TTE Directive".

- [2] 3GPP2 C.S0088-0 V1.0, (March 2009): "Recommended Minimum Performance Standards for cdma2000 Ultra Mobile Broadband (UMB) Access Network" (to be published as TIA-1170).

NOTE: Available at [http://www.3gpp2.org/Public\\_html/specs/C.S0088\\_v1.0\\_AN\\_MPS\\_for\\_UMB-090402.pdf](http://www.3gpp2.org/Public_html/specs/C.S0088_v1.0_AN_MPS_for_UMB-090402.pdf).

- [3] ITU-R Recommendation SM.329-10 (2003): "Unwanted emissions in the spurious domain".

- [4] TIA-1121.001 (December 2007): "Physical Layer for Ultra Mobile Broadband (UMB) Air Interface Specification".

- [5] 3GPP2 C.S0089-0 Version 1.0, (March 2009): "Recommended Minimum Performance Standards for cdma2000 Ultra Mobile Broadband Access Terminal" (to be published as TIA-1171).

NOTE: Available at [http://www.3gpp2.org/Public\\_html/specs/C.S0089\\_v1.0\\_AT\\_MPS\\_for\\_UMB-090402.pdf](http://www.3gpp2.org/Public_html/specs/C.S0089_v1.0_AT_MPS_for_UMB-090402.pdf).

- [6] 3GPP2 C.S0090-0 Version 1.0, (March 2009): "Test Application Specification for cdma2000 Ultra Mobile Broadband (UMB)" (to be published as TIA-1172).

NOTE: Available at [http://www.3gpp2.org/Public\\_html/specs/C.S0090-0\\_v1.0\\_TAS\\_for\\_UMB-090402.pdf](http://www.3gpp2.org/Public_html/specs/C.S0090-0_v1.0_TAS_for_UMB-090402.pdf).

## 2.2 Informative references

The following referenced documents are not essential to the use of the present document but they assist the user with regard to a particular subject area. For non-specific references, the latest version of the referenced document (including any amendments) applies.

- [i.1] Directive 98/34/EC of the European Parliament and of the Council of 22 June 1998 laying down a procedure for the provision of information in the field of technical standards and regulations.
- [i.2] Directive 1999/5/EC of the European Parliament and of the Council of 9 March 1999 on radio equipment and telecommunications terminal equipment and the mutual recognition of their conformity (R&TTE Directive).
- [i.3] ETSI EG 201 399: "Electromagnetic compatibility and Radio spectrum Matters (ERM); A guide to the production of candidate Harmonized Standards for application under the R&TTE Directive".

---

# 3 Definitions, symbols and abbreviations

## 3.1 Definitions

For the purposes of the present document, the following terms and definitions apply:

**access network:** network equipment providing data connectivity between a packet switched data network (typically the Internet) and the access terminals

NOTE: Connectivity is typically provided at the Link Layer (PPP). An access network is equivalent to a Base Station in TIA-1121.001 [4]. In the context of transmitter testing, an access network applies to operation with a single carrier and single sector active only.

**access terminal:** device providing data connectivity to a user

NOTE: An access terminal may be connected to a computing device such as a laptop personal computer or may be self-contained data device such as a personal digital assistant.

**ACK channel:** used by the access terminal to inform the access network whether a data packet transmitted on the Forward Traffic Channel has been received successfully or not

**active set:** set of pilots assigned to a particular access terminal

**adjacent channel leakage power ratio:** ratio of the on-channel transmit power to the power measured in one of the adjacent channels with no active channel in the adjacent channel

**band class:** set of frequency channels and a numbering scheme for these channels

**Code Division Multiple Access (CDMA):** technique for spread-spectrum multiple-access digital communications that creates channels through the use of unique code sequences

**control channel:** portion of the Forward Channel that carries control information

**Effective Isotropic Radiated Power (EIRP):** product of the power supplied to the antenna and the antenna gain in a direction relative to an isotropic antenna

**Effective Radiated Power (ERP):** product of the power supplied to the antenna and the antenna gain relative to a half-wave dipole in a given direction

**error:** when referring to packet error, an error event occurs when a packet FCS does not check

NOTE: When referring to a symbol error, an error event occurs when the symbol is classified as a valid symbol different from the transmitted symbol.

**forward channel:** UMB Channel from an access network to access terminals

NOTE: The Forward Channel is transmitted on a CDMA frequency assignment using a particular pilot PN offset.

**Forward Test Application Protocol (FTAP):** Test Application protocol allowing Forward Link performance characterizations (see 3GPP2 C.S0090-0 [6])

**Forward Traffic Channel (FTC):** Forward Channel used to transport user and signalling traffic from an access network to an access terminal

**Frame Check Sequence (FCS):** Frame Check Sequence of the Physical Layer packets is a CRC (see CRC)

**Line Impedance Stabilization Network (LISN):** network inserted in the supply mains lead of apparatus to be tested that provides, in a given frequency range, a specified load impedance for the measurement of disturbance voltages and that may isolate the apparatus from the supply mains in that frequency range

**packet:** physical layer protocol data unit

**power control bit:** bit sent in every slot on the Reverse Power Control Channel that signals the access terminal to increase or decrease its transmit power

**Received Signal Quality Indicator (RSQI):** Reverse Traffic Channel measure of signal quality related to the received Data  $E_b/N_t$

NOTE: See also  $E_b$  and  $N_t$ .

**reverse channel:** UMB Channel from the access terminal to the access network

NOTE: From the access network's perspective, the Reverse Channel is the sum of all access terminal transmissions on a UMB frequency assignment.

**reverse traffic channel:** Reverse Channel used to transport user and signalling traffic from a single access terminal to one or more sectors

**sector:** part of the access network that provides the land side modem

**servicing sector:** sector which is responsible for sending data to the access terminal

**system time:** time reference used by the system. System Time is synchronous to UTC time (except for leap seconds) and uses the same time origin as Global Positioning System (GPS) time

NOTE: All sectors use the same System Time (within a small error). Access terminals use the same System Time, offset by the propagation delay from the sector to the access terminal. See also Universal Coordinated Time.

**traffic channel:** communication path between an access terminal and an access network used for user and signalling traffic

NOTE: The term Traffic Channel implies a Forward Traffic Channel and Reverse Traffic Channel pair. See also Forward Traffic Channel and Reverse Traffic Channel.

**Universal Coordinated Time (UTC):** internationally agreed-upon time scale maintained by the Bureau International de l'Heure (BIH) used as the time reference by nearly all commonly available time and frequency distribution systems, e.g. WWV, WWVH, LORAN-C, Transit, Omega, and GPS

## 3.2 Symbols

For the purposes of the present document, the following symbols apply:

Bps	Bits per second
C	Confidence level
dBc	The ratio (in dB) of the sideband power of a signal, measured in a given bandwidth at a given frequency offset from the center frequency of the same signal, to the total inband power of the signal
dBm	A measure of power expressed in terms of its ratio (in dB) to one milliwatt
dBm/Hz	A measure of power spectral density

NOTE: The ratio, dBm/Hz, is the power in one Hertz of bandwidth, where power is expressed in units of dBm.

dBW	A measure of power expressed in terms of its ratio (in dB) to one Watt
$E_b$	Average energy per information bit for the Reverse Data Channel at the sector RF input ports
$E_b/N_t$	The ratio in dB of the combined received energy per bit to the effective noise power spectral density for the Reverse Data Channel at the sector RF input ports
GHz	Gigahertz ( $10^9$ Hertz)
$I_0$	The total received power spectral density, including signal and interference, as measured at the sector RF input ports
$I_{oc}$	The power spectral density of a band-limited white noise source (simulating interference from other users and cells) as measured at the sector RF input ports
$I_{or}$	The total transmit power spectral density of the Reverse Channel at the access terminal simulator antenna connector
$\hat{I}_{or}$	The received power spectral density of the Reverse Channel as measured at the sector RF input ports
kbps	Kilobits per second
kHz	Kilohertz ( $10^3$ Hertz)
$K_{max}$	The maximum number of errors in a test procedure
km/h	Kilometers per hour
$\lambda_{lim}$	Specification error rate limit
MHz	Megahertz ( $10^6$ Hertz)
ms	Millisecond ( $10^{-3}$ second)
ns	Nanosecond ( $10^{-9}$ second)
$N_t$	The effective noise power spectral density at the sector RF input ports
ppm	Parts per million
$\mu s$	Microsecond ( $10^{-6}$ second)
$\chi^2$	Chi-squared distribution

### 3.3 Abbreviations

For the purposes of the present document, the following abbreviations apply:

AC	Alternating Current
ACLR	Adjacent Channel Leakage power Ratio
ACS	Adjacent Channel Selectivity
AWGN	Additive White Gaussian Noise
BS	Base Station
CBW	Channel BandWidth
CDMA	Code Division Multiple Access
CRC	Cyclic Redundancy Code
CW	Continuous Waveform
DC	Direct Current
E-UTRA	Evolved Universal Terrestrial Radio Access
EIRP	Effective Isotropic Radiated Power
ERP	Effective Radiated Power
FCS	Frame Check Sequence
FDD	Frequency Division Duplex
FER	Frame Error Rate
FLAB	Forward Link Assignment Block
FLCS	Forward Link Control Segment
F-PCCH	Forward Power Control Channel
FTAP	Forward Test Application Protocol
FTC	Forward Traffic Channel
GPS	Global Positioning System
HARQ	Hybrid Automatic Repeat reQuest
LAB	Link Assignment Block
LISN	Line Impedance Stabilization Network
PCP	Packet Consolidation Protocol
PER	Packet Error Rate
PN	PseudoNoise
PPP	Point-to-Point Protocol
R-ACKCH	Reverse Acknowledgement Channel
RBW	Resolution BandWidth
R-CDCCH	Reverse CDMA Dedicated Control Channel
RF	Radio Frequency
RL	Reverse Link
RLAB	Reverse Link Assignment Block
RMS	Root Mean Square
RSQI	Received Signal Quality Indicator
RTAP	Reverse Test Application Protocol
RTC	Reverse Traffic Channel
Rx	receive
TAP	Test Application Protocol
Tx	transmit
UMB	Ultra Mobile Broadband
UTC	Universel Temps Coordonné (Universal Coordinated Time)
UTRA	Universal Terrestrial Radio Access
VSWR	Voltage Standing Wave Ratio
WA	Wide Area

## 4 Technical requirements specifications

### 4.1 Environmental profile

The technical requirements of the present document apply under the environmental profile for operation of the equipment, which shall be declared by the supplier. The equipment shall comply with all the technical requirements of the present document at all times when operating within the boundary limits of the declared operational environmental profile.

For guidance on how a supplier can declare the environmental profile, see annex D.

### 4.2 Conformance requirements

The requirements in the present document are based on the assumption that the operating band (band class 6, 8, 9 and 13) is shared between systems of the IMT-2000 family (for band classes 8 and 9 also GSM) or systems having compatible characteristics.

#### 4.2.1 Introduction

To meet the essential requirement under article 3.2 of Directive 1999/5/EC [i.2] (R&TTE Directive) for IMT-2000 Base Station (BS) seven essential parameters in addition to those in EN 301 908-1 [1] have been identified. Table 4.2.1-1 provides a cross reference between these seven essential parameters and the seven corresponding technical requirements for equipment within the scope of the present document.

**Table 4.2.1-1: Cross references**

Essential parameter	Corresponding technical requirements with reference
Spectrum emissions mask	4.2.2 Transmitter conducted spurious emissions
Conducted spurious emissions from the transmitter antenna connector	4.2.2 Transmitter conducted spurious emissions
Accuracy of maximum output power	4.2.3 Base Station maximum output power
Intermodulation attenuation of the transmitter	4.2.4 Inter-Base Station transmitter intermodulation
Conducted spurious emissions from the receiver antenna connector	4.2.5 Receiver spurious emissions (Conducted spurious emissions when not transmitting)
Impact of interference on receiver performance	4.2.6 Receiver blocking characteristics
	4.2.7 Intermodulation spurious response attenuation
Receiver adjacent channel selectivity	4.2.8 Adjacent Channel Selectivity (ACS)

#### 4.2.2 Transmitter conducted spurious emissions

##### 4.2.2.1 Definition

The conducted spurious emissions are emissions at frequencies that are outside the assigned UMB Channel, measured at the sector RF output port.

##### 4.2.2.2 Limits

When transmitting with carrier frequencies less than 1 GHz (i.e. when transmitting in BC 9), the spurious emissions shall be less than the limits specified in table 4.2.2.2-1. When transmitting with carrier frequencies higher than 1 GHz (BC 6, 8, 13), the spurious emissions shall be less than the limits specified in table 4.2.2.2-2. The out-of-band spurious emissions shall be less than the limits specified in table 4.2.2.2-3. The spurious emissions shall be less than the limits for the protection of the access network receiver as specified in table 4.2.2.2-4.

Coexistence requirements may be applied for the protection of access terminal and/or access network operating in other frequency bands in the same geographical area. The requirements may apply in geographic areas in which both UMB FDD operating in frequency band classes 6, 8, 9 and 13 and a system operating in another frequency band than the UMB operating band are deployed. The power of any spurious emission shall not exceed the limits of table 4.2.2.2-5 for an access network where requirements for co-existence with the system listed in the first column apply.

The requirements for coexistence with co-located access networks may be applied for the protection of other access network receivers when GSM900, DCS1800, PCS1900, GSM850, FDD UTRA are co-located with a UMB FDD access network. The power of any spurious emission shall not exceed the limits of table 4.2.2.2-6 for a Wide Area (WA) access network where requirements for co-location with an access network type listed in the first column apply. The measured ACLR shall be equal to or more than the limits specified in table 4.2.2.2-7.

**Table 4.2.2.2-1: Band class 9 Transmitter Spurious Emission Limits**

Frequency offset			Emission Limit			Comments	
$\Delta f$ , MHz				Unit	RBW, kHz	Restrictions	Applicable range
0	to	5	$-7 - 7/5 \times \Delta f$	dBm	100	all CBW $\geq$ 5 MHz	$f_c < 1$ GHz
5	to	10	-14	dBm	100	all CBW $\geq$ 5 MHz	$f_c < 1$ GHz
10	to	$\Delta f_{max}$	-16	dBm	100	all CBW $\geq$ 5 MHz	$f_c < 1$ GHz

**Table 4.2.2.2-2: Band classes 6, 8, 13 Transmitter Spurious Emission Limits**

Frequency offset			Emission Limit			Comments	
$\Delta f$ , MHz				Unit	RBW, kHz	Restrictions	Applicable range
0	to	5	$-7 - 7/5 \times \Delta f$	dBm	100	all CBW $\geq$ 5 MHz	$f_c > 1$ GHz
5	to	10	-14	dBm	100	all CBW $\geq$ 5 MHz	$f_c > 1$ GHz
10	to	$\Delta f_{max}$	-15	dBm	1 000	all CBW $\geq$ 5 MHz	$f_c > 1$ GHz

**Table 4.2.2.2-3: Out of Band Spurious Emission Limits**

Band	Maximum Level	Measurement Bandwidth	Note
9 kHz to 150 kHz	-36 dBm	1 kHz	Note 1
150 kHz to 30 MHz	-36 dBm	10 kHz	Note 1
30 MHz to 1 GHz	-36 dBm	100 kHz	Note 1
1 GHz to 12,75 GHz	-30 dBm	1 MHz	Note 2

NOTE 1: Bandwidth as in ITU-R Recommendation SM.329-10 [3], section 4.1.  
NOTE 2: Bandwidth as in ITU-R Recommendation SM.329-10 [3], section 4.1. Upper frequency as in ITU-R Recommendation SM.329-10 [3], section 2.5 table 1.

**Table 4.2.2.2-4: Wide Area Access Network Spurious Emission Limits for Protection of Access Network Receiver**

Operating Bands	Access Network class	Maximum Level	Measurement Bandwidth
All	Wide Area	-96 dBm	100 kHz
All	Local Area	-82 dBm	100 kHz

**Table 4.2.2.2-5: Access Network Spurious emissions limits for UMB FDD Access Networks in geographic coverage area of systems operating in other frequency bands**

System type operating in the same geographical area	Band for co-existence requirement	Maximum Level	Measurement Bandwidth	Note
GSM900	921 MHz to 960 MHz	-57 dBm	100 kHz	This requirement does not apply to UMB AN operating in BC9.
	876 MHz to 915 MHz	-61 dBm	100 kHz	For the frequency range 880 MHz to 915 MHz, this requirement does not apply to UMB AN operating in BC9, since it is already covered by the requirement in table 4.2.2.2-4.
DCS1800	1 805 MHz to 1 880 MHz	-47 dBm	100 kHz	This requirement does not apply to UMB AN operating in BC8.
	1 710 MHz to 1 785 MHz	-61 dBm	100 kHz	This requirement does not apply to UMB AN operating in BC8, since it is already covered by the requirement in table 4.2.2.2-4.
UMB FDD BC6	2 110 MHz to 2 170 MHz	-52 dBm	1 MHz	This requirement does not apply to UMB AN operating in BC6.
	1 920 MHz to 1 980 MHz	-49 dBm	1 MHz	This requirement does not apply to UMB AN operating in BC6, since it is already covered by the requirement in table 4.2.2.2-4.
UMB FDD BC8	1 805 MHz to 1 880 MHz	-52 dBm	1 MHz	This requirement does not apply to UMB AN operating in BC8.
	1 710 MHz to 1 785 MHz	-49 dBm	1 MHz	This requirement does not apply to UMB AN operating in BC8, since it is already covered by the requirement in table 4.2.2.2-4.
UMB FDD BC13	2 620 MHz to 2 690 MHz	-52 dBm	1 MHz	This requirement does not apply to UMB AN operating in BC13.
	2 500 MHz to 2 570 MHz	-49 dBm	1 MHz	This requirement does not apply to UMB AN operating in BC13, since it is already covered by the requirement in table 4.2.2.2-4.
UMB FDD BC9	925 MHz to 960 MHz	-52 dBm	1 MHz	This requirement does not apply to UMB AN operating in BC9.
	880 MHz to 915 MHz	-49 dBm	1 MHz	This requirement does not apply to UMB AN operating in BC9, since it is already covered by the requirement in table 4.2.2.2-4.

**Table 4.2.2.2-6: Access Network Spurious emissions limits for Wide Area FDD AN co-located with another Access Network**

Type of co-located AN	Band for co-location requirement	Maximum Level	Measurement Bandwidth
Macro GSM900	876 MHz to 915 MHz	-98 dBm	100 kHz
Macro DCS1800	1 710 MHz to 1 785 MHz	-98 dBm	100 kHz
WA UMB FDD BC6	1 920 MHz to 1 980 MHz	-96 dBm	100 kHz
WA UMB FDD BC8	1 710 MHz to 1 785 MHz	-96 dBm	100 kHz
WA UMB FDD BC13	2 500 MHz to 2 570 MHz	-96 dBm	100 KHz
WA UMB FDD BC9	880 MHz to 915 MHz	-96 dBm	100 KHz

Table 4.2.2.2-7: ACLR Limits

UMB Channel BW (MHz)	ACLR limit for 1 <sup>st</sup> and 2 <sup>nd</sup> Adjacent channel relative to assigned channel frequency (dB)				
		UMB < 5 MHz	UMB 5 MHz	UMB 10 MHz	UMB 20 MHz
	< 5	ACLR 1	45	-	-
	ACLR 2	45	-	-	-
5	ACLR 1	45	45	-	-
	ACLR 2	45	45	-	-
10	ACLR 1	45	-	45	-
	ACLR 2	45	-	45	-
20	ACLR 1	45	-	-	45
	ACLR 2	45	-	-	45

NOTE: Measured with a rectangular filter with a bandwidth equal to the channel bandwidth on the 1<sup>st</sup> or 2<sup>nd</sup> adjacent channel.

### 4.2.2.3 Conformance

Conformance tests described in clause 5.3.1 shall be carried out.

## 4.2.3 Maximum output power

### 4.2.3.1 Definition

Maximum output power is the mean power delivered to a load with resistance equal to the nominal load impedance of the transmitter.

### 4.2.3.2 Limits

The mean power shall remain +2 dB and -4 dB of the manufacturer's rated power for the equipment over the environmental conditions described in clause 5.

### 4.2.3.3 Conformance

Conformance tests described in clause 5.3.2 shall be carried out.

## 4.2.4 Inter-Base Station transmitter intermodulation

### 4.2.4.1 Definition

Inter-Base Station transmitter intermodulation (inter-Base Station and inter-sector are synonymous) occurs when an external signal source is introduced to the antenna connector of the Base Station. This test verifies that transmitter conducted spurious emissions are still met with the presence of the interfering source.

### 4.2.4.2 Limits

The sector shall meet the conducted spurious emission requirements in clause 4.2.2.

### 4.2.4.3 Conformance

Conformance tests described in clause 5.3.3 shall be carried out.



## 4.2.5 Receiver conducted spurious emissions

### 4.2.5.1 Definition

Conducted spurious emissions are spurious emissions generated or amplified in the Base Station equipment and appearing at the receiver RF input ports.

This requirement only applies if the Base Station is equipped with a separate RF input port.

### 4.2.5.2 Limits

The mean conducted spurious emission shall not exceed the levels in table 4.2.5.2-1.

**Table 4.2.5.2-1: General spurious emission minimum requirement**

Band	Maximum level	Measurement Bandwidth
30 MHz to 1 GHz	-57 dBm	100 kHz
1 GHz to 12,75 GHz	-47 dBm	1 MHz
Within access network Receive band	-80 dBm	30 kHz
1 884,5 MHz to 1 919,6 MHz	-41 dBm	300 kHz
NOTE: The frequency range between $2,5 \times \text{CBW}$ below the first carrier frequency and $2,5 \times \text{CBW}$ above the last carrier frequency transmitted by the AN is excluded from the requirement. However, frequencies that are more than 10 MHz below the lowest frequency of the AN transmitter operating band or more than 10 MHz above the highest frequency of the AN transmitter operating band shall not be excluded from the requirement.		

### 4.2.5.3 Conformance

Conformance tests described in clause 5.3.4 shall be carried out.

## 4.2.6 Receiver blocking characteristics

### 4.2.6.1 Definition

The blocking performance requirement of the UMB system is specified as a measure of the receiver ability to receive a desired signal at its assigned channel frequency in the presence of an unwanted interferer. Two different cases are specified: interference signals are used for this test:

- 1) in-band blocking using 1,25 MHz, 2,5 MHz or 5 MHz UMB carrier as interference signal; and
- 2) out-of-band blocking with CW signal as interference signal on frequencies other than those "close-in" to the desired channel.

## 4.2.6.1.1 Test Parameters

**Table 4.2.6.1.1-1: UMB Access Network In-Band Blocking Requirements, for Frequency Range of  $f_1$  to  $f_2$**

UMB Assigned Bandwidth (MHz)	Wanted signal mean power (dBm)	Interfering signal mean power (dBm)	Interfering signal minimum offset to the channel edge of the wanted carrier (MHz)	Type of interfering signal
1,25	<REFSENS> + 3 dB	-43	1,875	1,25 MHz UMB signal
2,5	<REFSENS> + 3 dB	-43	3,75	2,5 MHz UMB signal
5	<REFSENS> + 3 dB	-43	7,5	5 MHz UMB signal
10	<REFSENS> + 3 dB	-43	7,5	5 MHz UMB signal
20	<REFSENS> + 3 dB	-43	7,5	5 MHz UMB signal

**Table 4.2.6.1.1-2: UMB Access Network blocking requirements, centre frequency of interfering signal:  $1 - f_1$  MHz,  $f_2 - 12 750$  MHz**

UMB Assigned Bandwidth (MHz)	Wanted signal mean power (dBm)	Interfering signal mean power above access terminal mean power (dB)	Type of interfering signal
1,25	<REFSENS> + 3 dB	+75	CW carrier
2,5	<REFSENS> + 3 dB	+75	CW carrier
5	<REFSENS> + 3 dB	+75	CW carrier
10	<REFSENS> + 3 dB	+75	CW carrier
20	<REFSENS> + 3 dB	+75	CW carrier

**Table 4.2.6.1.1-3: Frequency range definition for use in tables 4.2.6.1.1-1 and 4.2.6.1.1-2**

Operating Band	$f_1$ (MHz)	$f_2$ (MHz)
All BC	20 below the lower edge of the band	20 above the upper edge of the band
BC9	20 below the lower edge of the band	10 above the upper edge of the band

## 4.2.6.2 Limits

The FER in all the tests shall not exceed 1 % with 95 % confidence (see clause D.8).

## 4.2.6.3 Conformance

Conformance tests described in clause 5.3.5 shall be carried out.

## 4.2.7 Intermodulation spurious response attenuation

## 4.2.7.1 Definition

The intermodulation spurious response attenuation requirement of the UMB system is specified as a measure of the capability of the receiver to receive a desired UMB signal in the presence of interfering signals at a carefully chosen frequency offsets such that their third order inter-modulation product falls in the desired signal channel increasing the noise floor. The desired signal is allowed to desense by at most 6 dB.

Table 4.2.7.1-1: Access network broadband intermodulation performance requirement

UMB channel bandwidth (MHz)	Configuration	Desired signal mean power (dBm)	Interfering signal mean power (dBm)	Interfering signal centre frequency offset to the channel edge of the desired carrier (MHz)	Type of interfering signal
1,25	A1 in table 4.2.7.1-3	<REFSENS> + 6 dB	-52	1,875	CW
			-52	4,375	1,25 MHz UMB signal
2,5	A2 in table 4.2.7.1-3	<REFSENS> + 6 dB	-52	3,75	CW
			-52	8,75	2,5 MHz UMB signal
5	A3 in table 4.2.7.1-3	<REFSENS> + 6 dB	-52	7,5	CW
			-52	17,5	5 MHz UMB signal
10	A3 in table 4.2.7.1-3	<REFSENS> + 6 dB	-52	7,5	CW
			-52	17,7	5 MHz UMB signal
20	A3 in table 4.2.7.1-3	<REFSENS> + 6 dB	-52	7,5	CW
			-52	17,95	5 MHz UMB signal

Table 4.2.7.1-2: Access network narrowband intermodulation performance requirement

UMB channel bandwidth (MHz)	Configuration	Wanted signal mean power (dBm)	Interfering signal mean power (dBm)	Interfering signal offset to the channel edge of the desired carrier (kHz)	Type of interfering signal
1,25	A1 in table 4.2.7.1-3	<REFSENS> + 6 dB	-52	307,2	CW
			-52	701,8	1,25 MHz UMB signal, 1 Tile (1 <sup>st</sup> tile from center)
2,5	A2 in table 4.2.7.1-3	<REFSENS> + 6 dB	-52	307,2	CW
			-52	712,4	2,5 MHz UMB signal, 1 Tile (4 <sup>th</sup> tile from center)
5	A3 in table 4.2.7.1-3	<REFSENS> + 6 dB	-52	384	CW
			-52	1 040,8	5 MHz UMB signal, 1 Tile (10 <sup>th</sup> tile from center)
10	A3 in table 4.2.7.1-3	<REFSENS> + 6 dB	-52	439,6	CW
			-52	1 348	5 MHz UMB signal, 1 Tile (8 <sup>th</sup> tile from center)
20	A3 in table 4.2.7.1-3	<REFSENS> + 6 dB	-52	474	CW
			-52	1 655,2	5 MHz UMB signal, 1 Tile (6 <sup>th</sup> tile from center)

NOTE: UMB interfering signal consists of one Tile positioned at the stated offset.

**Table 4.2.7.1-3: Encoder parameters for performance requirement tests**

Reference channel	A1 (Channel Bandwidth= 1,25 MHz)	A2 (Channel Bandwidth = 2,5 MHz)	A3 (Channel Bandwidth = 5 MHz, 10 MHz or 20 MHz)
Allocated Tiles	8	16	30
Guard Band (tiles per side)	0	0	1
Symbols per Tile	8	8	8
Modulation	QPSK	QPSK	QPSK
Packet format	0	0	0
Number of HARQ transmissions	1	1	1
Payload size (bits)	427	877	1 666
Tones per Tile	16	16	16
Data channel CRC (bits)	24	24	24
Cyclic prefix (us)	13,02	13,02	13,02
Symbol duration (us)	120,44	120,44	120,44
Frame duration (us)	963,52	963,52	963,52
PHY layer throughput [kbps]	443	910	1 729

#### 4.2.7.2 Limits

The FER in all the tests shall not exceed 1 % with 95 % confidence (see clause D.8).

#### 4.2.7.3 Conformance

Conformance tests described in clause 5.3.6 shall be carried out.

### 4.2.8 Adjacent channel selectivity

#### 4.2.8.1 Definition

Adjacent channel selectivity is defined by specifying a certain receiver performance (FER = 0,01) at a specified data rate, desired signal mean power and interfering signal mean power, where the interferer is a UMB signal located on the adjacent channel. The following two signals specify the UMB ACS requirement:

- A single Tile signal from an adjacent UMB system with minimum centre frequency offset of the interfering signal to the channel edge of a victim system equal to 272,8 kHz (241 kHz for 1,25 MHz and 2,5 MHz channel bandwidth) as shown in table 4.2.8.1.1-1.
- A wideband signal in an adjacent channel position. The wideband signal is a 5 MHz UMB carrier (1,25 MHz and 2,5 MHz UMB carrier for 1,25 MHz and 2,5 MHz channel bandwidth, respectively), independent of the UMB channel bandwidth with minimum centre frequency offset of the interfering signal to the band edge of a victim system equal to 2,5 MHz (625 kHz and 1,25 MHz for 1,25 and 2,5 MHz channel bandwidth, respectively) as shown in table 4.2.8.1.1-2.

## 4.2.8.1.1 Parameters

**Table 4.2.8.1.1-1: Access network adjacent channel selectivity (narrowband) parameters**

UMB channel bandwidth (MHz)	Desired signal mean power (dBm)	Interfering signal mean power (dBm)	Interfering Tile centre frequency offset to the channel edge of the wanted carrier (kHz)	Type of interfering signal
1,25	<REFSENS> + 6 dB	-49	$241 + m \times 153,6;$ $M = 0, 3, 7$	1,25 MHz UMB signal, 1 tile
2,5	<REFSENS> + 6 dB	-49	$241 + m \times 153,6;$ $M = 0, 8, 15$	2,5 MHz UMB signal, 1 tile
5	<REFSENS> + 6 dB	-49	$272,8 + m \times 153,6;$ $M = 0, 14, 30$	5 MHz UMB signal, 1 tile
10	<REFSENS> + 6 dB	-49	$272,8 + m \times 153,6;$ $M = 0, 14, 30$	5 MHz UMB signal, 1 tile
20	<REFSENS> + 6 dB	-49	$272,8 + m \times 153,6;$ $M = 0, 14, 30$	5 MHz UMB signal, 1 tile

NOTE: Interfering signal consisting of one Tile. The requirement applies to both upper and lower frequency edge of the UMB channel.

**Table 4.2.8.1.1-2: Access network adjacent channel selectivity (wideband) parameters**

UMB channel bandwidth (MHz)	Desired signal mean power (dBm)	Interfering signal mean power (dBm)	Interfering signal centre frequency offset to the channel edge of the wanted carrier (MHz)	Type of interfering signal
1,25	<REFSENS> + 11,5 dB	-52	0,625	1,25 MHz UMB
2,5	<REFSENS> + 9 dB	-52	1,25	2,5 MHz UMB
5	<REFSENS> + 6 dB	-52	2,5	5 MHz UMB
10	<REFSENS> + 6 dB	-52	2,5	5 MHz UMB
20	<REFSENS> + 6 dB	-52	2,5	5MHz UMB

NOTE: The requirement applies to both upper and lower frequency edge of the UMB channel.

## 4.2.8.2 Limits

The FER in all the tests shall not exceed 1 % with 95 % confidence (see clause D.8).

## 4.2.8.3 Conformance

Conformance tests described in clause 5.3.7 shall be carried out.

---

## 5 Testing for compliance with technical requirements

### 5.1 Environmental conditions for testing

#### 5.1.1 Introduction

Tests defined in the present document shall be carried out at representative points within the boundary limits of the declared operational environmental profile.

Where technical performance varies subject to environmental conditions, tests shall be carried out under a sufficient variety of environmental conditions (within the boundary limits of the declared operational environmental profile) to give confidence of compliance for the affected technical requirements.

Normally it should be sufficient for all tests to be conducted using standard test conditions except where otherwise stated (see 3GPP2 C.S0088-0 [2]). For a definition of standard test conditions and for guidance on the use of other test conditions to be used in order to show compliance reference can be made to annex D.

#### 5.1.2 Standard equipment under test

##### 5.1.2.1 Basic equipment

The equipment under test shall be assembled and any necessary adjustments shall be made in accordance with the manufacturer's instructions for the mode of operation required. When alternative modes are available, the equipment shall be assembled and adjusted in accordance with the relevant instructions. A complete series of measurements shall be made for each mode of operation.

##### 5.1.2.2 Ancillary equipment

The Base Station equipment may include ancillary equipment during tests if the ancillary equipment is normally used in the operation of the equipment under test. This would include power supplies, cabinets, antenna couplers, and receiver multi-couplers.

## 5.2 Interpretation of the measurement results

The interpretation of the results recorded in a test report for the measurements described in the present document shall be as follows:

- the measured value related to the corresponding limit shall be used to decide whether an equipment meets the requirements of the present document;
- the value of the measurement uncertainty or the accuracy of each piece of test equipment used for the measurement of each parameter shall be included in the test report; only test equipment meeting the performance requirements for standard test equipment as defined in clause D.4 (3GPP2 C.S0088-0 [2], clause 6.4);
- the test set-up of each test shall be equivalent to the test set-up descriptions in clause D.5 (3GPP2 C.S0088-0 [2]), clause 6.5);
- the recorded value of the measurement uncertainty or the recorded value of the accuracy of each piece of test equipment shall be equal to or better than the figures in clause D.8 (3GPP2 C.S0088-0 [2], clause 6.8).

## 5.3 Essential radio test suites

### 5.3.1 Transmitter conducted spurious emissions

The test shall be carried out for every band class and Channel BandWidth (CBW) supported by the sector.

- 1) Configure the sector under test and an access terminal as shown in figure D.5.1-1. The AWGN generators are not applicable in this test.
- 2) Connect a spectrum analyzer (or other suitable test equipment) to the sector RF output port, using an attenuator or directional coupler if necessary.
- 3) Ensure that the access terminal simulator and access network can use the TAP configuration as per clause B.2.3.
- 4) Fix the access network transmit power to the maximum supported for the configuration.
- 5) Set up a connection between the access terminal and start the TAP flow and ensure that the LAB assignments and channels are transmitted as per clause B.1.3.
- 6) Measure the spurious emissions using appropriate measurement bandwidth.
- 7) Measure the ACLR.

The results obtained shall be compared to the limits in clause 4.2.2.2 to prove compliance.

### 5.3.2 Maximum output power

The test shall be carried out for every band class and Channel BandWidth (CBW) supported by the sector.

- 1) Configure the sector under test and an access terminal as shown in figure D.5.1-1. The AWGN generators are not applicable in this test.
- 2) Connect the power measuring equipment to the sector RF output port.
- 3) Ensure that the access terminal simulator and access network can use the TAP configuration as per clause B.2.3.
- 4) Fix the access network transmit power to the maximum supported for the configuration.
- 5) Set up a connection between the access terminal simulator and access network and start the TAP flow and ensure that the LAB assignments and channels are transmitted as per clause B.1.3.
- 6) Measure the mean output power of the sector. The power is measured at the sector's RF output port.

The results obtained shall be compared to the limits in clause 4.2.3.2 to prove compliance.

### 5.3.3 Inter-Base Station transmitter intermodulation

The test shall be carried out for every band class and the maximum bandwidth (denoted by B in the following steps) supported by the sector.

- 1) Connect the two sectors under test and two access terminal simulators as shown in figure D.5.1-3. Configure the setup so that sector 2 total power is 30 dB less than the power of sector 1. The frequency offset of the centre frequency of the interference signal shall be  $B/2 + 2,5$  MHz and  $-B/2 - 2,5$  MHz from the desired signal carrier centre frequency, but excluded are interference frequencies that are partially or completely outside of operating frequency band of the Base Station.
- 2) Connect a spectrum analyzer (or other suitable test equipment) to the sector RF output port, using an attenuator or directional coupler if necessary.
- 3) Ensure that the access terminal simulators and access network can use the TAP configuration as per clause B.2.3.

- 4) Fix the sector 1 transmit power to the maximum supported for the configuration.
- 5) Set up a connection between the access terminal simulator 1 and sector 1 and access terminal simulator 2 and sector 2 and start the TAP flows and ensure that the LAB assignments and channels are transmitted as per clause B.1.3.
- 6) Measure the mean power level at the carrier frequency for sector 1. Measure the spurious emissions for sector 1.

The results obtained shall be compared to the limits in clause 4.2.4.2 to prove compliance.

### 5.3.4 Receiver conducted spurious emissions

- 1) Connect a spectrum analyzer (or other suitable test equipment) to a receiver RF input port.
- 2) For each band class that the sector supports, configure the sector to operate in that band class and perform steps 3) through 5).
- 3) Disable all transmitter RF outputs.
- 4) Perform step 5) for all receiver input ports.
- 5) Sweep the spectrum analyzer over a frequency range from the lowest intermediate frequency or lowest oscillator frequency used in the receiver or 1 MHz, whichever is lower, to at least 2 600 MHz for band class 9 or at least 6 GHz for band class 8. For band classes 6 and 13, sweep the spectrum analyzer over a frequency range from 30 MHz to at least 12,75 GHz and measure the spurious emissions levels.

The results shall be compared to the limits in clause 4.2.5.2 to prove compliance.

### 5.3.5 Receiver blocking characteristics

The test shall be carried out for band class 6, 8, 9 and 13 and Channel BandWidth (CBW) supported by the sector using the configuration as specified in table 4.2.7.1-3.

- 1) Configure the sector under test and an access terminal simulator as shown in figure D.5.1-1.
- 2) Ensure that the access terminal and access network can use the TAP configuration as per clause B.2.1.
- 3) Configure the access network to use the reference channel configuration in table 4.2.7.1-3.
- 4) Fix the access network transmit power to the maximum supported for the configuration.
- 5) Adjust the mean power of the interfering signals to the level specified in tables 4.2.6.1.1-1 and 4.2.6.1.1-2. Table 4.2.6.1.1-1 shall be used for in-band blocking and table 4.2.6.1.1-2 shall be used for the frequency range of 1 to  $f_1$  and  $f_2$  to 12,750 GHz. The frequency ranges  $f_1$  and  $f_2$  are defined in table 4.2.6.1.1-3.
- 6) Set up a connection between the access terminal and the access network and ensure that the configuration specified in step 1) is in use and that the Link Assignment Block (LAB) assignments and channels are transmitted as per clause B.1.1.
- 7) Configure the TAP to transmit a *ParameterAssignment* message instructing the access terminal simulator to fix the transmit power on the access terminal (aggressor) simulator and start the data packet transmission on the reverse link. The power level should be fixed such that the access network receiver power is at the level specified in tables 4.2.6.1.1-1 and 4.2.6.1.1-2 for the channel bandwidth being used.
- 8) Measure the FER for the TAP flow.

The results obtained shall be compared to the limit in clause 4.2.6.2 to prove compliance.



### 5.3.6 Intermodulation spurious response attenuation

The test shall be carried out for every band class and Channel BandWidth (CBW) supported by the sector using the relevant configuration as specified in tables 4.2.7.1-1 and 4.2.7.1-2.

- 1) Configure the sector under test and an access terminal simulator as shown in figure D.5.1-2.
- 2) Ensure that the access terminal and access network can use the session and TAP configuration as per clause B.2.1.
- 3) Configure the access network to use the reference channel configuration in table 4.2.7.1-3.
- 4) Fix the access network transmit power to the maximum supported for the configuration.
- 5) Adjust the mean power of the interfering signals to the level specified in tables 4.2.7.1-1 and 4.2.7.1-2.
- 6) Set up a connection between the access terminal and the access network and ensure that the configuration specified in step 1) is in use and that the Link Assignment Block (LAB) assignments and channels are transmitted as per clause B.1.1.
- 7) Configure the TAP to transmit a *ParameterAssignment* message instructing the access terminal simulator to fix the transmit power on the access terminal simulator and start the data packet transmission on the reverse link. For broadband intermodulation test, the power level should be fixed such that the access network receiver power is at the level specified in table 4.2.7.1-1. For narrowband intermodulation test, the power level should be fixed such that the access network receiver power is at the level specified in table 4.2.7.1-2.
- 8) Measure the FER for the TAP flow.

The results obtained shall be compared to the limit in clause 4.2.7.2 to prove compliance.

### 5.3.7 Adjacent channel selectivity

The test shall be carried out for every band class and Channel BandWidth (CBW) supported by the sector using the relevant configuration as specified in tables 4.2.8.1.1-1 and 4.2.8.1.1-2.

- 1) Configure the sector under test and an access terminal simulator as shown in figure D.5.1-4.
- 2) Ensure that the access terminal and access network can use the session and TAP configuration as per clause B.2.1.
- 3) Configure the access network to use the reference channel configuration in table 4.2.7.1-3.
- 4) Fix the access network transmit power to the maximum supported for the configuration.
- 5) Adjust the mean power of the interfering signals to the level specified in tables 4.2.8.1.1-1 and 4.2.8.1.1-2.
- 6) Set up a connection between the access terminal and the access network and ensure that the configuration specified in step 1) is in use and that the Link Assignment Block (LAB) assignments and channels are transmitted as per clause B.1.1.
- 7) Configure the TAP to transmit a *ParameterAssignment* message instructing the access terminal simulator to fix the transmit power on the access terminal simulator and start the data packet transmission on the reverse link. For narrowband adjacent channel selectivity test, the power level should be fixed such that the access network receiver power is at the level specified in table 4.2.8.1.1-1. For wideband adjacent channel selectivity test, the power level should be fixed such that the access network receiver power is at the level specified in table 4.2.8.1.1-1.
- 8) Measure the FER for the TAP flow.

The results obtained shall be compared to the limit in clause 4.2.8.2 to prove compliance.

## Annex A (normative): HS Requirements and conformance Test specifications Table (HS-RTT)

The HS Requirements and conformance Test specifications Table (HS-RTT) in table A-1 serves a number of purposes, as follows:

- it provides a statement of all the requirements in words and by cross reference to (a) specific clause(s) in the present document or to (a) specific clause(s) in (a) specific referenced document(s);
- it provides a statement of all the test procedures corresponding to those requirements by cross reference to (a) specific clause(s) in the present document or to (a) specific clause(s) in (a) specific referenced document(s);
- it qualifies each requirement to be either:
  - Unconditional: meaning that the requirement applies in all circumstances; or
  - Conditional: meaning that the requirement is dependant on the manufacturer having chosen to support optional functionality defined within the schedule.
- in the case of Conditional requirements, it associates the requirement with the particular optional service or functionality;
- it qualifies each test procedure to be either:
  - Essential: meaning that it is included with the Essential Radio Test Suite and therefore the requirement shall be demonstrated to be met in accordance with the referenced procedures;
  - Other: meaning that the test procedure is illustrative but other means of demonstrating compliance with the requirement are permitted.

**Table A-1: HS Requirements and conformance Test specifications Table (HS-RTT)**

<b>Harmonized Standard EN 301 908-17</b>						
The following requirements and test specifications are relevant to the presumption of conformity under the article 3.2 of the R&TTE Directive						
<b>Requirement</b>			<b>Requirement Conditionality</b>		<b>Test Specification</b>	
<b>No</b>	<b>Description</b>	<b>Reference: Clause No</b>	<b>U/C</b>	<b>Condition</b>	<b>E/O</b>	<b>Reference: Clause No</b>
1	Transmitter conducted spurious emissions	4.2.2	U		E	5.3.1
2	Base Station maximum output power	4.2.3	U		E	5.3.2
3	Inter-Base Station transmitter intermodulation	4.2.4	U		E	5.3.3
5	Receiver spurious emissions (Conducted spurious emissions when not transmitting)	4.2.5	U		E	5.3.4
6	Receiver blocking characteristics	4.2.6	U		E	5.3.5
7	Intermodulation spurious response attenuation	4.2.7	U		E	5.3.6
8	Adjacent Channel Selectivity (ACS)	4.2.8	U		E	5.3.7

**Key to columns:****Requirement:**

**No** A unique identifier for one row of the table which may be used to identify a requirement or its test specification.

**Description** A textual reference to the requirement.

**Clause Number** Identification of clause(s) defining the requirement in the present document unless another document is referenced explicitly.

**Requirement Conditionality:**

**U/C** Indicates whether the requirement is to be *unconditionally* applicable (U) or is *conditional* upon the manufacturers claimed functionality of the equipment (C).

**Condition** Explains the conditions when the requirement shall or shall not be applicable for a technical requirement which is classified "conditional".

**Test Specification:**

**E/O** Indicates whether the test specification forms part of the Essential Radio Test Suite (E) or whether it is one of the Other Test Suite (O).

**NOTE:** All tests whether "E" or "O" are relevant to the requirements. Rows designated "E" collectively make up the Essential Radio Test Suite; those designated "O" make up the Other Test Suite; for those designated "X" there is no test specified corresponding to the requirement. The completion of all tests classified "E" as specified with satisfactory outcomes is a necessary condition for a presumption of conformity. Compliance with requirements associated with tests classified "O" or "X" is a necessary condition for presumption of conformity, although conformance with the requirement may be claimed by an equivalent test or by manufacturer's assertion supported by appropriate entries in the technical construction file.

**Clause Number** Identification of clause(s) defining the test specification in the present document unless another document is referenced explicitly. Where no test is specified (that is, where the previous field is "X") this field remains blank.

---

## Annex B (normative): Common Procedures

### B.1 Forward and Reverse Channels and Link Assignment Block (LAB) Assignments

#### B.1.1 Reverse Link PER Measurement Test

LAB assignment to the access terminal simulators should force the forward and reverse link transmissions on the same interlace. This interlace shall be different from the interlaces used for RL CDMA Control Segment (R-CDCCH) and the Power Control channel (F-PCCH). Reverse Link Assignment Block (RLAB) assignment should fix the packet format on the reverse traffic channel.

Data assignment should be such that the R-ACKCH transmission is on an interlace different from that for the control channel.

#### B.1.2 In-Channel Selectivity Test

RLAB assignment to both access terminal simulators should force the forward and reverse link transmissions on the same interlace. This interlace shall be different than interlaces used for RL CDMA Control Segment (R-CDCCH) and the Power Control channel (F-PCCH). Reverse Link Assignment Block (RLAB) assignment should fix the packet format on the reverse traffic channel.

Data assignment should be such that the R-ACKCH transmission is on an interlace different from that for the control channel.

#### B.1.3 Transmitter Tests

Forward Link Assignment Block (FLAB) assignment should include mother node. Forward Link Control Segment (FLCS) should be empty.

#### B.1.4 Emissions Test

Reverse Link Assignment Block (RLAB) assignment to the access terminal simulator should force the reverse link transmissions on all interlaces. The RLAB assignment should also include mother node. The Forward Link Assignment Block (FLAB) assignment should ensure that there is no transmission on the forward link.

---

## B.2 Session and Test Application Configurations

### B.2.1 Reverse Link PER Measurement

The access network and access terminal simulator shall use the following for this test:

- 1) One active TAP flow at the access terminal simulator and the access network that will transmit full buffer packets. The TAP flows should generate data at a rate such that the physical layer at the access terminal simulator should always have data available for transmission on the Reverse Traffic Channel (RTC) and Forward Traffic Channel (FTC). The receiving TAP flow shall ignore the packets.

NOTE 1: For the access terminal simulator this can be achieved by using a TAP Packet Type of 0x01 for this flow. The stream to which this flow is mapped should have lower priority than the stream used for transmission of data packets.

- 2) One TAP flow at the access terminal simulator that generates data for transmission on the reverse link. The TAP flow should generate data at a rate such that the physical layer at the access terminal simulator should always have data available for transmission on the RTC. This flow should be started through a TAP ParameterAssignment message.

NOTE 2: This can be achieved by using a TAP Packet Type of 0x01 for this flow.

- 3) The forward link and reverse link should transmit a packet only once, irrespective of the ack for the transmission received through the HARQ. The receiver should expect to receive a new packet in the next transmission on this interlace.

NOTE 3: This can be achieved by negotiating the TAP attributes NumHARQFL and NumHARQRL to a value of 1.

- 4) Access network shall use pseudorandom padding for the PCP packets and shall negotiate TAP attribute PsuedoRandomPaddingEnabledRL to 0x01.
- 5) The access terminal shall transmit only one Route Packet in a Packet Consolidation Protocol (PCP) packet.

NOTE 4: This can be achieved by negotiating a value of 0x01 for SinglePacketEncapsulationEnabled attribute of TAP protocol.

## B.2.2 In-Channel Selectivity Aggressor Configuration

The access network and access terminal simulator serving as the aggressor shall use the followings for this test:

- 1) One active TAP flow at the access terminal simulator and access network that will transmit full buffer packets. The TAP flows should generate data at a rate such that the physical layer at the access terminal simulator should always have data available for transmission on the RTC and FTC. The receiving TAP flow shall ignore the packets.

NOTE 1: For the access terminal simulator this can be achieved by using a TAP Packet Type of 0x01 for this flow.

- 2) The forward link and reverse link should transmit a packet only once, irrespective of the ack for the transmission received through the HARQ. The receiver should expect to receive a new packet in the next transmission on this interlace.

NOTE 2: This can be achieved by negotiating the TAP attributes NumHARQFL and NumHARQRL to a value of 1.

## B.2.3 Emissions Tests

The access network and access terminal simulator shall use an active TAP flow at the access network that will transmit full buffer data packets on the forward link. Loop back should be disabled for this flow. All other forward link and reverse link TAP flows should be disabled. Note, for the access terminal simulator this can be achieved by using a TAP Packet Type of 0x01 for this flow.

---

## Annex C (normative): Environmental profile

### C.1 Introduction

The following clause contains a copy of the description of environmental requirements as specified in 3GPP2 C.S0088-0 [2], clauses 5 and 6. This should provide some guidance on how the environmental profile can be declared for the purpose of the present document.

---

### C.2 General Requirements

#### C.2.1 Temperature and Power Supply Voltage

The temperature and voltage ranges denote the ranges of ambient temperature and power supply input voltages over which the access network will operate and meet the requirements of the present document. The ambient temperature is the average temperature of the air surrounding the access network equipment. The power supply voltage is the voltage applied at the input terminals of the access network equipment. The manufacturer is to specify the temperature range and the power supply voltage over which the equipment is to operate.

##### C.2.1.1 Method of Measurement

The access network equipment should be installed in its normal configuration (i.e. in its normal cabinet or rack mounting arrangement with all normally supplied covers installed) and placed in a temperature chamber. Optionally, the equipment containing the frequency determining element(s) may be placed in the temperature chamber if the frequency stability is to be maintained over a different temperature from that specified for the rest of the access network equipment.

The temperature chamber should be stabilized at the manufacturer's highest specified operating temperature and then should be operated in accordance with the standard duty cycle test conditions specified in annex D, and over the power supply input voltage range specified by the manufacturer. With the access network equipment operating, the temperature is to be maintained at the specified test temperature without forced circulation of air from the temperature chamber being directly applied to the access network equipment.

During the entire duty cycle, the transmitter frequency accuracy, timing reference, output power, and waveform quality should be measured as specified in 3GPP2 C.S0088-0 [2], clause 4.

Turn the access network equipment off, stabilize the equipment in the chamber at room temperature, and repeat the above measurements after a 15-minute standby warm up period.

Turn the access network equipment off, stabilize the equipment in the chamber at the coldest operating temperature specified by the manufacturer, and repeat the above measurements above after a 15-minute standby warm up period.

For transmitter frequency stability measurements, the above procedure should be repeated every 10 °C over the operating temperature range specified by the manufacturer. The equipment should be allowed to stabilize at each step before a frequency measurement is made.

#### C.2.2 High Humidity

The term "high humidity" denotes the relative humidity at which the access network will operate with no more than a specified amount of degradation in performance.

### C.2.3 AC Power Line Conducted Emissions

The AC power line conducted emissions tests should be performed on all equipment that directly connects to the public utility power line. For equipment that receives power from a device that is directly connected to the public utility power line (such as a DC power supply), the conducted emissions tests should be performed on the power supply device, with the equipment under test connected, to insure that the supply continues to meet the current emissions standards. AC power line conducted emissions tests are not required for equipment that contains an internal power source or battery supply with no means for connection to the public utility power line.

---

## Annex D (normative): Standard test conditions

### D.1 Standard Equipment

#### D.1.1 Basic Equipment

The equipment shall be assembled and any necessary adjustments shall be made in accordance with the manufacturer's instructions for the mode of operation required. When alternative modes are available, the equipment shall be assembled and adjusted in accordance with the relevant instructions. A complete series of measurements shall be made for each mode of operation.

#### D.1.2 Associated Equipment

The access network equipment may include associated equipment during tests if the associated equipment is normally used in the operation of the equipment under test. This would include power supplies, cabinets, antenna couplers, and receiver multi-couplers.

---

## D.2 Standard Environmental Test Conditions

Measurements under standard atmospheric conditions shall be carried out under any combination of the following conditions:

- Temperature: +15 °C to +35 °C
- Relative Humidity: 45 % to 75 %
- Air Pressure: 86 000 Pa to 106 000 Pa (860 mbar to 1 060 mbar)

If desired, the results of the measurements can be corrected by calculation to the standard reference temperature of 25 °C and the standard reference air pressure of 101 300 Pa (1 013 mbar).

---

## D.3 Standard Conditions for the Primary Power Supply

### D.3.1 General

The standard test voltages shall be those specified by the manufacturer as minimum, normal, and maximum operating values. The voltage shall not deviate from the stated values by more than  $\pm 2$  % during a series of measurements carried out as part of one test on the same equipment.

### D.3.2 Standard DC Test Voltage from Accumulator Batteries

The standard (or nominal) DC test voltage battery specified by the manufacturer shall be equal to the standard test voltage of the type of accumulator to be used multiplied by the number of cells minus an average DC power cable loss value that the manufacturer determines as being typical (or applicable) for a given installation. Since accumulator batteries may or may not be under charge and, in fact, may be in a state of discharge when the equipment is being operated, the manufacturer shall also test the equipment at anticipated voltage extremes above and below the standard voltage. The test voltages shall not deviate from the stated values by more than  $\pm 2$  % (nominal float voltage) during a series of measurements carried out as part of one test on the same equipment.



### D.3.3 Standard AC Voltage and Frequency

For equipment that operates from the AC mains, the standard AC test voltage shall be equal to the nominal voltage specified by the manufacturer. If the equipment is provided with different input taps, the one designated "nominal" shall be used. The standard test frequency and the test voltage shall not deviate from their nominal values by more than  $\pm 2$  %.

The equipment shall operate without degradation with input voltage variations of up to  $\pm 10$  % and shall maintain its specified transmitter frequency stability for input voltage variations of up to  $\pm 15$  %. The frequency range over which the equipment is to operate shall be specified by the manufacturer.

---

## D.4 Standard Test Equipment

### D.4.1 Access Terminal Simulator

The access terminal simulator shall be compliant with TIA-1121.001 [4] and 3GPP2 C.S0089-0 [5].

It shall be possible to disable reverse link closed loop power control in the access terminal simulator. When closed loop power control is disabled, it shall be possible to set the access terminal simulator transmit power to any fixed level with a resolution of  $\pm 0,1$  dB over the full dynamic range.

### D.4.2 AWGN Generator

The AWGN generator shall meet the following minimum performance requirements:

- Minimum Bandwidth: 1,8 MHz.
- Frequency Ranges:
  - For each band class under test, the AWGN generator must tune over the range of transmit and receive frequencies for that band class.

NOTE: The frequency ranges are based on covering the receive band and frequencies as great as 5 MHz outside the band.

- Frequency Resolution: 1 kHz.
- Output Accuracy:  $\pm 2$  dB for outputs greater than or equal to -80 dBm.
- Output Settability: 0,1 dB.
- Output Range: -20 dBm to -95 dBm.
- Gain Flatness: 1,0 dB over the minimum bandwidth.
- The AWGN generators shall be uncorrelated to the ideal transmitter signal and to each other.

### D.4.3 CW Generator

- Output Frequency Range: Tunable over applicable range of radio frequencies for band class under test.
- Frequency Accuracy:  $\pm 1$  ppm.
- Frequency Resolution: 100 Hz.
- Output Range: -50 dBm to -10 dBm, and off.
- Output Accuracy:  $\pm 1,0$  dB.
- Output Resolution: 0,1 dB.

- Output Phase Noise at -20 dBm Power:
  - -149 dBc/Hz at a frequency of 1 GHz as measured at a 285 kHz offset (band class 9).
  - -144 dBc/Hz at a frequency of 2 GHz as measured at a 655 kHz offset (band classes 6, 8 and 13).

## D.4.4 Spectrum Analyzer

The spectrum analyzer shall provide the following functionality:

- General purpose frequency domain measurements.
- Integrated channel power measurements (power spectral density in the appropriate channel bandwidth).

The spectrum analyzer shall meet the following minimum performance requirements:

- Frequency Range: Tunable over applicable range of radio frequencies.
- Frequency Resolution: 1 kHz.
- Frequency Accuracy:  $\pm 0,2$  ppm.
- Displayed Dynamic Range: 70 dB.
- Display Log Scale Fidelity:  $\pm 1$  dB over the above displayed dynamic range.
- Amplitude Measurement Range for signals from 10 MHz to either 2,6 GHz for band class 9 or 6 GHz for band classes 6, 8 and 13:
  - Power measured in 30 kHz Resolution Bandwidth: -90 dBm to +20 dBm.
  - Integrated 1,23 MHz Channel Power: -70 dBm to +47 dBm.

NOTE: The Standard RF Output Load described in clause D.4.6 may be used to meet the high power end of these measurements.

- Absolute Amplitude Accuracy in the UMB transmit and receive bands for integrated channel bandwidth channel power measurements:
  - $\pm 1$  dB over the range of -40 dBm to +20 dBm.
  - $\pm 1,3$  dB over the range of -70 dBm to +20 dBm.
- Relative Flatness:  $\pm 1,5$  dB over frequency range 10 MHz to either 2,6 GHz for band class 9 or 6 GHz for band classes 6, 8 and 13.
- Resolution Bandwidth Filter: Synchronously tuned or Gaussian (at least 3 poles) with 3 dB bandwidth selections of 1 MHz, 300 kHz, 100 kHz and 30 kHz.
- Post Detection Video Filters: Selectable in decade steps from 100 Hz to at least 1 MHz.
- Detection Modes: Average detection mode.
- RF Input Impedance: Nominal 50  $\Omega$ .

## D.4.5 Average Power Meter

The power meter shall provide the following functionality:

- Average power measurements.
- True RMS detection for both sinusoidal and non-sinusoidal signals.
- Absolute power in linear (Watt) and logarithmic (dBm) units.

- Relative (offset) power in dB and % units.
- Automatic calibration and zeroing.
- Averaging of multiple readings.

The power meter shall meet the following minimum performance requirements:

- Frequency Range: 10 MHz to either 1 GHz for band class 9 or 2 GHz for band classes 6, 8 and 13.
- Power Range: -70 dBm (100 pW) to +47 dBm (50 W):
  - Different sensors may be required to optimally provide this power range. The RF output load described in clause D.4.6 may be used to meet the high power end of these measurements.
- Absolute and Relative Power Accuracy:  $\pm 0,2$  dB (5 %):
  - Excludes sensor and source mismatch (VSWR) errors, zeroing errors (significant at bottom end of sensor range), and power linearity errors (significant at top end of sensor range).
- Power Measurement Resolution: Selectable 0,1 and 0,01 dB.
- Sensor VSWR: 1,15:1.

## D.4.6 RF Output Load

The sector transmitter output shall be connected through suitable means to the measurement equipment or access terminal simulator. The means shall be non-radiating and capable of continuously dissipating the full transmitter output power. The VSWR seen by the transmitter over the channel bandwidth centered at the nominal transmit frequency under test shall be less than 1,1:1.

The sector transmitter signal may be terminated and sampled using a dummy load, attenuator, directional coupler, or combination thereof.

---

## D.5 Functional System Setups

### D.5.1 Functional Block Diagrams

Figure D.5.1-1 through figure D.5.1-4 show the test setups used for access network testing. These are functional diagrams only. Actual test setups may differ provided the functionality remains the same.

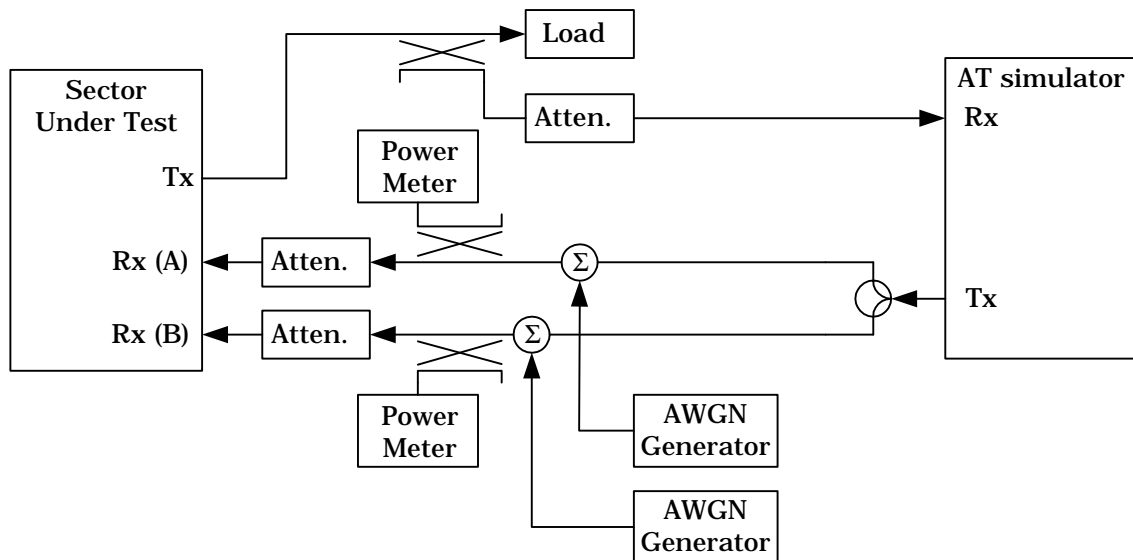

Figure D.5.1-1: Functional Setup for one Access Network AWGN Demodulation Tests and Sensitivity Tests

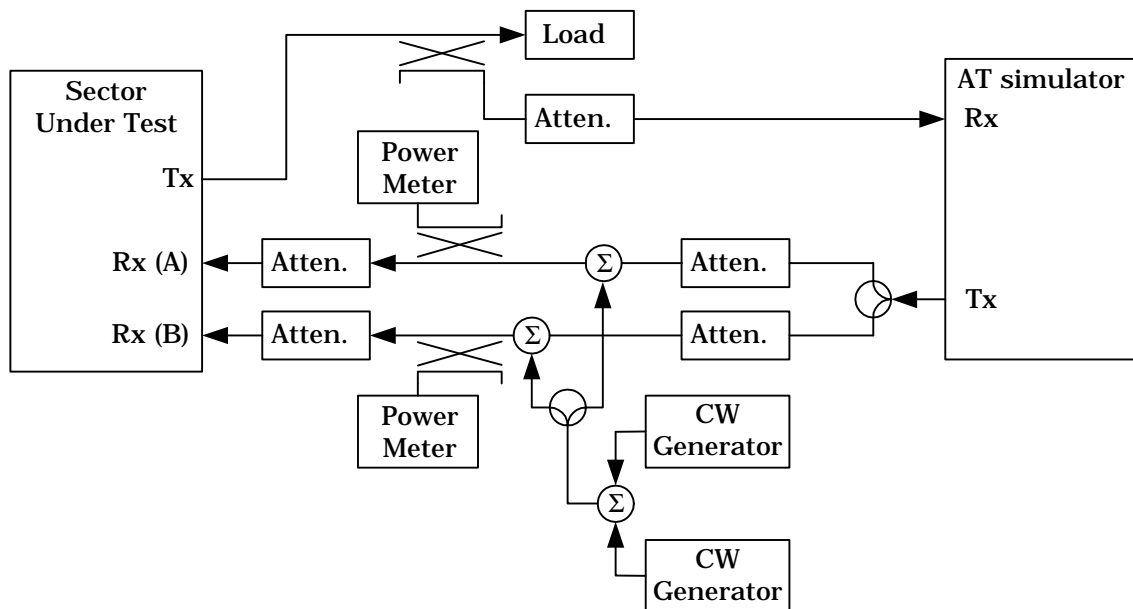

Figure D.5.1-2: Functional Setup for Access Network Intermodulation Spurious Response Tests

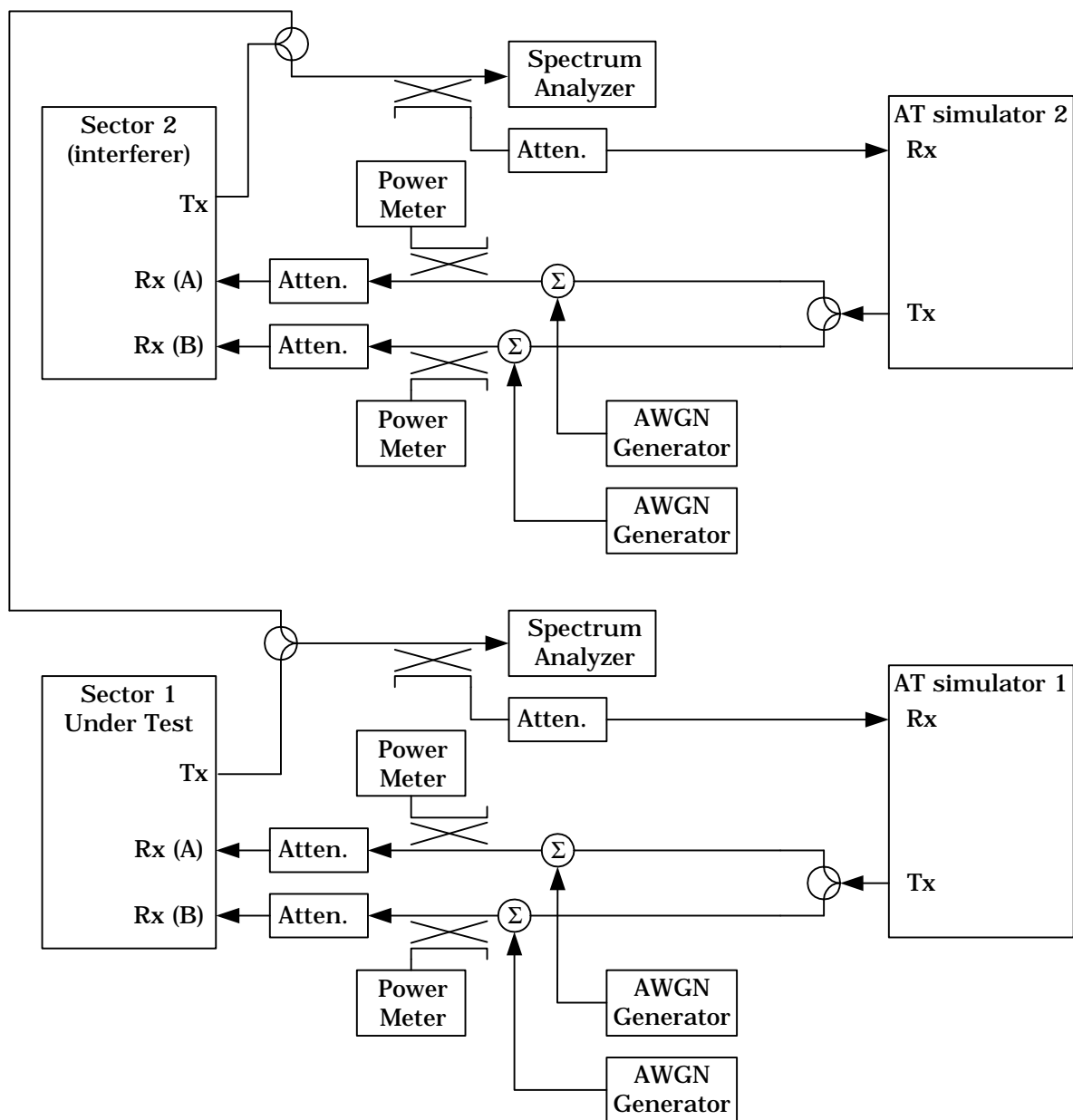

Figure D.5.1-3: Functional Setup for Emissions Tests



Any reliable statistical procedure may be used to establish the confidence level. The tests may be either single-sided or two-sided. They also may be either fixed length or variable length. The procedure shall satisfy the following requirements:

- An established procedure shall be employed. It shall include:
  - Specification of minimum and maximum test length.
  - Criteria for early termination.
- Objective pass-fail criteria shall be established.
- Steps to be taken to rerun the test in case of a failure shall be specified.

Trial-to-trial correlations of errors, as may occur in error measurements in slow fading scenarios, should be taken into account. In addition to statistical variations in measurements, systematic errors due to test equipment tolerances and calibration should be considered in interpretation of results.

An acceptable procedure is as follows. Assume independent Bernoulli trials, where the outcome of each trial is classified as either "error" or "no error". The specification error rate limit is  $\lambda_{lim}$  and the required confidence level is C.

- 1) Choose a suitable test length in terms of a maximum number of errors,  $K_{max}$ . The exact value is not critical, but must be large enough to ensure that compliant units pass with very high probability. This probability depends on the design rate ratio  $\lambda/\lambda_{lim}$  between the design error rate and the specification error rate limit. Values of  $K_{max}$  in the range of 30 to 100 should be suitable based on the margins in the present document.
- 2) Compute  $N_{max}$ :

$$N_{max} = \frac{\chi^2(1-C, 2K_{max})}{2\lambda_{lim}}$$

where  $\chi^2(P, n)$  is the value x such that  $P(X > x) = P$ , where X is a chi-squared distributed random variable with n degrees of freedom. Table D.8-1 gives  $N_{max}$  versus the actual number of errors (K) for C = 95 % and representative  $\lambda_{lim}$ . Table D.8-2 gives  $N_{max}$  versus the actual number of errors(K) for C = 90 % and representative  $\lambda_{lim}$ .

- 3) Carry out trials until one of the following conditions is met:
  - $N_{max}$  trials have been carried out.
  - $K_{max}$  errors have been made.
- 4) Being N the number of trials and  $K_N$  the number of errors when stopped. If the following condition is true:

$$N > \frac{\chi^2(1-C, 2K_N)}{2\lambda_{lim}}$$

then the unit under test has passed; otherwise the unit has failed.

- 5) If the unit fails, repeat steps 2) to 4) twice more. If the unit passes both individual tests then it passes overall; otherwise the unit has failed.

This procedure may be modified to permit early termination. A test may be performed at every trial, or after a block of trials. Steps 3' and 4' are modified as follows:

- 3'. After each trial or block of trials compute the empirical error rate as:

$$\lambda_N = \frac{K_N}{N}$$

where  $K_N$  is the number of errors up to and including the current ( $N_{th}$ ) trial, and the rate ratio  $\lambda/\lambda_{lim}$ .

4'. If after the  $N_{th}$  trial the rate ratio is less than the confidence limit:

$$\lambda_N / \lambda_{lim} < \frac{2K_N}{\chi^2(1-C, 2K_N + 2)}$$

or equivalently:

$$N > \frac{\chi^2(1-C, 2K_N + 2)}{2\lambda_{lim}}$$

then the unit under test has passed and the testing stops. If the number of trials reaches  $N_{max}$  then the unit has failed and the testing stops.

**Table D.8-1: Trial Count (N) Thresholds for 95 % Confidence**

K	$\lambda_{lim}$			General
	0,5 %	1,0 %	5,0 %	
0	599	300	60	3,00/ $\lambda_{lim}$
1	599	300	60	3,00/ $\lambda_{lim}$
2	949	474	95	4,74/ $\lambda_{lim}$
3	1 259	630	126	6,30/ $\lambda_{lim}$
4	1 551	775	155	7,75/ $\lambda_{lim}$
5	1 831	915	183	9,15/ $\lambda_{lim}$
6	2 103	1 051	210	10,51/ $\lambda_{lim}$
7	2 368	1 184	237	11,84/ $\lambda_{lim}$
8	2 630	1 315	263	13,15/ $\lambda_{lim}$
9	2 887	1 443	289	14,43/ $\lambda_{lim}$
10	3 141	1 571	314	15,71/ $\lambda_{lim}$
32	8 368	4 184	837	41,84/ $\lambda_{lim}$
64	15 540	7 770	1 554	77,70/ $\lambda_{lim}$
128	29 432	14 716	2 943	147,16/ $\lambda_{lim}$
256	56 575	28 287	5 657	282,87/ $\lambda_{lim}$

**Table D.8-2: Trial Count (N) Thresholds for 90 % Confidence**

K	$\lambda_{lim}$		General
	10,0 %	50,0 %	
0	24	5	N/A
1	24	5	2,30/ $\lambda_{lim}$
2	39	8	3,89/ $\lambda_{lim}$
3	54	11	5,32/ $\lambda_{lim}$
4	67	14	6,63/ $\lambda_{lim}$
5	80	16	8,00/ $\lambda_{lim}$
6	93	19	9,28/ $\lambda_{lim}$
7	106	22	10,53/ $\lambda_{lim}$
8	118	24	11,77/ $\lambda_{lim}$
9	130	26	13,00/ $\lambda_{lim}$
10	143	29	14,21/ $\lambda_{lim}$
32	395	79	39,43/ $\lambda_{lim}$
64	745	149	74,44/ $\lambda_{lim}$
128	1 427	286	142,70/ $\lambda_{lim}$
256	2 768	554	276,71/ $\lambda_{lim}$



In general, the rate ratio form of the test may be used with the curves of figure D.8-1. This curve is applicable to any specification error rate.

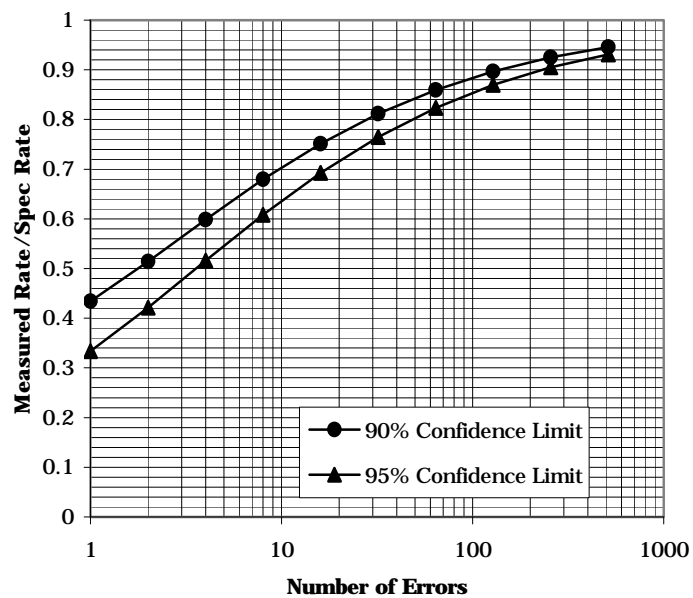

Figure D.8-1: Rate Ratio Bound as a Function of Number of Errors (K) for 90 % and 95 % Confidence

---

## Annex E (informative): The EN title in the official languages

The enlargement of the European Union (EU) resulted in a requirement from the EU for a larger number of languages for the translation of the titles of Harmonized Standards and mandated ENs that are to be listed in the Official Journal to support the implementation of this legislation.

For this reason the title translation concerning the present document can be consulted via the [e-approval](#) application.

---

## Annex F (informative): Bibliography

- Directive 2004/108/EC of the European Parliament and of the Council of 15 December 2004 on the approximation of the laws of the Member States relating to electromagnetic compatibility and repealing Directive 89/336/EEC (text with EEA relevance (EMC Directive)).
- Council Directive 73/23/EEC of 19 February 1973 on the harmonization of the laws of Member States relating to electrical equipment designed for use within certain voltage limits (LV Directive).

---

## History

<b>Document history</b>				
V4.1.1	April 2009	Public Enquiry	PE 20090828:	2009-04-30 to 2009-08-28
V4.1.2	December 2009	Vote	V 20100219:	2009-12-21 to 2010-02-19
V4.2.1	March 2010	Publication		