

Draft **ETSI EN 301 469-7** V0.0.2 (1999-11)

---

*European Standard (Telecommunications series)*

**Digital Enhanced Cordless Telecommunications (DECT);  
DECT Packet Radio Service (DPRS) Test Case Library (TCL);  
Part 7: Test Suite Structure (TSS) and Test Purposes (TP) -  
Network (NWK) layer**

---



---

**Reference**

DEN/DECT-040047-7 (dlpr001c.PDF)

---

**Keywords**

DECT, DPRS, data, network, testing, TSS&TP

**ETSI**

---

**Postal address**

F-06921 Sophia Antipolis Cedex - FRANCE

---

**Office address**

650 Route des Lucioles - Sophia Antipolis  
Valbonne - FRANCE  
Tel.: +33 4 92 94 42 00 Fax: +33 4 93 65 47 16  
Siret N° 348 623 562 00017 - NAF 742 C  
Association à but non lucratif enregistrée à la  
Sous-Préfecture de Grasse (06) N° 7803/88

---

**Internet**

secretariat@etsi.fr  
Individual copies of this ETSI deliverable  
can be downloaded from  
<http://www.etsi.org>  
If you find errors in the present document, send your  
comment to: editor@etsi.fr

---

**Important notice**

This ETSI deliverable may be made available in more than one electronic version or in print. In any case of existing or perceived difference in contents between such versions, the reference version is the Portable Document Format (PDF). In case of dispute, the reference should be the printing on ETSI printers of the PDF version kept on a specific network drive within ETSI Secretariat.

---

**Copyright Notification**

No part may be reproduced except as authorized by written permission.  
The copyright and the foregoing restriction extend to reproduction in all media.

© European Telecommunications Standards Institute 1999.  
All rights reserved.

# Contents

Intellectual Property Rights .....	5
Foreword .....	5
1 Scope .....	6
2 References .....	6
3 Definitions and abbreviations .....	7
3.1 Definitions .....	7
3.2 Abbreviations .....	7
4 Test suite structure .....	8
4.1 Overview .....	8
4.2 Test suite structure (TSS) .....	10
4.3 Test groups .....	10
4.3.1 Protocol groups .....	10
4.3.1.1 Call Control (CC) .....	10
4.3.1.2 Mobility Management (MM) .....	10
4.3.1.3 Lower Layer Management Entity (LLME) .....	10
4.3.1.4 Link Control (LC) .....	10
4.3.1.5 Call Independent Supplementary Services (CISS) .....	10
4.3.1.6 Connection Oriented Message Services (COMS) .....	10
4.3.1.7 ConnectionLess Message Services (CLMS) .....	10
4.3.2 Main test groups .....	10
4.3.2.1 Basic InTerConnection tests (IT) .....	10
4.3.2.2 CApability tests (CA) .....	11
4.3.2.3 Valid Behaviour tests (BV) .....	11
4.3.2.4 Invalid Behaviour tests (BI) .....	11
4.3.2.5 InOpportune Behaviour tests (BO) .....	11
4.3.2.6 TImeR expiry and counter mismatch tests (TI) .....	11
5 Test Purposes .....	11
5.1 Introduction .....	11
5.1.1 TP definition conventions .....	11
5.1.2 TP naming conventions .....	12
5.1.3 Sources of TP definitions .....	12
5.2 Test purposes for FT part .....	12
5.2.1 TP presentation .....	12
5.2.2 Dynamic parameters allocation and NWK layer management .....	13
5.2.3 SARI support .....	13
5.2.4 Outgoing call .....	13
5.2.5 Service Negotiation and In call service change .....	15
5.2.6 Sending keypad information .....	19
5.2.7 Incoming call .....	20
5.2.8 Internal call and Service call .....	21
5.2.9 Identification of PP and Identity Assignment .....	22
5.2.10 Authentication .....	22
5.2.11 Location registration .....	23
5.2.12 Access rights .....	25
5.2.13 On air key allocation .....	26
5.2.14 Encryption .....	26
5.2.15 DECT External handover .....	27
5.2.16 Link control .....	29
5.2.17 Message Waiting Indication .....	31
5.2.18 Distributed communication .....	31
5.2.19 MAC Suspend/Resume .....	32
5.3 Test purposes for PT part .....	33
5.3.1 TP presentation .....	33

5.3.2	Dynamic parameters allocation and NWK layer management.....	33
5.3.3	SARI support .....	33
5.3.4	Outgoing call .....	33
5.3.5	Service Negotiation and In call service change .....	36
5.3.6	Sending keypad information .....	39
5.3.7	Incoming call .....	40
5.3.8	Internal call and Service call.....	41
5.3.9	Identification of PP and Identity Assignment .....	42
5.3.10	Authentication.....	42
5.3.11	Location registration .....	44
5.3.12	Access rights .....	46
5.3.13	On air key allocation.....	47
5.3.14	Encryption.....	48
5.3.15	DECT External handover.....	49
5.3.16	Link control .....	52
5.3.17	Message Waiting Indication .....	53
5.3.18	Distributed communication.....	54
5.3.19	MAC Suspend/Resume .....	55
	Bibliography .....	56
	History .....	57

---

## Intellectual Property Rights

IPRs essential or potentially essential to the present document may have been declared to ETSI. The information pertaining to these essential IPRs, if any, is publicly available for **ETSI members and non-members**, and can be found in SR 000 314: "*Intellectual Property Rights (IPRs); Essential, or potentially Essential, IPRs notified to ETSI in respect of ETSI standards*", which is available from the ETSI Secretariat. Latest updates are available on the ETSI Web server (<http://www.etsi.org/ipr>).

Pursuant to the ETSI IPR Policy, no investigation, including IPR searches, has been carried out by ETSI. No guarantee can be given as to the existence of other IPRs not referenced in SR 000 314 (or the updates on the ETSI Web server) which are, or may be, or may become, essential to the present document.

---

## Foreword

This European Standard (Telecommunications series) has been produced by ETSI Project Digital Enhanced Cordless Telecommunications (DECT), and is now submitted for the Public Enquiry phase of the ETSI standards Two-step Approval Procedure.

The present document is Part 7 of a multi-Part EN covering the Digital Enhanced Cordless Telecommunications (DECT); DECT Packet Radio Service (DPRS) Test Case Library (TCL), as identified below:

- Part 1: "Test Suite Structure (TSS) and Test Purposes (TP) - Medium Access Control (MAC) layer";
- Part 2: "Abstract Test Suite (ATS) - Medium Access Control (MAC) layer - Portable radio Termination (PT)";
- Part 3: "Abstract Test Suite (ATS) - Medium Access Control (MAC) layer - Fixed radio Termination (FT)";
- Part 4: "Test Suite Structure (TSS) and Test Purposes (TP) - Data Link Control (DLC) layer";
- Part 5: "Abstract Test Suite (ATS) - Data Link Control (DLC) layer - Portable radio Termination (PT)";
- Part 6: "Abstract Test Suite (ATS) - Data Link Control (DLC) layer - Fixed radio Termination (FT)";
- Part 7: "Test Suite Structure (TSS) and Test Purposes (TP) - Network (NWK) layer";**
- Part 8: "Abstract Test Suite (ATS) - Network (NWK) layer - Portable radio Termination (PT)";
- Part 9: "Abstract Test Suite (ATS) - Network (NWK) layer - Fixed radio Termination (FT)".

<b>Proposed national transposition dates</b>	
Date of latest announcement of this EN (doa):	3 months after ETSI publication
Date of latest publication of new National Standard or endorsement of this EN (dop/e):	6 months after doa
Date of withdrawal of any conflicting National Standard (dow):	6 months after doa

---

# 1 Scope

The present document contains the Test Suite Structure (TSS) and Test Purposes (TP) to test the DECT Packet Radio Service (DPRS) Network (NWK) layer.

The objective of this test specification is to provide a basis for conformance tests for DECT equipment giving a high probability of air interface inter-operability between different manufacturer's DECT equipment.

The ISO standard for the methodology of conformance testing (ISO/IEC 9646-1 [9] and ISO/IEC 9646-2 [10]) as well as the ETSI rules for conformance testing (ETS 300 406 [8]) are used as a basis for the test methodology.

---

# 2 References

The following documents contain provisions which, through reference in this text, constitute provisions of the present document.

- References are either specific (identified by date of publication, edition number, version number, etc.) or non-specific.
- For a specific reference, subsequent revisions do not apply.
- For a non-specific reference, the latest version applies.
- A non-specific reference to an ETS shall also be taken to refer to later versions published as an EN with the same number.

- [1] EN 300 175-3: "Digital Enhanced Cordless Telecommunications (DECT); Common interface; Part 3: Medium access control layer".
- [2] EN 300 175-5: "Digital Enhanced Cordless Telecommunications (DECT); Common interface; Part 5: Network layer".
- [3] EN 300 175-6: "Digital Enhanced Cordless Telecommunications (DECT); Common interface; Part 6: Identities and addressing".
- [4] EN 300 175-7: "Digital Enhanced Cordless Telecommunications (DECT); Common interface; Part 7: Security features".
- [5] EN 300 444: "Digital Enhanced Cordless Telecommunications (DECT); Generic Access Profile (GAP)".
- [6] EN 301 649: "Digital Enhanced Cordless Telecommunications (DECT); DECT Packet Radio Service (DPRS)".
- [7] EN 300 824: "Digital Enhanced Cordless Telecommunications (DECT); Cordless Terminal Mobility (CTM); CTM Access Profile (CAP)".
- [8] ETS 300 406: "Methods for Testing and Specification (MTS); Protocol and profile conformance testing specifications; Standardization methodology".
- [9] ISO/IEC 9646-1 (1991): "Information technology - Open Systems InterConnection - Conformance testing methodology and framework - Part 1: General concepts". (See also CCITT Recommendation X.290 (1991)).
- [10] ISO/IEC 9646-2 (1991): "Information technology - Open Systems InterConnection - Conformance testing methodology and framework - Part 2: Abstract test suite specification". (See also CCITT Recommendation X.291 (1991)).
- [11] ISO/IEC 9646-6 (1991): "Information technology - Open Systems InterConnection - Conformance testing methodology and framework - Part 6: Protocol profile test specification".

- [12] ISO/IEC 9646-7 (1991): "Information technology - Open Systems InterConnection - Conformance testing methodology and framework - Part 7: Implementation conformance statement".

## 3 Definitions and abbreviations

### 3.1 Definitions

For the purposes of the present document, the following terms and definitions apply:

- a) the terms defined in ISO/IEC 9646-7 [12]; and
- b) the definitions in EN 300 175-5 [2].

### 3.2 Abbreviations

For the purposes of the present document, the abbreviations defined in ISO/IEC 9646-1 [9], ISO/IEC 9646-6 [11], ISO/IEC 9646-7 [12], the abbreviations defined in EN 300 175-5 [2] apply. In particular, the following definitions apply:

AC	Authentication Code
AR	Access Rights
BI	Invalid Behaviour
BO	InOpportune Behaviour
BV	Valid Behaviour
CA	Capability tests
CC	Call Control
DECT	Digital Enhanced Cordless Telecommunication
DLC	Data Link Control layer
FP	Fixed Part
FT	Fixed radio Termination
IPUI	International Portable User Identity
IUT	Implementation Under Test
LCE	Link Control Entity
LT	Lower Tester
MAC	Medium Access Control
ME	Management Entity
MM	Mobility Management
NWK	Network layer
PARK	Portable Access Rights Key
PDU	Protocol Data Unit
PICS	Protocol Implementation Conformance Statement
PIXIT	Protocol Implementation Extra Information for Testing
PP	Portable Part
PT	Portable radio termination
RFP	Radio Fixed Part
TP	Test Purposes
TSS	Test Suite Structure
UAK	User Authentication Key

## 4 Test suite structure

### 4.1 Overview

The Network (NWK) layer is layer 3 of the DECT protocol stack.

Lower	Network layer		(3)
Layer	<b>Data Link Control layer C-Plane</b>	<b>Data Link Control layer U-Plane</b>	(2b)
Management	Medium Access Control layer		(2a)
Entity	Physical layer		(1)

**Figure 1: DECT protocol stack**



Figure 2 shows the NWK (TSS) including its subgroups and defined for the conformance testing.

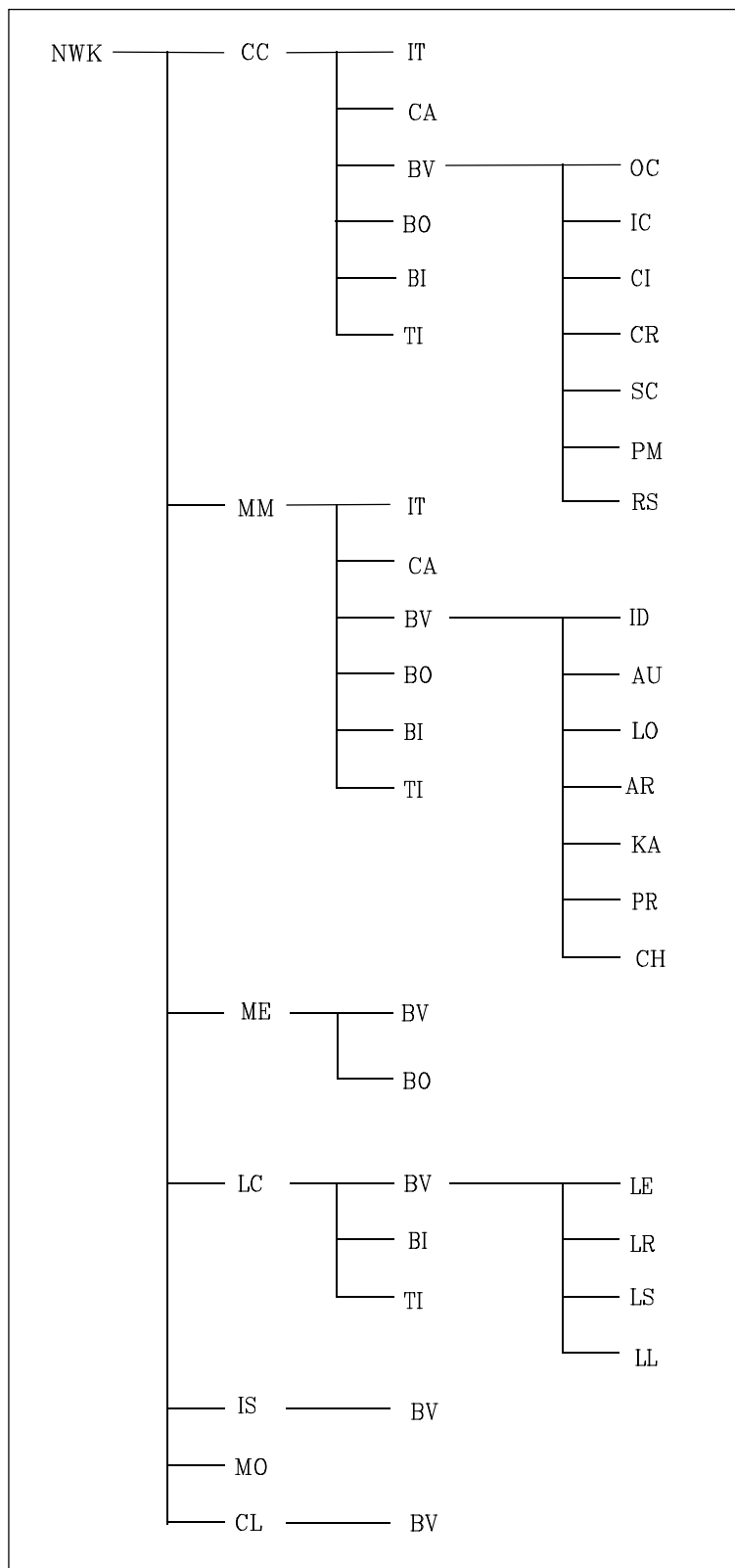

**Figure 2: NWK (TSS)**

## 4.2 Test suite structure (TSS)

The test suite is structured as a tree with a first level defined as NWK representing the protocol group "NWK for Portable Part (PP) and Fixed Part (FP)".

## 4.3 Test groups

The test groups are organized in multiple levels. The first level creates seven protocol groups representing the network entities. The last level contains the standard ISO subgroups IT, CA, BV, BO, BI, and TI.

### 4.3.1 Protocol groups

#### 4.3.1.1 Call Control (CC)

Refer to EN 300 175-5 [2], subclause 5.2 and clause 9.

#### 4.3.1.2 Mobility Management (MM)

Refer to EN 300 175-5 [2], subclause 5.6 and clause 13.

#### 4.3.1.3 Lower Layer Management Entity (LLME)

Refer to EN 300 175-5 [2], clause 15.

#### 4.3.1.4 Link Control (LC)

Refer to EN 300 175-5 [2], subclause 5.7 and clause 14.

#### 4.3.1.5 Call Independent Supplementary Services (CISS)

Refer to EN 300 175-5 [2], subclauses 5.3 and 10.4.2.2.

#### 4.3.1.6 Connection Oriented Message Services (COMS)

Refer to EN 300 175-5 [2], subclause 5.4 and clause 11.

#### 4.3.1.7 ConnectionLess Message Services (CLMS)

Refer to EN 300 175-5 [2], subclause 5.5 and clause 12.

### 4.3.2 Main test groups

#### 4.3.2.1 Basic InTerConnection tests (IT)

IT tests provide limited testing of an Implementation Under Test (IUT) in order to establish that there is sufficient conformance for possible interConnection without trying to perform thorough testing. In particular, only those test cases will be executed which will assure the sufficient interConnection between the IUT of the NWK layer and the test system exists, so that the rest of the test cases can then be put into execution.

### 4.3.2.2 CApability tests (CA)

CA tests provide limited testing that the observable capabilities of the IUT are in accordance with the static conformance requirements and the additional capabilities claimed in the Protocol Implementation Conformance Statement / Protocol Implementation Extra Information for Testing (PICS/PIXIT). In particular, this test group can be regarded as a set of spot checks for all the capabilities of the IUT stated in the PICS/PIXIT. Scope of the test group is the observable capabilities of the IUT with respect to NWK layer connection, call control, and the mobility management.

### 4.3.2.3 Valid Behaviour tests (BV)

BV group tests an IUT in response to valid behaviour of the test system. "Valid" means that a test event is syntactically and contextually correct. All test cases in the valid behaviour group are intended to verify as thoroughly as possible the various functions of the protocol.

### 4.3.2.4 Invalid Behaviour tests (BI)

BI group is intended to verify that the IUT is able to react properly in case an invalid protocol data unit (message) occurring. Invalid Protocol Data Unit (PDU) here means syntactically or semantically invalid test events generated by the test system. A syntactically or semantically invalid test event regardless of the current state is not allowed.

### 4.3.2.5 InOpportune Behaviour tests (BO)

BO test group is intended to verify that the IUT is able to react properly in case an inopportune test event occurring. Such an event is syntactically correct, but occurs when it is not allowed.

### 4.3.2.6 Timer expiry and counter mismatch tests (TI)

Different timers and counters are defined to supervise the various state transitions. This test subgroup is intended to verify that the IUT is reacting properly to an expiry of one of the timers or counters mismatch.

## 5 Test Purposes

### 5.1 Introduction

#### 5.1.1 TP definition conventions

The TPs are defined following particular rules as shown in table 1.

**Table 1: TP definition rules**

<b>TP Id according to the TP naming conventions</b>	Reference. Initial condition. Stimulus. Expected behaviour.
<b>TP Id</b>	The TP Id is a unique identifier it shall be specified according to the TP naming conventions defined in the subclause below.
<b>Reference</b>	The reference should contain the references of the subject to be validated by the actual TP (specification reference, clause, paragraph).
<b>Condition</b>	The condition defines in which initial state the IUT has to be to apply the actual TP.
<b>Stimulus</b>	The stimulus defines the test event to which the TP is related.
<b>Expected behaviour</b>	Definition of the events that are expected from the IUT to conform to the base specification.

## 5.1.2 TP naming conventions

The identifier of the TP is built according to table 2.

**Table 2: TP naming convention**

Identifier:	TP/<fm>/<x>/<s>/<nn>		
<fm> =	functional module	CC	Call Control
		MM	Mobility Management
		LC	Link Control Entity
		IS	Call Independent Supplementary Services
		CL	Connectionless Message Service
x =	Type of testing	CA	CApability Tests
		BV	Valid Behaviour Tests
		BO	Inopportune Behaviour Tests
		TI	Timer expiry and counter mismatch tests
s =	Test subgroup	OC	Outgoing Call establishment
		CI	Call Information
		CR	Call Release
		SC	Service Change
		RS	Call Related Supplementary services
		SN	Service Negotiation
		MP	Multi-purposes tests
		HP	Handover procedures
		SR	Suspend and Resume procedures
		ID	Identification
		AU	Authentication
		LO	Location
		AR	Access Rights
		KA	Key Allocation
		CH	Ciphering
		LE	Connection oriented Link Establishment
		LR	Connection oriented Link Release
<nn> =	sequential number	(01-99)	Test Purpose Number

## 5.1.3 Sources of TP definitions

All TPs are specified according to EN 300 175-5 [2] with respect to the requirements expressed in EN 301 649 [6].

## 5.2 Test purposes for FT part

### 5.2.1 TP presentation

Test purposes are presented by a logical grouping related to NWK features. The naming is in line with the test suite structure. Existing test purposes in the CI test case library are highlighted by a greyed name column.

## 5.2.2 Dynamic parameters allocation and NWK layer management

DPRS-N.38, Dynamic parameters allocation		
	Dynamic parameters allocation	EN 301 649 [6]: 12.11
DPRS-N.41, NWK layer management		
	Management of MM procedures	EN 301 649 [6]: 12.22
	Location registration initiation management	EN 300 444 [5]: 13.2
	Assigned individual TPUI management	EN 300 444 [5]: 13.4
	PMID management	EN 300 444 [5]: 13.5
	DCK management	EN 300 444 [5]: 13.6
	Broadcast attributes management	EN 301 649 [6]: 12.20
	Storage of subscription related data management	EN 301 649 [6]: 12.xx-
	U-plane handling	EN 301 649 [6]: 12.21

These two features are implicitly covered by the test purposes defined for all other NWK features.

## 5.2.3 SARI support

DPRS M.15 SARI support		
	Downlink broadcast.	EN 300 175-3 [1]: 7.2.3.6.

TP/FT/CC/BV/OC-06	M.15 SARI support. EN 300 175-3 [1]: 11.3.2, EN 300 175-6 [3]: 5.6. Initial state: F-00. Verify that the IUT can correctly establish a following outgoing call from the LT when the LT has use SARI as the means to lock to the IUT.
-------------------	---

## 5.2.4 Outgoing call

DPRS-N.1, Outgoing call		
	Outgoing call request	EN 301 649 [6]: 12.1
	Overlap sending	EN 300 444 [5]: 8.3
	Outgoing call proceeding	EN 300 444 [5]: 8.4
	Outgoing call confirmation	EN 300 444 [5]: 8.5
	Outgoing call connection	EN 300 444 [5]: 8.6
	Sending keypad information	EN 300 444 [5]: 8.10
DPRS-N.2, Off Hook		
	Outgoing call request	EN 300 444 [5]: 8.2
DPRS-N.3, On Hook (full release)		
	Normal call release	EN 300 444 [5]: 8.7
	Abnormal call release	EN 300 444 [5]: 8.8
DPRS-N.21, Partial release		
	Partial release	EN 300 444 [5]: 8.9

TP/FT/CC/BV/MP-data01	<p>DPRS-N.1, Outgoing call.  EN 301 649 [6]: 12.1, EN 300 444 [5]: 8.1, figure 1.  Initial state/Conditions: IUT is in idle_active - no subscription available.  Verify that the IUT is able after granting a subscription to the LT to perform an outgoing call using piecewise method to transfer dialling information in state F-02 if supported or F-10 otherwise, performing resources management, data transfer and proper released by the LT of the call. Possible MM procedures initiated by the IUT as Key allocation, PT authentication, Storage of DCK and FT initiated Cipherng are properly handled by the LT.</p>
<p><b>Explicitly testing:</b></p> <ul style="list-style-type: none"> <li>- Obtain access rights procedure;</li> <li>- Key allocation procedures (if started by the IUT);</li> <li>- Location registration procedure;</li> <li>- PT authentication procedure (if started by the IUT);</li> <li>- Store DCK procedure (if started by the IUT);</li> <li>- Outgoing call establishment;</li> <li>- LCE Link establishment;</li> <li>- CC-transitions;</li> <li>- FT initiating Cipherng (if started by the IUT);</li> <li>- Service negotiation (suggested characteristics accepted or not by IUT);</li> <li>- U-plane connection;</li> <li>- U-plane transfer;</li> <li>- MAC suspend/resume;</li> <li>- Service change;</li> <li>- PT initiated Call release.</li> </ul> <p><b>Expected behaviour:</b></p> <p><u>Pre call establishment:</u>  The LT(PT) shall initiate Obtain access rights procedure (set-up capabilities - fast set-up and fast paging supported); the If the IUT (FT) interrupts it with a Key allocation procedure LT shall properly response; When the Obtain access rights is accomplished successfully the LT shall perform a Location Registration procedure - IUT may assign TPUI; IUT may interrupt the Location registration with a PT authentication to verify the keys and to request DCK.</p> <p><u>Call establishment:</u>  LT shall initiate an Outgoing call; LT shall initiate link establishment; LT shall send a {CC-SETUP} suggesting lower layer resources; In its first message IUT shall provide the same or different (lower than the suggested) set of characteristics; Lower layer resources negotiation is performed; IUT may initiate cipherng and establish a DCK.</p> <p><u>Data transmission (in T-10):</u>  Establishment of all necessary resources at MAC shall be verified - file transfer from the LT or Internet session relatively high amount of data shall be ensured that the max. allowed bearers are established; After some time the Operator shall ensure that the conditions for initiation of a MAC suspend are met in the LT - LT shall request MAC suspend of the link on completion of the data transfer; if link is suspended after some time LT shall request MAC resume; LT shall transmit a small amount of data that does not require full capacity and shall request Service change reducing the max. number of bearers (LT Master); new MAC resources set shall be verified; LT shall transmit a small amount of data that does not require full capacity, data from IUT may be received.</p> <p><u>Call release:</u>  LT shall request normal release of the call.</p>	

TP/FT/CC/BV/CR-02	DPRS-N.3, On Hook (full release) EN 300 175-5 [2]: 9.5.1, EN 300 444 [5]: 8.7 Initial state: F-10 Verify that the IUT is able to perform an IUT initiated normal release.
TP/FT/CC/BV/CR-04	DPRS-N.3, On Hook (full release) EN 300 175-5 [2]: 9.5.1, EN 300 444 [5]: 8.7 Initial state: F-02 Verify that the IUT, after Part of dialling information is sent, is able to perform a PT initiated normal release.
TP/FT/CC/BV/CR-07	DPRS-N.3, On Hook (full release) EN 300 175-5 [2]: 9.5.1, EN 300 444 [5]: 8.8, figure 24 Initial state: F-07 Verify that the IUT is able to perform a PT initiated abnormal release.
TP/FT/CC/BV/CR-08	DPRS-N.3, On Hook (full release) EN 300 175-5 [2]: 9.5.1, EN 300 444 [5]: 8.8, figure 24 Initial state: F-10 Verify that the IUT is able to perform a PT initiated abnormal release.
TP/FT/CC/BV/CR-10	DPRS-N.21, Partial release EN 300 175-5 [2]: 14.2.7, EN 300 444 [5]: 8.9 Initial state: F-10 Verify that the IUT is able to perform a PT initiated partial release.
TP/FT/CC/TI-01	DPRS-N.1, Outgoing call EN 300 175-5 [2]: 9.3.1.5, EN 300 444 [5]: 8.3.2.3, Initial state: F-02 Verify that the IUT, after having started timer F-<CC.01>, sends a {CC-RELEASE} message when the timer expires after the defined time. The {CC-RELEASE} message should arrive within the allowed margin time of $\pm 5$ %.
TP/FT/CC/TI-02	DPRS-N.1, Outgoing call EN 300 175-5 [2]: 9.3.1.5, EN 300 444 [5]: 8.3.2.3, figure 12 Initial state: F-02 Verify that the IUT is able to restart the timer F-<CC.01>, on receipt of a {CC-INFO} message.
TP/FT/CC/TI-03	DPRS-N.3, On Hook (full release) EN 300 175-5 [2]: 9.5.1, EN 300 444 [5]: 8.7.1.2 Initial state: F-19 Verify that the IUT, after having started timer F-<CC.02>, sends a {CC-RELEASE-COM} message when the timer expires after the defined time. The {CC-RELEASE-COM} message should arrive within the allowed margin time of $\pm 5$ %.
TP/FT/CC/BO-02	DPRS-N.3, On Hook (full release) EN 300 175-5 [2]: 9.5.3, EN 300 444 [5]: 8.7.2.1, figure 21. Initial state: F-19 Verify that the IUT is able to react correctly on a release collision, in the sense that upon reception of a {CC-RELEASE} message in state F-19, no {CC-RELEASE-COM} message is sent back, and the call is cleared.

## 5.2.5 Service Negotiation and In call service change

DPRS-N.39, Service Negotiation		
	Call Resources/Parameters negotiation	EN 301 649 [6]: 12.5
DPRS-N.40, In call service change		
	Bandwidth Change	EN 301 649 [6]: 12.6
	Connection Reversal	EN 301 649 [6]: 12.7
	Service re-routing	EN 301 649 [6]: 12.8
	IWU-attributes change	EN 301 649 [6]: 12.9

TP/FT/CC/BV/SN-data01	DPRS-N.39, Service Negotiation EN 300 444 [5]: 8.11, figure 28 Initial state/Conditions: F-00, subscription available (if not the test will request it). Verify that the IUT is able to perform a CC-state transition from the F-00 state to F-10 state via F-06 and F-07 for an incoming normal call set-up. The LT suggest different, lower than the requested by the IUT values of "Target bearers" in the <<Connection attributes>>.
TP/FT/CC/BV/SN-data02	DPRS-N.39, Service Negotiation EN 300 444 [5]: 8.11, figure 28 Initial state/Conditions: F-00, subscription available (if not the test will request it). Verify that the IUT is able to perform a CC-state transition from the F-00 state to F-10 state via F-06 and F-07 for an incoming normal call set-up. The LT suggest different, lower than the requested by the IUT values of <MAC packet life time> in the <<Connection attributes>>.
TP/FT/CC/BV/SN-data03	DPRS-N.39, Service Negotiation EN 300 444 [5]: 8.11, figure 28 Initial state/Conditions: F-00, subscription available (if not the test will request it). Verify that the IUT is able to perform a CC-state transition from the F-00 state to F-10 state via F-06 and F-07 for an incoming normal call set-up. The LT suggest different, lower than the requested by the IUT values of the <<Window size>>.
TP/FT/CC/BV/SN-data04	DPRS-N.39, Service Negotiation EN 300 444 [5]: 8.11, figure 28 Initial state/Conditions: F-00, subscription available (if not the test will request it). Verify that the IUT is able to perform a CC-state transition from the F-00 state to F-10 state via F-06 and F-07 for an incoming normal call set-up. The LT suggest different values of the <<IWU attributes>>.



TP/FT/CC/BV/SC-data01	DPRS-N.40, In call service change EN 301 649 [6]: 12.9 Initial state/Conditions: F-10, subscription available (if not the test will request it). Verify that the IUT is able to perform correctly the Service change procedure when initiated by the LT(PT); initiating side is the Master. The LT suggest different values of the <<IWU attributes>>.
TP/FT/CC/BV/SC-data02	DPRS-N.40, In call service change EN 301 649 [6]: 12.9 Initial state/Conditions: F-10, subscription available (if not the test will request it). Verify that the IUT is able to perform correctly the Service change procedure when initiated by the LT(PT); receiving side is the Master. The LT suggest different values of the <<IWU attributes>>.
TP/FT/CC/BV/SC-data03	DPRS-N.40, In call service change EN 301 649 [6]: 12.6 Initial state/Conditions: F-10, subscription available (if not the test will request it). Verify that the IUT is able to perform correctly the Service change procedure when initiated by the LT(PT); initiating side is the Master. The LT suggests "bandwidth change" and different values of the <<Connection attributes>>.
TP/FT/CC/BV/SC-data04	DPRS-N.40, In call service change EN 301 649 [6]: 12.6 Initial state/Conditions: F-10, subscription available (if not the test will request it). Verify that the IUT is able to perform correctly the Service change procedure when initiated by the LT(PT); receiving side is the Master. The LT suggests "bandwidth change" and different values of the <<Connection attributes>>.
TP/FT/CC/BV/SC-data05	DPRS-N.40, In call service change EN 301 649 [6]: 12.7 Initial state/Conditions: F-10, subscription available (if not the test will request it). Verify that the IUT is able to perform correctly the Service change procedure when initiated by the LT(PT); initiating side is the Master. The LT suggests "Connection reversal" and different values of the <<Connection attributes>>.
TP/FT/CC/BV/SC-data06	DPRS-N.40, In call service change EN 301 649 [6]: 12.7 Initial state/Conditions: F-10, subscription available (if not the test will request it). Verify that the IUT is able to perform correctly the Service change procedure when initiated by the LT(PT); receiving side is the Master. The LT suggests "Connection reversal" and different values of the <<Connection attributes>>.
<b>Expected behaviour:</b> LT Establishes an Outgoing call as Lower layer resources negotiation shall be accomplished with information included from the LT in CC-SETUP, and from IUT in the first response message; LT(PT) shall initiate the Service change procedure; Resource allocation at MAC shall be initiated by the Master as specified during the procedure; When accomplished the U-plane shall be checked again; Normal Release of the call shall be requested from the LT.	

TP/FT/CC/BV/SC-data07	<p>DPRS-N.40, In call service change  EN 301 649 [6]: 12.9  Initial state/Conditions: F-10, subscription available (if not the test will request it).  <u>For IUT that can invoke such service change.</u>  Verify that the IUT is able to perform correctly the Service change procedure when initiated by the IUT(FT); Master side specified by the IUT. The IUT suggest different values of the &lt;&lt;IWU attributes&gt;&gt;.</p>
TP/FT/CC/BV/SC-data08	<p>DPRS-N.40, In call service change  EN 301 649 [6]: 12.6  Initial state/Conditions: F-10, subscription available (if not the test will request it).  <u>For IUT that can invoke such service change.</u>  Verify that the IUT is able to perform correctly the Service change procedure when initiated by the IUT(FT); Master side specified by the IUT. The IUT suggests "bandwidth change" and different values of the &lt;&lt;Connection attributes&gt;&gt;.</p>
TP/FT/CC/BV/SC-data09	<p>DPRS-N.40, In call service change  EN 301 649 [6]: 12.7  Initial state/Conditions: F-10, subscription available (if not the test will request it).  <u>For IUT that can invoke such service change.</u>  Verify that the IUT is able to perform correctly the Service change procedure when initiated by the IUT(FT); Master side specified by the IUT. The IUT suggests "Connection reversal" and different values of the &lt;&lt;Connection attributes&gt;&gt;.</p>
<p><b>Expected behaviour:</b>  IUT shall establish an incoming call as Lower layer resources negotiation shall be accomplished with information included from the IUT in CC-SETUP, and from LT in CC-ALERTING; IUT shall be requested to initiate the Service change procedure; Resource allocation at MAC shall be initiated by the Master as specified during the procedure; When accomplished the U-plane shall be checked again; Normal Release of the call shall be requested from the LT.</p>	

## 5.2.6 Sending keypad information

DPRS-N.4, Dialed digits (basic) DPRS-N.5, Register recall DPRS-N.6, Go to DTMF signalling (defined tone length) DPRS-N.7, Pause (dialling pause) DPRS-N.22, Go to DTMF (infinite tone length) DPRS-N.23, Go to Pulse		
	Sending keypad information	EN 300 444 [5]: 8.10

TP/FT/CC/BV/CI-03	DPRS-N.23, Go to Pulse EN 300 175-5 [2]: 9.3.1.5, EN 300 444 [5]: 8.10, table 20 Initial state: F-02 Verify that when the IUT receives a {CC-INFO} message with a <<MULTI-KEYPAD>> information element containing keypad-info "12"H (goto pulse), the IUT from that moment on transfers dialling information to the network simulator, using pulse (decadic) dialling.
TP/FT/CC/BV/CI-05	DPRS-N.7, Pause (dialling pause) EN 300 175-5 [2]: 9.3.1.5, EN 300 444 [5]: 8.10, table 20 Initial state: F-10 Verify that when the IUT receives a {CC-INFO} message with a <<MULTI-KEYPAD>> information element containing keypad-info "05H" (dialling pause), it sends a dialling pause to the network simulator.
TP/FT/CC/BV/CI-06	DPRS-N.6, Go to DTMF signalling (defined tone length) EN 300 175-5 [2]: 9.3.1.5, EN 300 444 [5]: 8.10, table 20 Initial state: F-02 Verify that when the IUT receives a {CC-INFO} message with a <<MULTI-KEYPAD>> information element containing keypad-info "14H" (goto DTMF, defined tone length), the IUT from that moment on transfers dialling information to the network simulator, using DTMF with defined tone length.
TP/FT/CC/BV/CI-09	DPRS-N.22, Go to DTMF (infinite tone length) EN 300 175-5 [2]: 9.3.1.5, EN 300 444 [5]: 8.10, table 20 Initial state: F-10 Verify that when the IUT receives a {CC-INFO} message with a <<MULTI-KEYPAD>> information element containing keypad-info "16H" (goto DTMF, infinite tone length), the IUT from that moment on transfers dialling information to the network simulator, using DTMF with infinite tone length.
TP/FT/CC/BV/CI-10	DPRS-N.4, Dialed digits (basic) EN 300 175-5 [2]: 9.3.1.5, EN 300 444 [5]: 8.10, table 20 Initial state: F-10 Verify that when the IUT receives a {CC-INFO} message with a <<MULTI-KEYPAD>> information element containing the basic digits (0-9, star, hash mark), it transfers this information correctly to the network simulator.

## 5.2.7 Incoming call

DPRS-N.2, Off Hook		
	Incoming call connection	EN 300 444 [5]: 8.15
DPRS-N.8, Incoming call		
	Incoming call request	EN 301 649 [6]: 12.2
	Incoming call confirmation	EN 300 444 [5]: 8.13
	Incoming call connection	EN 300 444 [5]: 8.15
DPRS-N.15, Alerting		
	PT alerting	EN 300 444 [5]: 8.14
DPRS-N.30, Calling Line Identification Presentation (CLIP)		
	Incoming call request	EN 300 444 [5]: 8.12

TP/FT/CC/BV/MP-data02	<p>DPRS-N.8, Incoming call EN 301 649 [6]: 12.2, EN 300 444 [5]: 8.11, figure 28 Initial state: F-00 Verify that the IUT is able to perform an incoming call via the states F-06, F-07 and F-10 performing resources management, data transfer and proper released by the LT of the call. IUT shall handle properly the service negotiation.</p>
<p><b>Implicitly testing:</b></p> <ul style="list-style-type: none"> <li>- LCE Link establishment (FT direct or indirect);</li> <li>- Incoming Call establishment trough all CC-state;</li> <li>- PT authentication procedure (if requested by FT);</li> <li>- Store DCK procedure (if requested by FT);</li> <li>- FT initiating Ciphering (if requested by FT);</li> <li>- Service negotiation (suggested characteristics accepted from the LT);</li> <li>- U-plane connection;</li> <li>- U-plane transfer;</li> <li>- MAC suspend/resume;</li> <li>- Service change;</li> <li>- FT initiated Call release.</li> </ul> <p><b>Expected behaviour:</b></p> <p><u>Pre call establishment</u> Subscription should be available if not shall be obtained as in the outgoing call case;</p> <p><u>Call establishment</u> IUT(FT) shall be requested to initiate an Incoming call; IUT shall try Direct link establishment which the LT shall accept (set-up capabilities have to be correctly indicated beforehand to the IUT); When link has been established Incoming Call setup shall occur; Lower layer resources negotiation is performed as the information included from the IUT will be in the CC-SETUP, and from LT in CC-ALERTING - LT accepts the suggestion; IUT may initiate ciphering preceded by a PT authentication with "store DCK", LT shall respond correctly;</p> <p><u>Data transmission (in F-10)</u> As in the outgoing call cases: Establishment of all necessary resources at MAC shall be verified; LT shall transmit a relatively big amount of data which require maximum used of the resources; LT shall request MAC suspend of the link on completion of the data transfer; if link is suspended after some time LT shall request MAC resume (fast setup, fast paging, and normal paging shall be performed until one succeeds); LT shall transmit a small amount of data that does not require full capacity and shall request Service change reducing the max. number of bearers (LT Master); new MAC resources set shall be verified; LT shall transmit a small amount of data that does not require full capacity;</p> <p><u>Call release</u> IUT shall be requested to initiate a normal call release.</p>	

TP/FT/CC/BV/RS-07	DPRS-N.30, Calling Line Identification Presentation (CLIP) EN 300 175-5 [2]: 10.3, EN 300 444 [5]: 8.12, EN 300 824 [7]: 7.7, table 3 Initial state: F-00 Verify the IUT is able to transmit the <<calling party number>> information element in the {CC-SETUP} message providing the PP with the calling party number information before accepting the call.
TP/FT/CC/BV/CI-01	DPRS-N.15, Alerting EN 300 175-5 [2]: 9.3.1, EN 300 444 [5]: 8.14 Initial state: F-00 Verify that the IUT is able to send the <<SIGNAL>> information element in case of incoming call to the PT. This information element can either be in the {CC-SETUP} or in successive {CC-INFO} message.
TP/FT/CC/TI-data01	DPRS-N.8, Incoming call EN 300 175-5 [2]: 9.3.2, EN 300 444 [5]: 8.12.1.1 Initial state: F-06 Verify that the IUT, can continue with incoming call establishment when it receives the {CC-ALERTING} in a point of time shortly before the expiry of timer F-<<CC.03>. (F-<<CC.03> value - 5 %).

## 5.2.8 Internal call and Service call

DPRS-N.31, Internal call		
	Internal call set-up	EN 300 444 [5]: 8.18
	Internal call keypad	EN 301 649 [6]: 12.4
DPRS-N.32, Service call		
	Service call set-up	EN 300 444 [5]: 8.20
	Service call keypad	EN 300 444 [5]: 8.21

TP/FT/CC/BV/MP-data03	DPRS-N.31, Internal call EN 300 444 [5], 8.18, table 30 Initial state: F-00 Verify that the IUT is able to perform an Internal call set-up requested by the LT performing resources management, data transfer and proper released by the LT of the call.
<b>Explicitly testing/ Expected behaviour:</b> See TP/FT/CC/BV/MP-data01 - only difference is the content of the <<basic service>> now indicating "Internal Call". The LT and an additional PT should be subscribed to the IUT beforehand.	

TP/FT/CC/BV/MP-data04	DPRS-N.31, Internal call EN 300 444 [5], 8.18, table 31 Initial state: F-10 Verify that the IUT is able to perform an Internal call requested via a {CC-INFO} message sent by the LT in F-10 using piecewise method to transfer dialling information in state F-10 performing resources management, data transfer and proper released by the LT of the call.
<b>Explicitly testing/ Expected behaviour:</b> See TP/FT/CC/BV/MP-data01 - only differences are: the LT and an additional PT should be subscribed to IUT beforehand, in T-10 before sending dialled digits {CC-INFO} <<Multi-keypad>> "Internal Call" shall be sent by the LT.	

## 5.2.9 Identification of PP and Identity Assignment

DPRS-N.13, Identification of PP		
	Identification of PT	EN 300 444 [5]: 8.22
DPRS-N.42, Identity Assignment		
	Temporary Identity Assign	EN 301 649 [6]: 12.14

TP/FT/MM/BV/ID-01	DPRS-N.13, Identification of PP EN 300 175-5 [2]: 13.2.1, EN 300 444 [5]: 8.22 Initial state: Selected in PIXIT Verify that when the basic IUT initiated identity request procedure is invoked on the IUT, the IUT is able to perform this procedure correctly.
TP/FT/MM/BV/ID-data02	DPRS-N.42, Identity Assignment EN 301 649 [6]: 12.14 Initial state: F-00 Verify that the IUT performs properly the Temporary Identity Assign procedures assigning a group TPUI.
TP/FT/MM/TTI-01	DPRS-N.13, Identification of PP EN 300 175-5 [2]: 13.2.1, EN 300 444 [5]: 8.22.2.2 Initial state: Specified in PIXIT Verify that the IUT is capable of completing the Identification of PT procedure at a point in time 10 % before expiry of the timer F-<MM_ident.2>.

## 5.2.10 Authentication

DPRS-N.9, Authentication of the PP		
	Authentication of PT	EN 300 444 [5]: 8.24
DPRS-N.10, Authentication of the user		
	Authentication of user	EN 300 444 [5]: 8.25
DPRS-N.16, ZAP		
	Obtaining access rights	EN 300 444 [5]: 8.30
	Incrementing the ZAP value	EN 300 444 [5]: 8.26
DPRS-N.26, Authentication of FT		
	Authentication of FT	EN 300 444 [5]: 8.23

TP/FT/MM/BV/AU-01	DPRS-N.9, Authentication of the PP EN 300 175-5 [2]: 13.3.1, EN 300 444 [5]: 8.24 Initial state: Selected in PIXIT. <u>Test shall be started with obtain access rights procedure and depending on the assignment of the ZAP and Service class the LT shall include or not them in the response</u> Verify that the IUT, after invocation, is able to perform the basic operation of the authentication of PT procedure.
TP/FT/MM/BV/AU-02	DPRS-N.16, ZAP EN 300 175-5 [2]: 13.3.1, EN 300 444 [5]: 8.26, figure 52 Initial state: Selected in PIXIT Verify that the IUT, after invocation, is able to perform the basic operation of the procedure incrementing the ZAP value, during the authentication of PT procedure (PT has stored ZAP value and service class information). PT will authenticate IUT before answering.
TP/FT/MM/BV/AU-03	DPRS-N.10, Authentication of the user EN 300 175-5 [2]: 13.3.2, EN 300 444 [5]: 8.25 Initial state: Selected in PIXIT Verify that the IUT, after invocation, is able to perform the basic operation of the authentication of user procedure (PT has not stored ZAP value and service class information).
TP/FT/MM/BV/AU-04	DPRS-N.26, Authentication of FT EN 300 175-5 [2]: 13.3.3, EN 300 444 [5]: 8.23 Initial State: F-10 Verify that the IUT is able to perform the basic operation of the authentication of FT procedure.
TP/FT/MM/BV/AU-05	DPRS-N.16, ZAP EN 300 175-5 [2]: 13.3.3, EN 300 444 [5]: 8.23.2.1, figure 48 Initial State: F-00 Verify that the IUT rejects authentication of FT procedure if an authentication key is specified which is not supported by the FT.
TP/FT/MM/BV/AU-06	DPRS-N.16, ZAP EN 300 175-5 [2]: 13.3.3, EN 300 444 [5]: 8.23.2.1, figure 48 Initial state: Selected in PIXIT Verify that the IUT is capable to request storage of the DCK and successively use the stored DCK value for ciphering, when it is accepted by the PT.(PT has not stored ZAP value and service class information).
TP/FT/MM/TI-02	DPRS-N.9, Authentication of the PP EN 300 175-5 [2]: 13.3.1, EN 300 444 [5]: 8.24.2.2 Initial state: Specified in PIXIT Verify that the IUT is capable of completing the Authentication of PT procedure at a point in time 10 % before expiry of the timer F-<MM_auth.1>.
TP/FT/MM/TI-03	DPRS-N.10, Authentication of the user EN 300 175-5 [2]: 13.3.2, EN 300 444 [5]: 8.25.2.2. Initial state: Specified in PIXIT Verify that the IUT is capable of completing the Authentication of User procedure at a point in time 10 % before expiry of the timer F-<MM_auth.2>.

## 5.2.11 Location registration

DPRS-N.11, Location registration		
	Location registration	EN 300 444 [5]: 8.28
	Location update	EN 300 444 [5]: 8.29
	Terminal capability indication	EN 301 649 [6]: 12.3
DPRS-N.35, Detach		
	Detach	EN 300 824 [7]: 9.5
DPRS-N.36, Periodic location registration		
	Enhanced location registration	EN 300 824 [7]: 9.6
DPRS-N.24, Signalling of display characters		
	Display	EN 300 444 [5]: 8.16
	Terminal capability indication	EN 301 649 [6]: 12.3
DPRS-N.25, Display control characters		
	Display	EN 300 444 [5]: 8.16
	Terminal capability indication	EN 301 649 [6]: 12.3

TP/FT/MM/BV/LO-01	DPRS-N.11, Location registration EN 300 175-5 [2]: 13.4.1, EN 300 444 [5]: 8.28, figure 53 Initial state: F-00 Verify that the IUT is able to perform the basic operation of the location registration procedure, requested with an International Portable User Identity (IPUI), when broadcast attributes bit a38 was set to 1, and still is 1.
TP/FT/MM/BV/LO-02	DPRS-N.11, Location registration EN 300 175-5 [2]: 13.4.1, EN 300 444 [5]: 8.28.2.1, figure 54 Initial state: F-00 Verify that the IUT sends back a {LOCATE_REJECT} message, after receiving a {LOCATE_REQUEST} message containing a portable identity on which it does not have a subscription record (IPUI is unknown), when broadcast attributes bit a38 was set to 1, and still is 1.
TP/FT/MM/BV/LO-03	DPRS-N.11, Location registration EN 300 175-5 [2]: 13.4.1, EN 300 444 [5]: 8.28, figure 53 Initial state: F-00 Verify that the IUT is able to perform the basic operation of the location registration procedure, requested with an IPUI, while the IUT performs a TPUI assignment in the {LOCATE_ACCEPT} message, when broadcast attributes bit a38 was set to 1, and still is 1.
TP/FT/MM/BV/LO-05	DPRS-N.11, Location registration EN 300 175-5 [2], 13.4.3, EN 300 444 [5]: 8.29 Initial state: Specified in PIXIT Verify that the IUT, after invocation, is able to perform the basic operation of the FT initiated parameter retrieval procedure as Part of the location update procedure, when broadcast attributes bit a38 was set to 1, and still is 1 and the PT starts the location registration procedure upon receipt of the first {MM-INFO-SUGGEST} message.
TP/FT/MM/BV/LO-06	DPRS-N.11, Location registration EN 300 175-5 [2]: 13.4.3, EN 300 444 [5]: 8.29 Initial state: F-00 Verify that the IUT is able to perform the basic operation of the location registration procedure, requested with an IPUI, when broadcast attributes bit a38 was set to 1 during the locking of the IUT, and when it was changed to 0 afterward. (see note)
TP/FT/MM/BV/LO-07	DPRS-N.11, Location registration EN 300 175-5 [2]: 13.4.3, EN 300 444 [5]: 8.29 Initial state: Specified in PIXIT Verify that the IUT, after invocation, is able to perform the basic operation of the FT initiated parameter retrieval procedure as Part of the location update procedure, when broadcast attributes bit a38 was set to 1, and still is 1 and the PT starts the location registration procedure upon receipt of the second (MM-INFO-SUGGEST) message.
TP/FT/MM/BV/LO-50	DPRS-N.35, Detach EN 300 824 [7]: 9.5, table 12 Initial state: F-00 Verify that the IUT does not attempt to set up an incoming call to the portable after receipt of a DETACH message.
TP/FT/MM/BV/LO-51	DPRS-N.36, Periodic location registration EN 300 824 [7]: 9.6, table 13 Initial state: F-00 Verify that the IUT(FP) is able to transmit a LOCATE-ACCEPT message indicating <Lock limits> and <Time limits> within a <<DURATION>> information element.
TP/FT/MM/TI-07	DPRS-N.11, Location registration EN 300 175-5 [2]: 13.2.2, EN 300 444 [5]: 8.28 Initial state: F-00 Verify that the IUT, when during the location registration procedure with TPUI assignment, the timer F-<MM_ident.1> expires after the defined time, aborts the procedure, and thus allows a new location registration procedure to proceed.
NOTE:	The phrase "bit a38 was set to 1" means: The bit a38 had the value of 1 during the time the PT locked to the IUT.



## 5.2.12 Access rights

DPRS-N.14, Service class indication/assignment		
	Obtaining access rights	EN 300 444 [5]: 8.30
	Authentication of PT	EN 300 444 [5]: 8.24
DPRS-N.18, Subscription registration user procedure on-air		
	Obtaining access rights	EN 300 444 [5]: 8.30
	Terminal capability indication	EN 301 649 [6]: 12.3
DPRS-N.37, On-air modification of user parameters		
	On-air modification of user parameters	EN 300 824 [7]: 9.8
	FT authentication	EN 300 444 [5]: 8.23
DPRS-N.20, Terminate access rights FT initiated		
	FT terminating access rights	EN 300 444 [5]: 8.31
	Authentication of FT	EN 300 444 [5]: 8.23

TP/FT/MM/BV//AR-01	DPRS-N.14, Service class indication/assignment EN 300 175-5 [2]: 13.5.1, EN 300 444 [5]: 8.30 Initial state: No access rights. Bit a44 shall be set in the IUT Verify that the IUT is able to perform the basic operation of the obtain access rights procedure, when the LT sends in the <<AUTH_TYPE>> information element the auth_key_type "AC", and the IUT uses Authentication Code (AC) for authentication. The IUT shall include the whole Portable Access Rights Key (PARK).
TP/FT/MM/BV//AR-02	DPRS-N.14, Service class indication/assignment EN 300 175-5 [2]: 13.5.1, EN 300 444 [5]: 8.30, table 57 Initial state: No access rights. Bit a44 shall be set in the IUT Verify that the IUT is able to assign service class information as Part of the basic obtaining access rights procedure.
TP/FT/MM/BV//AR-03	DPRS-N.20, Terminate access rights FT initiated EN 300 175-5 [2]: 13.5.2, EN 300 444 [5]: 8.31.2.2 Initial state: Specified in PIXIT Verify that the IUT, after invocation, is able to perform the basic operation of the FT initiated terminate access rights procedure, when the LT successfully authenticates the IUT.
TP/FT/MM/BV//AR-06	DPRS-N.14, Service class indication/assignment EN 300 175-5 [2]: 13.5.1, EN 300 444 [5]: 8.30 Initial state: No access rights. Bit a44 has to be set in the IUT Verify that the IUT is able to perform the basic operation of the obtain access rights procedure, when the LT sends in the <<AUTH_TYPE>> information element the auth_key_type "UAK", and the IUT uses the User Authentication Key (UAK) for authentication. The IUT shall include the whole PARK.
TP/FT/MM/BV//AR-07	DPRS-N.14, Service class indication/assignment EN 300 175-5 [2]: 13.5.1, EN 300 444 [5]: 8.30, table 57 Initial state: No access rights. Bit a44 has to be set in the IUT Verify that the IUT is able to assign zap field as Part of the basic obtaining access rights procedure.
TP/FT/MM/BV//AR-50	DPRS-N.37, On-air modification of user parameters EN 300 824 [7]: 9.8, table 18 Initial state: T-00 Verify that the IUT is able to successfully perform the On-air modification of user parameters procedure.
TP/FT/MM/TI-04	DPRS-N.20, Terminate access rights FT initiated EN 300 175-5 [2]: 13.5.2, EN 300 444 [5]: 8.31.2.2 Initial state: F-00 Verify that the IUT is capable of completing the FT Termination of access rights procedure at a point in time 10 % before expiry of the timer F-<MM_access.2>.

### 5.2.13 On air key allocation

DPRS-N.12, On air key allocation		
	Key allocation	EN 300 444 [5]: 8.32
TP/FT/MM/BV/KA-01	DPRS-N.12, On air key allocation EN 300 175-5 [2]: 13.6, EN 300 444 [5]: 8.32 Initial state: Specified in PIXIT Verify that the IUT, after invocation, is able to perform the basic operation of the key allocation procedure.	
TP/FT/MM/BV/KA-02	DPRS-N.12, On air key allocation EN 300 175-5 [2]: 13.6, EN 300 444 [5]: 8.32.2.4, figure 63 Initial state: Specified in PIXIT Verify that the IUT, after invocation of the key allocation procedure, if the authentication of PT as Part of this procedure fails, returns an {AUTH-REJECT} message.	
TP/FT/MM/TI-05	DPRS-N.12, On air key allocation EN 300 175-5 [2]: 13.6, EN 300 444 [5]: 8.32.2.1 Initial state: Specified in PIXIT Verify that the IUT is capable of completing the FT Key allocation procedure at a point in time 10 % before expiry of the timer F-<MM_key.1>.	

### 5.2.14 Encryption

DPRS-N.17, Encryption activation FT initiated		
	Cipher-switching initiated by FT	EN 301 649 [6]: 12.12
	Storing the DCK	EN 301 649 [6]: 12.10
DPRS-N.27, Encryption activation PT initiated		
	Cipher-switching initiated by PT	EN 301 649 [6]: 12.13
	Storing the DCK	EN 301 649 [6]: 12.10
DPRS-N.28, Encryption deactivation FT initiated		
	Cipher-switching initiated by FT	EN 301 649 [6]: 12.12
DPRS-N.29, Encryption deactivation PT initiated		
	Cipher-switching initiated by PT	EN 301 649 [6]: 12.13

TP/FT/MM/BV/CH-01	DPRS-N.27, Encryption activation PT initiated EN 300 175-5 [2]: 13.8, EN 300 444 [5]: 8.34 Initial state: F-00 Verify that the IUT is able to correctly perform the basic cipher switching procedure after the PT initiated cipher switching procedure requesting "cipher-on", while no ciphering is active.	
TP/FT/MM/BV/CH-02	DPRS-N.29, Encryption deactivation PT initiated EN 300 175-5 [2]: 13.8, EN 300 444 [5]: 8.34 Initial state: F-00 Verify that the IUT is able to correctly perform the basic cipher request procedure after the PT initiated cipher switching procedure requesting "cipher-off", while ciphering is active.	
TP/FT/MM/BV/CH-04	DPRS-N.28, Encryption deactivation FT initiated EN 300 175-5 [2]: 13.8, EN 300 444 [5]: 8.34 Initial state: Specified in PIXIT Verify that the IUT, after invocation, is able to perform the basic operation of FT initiated cipher switching procedure requesting "cipher-off", while ciphering is active.	
TP/FT/MM/BV/CH-05	DPRS-N.27, Encryption activation PT initiated EN 300 175-5 [2]: 13.8, EN 300 444 [5]: 8.34.2.1, figure 68 Initial state: F-00 Verify that the IUT rejects a cipher switching request from the PT when a {CIPHER-SUGGEST} message has been received, containing a not supported cipher key.	
TP/FT/MM/BV/CH-08	DPRS-N.17, Encryption activation FT initiated EN 300 175-7 [4]: 6.4.6, EN 300 444 [5]: 10.14 Initial state: Specified in PIXIT Check that the IUT releases the basic Connection when it cannot conclude the procedure to switch from clear mode to encrypt mode (FT initiated cipher-switching).	

TP/FT/MM/BV/CH-09	DPRS-N.27, Encryption activation PT initiated EN 300 175-7 [4]: 6.4.6, EN 300 444 [5]: 10.14 Initial state: F-00 Check that the IUT releases the Connection when it cannot conclude the procedure to switch from clear mode to encrypt mode (PT initiated cipher-switching).
TP/FT/MM/BV/CH-10	DPRS-N.27, Encryption activation PT initiated EN 300 175-7 [4]: 6.4.7, EN 300 444 [5]: 10.15 Initial state: F-00 Check that the IUT responds rightly to a PT initiated intercell bearer handover procedure when encryption is enabled (PT initiated cipher-switching).
TP/FT/MM/BV/CH-11	DPRS-N.27, Encryption activation PT initiated EN 300 175-7 [4]: 6.4.7, EN 300 444 [5]: 10.15 Initial state: F-00 Check that the IUT responds rightly to a PT initiated intracell bearer handover procedure when encryption is enabled (PT initiated cipher-switching).
TP/FT/MM/BV/CH-12	DPRS-N.27, Encryption activation PT initiated EN 300 175-7 [4]: 6.4.7, EN 300 444 [5]: 10.15 Initial state: Specified in PIXIT Check that the IUT responds rightly to a PT initiated intercell bearer handover procedure when encryption is enabled (PT initiated cipher-switching).
TP/FT/MM/BV/CH-13	DPRS-N.27, Encryption activation PT initiated EN 300 175-7 [4]: 6.4.6, EN 300 444 [5]: 10.14 Initial state: F-00 Check that the IUT releases the Connection when it cannot conclude the procedure to switch from encrypt mode to clear mode (PT initiated cipher-switching).
TP/FT/MM/BV/CH-14	DPRS-N.17, Encryption activation FT initiated EN 300 175-7 [4]: 6.4.7, EN 300 444 [5]: 10.15 Initial state: Specified in PIXIT Check that the IUT responds rightly to a PT initiated intracell bearer handover procedure when encryption is enabled (FT initiated cipher-switching).
TP/FT/MM/BV/CH-15	DPRS-N.17, Encryption activation FT initiated EN 300 175-5 [2]: 13.8, EN 300 444 [5]: 8.33 Initial state: Specified in PIXIT Verify that the IUT, after invocation, is able to perform the basic operation of FT initiated cipher switching procedure requesting "cipher-off", while ciphering is active.
TP/FT/MM/BV/CH-data01	DPRS-N.27, Encryption activation PT initiated EN 301 649 [6]: 12.13 Initial state: F-00 Verify that the IUT, that does not support ciphering, rejects a cipher switching request from the PT when a {CIPHER-SUGGEST} message has been received, by sending immediately a {CIPHER-REJECT} message.
TP/FT/MM/TI-06	DPRS-N.28, Encryption deactivation FT initiated EN 300 175-5 [2]: 13.8, EN 300 444 [5]: 8.34.2.2 Initial state: Specified in PIXIT Verify that the IUT is capable of completing the FT initiated cipher-switching procedure at a point in time 10 % before expiry of the timer F-<MM_cipher.2>.

## 5.2.15 DECT External handover

DPRS-N.33, DECT External handover		
	Handover candidate indication	EN 300 824 [7]: 9.1.1.1
	Handover candidate retrieval	EN 300 824 [7]: 9.1.1.2
	Target FP selection	EN 300 824 [7]: 9.1.2
	Handover reference indication	EN 300 824 [7]: 9.1.3.1
	Handover reference retrieval	EN 300 824 [7]: 9.1.3.2
	External handover call setup	EN 300 824 [7]: 9.1.4
	Ciphering procedure PT initiated	EN 300 824 [7]: 9.1.5.1
	Ciphering procedure FT initiated	EN 300 824 [7]: 9.1.5.2
	U-plane handling	EN 301 649 [6]: 12.21

TP/FT/CC/BV/CR-50	DPRS-N.33, DECT External handover EN 300 824 [7]: 9.1.4.2.2 Initial state: F-10 Verify that after completing the external handover call setup procedure, the IUT can successfully perform the PT initiated normal CC-release procedure.
TP/FT/CC/BV/CR-51	DPRS-N.33, DECT External handover EN 300 824 [7]: 9.1.4.2.2 Initial state: F-10 Verify that after completing the external handover call setup procedure, the IUT can successfully perform the FT initiated normal CC-release procedure.
TP/FT/CC/BV/HP-50	DPRS-N.33, DECT External handover EN 300 824 [7]: 9.1.1, table 6 Initial state: F-00 Verify that during the establishment of an outgoing call, the IUT transmits a valid <<Ext h/o indicator>> information element in a CC-message.
TP/FT/CC/BV/HP-51	DPRS-N.33, DECT External handover EN 300 824 [7]: 9.1.1, table 6 Initial state: F-00 Verify that during the establishment of an incoming call, the IUT transmits a valid <<Ext h/o indicator>> information element in a CC-message.
TP/FT/CC/BV/HP-52	DPRS-N.33, DECT External handover EN 300 824 [7]: 9.1.3, table 7 Initial state: F-00 Verify that during the establishment of an outgoing call, the IUT transmits a valid <<network parameter>> information element in a CC-message.
TP/FT/CC/BV/HP-53	DPRS-N.33, DECT External handover EN 300 824 [7]: 9.1.3, table 7 Initial state: F-00 Verify that during the establishment of an incoming call, the IUT transmits a valid <<network parameter>> information element in a CC-message.
TP/FT/CC/BV/HP-54	DPRS-N.33, DECT External handover EN 300 824 [7]: 9.1.4, table 7 Initial state: F-10 Verify that the IUT is able to perform the external handover call setup procedure and successfully establishes the U-plane on the new connection. The IUT has to provide <ext h/o ind> in the external handover call setup.
TP/FT/MM/BV/HP-50	DPRS-N.33, DECT External handover EN 300 824 [7]: 9.1.1.2 Initial state: F-00 Verify that the IUT responds with a valid MM_INFO-ACCEPT message to an MM-INFO-REQUEST message requesting "external handover parameters".
TP/FT/MM/BV/HP-51	DPRS-N.33, DECT External handover EN 300 824 [7]: 9.1.3.2, table 8 Initial state: F-00 Verify that the IUT responds with a valid MM_INFO-ACCEPT message to an MM-INFO-REQUEST message requesting "handover reference".
TP/FT/MM/BV/HP-52	DPRS-N.33, DECT External handover EN 300 824 [7]: 9.1.4, table 7 Initial state: F-10 Verify that after performing the external handover call setup procedure on a ciphered connection, the IUT is able to successfully perform the PT initiated ciphering procedure on the new connection.
TP/FT/MM/BV/HP-53	DPRS-N.33, DECT External handover EN 300 824 [7]: 9.1.4, table 7 Initial state: F-10 Verify that after performing the external handover call setup procedure on a ciphered connection, the IUT releases the new Connection if ciphering fails on the new connection.
TP/FT/MM/BV/HP-54	DPRS-N.33, DECT External handover EN 300 824 [7]: 9.1.4, table 7 Initial state: F-10 Verify that after performing the external handover call setup procedure, the IUT initiates and successfully performs the FT initiated ciphering procedure on the new connection.

## 5.2.16 Link control

DPRS-N.19, Link control		
	Indirect FT initiated link establishment	EN 301 649 [6]: 12.15, EN 300 444 [5]: 8.35
	Fast Paging	EN 301 649 [6]: 12.16
	Collective and group ringing	EN 301 649 [6]: 12.17
	Direct FT initiated link establishment	EN 301 649 [6]: 12.18
	Direct PT initiated link establishment	EN 300 444 [5]: 8.36
	Link release "normal"	EN 300 444 [5]: 8.37
	Link release "abnormal"	EN 300 444 [5]: 8.38
	Link release "maintain"	EN 300 444 [5]: 8.39
	Resume Paging	EN 301 649 [6]: 12.19

TP/FT/LC/BV/LE-01	DPRS-N.19, Link control EN 300 175-5 [2]: 14.2.1 - 14.2.3, EN 300 444 [5]: 8.35, figure 69 Initial state: F-00 Verify that the IUT is able to initiate the indirect normal paged FT-initiated link establishment procedure. IUT shall attempt fast set-up which shall be ignored by the LT; consequently the IUT shall attempt fast paging which shall be ignored by the LT; Lt shall accept the following-on normal paging.
TP/FT/LC/BV/LE-02	DPRS-N.19, Link control EN 300 175-5 [2]: 14.2.1 - 14.2.3, EN 300 444 [5]: 8.35.2.1, figure 70 Initial state: F-00 Verify that the IUT rejects the {LCE-PAGE-RESPONSE} with mismatching IPUI during indirect (paged) FT-initiated link establishment and releases the link.
TP/FT/LC/BV/LE-03	DPRS-N.19, Link control EN 300 175-5 [2]: 14.2.1 - 14.2.2, EN 300 444 [5]: 8.36 Initial state: F-00 Verify that the IUT is able to handle a PT initiated link establishment.
TP/FT/LC/BV/LE-data01	DPRS-N.19, Link control EN 300 175-5 [2]: 14.2.1 - 14.2.3, EN 300 444 [5]: 8.35, figure 69 Initial state: F-00 Verify that the IUT is able to initiate the indirect fast paged FT-initiated link establishment procedure. IUT shall attempt fast set-up which shall be ignored by the LT; consequently the IUT shall attempt fast paging which shall be accepted.
TP/FT/LC/BV/LE-data02	DPRS-N.19, Link control EN 300 175-5 [2]: 14.2.1 - 14.2.3, EN 300 444 [5]: 8.35, figure 69 Initial state: F-00 Verify that the IUT is able to initiate the indirect fast paged FT-initiated link establishment procedure. IUT shall attempt fast set-up which shall be ignored by the LT; consequently the IUT shall attempt fast paging which shall be accepted.
TP/FT/LC/BV/LE-data03	DPRS-N.19, Link control EN 301 649 [6]: 12.17 Initial state: T-00 Verify that the IUT is able correctly to perform collective ringing and can establish a call when the User responses to the ringing.
TP/FT/LC/BV/LR-01	DPRS-N.19, Link control EN 300 175-5 [2]: 14.2.7, EN 300 444 [5]: 8.37 Initial state: F-00 Verify that the IUT is able to perform a normal PT initiated link release.
TP/FT/LC/BV/LR-02	DPRS-N.19, Link control EN 300 175-5 [2]: 14.2.5, EN 300 444 [5]: 8.39 Initial state: F-00 Verify that the IUT is able to maintain the link for a specified time, before releasing it, after the termination of an MM procedure. No other entities are using the link.
TP/FT/LC/BV/LR-03	DPRS-N.19, Link control EN 300 175-5 [2]: 14.2.5, EN 300 444 [5]: 8.39 Initial state: F-10 Verify that the IUT is able to start the link release after the termination of a call.
TP/FT/LC/BV/LR-04	DPRS-N.19, Link control EN 300 175-5 [2]: 14.2.5, EN 300 444 [5]: 8.39 Initial state: F-10 Verify that the IUT is able to maintain the link for a specified time, before releasing it, after a CC-requested partial release has been agreed on, and no other entities are using the link.
TP/FT/LC/TI-02	DPRS-N.19, Link control EN 300 175-5 [2]: 14.2.5, EN 300 444 [5]: 8.39.1.1 Initial state: F-00 Verify that the IUT, after termination of an MM procedure, maintains the link for a period of <LCE.02>. The link shall be released in the period (<LCE_02> - 1 000) ms to 10 500 ms.
TP/FT/LC/BI-07	DPRS-N.19, Link control EN 300 175-5 [2]: 14.2, EN 300 444 [5]: 8.38 Initial state: F-10 Verify that the IUT, when the link fails during an active call, clears the call.

## 5.2.17 Message Waiting Indication

DPRS-N.34, Message Waiting Indication		
	Message waiting indication	EN 300 824 [7]: 9.7

TP/FT/IS/BV-50	DPRS-N.34, Message Waiting Indication EN 300 824 [7], 9.7 - 9.7.1, table 16 Initial state: F-00 Verify that the IUT as Part of a Message waiting indication activation procedure sends correctly a notification for message waiting.
TP/FT/IS/BV-51	DPRS-N.34, Message Waiting Indication EN 300 824 [7], 9.7 - 9.7.2, table 17 Initial state: F-00 Verify that the IUT as Part of a Message waiting indication deactivation procedure sends correctly a notification with <numberOfMessages> equal to zero.

## 5.2.18 Distributed communication

DPRS-A.1 Distributed communication		
	HyP (Distributed Communication)	EN 301 649 [6]: annex E

TP/FT/MM/BV/ID-data01	Distributed communication EN 300 175-5 [2]: 14.4 Initial state: F-00 Verify that the IUT performs properly the Temporary Identity Assign procedures assigning a CL TPUI.
TP/FT/CL/BV-01	Distributed communication EN 300 175-5 [2]: 12.3.1 Initial state: F-00 Verify that the IUT, after invocation, is able to send a CLMS-FIXED message.
TP/FT/CL/BV-02	Distributed communication EN 300 175-5 [2]: 14.2.1 - 14.2.3 Initial state: F-00 Verify that the IUT, after invocation, is able to send a CLMS-VARIABLE. message.
TP/FT/CL/BV-03	Distributed communication EN 300 175-5 [2]:.2.1 - 14.2.3 Initial state: F-00 Verify that the IUT is able to receive a CLMS-VARIABLE message.

## 5.2.19 MAC Suspend/Resume

<b>DPRS</b> MAC Suspend/Resume		
	MAC Suspend	EN 301 649 [6]: ??
	MAC Resume	EN 301 649 [6]: ??

TP/FT/CC/BV/SR-data01	<p><b>EN 301 649 [6]: 10.7.3, 10.7.4</b>  Initial state: F-00  Verify that the IUT is able to handle correctly the MAC suspend/resume procedure when the FT initiates the suspend and the FT initiates resume with normal paging. LT shall ignore other FT attempts (fast set-up and fast paging) and accept the normal paging.</p>
TP/FT/CC/BV/SR-data02	<p><b>EN 301 649 [6]: 10.7.3, 10.7.4</b>  Initial state: F-00  Verify that the IUT is able to handle correctly the MAC suspend/resume procedure when the FT initiates the suspend and the FT initiates resume with fast paging. LT shall ignore other FT attempts (fast set-up) and accept the fast paging.</p>
TP/FT/CC/BV/SR-data03	<p><b>EN 301 649 [6]: 10.7.3, 10.7.4</b>  Initial state: F-00  Verify that the IUT is able to handle correctly the MAC suspend/resume procedure when the FT initiates the suspend and the FT initiates resume with fast setup.</p>
TP/FT/CC/BV/SR-data04	<p><b>EN 301 649 [6]: 10.7.3, 10.7.4</b>  Initial state: F-00  Verify that the IUT is able to handle correctly at NWK layer the MAC suspend/resume procedure when the PT initiates the suspend and the FT initiates the resume with normal paging. LT shall ignore other FT attempts (fast set-up and fast paging) and accept the normal paging.</p>
TP/FT/CC/BV/SR-data05	<p><b>EN 301 649 [6]: 10.7.3, 10.7.4</b>  Initial state: F-00  Verify that the IUT is able to handle correctly at NWK layer the MAC suspend/resume procedure when the PT initiates the suspend and the FT initiates the resume with fast paging. LT shall ignore other FT attempts (fast set-up) and accept the fast paging.</p>
TP/FT/CC/BV/SR-data06	<p><b>EN 301 649 [6]: 10.7.3, 10.7.4</b>  Initial state: F-00  Verify that the IUT is able to handle correctly the MAC suspend/resume procedure when the PT initiates the suspend and the FT initiates resume with fast setup.</p>
TP/FT/CC/BV/SR-data07	<p><b>EN 301 649 [6]: 10.7.3, 10.7.4</b>  Initial state: F-00  Verify that the IUT is able to handle correctly the MAC suspend/resume procedure when the PT initiates the suspend and the PT initiates resume.</p>
TP/FT/CC/BV/SR-data08	<p><b>EN 301 649 [6]: 10.7.3, 10.7.4</b>  Initial state: F-00  Verify that the IUT is able to handle correctly the MAC suspend/resume procedure when the FT initiates the suspend and the PT initiates resume.</p>



## 5.3 Test purposes for PT part

### 5.3.1 TP presentation

Test purposes are presented by a logical grouping related to NWK features. The naming is in line with the test suite structure. Existing test purposes in the CI test case library are highlighted by a greyed name column.

### 5.3.2 Dynamic parameters allocation and NWK layer management

DPRS-N.38, Dynamic parameters allocation		
	Dynamic parameters allocation	EN 301 649 [6]: 12.11
DPRS-N.41, NWK layer management		
	Management of MM procedures	EN 301 649 [6]: 12.22
	Location registration initiation management	EN 300 444 [5]: 13.2
	Assigned individual TPUI management	EN 300 444 [5]: 13.4
	PMID management	EN 300 444 [5]: 13.5
	DCK management	EN 300 444 [5]: 13.6
	Broadcast attributes management	EN 301 649 [6]: 12.20
	Storage of subscription related data management	EN 301 649 [6]: 12.xx-
	U-plane handling	EN 301 649 [6]: 12.21

These two features are implicitly covered by the test purposes defined for all other NWK features.

### 5.3.3 SARI support

DPRS M.15 SARI support		
	Downlink broadcast	EN 300 175-3 [1]: 7.2.3.6

TP/PT/MM/BV/LO-10	M.15 SARI support EN 300 175-3 [1]: 11.3.2, EN 300 175-6 [3]: 5.6 Initial state: T-00 Verify that the IUT can correctly perform location registration and a following outgoing call when it uses SARI as the means to lock to the LT.
-------------------	--

### 5.3.4 Outgoing call

DPRS-N.1, Outgoing call		
	Outgoing call request	EN 301 649 [6]: 12.1
	Overlap sending	EN 300 444 [5]: 8.3
	Outgoing call proceeding	EN 300 444 [5]: 8.4
	Outgoing call confirmation	EN 300 444 [5]: 8.5
	Outgoing call connection	EN 300 444 [5]: 8.6
	Sending keypad information	EN 300 444 [5]: 8.10
DPRS-N.2, Off Hook		
	Outgoing call request	EN 300 444 [5]: 8.2
DPRS-N.3, On Hook (full release)		
	Normal call release	EN 300 444 [5]: 8.7
	Abnormal call release	EN 300 444 [5]: 8.8
DPRS-N.21, Partial release		
	Partial release	EN 300 444 [5]: 8.9

TP/PT/CC/BV/MP-data01	<p>DPRS-N.1, Outgoing call EN 300 444 [5]: 8.1, figure 1</p> <p>Initial state/Conditions: IUT is in idle_active - no subscription available. If such is found the test shall remove it. Test is valid only for IUT that can transmit dialling information in T-02, e.g. able to be connected to an external switched network as ISDN.</p> <p>Verify that the IUT is able after obtaining a valid subscription to perform an outgoing call through all CC-states using piecewise method to transfer dialling information in state T-02 performing resources management, data transfer and proper released by the IUT of the call. The LT(FT) accepts the suggested in the {CC-SETUP} lower layer resources.</p>
<p><b>Explicitly testing:</b></p> <ul style="list-style-type: none"> <li>- Obtain access rights procedure;</li> <li>- Key allocation procedures;</li> <li>- Location registration procedure;</li> <li>- PT authentication procedure;</li> <li>- Store DCK procedure;</li> <li>- Outgoing call establishment;</li> <li>- LCE Link establishment;</li> <li>- CC-transitions;</li> <li>- FT initiating Ciphering;</li> <li>- Service negotiation (suggested characteristics accepted from the LT);</li> <li>- U-plane connection;</li> <li>- U-plane transfer;</li> <li>- MAC suspend/resume;</li> <li>- Service change;</li> <li>- PT initiated Call release.</li> </ul> <p><b>Expected behaviour:</b></p> <p><u>Pre call establishment</u></p> <p>The IUT(PT) shall initiate Obtain access rights procedure; the LT (FT) shall interrupt it with a Key allocation procedure; When the Obtain access rights is accomplished successfully the IUT shall perform a Location Registration procedure - LT shall assign TPUI; LT shall interrupt the Location registration with a PT authentication to verify the keys and to request DCK;</p> <p><u>Call establishment</u></p> <p>IUT shall be requested to start an Outgoing call; IUT shall initiate link establishment; Call setup shall occur - LT answers to {CC-SETUP} with a {CC-SETUP-ACK}, followed by a {CC-CALL-PROC}, a {CC-ALERTING} and a {CC-CONNECT} - IUT starts digits transmission in T-02; Lower layer resources negotiation is performed as the information included from the IUT will be in the CC-SETUP, and from LT in CC-SETUP-ACK accepting the suggestion; LT shall initiate ciphering in T-01, if it is accepted or if it is rejected and the IUT does not support ciphering the test shall go on - otherwise it shall fail;</p> <p><u>Data transmission (in T-10)</u></p> <p>Establishment of all necessary resources at MAC shall be verified; LT shall transmit a relatively big amount of data which require maximum used of the resources; LT shall request MAC suspend of the link on completion of the data transfer; if link is suspended after some time LT shall request MAC resume (fast setup, fast paging, and normal paging shall be performed until one succeeds); LT shall transmit a small amount of data that does not require full capacity and shall request Service change reducing the max. number of bearers (LT Master); new MAC resources set shall be verified; LT shall transmit a small amount of data that does not require full capacity;</p> <p><u>Call release</u></p> <p>IUT shall be requested to release normally the call.</p>	
TP/PT/CC/BV/MP-data02	<p>DPRS-N.1, Outgoing call EN 300 444 [5]: 8.1, figure 2</p> <p>Initial state/Conditions: IUT is in idle_active - no subscription available. If such is found the test shall remove it.</p> <p>Verify that the IUT is able after obtaining a valid subscription to perform a CC-state transition from the T-00 state to T-10 state via T-01 for an outgoing normal call set-up using piecewise method to transfer dialling information in state T-10 performing resources management, data transfer and proper released by the IUT of the call. The LT(FT) accepts the suggested in the {CC-SETUP} lower layer resources.</p>
<p><b>Explicitly testing/ Expected behaviour:</b></p> <p>See TP/PT/CC/BV/OC-data01 - only difference is the CC-transitions directly from T-01 to T-10.</p>	

TP/PT/CC/BV/CR-01	DPRS-N.3, On Hook (full release) EN 300 175-5 [2]: 9.5.1, EN 300 444 [5]: 8.7 Initial state: T-02 Verify that the IUT is able to process a FT initiated normal release.
TP/PT/CC/BV/CR-05	DPRS-N.3, On Hook (full release) EN 300 175-5 [2]: 9.5.1, EN 300 444 [5]: 8.7 Initial state: T-10 Verify that the IUT is able to process a FT initiated normal release.
TP/PT/CC/BV/CR-06	DPRS-N.3, On Hook (full release) EN 300 175-5 [2]: 9.5.1, EN 300 444 [5]: 8.7 Initial state: T-10 Verify that the IUT is able to process an IUT initiated normal release.
TP/PT/CC/BV/CR-07	DPRS-N.3, On Hook (full release) EN 300 175-5 [2]: 9.5.2, EN 300 444 [5]: 8.8 Initial state: T-01 Verify that the IUT is able to process a FT initiated abnormal release.
TP/PT/CC/BV/CR-09	DPRS-N.3, On Hook (full release) EN 300 175-5 [2]: 9.5.2, EN 300 444 [5]: 8.8 Initial state: T-10 Verify that the IUT is able to process a FT initiated abnormal release.
TP/PT/CC/BV/CR-10	DPRS-N.21, Partial release EN 300 175-5 [2]: 14.2.7, EN 300 444 [5]: 8.9 Initial state: T-10 Verify that the IUT is able to process a FT initiated partial release.
TP/PT/CC/BV/CR-11	DPRS-N.21, Partial release EN 300 175-5 [2]: 14.2.7, EN 300 444 [5]: 8.9 Initial state: T-10 Verify that the IUT is able to process an IUT initiated partial release.
TP/PT/CC/TI-01	DPRS-N.3, On Hook (full release) EN 300 175-5 [2]: 9.5.1, EN 300 444 [5]: 8.7.2.3 Initial state: T-19 Verify that the IUT, after having started timer P-<CC.02>, sends a {CC-RELEASE-COM} message when the timer expires after the defined time. The {CC-RELEASE-COM} message should arrive within the allowed margin time of $\pm 5$ %.
TP/PT/CC/TI-02	DPRS-N.1, Outgoing call EN 300 175-5 [2]: 9.3.2.1, EN 300 444 [5]: 8.2.2.1 Initial state: T-01 Verify that the IUT, after having started timer P-<CC.03>, sends a {CC-RELEASE-COM} message when the timer expires after the defined time. The {CC-RELEASE-COM} message should arrive within the allowed margin time of $\pm 5$ %.
TP/PT/CC/TI-03	DPRS-N.1, Outgoing call EN 300 175-5 [2]: 9.3.2.1, EN 300 444 [5]: 8.2.1.1 Initial state: T-01 Verify that the IUT is able to restart timer P-<CC.03>. on receipt of a {CC-NOTIFY} message, sent by the FT.
TP/PT/CC/BO-02	DPRS-N.3, On Hook (full release) EN 300 175-5 [2]: 9.5.3, EN 300 444 [5]: 8.7.2.1, figure 21. Initial state: T-19 Verify that the IUT is able to react correctly on a release collision, in the sense that on the reception of a {CC-RELEASE} message in state F-19, no {CC-RELEASE-COM} message is sent back, and the call is cleared.

### 5.3.5 Service Negotiation and In call service change

DPRS-N.39, Service Negotiation		
	Call Resources/Parameters negotiation	EN 301 649 [6]: 12.5
DPRS-N.40, In call service change		
	Bandwidth Change	EN 301 649 [6]: 12.6
	Connection Reversal	EN 301 649 [6]: 12.7
	Service re-routing	EN 301 649 [6]: 12.8
	IWU-attributes change	EN 301 649 [6]: 12.9

TP/PT/CC/BV/SN-data01	<p>DPRS-N.39, Service Negotiation EN 300 444 [5]: 8.1, figure 2 Initial state/Conditions: T-00, subscription available (if not the test will request it). Verify that the IUT is able to perform a CC-state transition from the T-00 state to T-10 state via T-01 for an outgoing normal call set-up using piecewise method to transfer dialling information in state T-10. The LT suggest different, lower than the requested by the IUT values of "Target bearers" in the &lt;&lt;Connection attributes&gt;&gt;. Before accepting the call the LT initiates ciphering.</p>
TP/PT/CC/BV/SN-data02	<p>DPRS-N.39, Service Negotiation EN 300 444 [5]: 8.1, figure 2 Initial state/Conditions: T-00, subscription available (if not the test will request it). Verify that the IUT is able to perform a CC-state transition from the T-00 state to T-10 state via T-01 for an outgoing normal call set-up using piecewise method to transfer dialling information in state T-10. The LT suggest different, lower than the requested by the IUT values of &lt;MAC packet life time&gt; in the &lt;&lt;Connection attributes&gt;&gt;. Before accepting the call the LT initiates ciphering.</p>
TP/PT/CC/BV/SN-data03	<p>DPRS-N.39, Service Negotiation EN 300 444 [5]: 8.1, figure 2 Initial state/Conditions: T-00, subscription available (if not the test will request it). Verify that the IUT is able to perform a CC-state transition from the T-00 state to T-10 state via T-01 for an outgoing normal call set-up using piecewise method to transfer dialling information in state T-10. The LT suggest different, lower than the requested by the IUT values of the &lt;&lt;Window size&gt;&gt;. Before accepting the call the LT initiates ciphering.</p>
TP/PT/CC/BV/SN-data04	<p>DPRS-N.39, Service Negotiation EN 300 444 [5]: 8.1, figure 2 Initial state/Conditions: T-00, subscription available (if not the test will request it). Verify that the IUT is able to perform a CC-state transition from the T-00 state to T-10 state via T-01 for an outgoing normal call set-up using piecewise method to transfer dialling information in state T-10. The LT suggest different values of the &lt;&lt;IWU attributes&gt;&gt;. Before accepting the call the LT initiates ciphering.</p>

TP/PT/CC/BV/SC-data01	DPRS-N.40, In call service change EN 301 649 [6]: 12.9 Initial state/Conditions: T-10, subscription available (if not the test will request it). Verify that the IUT is able to perform correctly the Service change procedure when initiated by the LT(FT); initiating side is the Master. The LT suggest different values of the <<IWU attributes>>. Before accepting the call the LT initiates ciphering.
TP/PT/CC/BV/SC-data02	DPRS-N.40, In call service change EN 301 649 [6]: 12.9 Initial state/Conditions: T-10, subscription available (if not the test will request it). Verify that the IUT is able to perform correctly the Service change procedure when initiated by the LT(FT); receiving side is the Master. The LT suggest different values of the <<IWU attributes>>. Before accepting the call the LT initiates ciphering.
TP/PT/CC/BV/SC-data03	DPRS-N.40, In call service change EN 301 649 [6]: 12.6 Initial state/Conditions: T-10, subscription available (if not the test will request it). Verify that the IUT is able to perform correctly the Service change procedure when initiated by the LT(FT); initiating side is the Master. The LT suggests "bandwidth change" and different values of the <<Connection attributes>>. Before accepting the call the LT initiates ciphering.
TP/PT/CC/BV/SC-data04	DPRS-N.40, In call service change EN 301 649 [6]: 12.6 Initial state/Conditions: T-10, subscription is assumed available but if not the test will request it. Verify that the IUT is able to perform correctly the Service change procedure when initiated by the LT(FT); receiving side is the Master. The LT suggests "bandwidth change" and different values of the <<Connection attributes>>. Before accepting the call the LT initiates ciphering.
TP/PT/CC/BV/SC-data05	DPRS-N.40, In call service change EN 301 649 [6]: 12.7 Initial state/Conditions: T-10, subscription is assumed available but if not the test will request it. Verify that the IUT is able to perform correctly the Service change procedure when initiated by the LT(FT); initiating side is the Master. The LT suggests "Connection reversal" and different values of the <<Connection attributes>>. Before accepting the call the LT initiates ciphering.
TP/PT/CC/BV/SC-data06	DPRS-N.40, In call service change EN 301 649 [6]: 12.7 Initial state/Conditions: T-10, subscription is assumed available but if not the test will request it. Verify that the IUT is able to perform correctly the Service change procedure when initiated by the LT(FT); receiving side is the Master. The LT suggests "Connection reversal" and different values of the <<Connection attributes>>. Before accepting the call the LT initiates ciphering.
<b>Expected behaviour:</b> LT Establishes an Incoming call as Lower layer resources negotiation shall be accomplished with information included from the LT in CC-SETUP, and from IUT in CC-ALERTING; in T-07 FT shall authenticate the PT with "Store DCK" enabled and shall requests Ciphering - if PT does not support it shall reject; when in T-10 the U-plane transmission shall be checked; FT shall initiate the Service change procedure; Resource allocation at MAC shall be initiated by the Master as specified during the procedure; When accomplished the U-plane shall be checked again; Normal Release of the call shall be requested from the LT.	

TP/PT/CC/BV/SC-data07	<p>DPRS-N.40, In call service change EN 301 649 [6]: 12.9 Initial state/Conditions: T-10, subscription available (if not the test will request it). <u>For IUT that can invoke such service change.</u> Verify that the IUT is able to perform correctly the Service change procedure when initiated by the IUT(PT); Master side specified by the IUT. The IUT suggest different values of the &lt;&lt;IWU attributes&gt;&gt;. Before accepting the call the LT initiates ciphering.</p>
TP/PT/CC/BV/SC-data08	<p>DPRS-N.40, In call service change EN 301 649 [6]: 12.6 Initial state/Conditions: T-10, subscription available (if not the test will request it). <u>For IUT that can invoke such service change.</u> Verify that the IUT is able to perform correctly the Service change procedure when initiated by the IUT(PT); Master side specified by the IUT. The IUT suggests "bandwidth change" and different values of the &lt;&lt;Connection attributes&gt;&gt;. Before accepting the call the LT initiates ciphering.</p>
TP/PT/CC/BV/SC-data09	<p>DPRS-N.40, In call service change EN 301 649 [6]: 12.7 Initial state/Conditions: T-10, subscription available (if not the test will request it). <u>For IUT that can invoke such service change.</u> Verify that the IUT is able to perform correctly the Service change procedure when initiated by the IUT(PT); Master side specified by the IUT. The IUT suggests "Connection reversal" and different values of the &lt;&lt;Connection attributes&gt;&gt;. Before accepting the call the LT initiates ciphering.</p>
<p><b>Expected behaviour:</b> IUT shall establish an outgoing call as Lower layer resources negotiation shall be accomplished with information included from the IUT in CC-SETUP, and from LT in CC-CONNECT; in T-01 FT shall authenticate the PT with "Store DCK" enabled and shall requests Ciphering - if PT does not support it shall reject; when in T-10 the U-plane transmission shall be checked; IUT shall be requested to initiate the Service change procedure; Resource allocation at MAC shall be initiated by the Master as specified during the procedure; When accomplished the U-plane shall be checked again; Normal Release of the call shall be requested from the LT.</p>	

### 5.3.6 Sending keypad information

DPRS-N.4, Dialed digits (basic) DPRS-N.5, Register recall DPRS-N.6, Go to DTMF signalling (defined tone length) DPRS-N.7, Pause (dialling pause) DPRS-N.22, Go to DTMF (infinite tone length) DPRS-N.23, Go to Pulse		
	Sending keypad information	EN 300 444 [5]: 8.10

TP/PT/CC/BV/CI-02	DPRS-N.23, Go to Pulse EN 300 175-5 [2]: 9.3.1.5, EN 300 444 [5]: 8.10, table 20 Initial state: T-02 Verify that the IUT, after the user has invoked pulse (decadic) dialling, sends a {CC-INFO} message with a <<MULTI-KEYPAD>> information element containing keypad-info '12H' (goto pulse).
TP/PT/CC/BV/CI-05	DPRS-N.7, Pause (dialling pause) EN 300 175-5 [2]: 9.3.1.5, EN 300 444 [5]: 8.10, table 20 Initial state: T-10 Verify that the IUT, after the user has invoked dialling pause, sends a {CC-INFO} message with a <<MULTI-KEYPAD>> information element containing keypad-info '05H' (dialling pause).
TP/PT/CC/BV/CI-06	DPRS-N.6, Go to DTMF signalling (defined tone length) EN 300 175-5 [2]: 9.3.1.5, EN 300 444 [5]: 8.10, table 20 Initial state: T-02 Verify that the IUT, after the user has invoked DTMF dialling with defined tone length, sends a {CC-INFO} message with a <<MULTI-KEYPAD>> information element containing keypad-info '14H' (goto DTMF, defined tone length).
TP/PT/CC/BV/CI-09	DPRS-N.22, Go to DTMF (infinite tone length) EN 300 175-5 [2]: 9.3.1.5, EN 300 444 [5]: 8.10, table 20 Initial state: T-10 Verify that the IUT, after the user has invoked DTMF dialling with defined tone length, sends a {CC-INFO} message with a <<MULTI-KEYPAD>> information element containing keypad-info '16H' (goto DTMF, infinite tone length).
TP/PT/CC/BV/CI-10	DPRS-N.4, Dialed digits (basic) EN 300 175-5 [2]: 9.3.1.5, EN 300 444 [5]: 8.10, table 20 Initial state: T-02 Verify that the IUT, after the user has invoked the sending of the basic digits (0-9, star, hash mark), sends one or more {CC-INFO} messages with <<MULTI-KEYPAD>> information elements containing the basic digits.
TP/PT/CC/BV/CI-14	DPRS-N.5, Register recall EN 300 175-5 [2]: 9.3.1.5, EN 300 444 [5]: 8.10, table 20 Initial state: T-10 Verify that the IUT, after invocation of 'register recall', is able to activate the feature register recall in a {CC-INFO} message.

### 5.3.7 Incoming call

DPRS-N.2, Off Hook		
	Incoming call connection	EN 300 444 [5]: 8.15
DPRS-N.8, Incoming call		
	Incoming call request	EN 301 649 [6]: 12.2
	Incoming call confirmation	EN 300 444 [5]: 8.13
	Incoming call connection	EN 300 444 [5]: 8.15
DPRS-N.15, Alerting		
	PT alerting	EN 300 444 [5]: 8.14
DPRS-N.30, Calling Line Identification Presentation (CLIP)		
	Incoming call request	EN 300 444 [5]: 8.12

TP/PT/CC/BV/MP-data03	<p>DPRS-N.8, Incoming call EN 301 649 [6]: 12.2, EN 300 444 [5]: 8.11, figure 28 Initial state: T-00 Verify that the IUT is able to perform an incoming call via the states T-06, T-07 and T-08 to the state T-10 10 performing resources management, data transfer and proper released by the LT of the call. IUT shall handle properly the service negotiation. LT sends &lt;&lt;SIGNAL&gt;&gt; in the {CC-INFO} message.</p>
<p><b>Implicitly testing:</b></p> <ul style="list-style-type: none"> <li>- LCE Link establishment (FT direct or indirect);</li> <li>- Incoming Call establishment trough all CC-state;</li> <li>- PT authentication procedure;</li> <li>- Store DCK procedure;</li> <li>- FT initiating Ciphering;</li> <li>- Service negotiation (suggested characteristics accepted or not by IUT);</li> <li>- U-plane connection;</li> <li>- U-plane transfer;</li> <li>- MAC suspend/resume;</li> <li>- Service change;</li> <li>- FT initiated Call release.</li> </ul> <p><b>Expected behaviour:</b></p> <p><u>Pre call establishment</u> Subscription should be available if not shall be obtained as in the outgoing call cases: The IUT(PT) shall initiate Obtain access rights procedure; the LT (FT) shall interrupt it with a Key allocation procedure; When the Obtain access rights is accomplished successfully the IUT shall perform a Location Registration procedure - LT shall assign TPUI; LT shall interrupt the Location registration with a PT authentication to verify the keys and to request DCK;</p> <p><u>Call establishment</u> LT(FT) shall try Direct link establishment - if it fails it shall try Fast Paging - if it fails shall try normal Paging (whatever IUT(PT) answers and based on the set-up capability indicated during location registration); When link established Incoming Call setup shall occur; Lower layer resources negotiation is performed as the information included from the LT will be in the CC-SETUP, and from IUT in CC-ALERTING - IUT may but need not accepting the suggestion; LT shall initiate ciphering in T-07 preceded by a PT authentication with "store DCK", if ciphering is accepted, or, if it is rejected and the IUT does not support ciphering the test shall go on - otherwise it shall fail;</p> <p><u>Data transmission (in T-10)</u> As in the outgoing call cases: Establishment of all necessary resources at MAC shall be verified; LT shall transmit a relatively big amount of data which require maximum used of the resources; LT shall request MAC suspend of the link on completion of the data transfer; if link is suspended after some time LT shall request MAC resume (fast setup, fast paging, and normal paging shall be performed until one succeeds); LT shall transmit a small amount of data that does not require full capacity and shall request Service change reducing the max. number of bearers (LT Master); new MAC resources set shall be verified; LT shall transmit a small amount of data that does not require full capacity;</p> <p><u>Call release</u> LT shall be requested normal call release.</p>	



TP/PT/CC/BV/MP-data04	DPRS-N.8, Incoming call EN 301 649 [6]: 12.2, EN 300 444 [5]: 8.11, figure 28 Initial state: T-00 Verify that the IUT is able to perform an incoming call via the states T-06, T-07 and T-08 to the state T-10 performing resources management, data transfer and proper released by the LT of the call. IUT shall handle properly the service negotiation. LT sends <<SIGNAL>> in the {CC-SETUP} message.
<b>Explicitly testing/ Expected behaviour:</b> See TP/PT/CC/BV/MP-data03 - only difference is the where the <SIGNAL> information element.	

TP/PT/CC/BV/RS-01	DPRS-N.30, Calling Line Identification Presentation (CLIP) EN 300 175-5 [2]: 10.3, EN 300 444 [5]: 8.12, EN 300 824 [7]: 7.7, table 3 Initial state: T-00 Verify that the IUT shows the calling party number correctly on receipt of calling party number indication before accepting a call.
TP/PT/CC/TI-04	DPRS-N.8, Incoming call EN 300 175-5 [2]: 9.3.2.8, EN 300 444 [5]: 8.15.2.3 Initial state: T-08 Verify that the IUT, after having started timer P-<CC.05>, releases the call using the normal procedure when the timer expires after the defined time. The {CC-RELEASE} message should arrive within the allowed margin time of $\pm 5\%$ .

### 5.3.8 Internal call and Service call

DPRS-N.31, Internal call		
	Internal call set-up	EN 300 444 [5]: 8.18
	Internal call keypad	EN 301 649 [6]: 12.4
DPRS-N.32, Service call		
	Service call set-up	EN 300 444 [5]: 8.20
	Service call keypad	EN 300 444 [5]: 8.21

TP/PT/CC/BV/MP-data05	DPRS-N.31, Internal call EN 300 444 [5], 8.18, table 30 Initial state: T-00 Verify that the IUT, after the user has invoked an Internal call, is able to perform an Internal call set-up trough all CC-states using piecewise method to transfer dialling information in state T-02 performing resources management, data transfer and proper released by the IUT of the call. The LT(FT) accepts the suggested in the {CC-SETUP} lower layer resources.
<b>Explicitly testing/ Expected behaviour:</b> See TP/PT/CC/BV/MP-data01 - only difference is the content of the <<basic service>> now indicating "Internal Call" and the IUT should be subscribed beforehand.	

TP/PT/CC/BV/MP-data06	DPRS-N.31, Internal call EN 300 444 [5], 8.18, table 31 Initial state: T-10 Verify that the IUT is able to perform a CC-state transition from the T-00 state to T-10 state via T-01 and request an Internal call via a {CC-INFO} message sent in T-10 using piecewise method to transfer dialling information in state T-10 performing resources management, data transfer and proper released by the IUT of the call. The LT(FT) accepts the suggested in the {CC-SETUP} lower layer resources, the {CC-INFO} shall not attempt to change them.
<b>Explicitly testing/ Expected behaviour:</b> See TP/PT/CC/BV/MP-data02 - only differences are: the IUT should be subscribed beforehand, in T-10 before sending dialled digits {CC-INFO} <<Multi-keypad>> "Internal Call" shall be sent by the IUT.	

### 5.3.9 Identification of PP and Identity Assignment

DPRS-N.13, Identification of PP		
	Identification of PT	EN 300 444 [5]: 8.22
DPRS-N.42, Identity Assignment		
	Temporary Identity Assign	EN 301 649 [6]: 12.14

TP/PT/MM/BV/ID-01	DPRS-N.13, Identification of PP EN 300 175-5 [2]: 13.2.1, EN 300 444 [5]: 8.22 Initial state: T-00 Verify that the IUT, on receipt of an {IDENTITY-REQUEST} message specifying the International Portable User Identity (IPUI), returns an {IDENTITY-REPLY} message with the IPUI.
TP/PT/MM/BV/ID-02	DPRS-N.13, Identification of PP EN 300 175-5 [2]: 13.2.1, EN 300 444 [5]: 8.22.2.1 Initial state: T-00 Verify that the IUT, on receipt of an {IDENTITY-REQUEST} message specifying an unavailable identity type, returns an {IDENTITY-REPLY} message without identity information elements thereby indicating reject.
TP/PT/MM/BV/ID-08	DPRS-N.13, Identification of PP EN 300 175-5 [2]: 13.2.1, EN 300 444 [5]: 8.22 Initial state: T-00 Verify that the IUT, on receipt of an {IDENTITY-REQUEST} message specifying the PARK, returns an {IDENTITY-REPLY} message with the PARK.
TP/PT/MM/BV/ID-data02	DPRS-N.42, Identity Assignment EN 301 649 [6]: 12.14 Initial state: T-00 Verify that the IUT on receipt of a {TEMPORARY-IDENTITY-ASSIGN-REQ} message assigning a group TPUI accepts the assignment.

### 5.3.10 Authentication

DPRS-N.9, Authentication of the PP		
	Authentication of PT	EN 300 444 [5]: 8.24
DPRS-N.10, Authentication of the user		
	Authentication of user	EN 300 444 [5]: 8.25
DPRS-N.16, ZAP		
	Obtaining access rights	EN 300 444 [5]: 8.30
	Incrementing the ZAP value	EN 300 444 [5]: 8.26
DPRS-N.26, Authentication of FT		
	Authentication of FT	EN 300 444 [5]: 8.23

TP/PT/MM/BV/AU-01	<p>DPRS-N.9, Authentication of the PP EN 300 175-5 [2]: 13.3.1, EN 300 444 [5]: 8.24 Initial state: T-00 Verify that the IUT is able to operate the basic authentication of PT procedure. (IUT has not stored ZAP value and service class information.) Authentication will be based on a User Authentication Key (UAK), so a precondition to this test will be that the UAK is assigned. A DCK will not be stored by the PT. It is assumed that the IUT will reply to the authentication request automatically, without any user intervention needed.</p>
TP/PT/MM/BV/AU-02	<p>DPRS-N.9, Authentication of the PP EN 300 175-5 [2]: 13.3.1, EN 300 444 [5]: 8.24.2.1 Initial state: T-00 Verify that the IUT, on receipt of an {AUTH-REQUEST} message containing unacceptable algorithm, returns an {AUTH-REJECT} message. Authentication will be based on UAK, so a precondition to this test will be that the UAK is assigned.</p>
TP/PT/MM/BV/AU-03	<p>DPRS-N.16, ZAP EN 300 175-5 [2]: 13.3.1, EN 300 444 [5]: 8.26 Initial state: T-00 Verify that the IUT, when it has stored ZAP value, includes the &lt;&lt;ZAP field&gt;&gt; in the {AUTH-REPLY} message during the authentication of PT procedure. Authentication will be based on UAK, so a precondition to this test will be that the UAK is assigned</p>
TP/PT/MM/BV/AU-04	<p>DPRS-N.16, ZAP EN 300 175-5 [2]: 13.3.1, EN 300 444 [5]: 8.26 Initial state: T-00 Verify that the IUT increments the ZAP field during an authentication of PT procedure. The IUT may or may not authenticate the FT before incrementing the ZAP value. Authentication will be based on UAK, so a precondition to this test will be that the UAK is assigned.</p>
TP/PT/MM/BV/AU-05	<p>DPRS-N.16, ZAP EN 300 175-5 [2]: 13.3.1, EN 300 444 [5]: 8.26 Initial state: T-00 Verify that the IUT, if it supports authentication of FT as Part of the increment ZAP procedure, does not increment the ZAP value if the FT authentication fails. Authentication will be based on UAK, so a precondition to this test will be that the UAK is assigned.</p>
TP/PT/MM/BV/AU-07	<p>DPRS-N.10, Authentication of the user EN 300 175-5 [2]: 13.3.2, EN 300 444 [5]: 8.25 Initial state: T-00 Verify that the IUT is able to operate the basic authentication of user procedure.</p>
TP/PT/MM/BV/AU-08	<p>DPRS-N.26, Authentication of FT EN 300 175-5 [2]: 13.3.3, EN 300 444 [5]: 8.23 Initial state: specified in PIXIT Verify that the IUT, after invoking the basic authentication of FT procedure, is able to operate the procedure. Authentication will be based on UAK, so a precondition to this test will be that the UAK is assigned.</p>
TP/PT/MM/BV/AU-09	<p>DPRS-N.16, ZAP EN 300 175-5 [2]: 13.3.1, EN 300 444 [5]: 8.26 Initial state: T-00 Verify that the IUT, when it has stored service class information, includes the &lt;&lt;Service class&gt;&gt; information elements in the {AUTH-REPLY} message during the authentication of PT procedure. Authentication will be based on UAK, so a precondition to this test will be that the UAK is assigned.</p>
TP/PT/MM/TI-02	<p>DPRS-N.9, Authentication of the PP EN 300 175-5 [2]: 13.3.1, EN 300 444 [5]: 8.24.1.1 Initial state: T-00 Verify that the IUT is capable of completing the FT Authentication procedure at a point in time 10 % before expiry of the timer P-&lt;MM_auth.1&gt;.</p>

### 5.3.11 Location registration

DPRS-N.11, Location registration		
	Location registration	EN 300 444 [5]: 8.28
	Location update	EN 300 444 [5]: 8.29
	Terminal capability indication	EN 301 649 [6]: 12.3
DPRS-N.35, Detach		
	Detach	EN 300 824 [7]: 9.5
DPRS-N.36, Periodic location registration		
	Enhanced location registration	EN 300 824 [7]: 9.6
DPRS-N.24, Signalling of display characters		
	Display	EN 300 444 [5]: 8.16
	Terminal capability indication	EN 301 649 [6]: 12.3
DPRS-N.25, Display control characters		
	Display	EN 300 444 [5]: 8.16
	Terminal capability indication	EN 301 649 [6]: 12.3

TP/PT/CC/BV/CI-12	DPRS-N.25, Display control characters EN 300 444 [5]: 8.16 Initial state: T-10 Verify that the IUT, on reception of <<MULTI_DISPLAY>> information elements, containing standard characters in {CC-INFO} messages, is able to show these characters on the display.
TP/PT/CC/BV/CI-13	DPRS-N.24, Signalling of display characters EN 300 444 [5]: 8.16 Initial state: T-10 Verify that the IUT, on reception of <<MULTI_DISPLAY>> information elements, containing control characters in {CC-INFO} messages, is able to understand and react upon these characters.
TP/PT/MM/BV/LO-01	DPRS-N.11, Location registration EN 300 175-5 [2]: 13.4.1, EN 300 444 [5]: 8.28 Initial state: T-00 Verify that the IUT, if the a44 and a38 bits in the broadcast FT "higher layer capabilities" were set to "1", is capable to operate the basic location registration procedure after it performed the obtain access rights procedure. (FT does not perform TPUI assignment).
TP/PT/MM/BV/LO-02	DPRS-N.11, Location registration EN 300 175-5 [2]: 13.4.1, EN 300 444 [5]: 8.28 Initial state: T-00. Verify that the IUT, if the a44 and a38 bits in the broadcast FT "higher layer capabilities" were set to "1", is capable to operate the basic location registration procedure after it performed the obtain access rights procedure. (FT does perform TPUI assignment).
TP/PT/MM/BV/LO-03	DPRS-N.11, Location registration EN 300 175-5 [2]: 13.4.1, EN 300 444 [5]: 8.28 Initial state: T-00. Verify that the IUT, if the a44 bit in the broadcast FT "higher layer capabilities" was set to "1" but a38 is set to "0", does not initiate location registration procedure after it performed the obtain access rights procedure.
TP/PT/MM/BV/LO-04	DPRS-N.11, Location registration EN 300 175-5 [2]: 13.4.1, EN 300 444 [5]: 8.28 Initial state: T-00 Verify that the IUT, if the a38 bit in the broadcast FT "higher layer capabilities" was set to "1" and if location area changes not during a CC-call, is able to operate location registration procedure. (FT does not perform TPUI assignment).
TP/PT/MM/BV/LO-05	DPRS-N.11, Location registration EN 300 175-5 [2]: 13.4.1, EN 300 444 [5]: 8.28 Initial state: T-00. Verify that the IUT, if the a38 bit in the broadcast FT "higher layer capabilities" was set to "1", after power-off and power-on and after locking to the FT to which it has access rights, will initiate location registration procedure.
TP/PT/MM/BV/LO-06	DPRS-N.11, Location registration EN 300 175-5 [2]: 13.4.1, EN 300 444 [5]: 8.28 Initial state: T-00 Verify that the IUT, during a location registration procedure on receipt of a {LOCATE-ACCEPT} message specifying an unacceptable TPUI, will reject the assignment.

TP/PT/MM/BV/LO-07	DPRS-N.11, Location registration EN 300 175-5 [2]: 13.4.1, EN 300 444 [5]: 8.28 Initial state: T-00 Verify that the IUT, entering a new location area, deletes the individual assigned TPUI, before performing the location registration procedure. This shall be done by verifying that the IUT does not return the deleted TPUI in the identity request procedure.
TP/PT/MM/BV/LO-08	DPRS-N.11, Location registration EN 300 175-5 [2]: 13.7, EN 300 444 [5]: 8.29 Initial state: T-00 Verify that the IUT, as Part of the parameter retrieval procedure on receipt of a location update request, will start location registration procedure within reasonable time, when in the broadcast attributes bit a38 was set to "1".
TP/PT/MM/BV/LO-09	DPRS-N.11, Location registration EN 300 175-5 [2]: 13.7, EN 300 444 [5]: 8.29 Initial state: T-00 Verify that the IUT, as Part of the parameter retrieval procedure on receipt of a location update request, will start location registration procedure within reasonable time, even when in the broadcast attributes bit a38 was set to "0".
TP/PT/MM/BV/LO-50	DPRS-N.35, Detach EN 300 824 [7]: 9.5 - 14.4 Initial state: T-00 Verify that the IUT transmits a valid DETACH message to the LT upon power down when the LT is broadcasting a PARI which is not an ARI A.
TP/PT/MM/BV/LO-51	DPRS-N.35, Detach EN 300 824 [7]: 9.5, table 12 - 14.4 Initial state: T-00 The LT simulates 2 base stations(FP_1 and FP_2) with different RFPs. The IUT has subscription to both and is locked to FP_1. Verify that the IUT, when it is locked to the LT(FP_1), transmits a valid DETACH message towards the LT(FP_1) upon changing the active subscription to the subscription with FP_2. The DETACH shall be sent before initiation of location registration to the FP_2.
TP/PT/MM/BV/LO-52	DPRS-N.36, Periodic location registration EN 300 824 [7]: 9.6, table 13 - 14.2 Initial state: T-00 Verify that the IUT periodically repeats the location procedure immediately after the expiry of the time period defined by the <<DURATION>> information element in the LOCATE-ACCEPT message. "Defined time limit 1" is indicated by the LT.
TP/PT/MM/BV/LO-53	DPRS-N.36, Periodic location registration EN 300 824 [7]: 9.6, table 13 - 14.2 Initial state: T-00 Verify that the IUT periodically repeats the location procedure immediately after the expiry of the time period defined by the <<DURATION>> information element in the LOCATE-ACCEPT message. "Defined time limit 2" is indicated by the LT.
TP/PT/MM/BV/LO-54	DPRS-N.36, Periodic location registration EN 300 824 [7]: 9.6, table 13 - 14.2 Initial state: T-00 Verify that the IUT does not repeat the location procedure when the time period defined by the <<DURATION>> information element in the LOCATE-ACCEPT message indicates "Infinite".
TP/PT/MM/BV/LO-55	DPRS-N.36, Periodic location registration EN 300 824 [7]: 9.6, table 13 - 14.2 Initial state: T-00 Verify that the IUT repeats the location procedure immediately after the expiry of the time period defined by the <<DURATION>> information element in the LOCATE-REJECT message. "Defined time limit 1" is indicated by the LT.
TP/PT/MM/BV/LO-56	DPRS-N.36, Periodic location registration EN 300 824 [7]: 9.6 - 14.2 Initial state: T-00 Verify that the IUT will initiate location registration procedure after it locks to the LT(FP) if IUT loses lock and cannot lock again within the time period defined by the <<DURATION>> information element in the LOCATE-ACCEPT message. "Temporary user limit 1" is indicated by the LT.
TP/PT/MM/BV/LO-57	DPRS-N.36, Periodic location registration EN 300 824 [7]: 9.6 - 14.2 Initial state: T-00 Verify that the IUT will initiate location registration procedure after it locks to the LT(FP) if IUT loses lock and cannot lock again within the time period defined by the <<DURATION>> information element in the LOCATE-ACCEPT message. "Temporary user limit 2" is indicated by the LT.

TP/PT/MM/BV/LO-58	DPRS-N.36, Periodic location registration EN 300 824 [7]: 9.6 - 14.2 Initial state: T-00 Verify that the IUT will not initiate location registration procedure after it locks to the LT(FP) if IUT loses lock and cannot lock again within some time when the <<DURATION>> information element in the LOCATE-ACCEPT message indicated. "No limits".
TP/PT/MM/BV/LO-59	DPRS-N.36, Periodic location registration EN 300 175-6 [3]: 6.3.1, EN 300 824 [7]: 9.6, table 13 Initial state: T-00 Verify that the IUT deletes the TPUI if the IUT leaves the locked state with that LT (fails to receive the PARI) for more than T603 seconds when the <<DURATION>> information element in the LOCATE-ACCEPT message received during the last successful location registration indicated "Temporary user limit 2".
TP/PT/MM/BV/LO-60	DPRS-N.36, Periodic location registration EN 300 824 [7]: 9.6, table 14 Initial state: T-00 Verify that when the IUT receives no response to {LOCATE-REQUEST}, it makes a new location registration attempt after at least time N700 and before time N700 + N800.
TP/PT/MM/TI-03	DPRS-N.11, Location registration EN 300 175-5 [2]: 13.2.2, EN 300 444 [5]: 8.28.2.2 Initial state: T-00 Verify that the IUT is capable of completing the Location Registration procedure at a point in time 10 % before expiry of the timer P-<MM_locate.1>.
NOTE:	The phrase "bit a38 was set to 1" means: The bit a38 had the value of 1 during the time the PT locked to the IUT.

### 5.3.12 Access rights

DPRS-N.14, Service class indication/assignment		
	Obtaining access rights	EN 300 444 [5]: 8.30
	Authentication of PT	EN 300 444 [5]: 8.24
DPRS-N.18, Subscription registration user procedure on-air		
	Obtaining access rights	EN 300 444 [5]: 8.30
	Terminal capability indication	EN 301 649 [6]: 12.3
DPRS-N.37, On-air modification of user parameters		
	On-air modification of user parameters	EN 300 824 [7]: 9.8
	FT authentication	EN 300 444 [5]: 8.23
DPRS-N.20, Terminate access rights FT initiated		
	FT terminating access rights	EN 300 444 [5]: 8.31
	Authentication of FT	EN 300 444 [5]: 8.23

TP/PT/MM/BV/AR-01	DPRS-N.14, Service class indication/assignment EN 300 175-5 [2]: 13.5.1, EN 300 444 [5]: 8.30, figure 57 Initial state: No access rights Verify that the IUT, after invocation, if the a44 bit in the broadcast FT "higher layer capabilities" is set to "1" is able to perform the basic operation of the obtain access rights procedure. (PT has only Authentication Code (AC)).
TP/PT/MM/BV/AR-03	DPRS-N.14, Service class indication/assignment EN 300 175-5 [2]: 13.5.1, EN 300 444 [5]: 8.30 Initial state: T-00 Verify that the IUT, after invocation, if the a44 bit in the broadcast FT "higher layer capabilities" is set to "0" does not initiate obtain access rights procedure after it has locked to the FT.

TP/PT/MM/BV/AR-05	DPRS-N.20, Terminate access rights FT initiated EN 300 175-5 [2]: 13.5.2, EN 300 444 [5]: 8.31, figure 58 Initial state: T-00 Verify that the IUT, is able to perform the basic operation of the FT initiated terminate access rights procedure. (IUT may or may not authenticate the FT before performing the procedure).
TP/PT/MM/BV/AR-06	DPRS-N.20, Terminate access rights FT initiated EN 300 175-5 [2]: 13.5.2, EN 300 444 [5]: 8.31.2.1, figure 59 Initial state: T-00 Verify that the IUT, if requested by the FT to terminate the access rights, will first try to authenticate the FT and if this procedure fails, rejects the access rights terminate procedure.
TP/PT/MM/BV/AR-09	DPRS-N.20, Terminate access rights FT initiated EN 300 175-5 [2]: 13.5.1, EN 300 444 [5]: 8.31, figure 58 Initial state: T-00 Verify that the IUT, on receipt of the {ACCESS-RIGHTS-ACCEPT} message containing the information element <<ZAP-FIELD>>, will store this information.
TP/PT/MM/BV/AR-10	DPRS-N.20, Terminate access rights FT initiated EN 300 175-5 [2]: 13.5.1, EN 300 444 [5]: 8.31, figure 58 Initial state: T-00 Verify that the IUT, on receipt of the {ACCESS-RIGHTS-ACCEPT} message containing the information element <<SERVICE-CLASS>>, will store this information.
TP/PT/MM/BV/AR-50	DPRS-N.37, On-air modification of user parameters EN 300 824 [7]: 9.8, table 18 Initial state: T-00 Verify that the IUT correctly performs the procedure of on-air modification of user parameters and that after this procedure the IUT stores the new parameters correctly.
TP/PT/MM/BV/AR-51	DPRS-N.37, On-air modification of user parameters EN 300 824 [7]: 9.8 Initial state: T-00 Verify that the IUT will not initiate the obtain access rights procedure in response to access rights modify suggest if the FT authentication procedure fails.
TP/PT/MM/BV/AR-52	DPRS-N.37, On-air modification of user parameters EN 300 824 [7]: 9.8 Initial state: T-00 Verify that the IUT will not modify the current access rights parameters if the obtain access rights procedure in response to access rights modify suggest fails due to link failure.
TP/PT/MM/BV/AR-53	DPRS-N.37, On-air modification of user parameters EN 300 824 [7]: 9.8 Initial state: T-00 Verify that the IUT will not modify the current access rights parameters if the obtain access rights procedure in response to access rights modify suggest fails due to no answer from the LT(FT).
TP/PT/MM/TI-04	DPRS-N.14, Service class indication/assignment EN 300 175-5 [2]: 13.5.1, EN 300 444 [5]: 8.30.2.2 Initial state: T-00 Verify that the IUT is capable of obtaining Access Rights at a point in time 10 % before expiry of the timer P-<MM_access.1>.

### 5.3.13 On air key allocation

DPRS-N.12, On air key allocation		
	Key allocation	EN 300 444 [5]: 8.32

TP/PT/MM/BV/KA-01	DPRS-N.12, On air key allocation EN 300 175-5 [2]: 13.6, EN 300 444 [5]: 8.32 Initial state: T-00 Verify that the IUT is able to operate the basic key allocation procedure.
TP/PT/MM/BV/KA-02	DPRS-N.12, On air key allocation EN 300 175-5 [2]: 13.6, EN 300 444 [5]: 8.32.2.4, figure 63 Initial state: T-00 Verify that the IUT is able to send an {AUTH_REJECT} message as a response to the key allocation procedure when the <<Allocation type>> information element is not acceptable.
TP/PT/MM/BV/KA-03	DPRS-N.12, On air key allocation EN 300 175-5 [2]: 13.6, EN 300 444 [5]: 8.32.2.5, figure 64 Initial state: T-00 Verify that after failure of the authentication of FT as Part of the key allocation procedure, the PT retains the AC and does not convert it into a User Authentication Key (UAK).
TP/PT/MM/TI-01	DPRS-N.12, On air key allocation EN 300 175-5 [2]: 13.3.3, EN 300 444 [5]: 8.32.2.2 Initial state: T-00 Verify that the IUT, when the timer P-<MM_auth.1> as Part of the key allocation procedure expires after the defined time ( $\pm 5\%$ ), aborts the procedure and thus allows the same priority procedure identity request of PT to proceed.

### 5.3.14 Encryption

DPRS-N.17, Encryption activation FT initiated		
	Cipher-switching initiated by FT	EN 301 649 [6]: 12.12
	Storing the DCK	EN 301 649 [6]: 12.10
DPRS-N.27, Encryption activation PT initiated		
	Cipher-switching initiated by PT	EN 301 649 [6]: 12.13
	Storing the DCK	EN 301 649 [6]: 12.10
DPRS-N.28, Encryption deactivation FT initiated		
	Cipher-switching initiated by FT	EN 301 649 [6]: 12.12
DPRS-N.29, Encryption deactivation PT initiated		
	Cipher-switching initiated by PT	EN 301 649 [6]: 12.13

TP/PT/MM/BV/CH-01	DPRS-N.27, Encryption activation PT initiated EN 300 175-5 [2]: 13.8, EN 300 444 [5]: 8.34 Initial state: specified in PIXIT Verify that the IUT, being in clear mode, is able to operate the basic PT initiated cipher-switching procedure requesting "cipher-on".
TP/PT/MM/BV/CH-02	DPRS-N.29, Encryption deactivation PT initiated EN 300 175-5 [2]: 13.8, EN 300 444 [5]: 8.34 Initial state: specified in PIXIT Verify that the IUT, being in ciphered mode, is able to operate the basic PT initiated cipher-switching procedure requesting "cipher-off".
TP/PT/MM/BV/CH-03	DPRS-N.17, Encryption activation FT initiated EN 300 175-5 [2]: 13.8, EN 300 444 [5]: 8.33 Initial state: T-00 Verify that the IUT, being in clear mode, is able to operate the basic FT initiated cipher-switching procedure requesting "cipher-on".
TP/PT/MM/BV/CH-04	DPRS-N.28, Encryption deactivation FT initiated EN 300 175-5 [2]: 13.8, EN 300 444 [5]: 8.33 Initial state: specified in PIXIT Verify that the IUT, being in ciphered mode, is able to operate the basic FT initiated cipher-switching procedure requesting "cipher-off".
TP/PT/MM/BV/CH-05	DPRS-N.17, Encryption activation FT initiated EN 300 175-5 [2]: 13.8, EN 300 444 [5]: 8.33 Initial state: T-00 Verify that the IUT, being in clear mode, on receipt of a {CIPHER-REQUEST} message containing unacceptable algorithm or key and requesting "cipher-on", will reject the request.



TP/PT/MM/BV/CH-09	DPRS-N.27, Encryption activation PT initiated EN 300 175-7 [4]: 6.4.7, EN 300 444 [5]: 10.15 Initial state: specified in PIXIT Check that the IUT, for a duplex bearer, correctly initiates and completes an intercell bearer handover procedure using basic set-up when encryption is enabled (PT initiated cipher-switching).
TP/PT/MM/BV/CH-10	DPRS-N.27, Encryption activation PT initiated EN 300 175-7 [4]: 6.4.6, EN 300 444 [5]: 10.14 Initial state: specified in PIXIT Check that the IUT, for a duplex bearer, correctly initiates and completes an intracell bearer handover procedure using basic set-up when encryption is enabled (PT initiated cipher-switching).
TP/PT/MM/BV/CH-11	DPRS-N.29, Encryption deactivation PT initiated EN 300 175-7 [4]: 6.4.6, EN 300 444 [5]: 10.14 Initial state: specified in PIXIT Check that the IUT releases the basic Connection when it cannot conclude the procedure to switch from encrypt mode to clear mode (PT initiated cipher off procedure).
TP/PT/MM/BV/CH-12	DPRS-N.17, Encryption activation FT initiated EN 300 175-7 [4]: 6.4.6, EN 300 444 [5]: 10.14 Initial state: T-00 Check that the IUT releases the basic Connection when it cannot conclude the procedure to switch from clear mode to encrypt mode (FT initiated cipher-switching).
TP/PT/MM/BV/CH-13	DPRS-N.17, Encryption activation FT initiated EN 300 175-7 [4]: 6.4.6, EN 300 444 [5]: 10.14 Initial state: T-00 Check that the IUT, for a duplex bearer, correctly initiates and completes an intercell bearer handover procedure using basic set-up when encryption is enabled (FT initiated cipher-switching).
TP/PT/MM/BV/CH-14	DPRS-N.17, Encryption activation FT initiated EN 300 175-7 [4]: 6.4.7, EN 300 444 [5]: 10.15 Initial state: T-00 Check that the IUT, for a duplex bearer, correctly initiates and completes an intracell bearer handover procedure using basic set-up when encryption is enabled (FT initiated cipher-switching).
TP/PT/MM/BV/CH-15	DPRS-N.28, Encryption deactivation FT initiated EN 300 175-7 [4]: 6.4.6, EN 300 444 [5]: 10.14 Initial state: specified in PIXIT Check that the IUT releases the basic Connection when it cannot conclude the procedure to switch from encrypt mode to clear mode (FT initiated cipher off procedure).
TP/PT/MM/BV/CH-data01	DPRS-N.17, Encryption activation FT initiated EN 301 649 [6]: 12.12 Initial state: F-00 Verify that the IUT, that does not support ciphering, rejects a cipher switching request from the PT when a {CIPHER-REQUEST} message has been received, by sending immediately a {CIPHER-REJECT} message.
TP/PT/MM/TI-05	DPRS-N.27, Encryption activation PT initiated EN 300 175-5 [2]: 13.8, EN 300 444 [5]: 8.34.2.2 Initial state: T-00 Verify that the IUT is capable of completing the PT Initiated Ciphering procedure at a point in time 10 % before expiry of the timer P-<MM_cipher.2>.

### 5.3.15 DECT External handover

DPRS-N.33, DECT External handover		
	Handover candidate indication	EN 300 824 [7]: 9.1.1.1
	Handover candidate retrieval	EN 300 824 [7]: 9.1.1.2
	Target FP selection	EN 300 824 [7]: 9.1.2
	Handover reference indication	EN 300 824 [7]: 9.1.3.1
	Handover reference retrieval	EN 300 824 [7]: 9.1.3.2
	External handover call setup	EN 300 824 [7]: 9.1.4
	Ciphering procedure PT initiated	EN 300 824 [7]: 9.1.5.1
	Ciphering procedure FT initiated	EN 300 824 [7]: 9.1.5.2
	U-plane handling	EN 301 649 [6]: 12.21

TP/PT/CC/BV/HP-50	DPRS-N.33, DECT External handover EN 300 824 [7]: 9.1.1.1 Initial state: T-00 Verify that the IUT is able to perform the external handover call setup procedure. The external handover information will have been provided to the IUT in <<Ext h/o indicator>> and <<network parameter>> information elements in a CC-SETUP-ACK message during establishment of the outgoing call.
TP/PT/CC/BV/HP-51	DPRS-N.33, DECT External handover EN 300 824 [7]: 9.1.1.1 Initial state: T-00 Verify that the IUT is able to perform the external handover call setup procedure. The external handover information will have been provided to the IUT in <<Ext h/o indicator>> and <<network parameter>> information elements in a CC-INFO message during establishment of the outgoing call.
TP/PT/CC/BV/HP-52	DPRS-N.33, DECT External handover EN 300 824 [7]: 9.1.1.1 Initial state: T-00 Verify that the IUT is able to perform the external handover call setup procedure. The external handover information will have been provided to the IUT in <<Ext h/o indicator>> and <<network parameter>> information elements in a CC-CONNECT message during establishment of the outgoing call.
TP/PT/CC/BV/HP-53	DPRS-N.33, DECT External handover EN 300 824 [7]: 9.1.1.1 Initial state: T-00 Verify that the IUT is able to perform the external handover call setup procedure. The external handover information will have been provided to the IUT in <<Ext h/o indicator>> and <<network parameter>> information elements in a CC-SETUP message during establishment of the incoming call.
TP/PT/CC/BV/HP-54	DPRS-N.33, DECT External handover EN 300 824 [7]: 9.1.1.1 Initial state: T-00 Verify that the IUT is able to perform the external handover call setup procedure. The external handover information will have been provided to the IUT in <<Ext h/o indicator>> and <<network parameter>> information elements in a CC-INFO message during establishment of the incoming call.
TP/PT/CC/BV/HP-55	DPRS-N.33, DECT External handover EN 300 824 [7]: 9.1.1.2, table 6 Initial state: T-10 Verify that the IUT requests external handover parameters any time during an incoming call if the <<Ext h/o indicator>> information element provided during call setup had the OID value set to "1". Verify that the IUT is subsequently able to successfully complete the external handover call setup procedure.
TP/PT/CC/BV/HP-56	DPRS-N.33, DECT External handover) EN 300 824 [7]: 9.1.3.2 Initial state: T-10 Verify that the IUT applies the handover reference retrieval procedure as soon as possible after establishment of an incoming call (only in CC-active) where the <<network parameter>> information element was not supplied. Verify that the IUT is subsequently able to successfully complete the external handover call setup procedure.
TP/PT/CC/BV/HP-57	DPRS-N.33, DECT External handover EN 300 824 [7]: 9.1.3.2.1 Initial state: T-10 Verify that the IUT starts the handover reference retrieval procedure as soon as possible after establishment of an incoming call (only in CC-active) where the <<network parameter>> information element was not supplied. Verify that the IUT consider the handover reference retrieval procedure as failed upon receipt of a MM_INFO_REJECT and that after such failure the IUT does not attempt to carry out the external handover call setup procedure.
TP/PT/CC/BV/HP-58	DPRS-N.33, DECT External handover EN 300 824 [7]: 9.1.3.2.1 Initial state: T-10 Verify that the IUT starts the handover reference retrieval procedure as soon as possible after establishment of an incoming call (only in CC-active) where the <<network parameter>> information element was not supplied. Verify that the IUT consider the Handover reference retrieval procedure as failed upon expiry of <MM_info.1> and that after such failure the IUT does not attempt to carry out the external handover call setup procedure.

TP/PT/CC/BV/HP-59	DPRS-N.33, DECT External handover EN 300 824 [7]: 9.1.4, table 8 Initial state: T-10 Verify that the IUT is able to perform the external handover call setup procedure and successfully establishes the U-plane on the new connection.
TP/PT/CC/BV/HP-60	DPRS-N.33, DECT External handover EN 300 824 [7]: 9.1.4.2.1 Initial state: T-10 Verify that the IUT is able to complete the external handover call setup procedure successfully when an abnormal link release occurs on the FP-1 link.
TP/PT/CC/BV/HP-61	DPRS-N.33, DECT External handover EN 300 175-5 [2]: 15.7.4.5, EN 300 824 [7]: 9.1.4 Initial state: T-10 Verify that, during the external handover call setup procedure, after call setup is complete on FP-2, the IUT releases the FP-1 link using a {CC-RELEASE} message containing a <<release reason>> indicating "external handover release" if timer N400 expires.
TP/PT/CC/BV/HP-62	DPRS-N.33, DECT External handover EN 300 824 [7]: 9.1.4.2.2 Initial state: T-10 Verify that, after handover has been accepted and the user releases the call, call release procedure as defined in EN 300 444 [5]: 8.7 is used with regard to FP-2.
TP/PT/CC/BV/HP-63	DPRS-N.33, DECT External handover EN 300 824 [7]: 9.1.4.2.2 Initial state: T-10 Verify that, after handover has been accepted and the network releases the call, call release procedure as defined in EN 300 444 [5]: 8.7 is used with regard to FP-2.
TP/PT/CC/BV/HP-64	DPRS-N.33, DECT External handover EN 300 824 [7]: 9.1.4.2.3 Initial state: T-10 Verify that, upon receipt of a link release indication (FP-2) before the handover request to FP-2 has been confirmed, the PT remain connected to FP-1.
TP/PT/CC/BV/HP-65	DPRS-N.33, DECT External handover EN 300 824 [7]: 9.1.5.1 Initial state: T-10 Verify that after performing the external handover call setup procedure on a ciphered connection, the IUT initiates and successfully performs the PT initiated ciphering procedure on the new connection.
TP/PT/CC/BV/HP-66	DPRS-N.33, DECT External handover EN 300 824 [7]: 9.1.5.2 Initial state: T-10 Verify that after performing the external handover call setup procedure, the IUT successfully performs the FT initiated ciphering procedure on the new Connection when the {CIPHER-REQUEST} is sent before the first call is released.
TP/PT/CC/BV/HP-67	DPRS-N.33, DECT External handover EN 300 175-5 [2]: 15.7.6, EN 300 824 [7]: 9.1.5.1 Initial state: T-10 Verify that after performing the external handover call setup procedure, and initiating the PT initiated ciphering procedure on the new connection, the IUT releases the link on FP-2 if PT initiated ciphering fails.
TP/PT/CC/BV/HP-68	DPRS-N.33, DECT External handover EN 300 175-5 [2]: 15.7.6, EN 300 824 [7]: 9.1.5.2 Initial state: T-10 Verify that after performing the external handover call setup procedure, and initiating the FT initiated ciphering procedure on the new connection, the IUT releases the link on FP-2 if FT initiated ciphering fails.
TP/PT/CC/BV/HP-69	DPRS-N.33, DECT External handover EN 300 824 [7]: 14.2 Initial state: T-10 Verify that after performing the external handover call setup procedure to an FP in a different location area, the IUT immediately performs the location registration procedure on the new connection.
TP/PT/CC/BV/HP-70	DPRS-N.33, DECT External handover EN 300 824 [7]: 14.5 Initial state: T-10 Verify that after N501 consecutive unsuccessful external handover attempts, the IUT waits at least N500 seconds before initiating a new external handover attempt.

TP/PT/CC/BV/HP-71	DPRS-N.33, DECT External handover EN 300 824 [7]: 9.1.1.1, table 7 - 9.1.4 Initial state: T-00 Verify the IUT is able to perform the external handover call setup procedure if the <<Ext h/o indicator>> information element provided during call setup indicated multiframe, multiframe number and PSCN synchronization in the SYNC field.
TP/PT/CC/BV/HP-72	DPRS-N.33, DECT External handover EN 300 824 [7]: 9.1.1.1, table 7 - 9.1.4 Initial state: T-00 Verify the IUT is able to perform the external handover call setup procedure if the <<Ext h/o indicator>> information element provided during call setup indicated multiframe and PSCN synchronization in the SYNC field.
TP/PT/CC/BV/HP-73	DPRS-N.33, DECT External handover) EN 300 824 [7]: 9.1.1.1, table 7 - 9.1.4 Initial state: T-00 For those IUTs that support the feature, verify the IUT is able to perform the external handover call setup procedure if the <<Ext h/o indicator>> information element provided during call setup indicated multiframe synchronization in the SYNC field.
TP/PT/CC/BV/HP-74	DPRS-N.33, DECT External handover) EN 300 824 [7]: 9.1.1.1, table 7 - 9.1.4 Initial state: T-00 For those IUTs that support the feature, verify the IUT is able to perform the external handover call setup procedure if the <<Ext h/o indicator>> information element provided during call setup indicated no synchronization in the SYNC field.
TP/PT/CC/BV/HP-75	DPRS-N.33, DECT External handover EN 300 824 [7]: 14.5 Initial state: T-10 Verify that after performing a successful external handover call setup procedure, the IUT will not attempt to perform another external handover call setup until timer N500 has expired.

### 5.3.16 Link control

DPRS-N.19, Link control		
	Indirect FT initiated link establishment	EN 301 649 [6]: 12.15, EN 300 444 [5]: 8.35
	Fast Paging	EN 301 649 [6]: 12.16
	Collective and group ringing	EN 301 649 [6]: 12.17
	Direct FT initiated link establishment	EN 301 649 [6]: 12.18
	Direct PT initiated link establishment	EN 300 444 [5]: 8.36
	Link release "normal"	EN 300 444 [5]: 8.37
	Link release "abnormal"	EN 300 444 [5]: 8.38
	Link release "maintain"	EN 300 444 [5]: 8.39
	Resume Paging	EN 301 649 [6]: 12.19

TP/PT/LC/BV/LE-01	DPRS-N.19, Link control EN 300 175-5 [2]: 14.2.2, EN 300 444 [5]: 8.36 Initial state: T-00 Verify that the IUT, when no link to the FT exists, on receipt of a higher layer message is able to operate a direct link establishment procedure.
TP/PT/LC/BV/LE-02	DPRS-N.19, Link control EN 300 175-5 [2]: 14.2.3, EN 300 444 [5]: 8.35 Initial state: T-00 Verify that the IUT is able to respond to indirect (normal paged) FT-initiated link establishment request which uses a short address request paging and contains correct identity.
TP/PT/LC/BV/LE-data01	DPRS-N.19, Link control EN 300 175-5 [2]: 14.2.1 - 14.2.3, EN 300 444 [5]: 8.35, figure 69 Initial state: T-00 Verify that the IUT is able to respond to indirect (fast paged) FT-initiated link establishment request which uses a short address request paging and contains correct identity.
TP/PT/LC/BV/LE-data02	DPRS-N.19, Link control EN 300 175-5 [2]: 14.2.1 - 14.2.3, EN 300 444 [5]: 8.35, figure 69 Initial state: T-00 Verify that the IUT is able to respond to direct FT-initiated link establishment request which uses a short address request paging and contains correct identity.
TP/PT/LC/BV/LE-data03	DPRS-N.19, Link control EN 301 649 [6]: 12.17 Initial state: T-00 Verify that the IUT is able correctly to handle group ringing and can establish a call when the User responses to the ringing.
TP/PT/LC/BV/LE-data04	DPRS-N.19, Link control EN 301 649 [6]: 12.17 Initial state: T-00 Verify that the IUT is able correctly to handle the collective ringing and can establish a call when the User responses to the ringing.
TP/PT/LC/BV/LR-01	DPRS-N.19, Link control EN 300 175-5 [2]: 14.2.7, EN 300 444 [5]: 8.39 Initial state: T-00 Verify that the IUT is able to perform a normal release after a MM procedure has been accomplished, and no other entities are using the link.
TP/PT/LC/BV/LR-02	DPRS-N.19, Link control EN 300 175-5 [2]: 14.2.7, EN 300 444 [5]: 8.39 Initial state: T-07 Verify that the IUT is able to perform a normal release after a CC-procedure has been accomplished, and no other entities are using the link.
TP/PT/LC/BV/LR-03	DPRS-N.19, Link control EN 300 175-5 [2]: 14.2.7, EN 300 444 [5]: 8.39 Initial state: T-07 Verify that the IUT, after a CC-requested partial release has been agreed, is able to maintain the link for a specified time, and no other entities are using the link.
TP/PT/LC/TI-02	DPRS-N.19, Link control EN 300 175-5 [2]: 14.2.7, EN 300 444 [5]: 8.39 Initial state: T-00 Verify that the IUT, after termination of an MM procedure, maintains the link for a period of <LCE.02>. The link shall be released in the period (<LCE_02> - 1 000) to 10 500 ms.

### 5.3.17 Message Waiting Indication

DPRS-N.34, Message Waiting Indication		
	Message waiting indication	EN 300 824 [7]: 9.7

TP/PT/IS/BV-50	DPRS-N.34, Message Waiting Indication EN 300 824 [7]: 9.7 - 9.7.1, table 16 Initial state: T-00 Verify that the IUT as Part of a Message waiting indication procedure, on reception of a {FACILITY} message containing a <<FACILITY>> information element specifying "numberOfMessages" equal to 127 and 'basicService' equal to "speech (1)" provides a suitable indication to the user that a speech message is waiting.
----------------	---

TP/PT/IS/BV-51	DPRS-N.34, Message Waiting Indication EN 300 824 [7]: 9.7 - 9.7.1, table 16 Initial state: T-00 Verify that the IUT as Part of a Message waiting indication procedure, on reception of a {FACILITY} message containing a <<FACILITY>> information element specifying "numberOfMessages" equal to 127 and 'basicService' equal to "teletex (33)" provides a suitable indication to the user that a teletex message is waiting.
TP/PT/IS/BV-52	DPRS-N.34, Message Waiting Indication EN 300 824 [7]: 9.7 - 9.7.1, table 16 Initial state: T-00 Verify that the IUT as Part of a Message waiting indication procedure, on reception of a {FACILITY} message containing a <<FACILITY>> information element specifying "numberOfMessages" equal to 127 and 'basicService' equal to "allServices (0)" provides a suitable indication to the user that a message is waiting.
TP/PT/IS/BV-53	DPRS-N.34, Message Waiting Indication EN 300 824 [7]: 9.7 - 14.9 Initial state: T-00 Verify that the IUT, starting from a state where there is an indication to the user that a message is waiting, deactivates the indication when the IUT is switched off and on.
TP/PT/IS/BV-54	DPRS-N.34, Message Waiting Indication EN 300 824 [7]: 9.7 - 14.9 Initial state: T-00 Verify that the IUT, starting from a state where there is an indication to the user that a message is waiting, deactivates the indication after receipt of FACILITY messages containing MWIndicate for each basic service specifying a zero numberOfMessages.
TP/PT/IS/BV-55	DPRS-N.34, Message Waiting Indication EN 300 824 [7]: 9.7 - 14.9 Initial state: T-00 Verify that the IUT, after receiving the following sequence of FACILITY messages maintains the message waiting indication for unknown messages: Message 1: MWIndicate{basicService = unknown,numberOfMessages = 1} Message 2: MWIndicate{basicService = speech,numberOfMessages = 1} Message 3: MWIndicate{basicService = speech,numberOfMessages = 0}.
TP/PT/IS/BV-56	DPRS-N.34, Message Waiting Indication EN 300 824 [7]: 14.9 Initial state: T-00 Verify that the IUT will delete the Message waiting information upon changing of subscription (the active IPUI/PARK pair).

### 5.3.18 Distributed communication

DPRS-A.1 Distributed communication		
	HyP (Distributed Communication)	EN 301 649 [6]: annex E

TP/PT/MM/BV/ID-data01	DPRS-A.1 Distributed communication EN 300 175-5 [2]: 14.4 Initial state: T-00 Verify that the IUT on receipt of a {TEMPORARY-IDENTITY-ASSIGN-REQ} message assigning a CL TPUI accepts the assignment.
TP/PT/CL/BV-01	DPRS-A.1 Distributed communication EN 300 175-5 [2]: 12.3.1 Initial state: T-00 Test the IUT's capability of processing a CLMS-FIXED message sent by the FT.
TP/PT/CL/BV-02	DPRS-A.1 Distributed communication EN 300 175-5 [2]: 14.2.1 - 14.2.3 Initial state: T-00 Test the IUT's capability to send a CLMS-VARIABLE.
TP/PT/CL/BV-03	DPRS-A.1 Distributed communication EN 300 175-5 [2]:.2.1 - 14.2.3 Initial state: T-00 Test the IUT's capability to process a CLMS-VARIABLE message.

### 5.3.19 MAC Suspend/Resume

<b>DPRS</b> MAC Suspend/Resume		
	MAC Suspend	EN 301 649 [6]: ??
	MAC Resume	EN 301 649 [6]: ??

TP/PT/CC/BV/SR-data01	<b>EN 301 649 [6]: 10.7.3, 10.7.4</b> Initial state: T-00 Verify that the IUT is able to handle correctly the MAC suspend/resume procedure when the FT initiates the suspend and the FT initiates resume with normal paging.
TP/PT/CC/BV/SR-data02	<b>EN 301 649 [6]: 10.7.3, 10.7.4</b> Initial state: T-00 Verify that the IUT is able to handle correctly the MAC suspend/resume procedure when the FT initiates the suspend and the FT initiates resume with fast paging. IUT need to be put in state that it can handle fast paging.
TP/PT/CC/BV/SR-data03	<b>EN 301 649 [6]: 10.7.3, 10.7.4</b> Initial state: T-00 Verify that the IUT is able to handle correctly the MAC suspend/resume procedure when the FT initiates the suspend and the FT initiates resume with fast setup. IUT need to be put in state that it can handle fast setup.
TP/PT/CC/BV/SR-data04	<b>EN 301 649 [6]: 10.7.3, 10.7.4</b> Initial state: T-00 Verify that the IUT is able to handle correctly at NWK layer the MAC suspend/resume procedure when the PT initiates the suspend and the FT initiates the resume with normal paging.
TP/PT/CC/BV/SR-data05	<b>EN 301 649 [6]: 10.7.3, 10.7.4</b> Initial state: T-00 Verify that the IUT is able to handle correctly at NWK layer the MAC suspend/resume procedure when the PT initiates the suspend and the FT initiates the resume with fast paging. IUT need to be put in state that it can handle fast paging.
TP/PT/CC/BV/SR-data06	<b>EN 301 649 [6]: 10.7.3, 10.7.4</b> Initial state: T-00 Verify that the IUT is able to handle correctly the MAC suspend/resume procedure when the PT initiates the suspend and the FT initiates resume with fast setup. IUT need to be put in state that it can handle fast setup.
TP/PT/CC/BV/SR-data07	<b>EN 301 649 [6]: 10.7.3, 10.7.4</b> Initial state: T-00 Verify that the IUT is able to handle correctly the MAC suspend/resume procedure when the PT initiates the suspend and the PT initiates resume.
TP/PT/CC/BV/SR-data08	<b>EN 301 649 [6]: 10.7.3, 10.7.4</b> Initial state: T-00 Verify that the IUT is able to handle correctly the MAC suspend/resume procedure when the FT initiates the suspend and the PT initiates resume.

---

## Bibliography

The following material, though not specifically referenced in the body of the present document (or not publicly available), gives supporting information.

EN 300 175-1: "Digital Enhanced Cordless Telecommunications (DECT); Common interface; Part 1: Overview".

EN 300 175-2: "Digital Enhanced Cordless Telecommunications (DECT); Common interface; Part 2: Physical layer".

EN 300 175-4: "Digital Enhanced Cordless Telecommunications (DECT); Common interface; Part 4: Data link control layer".

EN 300 175-8: "Digital Enhanced Cordless Telecommunications (DECT); Common interface; Part 8: Speech coding and transmission".

EN 300 435: "Digital Enhanced Cordless Telecommunications (DECT); Data Services Profile (DSP); Base standard including interworking to connectionless networks (service types A and B, class 1)".

EN 300 651: "Digital Enhanced Cordless Telecommunications (DECT); Data Services Profile (DSP); Generic data link service (service type C, class 2)".

ETS 300 699: "Digital Enhanced Cordless Telecommunications (DECT); Data Services Profile (DSP); Generic data link service for closed user groups (service type C, class 1)".

EN 300 701: "Digital Enhanced Cordless Telecommunications (DECT); Data Services Profile (DSP); Generic frame relay service with mobility (service types A and B, class 2)".

ETS 300 755: "Digital Enhanced Cordless Telecommunications (DECT); Data Services Profile (DSP); Multimedia Messaging Service (MMS) with specific provision for facsimile services (service type F, class 2)".

ETS 300 757: "Digital Enhanced Cordless Telecommunications (DECT); Data Services Profile (DSP); Low rate messaging service (service type E, class 2)".

EN 301 240: "Digital Enhanced Cordless Telecommunications (DECT); Data Services Profile (DSP); Point-to-Point Protocol (PPP) interworking for internet access and general multi-protocol datagram transport".



---

## History

<b>Document history</b>			
V0.0.2	November 1999	Public Enquiry	PE 200012: 1999-11-24 to 2000-03-24