



European Standard

**Fixed Radio Systems;
Point-to-point and Multipoint Systems;
Unwanted emissions in the spurious domain and receiver
immunity limits at
equipment/antenna port of Digital Fixed Radio Systems**

Reference

REN/ATTM-04023

Keywords

antenna, DRRS, EMC, emission, immunity

ETSI

650 Route des Lucioles
F-06921 Sophia Antipolis Cedex - FRANCE

Tel.: +33 4 92 94 42 00 Fax: +33 4 93 65 47 16

Siret N° 348 623 562 00017 - NAF 742 C
Association à but non lucratif enregistrée à la
Sous-Préfecture de Grasse (06) N° 7803/88

Important notice

Individual copies of the present document can be downloaded from:

<http://www.etsi.org>

The present document may be made available in more than one electronic version or in print. In any case of existing or perceived difference in contents between such versions, the reference version is the Portable Document Format (PDF). In case of dispute, the reference shall be the printing on ETSI printers of the PDF version kept on a specific network drive within ETSI Secretariat.

Users of the present document should be aware that the document may be subject to revision or change of status. Information on the current status of this and other ETSI documents is available at

<http://portal.etsi.org/tb/status/status.asp>

If you find errors in the present document, please send your comment to one of the following services:

http://portal.etsi.org/chaicor/ETSI_support.asp

Copyright Notification

No part may be reproduced except as authorized by written permission.
The copyright and the foregoing restriction extend to reproduction in all media.

© European Telecommunications Standards Institute 2013.
All rights reserved.

DECT™, PLUGTESTS™, UMTS™ and the ETSI logo are Trade Marks of ETSI registered for the benefit of its Members.
3GPP™ and LTE™ are Trade Marks of ETSI registered for the benefit of its Members and
of the 3GPP Organizational Partners.
GSM® and the GSM logo are Trade Marks registered and owned by the GSM Association.

Contents

Intellectual Property Rights	4
Foreword.....	4
1 Scope	5
2 References	6
2.1 Normative references	6
2.2 Informative references.....	6
3 Definitions, symbols and abbreviations	7
3.1 Definitions.....	7
3.2 Symbols.....	8
3.3 Abbreviations	8
4 Transmitter spurious domain emissions at antenna port	9
4.1 Limits	10
4.1.1 Point-to-point equipment	10
4.1.2 Multipoint equipment with fundamental emission below 21,2 GHz	10
4.1.3 Multipoint equipment with fundamental emission above 21,2 GHz.....	10
4.1.4 Broadband Wireless Access equipment operating between 1 GHz and 6 GHz	11
5 Receiver spurious domain emissions at the antenna port.....	12
6 Spurious domain emissions test method.....	12
7 Receivers immunity at antenna port.....	12
7.1 Limits	12
7.2 Receiver immunity test method.....	13
Annex A (informative): Application of CEPT/ERC Recommendation 74-01.....	14
A.1 Frequency range of applicability	14
A.2 Level limits.....	15
A.3 Reference bandwidths	15
A.4 Detailed application of the reference bandwidths reported in table A.3	18
A.4.1 P-P and P-MP systems with fundamental emissions from 30 MHz to 1 GHz.....	18
A.4.2 P-P and P-MP systems with fundamental emissions from 1 GHz to 21,2 GHz	18
A.4.3 P-P systems with fundamental emissions above 21,2 GHz.....	19
A.4.4 P-MP systems with fundamental emissions above 21,2 GHz	19
Annex B (informative): Measurement background	20
B.1 Spectrum analyser capability.....	20
B.2 Application examples.....	21
History	28

Intellectual Property Rights

IPRs essential or potentially essential to the present document may have been declared to ETSI. The information pertaining to these essential IPRs, if any, is publicly available for **ETSI members and non-members**, and can be found in ETSI SR 000 314: "*Intellectual Property Rights (IPRs); Essential, or potentially Essential, IPRs notified to ETSI in respect of ETSI standards*", which is available from the ETSI Secretariat. Latest updates are available on the ETSI Web server (<http://ipr.etsi.org>).

Pursuant to the ETSI IPR Policy, no investigation, including IPR searches, has been carried out by ETSI. No guarantee can be given as to the existence of other IPRs not referenced in ETSI SR 000 314 (or the updates on the ETSI Web server) which are, or may be, or may become, essential to the present document.

Foreword

This draft European Standard (EN) has been produced by ETSI Technical Committee Access, Terminals, Transmission and Multiplexing (ATTM), and is now submitted for the combined Public Enquiry and Vote phase of the ETSI standards EN Approval Procedure.

Proposed national transposition dates	
Date of latest announcement of this EN (doa):	3 months after ETSI publication
Date of latest publication of new National Standard or endorsement of this EN (dop/e):	6 months after doa
Date of withdrawal of any conflicting National Standard (dow):	18 months after doa

Major changes with respect to previous version

This revision is consequent to recent revision of CEPT/ERC Recommendation 74-01 [4] and inclusion in other ETSI point-to-point standards of systems with bandwidth wider than 500 MHz, which have some different regulation in ECC/REC(02)05 [5] and Recommendation ITU-R SM.1539 [2].

Therefore alignment is needed on the following arguments:

- Spurious emission domain limits for BWA systems in bands between 1 GHz and 6 GHz
- Boundary between out of band and spurious domains for systems with bandwidths > 500 MHz
- Updated of examples in clause B.2

1 Scope

The term Spurious emissions is used for simplicity elsewhere in the present document but with the more broader meaning of "*unwanted emissions in the spurious domain*" introduced by Recommendation ITU-R SM.329 [1] for clarifying the Radio Regulation definitions and the application of recommended limits for all unwanted emissions; it also recommends that spurious emissions limits apply to all unwanted emissions falling in the spurious domain.

Therefore the present document deals with limits for unwanted emissions in the spurious domain at antenna port of Digital Fixed Radio Systems (DFRS) as defined by Recommendation ITU-R SM.329 [1] and CEPT/ERC Recommendation 74-01 [4] and ECC Recommendation (02)05 [5].

Moreover it covers immunity characteristics at receiver's antenna port.

Scope of the present document is to define specific limits at antenna port for spurious emissions domain and receiver immunity for suitable inter-working of Digital Fixed Radio Systems (i.e. Point-to-point and Multipoint systems) in the same or in different frequency band whenever allocated to Fixed Service in the range 9 kHz to 300 GHz.

However systems with fundamental emission below 30 MHz are not considered relevant for Digital Fixed Radio Systems and are outside the scope of the present document.

Spurious emissions domain levels and immunity performance at antenna port are also relevant to essential requirements under article 3.2 of Directive 1999/5/EC [i.12] on Radio equipment and Telecommunication Terminals equipment (R&TTE).

The present document complements CEPT/ERC Recommendation 74-01 [4] which gives limits for Unwanted emissions in the Spurious domain with particular regards to "inter Services" operations, while WG TM4 assumed that in some case more protection is required for compatibility among fixed radio systems deployed in the same geographical area.

Additional considerations and background for producing the present document are:

- Recommendation ITU-R SM.329 [1] considers emissions from any system, including digital modulation and allows options for the definition of the frequency boundary between out-of-band domain and spurious emissions domain. It recommends different category of level limits applicable to the Fixed Service;
- Recommendation ITU-R SM.1539 [2] describes the application of the boundary concept between out-of-band and spurious emission domains;
- Recommendation ITU-R F.1191 [3] define the application of Radio Regulations [i.13] and SM set of Recommendation ITU-Rs concepts of out-of-band, unwanted and spurious emissions to DFRS, clarify the applicability for the boundary between out-of-band and Spurious emissions domains but maintain the same possible limit options provided by ITU-R Recommendation SM.329-10 [1];
- CEPT/ERC Recommendation 74-01 [4], endorses only the more stringent Category B limits of Recommendation ITU-R SM.329-10 [1];
- after the coming into force of RTTE Directive [i.12] the emissions and immunity at antenna port fall under its article 3.2 requirements for "*effective use of spectrum*" and "*avoidance of harmful interference*" and they are no longer an EMC requirement;
- it is convenient to maintain a single EN covering these parameters instead of replicating them on each single product standard, avoiding possible deviation from what required by other CEPT and ITU-R normative;
- limits for unwanted emissions in the spurious domain are supposed to be fixed in view of inter-working compatibility among various Fixed Radio Systems in same or different band exploited in the same area;
- the measurement of the required limits should also be feasible in a suitable and cost effective conformance test (annex B gives also information in this field);
- it is necessary that DFRS receivers provide a minimum level of immunity at antenna port towards possible interference at any frequency band of practical interest;

- a suitable and easy to perform criterion for DFRS receivers' immunity at antenna port may be considered the application of a CW interference.

Some ETSI deliverables for DFRS, sometimes, provide limits for both "external" and "internal" spurious domain emissions and the latter are outside the scope of the present document. Moreover the limits for emissions given in the present document do not prevent more stringent requirement given in those deliverables for intra-system purpose (i.e. local Transmitter to Receiver interference usually referred as "internal").

In order to fix the suitable limits, in annex B, spurious domain emissions are analysed from the point of view of a suitable test method for conformance testing.

2 References

References are either specific (identified by date of publication and/or edition number or version number) or non-specific. For a specific reference, only the cited version applies. For a non-specific reference, the latest version of the referenced document (including any amendments) applies.

Referenced documents which are not found to be publicly available in the expected location might be found at <http://docbox.etsi.org/Reference>.

NOTE: While any hyperlinks included in this clause were valid at the time of publication, ETSI cannot guarantee their long term validity.

2.1 Normative references

The following referenced documents are necessary for the application of the present document.

- [1] Recommendation ITU-R SM.329-12: "Unwanted emissions in the spurious domain".
- [2] Recommendation ITU-R SM.1539-1: "Variation of the boundary between the out-of-band and spurious domains required for the application of Recommendations ITU-R SM.1541 and ITU-R SM.329".
- [3] Recommendation ITU-R F.1191-3: "Necessary and occupied bandwidths and unwanted emissions of digital fixed service systems".
- [4] CEPT/ERC Recommendation 74-01 (2011): " Unwanted emissions in the spurious domain".
- [5] ECC Recommendation (02)05 (2012): "Unwanted emissions".

2.2 Informative references

The following referenced documents are not necessary for the application of the present document but they assist the user with regard to a particular subject area.

- [i.1] ETSI EN 301 126-1: "Fixed Radio Systems; Conformance testing; Part 1: Point-to-Point equipment - Definitions, general requirements and test procedures".
- [i.2] ETSI EN 301 126-2-1: "Fixed Radio Systems; Conformance testing; Part 2-1: Point-to-Multipoint equipment; Definitions and general requirements".
- [i.3] ETSI EN 301 126-2-2: "Fixed Radio Systems; Conformance testing; Part 2-2: Point-to-Multipoint equipment; Test procedures for FDMA systems".
- [i.4] ETSI EN 301 126-2-3: "Fixed Radio Systems; Conformance testing; Part 2-3: Point-to-Multipoint equipment; Test procedures for TDMA systems".
- [i.5] ETSI EN 301 126-2-4: "Fixed Radio Systems; Conformance testing; Part 2-4: Point-to-Multipoint equipment; Test procedures for FH-CDMA systems".

- [i.6] ETSI EN 301 126-2-5: "Fixed Radio Systems; Conformance testing; Part 2-5: Point-to-Multipoint equipment; Test procedures for DS-CDMA systems".
- [i.7] ETSI EN 301 126-2-6: "Fixed Radio Systems; Conformance testing; Part 2-6: Point-to-Multipoint equipment; Test procedures for Multi Carrier Time Division Multiple Access (MC-TDMA) systems".
- [i.8] ETSI EN 302 217-2-2: "Fixed Radio Systems; Characteristics and requirements for point-to-point equipment and antennas; Part 2-2: Digital systems operating in frequency bands where frequency co-ordination is applied; Harmonized EN covering the essential requirements of Article 3.2 of the R&TTE Directive".
- [i.9] ETSI EN 302 217-2-1: "Fixed Radio Systems; Characteristics and requirements for point-to-point equipment and antennas; Part 2-1: System-dependent requirements for digital systems operating in frequency bands where frequency co-ordination is applied".
- [i.10] ETSI TR 101 036-1: "Fixed Radio Systems; Generic wordings for standards on DFRS (Digital Fixed Radio Systems) characteristics; Part 1: General aspects and point-to-point equipment parameters".
- [i.11] Recommendation ITU-R F.746-10: "Radio-frequency arrangements for fixed service systems".
- [i.12] Directive 1999/5/EC of the European Parliament and of the Council of 9 March 1999 on radio equipment and telecommunications terminal equipment and the mutual recognition of their conformity (R&TTE Directive).
- [i.13] ITU-R Radio Regulations (2008) Article 1.

3 Definitions, symbols and abbreviations

3.1 Definitions

For the purposes of the present document, the following terms and definitions apply:

boundary between out-of-band and spurious domains: frequency limit that subdivides the two domains and the applicability

NOTE: Recommendation ITU-Rs SM.329 [1] and SM.1539 [2] describe the possible application to all radio emissions. Recommendation ITU-R F.1191 [3] details it for Fixed Service systems.

EN: European Standard (Telecommunications series)

evaluation bandwidth: bandwidth where the spurious domain emission limits are measured (e.g. the spectrum analyser resolution bandwidth) for further normalization/integration to the reference bandwidth

Broadband wireless access (BWA) system: access system used for the deployment of radio access networks in both the fixed service and the mobile service

Channel Separation(CS): distance between adjacent channels in a radio frequency channels arrangement (defined in ECC or ITU-R or national recommendations)

NOTE 1: it represents one of the major parameters for the identification of the radio equipment use and relevant requirements.

NOTE 2: Some channel arrangements give only a continuous raster of elementary frequency slots for composing multiple ($N \times$ elementary slot) aggregated channels of various size. In this case the actual CS would be equal to the $N \times$ elementary slot used by the radio system. When no channel arrangement or elementary slot raster is defined in the band of operation of the radio system, the occupied bandwidth should be considered in substitution of the CS.

occupied bandwidth: width of a frequency band such that, below the lower and above the upper frequency limits, the mean powers emitted are each equal to a specified percentage $\beta/2$ of the total mean power of a given emission (Radio Regulations [i.13])

NOTE: For the purpose of the present document, $\beta/2$ is assumed to be equal to 0,5 % (Recommendation ITU-R F.1191 [3]).

out-of-band domain (of an emission): frequency range, immediately outside the necessary bandwidth but excluding the *spurious domain*, in which *out-of-band emissions* generally predominate

NOTE: Out-of-band emissions, defined based on their source, occur in the out-of-band domain and, to a lesser extent, in the spurious domain. Spurious emissions likewise may occur in the out-of-band domain as well as in the spurious domain. However, the limit in the out-of-band-domain applies to any unwanted emissions independently from their formal identification as out-of-band or spurious emissions.

out-of-band emissions: any unwanted emission, outside the channel bandwidth, which falls at frequencies separated from the centre frequency of the emission by less than 250 % of the relevant channel separation, where the system is intended to be used.

NOTE: See Recommendation ITU-R F.1191 [3].

receiver spurious emissions: spurious sent backwards to the antenna port by a receiver

NOTE: Sometimes they are also referenced as "spurious radiations"

reference bandwidth: bandwidth where the spurious emission limits are defined

NOTE: See also Recommendation ITU-R SM.329-10 [1].

spurious domain (of an emission): frequency range beyond the *out-of-band domain* in which *spurious emissions* generally predominate

NOTE: Spurious emissions may occur in the out-of-band domain as well as in the spurious domain. Likewise out-of-band emissions, defined based on their source, occur in the out-of-band domain and, to a lesser extent, in the spurious domain. However, the limit in the spurious-domain applies to any unwanted emissions independently from their formal identification as out-of-band or spurious emissions.

spurious emissions: any unwanted emission which falls at frequencies separated from the centre frequency of the emission by 250 % or more of the relevant channel separation, where the system is intended to be used

NOTE: See Recommendation ITU-R F.1191 [3].

unwanted emissions: emissions composed by out-of-band and spurious emissions

3.2 Symbols

For the purposes of the present document, the following symbols apply:

dBc	deciBels relative to carrier mean power
dB _i	deciBel relative to an isotropic radiator
dB _m	deciBels relative to milliwatt
GHz	GigaHertz
kHz	kiloHertz
MHz	MegaHertz

3.3 Abbreviations

For the purposes of the present document, the following abbreviations apply:

ATe	external ATtenuator
ATI	internal spectrum analyser input ATtenuator
ATPC	Automatic Transmission Power Control
BER	Bit Error Rate

BWA Broadband Wireless Access
 BWe evaluation BandWidth for spectral measurement

NOTE: i.e. spectrum analyser resolution bandwidth.

BWr reference BandWidth
 CEPT Conférence Européenne des administrations des Postes et des Télécommunications
 (European Conference of Postal and Telecommunications administrations)
 CS Channel Separation
 CW Continuous Wave
 DFRS Digital Fixed Radio Systems
 DUT Device Under Test
 ECC Electronic Communication Committee of the CEPT
 EMC ElectroMagnetic Compatibility
 ERC European Radiocommunications Committee of the CEPT, presently become ECC
 Fc cut-off Frequency
 HDFFS High Density Fixed Service, according Resolution 75 (WRC 2000)
 IM InterModulation
 i.m.p. intermodulation products
 ITU-R International Telecommunication Union - Radiocommunications standardization sector
 MP MultiPoint

NOTE: Generic term including both P-MP and MP to MP mesh architectures.

MS Master Station of a P-MP system

NOTE: Also known as Base Station in mobile terminology.

P-MP Point-to-MultiPoint system
 P-P Point-to-Point system
 QAM Quadrature Amplitude Modulation
 RF Radio Frequency
 RR Radio Regulations
 RS Repeater Station (of a P-MP system)
 RSL Receiver Signal Level
 R&TTE Radio and Telecommunication Terminals Equipment
 Rx Receiver
 STM-1 Synchronous Transport Module Level 1
 Sub-STM-1 old terminology for STM-0

NOTE: Synchronous Transport Module Level 0.

TS Terminal Station

NOTE: Remote out-station with subscriber interface of a P-MP system.

Tx Transmitter
 VSWR Voltage Standing Wave Ratio
 WRC World Radio Conference

4 Transmitter spurious domain emissions at antenna port

According to Recommendation ITU-R SM.329 [1] and the application to fixed service provided by Recommendation ITU-R F.1191 [3], the spurious domain emissions limits are applied to unwanted emissions at frequencies which are, for channel separations ≤ 500 MHz, ± 250 % of the relevant channel separation outside the nominal carrier frequency (spurious emission domain).

For channel separation > 500 MHz, according Recommendation ITU-R SM.1539 [2] and CEPT/ERC Recommendation 74-01 [4], the spurious domain emissions limits are applied to unwanted emissions at frequencies which are outside the nominal carrier frequency by more than $\pm (500 \text{ MHz} + 150 \%$ of the relevant channel separation expressed in MHz) of the relevant channel separation (spurious emission domain).

According Recommendation ITU-R F.1191 [3], the Channel Separation (CS) is taken as $XS/2$ for alternated frequency channel arrangements and XS for co-channel and interleaved frequency channel arrangements as defined by Recommendation ITU-R F.746 [i.11].

The emission within $\pm 250 \%$, or in case $\pm (500 \text{ MHz} + 150 \%)$, of the relevant channel separation (out-of-band domain) includes only fundamental and unwanted emissions in the out-of-band domain which are outside the scope of the present document.

4.1 Limits

Unless more severe requirement were reported into a specific product ETSI deliverable, the unwanted emissions in the spurious domain delivered at antenna port, of both transmitter and receiver, of Fixed Radio Systems shall be limited within the average power limits reported below.

For "noise-like" emissions, the limits are intended not to be exceeded in any elementary measuring bandwidth.

The limit values are defined at reference point C' shown in the general RF block diagram of figure 1.

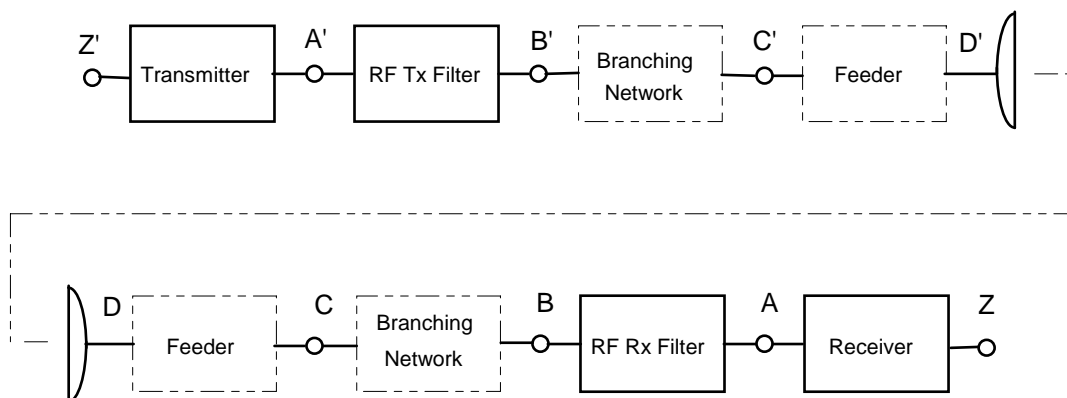

Figure 1: RF block diagram

4.1.1 Point-to-point equipment

The CEPT/ERC Recommendation 74-01 [4] shall apply.

For reader convenience, annex A gives the details for its application to practical systems.

4.1.2 Multipoint equipment with fundamental emission below 21,2 GHz

The CEPT/ERC Recommendation 74-01 [4] shall apply.

For reader convenience, annex A gives the details for its application to practical systems.

4.1.3 Multipoint equipment with fundamental emission above 21,2 GHz

The CEPT/ERC Recommendation 74-01 [4] shall apply as spurious domain emissions limit in the frequency range 9 kHz to 21,2 GHz and above 43,5 GHz.

For spurious domain emissions, falling in the range 21,2 GHz to 43,5 GHz, the tighter limits shown in figures 2 and 3 shall apply to both Central and Terminal Stations.

In this frequency range, where the -40 dBm limit shown in figures 2 and 3 apply, allowance is given for no more than 10 discrete (CW) spurious domain emissions which are permitted to exceed the limit up to -30 dBm.

In the same figures, for comparison, the less stringent limits from CEPT/ERC Recommendation 74-01 [4] are also shown.

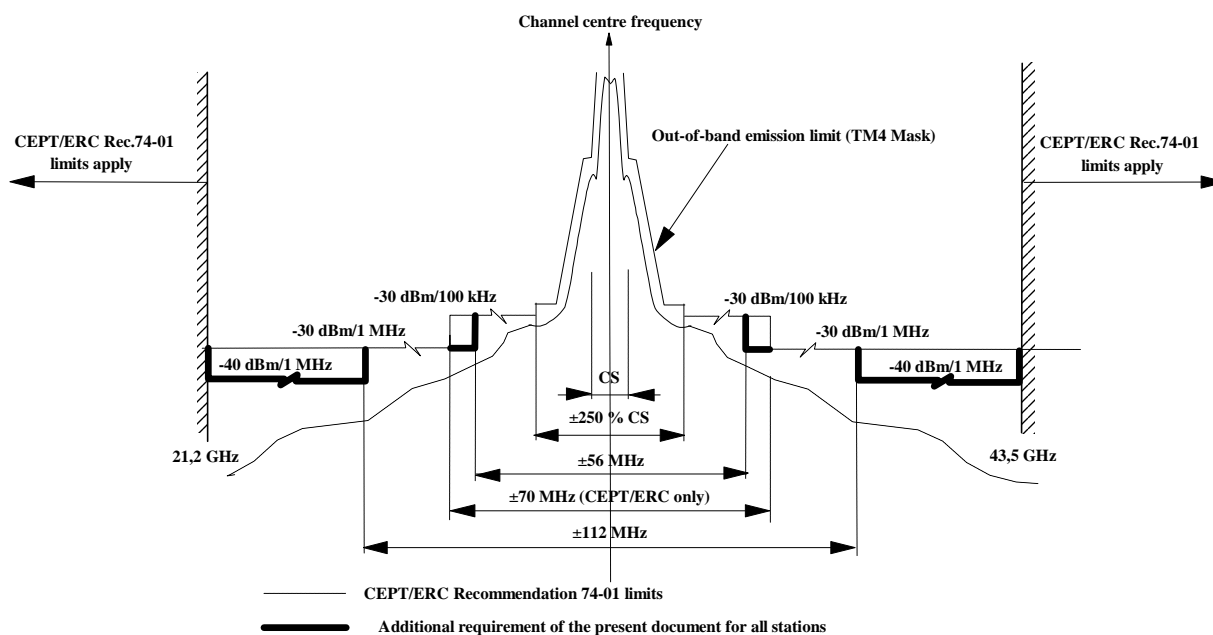

Figure 2: MP equipment for channel separation $1 < CS \leq 10$ MHz

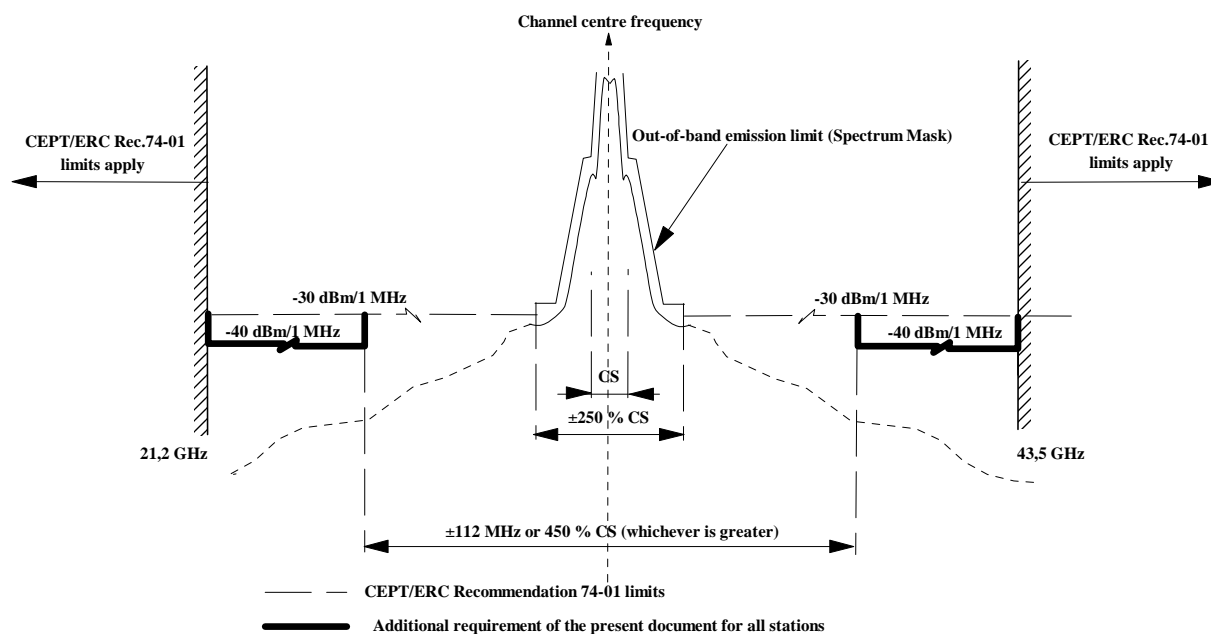

Figure 3: MP equipment for channel separation $CS > 10$ MHz

4.1.4 Broadband Wireless Access equipment operating between 1 GHz and 6 GHz

Broadband Wireless Access (BWA) systems are used for the deployment of radio access networks in both the fixed service and the mobile service. They typically operate at frequencies up to 6 GHz and are considered to use terminal stations with antenna gain less than about 20 dBi.

The CEPT/ERC Recommendation 74-01 [4] shall apply (see note).

For reader convenience, annex A gives the details for its application to practical systems.

NOTE: For coherency CEPT/ERC Recommendation 74-01 [4] considers a unique limit for BWA systems independently from the use of the stations for fixed or mobile traffic (or for both when MS are concerned). Given the predominant mobile use, the land mobile limits are used.

5 Receiver spurious domain emissions at the antenna port

Receiver spurious domain emissions are defined in the same frequency range of transmitters spurious domain emissions, without any exclusion band (such as the 250 % of the relevant channel separation) and are applicable at the reference point C of figure 1.

The CEPT/ERC Recommendation 74-01 [4] shall apply.

6 Spurious domain emissions test method

The measurement shall be referenced at the Tx/Rx common antenna port (reference points C-C' of figure 1).

According to the equipment physical construction, the test shall be carried on with the methodologies given in EN 301 126-1 [i.1] and EN 301 126-2-1 [i.2], EN 301 126-2-2 [i.3], EN 301 126-2-3 [i.4], EN 301 126-2-4 [i.5], EN 301 126-2-5 [i.6] and EN 301 126-2-6 [i.7]. The measurement shall be carried out with transmitters set to the higher level of continuous emission (see note) with the payloads inputs connected to a suitable test pattern, defined, for the equipment under consideration, in the applicable ETSI deliverable, if available, or by manufacturer declaration.

In order to provide easy and cost effective Conformance Test, the measurement may be carried out with wider BWe, provided that the results will be normalized to the required bandwidth with the methods reported in Recommendation ITU-R F.1191-2 [3] and CEPT/ERC Recommendation 74-01 [4].

NOTE: With ATPC disabled and set to the higher emission power.

7 Receivers immunity at antenna port

7.1 Limits

A suitable and easy to perform criterion is considered the application of a CW interference.

CW spurious response rejection ratio of a receiver is a measure of its ability to discriminate between the wanted signal at the nominal channel frequency of the receiver and an unwanted signal at any other frequency at which a response is obtained.

Unless more severe requirement were reported into a specific product ETSI deliverable, for a receiver operating at a RSL corresponding to the nominal 10^{-6} BER threshold given by the relevant ETSI deliverable or in their vacancy by the Manufacturer declaration, the introduction of a CW interfere with respect to the "wanted" signal of:

- a) for Point-to-point equipment operating on channel spacing lower than or equal to 14 MHz:
 - +20 dB at any frequency either side of the wanted centre frequency of the RF channel from 250 % up to 500 % the channel spacing;
 - +30 dB outside 500 % the channel spacing;
- b) for Point-to-point equipment operating on channel spacing greater than 14 MHz:

- +30 dB at any frequency either side of the wanted centre frequency of the RF channel outside 250 % of the channel spacing;
- c) for Multipoint equipment:
- +30 dB at any frequency either side of the wanted centre frequency of the RF channel outside 550 % of the channel spacing;

shall not result in a BER greater than 10^{-5} .

NOTE 1: This requirement is considered equivalent to a degradation of 1 dB of the 10^{-6} BER threshold.

The requirement above shall be fulfilled at any frequency in the range given in table 1 (see note 2).

NOTE 2: In any case, systems having an integral antenna incorporating a waveguide section, or with an antenna connection in such form, and of length equal to at least twice the cut-off wavelength, should not require receiver immunity measurement below 0,7 times the waveguide cut-off frequency.

Table 1

Fundamental receiver frequency range	CW Spurious Response frequency range	
	Lower frequency	Upper frequency (see note)
9 kHz to 100 MHz	9 kHz	1 GHz
100 MHz to 300 MHz	9 kHz	10 th harmonic
300 MHz to 600 MHz	30 MHz	3 GHz
600 MHz to 5,2 GHz	30 MHz	5 th harmonic
5,2 GHz to 13 GHz	30 MHz	26 GHz
13 GHz to 150 GHz	30 MHz	2 nd harmonic
150 GHz to 300 GHz	30 MHz	300 GHz

NOTE: The test should include the entire harmonic band and not be truncated at the precise upper frequency limit stated.

The above kind of immunity does not exclude other more demanding requirement of a specific product ETSI deliverable, if any.

7.2 Receiver immunity test method

The measurement shall be referenced at the Tx/Rx common antenna port (reference points C-C' of figure 1).

According to the equipment physical construction, the test shall be carried on with the methodologies given in EN 301 126-1 [i.1] and EN 301 126-2-1 [i.2], EN 301 126-2-2 [i.3], EN 301 126-2-3 [i.4], EN 301 126-2-4 [i.5] and EN 301 126-2-5 [i.6].

Annex A (informative): Application of CEPT/ERC Recommendation 74-01

The limits of the spurious domain emissions required by the present document are reported in CEPT/ERC Recommendation 74-01 [4]; however, for reader convenience, relevant limits of this recommendation are reported below in relation to those required by the present document.

A.1 Frequency range of applicability

For channel separation ≤ 500 MHz, according to Recommendation ITU-R SM.329 [1] and the application to fixed service provided by Recommendation ITU-R F.1191 [3], CEPT/ERC Recommendation 74-01 [4] defines spurious emissions as any emission at frequencies which are outside the nominal carrier frequency by more than ± 250 % of the relevant channel separation.

For channel separation > 500 MHz, according Recommendation ITU-R SM.1539 [2], CEPT/ERC Recommendation 74-01 [4], defines spurious emissions limits as any unwanted emissions at frequencies which are outside the nominal carrier frequency by more than $\pm (500 \text{ MHz} + 150 \text{ % of the relevant channel separation expressed in MHz})$.

The CEPT/ERC Recommendation 74-01 [4] requires that the limits on spurious domain emissions for radio equipment are considered here to be applicable to the range 9 kHz to 300 GHz. However, for practical measurement purpose only, the frequency range of spurious domain emissions may be restricted. As guidance for practical purposes, the measurement parameters reported in table A.1 are normally recommended by CEPT/ERC Recommendation 74-01 [4].

Table A.1

Fundamental frequency range	Frequency range for measurements	
	Lower frequency	Upper frequency (see note)
9 kHz to 100 MHz	9 kHz	1 GHz
100 MHz to 300 MHz	9 kHz	10 th harmonic
300 MHz to 600 MHz	30 MHz	3 GHz
600 MHz to 5,2 GHz	30 MHz	5 th harmonic
5,2 GHz to 13 GHz	30 MHz	26 GHz
13 GHz to 150 GHz	30 MHz	2 nd harmonic
150 GHz to 300 GHz	30 MHz	300 GHz
NOTE: The test should include the entire harmonic band and not be truncated at the precise upper frequency limit stated.		

These parameters reflect the increasing difficulty in undertaking practicable tests, especially at frequencies approaching or beyond 110 GHz, taking into account such factors as availability and usability of suitable measurement equipment. In such cases, when systems with integral antenna would require radiated measurement, their antenna gain should be taken into account either with separate test or with appropriate theoretical calculation. In some circumstances, it may be necessary to extend the range of test frequencies in order to facilitate better protection of other services, including passive services. In any case, systems having an integral antenna incorporating a waveguide section, or with an antenna connection in such form, and of length equal to at least twice the cut-off wavelength, should not require spurious domain emissions measurement below 0,7 times the waveguide cut-off frequency.

For "noise-like" emissions, the limits are intended not to be exceeded in any elementary reference bandwidth.

A.2 Level limits

The CEPT/ERC Recommendation 74-01 [4] requires the limits reported in table A.2.

Table A.2

SPURIOUS DOMAIN EMISSION LIMITS FOR SYSTEMS IN THE FIXED SERVICE	
Type of equipment	Limits mean power or, when applicable, average power during bursts duration in the applicable reference bandwidth
Fixed Service - Transmitters (all stations except those below)	-50 dBm, for 9 kHz (note 3) $\leq f \leq 21,2$ GHz (note 1) -30 dBm, for 21,2 GHz $< f \leq F_{UPP}$ (see clause A.1) (notes 1 and 3)
Fixed Service - Terminal Stations (remote stations with subscriber equipment interfaces) (note 2)	-40 dBm, for 9 kHz (note 3) $\leq f \leq 21,2$ GHz (note 1) -30 dBm, for 21,2 GHz $< f \leq F_{UPP}$ (see clause A.1) (notes 1 and 3)
BWA systems operating between 1 GHz and 6 GHz (all transmitting stations)	-36 dBm, for 9 kHz $\leq f \leq 1$ GHz (note 1) -30 dBm, for 1 GHz $< f \leq F_{UPPER}$ (clause A.1) (note 1)
Fixed Service - Receivers and idle/standby transmitters, except those below	The same limits as for the transmitters above apply
BWA systems operating between 1 GHz and 6 GHz - Receivers and idle/standby transmitters	- 57 dBm, for 9 kHz $\leq f \leq 1$ GHz - 47 dBm, for 1 GHz $< f \leq F_{UPPER}$ (see clause A.1)
<p>NOTE 1: For digital systems it is necessary to provide one or more steps of reference bandwidth to produce suitable transition area for the spectral density to manage the required limit because in some frequency bands and/or applications narrow-band RF filters are not technically or economically feasible. Consequently, just outside the ± 250 % of the relevant Channel Separation, the limit of spurious domain emissions are defined with reference bandwidths as detailed by the specific figure A.1 and the related table A.3 and for BWA systems the specific figure A.2 and related table A.4.</p> <p>NOTE 2: Point-to-Multipoint systems used in CEPT countries foresee three kinds of stations: - MS Master (Central) Station (clearly identifiable in Recommendation ITU-R SM.329 [1]); - TS Terminal Station (also clearly identifiable in Recommendation ITU-R SM.329 [1]); - RS Repeater Station (which is not referred in Recommendation ITU-R SM.329 [1]). Repeater Stations of Point-to-multipoint systems will be considered as Terminal Stations when they are intended for use only in Remote stations not co-located with any other Fixed radio equipment classified as Central station. When considering Multipoint-to-Multipoint (mesh) access systems, Multipoint-to-Multipoint stations providing co-frequency coverage to a defined area, without addressing any specific Terminal Station (in terms of antenna radiation pattern), should be considered as Master Station.</p> <p>NOTE 3: It is recognized that, for Multipoint systems, with fundamental operating frequency higher than 21,2 GHz, EN 301 390 identifies that the limits, reported in CEPT/ERC Recommendation 74-01 [4], developed at earlier stage, are not enough stringent in the HDFS bands (21,2 GHz to 43,5 GHz) in order to safely deploy the large foreseen number of systems. Therefore, in developing the Harmonized Standards under Directive 1999/5/EC [i.12] (R&TTE Directive) for Multipoint systems, the more stringent limits, reported in EN 301 390 for those bands, have been adopted among essential requirements under article 3.2 of the R&TTE Directive [i.12].</p>	

When burst transmission is used, the mean power of any spurious domain emissions is measured using power averaging over the burst duration.

A.3 Reference bandwidths

The following reference bandwidths are recommended by the CEPT/ERC Recommendation 74-01 [4]:

- 1 kHz for spurious domain emissions falling between 9 kHz and 150 kHz;
- 10 kHz for spurious domain emissions falling between 150 kHz and 30 MHz;
- 100 kHz for spurious domain emissions falling between 30 MHz and 1 GHz;
- 1 MHz for spurious domain emissions falling above 1 GHz.

However, because in some frequency bands and/or applications narrow band RF filters are not technically or economically feasible, it is necessary to provide one or more steps of reference bandwidth to produce suitable transition area for the spectral density to manage the required limit.

Consequently, just outside the $\pm 250\%$ of the relevant channel spacing, the limit of spurious domain emissions are defined within the reference bandwidths detailed in the following figure A.1 and table A.3 in a comprehensive form.

NOTE: The reference bandwidths in figure A.1 and table A.3 are not applicable to receiver spurious domain emissions.

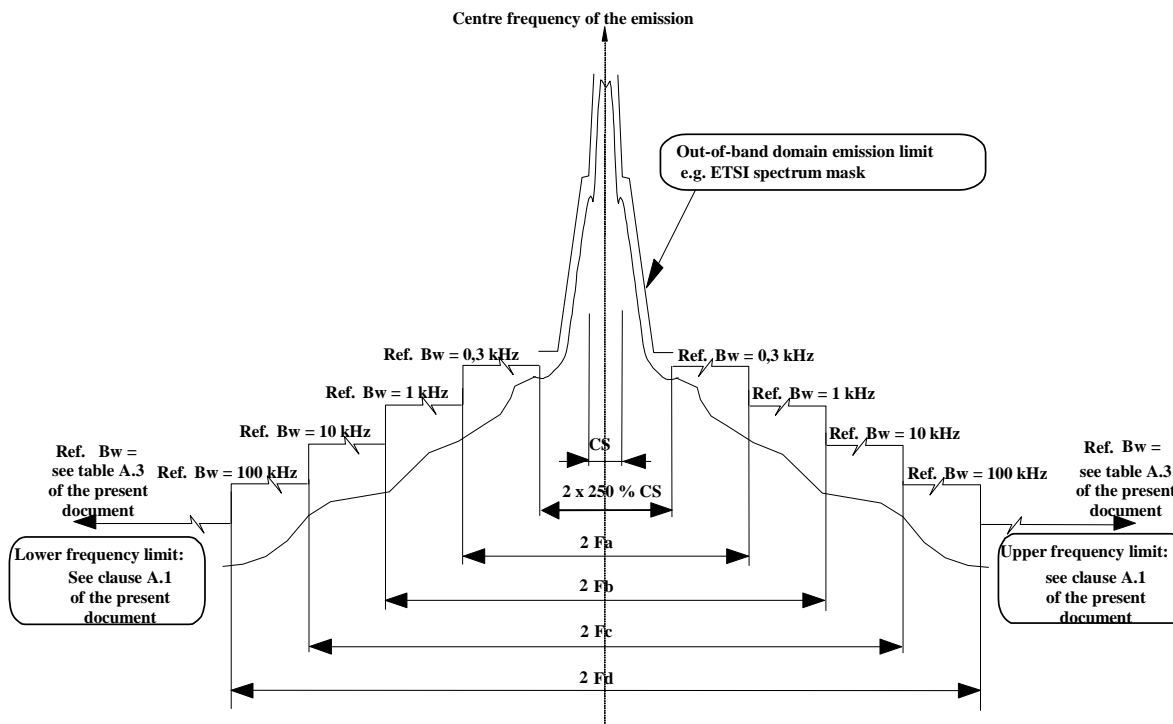

NOTE: $\pm F_d$ frequency steps are not applicable if lower than 1 GHz;
 $\pm F_c$ frequency steps are not applicable if lower than 30 MHz;
 $\pm F_b$ frequency steps are not applicable if lower than 150 kHz.

Figure A.1: Generic spurious domain emission reference bandwidth limits mask (ref. to table A.3)

Table A.3

Fundamental emission	Channel Spacing (CS)	Typical Symbol Rate	BWr 0,3 kHz	BWr 1 kHz	BWr 10 kHz	BWr 100 kHz
Frequency	[MHz]	[-Mbaud/s]	Fa [MHz]	Fb [MHz]	Fc [MHz]	Fd [MHz]
Below 21,2 GHz (Terminal Stations) (Note 4)	$0,01 \leq CS < 1$	$F_s \cong 0,06$ to 0,8	-	-	14	28
	$1 \leq CS < 10$	$F_s \cong 0,6$ to 8	-	-	28	70
	$CS \geq 10$	$F_s \sim > 6$	-	-	49 (note 1)	70 (note 1)
Below 21,2 GHz (Other stations) (Note 4)	$0,01 \leq CS < 1$	$F_s \cong 0,06$ to 0,8	3,5	7	14	28
	$1 \leq CS < 10$	$F_s \cong 0,6$ to 8	-	14 (note 1)	28	70
	$CS \geq 10$	$F_s \sim > 6$	-	-	49 (note 1)	70 (note 1)
Above 21,2 GHz (All stations) (note 2)	$1 \leq CS < 10$	$F_s \cong 0,6$ to 8	-	-	-	70
	$CS \geq 10$	$F_s \sim > 6$	-	-	-	-

NOTE 1: Not applicable where the 250 % of CS exceed these values.
NOTE 2: The CEPT/ERC Recommendation 74-01 [4] does not make distinction for stations operating above 21,2 GHz, however for the purpose of the present document, the more stringent limits of clause 4.1.3 apply to P-MP systems only.
NOTE 3: It is recognized that, depending on the characteristic of the emissions, the actual power density relative to the ETSI mask at the $\pm 250\%$ boundary, when evaluated in the reference bandwidth of one or more steps of table A.3, may be lower than the spurious domain emission limit itself. In such cases these steps are not applicable and the first applicable spurious domain emission reference bandwidth step, which corresponds to a power density equal or lower than that evaluated with the ETSI mask in the same reference bandwidth, should be extended back to the $\pm 250\%$ boundary (examples of this concept are shown in clause B.2 (figures B.4, B.7, B.9 and B.11)).
NOTE 4: Excluding BWA systems operating between 1 GHz and 6 GHz for which limits of figure A.2 and table A.4 apply.

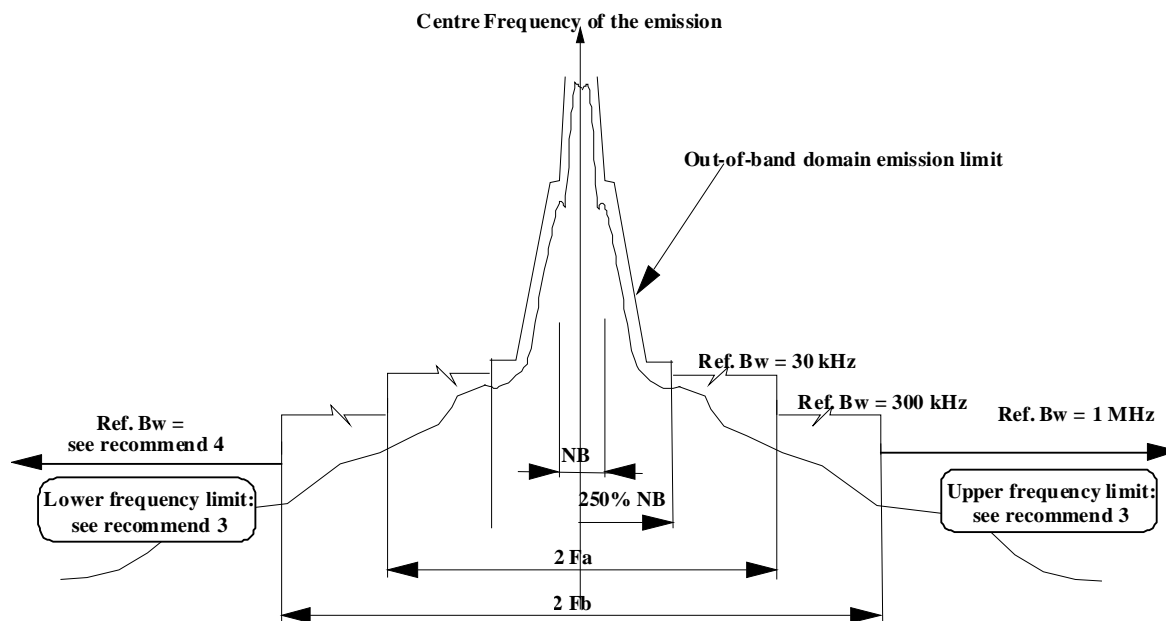

Figure A.2: Generic spurious domain emission reference bandwidth limits mask (ref. to table A.4) for BWA systems operating between 1 GHz and 6 GHz.

Table A.4

Fa*	500 kHz or 10 times NB, whichever is the greater
Fb*	1 MHz or 12 times NB, whichever is the greater
* Frequency references for Figure A.2	

A.4 Detailed application of the reference bandwidths reported in table A.3

The above generic figures are detailed for the different ranges of transmitter fundamental emissions as follows.

A.4.1 P-P and P-MP systems with fundamental emissions from 30 MHz to 1 GHz

a) BW_r is taken equal to 0,3 kHz for:

- $0,01 \leq CS < 1$ MHz in the range from ± 250 % of CS to $\pm 3,5$ MHz.

NOTE 1: Not applicable to TS and RS remote out-stations for which the -40 dBm limit apply.

b) BW_r is taken equal to 1 kHz for:

- $0,01 \leq CS < 1$ MHz in the range from $\pm 3,5$ MHz to ± 7 MHz; and for
- $1 \text{ MHz} \leq CS < 5,6$ MHz in the range from ± 250 % of channel spacing to ± 14 MHz.

NOTE 2: Not applicable to TS and RS remote out-stations for which the -40 dBm limit apply.

c) BW_r is taken equal to 10 kHz for:

- Terminal Stations, for which the -40 dBm limit apply, for:
 - $0,01 \leq CS < 1$ MHz in the range from ± 250 % of CS to ± 14 MHz; for
 - $1 \text{ MHz} \leq CS < 10$ MHz in the range from ± 250 % of CS to ± 28 MHz; and for
 - $10 \text{ MHz} \leq CS < 19,6$ MHz in the range from ± 250 % of CS to ± 49 MHz.
- other stations for:
 - $0,01 \leq CS < 1$ MHz in the range from 7 MHz to ± 14 MHz; for
 - $1 \text{ MHz} \leq CS < 5,6$ MHz in the range from ± 14 MHz to ± 28 MHz; for
 - $5,6 \text{ MHz} \leq CS < 10$ MHz in the range from ± 250 % of CS to ± 28 MHz; and for
 - $10 \text{ MHz} \leq CS < 19,6$ MHz in the range from ± 250 % of CS to ± 49 MHz.

A.4.2 P-P and P-MP systems with fundamental emissions from 1 GHz to 21,2 GHz

a) BW_r is taken equal to 0,3 kHz for:

- $0,01 \leq CS < 1$ MHz in the range from ± 250 % of CS to $\pm 3,5$ MHz.

NOTE 1: Not applicable to TS and RS remote out-stations for which the -40 dBm limit apply.

b) BW_r is taken equal to 1 kHz for:

- $0,01 \leq CS < 1$ MHz in the range from $\pm 3,5$ MHz to ± 7 MHz; and for
- $1 \text{ MHz} \leq CS < 5,6$ MHz in the range from ± 250 % of channel spacing to ± 14 MHz.

NOTE 2: Not applicable to TS and RS remote out-stations for which the -40 dBm limit apply.

- c) BWr is taken equal to 10 kHz for:
- Terminal Stations for which the -40 dBm limit apply for:
 - $0,01 \leq CS < 1$ MHz in the range from ± 250 % of CS to ± 14 MHz; for
 - $1 \text{ MHz} \leq CS < 10$ MHz in the range from ± 250 % of CS to ± 28 MHz; and for
 - $10 \text{ MHz} \leq CS < 19,6$ MHz in the range from ± 250 % of CS to ± 49 MHz.
 - other stations for:
 - $0,01 \leq CS < 1$ MHz in the range from 7 MHz to ± 14 MHz; for
 - $1 \text{ MHz} \leq CS < 5,6$ MHz in the range from ± 14 MHz to ± 28 MHz; for
 - $5,6 \text{ MHz} \leq CS < 10$ MHz in the range from ± 250 % of CS to ± 28 MHz; and for
 - $10 \text{ MHz} \leq CS < 19,6$ MHz in the range from ± 250 % of CS to ± 49 MHz.
- d) BWr is taken equal to 100 kHz for:
- $0,01 \leq CS < 1$ MHz in the range from ± 14 MHz to ± 28 MHz; for
 - $1 \text{ MHz} \leq CS < 10$ MHz in the range from ± 28 MHz to ± 70 MHz; for
 - $10 \text{ MHz} \leq CS < 19,6$ MHz in the range from ± 49 MHz to ± 70 MHz; and for
 - $19,6 \text{ MHz} \leq CS < 28$ MHz in the range from ± 250 % of CS to ± 70 MHz.

A.4.3 P-P systems with fundamental emissions above 21,2 GHz

BWr is taken equal to 100 kHz for:

- $1 \text{ MHz} \leq CS < 10$ MHz in the range from ± 250 % of CS to ± 70 MHz.

A.4.4 P-MP systems with fundamental emissions above 21,2 GHz

For these systems the CEPT/ERC Recommendation is less stringent than the present document, see clause 4.1.3.

Annex B (informative): Measurement background

B.1 Spectrum analyser capability

The generic set-up for emissions measurement is shown in figure B.1.

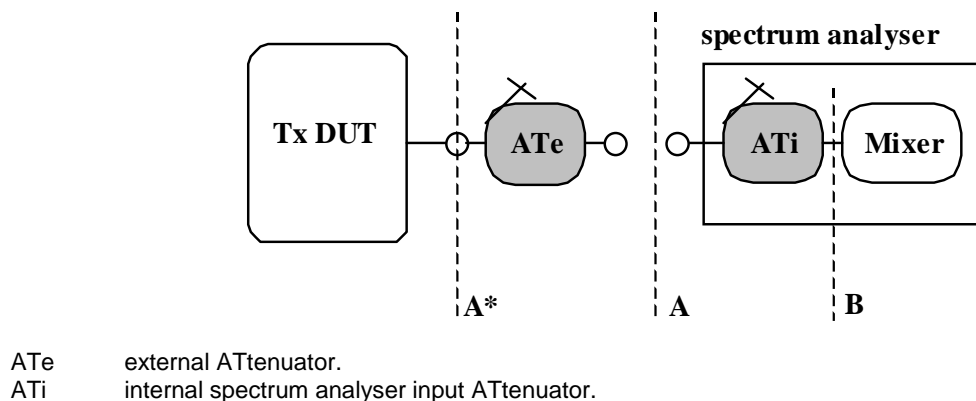

Figure B.1: Spectrum measurement test schematic

When digital modulation is concerned the available limits of measurement from a spectrum analyser are to be taken into account (see TR 101 036-1 [i.10]).

The following limitation for the spectrum analyser measurement applies depending on the characteristic of the instrument used:

- 1) B_{3rd} : Safe average input level at point B for distortion (at mixer input) (e.g. third order intermodulation reduction > 50 dBc);
- 2) B_{Max} : Max. input level at point B (e.g. with 10 dB attenuation for VSWR opt.);
- 3) minimum displayed absolute level of the equivalent noise floor at A* point:
 - with > 50 dBc i.m.p. = Min displ. noise at A + (ATi + ATe);
= Min displ. noise at A + (Pout - B_{3rd}).
 - absolute minimum (with 10 dB Att. for VSWR):
= Min displ noise at A + (Pout - B_{Max});
or (whichever is greater);
= Min displ. noise at A + 10 dB.
- 4) At high frequency (e.g. higher than about 60 GHz) direct test might not be available (note) and external frequency converters may be needed. Their sensitivity has been estimated from available data at the time of publication of the present document.

NOTE: The analyser technology at these bands might rapidly evolve as consequence of increasing market demand for millimetric band equipment.

B.2 Application examples

The following figures show applications of the limits provided by the present document and other limits for some spectrum masks provided in EN 302 217-2-2 [i.8] or EN 302 217-2-1 [i.9].

The spectrum masks are defined to limit the out-of-band portion of the emission (i.e. within the $\pm 250\%$ of the relevant CS or $\pm(150\% + 500\text{ MHz})$ when applicable) together with the recommended reference bandwidth for conformance test purpose; however to visualize how the out-of-band portion of the spectral density fits to the spurious domain emissions limit at their boundary, the relative spectrum mask and the actual output power may be used to normalize the mask into a power density within the reference bandwidth where the first step of spurious domain emissions limit is defined.

NOTE: For discrete components of spurious domain emissions this normalization is not effective provided that their limit is independent from the reference bandwidth.

The output power of the systems (necessary to evaluate the absolute level of the signal spectral density and to set the values of the attenuators AT_i and AT_e) has been taken as a typical achievable level in the relevant frequency band.

In the following figures two noise floor limits of spectrum analyser are shown and marked with explanatory notes.

The noise floor limit with $> 50\text{ dB}$ i.m.p. has been shown for example only, however in practice it may be necessary for near carrier measurement of QAM systems only, not to impair the precision. Others have to be evaluated case by case (see TR 101 036-1 [i.10] for background in this field).

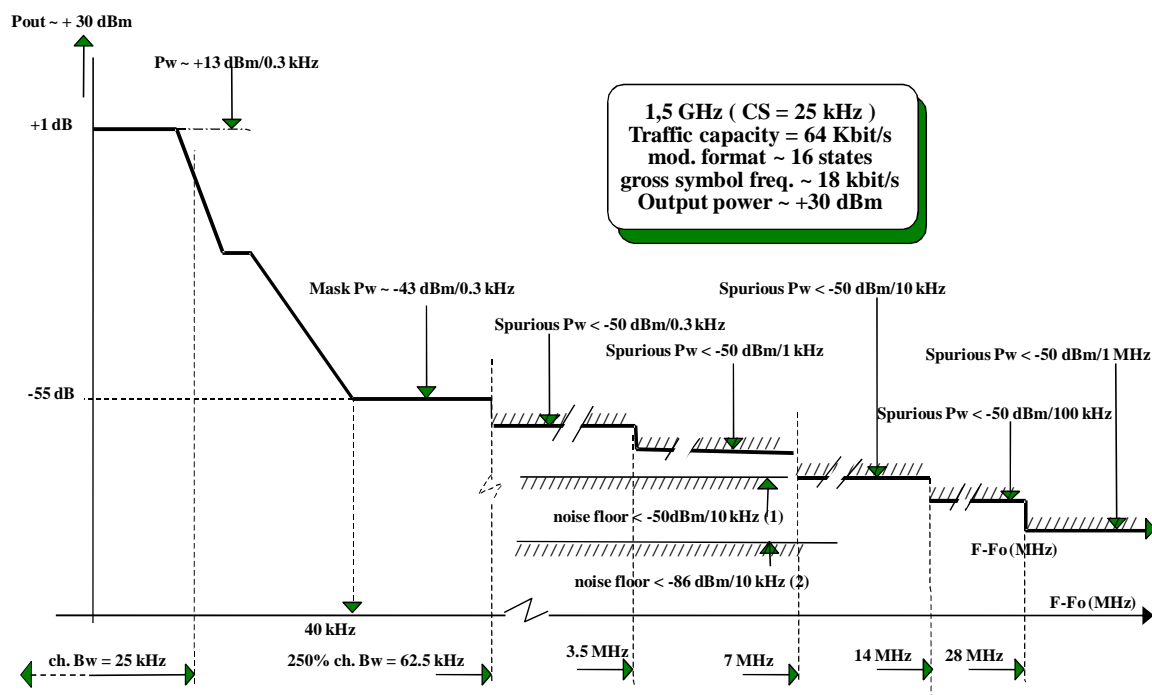

NOTE 1: Typical noise floor with 3rd order i.m.p. $> 50\text{ dB}$.

NOTE 2: Typical noise floor with maximum input level (highest dynamic range).

Figure B.2

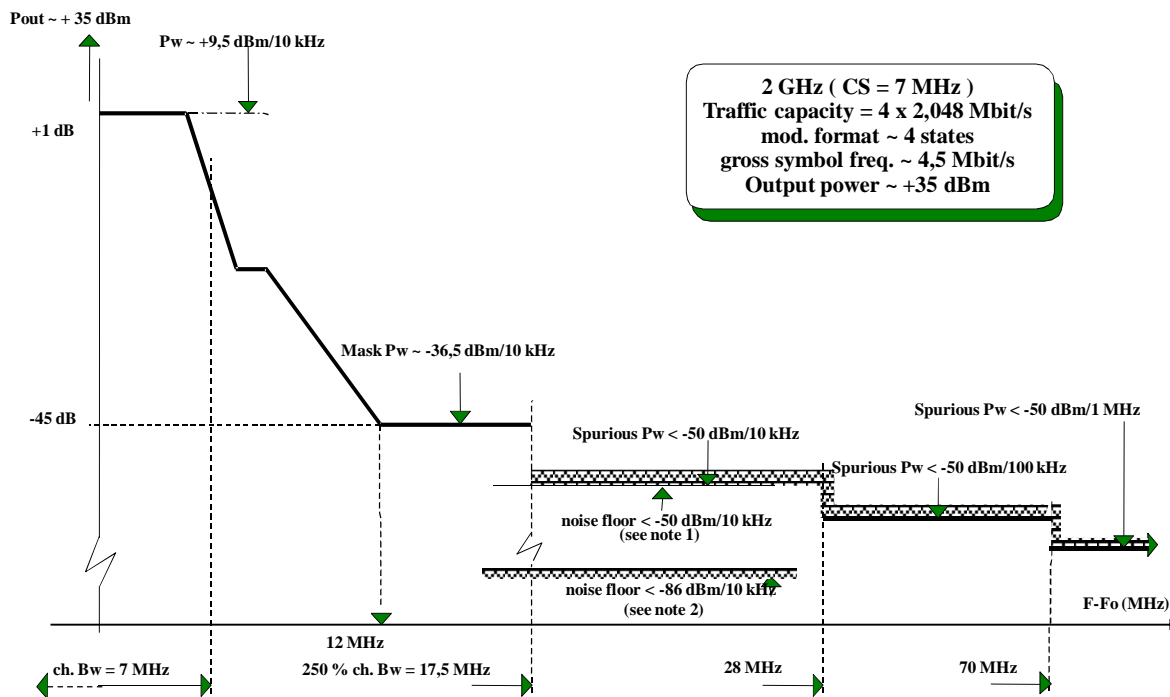

NOTE 1: Typical noise floor with 3rd order i.m.p. > 50 dB.
 NOTE 2: Typical noise floor with maximum input level (highest dynamic range).

Figure B.3

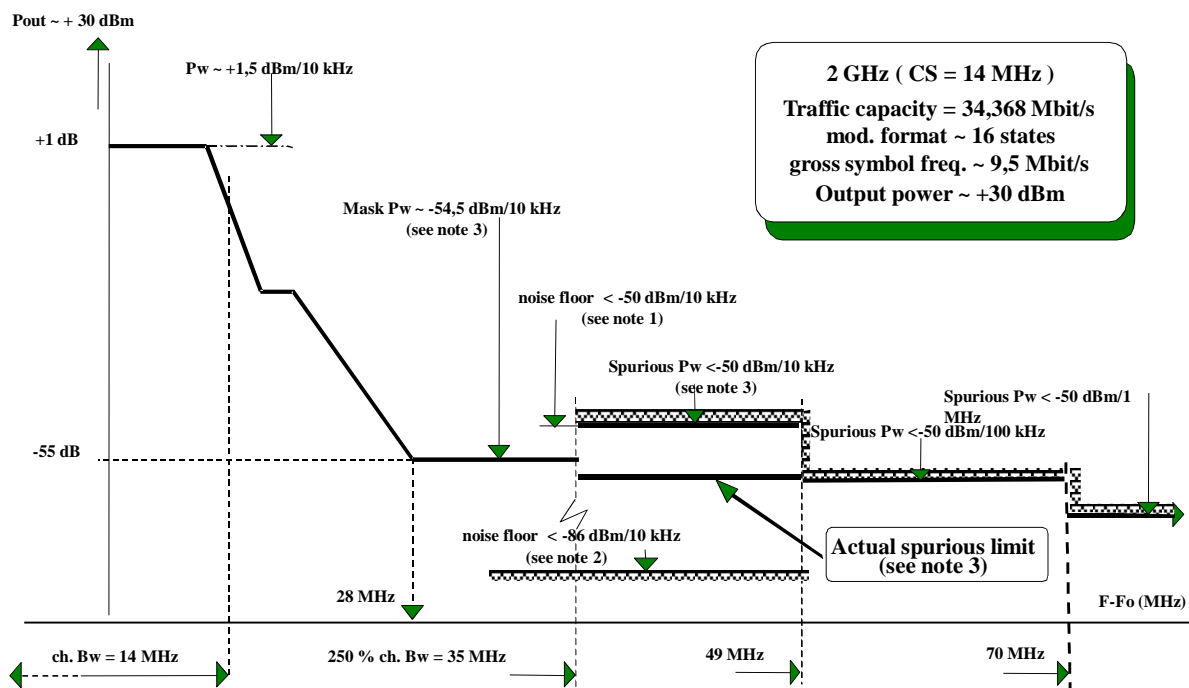

NOTE 1: Typical noise floor with 3rd order i.m.p. > 50 dB.
 NOTE 2: Typical noise floor with maximum input level (highest dynamic range).
 NOTE 3: Example of reference bandwidth step not applicable (see note 3 in table A.3).

Figure B.4

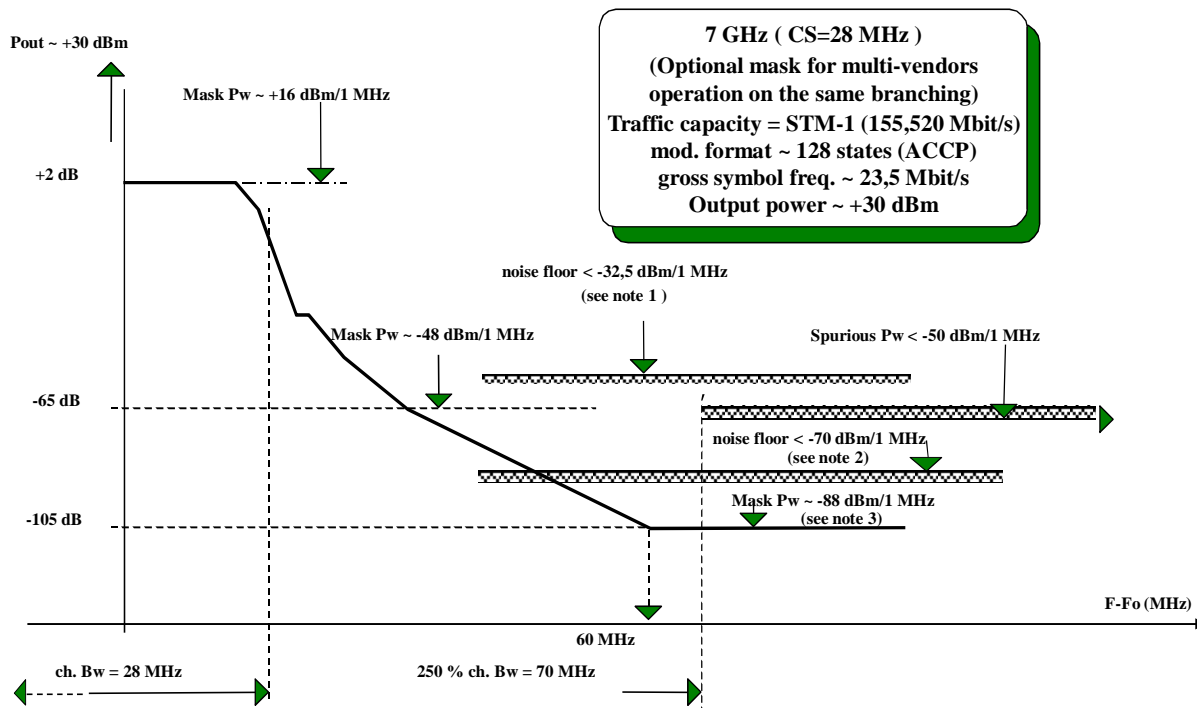

NOTE 1: Typical noise floor with 3rd order i.m.p. > 50 dB.
 NOTE 2: Typical noise floor with maximum input level (highest dynamic range).
 NOTE 3: Intra system compatibility only (see EN 302 217-2-1 [i.9]).

Figure B.5

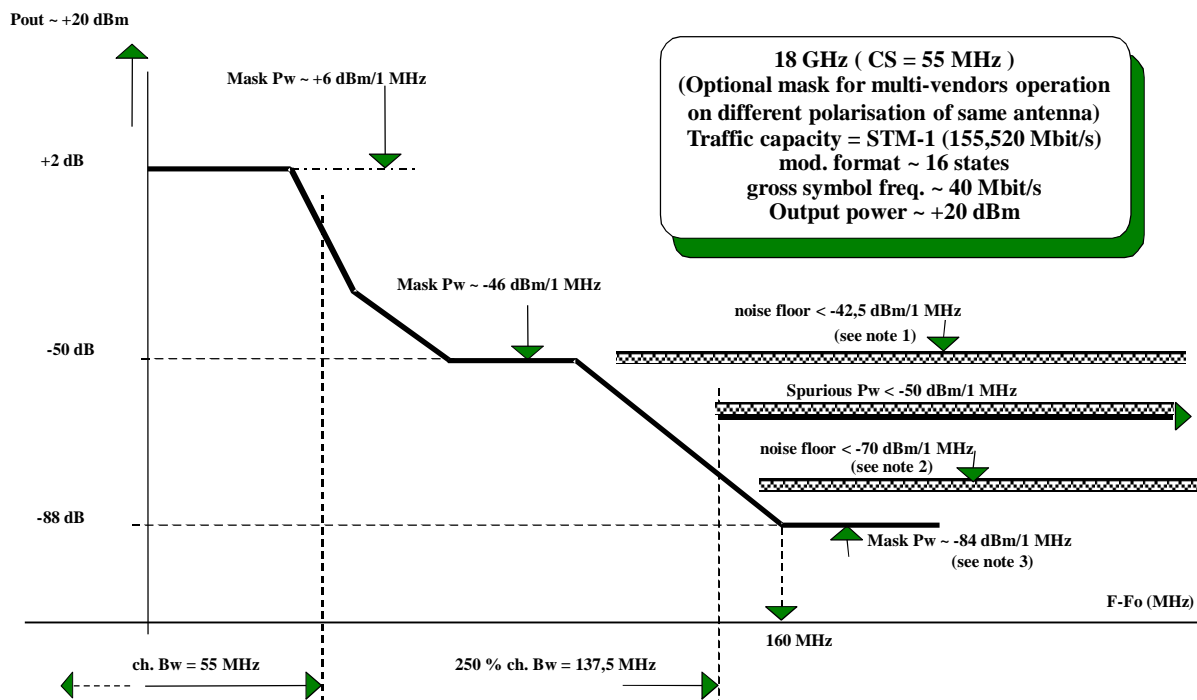

NOTE 1: Typical noise floor with 3rd order i.m.p. > 50 dB.
 NOTE 2: Typical noise floor with maximum input level (highest dynamic range).
 NOTE 3: Intra system compatibility only (see EN 302 217-2-1 [i.9]).

Figure B.6

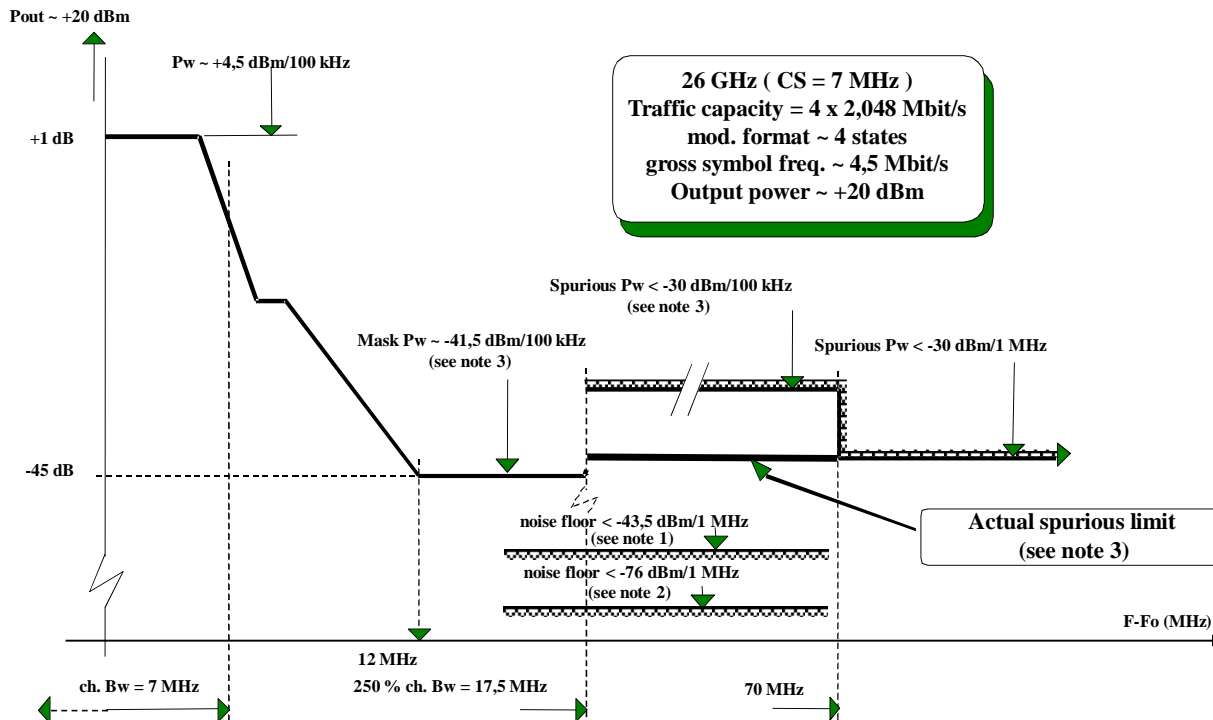

NOTE 1: Typical noise floor with 3rd order i.m.p. > 50 dB.
 NOTE 2: Typical noise floor with maximum input level (highest dynamic range).
 NOTE 3: Example of reference bandwidth step not applicable (see note 3 in table A.3).

Figure B.7

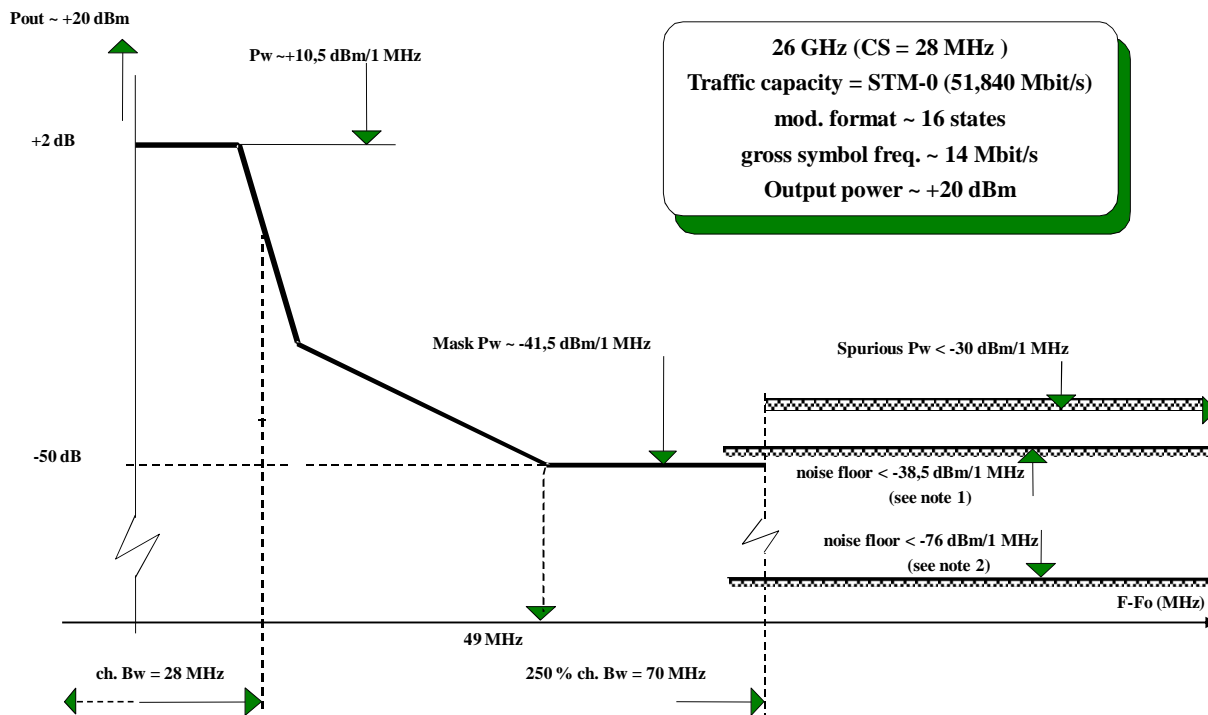

NOTE 1: Typical noise floor with 3rd order i.m.p. > 50 dB.
 NOTE 2: Typical noise floor with maximum input level (highest dynamic range).

Figure B.8

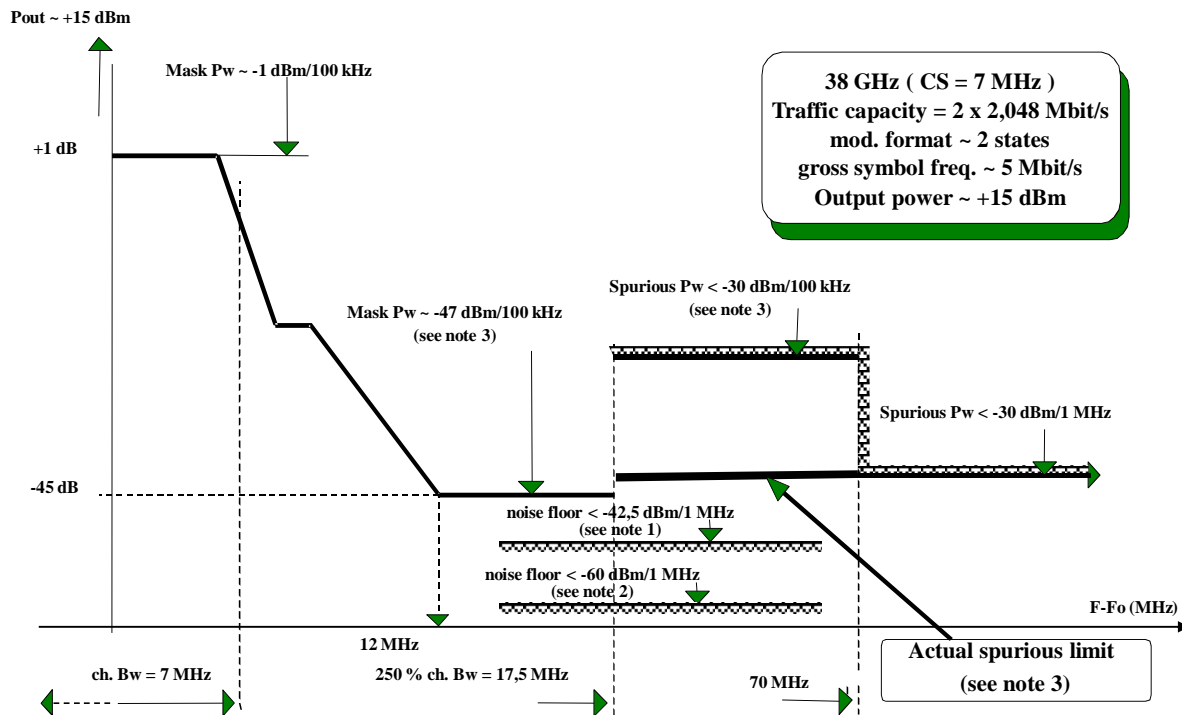

NOTE 1: Typical noise floor with 3rd order i.m.p. > 50 dB.
 NOTE 2: Typical noise floor with maximum input level (highest dynamic range).
 NOTE 3: Example of reference bandwidth step not applicable (see note 3 in table A.3).

Figure B.9

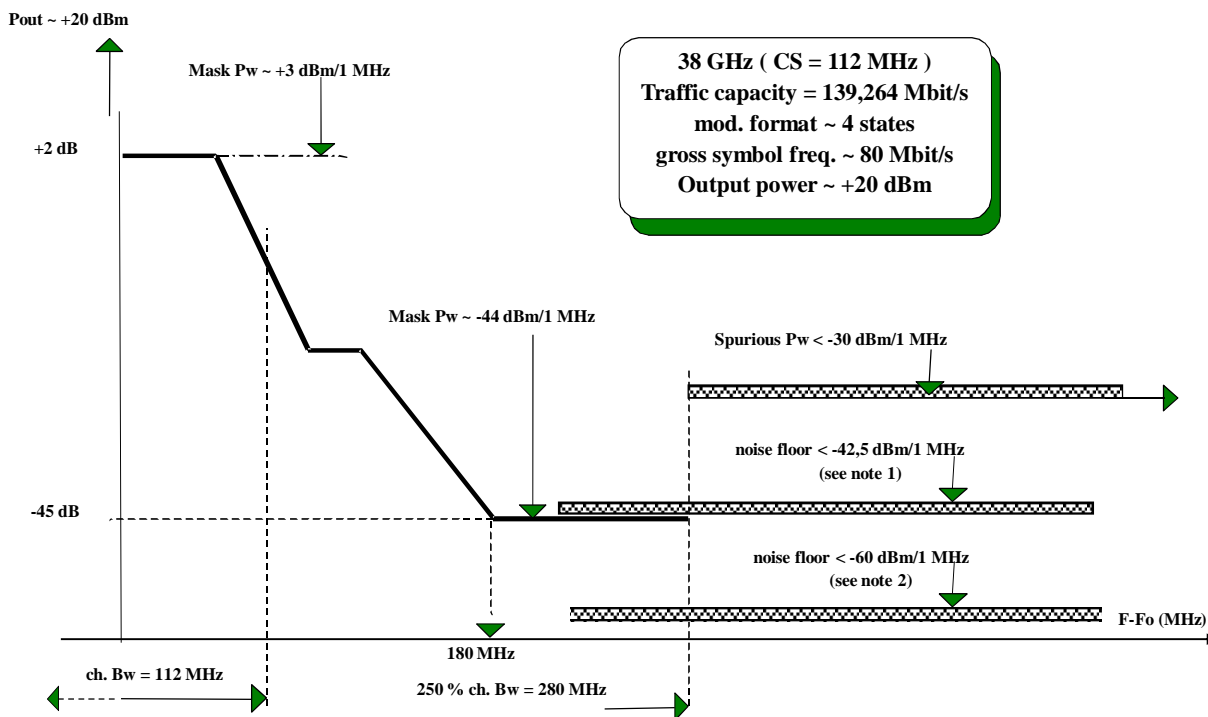

NOTE 1: Typical noise floor with 3rd order i.m.p. > 50 dB.
 NOTE 2: Typical noise floor with maximum input level (highest dynamic range).

Figure B.10

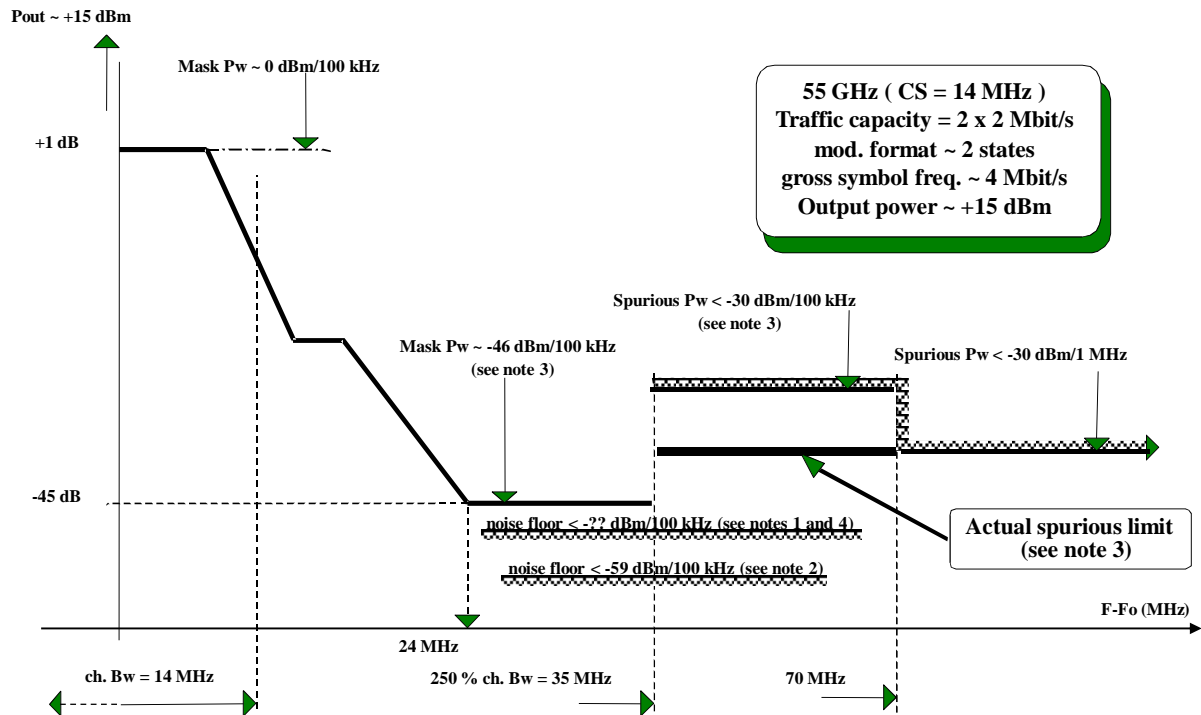

NOTE 1: Typical noise floor with 3rd order i.m.p. > 50 dB.

NOTE 2: Typical noise floor with maximum input level (highest dynamic range).

NOTE 3: Example of reference bandwidth step not applicable (see note 3 in table A.3).

NOTE 4: The displayed noise level depends on the 3rd IM capability of the external mixer (if used).

Figure B.11

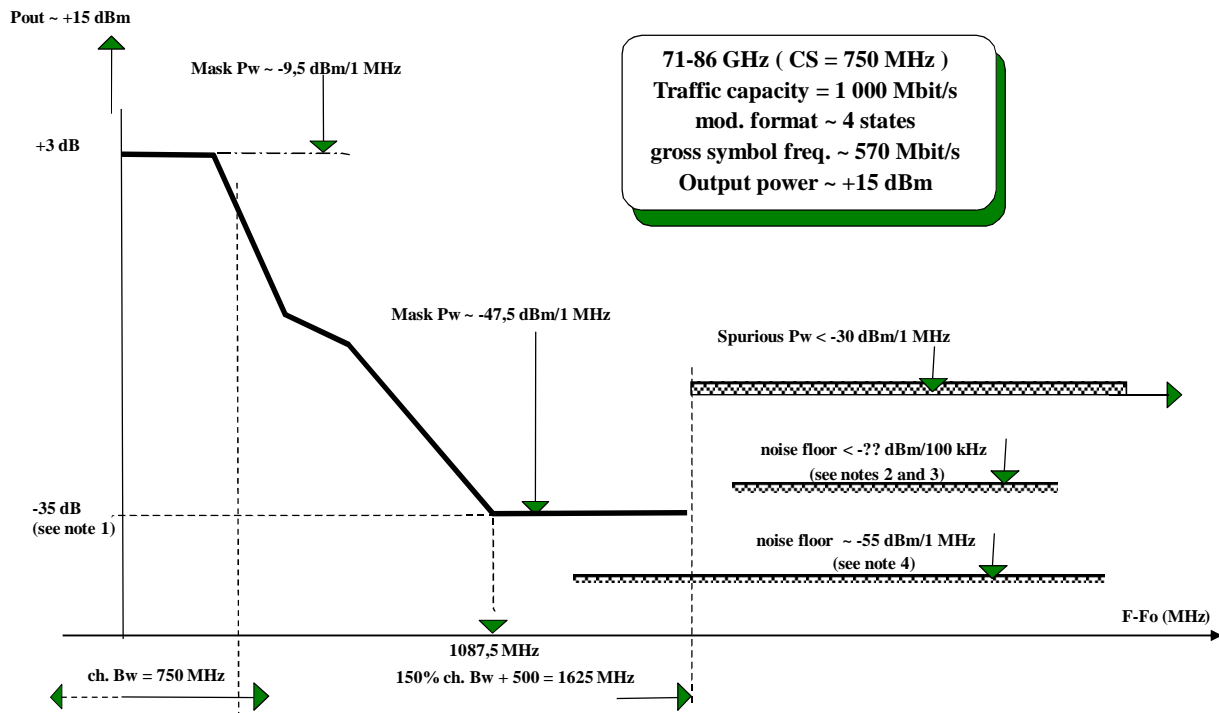

NOTE 1: Mask floor attenuation $\{40 - 10 \log(750/250)\}$ dB (see EN 302 217-2-2 [i.8])

NOTE 2: Typical noise floor with 3rd order i.m.p. > 50 dB.

NOTE 3: The displayed noise level depends on the 3rd IM capability of the external mixer.

NOTE 4: Typical noise floor with maximum input level (highest dynamic range estimated as ~70 dB).

Figure B.12

History

Document history		
V1.1.1	December 2000	Publication
V1.2.1	November 2003	Publication
V1.3.0	April 2013	EN Approval Procedure AP 20130809: 2013-04-11 to 2013-08-09