

Final draft **ETSI EN 301 390** V1.2.1 (2003-07)

European Standard (Telecommunications series)

**Fixed Radio Systems;
Point-to-point and Multipoint Systems;
Spurious emissions and receiver immunity limits at
equipment/antenna port of Digital Fixed Radio Systems**



Reference

REN/TM-04156

Keywords

antenna, DRRS, EMC, emission, immunity

ETSI

650 Route des Lucioles
F-06921 Sophia Antipolis Cedex - FRANCE

Tel.: +33 4 92 94 42 00 Fax: +33 4 93 65 47 16

Siret N° 348 623 562 00017 - NAF 742 C
Association à but non lucratif enregistrée à la
Sous-Préfecture de Grasse (06) N° 7803/88

Important notice

Individual copies of the present document can be downloaded from:

<http://www.etsi.org>

The present document may be made available in more than one electronic version or in print. In any case of existing or perceived difference in contents between such versions, the reference version is the Portable Document Format (PDF). In case of dispute, the reference shall be the printing on ETSI printers of the PDF version kept on a specific network drive within ETSI Secretariat.

Users of the present document should be aware that the document may be subject to revision or change of status. Information on the current status of this and other ETSI documents is available at

<http://portal.etsi.org/tb/status/status.asp>

If you find errors in the present document, send your comment to:

editor@etsi.org

Copyright Notification

No part may be reproduced except as authorized by written permission.
The copyright and the foregoing restriction extend to reproduction in all media.

© European Telecommunications Standards Institute 2003.
All rights reserved.

DECT™, **PLUGTESTS™** and **UMTS™** are Trade Marks of ETSI registered for the benefit of its Members.
TIPHON™ and the **TIPHON logo** are Trade Marks currently being registered by ETSI for the benefit of its Members.
3GPP™ is a Trade Mark of ETSI registered for the benefit of its Members and of the 3GPP Organizational Partners.

Contents

Intellectual Property Rights	4
Foreword.....	4
1 Scope	5
2 References	6
3 Definitions, symbols and abbreviations	7
3.1 Definitions	7
3.2 Symbols.....	8
3.3 Abbreviations	8
4 Transmitter spurious emissions at antenna port	9
4.1 Limits	9
4.1.1 Point-to-point equipments.....	9
4.1.2 Multipoint equipments with fundamental emission below 21,2 GHz.....	9
4.1.3 Multipoint equipments with fundamental emission above 21,2 GHz.....	9
5 Receiver spurious emissions at the antenna port.....	11
6 Spurious emissions test method	11
7 Receivers immunity at antenna port.....	11
7.1 Limits	11
7.2 Receiver immunity test method.....	12
Annex A (informative): Application of CEPT/ERC Recommendation 74-01.....	13
A.1 Frequency range of applicability.....	13
A.2 Level limits.....	14
A.3 Reference bandwidths	14
A.4 Detailed application of the reference bandwidths reported in table A.3	16
A.4.1 P-P and P-MP systems with fundamental emissions from 30 MHz to 1 GHz.....	16
A.4.2 P-P and P-MP systems with fundamental emissions from 1 GHz to 21,2 GHz	16
A.4.3 P-P systems with fundamental emissions above 21,2 GHz.....	17
A.4.4 P-MP systems with fundamental emissions above 21,2 GHz	17
Annex B (informative): Measurement background	18
B.1 Spectrum analyser capability.....	18
B.2 Application examples.....	19
History	26

Intellectual Property Rights

IPRs essential or potentially essential to the present document may have been declared to ETSI. The information pertaining to these essential IPRs, if any, is publicly available for **ETSI members and non-members**, and can be found in ETSI SR 000 314: "*Intellectual Property Rights (IPRs); Essential, or potentially Essential, IPRs notified to ETSI in respect of ETSI standards*", which is available from the ETSI Secretariat. Latest updates are available on the ETSI Web server (<http://webapp.etsi.org/IPR/home.asp>).

Pursuant to the ETSI IPR Policy, no investigation, including IPR searches, has been carried out by ETSI. No guarantee can be given as to the existence of other IPRs not referenced in ETSI SR 000 314 (or the updates on the ETSI Web server) which are, or may be, or may become, essential to the present document.

Foreword

This European Standard (Telecommunications series) has been produced by ETSI Technical Committee Transmission and Multiplexing (TM), and is now submitted for the ETSI standards One-step Approval Procedure.

Proposed national transposition dates	
Date of latest announcement of this EN (doa):	3 months after ETSI publication
Date of latest publication of new National Standard or endorsement of this EN (dop/e):	6 months after doa
Date of withdrawal of any conflicting National Standard (dow):	6 months after doa

1 Scope

The term Spurious emissions is used for simplicity elsewhere in the present document but with the more broader meaning of "*unwanted emissions in the spurious domain*" introduced by ITU-R Recommendation SM.329-10 [1] for clarifying the Radio Regulation definitions and the application of recommended limits for all unwanted emissions; it also recommends that spurious emissions limits apply to all unwanted emissions falling in the spurious domain.

Therefore the present document deals with limits for unwanted emissions in the spurious domain at antenna port of Digital Fixed Radio Systems (DFRS) as defined by ITU-R Recommendation SM.329-10 [1] and CEPT/ERC Recommendation 74-01 [4] and CEPT/ECC Recommendation 02-05 [5].

Moreover it covers immunity characteristics at receiver's antenna port.

Scope of the present document is to define specific limits at antenna port for spurious emissions and receiver immunity for suitable inter-working of Digital Fixed Radio Systems (i.e. Point-to-Point and Multipoint systems) in the same or in different frequency band whenever allocated to Fixed Service in the range 9 kHz to 300 GHz.

However systems with fundamental emission below 30 MHz are not considered relevant for Digital Fixed Radio Systems and are outside the scope of the present document.

Spurious emissions levels and immunity performance at antenna port are also relevant to essential requirements under article 3.2 of Directive 1999/5/EC [15] on Radio equipment and Telecommunication Terminals equipment (R&TTE).

The present document complements CEPT/ERC Recommendation 74-01 [4] which gives Spurious Emissions limits with particular regards to "inter Services" operations, while WG TM4 assumed that in some case more protection is required for compatibility among fixed radio systems deployed in the same geographical area.

Additional considerations and background for producing the present document are:

- Radio Regulations definition of spurious emissions (RR Article 1-145 [16]) is aged and give concept and applicability which do not clearly fit to digital systems; however ITU-R Recommendation SM.329-10 [1] introduced a more useful definition of "*unwanted emissions in the spurious domain*", which should eventually be introduced also into Radio Regulations;
- ITU-R Recommendation SM.329-10 [1] considers emissions from any system, including digital modulation and allows options for the definition of the frequency boundary between out of band domain and spurious emissions domain. It recommends different category of level limits applicable to the Fixed Service;
- ITU-R Recommendation SM.1539.1 [2] describes the application of the boundary concept between out-of-band and spurious emission domains;
- ITU-R Recommendation F.1191-2 [3] define the application of Radio Regulations and SM set of ITU-R Recommendations concepts of out of band, unwanted and spurious emissions to DFRS, clarify the applicability for the boundary between out of band and Spurious emissions domains but maintain the same possible limit options provided by ITU-R Recommendation SM.329-10 [1];
- CEPT/ERC Recommendation 74-01 [4], endorses only the more stringent Category B limits of ITU-R Recommendation SM.329-10 [1];
- after the coming into force of RTTE Directive [15] the emissions and immunity at antenna port fall under its article 3.2 requirements for "*effective use of spectrum*" and "*avoidance of harmful interference*" and they are no longer an EMC requirement;
- considering the large number of TM4 deliverables it is convenient to maintain a single EN covering these parameters instead of replicating them on each single product standard, avoiding possible deviation from what required by other CEPT and ITU-R normative;
- limits for spurious emissions shall be fixed in view of inter-working compatibility among various Fixed Radio Systems in same or different band exploited in the same area;
- the measurement of the required limits should also be feasible in a suitable and cost effective conformance test (annex B gives also information in this field);

- it is necessary that DFRS receivers provide a minimum level of immunity at antenna port towards possible interference at any frequency band of practical interest;
- a suitable and easy to perform criterion for DFRS receivers' immunity at antenna port may be considered the application of a CW interference.

Some ETSI deliverables for DFRS, sometimes, provide limits for both "external" and "internal" spurious emissions and the latter are outside the scope of the present document. Moreover the limits for emissions given in the present document do not prevent more stringent requirement given in those deliverables for intra-system purpose (i.e. local Transmitter to Receiver interference usually referred as "internal").

In order to fix the suitable limits, in annex B, spurious emissions are analysed from the point of view of a suitable test method for conformance testing.

2 References

The following documents contain provisions which, through reference in this text, constitute provisions of the present document.

- References are either specific (identified by date of publication and/or edition number or version number) or non-specific.
- For a specific reference, subsequent revisions do not apply.
- For a non-specific reference, the latest version applies.

Referenced documents which are not found to be publicly available in the expected location might be found at <http://docbox.etsi.org/Reference>.

- [1] ITU-R Recommendation SM.329-10: "Unwanted emissions in the spurious domain".
- [2] ITU-R Recommendation SM.1539-1: "Variation of the boundary between the out-of-band and spurious domains required for the application of Recommendations ITU-R SM.1541 and ITU-R SM.329".
- [3] ITU-R Recommendation F.1191-2: "Bandwidths and unwanted emissions of digital fixed service systems".
- [4] CEPT/ERC Recommendation 74-01 (2002): "Spurious emissions".
- [5] CEPT/ECC Recommendation 02-05 (2002): "Unwanted emissions".
- [6] ETSI EN 301 126-1: "Fixed Radio Systems; Conformance testing; Part 1: Point-to-Point equipment - Definitions, general requirements and test procedures".
- [7] ETSI EN 301 126-2-1: "Fixed Radio Systems; Conformance testing; Part 2-1: Point-to-Multipoint equipment; Definitions and general requirements".
- [8] ETSI EN 301 126-2-2: "Fixed Radio Systems; Conformance testing; Part 2-2: Point-to-Multipoint equipment; Test procedures for FDMA systems".
- [9] ETSI EN 301 126-2-3: "Fixed Radio Systems; Conformance testing; Part 2-3: Point-to-Multipoint equipment; Test procedures for TDMA systems".
- [10] ETSI EN 301 126-2-4: "Fixed Radio Systems; Conformance testing; Part 2-4: Point-to-Multipoint equipment; Test procedures for FH-CDMA systems".
- [11] ETSI EN 301 126-2-5: "Fixed Radio Systems; Conformance testing; Part 2-5: Point-to-Multipoint equipment; Test procedures for DS-SS systems".
- [12] ETSI EN 301 126-2-6: "Fixed Radio Systems; Conformance testing; Part 2-6: Point-to-Multipoint equipment; Test procedures for Multi Carrier Time Division Multiple Access (MC-TDMA) systems".

- [13] ETSI TR 101 036-1: "Fixed Radio Systems; Generic wordings for standards on DFRS (Digital Fixed Radio Systems) characteristics; Part 1: General aspects and point-to-point equipment parameters".
- [14] ITU-R Recommendation F.746-7: "Radio-frequency arrangements for fixed service systems".
- [15] Directive 1999/5/EC of the European Parliament and of the Council of 9 March 1999 on radio equipment and telecommunications terminal equipment and the mutual recognition of their conformity (R&TTE Directive).
- [16] ITU-R Radio Regulations (2001) Article 1.

3 Definitions, symbols and abbreviations

3.1 Definitions

For the purposes of the present document, the following terms and definitions apply:

boundary between out-of-band and spurious domains: frequency limit that subdivides the two domains and the applicability

NOTE: ITU-R Recommendations SM.329-10 [1] and SM.1539-1 [2] describe the possible application to all radio emissions. ITU-R Recommendation F.1191-2 [3] details it for Fixed Service systems.

evaluation bandwidth: bandwidth where the spurious emission limits are measured (e.g. the spectrum analyser resolution bandwidth) for further normalization/integration to the reference bandwidth

out-of-band domain (of an emission): the frequency range, immediately outside the necessary bandwidth but excluding the *spurious domain*, in which *out-of-band emissions* generally predominate

NOTE 1: The terms "out-of-band domain" and "spurious domain" have been introduced in order to remove some inconsistency now existing between, on one hand, the definitions of the terms "out-of-band emission" and "spurious emission" in Article 1 of the RR and, on the other hand, the actual use of these terms in Appendix 3 of the RR, as revised by the World Radiocommunication Conference (WRC-2000). Out-of-band and spurious limits apply, respectively, to all unwanted emissions in the out-of-band and spurious domains.

NOTE 2: Out-of-band emissions, defined based on their source, occur in the out-of-band domain and, to a lesser extent, in the spurious domain. Spurious emissions likewise may occur in the out-of-band domain as well as in the spurious domain.

out of band emissions: ITU-R Recommendation F.1191-2 [3] defines that any unwanted emission, outside the channel bandwidth, which falls at frequencies separated from the centre frequency of the emission by less than 250 % of the relevant channel separation, where the system is intended to be used, will generally be considered out of band emission

NOTE: See also RR Article 1-144 [16] and ITU-R Recommendation SM.329-10 [1] and CEPT/ERC Recommendation 74-01 [4].

receiver spurious emissions: spurious sent backwards to the antenna port by a receiver; sometimes they are also referenced as "spurious radiations"

reference bandwidth: bandwidth where the spurious emission limits are defined, see ITU-R Recommendation SM.329-10 [1]

spurious domain (of an emission): the frequency range beyond the *out-of-band domain* in which *spurious emissions* generally predominate

NOTE: The terms "out-of-band domain" and "spurious domain" have been introduced in order to remove some inconsistency now existing between, on one hand, the definitions of the terms "out-of-band emission" and "spurious emission" in Article 1 of the RR and, on the other hand, the actual use of these terms in Appendix 3 of the RR, as revised by the World Radiocommunication Conference (WRC-2000). Out-of-band and spurious limits apply, respectively, to all unwanted emissions in the out-of-band and spurious domains.

spurious emissions: ITU-R Recommendation F.1191-2 [3] defines that any unwanted emission which falls at frequencies separated from the centre frequency of the emission by 250 % or more of the relevant channel separation, where the system is intended to be used, will generally be considered spurious emission

NOTE: See also RR Article 1-145 [16], ITU-R Recommendation SM.329-10 [1] and CEPT/ERC Recommendation 74-01 [4].

unwanted emissions: They are composed by out of band and spurious emissions. See also RR Article 1-140 [16], ITU-R Recommendations SM.329-10 [1] and F.1191-2 [3].

3.2 Symbols

For the purposes of the present document, the following symbols apply:

dBc	deciBels to carrier mean power
dBm	deciBels to milliwatt
GHz	GigaHertz
kHz	kiloHertz
MHz	MegaHertz

3.3 Abbreviations

For the purposes of the present document, the following abbreviations apply:

ATe	external ATtenuator
ATi	internal spectrum analyser input ATtenuator
ATPC	Automatic Transmission Power Control
BER	Bit Error Rate
BWe	evaluation BandWidth for spectral measurement (i.e. spectrum analyser resolution bandwidth)
BWr	reference BandWidth
CS	Channel Separation
CW	Continuous Wave
DFRS	Digital Fixed Radio Systems
DUT	Device Under Test
Fc	cut-off Frequency
IM	InterModulation
i.m.p.	intermodulation products
MP	MultiPoint (generic term including both P-MP and MP to MP mesh architectures)
MS	Master Station of a P-MP system
P-MP	Point-to-MultiPoint system
P-P	Point-to-Point system
QAM	Quadrature Amplitude Modulation
RF	Radio Frequency
RR	Radio Regulations
RS	Repeater Station (of a P-MP system)
RSL	Receiver Signal Level
Rx	Receiver
TS	Terminal Station (remote out-station with subscriber interface) of a P-MP system
Tx	Transmitter
VSWR	Voltage Standing Wave Ratio

4 Transmitter spurious emissions at antenna port

According to ITU-R Recommendation SM.329-10 [1] and the application to fixed service provided by ITU-R Recommendation F.1191-2 [3], the spurious emissions are defined as emissions at frequencies which are $\pm 250\%$ of the relevant channel separation outside the nominal carrier frequency (spurious emission domain).

According ITU-R Recommendation F.1191-2 [3], the Channel Separation (CS) is taken as $XS/2$ for alternated frequency channel arrangements and XS for co-channel and interleaved frequency channel arrangements as defined by ITU-R Recommendation F.746-7 [14].

The emission within $\pm 250\%$ of the relevant channel separation (out of band domain) includes only fundamental and unwanted emissions in the out of band domain which are outside the scope of the present document.

4.1 Limits

Unless more severe requirement were reported into a specific product ETSI deliverable, the spurious emissions delivered at antenna port, of both transmitter and receiver, of Fixed Radio Systems shall be limited within the average power limits reported below.

For "noise-like" emissions, the limits are intended not to be exceeded in any elementary measuring bandwidth.

The limit values are defined at reference point C' shown in the general RF block diagram of figure 1.

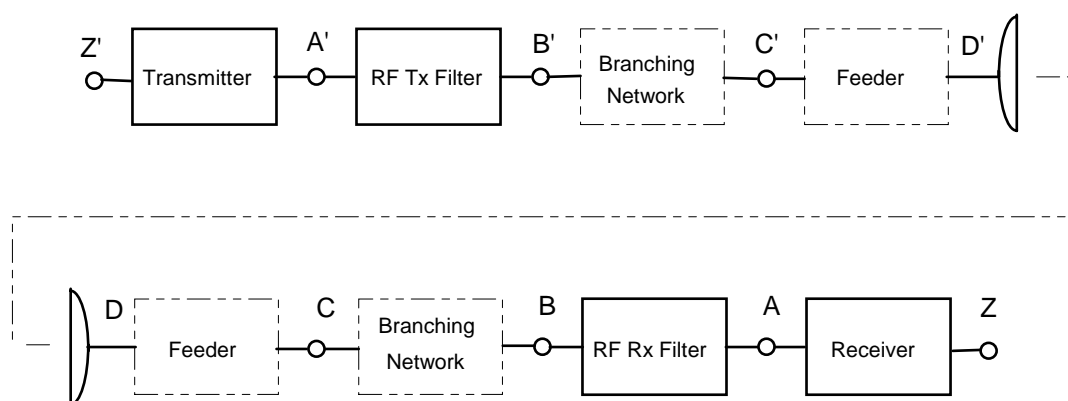

Figure 1: RF block diagram

4.1.1 Point-to-point equipments

The CEPT/ERC Recommendation 74-01 [4] shall apply.

For reader convenience, annex A gives the details for its application to practical systems.

4.1.2 Multipoint equipments with fundamental emission below 21,2 GHz

The CEPT/ERC Recommendation 74-01 [4] shall apply.

For reader convenience, annex A gives the details for its application to practical systems.

4.1.3 Multipoint equipments with fundamental emission above 21,2 GHz

The CEPT/ERC Recommendation 74-01 [4] shall apply as spurious emissions limit in the frequency range 9 kHz to 21,2 GHz and above 43,5 GHz.

For spurious emissions, falling in the range 21,2 GHz to 43,5 GHz, the tighter limits shown in figures 2 and 3 shall apply to both Central and Terminal Stations.

In this frequency range, where the -40 dBm limit shown in figures 2 and 3 apply, allowance is given for no more than 10 discrete (CW) spurious emissions which are permitted to exceed the limit up to -30 dBm.

In the same figures, for comparison, the less stringent limits from CEPT/ERC Recommendation 74-01 [4] are also shown.

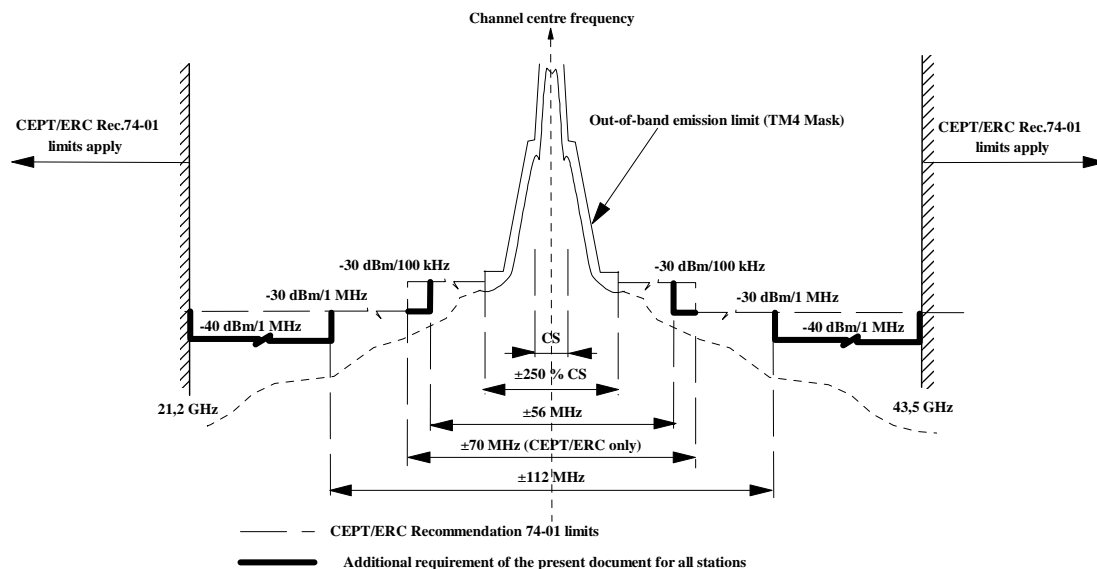

Figure 2: MP equipments for channel separation $1 < \text{CS} \leq 10$ MHz

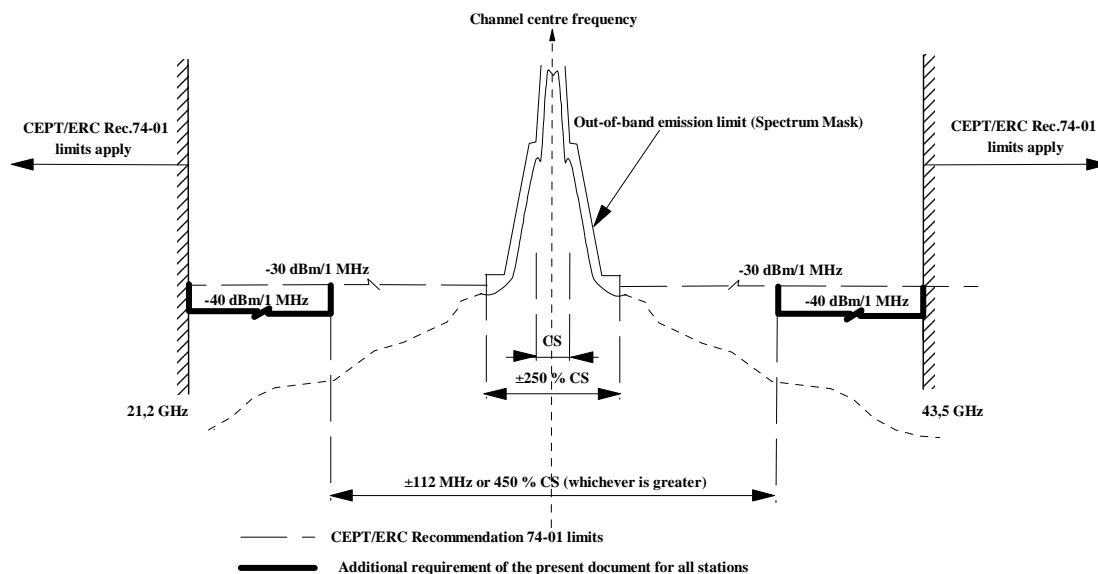

Figure 3: MP equipments for channel separation $\text{CS} > 10$ MHz

5 Receiver spurious emissions at the antenna port

Receiver spurious emissions are defined in the same frequency range of transmitters spurious emissions, without any exclusion band (such as the 250 % of the relevant channel separation) and are applicable at the reference point C of figure 1.

The CEPT/ERC Recommendation 74-01 [4] shall apply.

6 Spurious emissions test method

The measurement shall be referenced at the Tx/Rx common antenna port (reference points C-C' of figure 1).

According to the equipment physical construction, the test shall be carried on with the methodologies given in EN 301 126-1 [6] and EN 301 126-2-1 [7], EN 301 126-2-2 [8], EN 301 126-2-3 [9], EN 301 126-2-4 [10], EN 301 126-2-5 [11] and EN 301 126-2-6 [12]. The measurement shall be carried out with transmitters set to the higher level of continuous emission (see note) with the payloads inputs connected to a suitable test pattern, defined, for the equipment under consideration, in the applicable ETSI deliverable, if available, or by manufacturer declaration.

In order to provide easy and cost effective Conformance Test, the measurement may be carried out with wider BWe, provided that the results will be normalized to the required bandwidth with the methods reported in ITU-R Recommendation F.1191-2 [3] and CEPT/ERC Recommendation 74-01 [4].

NOTE: With ATPC disabled and set to the higher emission power.

7 Receivers immunity at antenna port

7.1 Limits

A suitable and easy to perform criterion is considered the application of a CW interference.

CW spurious response rejection ratio of a receiver is a measure of its ability to discriminate between the wanted signal at the nominal channel frequency of the receiver and an unwanted signal at any other frequency at which a response is obtained.

Unless more severe requirement were reported into a specific product ETSI deliverable, for a receiver operating at a RSL corresponding to the nominal 10^{-6} BER threshold given by the relevant ETSI deliverable or in their vacancy by the Manufacturer declaration, the introduction of a CW interferer with respect to the "wanted" signal of:

- a) for Point-to-point equipment operating on channel spacing lower than or equal to 14 MHz:
 - +20 dB at any frequency either side of the wanted centre frequency of the RF channel from 250 % up to 500 % the channel spacing;
 - +30 dB outside 500 % the channel spacing;
- b) for Point-to-point equipment operating on channel spacing greater than 14 MHz:
 - +30 dB at any frequency either side of the wanted centre frequency of the RF channel outside 250 % of the channel spacing;
- c) for Multipoint equipment:
 - +30 dB at any frequency either side of the wanted centre frequency of the RF channel outside 550 % of the channel spacing;

shall not result in a BER greater than 10^{-5} .

NOTE 1: This requirement is considered equivalent to a degradation of 1 dB of the 10^{-6} BER threshold.

The requirement above shall be fulfilled at any frequency in the range given in table 1 (see note 2).

NOTE 2: In any case, systems having an integral antenna incorporating a waveguide section, or with an antenna connection in such form, and of length equal to at least twice the cut-off wavelength, should not require receiver immunity measurement below 0,7 times the waveguide cut-off frequency.

Table 1

Fundamental receiver frequency range	CW Spurious Response frequency range	
	Lower frequency	Upper frequency (see note)
9 kHz to 100 MHz	9 kHz	1 GHz
100 MHz to 300 MHz	9 kHz	10 th harmonic
300 MHz to 600 MHz	30 MHz	3 GHz
300 MHz to 5,2 GHz	30 MHz	5 th harmonic
5,2 GHz to 13 GHz	30 MHz	26 GHz
13 GHz to 150 GHz	30 MHz	2 nd harmonic
150 GHz to 300 GHz	30 MHz	300 GHz

NOTE: The test should include the entire harmonic band and not be truncated at the precise upper frequency limit stated.

The above kind of immunity does not exclude other more demanding requirement of a specific product (pr)ETSI deliverable, if any.

7.2 Receiver immunity test method

The measurement shall be referenced at the Tx/Rx common antenna port (reference points C-C' of figure 1).

According to the equipment physical construction, the test shall be carried on with the methodologies given in EN 301 126-1 [6] and EN 301 126-2-1 [7], EN 301 126-2-2 [8], EN 301 126-2-3 [9], EN 301 126-2-4 [10] and EN 301 126-2-5 [11].

Annex A (informative): Application of CEPT/ERC Recommendation 74-01

The limits of the spurious emissions required by the present document are reported in CEPT/ERC Recommendation 74-01 [4]; however, for reader convenience, relevant limits of this recommendation are reported below in relation to those required by the present document.

A.1 Frequency range of applicability

According to ITU-R Recommendation SM.329-10 [1] and the application to fixed service provided by ITU-R Recommendation F.1191-2 [3], CEPT/ERC Recommendation 74-01 [4] defines spurious emissions as any emission at frequencies which are outside the nominal carrier frequency by more than $\pm 250\%$ of the relevant channel separation.

The CEPT/ERC Recommendation 74-01 [4] requires that the limits on spurious emissions for radio equipments are considered here to be applicable to the range 9 kHz to 300 GHz. However, for practical measurement purpose only, the frequency range of spurious emissions may be restricted. As guidance for practical purposes, the measurement parameters reported in table A.1 are normally recommended by CEPT/ERC Recommendation 74-01 [4].

Table A.1

Fundamental frequency range	Spurious frequency range	
	Lower frequency	Upper frequency (see note)
9 kHz to 100 MHz	9 kHz	1 GHz
100 MHz to 300 MHz	9 kHz	10 th harmonic
300 MHz to 600 MHz	30 MHz	3 GHz
300 MHz to 5,2 GHz	30 MHz	5 th harmonic
5,2 GHz to 13 GHz	30 MHz	26 GHz
13 GHz to 150 GHz	30 MHz	2 nd harmonic
150 GHz to 300 GHz	30 MHz	300 GHz

NOTE: The test should include the entire harmonic band and not be truncated at the precise upper frequency limit stated.

These parameters reflect the increasing difficulty in undertaking practicable tests, especially at frequencies approaching or beyond 110 GHz, taking into account such factors as availability and usability of suitable measurement equipment. In some circumstances, it may be necessary to extend the range of test frequencies in order to better facilitate protection of other services such as radioastronomy. In any case, systems having an integral antenna incorporating a waveguide section, or with an antenna connection in such form, and of length equal to at least twice the cut-off wavelength, should not require spurious emissions measurement below 0,7 times the waveguide cut-off frequency.

For "noise-like" emissions, the limits are intended not to be exceeded in any elementary measuring bandwidth.

A.2 Level limits

The CEPT/ERC Recommendation 74-01 [4] requires the limits reported in table A.2.

Table A.2

SPURIOUS DOMAIN EMISSION LIMITS FOR SYSTEMS IN THE FIXED SERVICE	
Type of equipment	Limits mean power or, when applicable, average power during bursts duration in the reference bandwidth
Fixed Service - Transmitters (all stations except those below)	-50 dBm, for 9 kHz (note 3) $\leq f \leq 21,2$ GHz (note 1) -30 dBm, for 21,2 GHz $< f \leq F_{UPP}$ (see clause A.1) (notes 1 and 4)
Fixed Service - Terminal Stations (remote stations with subscriber equipment interfaces) (note 2)	-40 dBm, for 9 kHz (note 3) $\leq f \leq 21,2$ GHz (note 1) -30 dBm, for 21,2 GHz $< f \leq F_{UPP}$ (see clause A.1) (notes 1 and 4)
Fixed Service - Receivers	The same limits as for the transmitters above apply
<p>NOTE 1: For digital systems it is necessary to provide one or more steps of reference bandwidth to produce suitable transition area for the spectral density to manage the required limit because in some frequency bands and/or applications narrow-band RF filters are not technically or economically feasible. Consequently, just outside the ± 250 % of the relevant Channel Separation, the limit of spurious domain emissions are defined with reference bandwidths as detailed by the specific figure A.1 and the related table A.3.</p> <p>NOTE 2: Point-to-Multipoint systems used in CEPT countries foresee three kinds of stations: - MS Master (Central) Station (clearly identifiable in ITU-R Recommendation SM.329-10 [1]); - TS Terminal Station (also clearly identifiable in ITU-R Recommendation SM.329-10 [1]); - RS Repeater Station (which is not referred in ITU-R Recommendation SM.329-10 [1]). Repeater Stations of Point-to-multipoint systems will be considered as Terminal Stations when they are intended for use only in Remote stations not co-located with any other Fixed radio equipment classified as Central station. When considering Multipoint-to-Multipoint (mesh) access systems, Multipoint-to-Multipoint stations providing co-frequency coverage to a defined area, without addressing any specific Terminal Station (in terms of antenna radiation pattern), should be considered as Master Station.</p> <p>NOTE 3: In ITU-R Recommendation SM.329-10 [1] from 9 kHz to 30 MHz only Category A limits (i.e. -13 dBm) apply also when Category B is selected, however CEPT will propose revision to ITU-R Recommendation SM.329-10 [1] in order to extend Category B limits down to 9 kHz.</p> <p>NOTE 4: It is recognized that, for Multipoint systems, with fundamental operating frequency higher than 21,2 GHz, EN 301 390 identifies that the limits, reported in CEPT/ERC Recommendation 74-01 [4], developed at earlier stage, are not enough stringent in the HDFS bands (21,2 GHz to 43,5 GHz) in order to safely deploy the large foreseen number of systems. Therefore, in developing the Harmonized Standards under Directive 1999/5/EC (R&TTE Directive) [15] for Multipoint systems, the more stringent limits, reported in EN 301 390 for those bands, have been adopted among essential requirements under article 3.2 of the R&TTE Directive [15].</p>	

When burst transmission is used, the mean power of any spurious emissions is measured using power averaging over the burst duration.

A.3 Reference bandwidths

The following reference bandwidths are recommended by the CEPT/ERC Recommendation 74-01 [4]:

- 1 kHz for spurious emissions falling between 9 kHz and 150 kHz;
- 10 kHz for spurious emissions falling between 150 kHz and 30 MHz;
- 100 kHz for spurious emissions falling between 30 MHz and 1 GHz;
- 1 MHz for spurious emissions falling above 1 GHz.

However, because in some frequency bands and/or applications narrow band RF filters are not technically or economically feasible, it is necessary to provide one or more steps of reference bandwidth to produce suitable transition area for the spectral density to manage the required limit.

Consequently, just outside the $\pm 250\%$ of the relevant channel spacing, the limit of spurious emissions are defined within the reference bandwidths detailed in the following figure A.1 and table A.3 in a comprehensive form.

NOTE: The reference bandwidths in figure A.1 and table A.3 are not applicable to receiver spurious emissions.

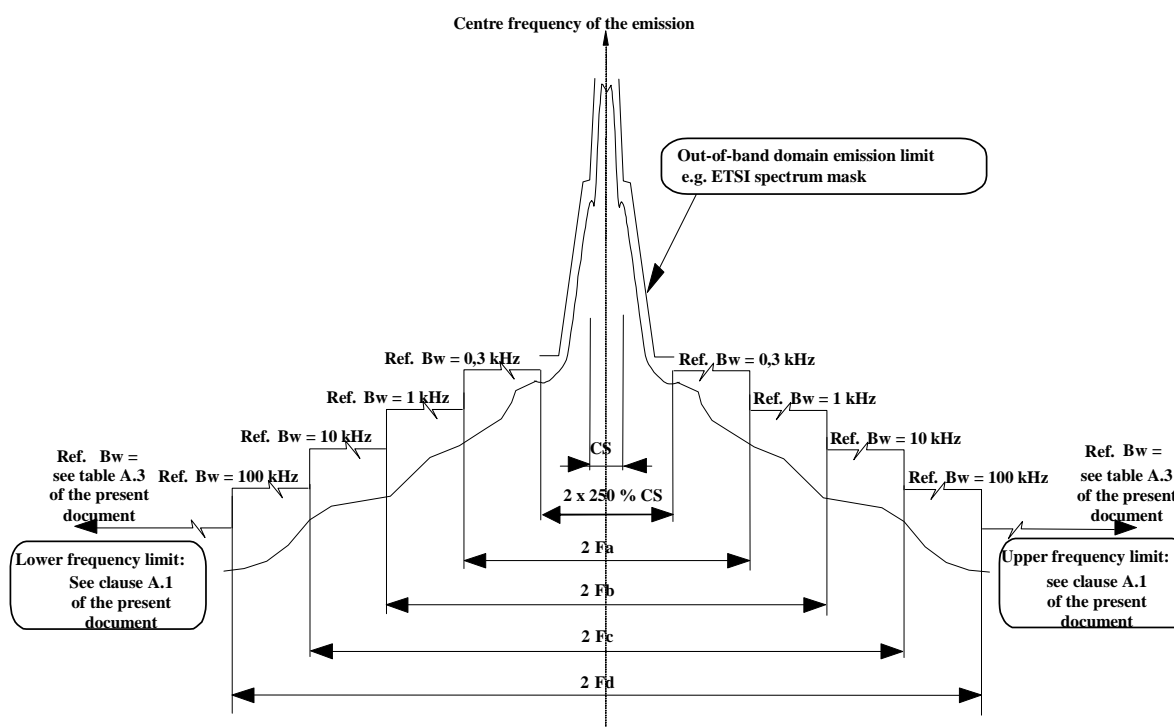

NOTE: $\pm F_d$ frequency steps are not applicable if lower than 1 GHz;
 $\pm F_c$ frequency steps are not applicable if lower than 30 MHz;
 $\pm F_b$ frequency steps are not applicable if lower than 150 kHz.

Figure A.1: Generic spurious emission reference bandwidth limits mask (ref. to table A.3)

Table A.3

Fundamental emission Frequency	Channel Spacing (CS) [MHz]	Typical Symbol Rate [-Mbaud/s]	BW _r 0,3 kHz F _a [MHz]	BW _r 1 kHz F _b [MHz]	BW _r 10 kHz F _c [MHz]	BW _r 100 kHz F _d [MHz]
Below 21,2 GHz	$0,01 \leq CS < 1$	$F_s \cong 0,06 \div 0,8$	-	-	14	28
(Terminal Stations)	$1 \leq CS < 10$	$F_s \cong 0,6 \div 8$	-	-	28	70
	$CS \geq 10$	$F_s \sim > 6$	-	-	49 (note 1)	70 (note 1)
Below 21,2 GHz	$0,01 \leq CS < 1$	$F_s \cong 0,06 \div 0,8$	3,5	7	14	28
(Other stations)	$1 \leq CS < 10$	$F_s \cong 0,6 \div 8$	-	14 (note 1)	28	70
	$CS \geq 10$	$F_s \sim > 6$	-	-	49 (note 1)	70 (note 1)
Above 21,2 GHz	$1 \leq CS < 10$	$F_s \cong 0,6 \div 8$	-	-	-	70
(All stations) (note 2)	$CS \geq 10$	$F_s \sim > 6$	-	-	-	-

NOTE 1: Not applicable where the 250 % of CS exceed these values.

NOTE 2: The CEPT/ERC Recommendation 74-01 [4] do not make distinction for stations operating above 21,2 GHz, however for the purpose of the present document, the more stringent limits of clause 4.1.3 apply to P-MP systems only.

NOTE 3: It is recognized that, depending on the characteristic of the emissions, the actual power density relative to the ETSI mask at the $\pm 250\%$ boundary, when evaluated in the reference bandwidth of one or more steps of table A.3, may be lower than the spurious emission limit itself. In such cases these steps are not applicable and the first applicable spurious emission reference bandwidth step, which corresponds to a power density equal or lower than that evaluated with the ETSI mask in the same reference bandwidth, should be extended back to the $\pm 250\%$ boundary (examples of this concept is shown in clause B.2 (figures B.4, B.7, B.9 and B.11)).

A.4 Detailed application of the reference bandwidths reported in table A.3

The above generic figures are detailed for the different ranges of transmitter fundamental emissions as follows.

A.4.1 P-P and P-MP systems with fundamental emissions from 30 MHz to 1 GHz

a) BW_r is taken equal to 0,3 kHz for:

- $0,01 \leq CS < 1$ MHz in the range from ± 250 % of CS to $\pm 3,5$ MHz.

NOTE 1: Not applicable to TS and RS remote out-stations for which the -40 dBm limit apply.

b) BW_r is taken equal to 1 kHz for:

- $0,01 \leq CS < 1$ MHz in the range from $\pm 3,5$ MHz to ± 7 MHz; and for
- $1 \text{ MHz} \leq CS < 5,6$ MHz in the range from ± 250 % of channel spacing to ± 14 MHz.

NOTE 2: Not applicable to TS and RS remote out-stations for which the -40 dBm limit apply.

c) BW_r is taken equal to 10 kHz for:

- Terminal Stations, for which the -40 dBm limit apply, for:
 - $0,01 \leq CS < 1$ MHz in the range from ± 250 % of CS to ± 14 MHz; for
 - $1 \text{ MHz} \leq CS < 10$ MHz in the range from ± 250 % of CS to ± 28 MHz; and for
 - $10 \text{ MHz} \leq CS < 19,6$ MHz in the range from ± 250 % of CS to ± 49 MHz.
- other stations for:
 - $0,01 \leq CS < 1$ MHz in the range from 7 MHz to ± 14 MHz; for
 - $1 \text{ MHz} \leq CS < 5,6$ MHz in the range from ± 14 MHz to ± 28 MHz; for
 - $5,6 \text{ MHz} \leq CS < 10$ MHz in the range from ± 250 % of CS to ± 28 MHz; and for
 - $10 \text{ MHz} \leq CS < 19,6$ MHz in the range from ± 250 % of CS to ± 49 MHz.

A.4.2 P-P and P-MP systems with fundamental emissions from 1 GHz to 21,2 GHz

a) BW_r shall be taken equal to 0,3 kHz for:

- $0,01 \leq CS < 1$ MHz in the range from ± 250 % of CS to $\pm 3,5$ MHz.

NOTE 1: Not applicable to TS and RS remote out-stations for which the -40 dBm limit apply.

b) BW_r shall be taken equal to 1 kHz for:

- $0,01 \leq CS < 1$ MHz in the range from $\pm 3,5$ MHz to ± 7 MHz; and for
- $1 \text{ MHz} \leq CS < 5,6$ MHz in the range from ± 250 % of channel spacing to ± 14 MHz.

NOTE 2: Not applicable to TS and RS remote out-stations for which the -40 dBm limit apply.

- c) BW_r shall be taken equal to 10 kHz for:
- Terminal Stations for which the -40 dBm limit apply for:
 - $0,01 \leq CS < 1$ MHz in the range from ± 250 % of CS to ± 14 MHz; for
 - $1 \text{ MHz} \leq CS < 10$ MHz in the range from ± 250 % of CS to ± 28 MHz; and for
 - $10 \text{ MHz} \leq CS < 19,6$ MHz in the range from ± 250 % of CS to ± 49 MHz.
 - other stations for:
 - $0,01 \leq CS < 1$ MHz in the range from 7 MHz to ± 14 MHz; for
 - $1 \text{ MHz} \leq CS < 5,6$ MHz in the range from ± 14 MHz to ± 28 MHz; for
 - $5,6 \text{ MHz} \leq CS < 10$ MHz in the range from ± 250 % of CS to ± 28 MHz; and for
 - $10 \text{ MHz} \leq CS < 19,6$ MHz in the range from ± 250 % of CS to ± 49 MHz.
- d) BW_r shall be taken equal to 100 kHz for:
- $0,01 \leq CS < 1$ MHz in the range from ± 14 MHz to ± 28 MHz; for
 - $1 \text{ MHz} \leq CS < 10$ MHz in the range from ± 28 MHz to ± 70 MHz; for
 - $10 \text{ MHz} \leq CS < 19,6$ MHz in the range from ± 49 MHz to ± 70 MHz; and for
 - $19,6 \text{ MHz} \leq CS < 28$ MHz in the range from ± 250 % of CS to ± 70 MHz.

A.4.3 P-P systems with fundamental emissions above 21,2 GHz

BW_r shall be taken equal to 100 kHz for:

- $1 \text{ MHz} \leq CS < 10$ MHz in the range from ± 250 % of CS to ± 70 MHz.

A.4.4 P-MP systems with fundamental emissions above 21,2 GHz

For these systems the CEPT/ERC Recommendation is less stringent than the present document, therefore the reader is demanded to clause 4.1.3.

Annex B (informative): Measurement background

B.1 Spectrum analyser capability

The generic set-up for emissions measurement is shown in figure B.1.

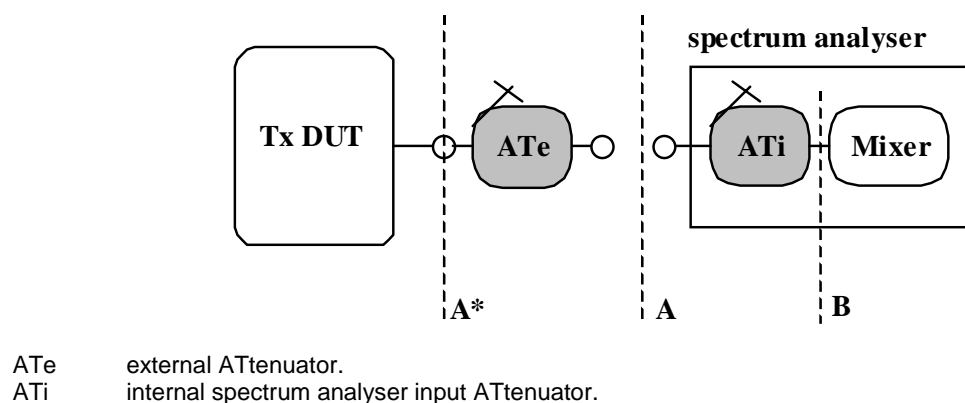

Figure B.1: Spectrum measurement test schematic

When digital modulation are concerned the available limits of measurement from a spectrum analyser are to be taken into account (see TR 101 036-1 [13]).

The following limitation for the spectrum analyser measurement applies depending on the characteristic of the instrument used:

- 1) B_{3rd} : Safe average input level at point B for distortion (at mixer input) (e.g. third order intermodulation reduction > 50 dBc);
- 2) B_{Max} : Max. input level at point B (e.g. with 10 dB attenuation for VSWR opt.);
- 3) minimum displayed absolute level of the equivalent noise floor at A* point:
 - with > 50 dBc i.m.p. = Min displ. noise at A + (ATi + ATe);
= Min displ. noise at A + (Pout - B_{3rd}).
 - absolute minimum (with 10 dB Att. for VSWR):
= Min displ noise at A + (Pout - B_{Max});
or (whichever is greater);
= Min displ. noise at A + 10 dB.

B.2 Application examples

The following figures show applications of the limits provided by the present document and other above described limits to some common TM4 deliverables spectrum masks.

The relevant ETSI deliverable reports the spectrum mask(s) defined to limit the out of band portion of the emission (i.e. within the $\pm 250\%$ of the relevant CS) together with the recommended reference bandwidth for conformance test purpose; however to visualize how the out of band portion of the spectral density fits to the spurious emissions limit at their boundary, the relative spectrum mask and the actual output power may be used to normalize the mask into a power density within the reference bandwidth where the first step of spurious emissions limit is defined.

NOTE: For discrete components of spurious emissions this normalization is not effective provided that their limit is independent from the reference bandwidth.

The output power of the systems (necessary to evaluate the absolute level of the signal spectral density and to set the values of the attenuators AT1i and ATe) has been taken as a typical achievable level in the relevant frequency band.

In the following figures two noise floor limits of spectrum analyser are shown and marked with explanatory notes.

The noise floor limit with > 50 dB i.m.p. has been shown for example only, however in practice it may be necessary for near carrier measurement of QAM systems only, not to impair the precision. Others have to be evaluated case by case (see TR 101 036-1 [13] for background in this field).

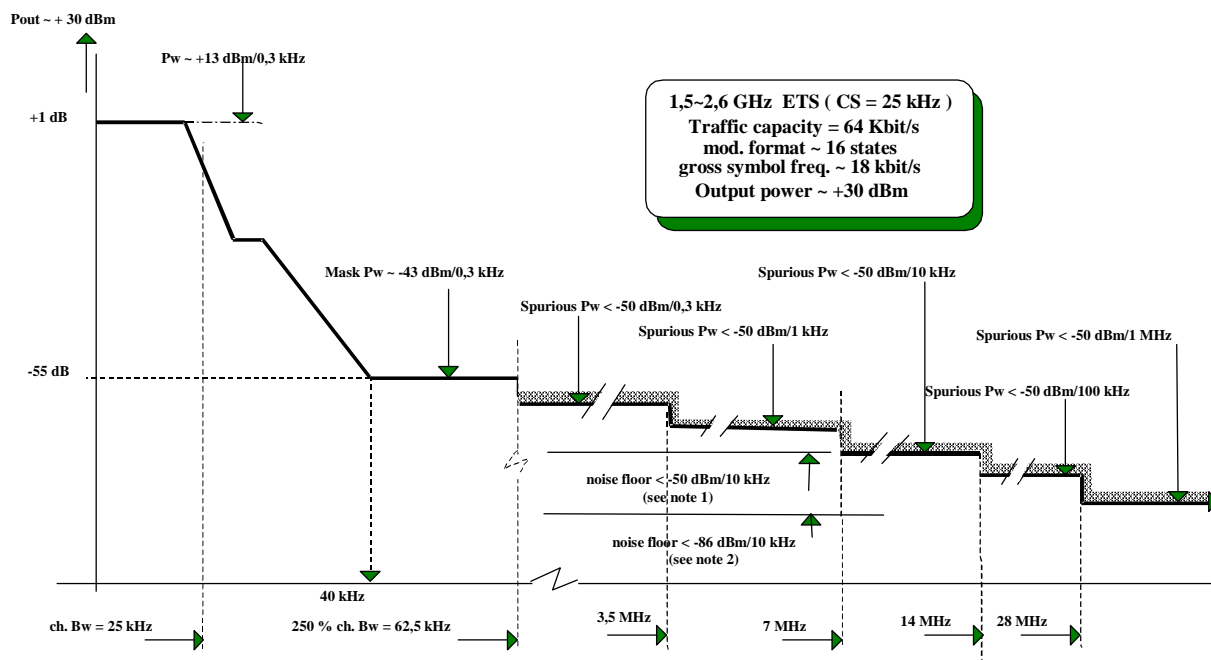

NOTE 1: Typical noise floor with 3rd order i.m.p. > 50 dB.
 NOTE 2: Typical noise floor with maximum input level (highest dynamic range).

Figure B.2

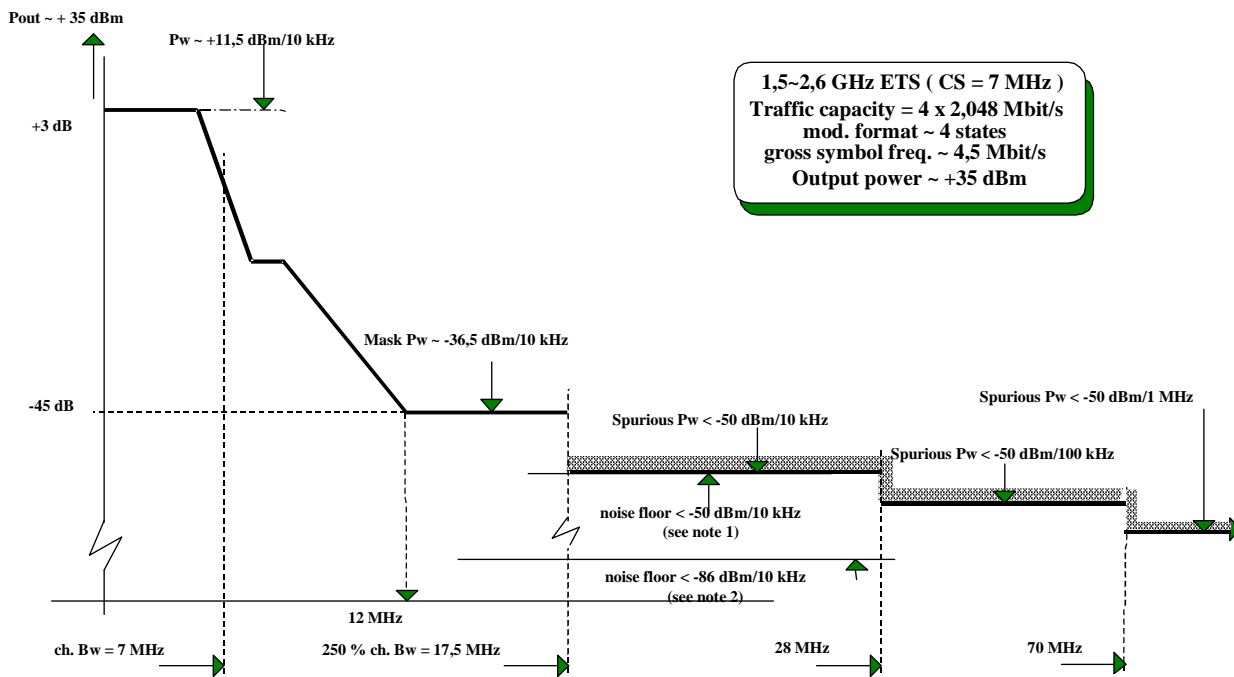

NOTE 1: Typical noise floor with 3rd order i.m.p. > 50 dB.
 NOTE 2: Typical noise floor with maximum input level (highest dynamic range).

Figure B.3

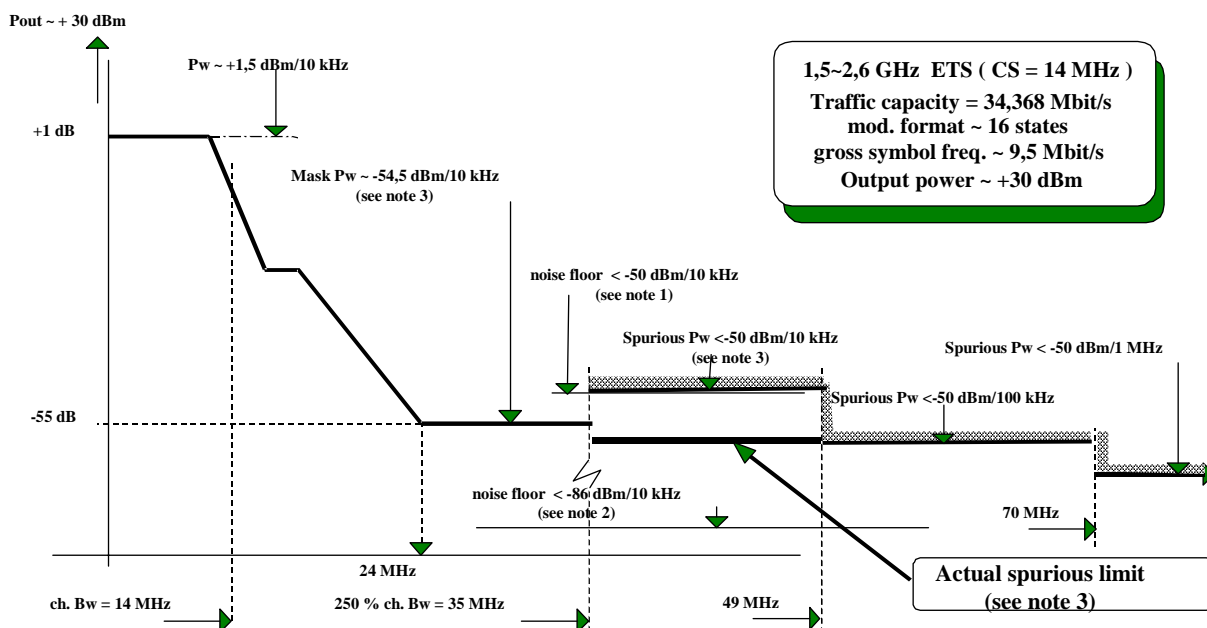

NOTE 1: Typical noise floor with 3rd order i.m.p. > 50 dB.
 NOTE 2: Typical noise floor with maximum input level (highest dynamic range).
 NOTE 3: Example of reference bandwidth step not applicable (see note 3 in table A.3).

Figure B.4

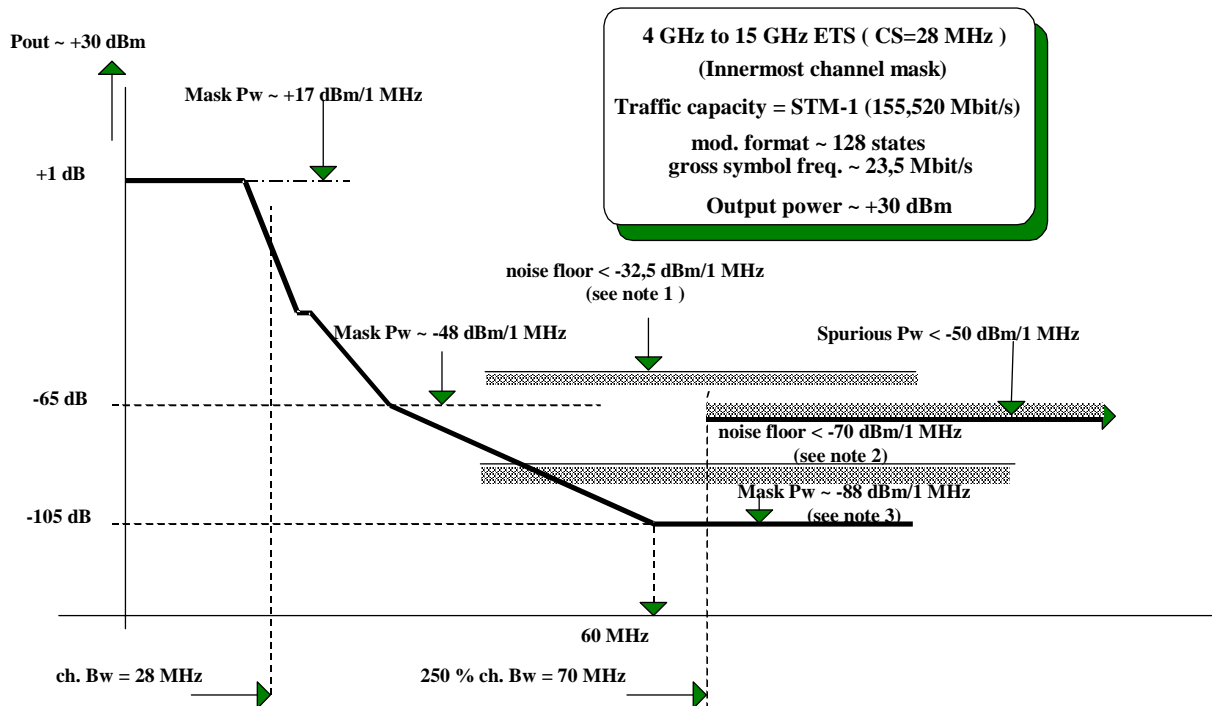

NOTE 1: Typical noise floor with 3rd order i.m.p. > 50 dB.

NOTE 2: Typical noise floor with maximum input level (highest dynamic range).

NOTE 3: Above 70 MHz intra system compatibility only.

Figure B.5

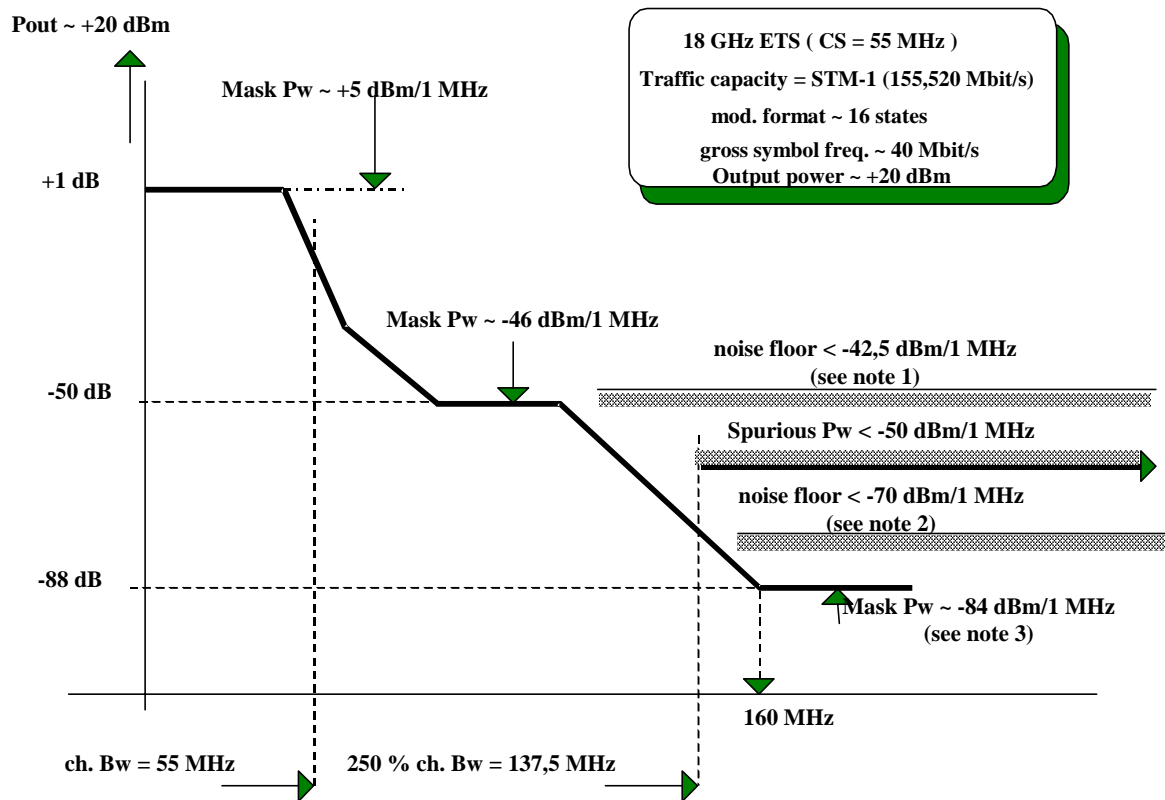

NOTE 1: Typical noise floor with 3rd order i.m.p. > 50 dB.

NOTE 2: Typical noise floor with maximum input level (highest dynamic range).

NOTE 3: Intra system compatibility only.

Figure B.6

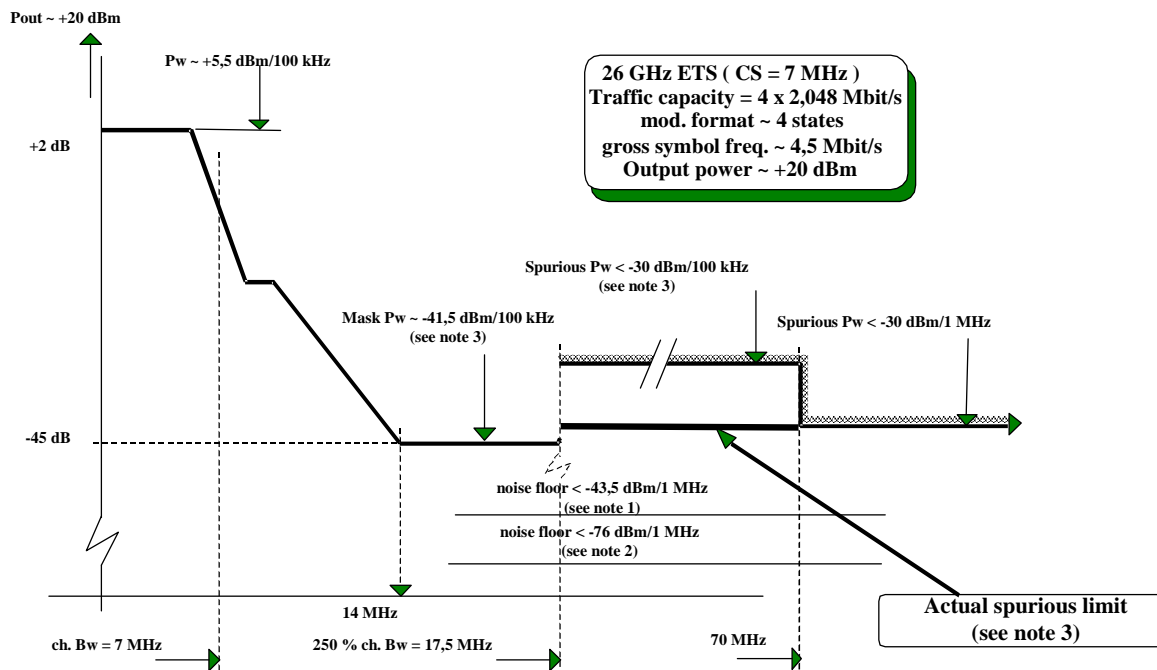

NOTE 1: Typical noise floor with 3rd order i.m.p. > 50 dB.
 NOTE 2: Typical noise floor with maximum input level (highest dynamic range).
 NOTE 3: Example of reference bandwidth step not applicable (see note 3 in table A.3).

Figure B.7

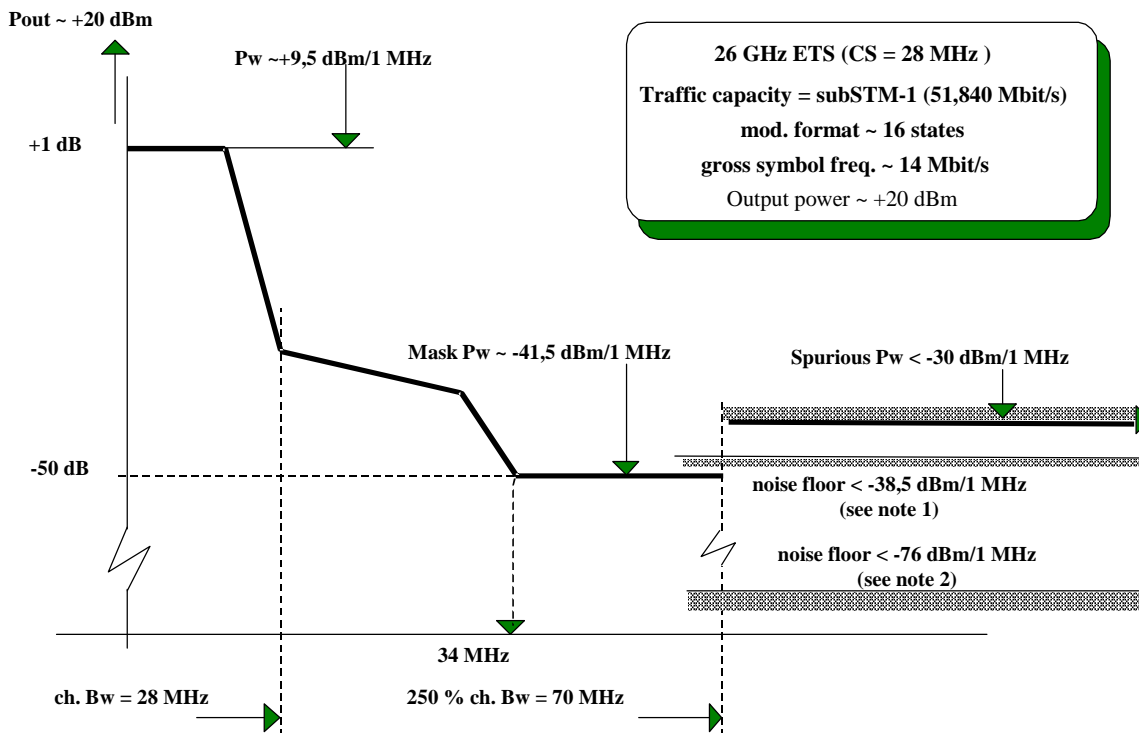

NOTE 1: Typical noise floor with 3rd order i.m.p. > 50 dB.
 NOTE 2: Typical noise floor with maximum input level (highest dynamic range).

Figure B.8

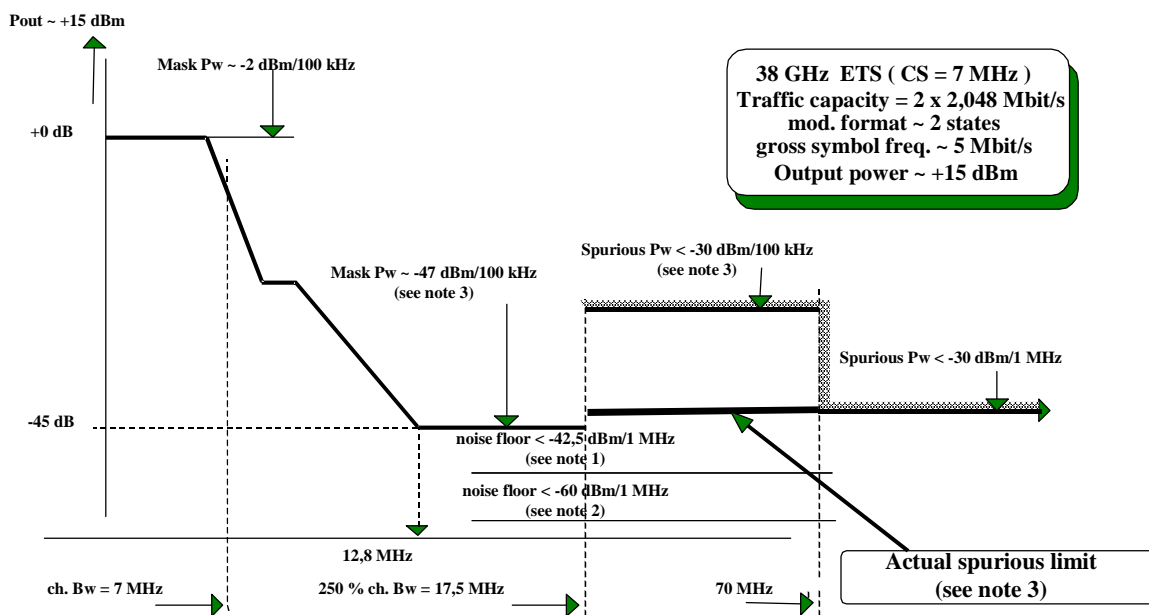

NOTE 1: Typical noise floor with 3rd order i.m.p. > 50 dB.
 NOTE 2: Typical noise floor with maximum input level (highest dynamic range).
 NOTE 3: Example of reference bandwidth step not applicable (see note 3 in table A.3).

Figure B.9

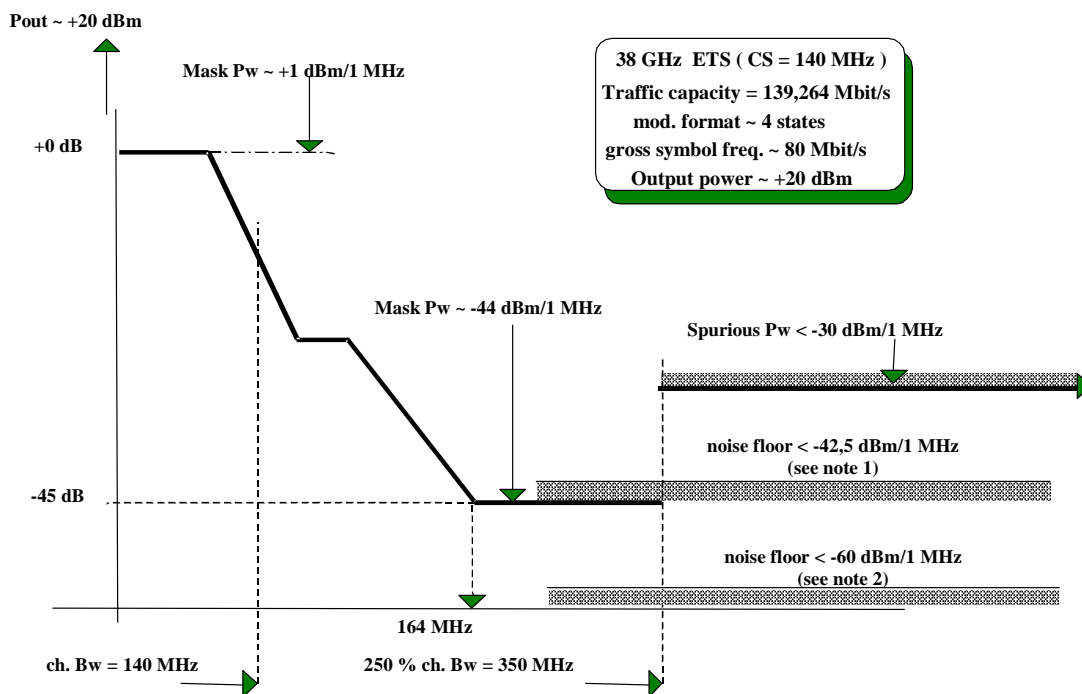

NOTE 1: Typical noise floor with 3rd order i.m.p. > 50 dB.
 NOTE 2: Typical noise floor with maximum input level (highest dynamic range).

Figure B.10

History

Document history		
V1.1.1	December 2000	Publication
V1.2.1	July 2003	One-step Approval Procedure OAP 20031121: 2003-07-23 to 2003-11-21