

# ETSI EN 301 390 V1.1.1 (2000-12)

---

*European Standard (Telecommunications series)*

**Fixed Radio Systems;  
Point-to-point and Point-to-Multipoint Systems;  
Spurious emissions and receiver immunity at  
equipment/antenna port of Digital Fixed Radio Systems**

---

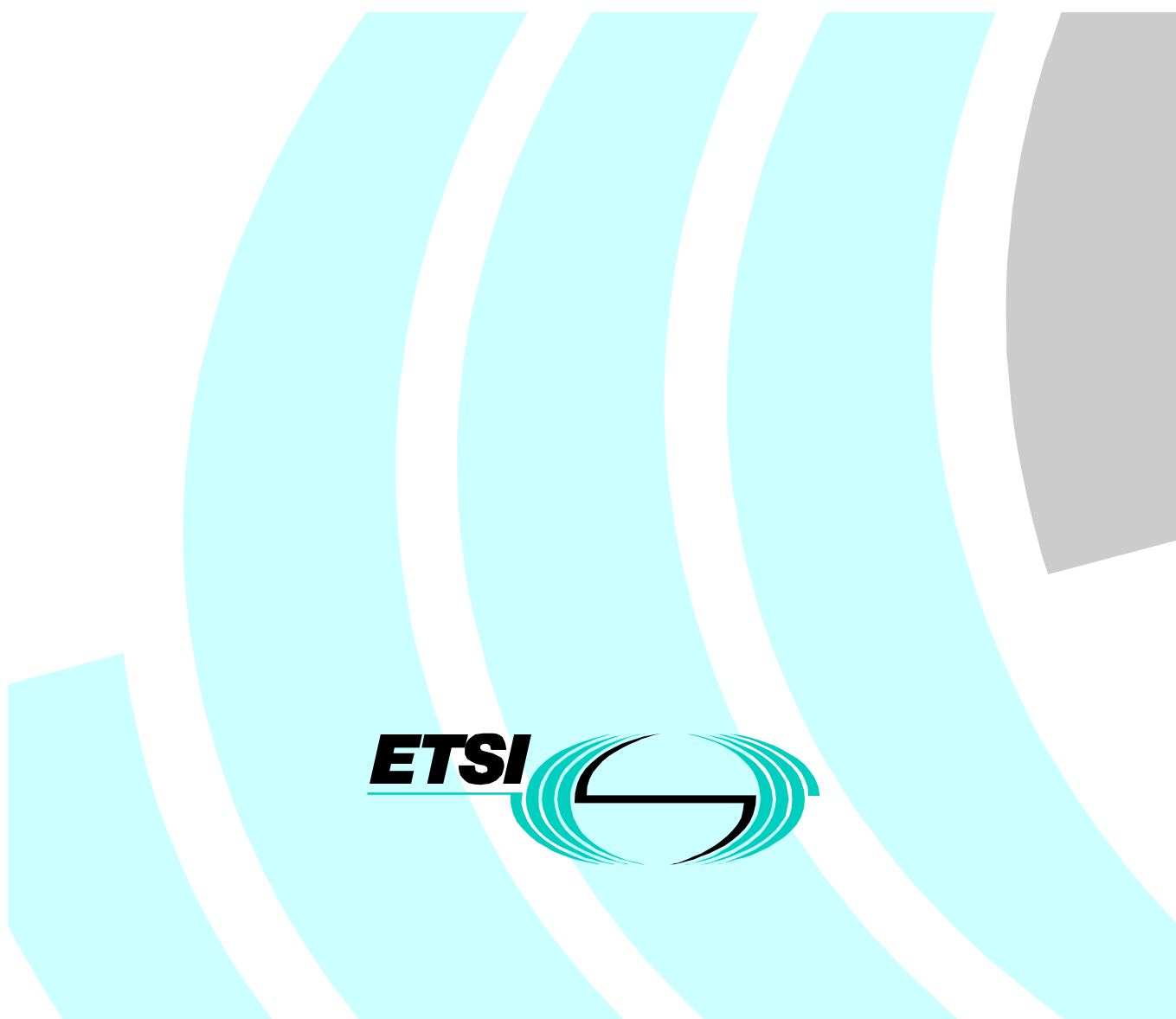

---

**Reference**

DEN/TM-04040

---

**Keywords**

antenna, DRRS, EMC, emission, immunity

**ETSI**

650 Route des Lucioles  
F-06921 Sophia Antipolis Cedex - FRANCE

---

Tel.: +33 4 92 94 42 00 Fax: +33 4 93 65 47 16

Siret N° 348 623 562 00017 - NAF 742 C  
Association à but non lucratif enregistrée à la  
Sous-Préfecture de Grasse (06) N° 7803/88

---

**Important notice**

---

Individual copies of the present document can be downloaded from:

<http://www.etsi.org>

The present document may be made available in more than one electronic version or in print. In any case of existing or perceived difference in contents between such versions, the reference version is the Portable Document Format (PDF). In case of dispute, the reference shall be the printing on ETSI printers of the PDF version kept on a specific network drive within ETSI Secretariat.

Users of the present document should be aware that the document may be subject to revision or change of status. Information on the current status of this and other ETSI documents is available at <http://www.etsi.org/tb/status/>

If you find errors in the present document, send your comment to:  
editor@etsi.fr

---

**Copyright Notification**

---

No part may be reproduced except as authorized by written permission.  
The copyright and the foregoing restriction extend to reproduction in all media.

© European Telecommunications Standards Institute 2000.  
All rights reserved.

# Contents

Intellectual Property Rights .....	4
Foreword .....	4
1 Scope.....	5
2 References .....	6
3 Definitions, symbols and abbreviations .....	7
3.1 Definitions .....	7
3.2 Symbols .....	7
3.3 Abbreviations.....	7
4 Transmitter spurious emissions at antenna port .....	8
4.1 Limits .....	8
4.1.1 Point-to-point equipments .....	9
4.1.2 Point-to-multipoint equipments with fundamental emission below 21,2 GHz .....	9
4.1.3 Point-to-multipoint equipments with fundamental emission above 21,2 GHz.....	9
5 Receiver spurious emissions at the antenna port .....	10
6 Spurious emissions test method.....	10
7 Receivers immunity at antenna port .....	11
7.1 Limits .....	11
7.2 Receiver immunity test method.....	11
<b>Annex A (informative): Application of CEPT/ERC Recommendation 74-01 .....</b>	<b>12</b>
A.1 Frequency range of applicability .....	12
A.2 Level limits.....	13
A.3 Reference bandwidths .....	13
A.4 Detailed application of the reference bandwidths reported in table A.3 .....	15
A.4.1 P-P and P-MP systems with fundamental emissions from 30 MHz to 1 GHz.....	15
A.4.2 P-P and P-MP systems with fundamental emissions from 1 GHz to 21,2 GHz .....	15
A.4.3 P-P systems with fundamental emissions above 21,2 GHz.....	16
A.4.4 P-MP systems with fundamental emissions above 21,2 GHz .....	16
<b>Annex B (informative): Measurement background.....</b>	<b>17</b>
B.1 Spectrum analyser capability.....	17
B.2 Application examples .....	17
History .....	23

---

## Intellectual Property Rights

IPRs essential or potentially essential to the present document may have been declared to ETSI. The information pertaining to these essential IPRs, if any, is publicly available for **ETSI members and non-members**, and can be found in ETSI SR 000 314: "*Intellectual Property Rights (IPRs); Essential, or potentially Essential, IPRs notified to ETSI in respect of ETSI standards*", which is available from the ETSI Secretariat. Latest updates are available on the ETSI Web server (<http://www.etsi.org/ipr>).

Pursuant to the ETSI IPR Policy, no investigation, including IPR searches, has been carried out by ETSI. No guarantee can be given as to the existence of other IPRs not referenced in ETSI SR 000 314 (or the updates on the ETSI Web server) which are, or may be, or may become, essential to the present document.

---

## Foreword

This European Standard (Telecommunications series) has been produced by ETSI Technical Committee Transmission and Multiplexing (TM).

National transposition dates	
Date of adoption of this EN:	24 November 2000
Date of latest announcement of this EN (doa):	28 February 2001
Date of latest publication of new National Standard or endorsement of this EN (dop/e):	31 August 2001
Date of withdrawal of any conflicting National Standard (dow):	31 August 2001

---

# 1 Scope

The present document deals with spurious emissions at antenna port of Digital Fixed Radio Systems as defined by Radio Regulation Article 1 [15], ITU-R Recommendation SM.329-7 [1], ITU-R Recommendation F.1191-1 [2] and CEPT/ERC Recommendation 74-01 [3].

Moreover it covers immunity characteristics at receiver's antenna port.

Scope of the present document is to define specific limits at antenna port of spurious emissions and receiver immunity for suitable inter-working of Digital Fixed Radio Systems (i.e. Point-to-Point and Point-to-Multipoint systems) in the same or in different frequency band whenever allocated to Fixed Service in the range 9 kHz to 300 GHz.

However systems with fundamental emission below 30 MHz are not considered relevant for Digital Fixed Radio Systems and are outside the scope of the present document.

Spurious emissions levels and immunity performance at antenna port are also required to fulfil the EEC directive 89/336 [14] on EMC.

The present document complements CEPT/ERC Recommendation 74-01 [3] which gives Spurious Emissions limits with particular regards to "inter Services" operations, while WG TM4 assumed that in some case more protection is required for compatibility among fixed radio systems deployed in the same geographical area.

Additional considerations and background for producing the present document are:

- Radio Regulations definition of spurious emissions (RR Article 1 N°139 [15]) is aged and give concept and applicability which do not clearly fit to digital systems;
- ITU-R Recommendation SM.329-7 [1] includes emissions with digital modulation but allows options for the definition of the frequency boundary between out of band and spurious emissions and two different Category of level limits applicable to the Fixed Service;
- ITU-R Recommendation F.1191-1 [2] and CEPT/ERC Recommendation 74-01 [3] define the application of Radio Regulations concepts of Out of band, Unwanted and Spurious emissions to fixed Digital Radio Systems, clarify the applicability for the boundary between Out of band and Spurious emissions but maintain the same possible limit options provided by ITU-R Recommendation SM.329-7 [1];
- STC-RES09 has produced many ETSs covering EMC of radio equipment for mobile applications, which include emissions (or radiation) and immunity at antenna port; STC-RES09 also produced EN 301 489-1 [10] and EN 301 489-4 [11] covering EMC for fixed Radio links, which exclude, by mutual agreement with WG-TM4, spurious emissions and immunity at antenna port, which have to be defined by the product standards in order to cover all the technical parameters for conformance to the EMC Directive 89/336;
- considering the large number of TM4 deliverables it is convenient to maintain a single EN covering these parameters instead of replicating them on each single product standard, avoiding possible deviation from what required by other CEPT and ITU-R normative;
- limits of spurious emissions shall be fixed in view of inter-working compatibility among various Fixed Radio Systems in same or different band exploited in the same area;
- the measurement of the required limits should also be feasible in a suitable and cost effective Conformance test (informative annex B gives also information in this field);
- it is advisable that Fixed Radio Systems receivers provide a minimum level of immunity at antenna port towards possible interference at any frequency band of practical interest;
- a suitable and easy to perform criterion for Fixed Radio Systems receivers immunity at antenna port may be considered the application of a CW interference.

The present document will cover the limits of spurious emissions for already published ETSI deliverables for Fixed Radio Systems, for the time needed to produce suitable revision, in the following cases:

- the ETSI deliverable does not cover the external spurious emissions and/or receiver immunity items;
- the ETSI deliverable contains less demanding limits;
- the ETSI deliverable contains preliminary limits and/or undefined reference bandwidth.

Some ETSI deliverables for Fixed Radio Systems, sometimes, provide limits for both "external" and "internal" spurious emissions and the latter are outside the scope of the present document. Moreover the limits for emissions given in the present document do not prevent more stringent requirement given in those deliverables for intra-system purpose (i.e. local Transmitter to Receiver interference usually referred as "internal").

In order to fix the suitable limits, in informative annex B, spurious emissions are analysed from the point of view of a suitable test method for conformance testing.

---

## 2 References

The following documents contain provisions which, through reference in this text, constitute provisions of the present document.

- References are either specific (identified by date of publication, edition number, version number, etc.) or non-specific.
- For a specific reference, subsequent revisions do not apply.
- For a non-specific reference, the latest version applies.
- A non-specific reference to an ETS shall also be taken to refer to later versions published as an EN with the same number.

- [1] ITU-R Recommendation SM.329-7 (1997): "Spurious Emissions".
- [2] ITU-R Recommendation F.1191-1 (1997): "Bandwidths and unwanted emissions of digital radio-relay systems".
- [3] CEPT/ERC Recommendation 74-01 (1998): "Spurious emissions".
- [4] ETSI EN 301 126-1: "Fixed Radio Systems; Conformance testing; Part 1: Point-to-Point equipment - Definitions, general requirements and test procedures".
- [5] ETSI EN 301 126-2-1: "Fixed Radio Systems; Conformance testing; Part 2-1: Point-to-Multipoint equipment; Definitions and general requirements".
- [6] ETSI EN 301 126-2-2: "Fixed Radio Systems; Conformance testing; Part 2-2: Point-to-Multipoint equipment; Test procedures for FDMA systems".
- [7] ETSI EN 301 126-2-3: "Fixed Radio Systems; Conformance testing; Part 2-3: Point-to-Multipoint equipment; Test procedures for TDMA systems".
- [8] ETSI EN 301 126-2-4: "Fixed Radio Systems; Conformance testing; Part 2-4: Point-to-Multipoint equipment; Test procedures for FH-CDMA systems".
- [9] ETSI EN 301 126-2-5: "Fixed Radio Systems; Conformance testing; Part 2-5: Point-to-Multipoint equipment; Test procedures for DS-SS-SSMA systems".
- [10] ETSI EN 301 489-1: "Electromagnetic compatibility and Radio spectrum Matters (ERM); ElectroMagnetic Compatibility (EMC) standard for radio equipment and services; Part 1: Common technical requirements".
- [11] ETSI EN 301 489-4: "Electromagnetic compatibility and Radio spectrum Matters (ERM); ElectroMagnetic Compatibility (EMC) standard for radio equipment and services; Part 4: Specific conditions for fixed radio links and ancillary equipment and services".

- [12] ETSI TR 101 036-1: "Fixed Radio Systems; Point-to-point equipment; Generic wordings for standards on digital radio systems characteristics; Part 1: General aspects and point-to-point equipment parameters".
- [13] ITU-R Recommendation F.746-4 (1999): "Radio-frequency channel arrangements for radio-relay systems".
- [14] Council Directive 89/336/EEC of 3 May 1989 on the approximation of the laws of the Member States relating to electromagnetic compatibility.
- [15] ITU-R: "Radio Regulations Article 1".

---

## 3 Definitions, symbols and abbreviations

### 3.1 Definitions

For the purposes of the present document, the following terms and definitions apply.

**evaluation bandwidth:** bandwidth where the spurious emission limits are measured (e.g. the spectrum analyser resolution bandwidth) for further normalization/integration to the Reference bandwidth.

**out of band emissions:** ITU-R Recommendation F.1191-1 [2] defines that any unwanted emission which falls at frequencies separated from the centre frequency of the emission by less than 250 % of the relevant channel separation, where the system is intended to be used, will generally be considered out of band emission. See also RR Article 1 [15] N°138 and ITU-R Recommendations SM.329-7 [1] and CEPT/ERC Recommendation 74-01 [3].

**receiver spurious emissions:** spurious sent backwards to the antenna port by a receiver; sometimes they are also referenced as "spurious radiations".

**reference bandwidth:** bandwidth where the spurious emission limits are defined, see ITU-R Recommendation SM.329-7 [1].

**spurious emissions:** ITU-R Recommendation F.1191-1 [2] defines that any unwanted emission which falls at frequencies separated from the centre frequency of the emission by 250 % or more of the relevant channel separation, where the system is intended to be used, will generally be considered spurious emission. See also RR Article 1 [15] N°139 and ITU-R Recommendations SM.329-7 [1] and CEPT/ERC Recommendation 74-01 [3].

**unwanted emissions:** they are composed by Out of band and spurious emissions. See also RR Article 1 [15] N°140 and ITU-R Recommendations SM.329-7 [1] and F.1191-1 [2].

### 3.2 Symbols

For the purposes of the present document, the following symbols apply:

dBc	deciBels to carrier mean power
dBm	deciBels to milliwatt
GHz	GigaHertz
kHz	kilohertz
MHz	Megahertz

### 3.3 Abbreviations

For the purposes of the present document, the following abbreviations apply:

ATPC	Automatic Transmission Power Control
BER	Bit Error Rate
BWe	Evaluation BandWidth for spectral measurement (i.e. Spectrum analyser Resolution bandwidth)
BW <sub>r</sub>	Reference BandWidth
CS	Channel Separation

CW	Continuous Wave
DRRS	Digital Radio-Relay Systems
DUT	Device Under Test
Fc	cut-off Frequency
i.m.p.	Intermodulation products
MS	Master Station of a P-MP system
P-MP	Point-to-MultiPoint system
P-P	Point-to-Point system
QAM	Quadrature Amplitude Modulation
RF	Radio Frequency
RR	Radio Regulations
RS	Repeater Station (of a P-MP system)
RSL	Receiver Signal Level
Rx	Receiver
TS	Terminal Station (Remote out-station with subscriber interface) of a P-MP system
Tx	Transmitter
VSWR	Voltage Standing Wave Ratio

## 4 Transmitter spurious emissions at antenna port

According to ITU-R Recommendation SM.329-7 [1] and the application to fixed service provided by ITU-R Recommendation F.1191-1 [2], the external spurious emissions are defined as emissions at frequencies which are  $\pm 250\%$  of the relevant channel separation outside the nominal carrier frequency.

According ITU-R Recommendation F.1191-1 [2], the Channel Separation (CS) is taken as  $XS/2$  for alternated frequency channel arrangements and  $XS$  for co-channel and interleaved frequency channel arrangements as defined by ITU-R Recommendation F.746-4 [13].

The emission within  $\pm 250\%$  of the relevant channel separation includes only fundamental and out of band emissions which are outside the scope of the present document.

### 4.1 Limits

Unless more severe requirement were reported into a specific product ETSI deliverable, the spurious emissions at antenna port of Fixed Radio Systems of both transmitter and receiver shall be limited within the average power limits reported below.

For "noise-like" emissions, the limits are intended not to be exceeded in any elementary measuring bandwidth.

The limit values are defined at reference point C' shown in the general RF block diagram of figure 1.

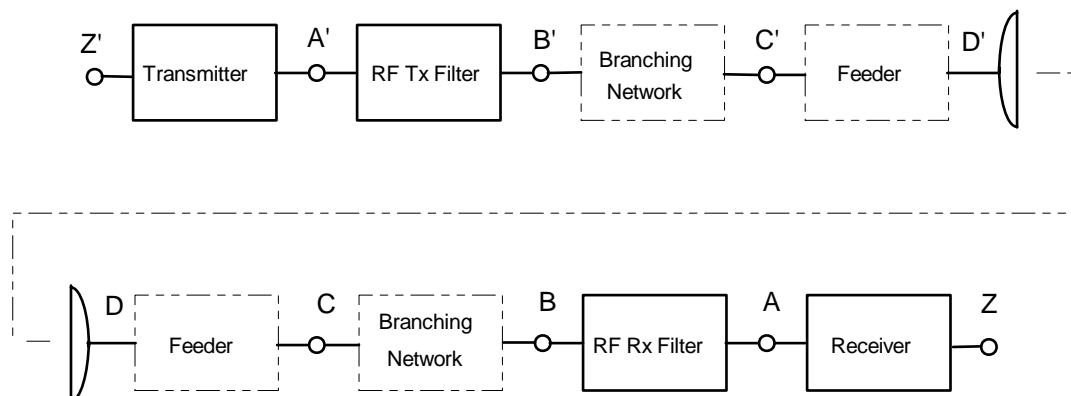

Figure 1: RF block diagram



### 4.1.1 Point-to-point equipments

The CEPT/ERC Recommendation 74-01 [3] shall apply.

For readers convenience, informative annex A gives the details for its application to practical systems.

### 4.1.2 Point-to-multipoint equipments with fundamental emission below 21,2 GHz

The CEPT/ERC Recommendation 74-01 [3] shall apply.

For readers convenience, informative annex A gives the details for its application to practical systems.

### 4.1.3 Point-to-multipoint equipments with fundamental emission above 21,2 GHz

The CEPT/ERC Recommendation 74-01 [3] shall apply for spurious emissions in the frequency range 9 kHz to 21,2 GHz and above 43,5 GHz.

For spurious emissions falling in the range 21,2 GHz to 43,5 GHz the tighter limits shown in figures 2 and 3 shall apply to both Central and Terminal Stations.

In this frequency range, where the -40 dBm limit shown in figures 2 and 3 apply, allowance is given for no more than 10 discrete (CW) spurious emissions which are permitted to exceed the limit up to -30 dBm.

In the same figures, for comparison, the less stringent limits from CEPT/ERC Recommendation 74-01 [3] are also shown.

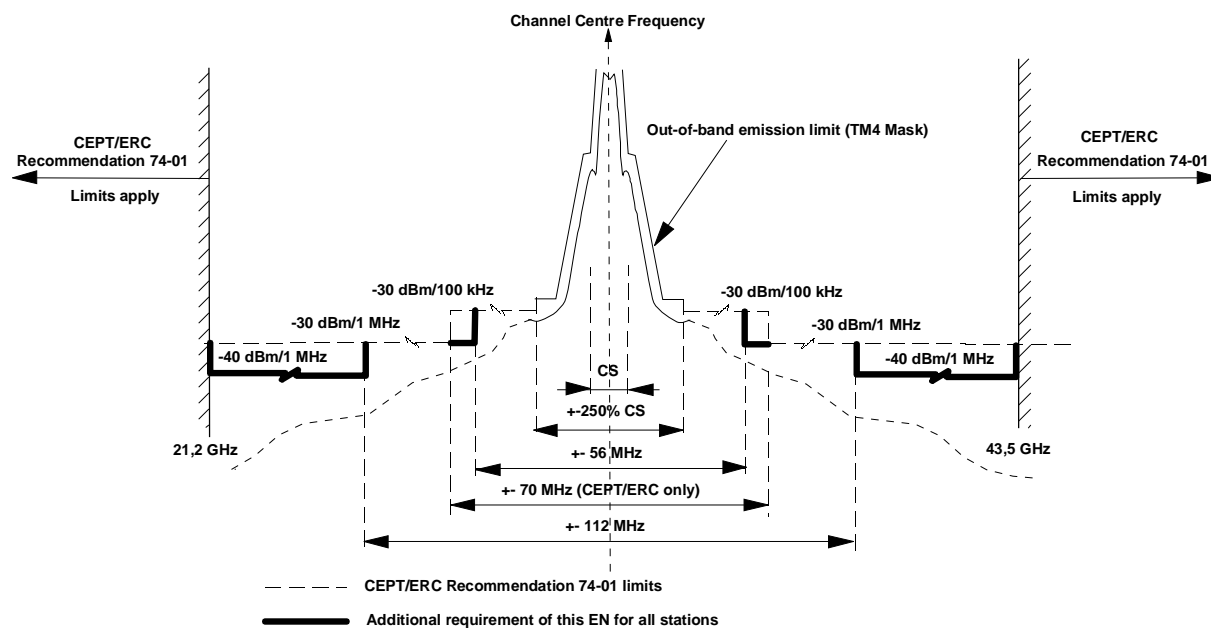

Figure 2: P-MP equipments for channel separation  $1 < CS \leq 10$  MHz

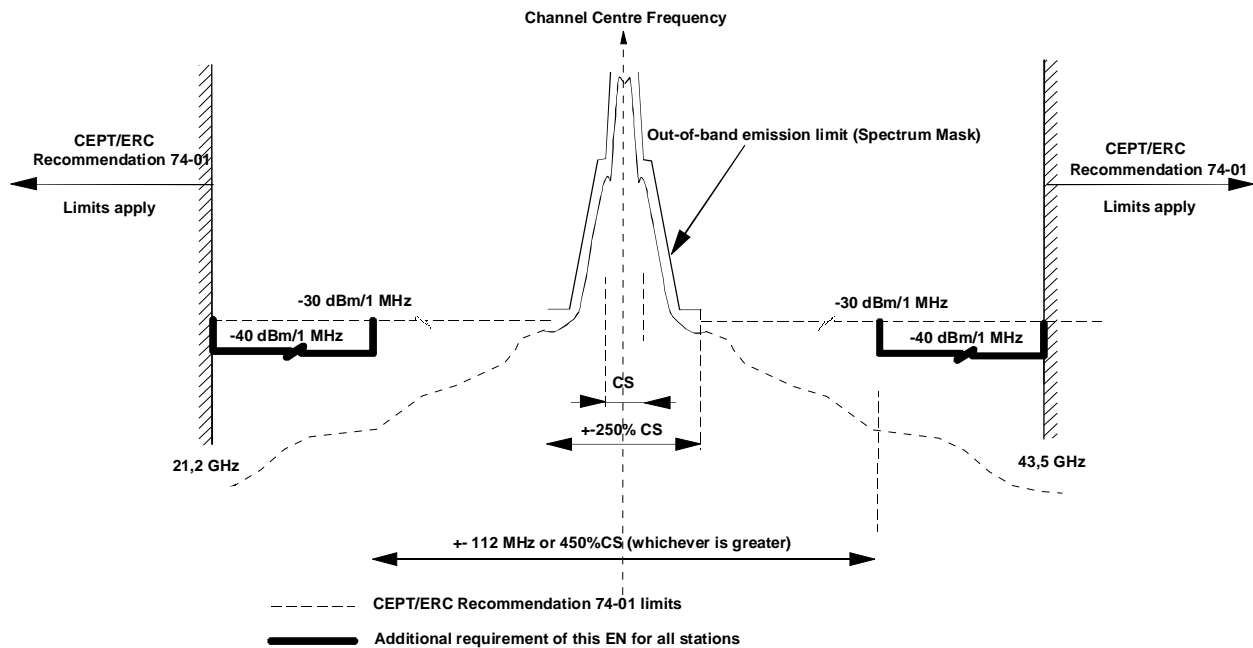

Figure 3: P-MP equipments for channel separation CS > 10 MHz

## 5 Receiver spurious emissions at the antenna port

Receiver spurious emissions are defined in the same frequency range of transmitters spurious emissions, without any exclusion band (such as the 250 % of the relevant channel separation) and are applicable at the reference point C of figure 1.

The CEPT/ERC Recommendation 74-01 [3] shall apply.

## 6 Spurious emissions test method

The measurement shall be referenced at the Tx/Rx common antenna port (reference points C-C' of figure 1).

According to the equipment physical construction, the test shall be carried on with the methodologies given in EN 301 126-1 [4] and EN 301 126-2-1 [5], EN 301 126-2-2 [6], EN 301 126-2-3 [7], EN 301 126-2-4 [8] and EN 301 126-2-5 [9]. The measurement shall be carried out with transmitters set to the higher level of continuous emission (see note) with the payloads inputs connected to a suitable test pattern, defined, for the equipment under consideration, in the applicable ETSI deliverable, if available, or by manufacturer declaration.

In order to provide easy and cost effective Conformance Test, the measurement may be carried out with wider BWe, provided that the results will be normalized to the required bandwidth with the methods reported in ITU-R Recommendation F.1191-1 [2] and CEPT/ERC Recommendation 74-01 [3].

NOTE: With ATPC disabled and set to the higher emission power.

## 7 Receivers immunity at antenna port

### 7.1 Limits

A suitable and easy to perform criterion is considered the application of a CW interference.

CW spurious response rejection ratio of a receiver is a measure of its ability to discriminate between the wanted signal at the nominal channel frequency of the receiver and an unwanted signal at any other frequency at which a response is obtained.

Unless more severe requirement were reported into a specific product ETSI deliverable, for a receiver operating at a RSL corresponding to the nominal  $10^{-6}$  BER threshold given by the relevant ETSI deliverable or in their vacancy by the Manufacturer declaration, the introduction of a CW interferer at a level of + 30 dB, with respect to the "wanted" signal shall not result in a BER greater than  $10^{-5}$ .

NOTE 1: This requirement is considered equivalent to a degradation of 1 dB of the  $10^{-6}$  BER threshold.

The requirement above shall be fulfilled at any frequency in the range given in table 1 (see note 2), excluding frequencies either side of the wanted frequency by:

- up to twice the foreseen co-polar channel spacing (for P-P systems);
- up to five times the foreseen co-polar channel spacing (for P-MP systems).

NOTE 2: When waveguide is used between reference points A and C of figure 1, which length is higher than twice the free space wavelength of cut-off frequency ( $F_c$ ), the lower limit of measurement will be increased to  $0,7 F_c$  and, when the length is higher than four times the same wavelength, to  $0,9 F_c$ .

**Table 1**

Fundamental receiver frequency range	CW Spurious Response frequency range	
	Lower frequency	Upper frequency (the test should include the entire harmonic band and not be truncated at the precise upper frequency limit stated)
9 kHz to 100 MHz	9 kHz	1 GHz
100 MHz to 300 MHz	9 kHz	10th harmonic
300 MHz to 600 MHz	30 MHz	3 GHz
300 MHz to 5,2 GHz	30 MHz	5th harmonic
5,2 GHz to 13 GHz	30 MHz	26 GHz
13 GHz to 150 GHz	30 MHz	2nd harmonic
150 GHz to 300 GHz	30 MHz	300 GHz

The above kind of immunity do not exclude other more demanding requirement of a specific product (pr)ETSI deliverable, if any.

### 7.2 Receiver immunity test method

The measurement shall be referenced at the Tx/Rx common antenna port (reference points C-C' of figure 1).

According to the equipment physical construction, the test shall be carried on with the methodologies given in EN 301 126-1 [4] and EN 301 126-2-1 [5], EN 301 126-2-2 [6], EN 301 126-2-3 [7], EN 301 126-2-4 [8] and EN 301 126-2-5 [9].

## Annex A (informative): Application of CEPT/ERC Recommendation 74-01

The limits of the spurious emissions required by the present document are reported in CEPT/ERC Recommendation 74-01 [3]; however, for reader convenience, relevant limits of this recommendation is reported below in relation to those required by the present document.

### A.1 Frequency range of applicability

According to ITU-R Recommendation SM.329-7 [1] and the application to fixed service provided by ITU-R Recommendation F.1191-1 [2], CEPT/ERC Recommendation 74-01 [3] defines spurious emissions as any emission at frequencies which are outside the nominal carrier frequency by more than  $\pm 250\%$  of the relevant channel separation.

The CEPT/ERC Recommendation 74-01 [3] requires that the limits on spurious emissions for radio equipments are considered here to be applicable to the range 9 kHz to 300 GHz. However, for practical measurement purpose only, the frequency range of spurious emissions may be restricted. As guidance for practical purposes, the measurement parameters reported in table A.1 are normally recommended by CEPT/ERC Recommendation 74-01 [3].

**Table A.1**

Fundamental frequency range	Spurious frequency range	
	Lower frequency	Upper frequency (The test should include the entire harmonic band and not be truncated at the precise upper frequency limit stated)
9 kHz to 100 MHz	9 kHz	1 GHz
100 MHz to 300 MHz	9 kHz	10th harmonic
300 MHz to 600 MHz	30 MHz	3 GHz
300 MHz to 5,2 GHz	30 MHz	5th harmonic
5,2 GHz to 13 GHz	30 MHz	26 GHz
13 GHz to 150 GHz	30 MHz	2nd harmonic
150 GHz to 300 GHz	30 MHz	300 GHz

These parameters reflect the increasing difficulty in undertaking practicable tests, especially at frequencies approaching or beyond 110 GHz, taking into account such factors as availability and usability of suitable measurement equipment. In some circumstances, it may be necessary to extend the range of test frequencies in order to better facilitate protection of other services such as Radioastronomy. In any case, systems having an integral antenna incorporating a waveguide section, or with an antenna connection in such form, and of length equal to at least twice the cut-off wavelength, should not require spurious emissions measurement below 0,7 times the waveguide cut-off frequency.

For "noise-like" emissions, the limits are intended not to be exceeded in any elementary measuring bandwidth.

## A.2 Level limits

The CEPT/ERC Recommendation 74-01 [3] requires the limits reported in table A.2.

**Table A.2**

<b>LIMIT FOR FIXED SERVICE RADIO RELAY SYSTEMS</b>	
<b>Type of equipment</b>	<b>Limits mean power or, when applicable, average power during bursts duration in the reference bandwidth</b>
Fixed Service (all station except those below)	-50 dBm 9 kHz < $f$ < 21,2 GHz (note 1) -30 dBm 21,2 GHz < $f$ (see clause A.1) (note 1)
Fixed Service - Terminal station (out station with subscriber equipment interfaces) (note 2)	-40 dBm 9 kHz < $f$ < 21,2 GHz (note 1) -30 dBm 21,2 GHz < $f$ (see clause A.1) (note 1)
Fixed Service – Receivers	The same limits as for the transmitters above apply
<p>NOTE 1: For digital systems it is necessary to provide one or more steps of reference bandwidth to produce suitable transition area for the spectral density to manage the required limit because in some frequency bands and/or applications narrow band RF filters are not technically or economically feasible. Consequently, just outside the <math>\pm 250</math> % of the relevant Channel Separation, the limit of spurious emissions are defined with reference bandwidths as detailed by the generic figure A.1 and the related table A.3.</p> <p>NOTE 2: Point-to-Multipoint systems used in CEPT countries foresee three kind of stations:</p> <ul style="list-style-type: none"> <li>- MS Master (Central) Station (clearly identifiable in ITU-R Recommendation SM.329-7 [1]);</li> <li>- TS Terminal Station (also clearly identifiable in ITU-R Recommendation SM.329-7 [1]);</li> <li>- RS Repeater Station (which is not referred in ITU-R Recommendation SM.329-7 [1]).</li> </ul> <p>Repeater Stations of Point-to-multipoint systems will be considered as Terminal stations when they are intended for use only in Remote stations not co-located with any other Fixed radio equipment classified as Central station.</p>	

When burst transmission is used, the mean power of any spurious emissions is measured using power averaging over the burst duration.

## A.3 Reference bandwidths

The following reference bandwidths are recommended by the CEPT/ERC Recommendation 74-01 [3]:

- 1 kHz for spurious emissions falling between 9 and 150 kHz;
- 10 kHz for spurious emissions falling between 150 kHz and 30 MHz;
- 100 kHz for spurious emissions falling between 30 MHz and 1 GHz;
- 1 MHz for spurious emissions falling above 1 GHz.

However, because in some frequency bands and/or applications narrow band RF filters are not technically or economically feasible, it is necessary to provide one or more steps of reference bandwidth to produce suitable transition area for the spectral density to manage the required limit.

Consequently, just outside the  $\pm 250$  % of the relevant channel spacing, the limit of spurious emissions are defined within the reference bandwidths detailed in the following figure A.1 and table A.3 in a comprehensive form.

NOTE: The reference bandwidths in figure A.1 and table A.3 is not applicable to receiver spurious emissions.

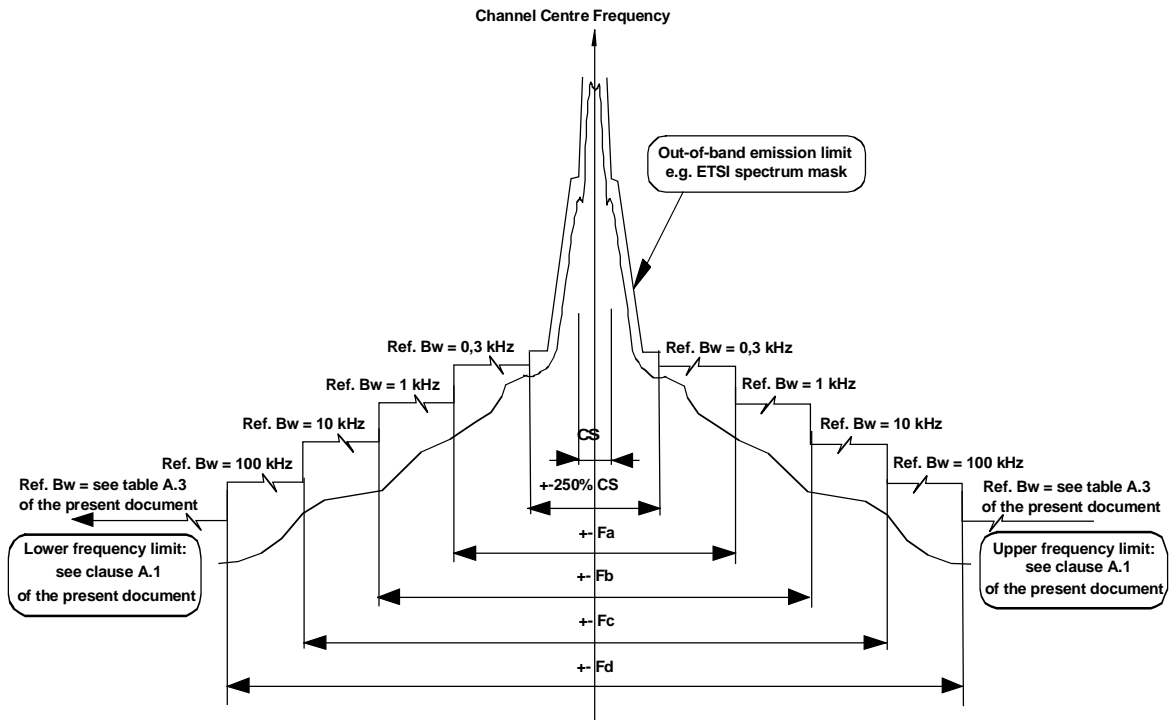

NOTE 1:  $\pm F_d$  frequency steps are not applicable if lower than 1 GHz.  
 NOTE 2:  $\pm F_c$  frequency steps are not applicable if lower than 30 MHz.  
 NOTE 3:  $\pm F_b$  frequency steps are not applicable if lower than 150 kHz.

Figure A.1: Generic spurious emission reference bandwidth limits mask (ref. to table A.3)

Table A.3

Fundamental Emission Frequency	Channel Spacing (CS) [MHz]	Typical Symbol Rate [-Mbaud/s]	BWr 0,3 kHz Fa [MHz]	BWr 1 kHz Fb [MHz]	BWr 10 kHz Fc [MHz]	BWr 100 kHz Fd [MHz]
Below 21,2 GHz	$0,01 \leq CS < 1$	$F_s \cong 0,06 \div 0,8$	-	-	14	28
(Terminal stations)	$1 \leq CS < 10$	$F_s \cong 0,6 \div 8$	-	-	28	70
	$CS \geq 10$	$F_s \sim > 6$	-	-	49 (note 1)	70 (note 1)
Below 21,2 GHz	$0,01 \leq CS < 1$	$F_s \cong 0,06 \div 0,8$	3,5	7	14	28
(Other stations)	$1 \leq CS < 10$	$F_s \cong 0,6 \div 8$	-	14 (note 1)	28	70
	$CS \geq 10$	$F_s \sim > 6$	-	-	49 (note 1)	70 (note 1)
Above 21,2 GHz	$1 \leq CS < 10$	$F_s \cong 0,6 \div 8$	-	-	-	70
(All stations) (note 2)	$CS \geq 10$	$F_s \sim > 6$	-	-	-	-

NOTE 1: Not applicable where the 250 % of CS exceed these values.  
 NOTE 2: The CEPT/ERC Recommendation 74-01 [3] do not make distinction for stations operating above 21,2 GHz, however for the purpose of the present document, the more stringent limits of subclause 4.1.3 apply to P-MP systems only.  
 NOTE 3: It is recognized that, depending on the characteristic of the emissions, the actual power density relative to the ETSI mask at the  $\pm 250\%$  boundary, when evaluated in the reference bandwidth of one or more steps of table A.3, may be lower than the spurious emission limit itself. In such cases these steps are not applicable and the first applicable spurious emission reference bandwidth step, which corresponds to a power density equal or lower than that evaluated with the ETSI mask in the same reference bandwidth, should be extended back to the  $\pm 250\%$  boundary (examples of this concept is shown in Informative annex B clause B2 (figures B.4, B.7, B.9 and B.11).

## A.4 Detailed application of the reference bandwidths reported in table A.3

The above generic figures are detailed for the different ranges of transmitter fundamental emissions as follows.

### A.4.1 P-P and P-MP systems with fundamental emissions from 30 MHz to 1 GHz

a) BWr is taken equal to 0,3 kHz for:

- $0,01 \leq CS < 1$  MHz in the range from  $\pm 250$  % of CS to  $\pm 3,5$  MHz.

NOTE 1: Not applicable to TS and RS remote out-stations for which the -40 dBm limit apply.

b) BWr is taken equal to 1 kHz for:

- $0,01 \leq CS < 1$  MHz in the range from  $\pm 3,5$  MHz to  $\pm 7$  MHz; and for
- $1 \text{ MHz} \leq CS < 5,6$  MHz in the range from  $\pm 250$  % of channel spacing to  $\pm 14$  MHz.

NOTE 2: Not applicable to TS and RS remote out-stations for which the -40 dBm limit apply.

c) BWr is taken equal to 10 kHz for:

- terminal stations, for which the -40 dBm limit apply, for:
  - $0,01 \leq CS < 1$  MHz in the range from  $\pm 250$  % of CS to  $\pm 14$  MHz; for
  - $1 \text{ MHz} \leq CS < 10$  MHz in the range from  $\pm 250$  % of CS to  $\pm 28$  MHz; and for
  - $10 \text{ MHz} \leq CS < 19,6$  MHz in the range from  $\pm 250$  % of CS to  $\pm 49$  MHz.
- other stations for:
  - $0,01 \leq CS < 1$  MHz in the range from 7 MHz to  $\pm 14$  MHz; for
  - $1 \text{ MHz} \leq CS < 5,6$  MHz in the range from  $\pm 14$  MHz to  $\pm 28$  MHz; for
  - $5,6 \text{ MHz} \leq CS < 10$  MHz in the range from  $\pm 250$  % of CS to  $\pm 28$  MHz; and for
  - $10 \text{ MHz} \leq CS < 19,6$  MHz in the range from  $\pm 250$  % of CS to  $\pm 49$  MHz.

### A.4.2 P-P and P-MP systems with fundamental emissions from 1 GHz to 21,2 GHz

a) BWr shall be taken equal to 0,3 kHz for:

- $0,01 \leq CS < 1$  MHz in the range from  $\pm 250$  % of CS to  $\pm 3,5$  MHz.

NOTE 1: Not applicable to TS and RS remote out-stations for which the -40 dBm limit apply.

b) BWr shall be taken equal to 1 kHz for:

- $0,01 \leq CS < 1$  MHz in the range from  $\pm 3,5$  MHz to  $\pm 7$  MHz; and for
- $1 \text{ MHz} \leq CS < 5,6$  MHz in the range from  $\pm 250$  % of channel spacing to  $\pm 14$  MHz.

NOTE 2: Not applicable to TS and RS remote out-stations for which the -40 dBm limit apply.

c) BWr shall be taken equal to 10 kHz for:

- terminal stations for which the -40 dBm limit apply for:
  - $0,01 \leq CS < 1$  MHz in the range from  $\pm 250$  % of CS to  $\pm 14$  MHz; for
  - $1 \text{ MHz} \leq CS < 10$  MHz in the range from  $\pm 250$  % of CS to  $\pm 28$  MHz; and for
  - $10 \text{ MHz} \leq CS < 19,6$  MHz in the range from  $\pm 250$  % of CS to  $\pm 49$  MHz.
- other Stations for:
  - $0,01 \leq CS < 1$  MHz in the range from 7 MHz to  $\pm 14$  MHz; for
  - $1 \text{ MHz} \leq CS < 5,6$  MHz in the range from  $\pm 14$  MHz to  $\pm 28$  MHz; for
  - $5,6 \text{ MHz} \leq CS < 10$  MHz in the range from  $\pm 250$  % of CS to  $\pm 28$  MHz; and for
  - $10 \text{ MHz} \leq CS < 19,6$  MHz in the range from  $\pm 250$  % of CS to  $\pm 49$  MHz.

d) BWr shall be taken equal to 100 kHz for:

- $0,01 \leq CS < 1$  MHz in the range from  $\pm 14$  MHz to  $\pm 28$  MHz; for
- $1 \text{ MHz} \leq CS < 10$  MHz in the range from  $\pm 28$  MHz to  $\pm 70$  MHz; for
- $10 \text{ MHz} \leq CS < 19,6$  MHz in the range from  $\pm 49$  MHz to  $\pm 70$  MHz; and for
- $19,6 \text{ MHz} \leq CS < 28$  MHz in the range from  $\pm 250$  % of CS to  $\pm 70$  MHz.

### A.4.3 P-P systems with fundamental emissions above 21,2 GHz

BWr shall be taken equal to 100 kHz for:

- $1 \text{ MHz} \leq CS < 10$  MHz in the range from  $\pm 250$  % of CS to  $\pm 70$  MHz.

### A.4.4 P-MP systems with fundamental emissions above 21,2 GHz

For these systems the CEPT/ERC Recommendation is less stringent than the present document, therefore the reader is demanded to subclause 4.1.3.



## Annex B (informative): Measurement background

### B.1 Spectrum analyser capability

The generic set-up for emissions measurement is shown in figure B.1.

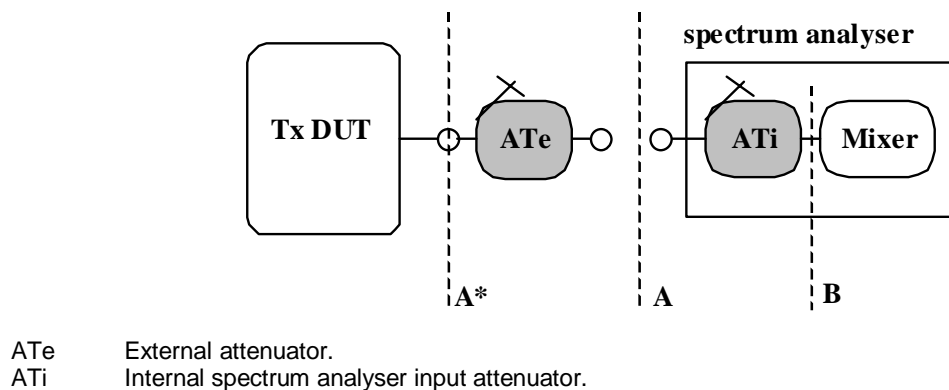

**Figure B.1: Spectrum measurement test schematic**

When digital modulation are concerned the available limits of measurement from a spectrum analyser are to be taken into account (see TR 101 036-1 [12]).

The following limitation for the spectrum analyser measurement apply depending on the characteristic of the instrument used:

- 1)  $B_{3rd}$ : Safe average input level at point B for distortion (at mixer input) (e.g. third order intermodulation reduction > 50 dBc);
- 2)  $B_{Max}$ : Max. input level at point B (e.g. with 10 dB att. for VSWR opt.);
- 3) minimum displayed absolute level of the equivalent noise floor at A\* point:
  - with > 50 dBc i.m.p. = Min displ. noise at A + (ATi + ATe);  
= Min displ. noise at A + (Pout -B<sub>3rd</sub>).
  - absolute minimum (with 10 dB Att. for VSWR):  
= Min displ noise at A + (Pout -B<sub>Max</sub>);  
= or (whichever is greater);  
= Min displ. noise at A + 10 dB.

### B.2 Application examples

The following figures shows applications of the limits provided by the present document and other above described limits to some common TM4 deliverables spectrum masks.

The relevant ETSI deliverable reports the spectrum mask(s) defined to limit the out of band portion of the emission (i.e. within the  $\pm 250\%$  of the relevant CS) together with the recommended reference bandwidth for conformance test purpose; however to visualize how the out of band portion of the spectral density fits to the spurious emissions limit at their boundary, the relative spectrum mask and the actual output power may be used to normalize the mask into a power density within the reference bandwidth where the first step of spurious emissions limit is defined.

NOTE: For discrete components of spurious emissions this normalization is not effective provided that their limit is independent from the reference bandwidth.

The output power of the systems (necessary to evaluate the absolute level of the signal spectral density and to set the values of the attenuators AT<sub>li</sub> and A<sub>Te</sub>) has been taken as a typical achievable level in the relevant frequency band.

In the following figures two noise floor limits of spectrum analyser are shown and marked with the explanatory notes:

- (1): typical noise floor with 3rd order i.m.products > 50 dB;
- (2): typical noise floor with maximum input level (highest dynamic range).

The noise floor limit with > 50 dB i.m.p. has been shown for example only, however in practice it may be necessary for near carrier measurement of QAM systems only, not to impair the precision. other have to be evaluated case by case (see TR 101 036-1 [12] for background in this field).

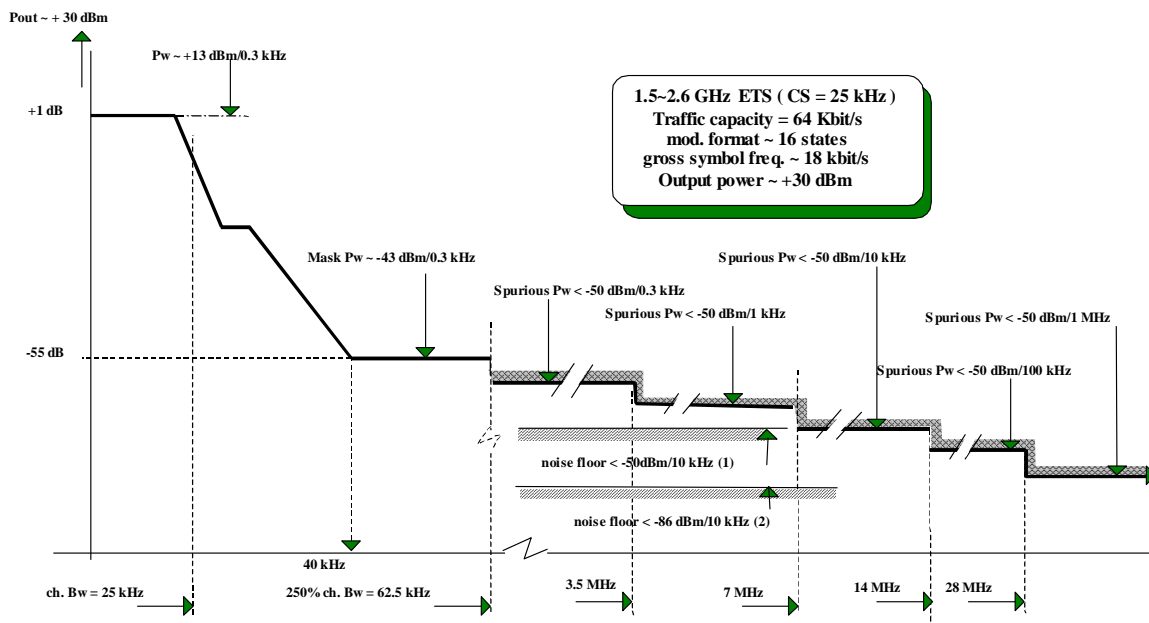

Figure B.2

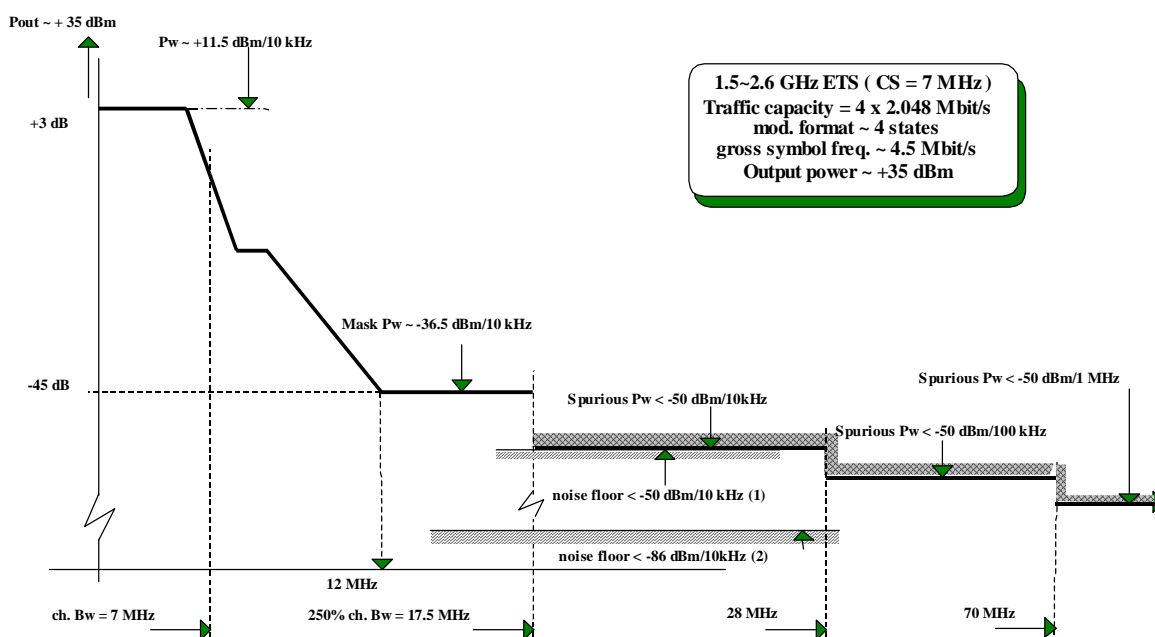
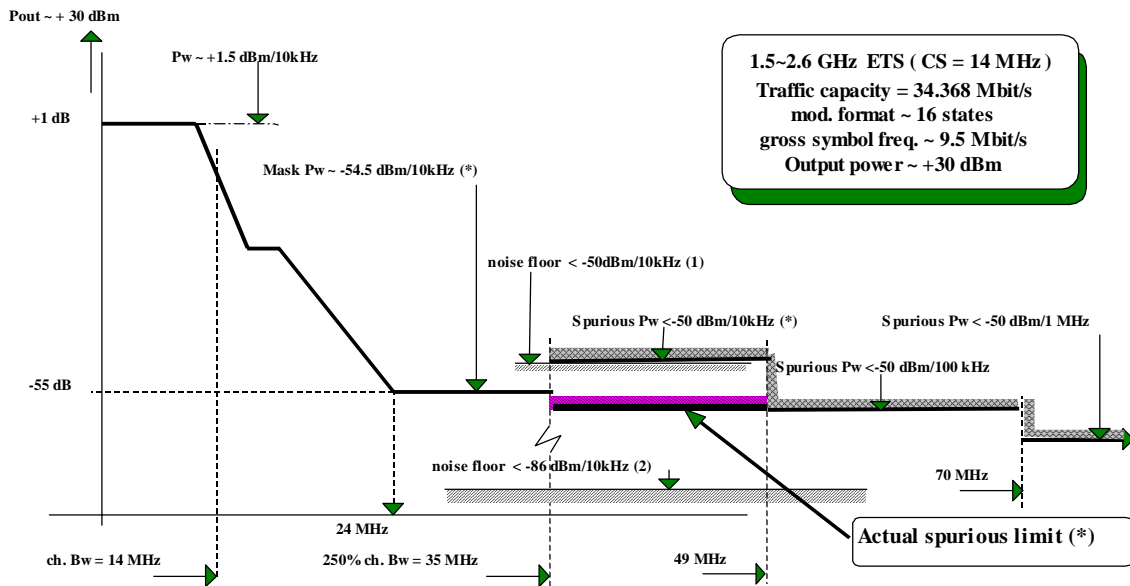
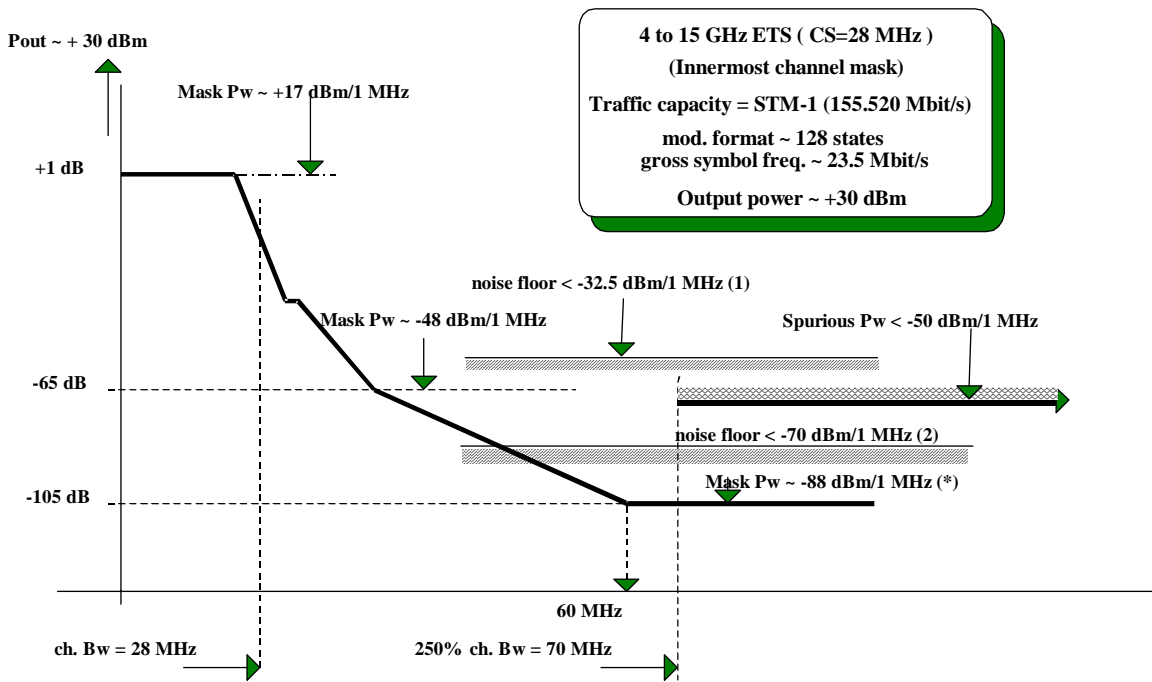

Figure B.3



(\*): Example of reference bandwidth step not applicable (see note in table A.3).

Figure B.4



(\*) Above 70 MHz intra system compatibility only

Figure B.5

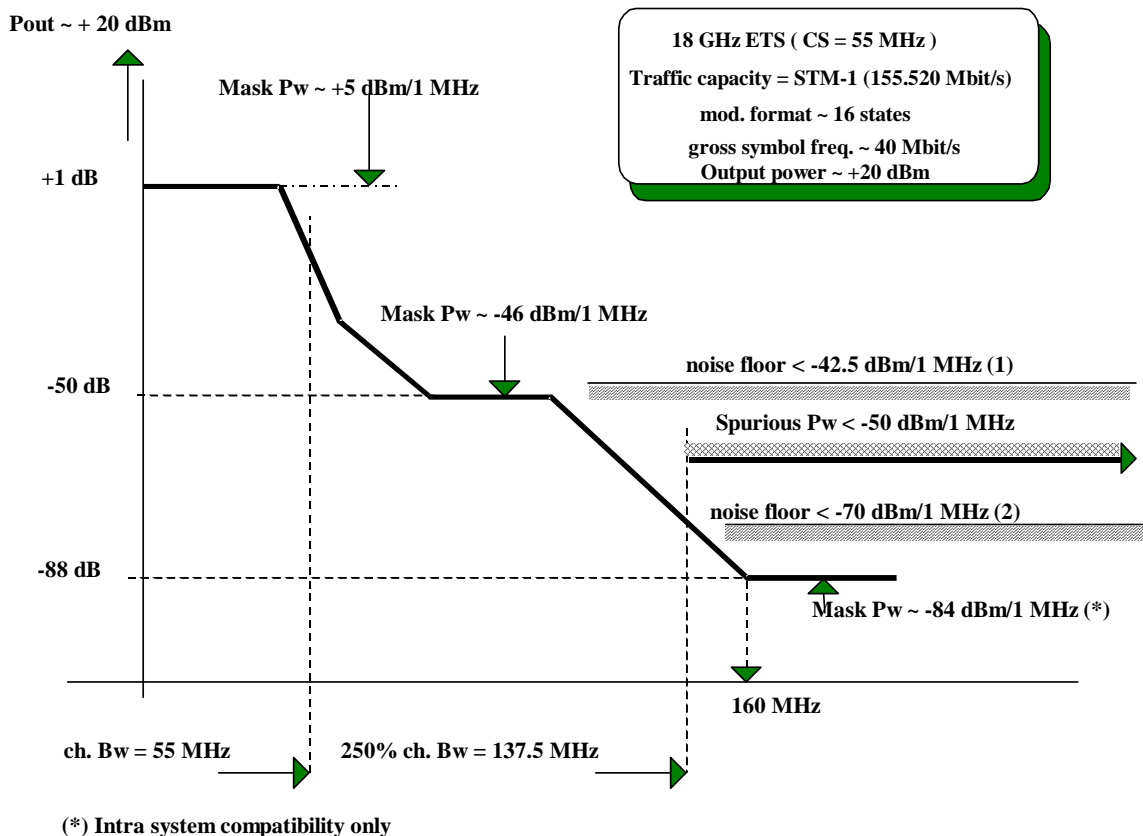
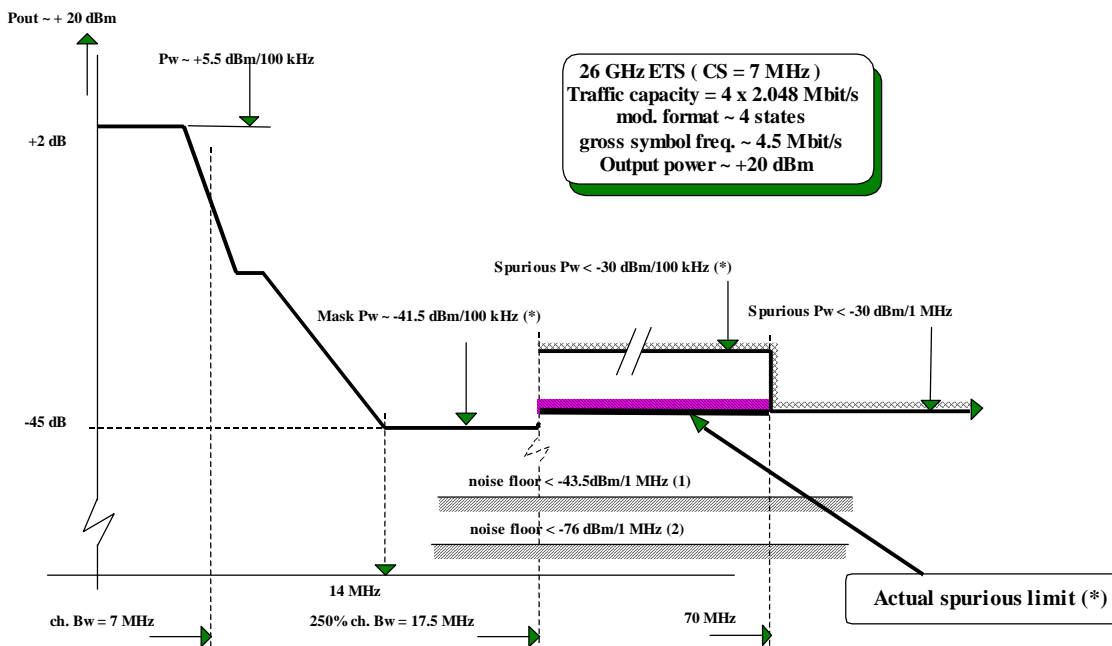

Figure B.6



(\*): Example of reference bandwidth step not applicable (see note in table A.3).

Figure B.7

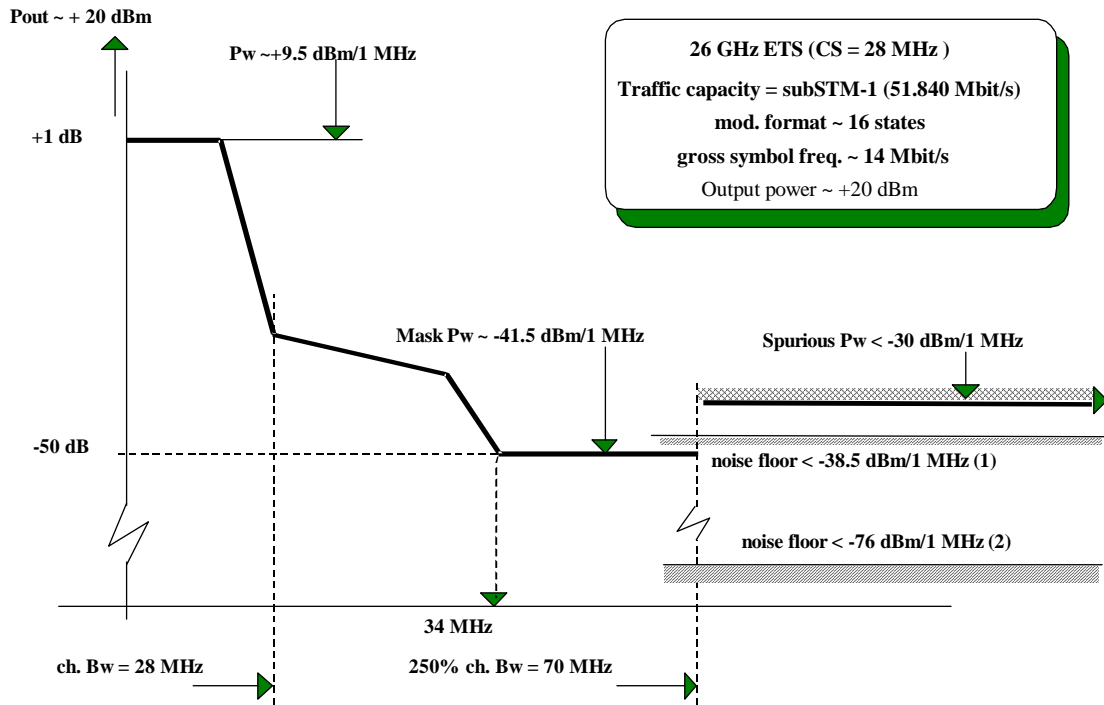
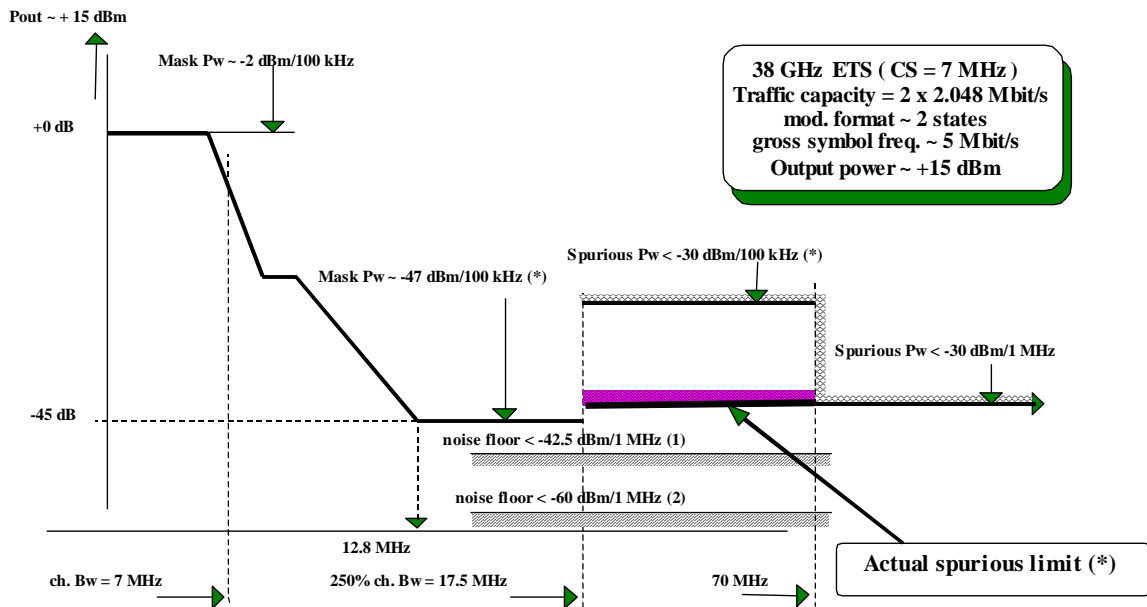

Figure B.8



(\*): Example of reference bandwidth step not applicable (see note in table A.3).

Figure B.9

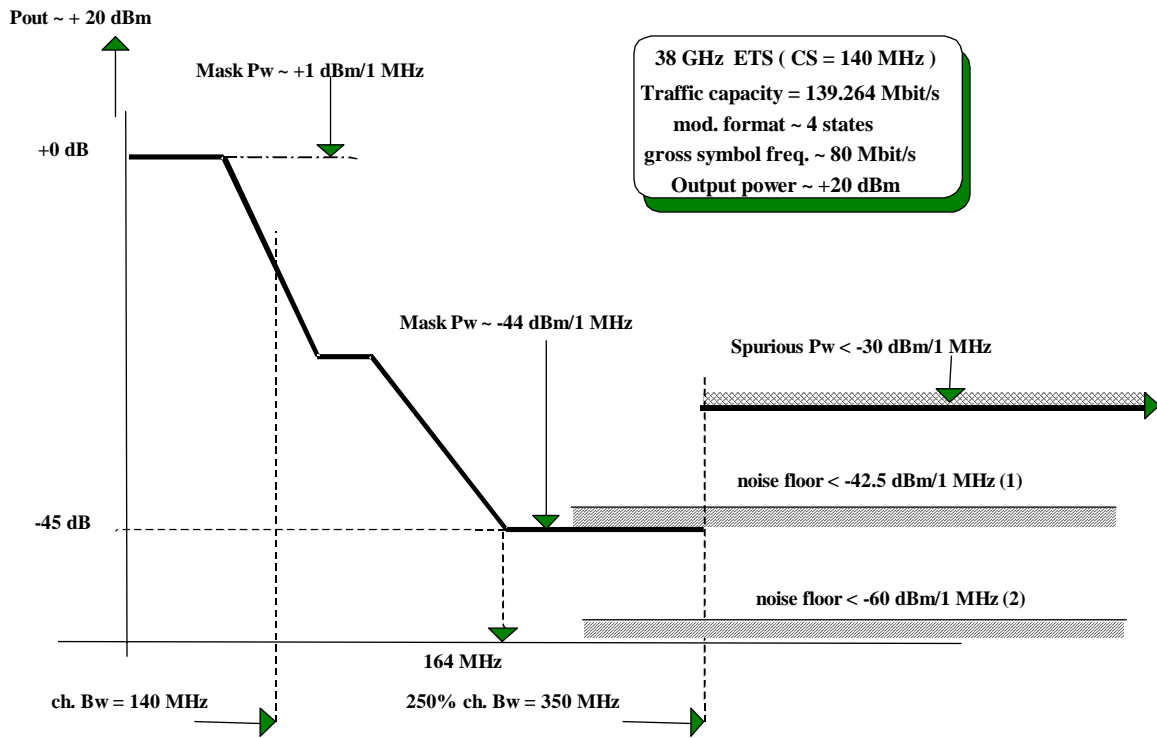
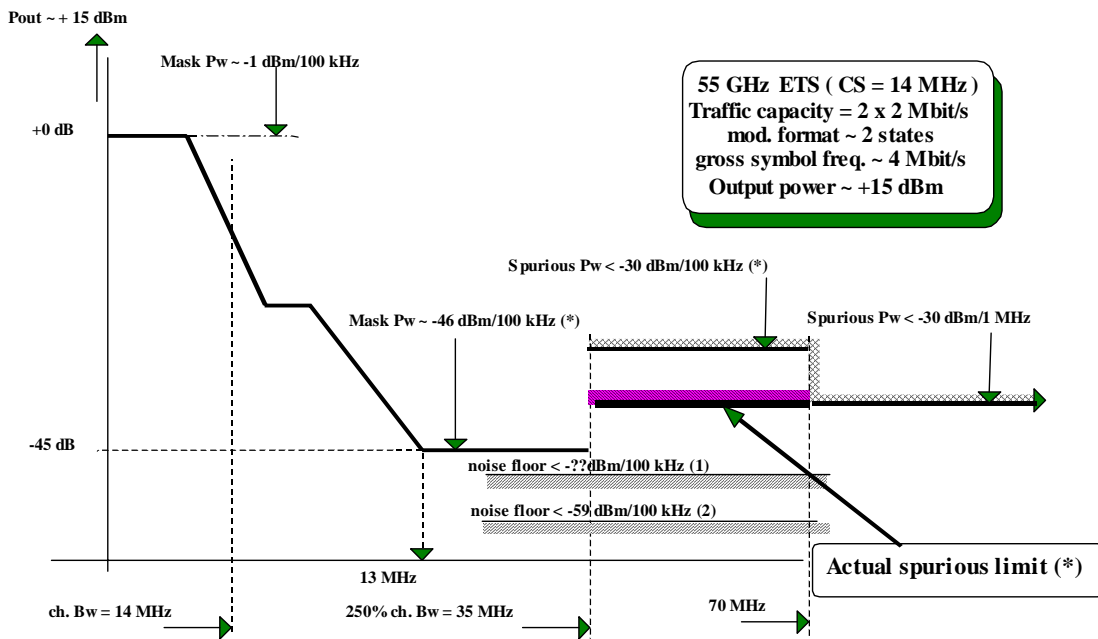

Figure B.10



(\*): Example of reference bandwidth step not applicable (see note in table A.3).

Figure B.11

---

## History

<b>Document history</b>		
V1.1.1	October 1999	Public Enquiry PE 9963: 1999-10-13 to 2000-02-11
V1.1.1	September 2000	Vote V 20001124: 2000-09-25 to 2000-11-24
V1.1.1	December 2000	Publication