

Draft **ETSI EN 301 387** V1.2.1 (2000-10)

---

*European Standard (Telecommunications series)*

**Fixed Radio Systems;  
Point-to-point equipment;  
Plesiochronous Digital Hierarchy (PDH);  
Low and medium capacity digital radio systems  
operating in the frequency band 48,5 GHz to 50,2 GHz**

---



---

**Reference**

REN/TM-04111-16

---

**Keywords**

DRRS, point-to-point, PDH, transmission, radio

**ETSI**

---

650 Route des Lucioles  
F-06921 Sophia Antipolis Cedex - FRANCE

Tel.: +33 4 92 94 42 00 Fax: +33 4 93 65 47 16

Siret N° 348 623 562 00017 - NAF 742 C  
Association à but non lucratif enregistrée à la  
Sous-Préfecture de Grasse (06) N° 7803/88

---

**Important notice**

Individual copies of the present document can be downloaded from:

<http://www.etsi.org>

The present document may be made available in more than one electronic version or in print. In any case of existing or perceived difference in contents between such versions, the reference version is the Portable Document Format (PDF). In case of dispute, the reference shall be the printing on ETSI printers of the PDF version kept on a specific network drive within ETSI Secretariat.

Users of the present document should be aware that the document may be subject to revision or change of status. Information on the current status of this and other ETSI documents is available at <http://www.etsi.org/tb/status/>

If you find errors in the present document, send your comment to:  
editor@etsi.fr

---

**Copyright Notification**

No part may be reproduced except as authorized by written permission.  
The copyright and the foregoing restriction extend to reproduction in all media.

© European Telecommunications Standards Institute 2000.  
All rights reserved.

# Contents

Intellectual Property Rights .....	4
Foreword.....	4
1 Scope .....	5
2 References .....	5
3 Symbols and abbreviations.....	6
3.1 Symbols.....	6
3.2 Abbreviations .....	6
4 General characteristics .....	7
4.1 Frequency bands and channel arrangements .....	7
4.1.1 Frequency band in the range 48,5 GHz to 50,2 GHz .....	7
4.1.2 Co-polar channel spacing for like carriers .....	7
4.1.3 Transmit/receive duplex frequency separation .....	7
4.2 Performance prediction and objectives.....	7
4.3 Compatibility requirements between systems .....	7
4.4 Types of installation .....	7
4.4.1 Environmental conditions .....	8
4.4.1.1 Equipment within weather protected locations .....	8
4.4.1.2 Equipment for non-weather protected locations.....	8
4.4.2 ElectroMagnetic Compatibility.....	8
4.5 Block diagram .....	8
4.6 General characteristics .....	8
4.7 Telecommunications Management Network (TMN) interface.....	9
4.8 Branching/feeder/antenna requirements .....	9
4.9 Mechanical requirements .....	9
4.10 Power supply .....	9
5 Parameters for digital systems.....	9
5.1 Transmission capacity .....	9
5.2 Applications .....	9
5.3 Baseband parameters .....	9
5.3.1 Plesiochronous interfaces .....	9
5.4 Transmitter characteristics.....	10
5.4.1 Transmitter power range .....	10
5.4.2 Transmitter output power tolerance .....	10
5.4.3 RF spectrum mask .....	10
5.4.3.1 Spectrum density mask .....	10
5.4.3.2 Discrete CW lines exceeding the spectrum mask limit .....	11
5.4.4 Spurious emissions .....	12
5.4.5 RF tolerance.....	12
5.5 Receiver characteristics .....	12
5.5.1 Input level range .....	12
5.5.2 Spurious emissions .....	12
5.6 System performance .....	13
5.6.1 BER performance .....	13
5.6.2 Equipment background BER .....	13
5.6.3 Interference sensitivity.....	13
5.6.4 Distortion sensitivity.....	14
Bibliography .....	15
History .....	16

---

## Intellectual Property Rights

IPRs essential or potentially essential to the present document may have been declared to ETSI. The information pertaining to these essential IPRs, if any, is publicly available for **ETSI members and non-members**, and can be found in ETSI SR 000 314: "*Intellectual Property Rights (IPRs); Essential, or potentially Essential, IPRs notified to ETSI in respect of ETSI standards*", which is available from the ETSI Secretariat. Latest updates are available on the ETSI Web server (<http://www.etsi.org/ipr>).

Pursuant to the ETSI IPR Policy, no investigation, including IPR searches, has been carried out by ETSI. No guarantee can be given as to the existence of other IPRs not referenced in ETSI SR 000 314 (or the updates on the ETSI Web server) which are, or may be, or may become, essential to the present document.

---

## Foreword

This European Standard (Telecommunications series) has been produced by ETSI Technical Committee Transmission and Multiplexing (TM), and is now submitted for the ETSI standards One-step Approval Procedure.

The present document is a revision of EN 301 387 (V1.1.2), in which the clauses 3.2 and 5.4.3 have been modified to take in account the additional requirements for spectral lines present in the spectrum. The OAP only applies to these clauses.

The former title of the present document was "Transmission and Multiplexing (TM); Digital Radio Relay Systems (DRRS); Plesiochronous Digital Hierarchy (PDH); Low and medium capacity DRRS operating in the frequency band 48,5 GHz to 50,2 GHz".

The present document specifies the minimum performance parameters for radio equipment operating in the frequency range 48,5 GHz to 50,2 GHz as specified in the scope. Other Standards cover radiocommunications equipment not listed in clause 1.

<b>Proposed national transposition dates</b>	
Date of latest announcement of this EN (doa):	3 months after ETSI publication
Date of latest publication of new National Standard or endorsement of this EN (dop/e):	6 months after doa
Date of withdrawal of any conflicting National Standard (dow):	6 months after doa

---

# 1 Scope

The present document covers the minimum performance requirements for terrestrial fixed services radiocommunications equipment, as given below, in the frequency band 48,5 GHz to 50,2 GHz.

The present document specifies the performance criteria for digital signals.

As the maximum transmissible rate in a given bandwidth depends on system spectral efficiency, different classes are defined:

- class 1: equipment based on a minimum 2-level modulation scheme (e.g. 2-FSK or equivalent);
- class 2: equipment based on a minimum 4-level modulation scheme (e.g. 4-FSK, 4-PSK, or equivalent).

Safety aspects are outside the scope of the present document.

---

# 2 References

The following documents contain provisions which, through reference in this text, constitute provisions of the present document.

- References are either specific (identified by date of publication, edition number, version number, etc.) or non-specific.
- For a specific reference, subsequent revisions do not apply.
- For a non-specific reference, the latest version applies.

- [1] ETSI ETS 300 019, Parts 1-1 and 1-2: "Equipment engineering (EE); Environmental conditions and environmental tests for telecommunications equipment; Part 1-1: Classification of environmental conditions; Storage; Part 1-2: Classification of environmental conditions; Transportation".
- [2] ETSI ETS 300 132, Parts 1 and 2: "Equipment engineering (EE); Power supply interface at the input to telecommunications equipment; Part 1: Operated by alternating current (ac) derived from direct current (dc) sources; Part 2: Operated by direct current (dc)".
- [3] ETSI EN 300 385: "Electromagnetic compatibility and Radio spectrum Matters (ERM); ElectroMagnetic Compatibility (EMC) standard for fixed radio links and ancillary equipment".
- [4] ITU-T Recommendation G.703 (1991): "Physical / electrical characteristics of hierarchical digital interfaces".
- [5] ITU-T Recommendation G.784 (1991): "Synchronous Digital Hierarchy (SDH) management".
- [6] CEPT/ERC/Recommendation 12-10 (1998): "Harmonised radio frequency arrangements for digital systems operating in the band 48,5 GHz - 50,2 GHz".
- [7] ITU-T Recommendation G.826: "Error performance parameters and objectives for international, constant bit rate digital paths at or above the primary rate".
- [8] ITU-R Recommendation F.1189-1: "Error performance objectives for constant bit rate digital paths at or above the primary rate carried by digital radio-relay systems which may form part or all of the national portion of a 27 500 km hypothetical reference path".
- [9] ETSI EN 300 833: "Fixed Radio Systems; Point to Point Antennas; Antennas for point-to-point fixed radio systems operating in the frequency band 3 GHz to 60 GHz".
- [10] ITU-T Recommendation G.773: "Protocol suites for Q-interfaces for management of transmission systems".

- [11] ITU-R Recommendation P.530-7: "Propagation data and prediction methods required for the design of terrestrial line-of-sight systems".
- [12] ITU-R Recommendation F.1191-1: "Bandwidths and unwanted emission of digital radio-relay systems".
- [13] CEPT/ERC Recommendation 74-01: "Spurious Emissions".

## 3 Symbols and abbreviations

### 3.1 Symbols

For the purposes of the present document, the following symbols apply:

dB	decibel
dBm	decibel relative to 1 milliwatt
GHz	Gigahertz
Mbit/s	Mega-bits per second
MHz	Megahertz
ppm	parts per million

### 3.2 Abbreviations

For the purposes of the present document, the following abbreviations apply:

BER	Bit Error Ratio
CW	Continuous Wave
CSmin	minimum practical Channel Separation (for a given radio-frequency channel arrangement)
DC	Direct Current
DRRS	Digital radio Relay Systems
FSK	Frequency-Shift Keying
N/A	Not Applicable
PSK	Phase-Shift Keying
RF	Radio Frequency
RSL	Receive Signal Level
S/I	Signal to Interference ratio
TMN	Telecommunications Management Network

## 4 General characteristics

### 4.1 Frequency bands and channel arrangements

#### 4.1.1 Frequency band in the range 48,5 GHz to 50,2 GHz

Channel Plan: The channel plan shall be in accordance with CEPT/ERC/Recommendation 12-10 [6] with a basic raster of 3,5 MHz.

#### 4.1.2 Co-polar channel spacing for like carriers

For systems operating on the same antenna, see clause 4.3 (a).

**Table 1: Co-polar Channel Spacing**

Minimum Bit Rate (Mbit/s)	2	2 x 2	4 x 2 or 8	8 x 2 or 2 x 8	16 x 2 or 34
Channel Spacing (MHz) Class 1 Equipments	7	14	28	N/A	N/A
Channel Spacing (MHz) Class 2 Equipments	3,5	3,5	7	14	28

#### 4.1.3 Transmit/receive duplex frequency separation

The transmitter receiver duplex frequency separation shall be 884 MHz in accordance with the CEPT harmonized radio frequency channel plan [6].

### 4.2 Performance prediction and objectives

NOTE: This clause is for reference only.

Systems considered in the present document should be designed in order to meet network performance requirements foreseen by ITU-T Recommendation G.826 [7] following the criteria defined in ITU-R Recommendation F.1189-1 [8] for the national portion of the digital connection.

The dominant fading mechanism is rain attenuation; performance prediction methods should be based on the latest issues of the ITU-R Recommendation P.530-7 [11], see clause 4.3.

### 4.3 Compatibility requirements between systems

- a) Systems should be required to operate on common hops using either separate antennas or the same antenna.
- b) There should be no requirement to operate transmitting equipment from one manufacturer with receiving equipment from another, or to multiplex different manufacturers equipment on the same antenna.

### 4.4 Types of installation

The equipment may comprise both radio-relay units in weather protected locations and outdoor units with the RF assemblies located close to the antenna in order to minimize feeder losses.

## 4.4.1 Environmental conditions

The equipment shall be required to meet either the environmental conditions set out in ETS 300 019 [1] which defines weather protected and non-weather protected locations, classes and test severities or one of the conditions listed in clause 4.4.1.2.

### 4.4.1.1 Equipment within weather protected locations

Equipment intended for operation within temperature controlled locations or partially temperature controlled locations shall meet the requirements of ETS 300 019 [1] subclasses 3.1 and 3.2 respectively.

Optionally the more stringent requirements of ETS 300 019 [1] subclasses 3.3 (non temperature controlled locations), 3.4 (sites with heat trap) and 3.5 (sheltered locations) may be used.

### 4.4.1.2 Equipment for non-weather protected locations

Equipment intended for operation within non-weather protected locations shall meet the requirements of ETS 300 019 [1], classes 4.1 or 4.1E.

Class 4.1 applies to many European countries and class 4.1E applies to all European countries.

## 4.4.2 ElectroMagnetic Compatibility

Equipment with capacities of 2 Mbit/s and above shall operate under the conditions specified in EN 300 385 [3].

## 4.5 Block diagram

The system diagram is shown in figure 1.

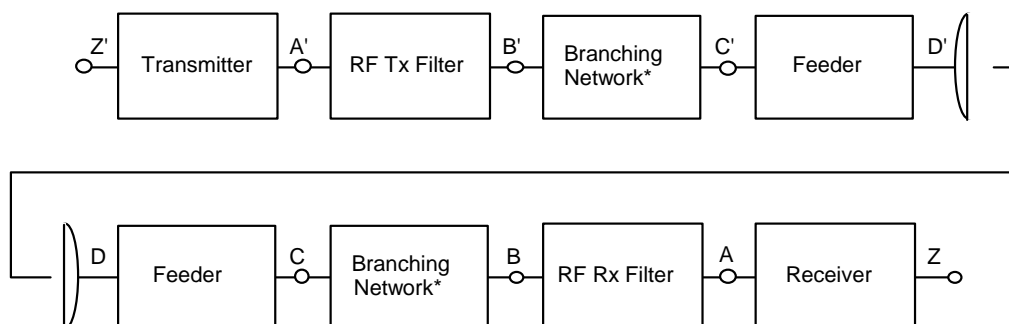

NOTE 1: For the purpose of defining the measurement points, the branching network does not include a hybrid.

NOTE 2: Points B and C, B' and C' may coincide.

**Figure 1: System diagram**

## 4.6 General characteristics

The following characteristics are desirable:

- tuning facilities;
- flexibility for repeated installation;
- wayside traffic facilities;
- transmitter identification;
- maintenance facilities;
- performance monitoring facilities.



## 4.7 Telecommunications Management Network (TMN) interface

A TMN interface required by a user should be in accordance with ITU-T Recommendation G.784 [5] and ITU-T Recommendation G.773 [10].

## 4.8 Branching/feeder/antenna requirements

- a) The minimum recommended antenna radiation pattern envelopes are given in EN 300 833 [9].
- b) Antenna flange/equipment feeder flange. When flanges are required IEC type UBR/PBR 320 should be used.

## 4.9 Mechanical requirements

The following parameters should be taken into account in the design of equipment incorporating an external unit:

- a) maximum weight of external unit;
- b) size of external unit for wind loading considerations;
- c) maximum weight of replaceable units;
- d) ease of access to replaceable units.

## 4.10 Power supply

The power supply interface shall be in accordance with the characteristics of one or more of the secondary voltages foreseen in ETS 300 132 [2].

NOTE: Some applications may require secondary voltages that are not covered by ETS 300 132 [2].

For DC systems, the positive pole of the voltage supply will be earthed at the source.

---

# 5 Parameters for digital systems

## 5.1 Transmission capacity

Payload bit rates considered in the present document are: 2 048 kbit/s, 2 x 2 048 kbit/s, 4 x 2 048 kbit/s, 8 448 kbit/s, 8 x 2 048 kbit/s, 2 x 8 448 kbit/s, 16 x 2 048 kbit/s and 34 386 kbit/s.

## 5.2 Applications

2 Mbit/s - 34 Mbit/s point-to-point local and regional networks, mobile base station connections, subscriber access links, (including transportable and off-shore use).

## 5.3 Baseband parameters

### 5.3.1 Plesiochronous interfaces

Plesiochronous interfaces at 2 Mbit/s, 8 Mbit/s and 34 Mbit/s shall comply with ITU-T Recommendation G.703 [4]. Parameters for service channels and wayside traffic are outside the scope of the present document.

## 5.4 Transmitter characteristics

### 5.4.1 Transmitter power range

The maximum output power shall be 1 Watt referred to point C' of the system diagram as shown in figure 1.

### 5.4.2 Transmitter output power tolerance

The output power tolerance shall be within:

±3 dB: for systems operating within non-weather protected locations.

±2 dB: for systems operating within weather protected locations.

### 5.4.3 RF spectrum mask

#### 5.4.3.1 Spectrum density mask

The equipment shall comply with the digital RF power spectrum mask given in figure 2 of the present document. The 0 dB reference level shown on the spectrum masks relates to the highest spectral density of the modulated spectrum, excluding residual carrier. This reference level shall not be higher than 3 dB with respect to the spectral density at centre frequency.

NOTE: Spectrum analyser settings for RF power spectrum measurements are given in table 2.

**Table 2**

<b>Bit rate (Mbit/s) Class 1 Equipments</b>	N/A	N/A	2	2 x 2	4 x 2 or 8
<b>Bit rate (Mbit/s) Class 2 Equipments</b>	2	2 x 2	4 x 2 or 8	8 x 2 or 2 x 8	16 x 2 or 34
<b>Channel spacing (MHz)</b>	3,5	3,5	7	14	28
<b>IF Bandwidth (kHz)</b>	30	30	30	30	100
<b>Total sweep width (MHz)</b>	20	20	50	100	200
<b>Video bandwidth (kHz)</b>	0,1	0,1	0,1	0,1	0,1
<b>Recommended scan time (s)</b>	Auto	Auto	Auto	Auto	Auto

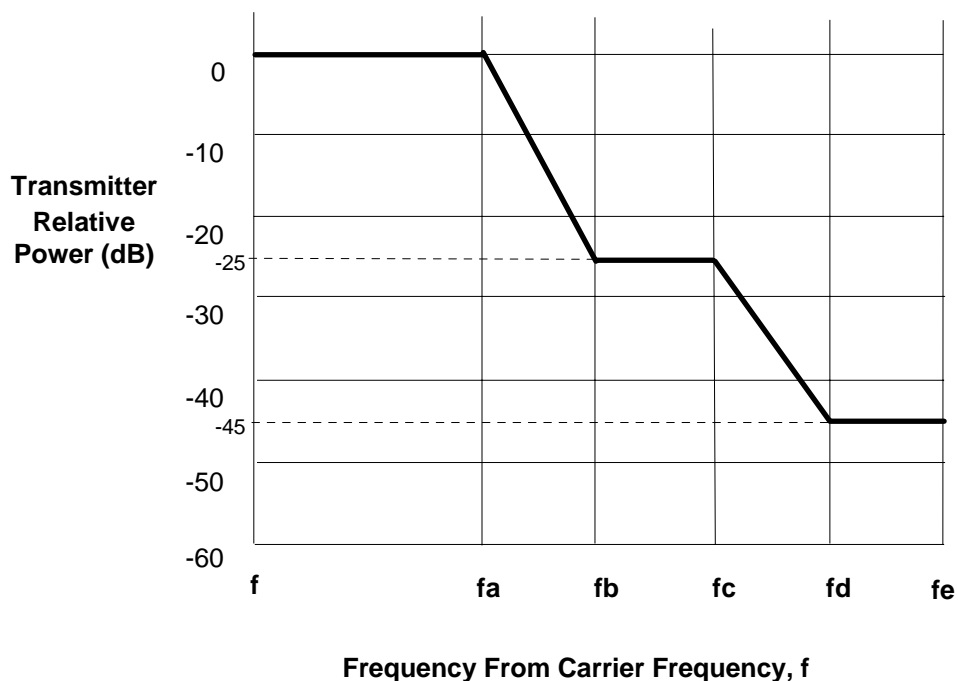

Channel Spacing	fa	fb	fc	fd	fe
3,5 MHz	1,3 MHz	2,6 MHz	3,2 MHz	5,2 MHz	8,75 MHz
7 MHz	2,6 MHz	5,2 MHz	6,4 MHz	10,4 MHz	17,5 MHz
14 MHz	5,2 MHz	10,4 MHz	12,8 MHz	20,8 MHz	35 MHz
28 MHz	10,5 MHz	19 MHz	24,5 MHz	35,5 MHz	70 MHz

**Figure 2: Limits of spectral power density as a function of channel spacing**

#### 5.4.3.2 Discrete CW lines exceeding the spectrum mask limit

In case some CW components exceed the spectrum mask, an additional allowance is given.

Those lines shall not:

- exceed the mask by a factor more than  $\{10 \log (CS_{\min}/IF_{bw}) - 10\}$  dB
- be spaced each other in frequency by less than  $CS_{\min}$

Where:

$CS_{\min} = 3\,500$  kHz for the 50 GHz band

$IF_{bw}$  is the recommended resolution IF bandwidth, expressed in kHz, reported in table 2.

Figure 3 shows a typical example of this requirement.

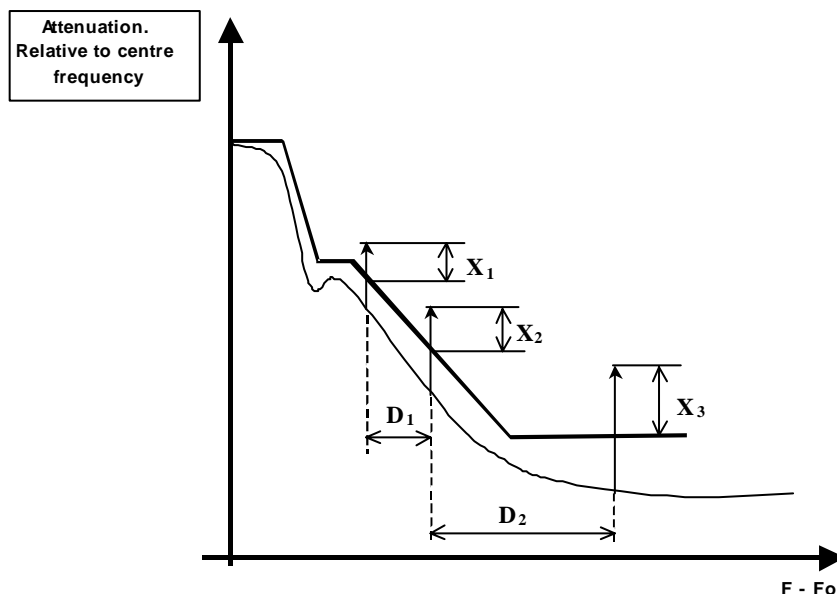

$$X_1, X_2, X_3 \text{ [dB]} \leq 10 \log( CS_{\min} / IF_{bw} ) - 10$$

$$D_1, D_2 \geq CS_{\min}$$

Figure 3: CW lines exceeding the spectrum mask (typical example)

## 5.4.4 Spurious emissions

According to ITU-R Recommendation F.1191-1 [12] and CEPT/ERC 74-01 [13], the external spurious emissions are defined as emissions at frequencies which are outside the nominal carrier frequency  $\pm 250\%$  of the relevant channel separation.

The limits of these emissions shall conform to CEPT/ERC Recommendation 74-01 [13].

## 5.4.5 RF tolerance

RF tolerance is not included in the spectrum mask. Maximum allowable RF tolerance shall not exceed  $\pm 10$  ppm for class 2 equipment and for class 1 equipment the maximum allowable tolerance shall not exceed  $\pm 20$  ppm.

## 5.5 Receiver characteristics

### 5.5.1 Input level range

The input level range for a BER  $< 10^{-3}$  shall extend from the upper limit of  $-20$  dBm to the lower threshold for BER =  $10^{-3}$ , referred to point C.

### 5.5.2 Spurious emissions

The limits of these emissions shall conform to CEPT/ERC Recommendation 74-01 [13].

NOTE: When waveguide is used between reference point A' and C' (figure 1), whose length is greater than twice the wavelength of the cut off frequency ( $f_c$ ), the lower limit of measurement will be increased to  $0,7 f_c$ . If the length is greater than four times the wavelength the lower limit of measurement will be increased to  $0,9 f_c$ .

## 5.6 System performance

### 5.6.1 BER performance

BER versus receive signal power level should be referred to point C of the system diagram (see figure 1).

**Table 3: Receiver Sensitivity**

System Class	Channel spacing (MHz)	Bit rate (Mbit/s)	BER 10 <sup>-3</sup> level (dBm)	BER 10 <sup>-6</sup> level (dBm)
1	7	2	-75	-72
	14	2 x 2	-72	-69
	28	4 x 2 or 8	-69	-66
2	3,5	2	-81	-78
	3,5	2 x 2	-78	-75
	7	4 x 2 or 8	-75	-72
	14	8 x 2 or 2 x 8	-72	-69
	28	16 x 2 or 34	-69	-66

### 5.6.2 Equipment background BER

The equipment background BER level range under simulated operating conditions without interference is measured with a signal level at point C which is between 15 dB and 40 dB above the level which gives BER = 10<sup>-3</sup>. The measurement period should not be less than 15 hours (all measurements are made at the system bit rate).

For systems less than 34 Mbit/s: BER <10<sup>-10</sup>.

For systems of 34 Mbit/s and above: BER <10<sup>-11</sup>.

### 5.6.3 Interference sensitivity

All receive signal levels and S/I measurements should be referred to point C of the system diagram (see figure 1).

#### a) Co-channel interference

The limits of co-channel interference shall be as in table 4, giving maximum S/I values for 1 dB and 3 dB degradation at the 10<sup>-6</sup> BER limits specified in clause 5.6.1.

**Table 4: Co-channel Interference Sensitivity**

System Class	Bit rate (Mbit/s)	Channel spacing (MHz)	RSL @ BER	
			Degradation	
			RSL @ 10 <sup>-6</sup>	
			1 dB	3 dB
1	2	7	23	19
	2 x 2	14	23	19
	4 x 2 or 8	28	23	19
2	2	3,5	23	19
	2 x 2	3,5	23	19
	4 x 2 or 8	7	23	19
	8 x 2 or 2 x 8	14	23	19
	16 x 2 or 34	28	23	19

#### b) Adjacent channel interference

The limits of adjacent channel interference shall be as in table 5, for like modulated signals spaced by 1 channel, giving maximum S/I values for 1 dB and 3 dB degradation at the 10<sup>-6</sup> BER limits specified in clause 5.6.1.

Table 5: Adjacent channel interference

			RSL @ BER	
			Degradation	
System Class	Bit rate (Mbit/s)	Channel spacing (MHz)	RSL @ 10 <sup>-6</sup>	
			1 dB	3 dB
1	2	7	0	-4
	2 x 2	14	0	-4
	4 x 2 or 8	28	0	-4
2	2	3,5	0	-4
	2 x 2	3,5	0	-4
	4 x 2 or 8	7	0	-4
	8 x 2 or 2 x 8	14	0	-4
	16 x 2 or 34	28	0	-4

NOTE 1: Regulatory administrations may wish to vary the value of S/I for co-polar, adjacent channel interference. Values of S/I are typically in the range 0 dB to -3 dB.

c) CW spurious interference

For a receiver operating at the 10<sup>-6</sup> BER threshold given in table 3, introduction of a CW interfere with a level of +27 dB or +30 dB, at the discretion of the administration, with respect to the 'wanted' signal and at any frequency in the range 30 MHz to 110 GHz, excluding frequencies either side of the wanted frequency by up to twice the relevant co-polar channel spacing, shall not result in a BER greater than 10<sup>-5</sup>.

This test is designed to identify specific frequencies at which the receiver may have a spurious response; e.g. image frequency, harmonics of the receive filter, etc. The test is not intended to imply a relaxed specification at all out-of-band frequencies.

NOTE 2: When waveguide is used between reference point A' and C' (figure 1), whose length is greater than twice the wavelength of the cut off frequency ( $f_c$ ), the lower limit of measurement will be increased to 0,7  $f_c$ . If the length is greater than four times the wavelength the lower limit of measurement will be increased to 0,9  $f_c$ .

## 5.6.4 Distortion sensitivity

Distortion sensitivity is not likely to be significant for short hop operation. Signatures for systems are not required.

---

## Bibliography

CCIR Report 338: "Propagation data and prediction methods required for terrestrial line-of-sight systems".

CCIR Report 563: "Radiometeorological data".

CCIR Report 721: "Attenuation by hydrometeors, in particular precipitation, and other atmospheric particles".

ETSI ETR 035: "Equipment Engineering (EE); Environmental engineering; Guidance and terminology".

---

## History

<b>Document history</b>		
V1.1.1	November 1999	Publication
V1.1.2	May 2000	Publication
V1.2.1	October 2000	One-step Approval Procedure      OAP 20010216: 2000-10-18 to 2001-02-16