

**Transmission and Multiplexing (TM);  
Digital Radio Relay Systems (DRRS);  
Frequency Division Multiple Access (FDMA);  
Point-to-multipoint DRRS in frequency bands  
in the range 1 GHz to 3 GHz**

---

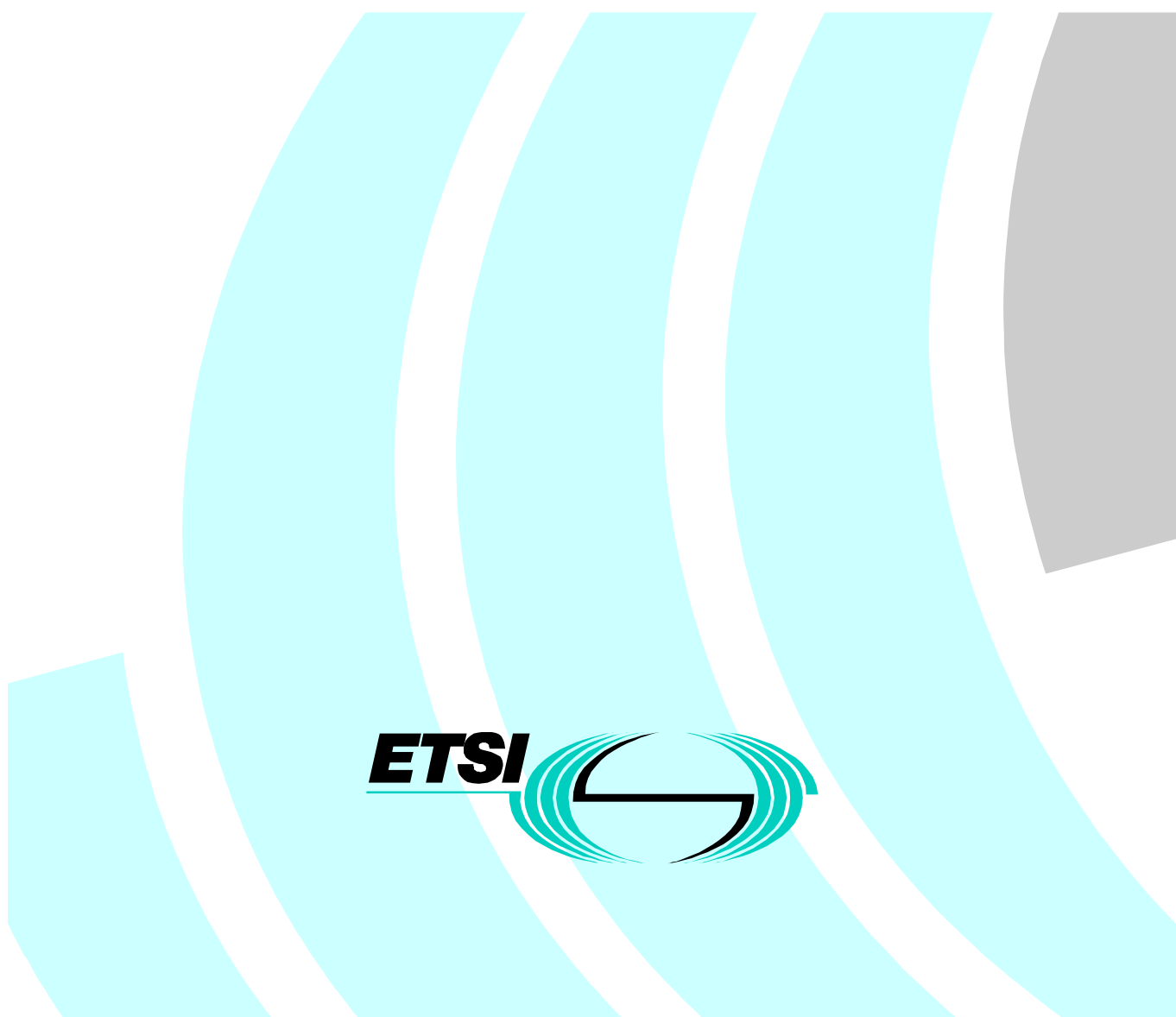

---

**Reference**

DEN/TM-04045 (cpo00ico.PDF)

---

**Keywords**

FDMA, multipoint, radio, RLL, transmission

**ETSI**

---

**Postal address**

F-06921 Sophia Antipolis Cedex - FRANCE

---

**Office address**

650 Route des Lucioles - Sophia Antipolis  
Valbonne - FRANCE  
Tel.: +33 4 92 94 42 00 Fax: +33 4 93 65 47 16  
Siret N° 348 623 562 00017 - NAF 742 C  
Association à but non lucratif enregistrée à la  
Sous-Préfecture de Grasse (06) N° 7803/88

---

**Internet**

secretariat@etsi.fr  
Individual copies of this ETSI deliverable  
can be downloaded from  
<http://www.etsi.org>  
If you find errors in the present document, send your  
comment to: editor@etsi.fr

---

**Important notice**

This ETSI deliverable may be made available in more than one electronic version or in print. In any case of existing or perceived difference in contents between such versions, the reference version is the Portable Document Format (PDF). In case of dispute, the reference should be the printing on ETSI printers of the PDF version kept on a specific network drive within ETSI Secretariat.

---

**Copyright Notification**

No part may be reproduced except as authorized by written permission.  
The copyright and the foregoing restriction extend to reproduction in all media.

© European Telecommunications Standards Institute 1999.  
All rights reserved.

# Contents

Intellectual Property Rights .....	5
Foreword .....	5
Introduction .....	5
1 Scope .....	7
1.1 Applications .....	7
1.2 Frequencies .....	7
1.3 Access Method .....	7
1.4 Compatibility .....	7
2 References .....	7
3 Definitions, symbols and abbreviations .....	9
3.1 Definitions .....	9
3.2 Symbols .....	9
3.3 Abbreviations .....	10
4 General System Architecture .....	11
4.1 Sub-System Types .....	11
4.2 System characteristics .....	12
4.2.1 System capacity .....	12
4.2.2 Transmission error performance .....	12
4.2.3 Round trip delay .....	12
4.2.4 Transparency .....	12
4.2.5 Voice coding methods .....	13
4.2.6 TMN interface .....	13
4.2.7 Synchronization .....	13
5 Radio characteristics .....	13
5.1 Frequency bands .....	13
5.2 Channel arrangement .....	14
5.3 Transmitter Characteristics .....	14
5.3.1 Tx power range .....	14
5.3.2 Spectrum mask .....	15
5.3.3 Transmitter spurious emissions .....	17
5.3.4 RF frequency tolerance .....	17
5.4 Receiver characteristics .....	18
5.4.1 Input level range .....	18
5.4.2 Spurious Emissions .....	18
5.4.3 BER as a function of receiver input signal level (RSL) .....	18
5.4.4 Interference sensitivity .....	19
5.4.4.1 Adjacent channel interference .....	19
5.4.4.2 Co-channel interference .....	20
5.4.4.3 CW spurious Interference .....	21
5.4.5 Distortion sensitivity .....	21
5.5 Antenna port characteristics .....	21
5.5.1 RF interface .....	21
5.5.2 Return loss .....	21
6 Types of user equipment interfaces and network interfaces .....	21
7 Power supply, environmental, and mechanical characteristics .....	22
7.1 Power supply .....	22
7.2 Environmental conditions .....	22
7.2.1 Equipment within weather protected locations .....	22
7.2.2 Equipment for non-weather protected locations .....	22
7.3 ElectroMagnetic Compatibility (EMC) Conditions .....	22

History..... 23

---

## Intellectual Property Rights

IPRs essential or potentially essential to the present document may have been declared to ETSI. The information pertaining to these essential IPRs, if any, is publicly available for **ETSI members and non-members**, and can be found in SR 000 314: "*Intellectual Property Rights (IPRs); Essential, or potentially Essential, IPRs notified to ETSI in respect of ETSI standards*", which is available from the ETSI Secretariat. Latest updates are available on the ETSI Web server (<http://www.etsi.org/ipr>).

Pursuant to the ETSI IPR Policy, no investigation, including IPR searches, has been carried out by ETSI. No guarantee can be given as to the existence of other IPRs not referenced in SR 000 314 (or the updates on the ETSI Web server) which are, or may be, or may become, essential to the present document.

---

## Foreword

This European Standard (Telecommunications series) has been produced by ETSI Technical Committee Transmission and Multiplexing (TM), and is now submitted for the Voting phase of the ETSI standards Two-step Approval Procedure.

The present document contains the minimum technical requirements to ensure compatibility of products and conformance with radio regulations across ETSI member states. Radio terminals from different manufacturers are not required to interwork at radio frequency (i.e. no common air interface).

The present document defines the requirements for radio-relay equipment and associated interfaces.

The present document is intended to cover a variety of systems designed for a variety of services, applications, performance objectives and deployment conditions. Therefore it is necessary to include in the present document different sets of system parameters. In the present document these sets of parameters are referred to as "system types".

In addition to the changes resulting from Public Enquiry, following the publication of CEPT/ERC Recommendation 74-01 [2], clause 2 and subclauses 5.3.3, 5.4.2 and 7.3 have been modified and the resulting changes are highlighted by the use of revision marks.

<b>Proposed national transposition dates</b>	
Date of latest announcement of this EN (doa):	3 months after ETSI publication
Date of latest publication of new National Standard or endorsement of this EN (dop/e):	6 months after doa
Date of withdrawal of any conflicting National Standard (dow):	6 months after doa

---

## Introduction

The main field of application of Point-to-Multipoint (P-MP) Systems is to provide access to both public and private networks (PSTN, PDN, ...). By means of P-MP systems the network service area may be extended to cover both distant and scattered user locations; and the systems may be applied to build new access networks covering both urban and rural areas.

Users are offered the full range of services by the particular public or private network. Users have access to these services by means of the various standardized user network interfaces (2-wire loop, new data services and ISDN).

P-MP systems provide standard network interfaces and transparently connect users to the appropriate network node. These systems allow a service to be connected to a number of users ranging from a few to several thousands and over a wide range of distances.

Point-to-Multipoint systems are generally configured as Pre-Assigned Systems or as Demand Assigned Multiple Access (DAMA) Radio Systems.

The essential features of a typical P-MP DAMA Radio Systems are:

- efficient use of the radio spectrum;
- concentration;
- transparency.

Radio is often the ideal way of obtaining communications at low cost and almost independent of distance, and difficult topography. Moreover, a small number of sites are required for these installations, thus facilitating rapid implementation and minimizing maintenance requirements of the systems.

Concentration means that  $m$  users can share  $n$  radio channels ( $m$  being larger than  $n$ ), allowing a better use to be made of the available frequency spectrum and at a lower equipment cost. The term "multi-access" means that every user has access to every channel (instead of a fixed assignment as in most multiplex systems). When a call is initiated one of the available channels is allocated to it. When the call is terminated, the channel is released for another call.

Concentration requires the use of distributed intelligent control which in turn allows many other operation and maintenance functions to be added.

Transparency means that the exchange and the user equipment communicate with each other without being aware of the radio link.

---

# 1 Scope

## 1.1 Applications

The scope of the present document covers the following point-to-multipoint applications:

- voice;
- fax;
- voiceband data;
- telex;
- data up to 64 kbit/s;
- ISDN.

## 1.2 Frequencies

The present document covers fixed point-to-multipoint services operating in the 1,5 GHz, 2,2 GHz, 2,4 GHz and 2,6 GHz bands.

The frequency plans for the 1,5 GHz, 2,2 GHz and 2,6 GHz bands are given in CEPT/ERC Recommendation T/R 13-01 [1]. For the 2,4 GHz band, the ITU-R Recommendation F.701-2 [11] is applicable.

## 1.3 Access Method

The present document covers Frequency Division Multiple Access (FDMA) systems.

## 1.4 Compatibility

There is no requirement to operate a Central Station (CS) from one manufacturer with a Terminal Station (TS) or a Repeater Station (RS) from another manufacturer.

---

# 2 References

The following documents contain provisions which, through reference in this text, constitute provisions of the present document.

- References are either specific (identified by date of publication, edition number, version number, etc.) or non-specific.
- For a specific reference, subsequent revisions do not apply.
- For a non-specific reference, the latest version applies.
- A non-specific reference to an ETS shall also be taken to refer to later versions published as an EN with the same number.

[1] CEPT/ERC Recommendation T/R 13-01: "Preferred channel arrangements for fixed services in the range 1 GHz to 3 GHz".

[2] CEPT/ERC Recommendation 74-01: "Spurious Emissions".

- [3] ETS 300 012: "Integrated Services Digital Network (ISDN); Basic user-network interface Layer 1 specification and test principles".
- [4] ETS 300 019: "Equipment Engineering (EE); Environmental conditions and environmental tests for telecommunications equipment".
- [5] ETS 300 132: "Equipment Engineering (EE); Power supply interface at the input to telecommunications equipment".
- [6] ETS 300 324 Parts 1 to 5 and Part 7 (1994): "V interfaces at the digital Local Exchange (LE); V5.1 interface for the support of Access Network (AN); Part 1: V5.1 interface specification; Part 2: Protocol Implementation Conformance Statement (PICS) proforma; Part 3: Test Suite Structure and Test Purposes (TSS&TP) specification for the network layer (AN side); Part 4: Abstract Test Suite (ATS) and partial Protocol Implementation eXtra Information for Testing (PIXIT) proforma specification for the network layer (AN side); Part 5: Test Suite Structure and Test Purposes (TSS&TP) specification for the network layer (LE side); Part 7: Test Suite Structure and Test Purposes (TSS&TP) specification for the data link layer".
- [7] ETS 300 347 Parts 1 and 2 (1994): "V interfaces at the digital Local Exchange (LE); V5.2 interface for the support of Access Network (AN); Part 1: V5.2 interface specification; Part 2: Protocol Implementation Conformance Statement (PICS) proforma".
- [8] EN 300 385 (V1.2): "Electromagnetic compatibility and Radio spectrum Matters (ERM); ElectroMagnetic Compatibility (EMC) standard for fixed radio links and ancillary equipment".
- [9] EN 301 390: "Transmission and Multiplexing (TM); Digital Radio Relay Systems (DRRS); Spurious emissions and receiver immunity at equipment antenna ports of DRRS".
- [10] ITU-R Recommendation F.697-2 (1997): "Error performance and availability objectives for the local-grade portion at each end of an ISDN connection at a bit rate below the primary rate utilizing digital radio-relay systems".
- [11] ITU-R Recommendation F.701-2 (1997): "Radio-frequency channel arrangements for analogue and digital point-to-multipoint radio systems operating in frequency bands in the range 1 350 to 2 690 GHz (1,5, 1,8, 2,0, 2,2, 2,4 and 2,6 GHz)".
- [12] ITU-T Recommendation G.131 (1996): "Control of talker echo".
- [13] ITU-T Recommendation G.703 (1998): "Physical/electrical characteristics of hierarchical digital interfaces".
- [14] CCITT Recommendation G.711 (1988): "Pulse code modulation (PCM) of voice frequencies".
- [15] ITU-T Recommendation G.813 (1996): "Timing characteristics of SDH equipment slave clocks (SEC)".
- [16] ITU-T Recommendation G.726 (1990): "40, 32, 24, 16 kbit/s adaptive differential pulse code modulation (ADPCM)".
- [17] ITU-T Recommendation G.728 (1992): "Coding of speech at 16 kbit/s using low-delay code excited linear prediction".
- [18] ITU-T Recommendation G.729 (1996): "Coding of speech at 8 kbit/s using conjugate-structure algebraic-code-excited linear-prediction".
- [19] ITU-T Recommendation G.773 (1993): "Protocol suites for Q-interfaces for management of transmission systems".
- [20] ITU-T Recommendation G.810 (1996): "Definitions and terminology for synchronization networks".
- [21] ITU-T Recommendation G.812 (1998): "Timing requirements of slave clocks suitable for use as node clocks in synchronization networks".



- [22] ITU-T Recommendation G.821 (1996): "Error performance of an international digital connection operating at a bit rate below the primary rate and forming part of an integrated services digital network".
- [23] ITU-T Recommendation G.823 (1993): "The control of jitter and wander within digital networks which are based on the 2 048 kbit/s hierarchy".
- [24] ITU-T Recommendation G.825 (1993): "The control of jitter and wander within digital networks which are based on the synchronous digital hierarchy (SDH)".
- [25] ITU-T Recommendation G.961 (1993): "Digital transmission system on metallic local lines for ISDN basic rate access".
- [26] ITU-T Recommendation O.151 (1992): "Error performance measuring equipment operating at the primary rate and above".
- [27] ITU-T Recommendation O.181 (1996): "Equipment to assess error performance on STM-N interfaces".
- [28] ITU-T Recommendation Q.552 (1996): "Transmission characteristics at 2-wire analogue interfaces of digital exchanges".
- [29] ITU-T Recommendation Q.553 (1996): "Transmission characteristics at 4-wire analogue interfaces of digital exchanges".
- [30] CCITT Recommendation R.20 (1988): "Telegraph modem for subscriber lines".
- [31] ITU-T Recommendation V series: "Data communication over the telephone network".

## 3 Definitions, symbols and abbreviations

### 3.1 Definitions

For the purposes of the present document, the following terms and definitions apply:

**Full capacity load (FCL):** maximum number of 64 kbit/s signals or the equivalent which can be transmitted and received by a single CRS within a specified RF-bandwidth, to be used for conformance test procedures.

**round trip delay:** sum of the delay between point F to G plus G to F in figure 1 including any repeaters as appropriate.

**nominal output power:** maximum output power of the Central Radio Station, Terminal Station or Repeater Station referred to point C' (figure 2) under Full Load Condition, as declared by the manufacturer.

### 3.2 Symbols

For the purposes of the present document, the following symbols apply:

dB	decibel
dBm	decibel relative to 1 milliwatt
GHz	GigaHertz
Hz	Hertz
kbit/s	kilobit per second
kHz	kiloHertz
Mbit/s	Megabit per second
MHz	MegaHertz
ms	millisecond

### 3.3 Abbreviations

For the purposes of the present document, the following abbreviations apply:

ADPCM	Adaptive Differential Pulse Code Modulation
ATPC	Automatic Transmission Power Control
BER	Bit Error Ratio
CCS	Central Controller Station
CRS	Central Radio Station
CS	Central Station
DAMA	Demand Assignment Multiple Access
EMC	ElectroMagnetic Compatibility
FDMA	Frequency Division Multiple Access
$f_s$	RF-channel spacing
ISDN	Integrated Services Digital Network
P-MP	Point-to-Multipoint
PRBS	Pseudo Random Bit Sequence
RF	Radio Frequency
RS	Repeater Station
RSL	Received Signal Level
TE	Terminal Equipment
TMN	Telecommunications Management Network
TS	Terminal Station

## 4 General System Architecture

A system could consist of physical sub-systems as follows (see figure 1):

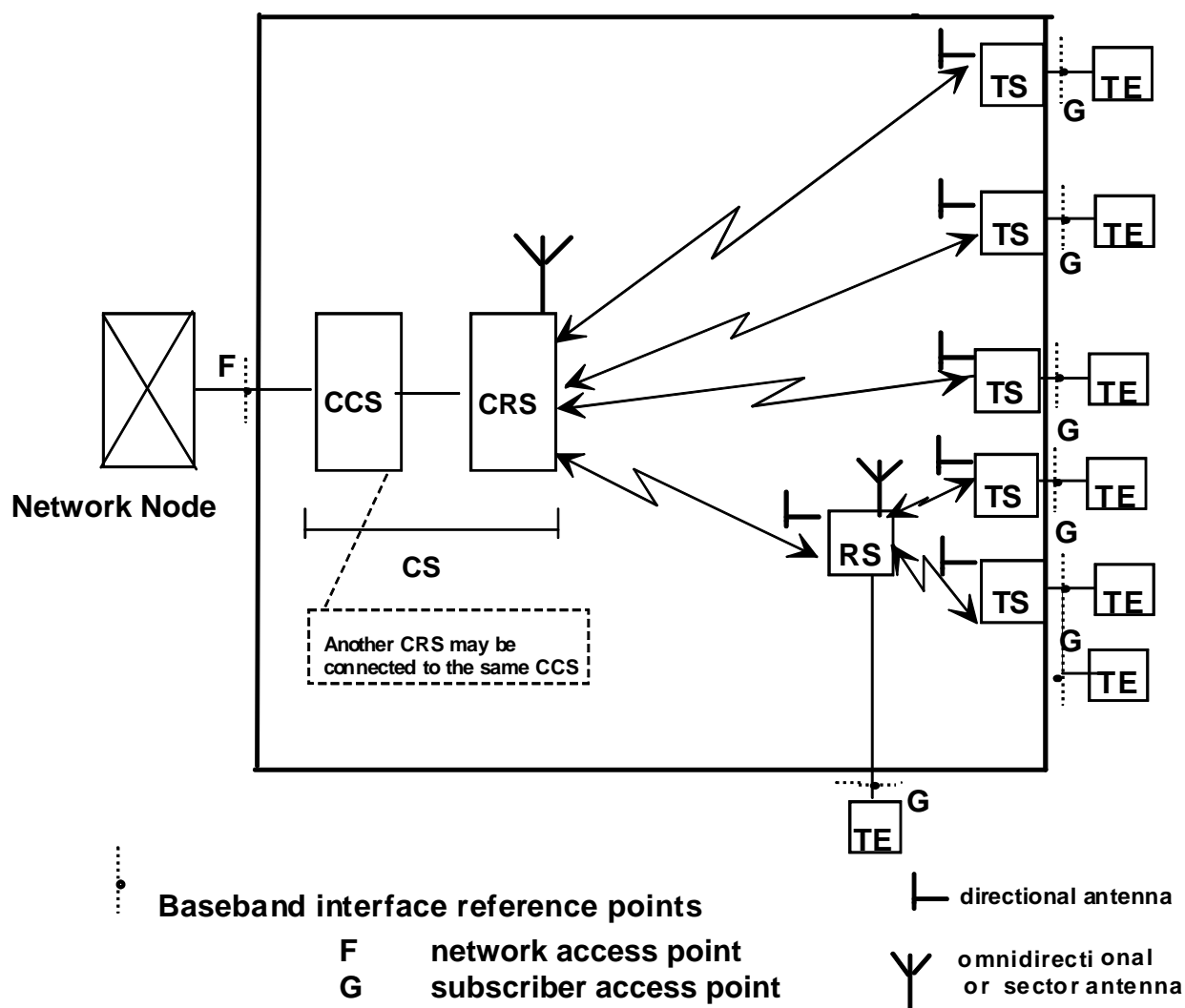

Figure 1: General System Architecture

### 4.1 Sub-System Types

CS: Central Station which may be subdivided in to two units:

CCS: Central Controller Station which provides the interface to the network node;

CRS: Central Radio Station which is the central base station containing at least the radio transceiver equipment providing the interface to the terminal station via the air. Each transceiver is connected to a separate antenna. This is used e.g. if sectored cells are applied to increase the capacity of each cell;

TS: Terminal station which provides the interfaces to the user equipment.

RS: Repeater Station which may also provide the interfaces to the user, if applicable. A RS may serve one or more TSs.

F: Point of connection to the Network Node.

G: Point(s) of connection to the user equipment.

TE: Terminal (User) Equipment.

NOTE 1: Central Controller Station (CCS) may control more than one Central Radio Station (CRS).

NOTE 2: A TS may serve more than one TE.

The central station performs the interconnection with the network node (local exchange) carrying out a concentration function by sharing the total number of available channels in the system. The central station is linked by microwave transmission paths to each Terminal Station (TS) either directly or via one or more Repeater Stations (RS).

Whenever an existing digital transmission link is available, the network implementation can be optimized by separating the CCS, installed at the exchange site, and the CRS.

The general characteristics which are typical for point-to-multipoint systems are considered in the present document. These characteristics have been categorized under four headings.

- 1) system characteristics;
- 2) radio characteristics;
- 3) type of user and exchange interfaces;
- 4) power supply and environmental characteristics.

## 4.2 System characteristics

### 4.2.1 System capacity

The system capacity parameter considered in the present document is the transmission capacity of the CRS, which is the maximal payload bit rate transmitted over the air between a given CRS and its associated remote stations (TSs and RSs).

### 4.2.2 Transmission error performance

Equipment shall be able to meet network performance and availability requirements specified by ITU-T Recommendation G.821 [22] following the criteria defined in ITU-R Recommendation F.697-2 [10] for the local grade portion of the digital connection.

### 4.2.3 Round trip delay

The round trip delay for a 64 kbit/s traffic channel shall not exceed 20 ms.

Longer round trip delays may result at other bit rates and when using speech coding at rates lower than 64 kbit/s.

In order to guarantee that the delay, introduced by the system into the transmission network does not degrade the quality of the telephone communication, compliance to ITU-T Recommendation G.131 [12] shall be ensured. Where echo cancellers are used, the characteristics shall be declared by the manufacturer.

### 4.2.4 Transparency

The system shall be fully transparent: The network node and the user equipment (points F and G in figure 1) communicate with each other without being aware of the radio link.

## 4.2.5 Voice coding methods

At least one of the following standard coding methods could be employed:

- 64 kbit/s CCITT Recommendation G.711 [14] (which will provide full transparency and permit a direct digital interface to digital switches);
- 32 kbit/s ITU-T Recommendation G.726 [16];
- 16 kbit/s ITU-T Recommendation G.728 [17];
- 8 kbit/s ITU-T Recommendation G.729 [18].

Other voice coding methods may be employed if the quality for voice transmission is adequate. The coding method used shall be declared by the manufacturer.

## 4.2.6 TMN interface

TMN interface, if any, should be in accordance with ITU-T Recommendation G.773 [19].

## 4.2.7 Synchronization

Systems employing digital interfaces shall include methods enabling internal and external synchronization to the network. The principles for synchronization shall be met according to ITU-T Recommendation G.810 [20]. Tolerances shall be according to ITU-T Recommendations G.812 [21] and G.823 [23] for systems providing PDH interfaces and/or ITU-T Recommendations G.813 [15] and G.825 [24] for systems providing SDH interfaces.

---

# 5 Radio characteristics

## 5.1 Frequency bands

Bands allocated to the Fixed Service in the range 1 GHz to 3 GHz shall be used according to CEPT/ERC Recommendation T/R 13-01 [1] annex A to D and/or ITU-R Recommendation F.701-2 [11] stated in table 1.

**Table 1: Frequency bands**

Frequency band/GHz	Band limits /MHz	Recommendation	Transmit / receive spacing / MHz	Channel spacing / MHz
1,5 (I)	1 350 to 1 375 paired with 1 492 to 1 517	CEPT/ERC Recommendation T/R 13-01 [1] annex A	142	1; 2; 3,5
1,5 (II)	1 375 to 1 400 paired with 1 427 to 1 452	CEPT/ERC Recommendation T/R 13-01 [1] annex B	52	1; 2; 3,5
2,2	2 025 to 2 110 paired with 2 200 to 2 290	CEPT/ERC Recommendation T/R 13-01 [1] annex C	175	1,75; 3,5; 7; 14
2,4	2 300 2 500	ITU-R Recommendation F.701-2 [11]	94	n x 0,5
2,6	2 520 to 2 593 paired with 2 597 to 2 670	CEPT/ERC Recommendation T/R 13-01 [1] annex D	74	1,75; 3,5; 7; 14

## 5.2 Channel arrangement

The system shall meet at least one of the channel arrangement shown in table 2.

**Table 2: CRS Channel**

Channel spacing (MHz)	1	1,75	2	3,5	7	14
Minimum CRS transmission capacity (kbit/s) 4 state modulation (or equivalent)	12 x 64	21 x 64	24 x 64	42 x 64	84 x 64; 4 x 2 048	8 x 2 048
Minimum CRS transmission capacity (kbit/s) 8 state modulation (or equivalent)	18 x 64	31 x 64	36 x 64	62 x 64	5 x 2 048	10 x 2 048
Minimum CRS transmission capacity (kbit/s) 16 state modulation (or equivalent)	24 x 64	42 x 64	48 x 64	84 x 64; 4 x 2 048	8 x 2 048	16 x 2 048

NOTE 1: "or equivalent" means: providing the same capacity regardless of the actual modulation scheme.

NOTE 2: Any other equivalent transmission capacity may be transported, e.g. instead of 42 x 64 Kbit/s a capacity of 21 x 128 Kbit/s can be transmitted.

NOTE 3: Administrations may allow equipment to operate at lower bandwidth and capacities than indicated in table 2 achieved by subdivision of the channel spacing (table 1) of equipment approved for 1,75 / 2 MHz channel operation.

## 5.3 Transmitter Characteristics

All transmitter characteristics refer to systems under every load conditions. Measurement of those characteristics shall be made when the CRS is under full load conditions to be declared by the manufacturer.

Full load conditions is defined as the maximum number of 64 kbits/s signals, or equivalent, which can be transmitted and received by a single CRS within a specific RF bandwidth, fulfilling performance objectives.

A BER lower or equal than for BER of  $10^{-6}$  shall be achieved at the threshold receive level stated in subclause 5.4.3 for BER  $10^{-6}$ .

The specified transmitter characteristics shall be met with the appropriate input signals applied at point F or G of figure 1. For the PDH interface this shall be in accordance with ITU-T Recommendation O.151 [26] and for SDH interfaces in accordance with ITU-T Recommendation O.181 [27].

### 5.3.1 Tx power range

Maximum output power for a single FDMA signal, averaged whilst the transmitter is enabled, shall not exceed +33 dBm at point C' of system block diagram (figure 2).

The manufacturer shall declare the nominal output power for the CRS, TS and RS under full load conditions.

If a lower transmitter output power is required, then an internal or external means of adjustment shall be provided.

The transmitted output power means the value measured where the output is connected to a dummy load i.e. power meter or spectrum analyser. The transmitted carrier is modulated with a signal representing normal traffic.

Two different measurement methods can be used:

- 1) spectrum analyser with resolution BW and VBW greater than 1 MHz;
- 2) power meter.

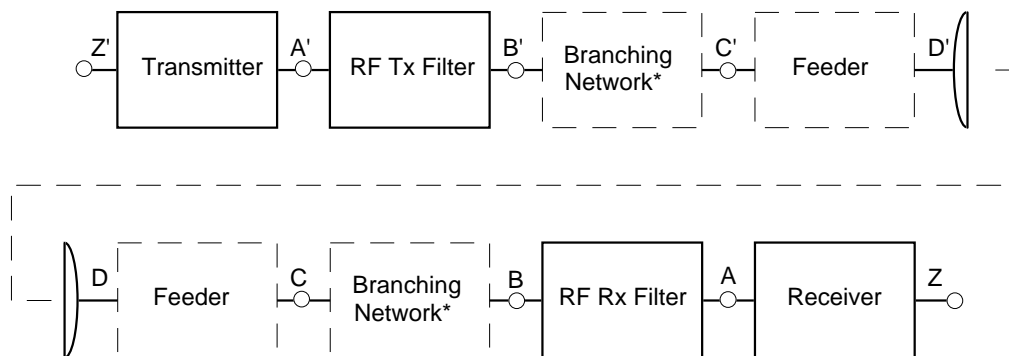

NOTE: Points B & C and B' and C' will coincide if branching networks are not used.

**Figure 2: RF System Block diagram**

### 5.3.2 Spectrum mask

Spectrum mask is given in figure 3.

General test load conditions to measure the spectrum mask for the CRS transceiver:

- Number (N) of carriers transmitted over one CRS transceiver should correspond with the FCL of the measured CRS. The number N shall be declared by the manufacturer;
- the output power for each carrier shall be  $1/N$  of the nominal output power of the CRS referred to point C';
- the capacity of the CRS shall be equally distributed among the N single carriers.

NOTE: Under operational conditions the output power of some carriers may be greater than  $1/N$  of the nominal output power.

Relative spectral  
power density  
[dB]

### Spectrum mask for the CRS referred to point C'

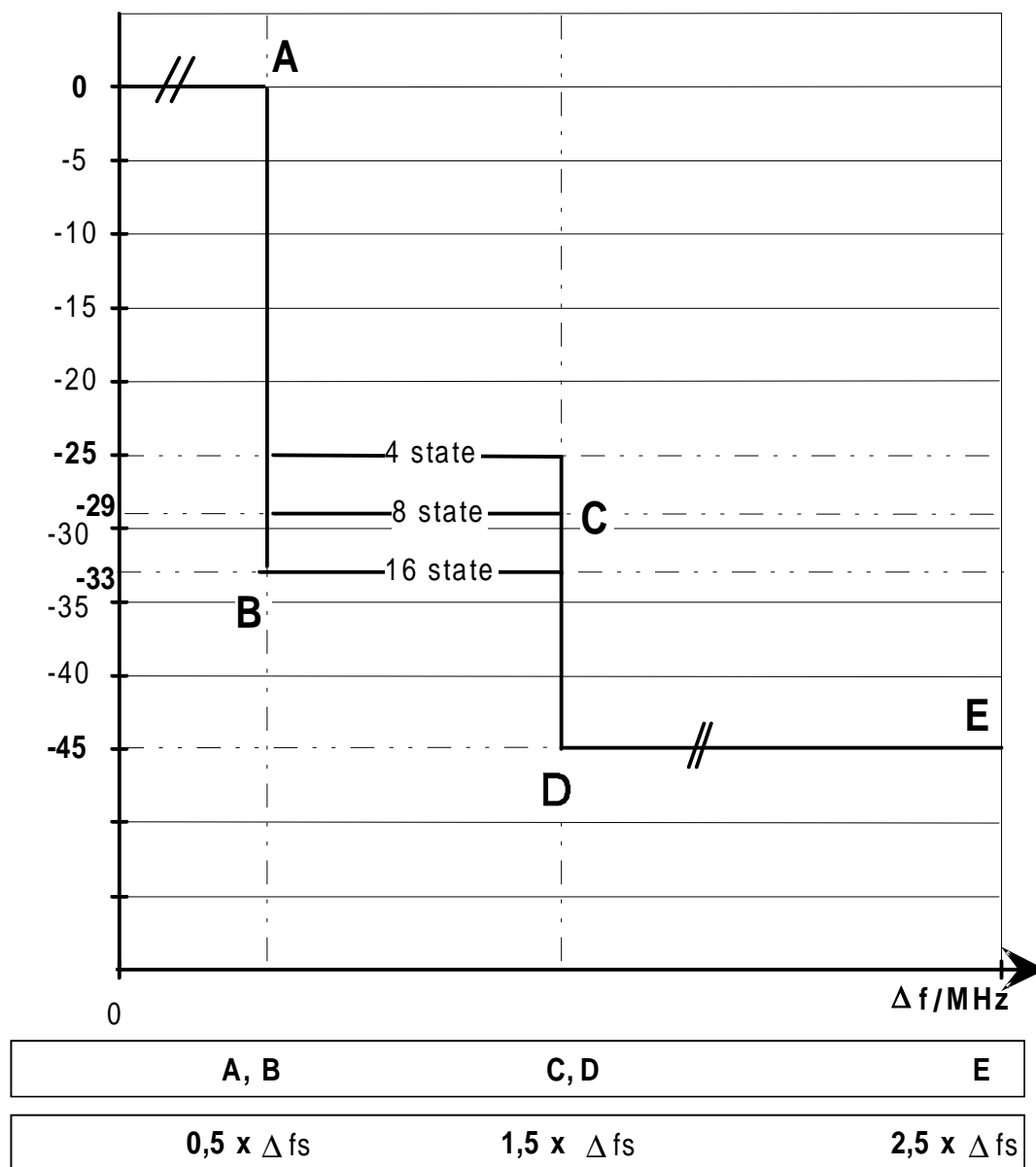

$\Delta f_s$ : RF-channel spacing (co-polar) between the centre frequencies of two adjacent CRS.

**Figure 3: Spectrum mask**

NOTE: Frequency tolerance is not included in the spectrum mask.

Where subdivision is used the spectrum masks of contiguous narrower band channels according to note 3 of subclause 5.2 (e.g. two channels) shall fit into the spectrum mask of wider band channel (e.g. one 1,75 MHz channel figure 4).



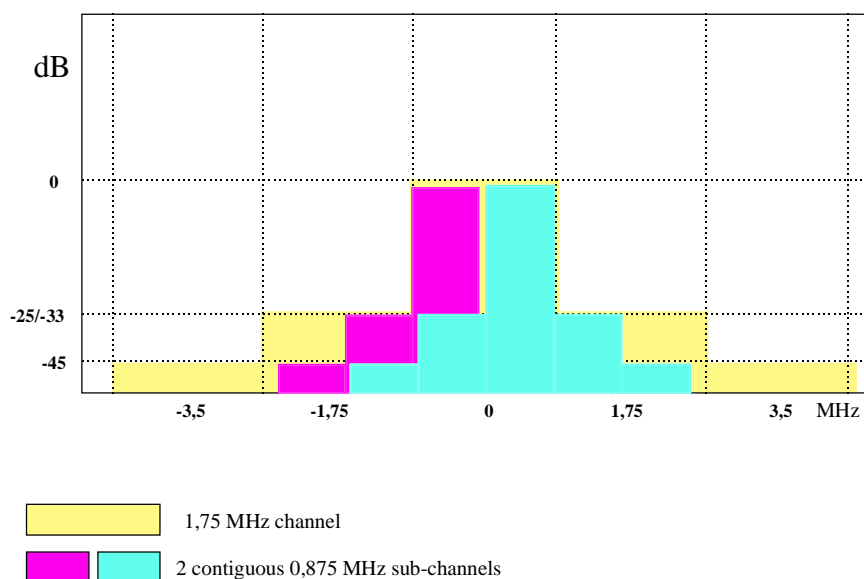

**Figure 4: Arranging of two contiguous sub-channels into one 1,75 MHz channel (example)**

The reference level of the output spectrum means that the 0 dB level is the top of the modulated spectrum, disregarding the residual carrier.

**Table 3: Spectrum Analyser Settings**

Resolution BW	Video BW	Sweep time
30 kHz	300 Hz	10 s

The spectrum measurement referenced to point C' of RF-system block diagram shall be performed with the maximum hold function on the spectrum analyser selected.

### 5.3.3 Transmitter spurious emissions

According to CEPT/ERC Recommendation 74-01 [2] the spurious emissions are defined as emissions at frequencies which are removed from the nominal carrier frequency more than  $\pm 250\%$  of the relevant channel separation.

Outside the band of  $\pm 250\%$  of the relevant channel separation (CS), the Fixed Service radio systems spurious emission limits, defined by CEPT/ERC Recommendation 74-01 [2] together with the frequency range to consider for conformance measurement, shall apply at reference point C'.

### 5.3.4 RF frequency tolerance

The maximum radio frequency tolerances shall not exceed  $\pm 20$  ppm. Since this limit includes short term factors (environmental effects) and long term ageing effects the manufacturer shall state the guaranteed short-term part and the expected ageing part for type test.

## 5.4 Receiver characteristics

### 5.4.1 Input level range

The input level range shall be large enough to enable the system to maintain its performance under the entire range of pass loss values the system is defined to cope with.

NOTE: If the ATPC option is incorporated within the system, the receiver input level range might be smaller than the path loss range.

### 5.4.2 Spurious Emissions

At reference point C, the limit values of CEPT/ERC Recommendation 74-01 [2] shall apply.

### 5.4.3 BER as a function of receiver input signal level (RSL)

For systems types A, each FDMA receiver input signal level at the BER thresholds (dBm) referred to point C (figure 2) for BER of  $10^{-3}$  and  $10^{-6}$  shall be equal to or lower than those stated in table 5. BER performance refer to system under full load conditions.

The BER performance shall be measured from the CRS to the TS (Outbound) and from the TS to the CRS (Inbound).

**Table 5: BER performance thresholds for different modulation schemes (system types A) for 2 Mbit/s**

Bit rate	RSL / dBm for BER $\leq 10^{-3}$			RSL / dBm for BER $\leq 10^{-6}$		
	Modulation states			Modulation states		
	4	8	16	4	8	16
2Mbit/s 16	-100	-99	-94	-97,5	-96,5	-91,5

Applying other bit rates the relevant receive levels may be calculated according to the following formulas:

- 4-state modulation schemes (or equivalent) ( system types A):
  - $P_e = -103 + 10 \times \log_{10}(\text{bit rate in Mbit/s})$  dBm for BER  $10^{-3}$ ;
  - $P_e = -100,5 + 10 \times \log_{10}(\text{bit rate in Mbit/s})$  dBm for BER  $10^{-6}$ .
- 8-state modulation schemes (or equivalent) (system types A):
  - $P_e = -102 + 10 \times \log_{10}(\text{bit rate in Mbit/s})$  dBm for BER  $10^{-3}$ ;
  - $P_e = -99,5 + 10 \times \log_{10}(\text{bit rate in Mbit/s})$  dBm for BER  $10^{-6}$ .
- 16-state modulation schemes (or equivalent) (system types A):
  - $P_e = -97 + 10 \times \log_{10}(\text{bit rate in Mbit/s})$  dBm for BER  $10^{-3}$ ;
  - $P_e = -94,5 + 10 \times \log_{10}(\text{bit rate in Mbit/s})$  dBm for BER  $10^{-6}$ .

For systems types B, each FDMA receiver input signal level at the BER thresholds (dBm) referred to point C (figure 2) for BER of  $10^{-3}$ , and  $10^{-6}$  shall be equal to or lower than those stated in table 6. BER performance refer to system under full load conditions.

The BER performance should be measured from the CRS (transceiver) to the TS (Outbound) and from the TS to the CRS (Inbound).

**Table 6: BER performance thresholds for different modulation schemes ( system types B)**

RSL	RSL (dBm) for BER $\leq 10^{-3}$			RSL (dBm) for BER $\leq 10^{-6}$		
Bit rate (kbit/s)	Modulation states			Modulation states		
----	4	8	16	4	8	16
16	-111	-108	-105	-107	-104	-100
32	-108	-105	-102	-104	-101	-97
64	-105	-102	-99	-101	-98	-94
128	-102	-99	-96	-98	-95	-91

Applying other bit rates the relevant receive levels may be calculated according the following formulas:

- 4-state modulation schemes (system types B):
  - $P_e = -93 + 10 \times \log_{10}(\text{bit rate in Mbit/s})$  dBm for BER  $10^{-3}$ ;
  - $P_e = -89 + 10 \times \log_{10}(\text{bit rate in Mbit/s})$  dBm for BER  $10^{-6}$ .
- 8-state modulation schemes (system types B):
  - $P_e = -90 + 10 \times \log_{10}(\text{bit rate in Mbit/s})$  dBm for BER  $10^{-3}$ ;
  - $P_e = -86 + 10 \times \log_{10}(\text{bit rate in Mbit/s})$  dBm for BER  $10^{-6}$ .
- 16-state modulation schemes (system types B):
  - $P_e = -87 + 10 \times \log_{10}(\text{bit rate in Mbit/s})$  dBm for BER  $10^{-3}$ ;
  - $P_e = -82 + 10 \times \log_{10}(\text{bit rate in Mbit/s})$  dBm for BER  $10^{-6}$ .

## 5.4.4 Interference sensitivity

### 5.4.4.1 Adjacent channel interference

Adjacent channel interference is defined as the ability of the receiver to receive a wanted signal in the presence of a like unwanted signal which is one channel away.

The two signals shall be connected to the receiver input via a combiner, so that the impedance is matched to the nominal impedance.

The wanted signal shall be tuned to the receiver's nominal frequency and be modulated with a PRBS signal. The interfering signal shall be turned off while the wanted signal is adjusted to the level corresponding to BER =  $10^{-6}$  as specified in subclause 5.4.3.

The interfering signal shall be tuned one channel away from the wanted signal and be modulated with a PRBS signal which is un-correlated to the wanted signal.

The limits of adjacent channel interference (external) for system types A shall be as given in table 7 below for like modulated signals, giving maximum S/I values for 1 dB and 3 dB degradation of the  $10^{-6}$  BER limits specified in subclause 5.4.3.

**Table 7: Adjacent channel interference sensitivity (system types A)**

Threshold degradation	1 dB	3 dB
Description	S/I (dB) for BER = $10^{-6}$	
4 state modulation	-15,5	-19,5
8 state modulation	-13,5	-17,5
16 state modulation	-6,5	-10,5

For system types B the S/I values are stated in table 8.

**Table 8: Adjacent channel interference sensitivity (system types B)**

Threshold degradation	1 dB	3 dB
Description	S/I (dB) for BER = $10^{-6}$	
4 state modulation	-3	-7
8 state modulation	-3	-7
16 state modulation	-3	-7

NOTE: The unwanted signal is one CRS channel away.

#### 5.4.4.2 Co-channel interference

Co-channel interference is defined as the ability of the receiver to receive a wanted signal in the presence of a like unwanted signal on the same frequency.

The two signals shall be connected to the receiver input via a combiner, so that the impedance is matched to the nominal impedance of the system.

The wanted signal shall be tuned to the receiver's nominal frequency and modulated with a PRBS signal.

The interfering signal shall be turned off while the wanted signal is adjusted to the level corresponding to BER =  $10^{-6}$  as specified in subclause 5.4.3.

The interfering signal shall be tuned to the same frequency as the wanted signal and modulated with a PRBS signal which is un-correlated to the wanted signal.

The limits of co-channel interference (external) for system types A systems shall be as given in table 9 for like modulated signals, giving maximum S/I values for 1 dB and 3 dB degradation of the  $10^{-6}$  BER limits specified in subclause 5.4.3.

**Table 9: Co-channel Interference Sensitivity (System types A)**

Threshold degradation	1 dB	3dB
Description	S/I (dB) for BER = $10^{-6}$	
4 state modulation	17,5	13,5
8 state modulation	19,5	15,5
16 state modulation	26,5	22,5

For system types B systems the S/I values are stated in table 10.

**Table 10: Co-channel Interference Sensitivity (System types B)**

Threshold degradation	1 dB	3dB
Description	S/I (dB) for BER = $10^{-6}$	
4 state modulation	24	20
8 state modulation	27	23
16 state modulation	30	26

### 5.4.4.3 CW spurious Interference

The immunity of the receiver(s) to CW spurious interference is defined in EN 301 390 [9]. This test is designed to identify specific frequencies at which the receiver may have a spurious response; e.g.; image frequency, harmonics of the receive filter, etc. The actual test range should be adjusted accordingly. The test is not intended to imply a relaxed specification at all out of band frequencies elsewhere specified in the present document.

For a receiver operating at the  $10^{-6}$  BER threshold as given in subclause 5.4.3, the introduction of a CW interferer at a level of +30 dB, with respect to the 'Wanted' signal at any frequency in the range 1 GHz to 40 GHz, excluding frequencies on either side of the 'wanted frequency' (RF-channel spacing) till up to  $\pm 450\%$  the co-polar channel spacing, shall not result in a BER greater than  $10^{-5}$ .

### 5.4.5 Distortion sensitivity

Distortion sensitivity due to multipath fading is not considered in the present document.

## 5.5 Antenna port characteristics

### 5.5.1 RF interface

If the RF interface (points C and C' in figure 2) is accessible, it shall be coaxial 50  $\Omega$  type (subclause 5.5.2).

### 5.5.2 Return loss

If RF interfaces at point C/C' is used to interconnect different manufacturers systems the return loss at those points shall be at least 15 dB at the reference impedance.

---

## 6 Types of user equipment interfaces and network interfaces

Table 11 lists a range of interfaces for various voice and data services. At least one of these interfaces shall be implemented in a point-to-multipoint system covered by the present document.

**Table 11: Types of interfaces**

<b>User Equipment Interfaces</b>	
Analogue (2 wires)	ITU-T Recommendation Q.552 [28]
Analogue (4 W + E & M)	ITU-T Recommendation Q.553 [29]
Telex	CCITT Recommendation R.20 [30] and V-series [31]
Digital data port	ITU-T Recommendation G.703 [13], X and V series
ISDN basic rate- S interface	ETS 300 012 [3] (note 1)
ISDN basic rate - U interface	ITU-T Recommendation G.961 [25]
<b>Network Interfaces</b>	
2 Mbit/s	ITU-T Recommendation G.703 [13]
Analogue (2 wires)	ITU-T Recommendation Q.552 [28]
Analogue (4 W + E & M)	ITU-T Recommendation Q.553 [29]
Telex	CCITT Recommendation R.20 [30] and V Series [31]
Digital data port	ITU-T Recommendation G.703 [13], X and V series
ISDN basic rate - S interface	ETS 300 012 [3] (note 2)
ISDN basic rate - U interface	ITU-T Recommendation G.961 [25]
ISDN + Analogue subscribers + Leased lines 2 Mbit/s Interface	V5.1/V5.2 (ETS 300 324 [6] / ETS 300 347 [7]), ITU-T Recommendation G.703 [13]
NOTE 1: ETS 300 012 [3] defines the S ISDN interface which is a customer premises interface and may not be suitable as a Terminal Station interface.	
NOTE 2: As noted above, ETS 300 012 [3] is a customer premises interface and may not be suitable as a network interface.	

Further interfaces may be implemented.

## 7 Power supply, environmental, and mechanical characteristics

### 7.1 Power supply

The power supply interface shall be in accordance with the characteristics of one or more of the secondary voltages foreseen in ETS 300 132 [5] and EN 300 019 [4].

NOTE: Some applications may require a power supply that is not covered by ETS 300 132 [5] as shown in tables 16 and 17.

**Table 12: Power Supplies - DC (not covered in ETS 300 132 [5] Part 1 and Part 2)**

Nominal voltage	Voltage range
12 V	10,8 V to 13,6 V
24 V	21,8 V to 28,1 V

**Table 13: Power Supplies - AC (not covered in ETS 300 132 [5] Part 1 and Part 2)**

For 110 V AC nominal	99 V to 121 V	60 Hz $\pm$ 2 Hz
----------------------	---------------	------------------

### 7.2 Environmental conditions

The equipment shall meet the environmental conditions set out in ETS 300 019 [4] which defines weather protected and non weather protected locations classes and test severities.

#### 7.2.1 Equipment within weather protected locations

Equipment intended for operation in temperature controlled locations or partially temperature controlled locations shall meet the requirements of ETS 300 019 [4] classes 3.1 and 3.2 respectively.

Optionally, the more stringent requirements of ETS 300 019 [4] class 3.3 (Non temperature controlled locations), 3.4 (Sites with heat trap) and 3.5 (Sheltered locations) may be applied.

#### 7.2.2 Equipment for non-weather protected locations

Equipment intended for operation in non weather protected locations shall meet the requirements of ETS 300 019 [4], class 4.1 or 4.1E.

Class 4.1 applies to many European countries and class 4.1E applies to all European countries.

Weather protected equipment conforming to classes 3.3, 3.4 and 3.5 together with an enclosure or cabinet may fulfil the requirements for operating in a non weather protected environment but this is outside the scope of the present document.

### 7.3 ElectroMagnetic Compatibility (EMC) Conditions

The system shall operate under the conditions specified in EN 300 385 [8].

---

## History

<b>Document history</b>				
V1.1.1	October 1998	Public Enquiry	PE 9909:	1998-10-30 to 1999-02-26
V1.1.1	October 1999	Vote	V 9952:	1999-10-12 to 1999-12-10