

ETSI EN 301 361-2 V1.1.1 (2000-02)

European Standard (Telecommunications series)

**Digital Enhanced Cordless Telecommunications (DECT);
Integrated Services Digital Network (ISDN);
ISDN Mobility protocol Interworking specification Profile (IMIP);
Part 2: DECT/ISDN interworking for
Global System for Mobile communications (GSM) support**



ReferenceDEN/DECT-030066

Keywordsaccess, CTM, DECT, GSM, ISDN, mobility,
profile, radio

ETSI

Postal addressF-06921 Sophia Antipolis Cedex - FRANCE

Office address650 Route des Lucioles - Sophia Antipolis
Valbonne - FRANCE
Tel.: +33 4 92 94 42 00 Fax: +33 4 93 65 47 16
Siret N° 348 623 562 00017 - NAF 742 C
Association à but non lucratif enregistrée à la
Sous-Préfecture de Grasse (06) N° 7803/88

Internetsecretariat@etsi.fr
Individual copies of this ETSI deliverable
can be downloaded from
<http://www.etsi.org>
If you find errors in the present document, send your
comment to: editor@etsi.fr

Important notice

This ETSI deliverable may be made available in more than one electronic version or in print. In any case of existing or perceived difference in contents between such versions, the reference version is the Portable Document Format (PDF). In case of dispute, the reference shall be the printing on ETSI printers of the PDF version kept on a specific network drive within ETSI Secretariat.

Copyright Notification

No part may be reproduced except as authorized by written permission.
The copyright and the foregoing restriction extend to reproduction in all media.

© European Telecommunications Standards Institute 2000.
All rights reserved.

Contents

Intellectual Property Rights	5
Foreword	5
Introduction	5
1 Scope	6
2 References	6
3 Definitions, symbols and abbreviations	7
3.1 Definitions	7
3.2 Symbols	8
3.3 Abbreviations	9
4 Feature definitions	9
4.1 Network (NWK) features	9
4.1.1 Application features	10
5 General requirements	10
5.1 Architecture	10
5.1.1 Reference configuration	10
5.1.2 Interfaces	10
5.2 Protocol model	10
5.3 Identity usage	11
5.3.1 GSM identity	11
5.3.2 GSM number	11
5.3.3 FP address	11
6 Interoperability requirements	12
6.1 General	12
6.2 NWK features	12
6.3 Application features	12
6.4 NWK feature to procedure mapping	13
6.5 Application feature to procedure mapping	14
7 Procedure descriptions	15
7.1 Connection establishment and release	15
7.1.1 NCICs connection control	15
7.1.2 Connection establishment co-ordination	15
7.1.2.1 PT initiated mobility management transaction	15
7.1.2.2 Network initiated mobility management transaction	16
7.1.3 Connection oriented data transfer co-ordination	17
7.1.4 Connection release co-ordination	18
7.2 Generic Mobility management, interworking procedures	19
7.2.1 Generic interworking procedures, network initiated transaction, explicit acknowledgement	19
7.2.1.1 FP accepts mobility management request	19
7.2.1.2 FP receives response from PP	19
7.2.1.3 FP rejects mobility management request	19
7.2.2 Generic interworking procedures, network initiated transaction, no explicit acknowledgement	20
7.2.2.1 FP accepts mobility management request	20
7.2.2.2 FP rejects mobility management request	20
7.2.3 Generic interworking procedures, PP initiated transaction, explicit acknowledgement	21
7.2.3.1 FP accepts mobility management request	21
7.2.3.2 FP receives response from network	21
7.2.3.3 FP rejects mobility management request	21
7.2.4 Generic interworking procedures, PP initiated transaction with no explicit acknowledgement	22
7.2.4.1 FP accepts mobility management request	22
7.2.4.2 FP rejects mobility management request	22
7.2.5 Identification of PP	23

7.2.6	Authentication of PP	24
7.2.7	Location registration	25
7.2.7.1	FT initiates temporary identity assignment	25
7.2.7.2	FP receives temporary reject from network.....	26
7.2.8	Network initiated ciphering	26
7.2.9	Temporary Identity Assignment.....	27
7.2.10	Linked Temporary Identity Assignment	27
7.2.11	Detach.....	28
7.3	Call control procedures	28
7.3.1	General.....	28
7.3.2	Outgoing call	28
7.3.3	Incoming call	32
7.3.4	Call progress information transfer	35
7.3.5	Call release	36
7.3.5.1	Network initiated release.....	36
7.3.5.2	PT initiated release.....	37
7.3.5.3	Other release cases	37
7.3.6	Keypad information transfer	38
7.4	Other interworking procedures	38
7.4.1	Interaction in-between MM transactions.....	38
7.4.2	Interactions between MM- and CC- transactions.....	39
7.4.3	Other interactions between local and interworked procedures.....	39
7.4.4	Error handling.....	39
8	Message mappings	39
8.1	General	39
8.2	Mobility management message/component mapping	40
8.2.1	General.....	40
8.2.1a	MM component to DECT message.....	40
8.2.2	DECT message to MM component.....	40
8.3	Call control message mapping.....	41
8.3.1	General.....	41
8.3.1a	DSS1 message to DECT message.....	41
8.3.2	DECT message to DSS1 message.....	41
8.4	Information element/parameter mapping.....	42
8.4.1	General.....	42
8.4.1a	GSM information element/parameter to DECT information element	42
8.4.1.1	General/transparent mapping	42
8.4.1.2	<_componentType>+ <_operation> - << message type>>	43
8.4.1.3	<_gSMIdentityType> - <<identity type>>	43
8.4.1.4	<_invokeIdentifier> - << transaction identifier>>	43
8.4.2	DECT information element to GSM information element/parameter	44
8.4.2.1	General/transparent mapping	44
8.4.2.2	Fixed identity + location area - _gSMLocationAreaIdentity	44
8.4.2.3	Message type - _componentType+ _operation.....	45
8.4.2.4	Transaction identifier - _invokeIdentifier.....	45
	Bibliography	46
	History	47

Intellectual Property Rights

IPRs essential or potentially essential to the present document may have been declared to ETSI. The information pertaining to these essential IPRs, if any, is publicly available for **ETSI members and non-members**, and can be found in SR 000 314: "*Intellectual Property Rights (IPRs); Essential, or potentially Essential, IPRs notified to ETSI in respect of ETSI standards*", which is available from the ETSI Secretariat. Latest updates are available on the ETSI Web server (<http://www.etsi.org/ipr>).

Pursuant to the ETSI IPR Policy, no investigation, including IPR searches, has been carried out by ETSI. No guarantee can be given as to the existence of other IPRs not referenced in SR 000 314 (or the updates on the ETSI Web server) which are, or may be, or may become, essential to the present document.

Foreword

This European Standard (Telecommunications series) has been produced by ETSI Project Digital Enhanced Cordless Telecommunications (DECT).

The present document is part 2 of a multi-part standard covering the ISDN Mobility protocol Interworking specification Profile (IMIP), as identified below:

Part 1: "DECT/ISDN interworking for Cordless Terminal Mobility (CTM) support";

Part 2: "**DECT/ISDN interworking for Global System for Mobile communications (GSM) support**".

National transposition dates	
Date of adoption of this EN:	7 January 2000
Date of latest announcement of this EN (doa):	30 April 2000
Date of latest publication of new National Standard or endorsement of this EN (dop/e):	31 October 2000
Date of withdrawal of any conflicting National Standard (dow):	31 October 2000

Introduction

The present document defines a profile for interworking between a DECT system and an Integrated Services Digital Network (ISDN) using the enhanced Digital Subscriber Signalling No. 1 (DSS1) protocol defined in EN 301 144-1 [13]. This ISDN protocol enables cordless terminals to have access to an ISDN infrastructure.

Part one defines the DECT/DSS1+ interworking for the CTM support.

Part two considers the DECT/DSS1+ interworking for the GSM support.

The present document specifies how DSS1+ procedures and information are mapped over the DECT air interface, and how they are provided and used by the DECT Fixed Part.

1 Scope

The present document specifies a set of technical requirements for Digital Enhanced Cordless Telecommunications (DECT) Fixed Parts (FP) supporting connection, via an ISDN interface, to a network supporting terminal mobility.

The present document covers the requirements necessary for the support of Cordless Terminal Mobility (CTM) (Part 1) and for the support of the DECT access to GSM via ISDN interfaces (Part 2).

The present document specifies the interworking procedures between the Digital Enhanced Cordless Telecommunications (DECT) air interface and the mobility management protocols defined for Integrated Services Digital Network (ISDN) interfaces.

2 References

The following documents contain provisions which, through reference in this text, constitute provisions of the present document.

- References are either specific (identified by date of publication, edition number, version number, etc.) or non-specific.
- For a specific reference, subsequent revisions do not apply.
- For a non-specific reference, the latest version applies.
- A non-specific reference to an ETS shall also be taken to refer to later versions published as an EN with the same number.

- [1] ETS 300 011: "Integrated Services Digital Network (ISDN); Primary rate user-network interface; Layer 1 specification and test principles".
- [2] ETS 300 012: "Integrated Services Digital Network (ISDN); Basic user-network interface; Layer 1 specification and test principles".
- [3] EN 300 175-2: "Digital Enhanced Cordless Telecommunications (DECT); Common Interface (CI); Part 2: Physical Layer (PHL)".
- [4] EN 300 175-3: "Digital Enhanced Cordless Telecommunications (DECT); Common Interface (CI); Part 3: Medium Access Control (MAC) layer".
- [5] EN 300 175-4: "Digital Enhanced Cordless Telecommunications (DECT); Common Interface (CI); Part 4: Data Link Control (DLC) layer".
- [6] EN 300 175-5: "Digital Enhanced Cordless Telecommunications (DECT); Common Interface (CI); Part 5: Network (NWK) layer".
- [7] ETS 300 402: "Integrated Services Digital Network (ISDN); Digital Subscriber Signalling System No. one (DSS1) protocol; Data link layer".
- [8] EN 300 403-1: "Integrated Services Digital Network (ISDN); Digital Subscriber Signalling System No. one (DSS1) protocol; Signalling network layer for circuit-mode basic call control; Part 1: Protocol specification [ITU-T Recommendation Q.931 (1993), modified]".
- [9] ETS 300 434-2: "Digital Enhanced Cordless Telecommunications (DECT); Integrated Services Digital Network (ISDN); DECT/ISDN interworking for end system configuration; Part 2: Access profile".
- [10] EN 300 444: "Digital Enhanced Cordless Telecommunications (DECT); Generic Access Profile (GAP)".

- [11] ETS 300 788: "Digital Enhanced Cordless Telecommunications (DECT); Global System for Mobile communications (GSM); Integrated Services Digital Network (ISDN); DECT access to GSM via ISDN; Functional capabilities and information flows".
- [12] EN 301 061-1: "Integrated Services Digital Network (ISDN); Digital Subscriber Signalling System No. one (DSS1) protocol; Generic functional protocol for the support of supplementary services at the "b" service entry point for Virtual Private Network (VPN) applications; Part 1: Protocol specification".
- [13] EN 301 144-1: "Integrated Services Digital Network (ISDN); Digital Subscriber Signalling System No. one (DSS1) and Signalling System No. 7 (SS7); Signalling application for the mobility management service on the alpha interface; Part 1: Protocol specification".
- [14] CCITT Recommendation I.411 (1988): "ISDN user-network interfaces - Reference configurations".
- [15] CCITT Recommendation X.219 (1988): "Remote operations: Model, notation and service definition".
- [16] ISO/IEC 9646-7 (1995): "Information technology - Open Systems Interconnection - Conformance testing methodology and framework - Part 7: Implementation Conformance Statements".
- [17] EN 301 361-1: "Digital Enhanced Cordless Telecommunications (DECT); Integrated Services Digital Network (ISDN); ISDN Mobility protocol Interworking specification Profile (IMIP); Part 1: DECT/ISDN interworking for Cordless Terminal Mobility (CTM) support".
- [18] ETS 300 434-1: "Digital Enhanced Cordless Telecommunications (DECT); Integrated Services Digital Network (ISDN); DECT/ISDN interworking for end system configuration; Part 1: Interworking specification".

3 Definitions, symbols and abbreviations

3.1 Definitions

For the purposes of the present document, the terms and definitions given in GAP [10] and the following apply:

DECT access network: physical entity that contains all of the elements of a DECT Fixed Part (FP) and that is attached to a GSM MSC

NOTE 1: A DECT access network provides a transparent access to the services of the GSM PLMN. This does however not exclude that it may in addition provide services and switching capabilities to its own users.

DECT Fixed Part (FP): physical grouping that contains all of the elements in the DECT network between the local network and the DECT air interface

NOTE 2: A DECT FP contains the logical elements of at least one fixed radio termination, plus additional implementation specific elements.

DECT location area: domain in which a DECT PP may receive and/or make calls as a result of a single location registration in the DECT access network

GSM location area: domain in which a DECT PP may receive and/or make calls as a result of a single location updating in the GSM network

NOTE 3: A GSM location area may cover more than one DECT location area.

GSM service provider: administration which offers global mobile telecommunication services to its subscribers

GSM services: services which are offered to the subscriber/user by a GSM Service Provider and which are defined by the appropriate GSM specifications

location registration: process whereby the position of a PP is determined to the level of one location area, and this position is updated in the network

location updating: process whereby the position of a PP is determined to the level of one location area, and this position is updated in the network

NOTE 4: DECT and GSM respectively use the terms location registration and location updating for actually similar processes.

MSC area: MSC area is the part of the network covered by an MSC. An MSC area may consist of one or several GSM location areas. An MSC area may also consist of one or several Base Station Controller (BSC) areas and/or one or several DECT location areas

network: totality of GSM and DECT access network elements through which the GSM service provider provides its services to the served user

Public Land Mobile Network (PLMN): PLMN is established and operated by an administration or for the specific purpose of providing land mobile telecommunication services to the public. A PLMN may be regarded as an extension of a network (e.g. ISDN); it is a collection of MSC areas within a common numbering plan (e.g. same National Destination Code) and a common routing plan. The MSCs are the functional interfaces between the fixed networks and a PLMN for call set-up. Functionally the PLMNs may be regarded as independent telecommunication entities even though different PLMNs may be interconnected through the Integrated Services Digital Network/Private Integrated Services Network (ISDN/PISN) and Packet Data Networks (PDNs) for forwarding of calls or network information. A similar type of interconnection may exist for the interaction between the MSCs of one PLMN

served user: user of a DECT PP who has a subscription with the GSM service provider. The DECT PP accepts the GSM Subscriber Identification Module (SIM) and optionally the DECT Authentication Module (DAM) with a GSM application

NOTE 5: For the purpose of the present document no distinction is made between the served user and its associated DECT PP.

3.2 Symbols

The symbols defined in this subclause are applied for procedures, features, services in the present document if not explicitly otherwise stated. The interpretation of status columns in all tables is as follows:

M	for mandatory to support (provision mandatory, process mandatory)
O	for optional to support (provision optional, process mandatory)
I	for out-of-scope (provision optional, process optional) not subject for testing
C	for conditional to support (process mandatory)
N/A	for not-applicable (in the given context the specification makes it impossible to use this capability)
X	ignore parameter or FP creates parameter

Provision mandatory, process mandatory means that the indicated feature, service or procedure shall be implemented as described in the present document, and may be subject to testing.

Provision optional, process mandatory means that the indicated feature, service or procedure may be implemented, and if implemented, the feature, service or procedure shall be implemented as described in the present document, and may be subject to testing.

NOTE: The used notation is based on the notation proposed in ISO/IEC 9646-7 [16].

3.3 Abbreviations

For the purposes of the present document, the abbreviations given in GAP [10] and the following apply:

B	Business (environment)
BRA	Basic Rate Access
BSC	Base Station Controller
CC	Call Control
CI	Common Interface
DAM	DECT Authentication Module
DECT	Digital Enhanced Cordless Telecommunications
DLC	Data Link Control layer
DSS1	Digital Subscriber Signalling System No. 1
DTMF	Dual Tone Multi-Frequency
FP	Fixed Part
FT	Fixed radio Termination
GAP	Generic Access Profile
GSM	Global System for Mobile communications
IAP	ISDN Access Profile
IE	Information Element
IMIP	ISDN Mobility protocol Interworking specification Profile
IMSI	International Mobile Station Identity
IPEI	International Portable Equipment Identity
IPUI	International Portable User Identity
ISDN	Integrated Services Digital Network
LAL	Location Area Level
LE	Local Exchange
MM	Mobility Management
MSC	Mobile Switching Centre
NCIC	Network Call Independent Connection
NT	Network Termination
NWK	NetWorK
P	Public (environment)
PHL	PHysical Layer
PISN	Private Integrated Services Network
PLMN	Public Land Mobile Network
PP	Portable Part
PRA	Primary Rate Access
PT	Portable radio Termination
R	Residential (environment)
SIM	Subscriber Identification Module
TMSI	Temporary Mobile Station Identity
TPUI	Temporary Portable User Identity

4 Feature definitions

For the purposes of the present document, the feature definitions in the following subclauses apply.

The number given in parentheses after the name of a feature is the item number used in the tables of the present document.

4.1 Network (NWK) features

See EN 300 444 [10].

4.1.1 Application features

The application features defined in the present document concern the interworking of the corresponding network layer features. Hence no new definitions are required.

5 General requirements

5.1 Architecture

5.1.1 Reference configuration

Reference configurations describe functional groupings by using reference points, as described in CCITT Recommendation I.411 for ISDN [14]. For GSM the reference configurations are shown in the alpha interface specification [13].

An overview of standard ISDN and GSM specific reference configurations is shown in figure 1.

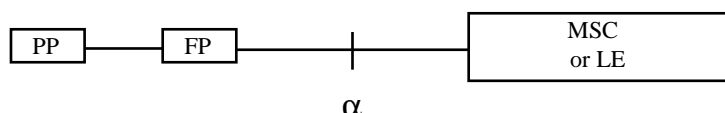

Figure 1: Standard ISDN and GSM specific reference configuration

5.1.2 Interfaces

This interworking profile is based on the alpha interface standard [13], which applies to GSM networks.

The present document covers both basic rate and primary rate access (BRA, PRA). Point to multi-point as well as point to point configurations are applicable.

5.2 Protocol model

The following figure provides an overview of the protocol model used to describe the protocol interworking within the FT. The present document is mainly concerned with the interworking between DECT mobility management procedures (invoked by means of messages and information elements at the air interface) and the MM components on the alpha interface (invoked by means of Remote Operations).

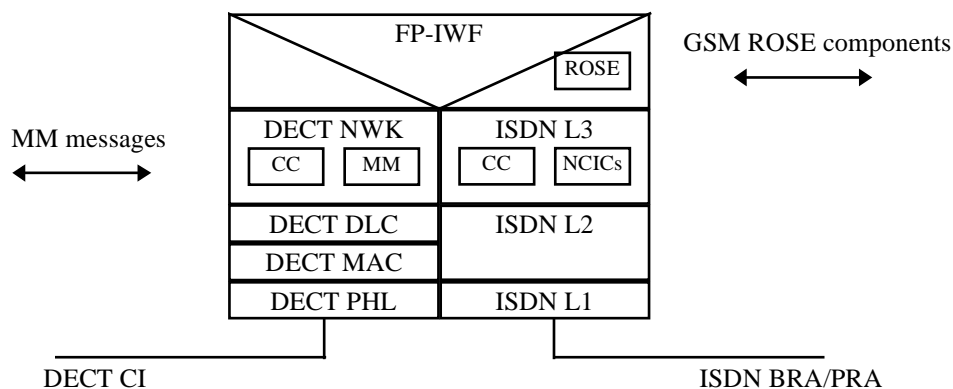

Figure 2: Protocol model

Table 1: Description of DECT and ISDN layers

Layers	DECT	ISDN
L4 to 6		EN 301 144-1 (GSM signalling application) [13] X.219 (ROSE) [15]
L3	EN 300 175-5 (NWK) [6]	ETS 300 403-1 (CC) [8] EN 301 061-1 (NCICs) [12]
L2	EN 300 175-4 (DLC) [5] EN 300 175-3 (MAC) [4]	ETS 300 402 [7]
L1	EN 300 175-2 [3]	ETS 300 011 (PRA) [1] ETS 300 012 (BRA) [2]

5.3 Identity usage

5.3.1 GSM identity

At the alpha interface, the GSM identity is used to uniquely identify a GSM user. At the air interface however, the DECT PP- identity is used to identify the user. The FP provides the mapping between the PP- identity and the GSM-Identity.

The present document assumes the following:

- 1) there is a one to one relation between the GSM identity (IMSI, TMSI) and the PP- identity (IPUI or TPUI);
- 2) there are no restrictions concerning the PP identity to be used at the air interface.

NOTE 1: The FT need not reject a PP- initiated request containing an identity type or length that may not be supported by the GSM network.

NOTE 2: The use of non-GSM identities (e.g. residential identities) for roaming to/from the residential area is outside the scope of the present document.

5.3.2 GSM number

The GSM number is the E.164 number that is dialled to call a GSM user.

In case CLIP is subscribed to, the network may provide the GSM number within the <<calling party number>> to the called user (GSM Network-> FP).

5.3.3 FP address

The FP-address is a globally unique E.164 number and corresponds to the address of the FP via which the PP is connected to the MSC or LE. The FP-address is required only in case of a point to multi-point configuration.

In case of an incoming call, the FP-address is conveyed inside the <<called party number>> (GSM Network -> FP).

In case of an outgoing call, the FP-address is transferred within a <<calling party number>> (FP -> GSM Network).

6 Interoperability requirements

6.1 General

In order to achieve interoperability, this clause defines the status of features and the associated interworking requirements in a similar manner as done in EN 300 444 (GAP) [10].

The interworking requirements specified in the present document concern the application layer and the network layer.

The application layer requirements are specified in the present document. The ISDN network layer requirements are fully specified in [13]. For the DECT network layer, all FT requirements specified in GAP [10] apply unless explicitly stated otherwise. This means that only additions/modifications to GAP [10] are included in this clause.

6.2 NWK features

All requirements specified in subclause 6.2 of EN 300 444 [10] apply with the following modifications:

Table 2: NWK features status

Feature supported					
Item no.	Name of feature	GAP Ref. [10]	Status		
			FT		
			R	B	P
N.9	Authentication of portable	4.1	M	M	M
N.11	Location registration	4.1	M	M	M
N.13	Identification of portable	4.1	M	M	M
N.17	Network initiated ciphering	4.1	M	M	M
IMIP-N.1	Temporary identity assignment	-	M	M	M
IMIP-N.2	Linked Temporary identity assignment	-	M	M	M
IMIP-N.3	Detach	-	M	M	M
NOTE: The GSM service should be uniform across different application areas. As a result, the status of features is the same in all environments.					

6.3 Application features

The references of the following table are to the present document.

Table 3: Application features status

Feature supported					
Item no.	Name of feature	Ref.	Status		
			FT		
			R	B	P
IMIP-A.1	General	4.1.1	M	M	M
IMIP-A.2	Identification of portable	4.1.1	M	M	M
IMIP-A.4	Authentication of portable	4.1.1	M	M	M
IMIP-A.5	Location registration	4.1.1	M	M	M
IMIP-A.6	Location cancellation	4.1.1	M	M	M
IMIP-A.11	Network initiated ciphering	4.1.1	M	M	M
IMIP-A.13	Outgoing call	4.1.1	M	M	M
IMIP-A.14	Incoming call	4.1.1	M	M	M
IMIP-A.15	Supplementary service activation	4.1.1	O	O	O
IMIP-A.16	DTMF generation	4.1.1	O	O	O
IMIP-A.17	Temporary identity assignment	-	M	M	M
IMIP-A.18	Linked Temporary identity assignment	-	M	M	M
IMIP-A.19	Detach	-	M	M	M

6.4 NWK feature to procedure mapping

All requirements specified in subclause 6.7 of the EN 300 444 [10] apply with the following modifications:

Table 4: NWK feature to procedure mapping

Feature/Procedure mapping						
Item No	Name of feature	Procedure	GAP Ref. [10]	Status		
				R	B	P
N° 11	Location registration			M	M	M
		Location update	8.29	M	M	M
N° 1	Outgoing call			M	M	M
		Overlap sending	8.3	M	M	M
		Outgoing call proceeding	8.4	M	M	M
		Outgoing call confirmation	8.5	M	M	M
		Flexible U- plane connection		O	O	O
NOTE: For the listed features, only those procedures are specified for which the requirements are different as compared to GAP [10]; for feature location registration, the requirements for the location registration procedure are as specified in GAP [10].						

6.5 Application feature to procedure mapping

All references specified in table 5 are to the present document.

Table 5: Application feature to procedure mapping

Feature/Procedure mapping				Status		
Item No	Name of feature	Procedure	References	FT		
				R	B	P
	General			M	M	M
		Connection establishment and release	7.1	M	M	M
		Generic mobility management interworking procedures	7.2 - 7.2.4	M	M	M
		Generic message mapping	8 - 8.2.2	M	M	M
		Generic information element	8.4	M	M	M
	Identification of portable part			O	O	O
		Identification of PP	7.2.5	M	M	M
	Authentication of portable part			M	M	M
		Authentication of PP	7.2.6	M	M	M
	Location registration			M	M	M
		Location registration	7.2.7	M	M	M
	Location cancellation			M	M	M
		Location cancellation	7.4.3	M	M	M
	Network initiated ciphering			M	M	M
		Cipher switching initiated by network	7.2.8	M	M	M
	Temporary identity assignment			M	M	M
		Assign temporary identity	7.2.9	M	M	M
	Linked Temporary identity assignment			M	M	M
		Linked Assign temporary identity	7.2.10	M	M	M
	Detach			M	M	M
		Detach	7.2.11	M	M	M
	Outgoing call			M	M	M
		Outgoing call	7.3.2	M	M	M
		Call progress information transfer	7.3.4	O	O	O
		Call release	7.3.5	M	M	M
	Incoming call			M	M	M
		Incoming call	7.3.3	M	M	M
		Call progress information transfer	7.3.4	O	O	O
		Call release	7.3.5	M	M	M
	Supplementary service activation			O	O	O
		Keypad information transfer	7.3.6	M	M	M
	DTMF generation			O	O	O
		Keypad information transfer	7.3.6	M	M	M

NOTE: In order to simplify the specification, a feature "General" has been introduced. This is used to specify the status of clauses specifying interworking requirements/principles that are not related to a specific feature.

7 Procedure descriptions

This clause specifies the interworking requirements for the mobility management procedures as required for the DECT access to GSM. Furthermore, this clause specifies additions/modifications to the interworking requirements for call control as specified in the ISDN Access Profile [9].

NOTE: The interworking requirements may include requirements concerning the interaction between interworking and non-interworking procedures.

7.1 Connection establishment and release

This subclause describes the co-ordination between the radio connection establishment/release and the establishment/release of the mobility management transport mechanism used at the alpha interface.

There are requirements concerning co-ordination during connection establishment, but not for connection release.

7.1.1 NCICs connection control

The NCICs connection establishment and release procedures are described in [13]. The radio link establishment and release procedures are specified in [10], subclauses 8.35 to 8.39.

There is co-ordination between NCICs and radio link control procedures during connection establishment and data transfer, as specified in the following.

7.1.2 Connection establishment co-ordination

7.1.2.1 PT initiated mobility management transaction

In case the FT receives a PT- initiated mobility management request concerning a PT for which an NCICs connection already exists, it shall use this connection to transfer the mobility management request.

In case the FT receives a PT- initiated mobility management request concerning a PT for which no NCICs connection exists, the FT shall initiate the establishment of such a NCICS connection.

NOTE: Across the alpha interface the NCICs connection establishment request shall include a GSM Identity. In case the PT- initiated transaction request does not include a <<PP- identity>>, the FT may need to derive or retrieve the IPUI.

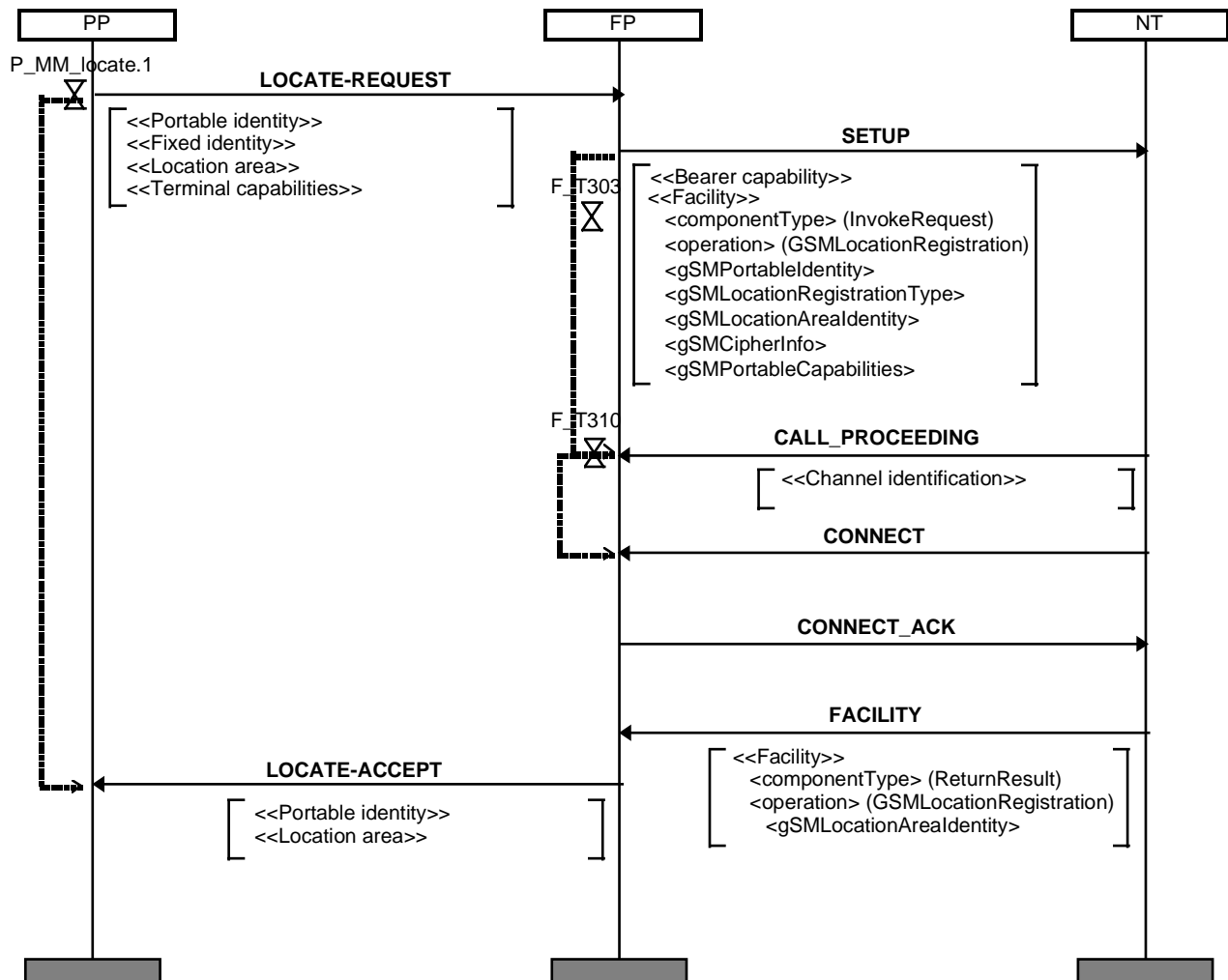

NOTE: This is the normal terminal initiated NCICs connection establishment. The Location Registration operation is given as an example.

Figure 3: NCIC terminal initiated connection establishment

7.1.2.2 Network initiated mobility management transaction

The FT need not delay acceptance of the NCICs- connection establishment request until radio connection establishment has been completed successfully and/or a response has been received from the PT for the associated MM- transaction.

The FT shall not reject an NCICs connection establishment request concerning a PT for which another NCICs connection has already been established.

NOTE: Although in most cases the network re-uses an existing NCICs connection for the concerned PT, this may not always be possible. In the latter case, multiple simultaneous NCICs connections may be used for a PT.

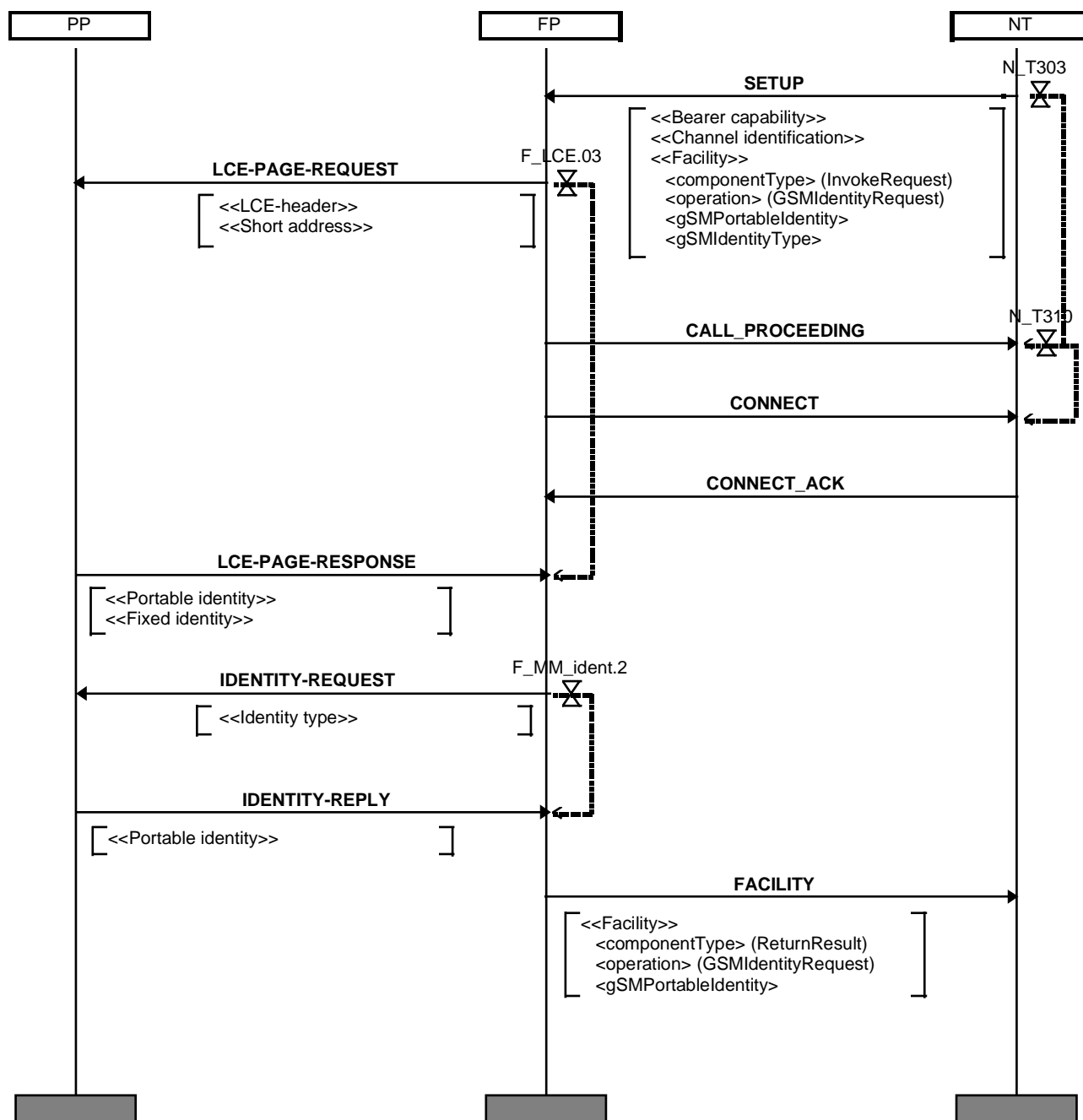

NOTE: This is the normal network initiated NCICs connection establishment. IdentityRequest operation is given as an example.

Figure 4: NCIC network initiated connection establishment

7.1.3 Connection oriented data transfer co-ordination

In case more than one NCICs connection exists for the connected PT, the FT shall apply the following rules:

- a return result/error shall be transferred across the same NCICs connection as used to transfer the invoke;
- a request concerning an embedded procedure, e.g. authentication of network, shall be returned across the same NCICs connection as used to transfer the initial request that triggered the embedded procedure (e.g. terminate access rights, network initiated).

NOTE: Within the GSM network, more than one node may initiate mobility management transactions. Due to this, the GSM network may be unable to ensure that only one NCICs connection is established per PT.

7.1.4 Connection release co-ordination

The FT need not co-ordinate release of the radio link connection and the NCICs connection as illustrated in the following sequence diagrams.

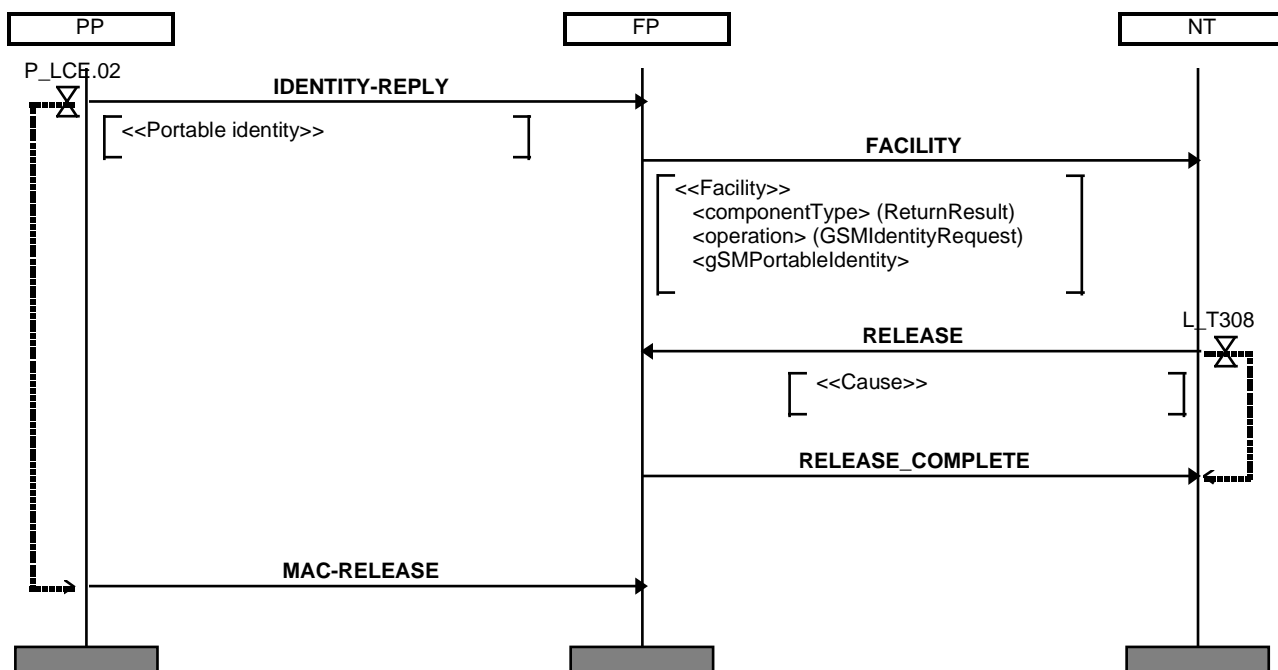

NOTE: Identity request is given as an example. Partial release applies at the air interface.

Figure 5: NCIC network initiated call release

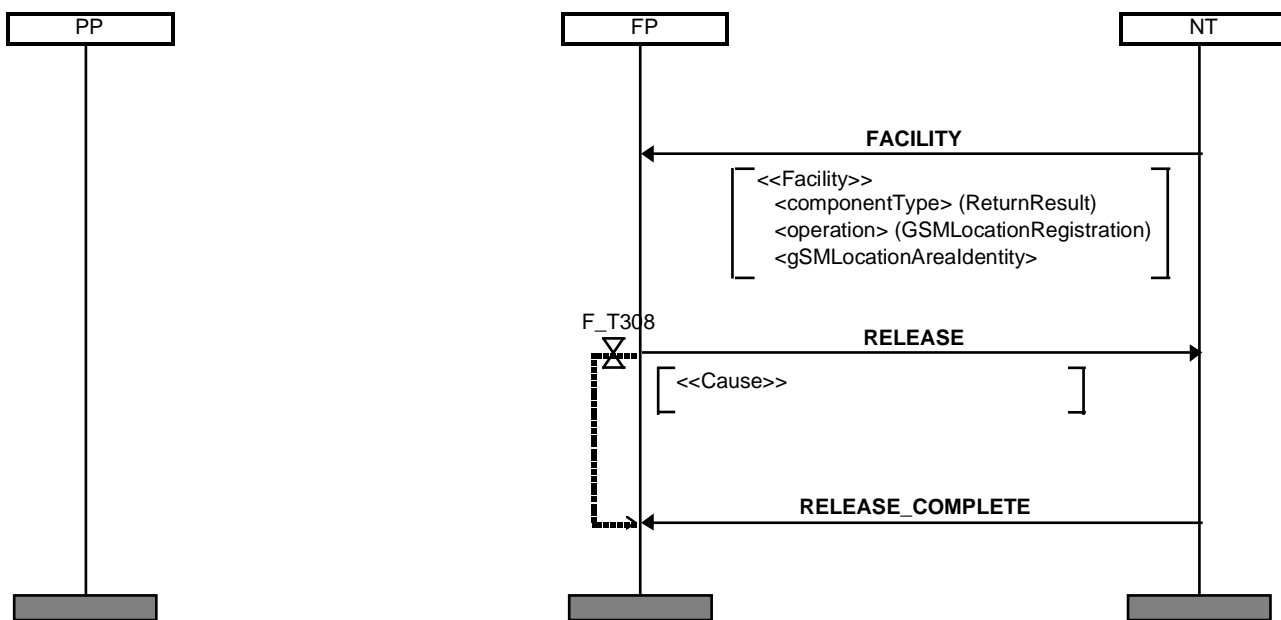

NOTE: Terminal initiated MM-signalling connection release. Only used in exceptional cases e.g. maintenance action.

Figure 6: NCIC terminal initiated call release

7.2 Generic Mobility management, interworking procedures

The following table provides an overview of the mobility management procedures and their status in the DECT access to GSM as specified in [13].

Table 6: Overview of the mobility management procedures

Procedure	DECT messages	MM operation	Note
Identification of PP	IDENTITY-REQUEST IDENTITY-REPLY	gSMIdentityRequest	
Authentication of PP	AUTHENTICATION-REQUEST AUTHENTICATION-REPLY AUTHENTICATION-REJECT	gSMTerminalAuthentication	
Location registration	LOCATE-REQUEST LOCATE-ACCEPT LOCATE-REJECT TEMPORARY-IDENTITY-ASSIGN-ACK TEMPORARY-IDENTITY-ASSIGN-REJECT	gSMLocationRegistration	1
Cipher switching initiated by network	CIPHER-REQUEST CIPHER-REJECT (DL_ENCRYPT.IND)	gSMCiphering	2
Temporary Identity assignment	TEMPORARY-IDENTITY-ASSIGN TEMPORARY-IDENTITY-ASSIGN-ACK TEMPORARY-IDENTITY-ASSIGN-REJ	gSMAssignIdentity	
Linked Temporary Identity assignment	TEMPORARY-IDENTITY-ASSIGN TEMPORARY-IDENTITY-ASSIGN-ACK TEMPORARY-IDENTITY-ASSIGN-REJ	gSMLinkedAssignIdentity	
NOTE 1: This procedure includes an additional information transfer related to the assignment of a temporary identity.			
NOTE 2: For this procedure the return result is triggered by a local primitive rather than by a network layer message received across air interface.			

The following subclauses only describe the generic interworking procedures. Additional requirements, if applicable, are included in the section providing the interworking procedure specific for the corresponding MM- procedure.

The feature specific sections also include message interworking specifications, for which the general principles are described in subclause 8.1.

7.2.1 Generic interworking procedures, network initiated transaction, explicit acknowledgement

7.2.1.1 FP accepts mobility management request

Upon reception of an MM invoke component concerning a network initiated mobility management request, the FT shall initiate the corresponding mobility management transaction towards the PT. This involves the starting of the applicable FP- timer as described in [6] and the interworking of the message as described within the applicable feature specific procedure description.

7.2.1.2 FP receives response from PP

Upon reception of the response, either positive or negative, the FP shall stop the applicable timer as described in [6] and interwork the received message to the corresponding MM return result or return error component as specified in clause 8, message mappings.

7.2.1.3 FP rejects mobility management request

In case the FP rejects the network initiated mobility management request, it shall send an MM return error component towards the network, including an error value indicating the reason of rejection.

NOTE: The FP may reject the network initiated mobility management request in case of resource contention, no response to paging, expiry of the applicable DECT timer, loss of the radio link connection.

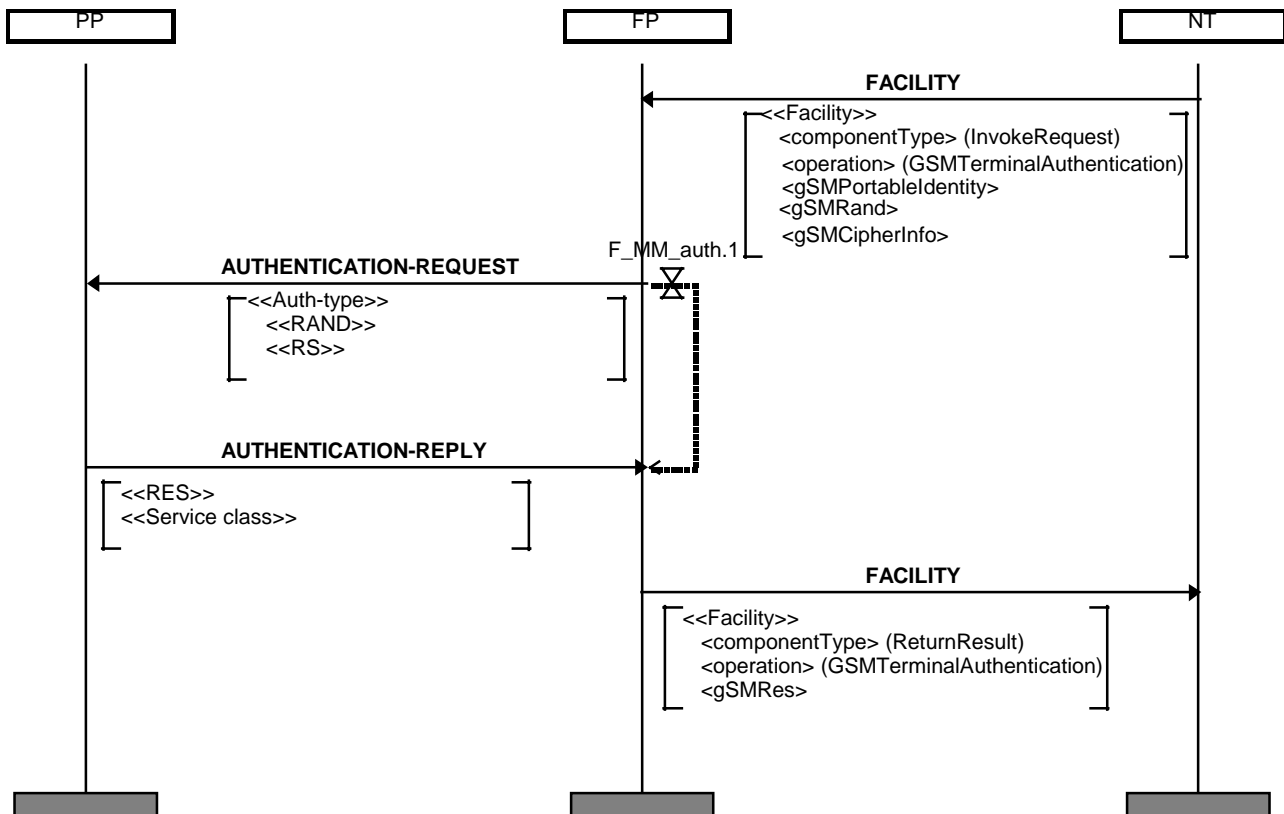

NOTE: Terminal authentication is shown as an example. FACILITY is shown as a possible NCICs data transport message.

Figure 7: Network initiated MM transaction with explicit acknowledgement

7.2.2 Generic interworking procedures, network initiated transaction, no explicit acknowledgement

7.2.2.1 FP accepts mobility management request

Upon reception of an MM invoke component concerning a network initiated mobility management request, the FP shall initiate the corresponding mobility management transaction towards the PP. This involves the interworking of the message as specified within the applicable feature specific procedure description.

In response to the network initiated procedure, the PP may start a mobility management procedure. This is considered as another transaction/operation e.g. the location registration following the location update procedure.

7.2.2.2 FP rejects mobility management request

In case the FP rejects the network initiated mobility management request, it shall send an MM return error component towards the network, including an error value indicating the reason of rejection.

NOTE: The FP may reject the network initiated mobility management request in case of resource contention, etc.

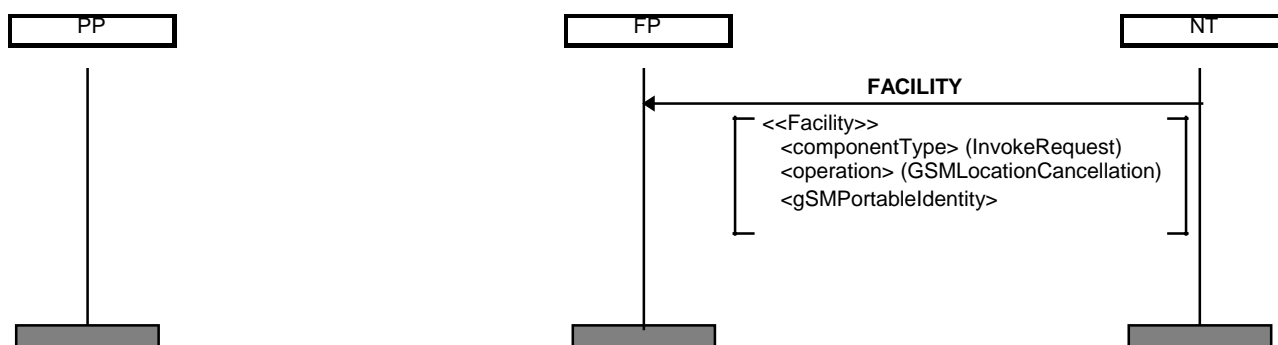

NOTE: Location Cancellation is shown as an example. FACILITY is shown as possible NCICs transport message.

Figure 8: Network initiated MM transaction with no explicit acknowledgement

7.2.3 Generic interworking procedures, PP initiated transaction, explicit acknowledgement

7.2.3.1 FP accepts mobility management request

Upon reception of a DECT mobility management message, the FP shall initiate the corresponding MM invoke component towards the network. This involves the interworking of the message as described in clause 8, message mappings.

7.2.3.2 FP receives response from network

Upon reception of the MM return response or return error component from the network, the FP shall interwork the received component to the corresponding DECT mobility management message as specified in clause 8, message mappings.

7.2.3.3 FP rejects mobility management request

In case the FP rejects the PP- initiated mobility management request, it shall apply the reject procedure as defined in [6] for the concerned DECT mobility management procedure.

NOTE: The FP may reject the network initiated mobility management request e.g. in case of resource contention, NCICs connection (establishment) failure.

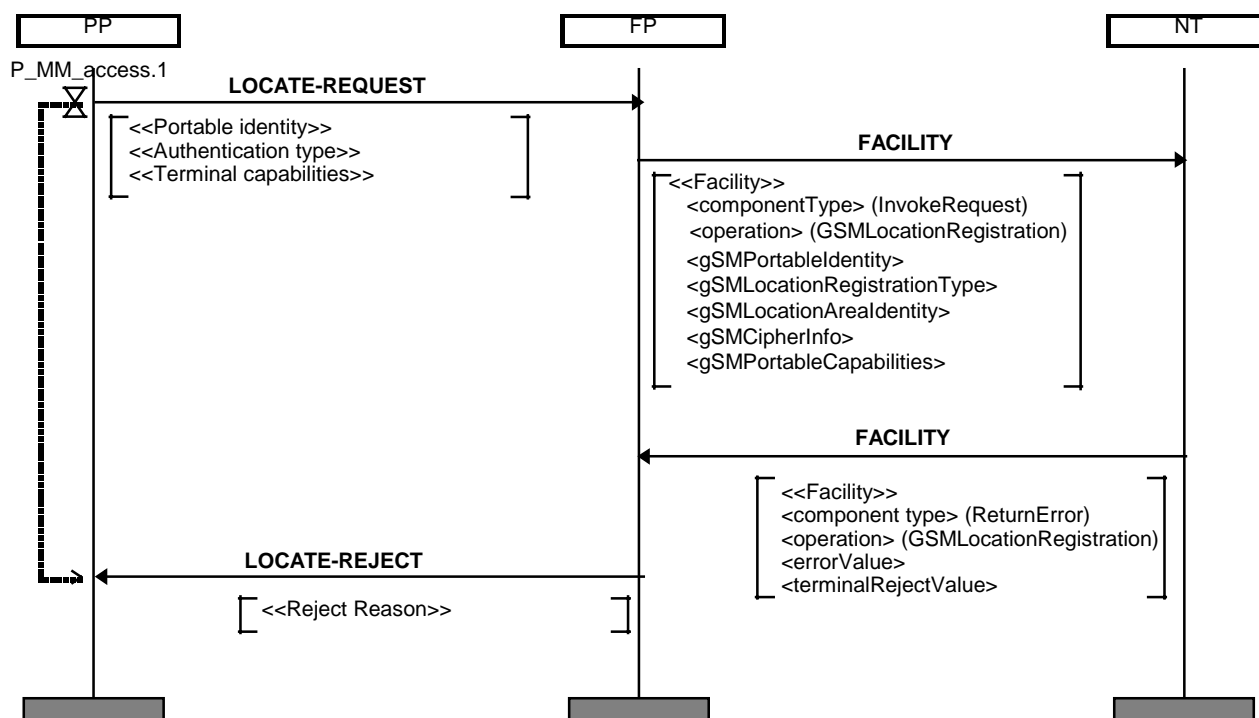

NOTE: Location Registration is shown as an example. FACILITY is shown as possible NCICs data transport message.

Figure 9: PT initiated MM transaction with explicit acknowledgement

7.2.4 Generic interworking procedures, PP initiated transaction with no explicit acknowledgement

7.2.4.1 FP accepts mobility management request

Upon reception of a DECT mobility management message, the FP shall initiate the corresponding MM invoke component towards the network. This involves the interworking of the message as described within the applicable feature specific procedure description.

In response to the PP- initiated procedure, the network may start a mobility management procedure. This may be considered as part of the same transaction.

NOTE: At the alpha interface the network initiated procedure is not considered to be part of the same operation.

7.2.4.2 FP rejects mobility management request

In case the FT rejects the PT- initiated mobility management request, it shall apply the reject procedure if defined in [6] for the concerned DECT mobility management procedure.

NOTE: The FP may reject the network initiated mobility management request e.g. in case of resource contention, NCICs connection (establishment) failure.

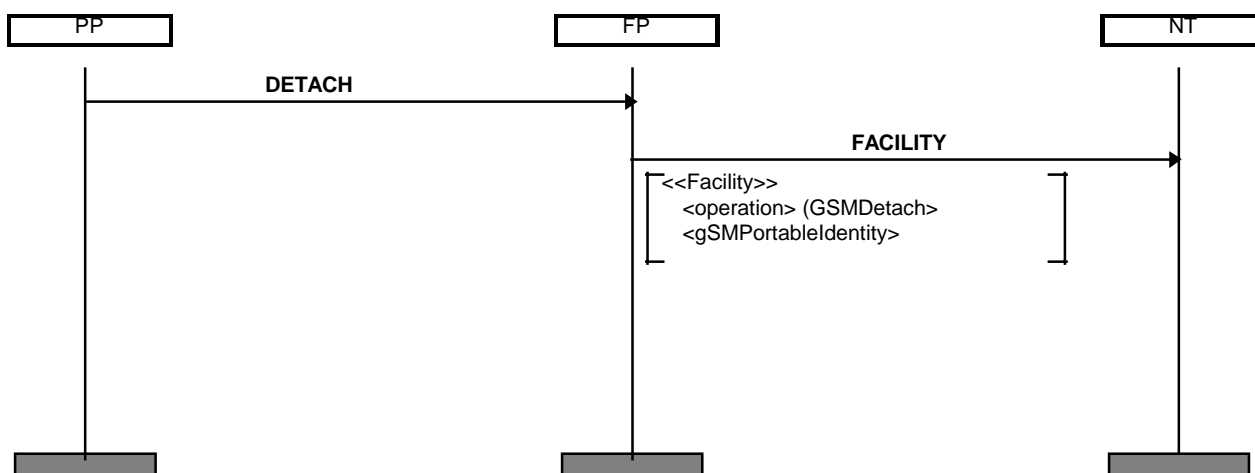

NOTE: Detach is shown as an example. FACILITY is shown as possible NCICs data transport message.

Figure 10: PT initiated MM transaction with no explicit acknowledgement

7.2.5 Identification of PP

The network may use this procedure to retrieve the PP's IPUI or TPUI (IMSI or TMSI) as defined in [13], subclause 9.3.8.

In addition to the requirements specified in 7.2.1, generic interworking procedures for network initiated mobility management transactions with explicit acknowledgement, the following applies.

In case the PT does not include an identity within the {IDENTITY-RESULT}, the FT shall map this to an MM return error component. The FT shall include an appropriate indication (identityNotAvailable or portableIdentityUnknown) in the errorValue parameter.

Table 7: Mapping of IdentityRequest Invoke - IDENTITY-REQUEST

Item No	MM component	DECT message	Ref.	Map status	Note
1	IdentityRequest Invoke	IDENTITY-REQUEST			
1		protocol discriminator		X	
2	invokelIdentifier	transaction identifier		M	
3	componentType operation	message type		M	
4	gSMIdentityType	identity type		M	
5	gSMPortableIdentity			X	note 1

NOTE 1: The NT provides the gSMPortableIdentity in case the component is transferred within an NCICs connection establishment message.

NOTE 2: Identity requests other than the network initiated request for a PP- identity (IMSI/TMSI) are outside the scope of the present document.

Table 8: Mapping of IDENTITY-REPLY - IdentityRequest Return Result

Item No	DECT message IDENTITY-REPLY	MM component IdentityRequest Return Result	Ref.	Map status	Note
1	protocol discriminator			X	
2	transaction identifier	invokelIdentifier		M	
3	message type	componentType operation		M	
4	portable identity	gSMPortableIdentity		M	note 1
NOTE 1: This interworking applies only in case the case the <<portable identity>> is included in the {IDENTITY-REPLY} message.					
NOTE 2: Identity requests other than the network initiated request for a PP- identity (IMSI/TMSI) are outside the scope of the present document.					

Table 9: Mapping of IDENTITY-REPLY - IdentityRequest Return Error

Item No	DECT message IDENTITY-REPLY	MM component IdentityRequest Return Error	Ref.	Map status	Note
1	protocol discriminator			X	
2	transaction identifier	invokelIdentifier		M	
3	message type	componentType operation		M	
4		errorValue		X	
5	reject reason	RejectReason		O	
NOTE: This interworking applies in case no identity is included in the {IDENTITY-REPLY} message.					

7.2.6 Authentication of PP

The network may use this procedure to authenticate the PP as defined in [13], subclause 9.3.2.

There are no requirements in addition to the ones specified in 7.2.1, generic interworking procedures for network initiated mobility management transactions with explicit acknowledgement.

Table 10: Mapping of TerminalAuthentication Invoke - AUTHENTICATION-REQUEST

Item No	MM component TerminalAuthentication Invoke	DECT message AUTHENTICATION- REQUEST	Ref.	Map status	Note
1		protocol discriminator		X	
2	invokelIdentifier	transaction identifier		M	
3	componentType operation	message type		M	
4	gSMCipherInfo	cipher info		M	
5	gSMRand	RAND		M	
6	gSMPortableIdentity			X	note
NOTE: The NT provides the gSMPortableIdentity in case the component is transferred within an NCICs connection establishment message.					

Table 11: Mapping of AUTHENTICATION-REPLY - TerminalAuthentication Return Result

Item No	DECT message AUTHENTICATION-REPLY	MM component TerminalAuthentication Return Result	Ref.	Map status	Note
1	protocol discriminator			X	
2	transaction identifier	invokelIdentifier		M	
3	message type	componentType operation		M	
4	RES	gSMRes		M	

Table 12: Mapping of AUTHENTICATION-REJECT - TerminalAuthentication Return Error

Item No	DECT message AUTHENTICATION-REJECT	MM component TerminalAuthentication Return Error	Ref.	Map status	Note
1	protocol discriminator			X	
2	transaction identifier	invokerIdentifier		M	
3	message type	componentType operation		M	
4		errorValue		X	
5	reject reason	RejectReason		O	

7.2.7 Location registration

The PP may use this procedure to inform the network about its location, as defined in [13], subclause 9.2.1.

In addition to the requirements specified in subclause 7.2.3, the following applies.

Table 13: Mapping of LOCATE-REQUEST - LocationRegistration Invoke

Item No	DECT message LOCATE-REQUEST	MM component LocationRegistration Invoke	Ref.	Map status	Note
1	protocol discriminator			X	
2	transaction identifier	invokerIdentifier		M	
3	message type	componentType operation		M	
4	portable identity	gSMPortableIdentity		M	
5		gSMLocationRegistrationType		X	note
6	location area	gSMLocationAreaIdentity		M	
7	cipher info	gSMCipherInfo		M	
8	terminal capability	gSMPortableCapabilities		M	

NOTE: The FP provides normal updating.

7.2.7.1 FT initiates temporary identity assignment

Upon reception of a positive response from the network, the FT may assign a TPUI to the PT by including a <<PP- identity>> with a non-zero length in the LOCATE-ACCEPT message as specified in [10], subclause 8.28.

Although the temporary identity assignment procedure is part of the location registration and applies the same transaction identity, the handling of the TEMP-IDENTITY-ASSIGN-ACK is specified in [10], subclause 8.28 and hence outside the scope of the present document.

Depending on implementation, the network may:

- first reply with a LocationRegistration return result and afterwards initiate a stand-alone AssignIdentity mobility management procedure to assign a new temporary identity to the portable or;
- assign the new temporary identity by means of the LinkedAssignIdentity mobility management procedure which shall be linked to the LocationRegistration return result.

Table 14: Mapping of LocationRegistration Return Result - LOCATE-ACCEPT

Item No	MM component LocationRegistration Return Result	DECT message LOCATE-ACCEPT	Ref.	Map status	Note
1		protocol discriminator		X	
2	invokelIdentifier	transaction identifier		M	
3	componentType operation	message type		M	
4		portable identity		X	
5	gSMLocationAreaIdentity	location area		M	

7.2.7.2 FP receives temporary reject from network

In case the response received from the network concerns a temporary rejection, the FP should clear the transaction internally, that is without sending a LOCATE-REJECT message to the PP.

NOTE: The network may indicate the temporary rejection by means a special value within the <errorValue> e.g. congestion or within <gSMTerminalRejectValue> e.g. overload.

Table 15: Mapping of LocationRegistration Return Error - LOCATE-REJECT

Item No	MM component LocationRegistration Return Error	DECT message LOCATE-REJECT	Ref.	Map status	Note
1		protocol discriminator		X	
2	invokelIdentifier	transaction identifier		M	
3	componentType operation	message type		M	
4	errorValue			X	
5	RejectReason	reject reason		O	

7.2.8 Network initiated ciphering

The network may use this procedure to initiate encryption of the radio connection as defined in [13], subclause 9.3.4.

There are no requirements in addition to the ones specified in 7.2.1, generic interworking procedure for network initiated mobility management transactions with explicit acknowledgement.

NOTE: It should be noted that in this case the FP initiates the result component upon reception of a local primitive rather than upon reception of a DECT network layer message.

Table 16: Mapping of Ciphering Invoke - CIPHER-REQUEST

Item No	MM component Ciphering Invoke	DECT message CIPHER-REQUEST	Ref.	Map status	Note
1		protocol discriminator		X	
2	invokelIdentifier	transaction identifier		M	
3	componentType operation	message type		M	
4	gSMCipherKey			X	note 1
5	gSMPortableIdentity			X	note 2
NOTE 1: The NT derives the cipher key during authentication and provides it to the FP in every CIPHER-REQUEST message. The key is to be used by the FP and need not be passed to the PP, that derives the cipher key itself.					
NOTE 2: The NT provides the gSMPortableIdentity in case the component is transferred within an NCICs connection establishment message.					

Table 17: Mapping of CIPHER- REJECT - Ciphering Return Error

Item No	DECT message CIPHER-REJECT	MM component Ciphering Return Error	Ref.	Map status	Note
1	protocol discriminator			X	
2	transaction identifier	invokelIdentifier		M	
3	message type	componentType operation		M	
4		errorValue		X	
5	reject reason	RejectReason		O	

7.2.9 Temporary Identity Assignment

The network may use this procedure to assign a new temporary identity as defined in [13], subclause 9.3.6 as a stand-alone mobility management transaction.

There are no requirements in addition to the ones specified in 7.2.1, generic interworking procedure for network initiated mobility management transactions with explicit acknowledgement.

Table 18: Mapping of Assign Identity Invoke - TEMPORARY-IDENTITY-ASSIGN

Item No	MM component Assign Identity	DECT message TEMPORARY-IDENTITY- ASSIGN	Ref.	Map status	Note
1		protocol discriminator		X	
2	invokelIdentifier	transaction identifier		M	
3	componentType operation	message type		M	
4	gSMNewTMSI	portableidentity		M	
5	GSMLocationAreaIdentity	location area		M	
6	GSMPortableIdentity			X	note
NOTE: The NT provides the gSMPortableIdentity in case the component is transferred within an NCICs connection establishment message.					

Table 19: Mapping of TEMPORARY-IDENTITY-ASSIGN-ACK - Assign Identity Return Result

Item No	DECT message TEMPORARY-IDENTITY- ASSIGN-ACK	MM component Assign Identity Return Result	Ref.	Map status	Note
1	protocol discriminator			X	
2	transaction identifier	invokelIdentifier		M	
3	message type	componentType operation		M	

7.2.10 Linked Temporary Identity Assignment

The network may use this procedure to assign a new temporary identity as defined in [13], subclause 9.3.6 immediately following after a location registration mobility management transaction.

There are no requirements in addition to the ones specified in 7.2.1, generic interworking procedure for network initiated mobility management transactions with explicit acknowledgement.

Table 20: Mapping of Linked Assign Identity Invoke - TEMPORARY-IDENTITY-ASSIGN

	MM component	DECT message			
Item No	Linked Assign Identity	TEMPORARY-IDENTITY-ASSIGN	Ref.	Map status	Note
1		protocol discriminator		X	
2	invokelIdentifier	transaction identifier		M	
3	componentType operation	message type		M	
4	gSMNewTMSI	portableidentity		M	
5		location area		X	note

NOTE: The FP provides the location area which have been received in the location registration procedure to which the temporary identity assign invoke was linked.

Table 21: Mapping of TEMPORARY-IDENTITY-ASSIGN-ACK - Linked Assign Identity Return Result

	DECT message	MM component			
Item No	TEMPORARY-IDENTITY-ASSIGN-ACK	Linked Assign Identity Return Result	Ref.	Map status	Note
1	protocol discriminator			X	
2	transaction identifier	invokelIdentifier		M	
3	message type	componentType operation		M	

7.2.11 Detach

The PP may use this procedure to inform the network about its deactivated status as defined in [13], subclause 9.2.3.

There are no requirements in addition to the ones specified in 7.2.4, generic interworking procedure for portable initiated mobility management transactions with no explicit acknowledgement.

Table 22: Mapping of DETACH - Detach

	DECT message	MM component			
Item No	DETACH	Detach	Ref.	Map status	Note
1	protocol discriminator			X	
2	transaction identifier	invokelIdentifier		M	
3	message type	componentType operation		M	
4	portable identity	gSMPortableIdentity		M	

7.3 Call control procedures

7.3.1 General

The FT does not need to support IAP [9] options exceeding the DECT access to GSM requirements as defined in [11].

Unless specified otherwise, the call control interworking requirements as defined in [9] apply; the requirements described in this chapter only concern additions and/or modifications to IAP.

7.3.2 Outgoing call

The interworking procedures as defined in [9], subclause 5.2.1.1.1 apply with the following modifications.

The FP does not need to support the DECT en-block dialling procedures. This includes both the transfer of the complete destination number within a <<Called party number>> either carried within a {CC-SETUP} or a {CC-INFO} message.

The FP shall apply case a) as defined in [9], subclause 5.2.1.1.1; it shall not delay the transfer of the SETUP message to the network until it has collected further dialling information.

NOTE 1: An early transfer of the SETUP to the network is required to facilitate an early start of ciphering, which may be used for the encryption of the dialling information.

In case of a point to multi-point configuration, the FP shall provide the FP-address within the <<Calling party number>> information element. The FP should not transfer the <<Calling party number>>, if received from the PT, towards the network as specified in [9], subclauses 5.2.4.2.4 and 5.2.4.2.11.

FP shall transfer <<Portable identity>> (IPUI) and <<Basic service>> (normal) as parameters within an MM GSMOutgoingCallMMInfo invoke component, as described in the following.

NOTE 2: The network may delay the sending of the {SETUP-ACK} message until the completion of network initiated ciphering procedure (in order to cipher dialling information).

It is assumed that the MSC transforms a called party number received in overlap mode, to the required en block mode which is normally applicable for GSM.

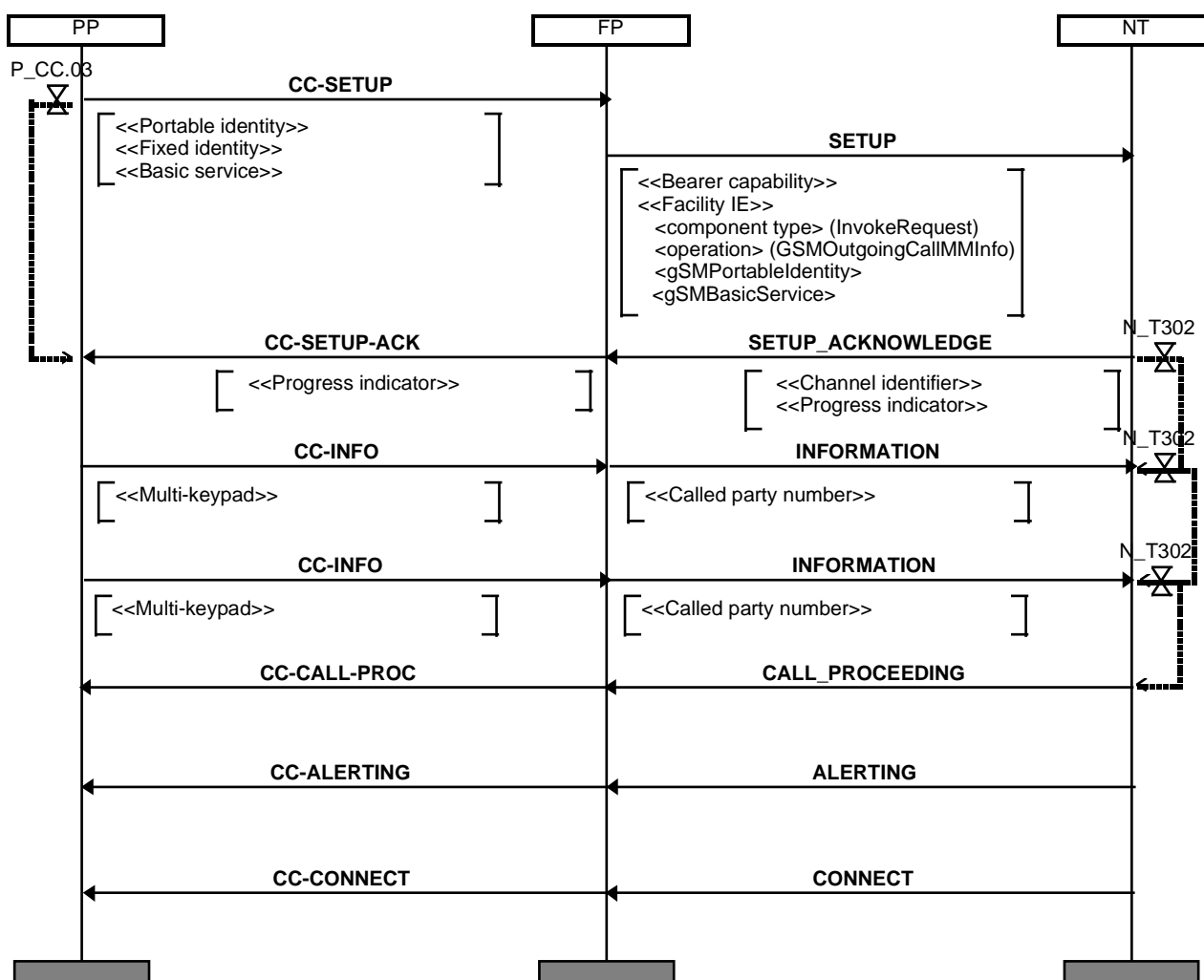

NOTE: Authentication and ciphering may be done in parallel to call establishment. The network may delay sending of SETUP_ACK until completion of ciphering.

Figure 11: Successful outgoing call, typical sequence

Table 23: Mapping of CC-SETUP - SETUP

Item No	DECT message CC-SETUP	GSM message SETUP	Ref.	Map status	Note
1	protocol discriminator	protocol discriminator		M	
2	transaction identifier	transaction identifier		M	
3	message type	message type	8.3.2	M	
4	basic service	bearer capability	8.4.2	M	note 1
5	-	channel identification		X	note 2
6	-	facility		X	
6.1	-	invokelIdentifier		X	
6.2	-	componentType		X	
6.3	-	operation		X	
6.4	portable identity	gSMPortableIdentity	8.4.2	M	
6.5	basic service	gSMBasicService	8.4.2	M	note 1
7	-	calling party number		X	note 3

NOTE 1: The <<basic service>> is mapped to both the <<bearer capability>> and the <gSMBasicService>.
NOTE 2: It is optional for the FT to include this information element.
NOTE 3: The FT may include its FT- address (E.164 number) within the <<calling party number>>.

Table 24: Mapping of SETUP-ACKNOWLEDGE - CC-SETUP-ACK

Item No	GSM message SETUP-ACKNOWLEDGE	DECT message CC-SETUP-ACK	Ref.	Map status	Note
1	protocol discriminator	protocol discriminator		M	
2	transaction identifier	transaction identifier		M	
3	message type	message type	8.3.1	M	
4	progress indicator	progress indicator	8.4.1	M	

Table 25: Mapping of CC-INFO - INFORMATION

Item No	DECT message CC-INFO	GSM message INFORMATION	Ref.	Map status	Note
1	protocol discriminator	protocol discriminator		M	
2	transaction identifier	transaction identifier		M	
3	message type	message type	8.3.2	M	
4	multi- keypad	called party number	8.4.2	C251	

C251: This mapping is required (in overlap sending state) in case the information contained in <<multi-keypad>> concerns dialling information (and DTMF generation, which shall be performed by the FT, has not been activated).

Table 26: Mapping of CALL PROCEEDING - CC-CALL-PROC

Item No	GSM message CALL PROCEEDING	DECT message CC-CALL-PROC	Ref.	Map status	Note
1	protocol discriminator	protocol discriminator		M	
2	transaction identifier	transaction identifier		M	
3	message type	message type	8.3.1	M	
4	channel identification	-		X	
5	progress indicator	progress indicator	8.4.1	M	

NOTE: For outgoing calls fall back procedures are outside the scope of the present document. Therefore, in this message support of <<bearer capability>> is not required.

Table 27: Mapping of ALERTING - CC-ALERTING

Item No	GSM message ALERTING	DECT message CC-ALERTING	Ref.	Map status	Note
1	protocol discriminator	protocol discriminator		M	
2	transaction identifier	transaction identifier		M	
3	message type	message type	8.3.1	M	
4	channel identification	-		X	
5	progress indicator	progress indicator	8.4.1	M	

NOTE: For outgoing calls fall back procedures are outside the scope of the present document. Therefore, in this message support of <<bearer capability>> is not required.

Table 28: Mapping of CONNECT - CC-CONNECT

Item No	GSM message CONNECT	DECT message CC-CONNECT	Ref.	Map status	Note
1	protocol discriminator	protocol discriminator		M	
2	transaction identifier	transaction identifier		M	
3	message type	message type	8.3.1	M	
4	channel identification	-		X	
5	progress indicator	progress indicator	8.4.1	M	

NOTE: For outgoing calls fall back procedures are outside the scope of the present document. Therefore, in this message support of <<bearer capability>> is not required.

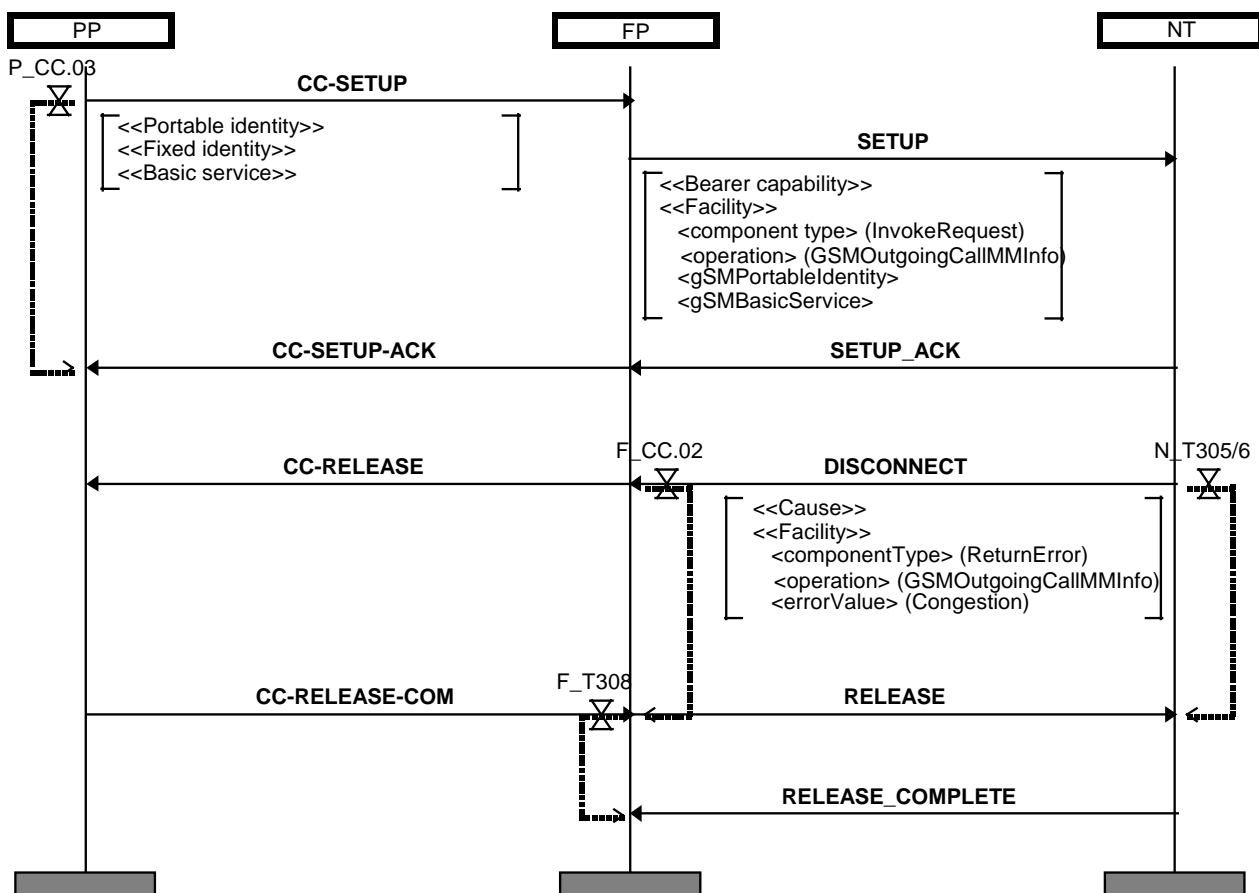

Figure 12: Outgoing call failure, e.g. no resources in network

7.3.3 Incoming call

The interworking procedures as defined in [9], subclause 5.2.1.1.2, apply with the following modifications.

The FP does not need to support the overlap receiving procedures.

In order to check if it is a compatible destination, the FT shall check the <<Bearer capability>> and the <<Progress indicator>> information elements if present in the SETUP message received from the network. The FT shall accept the call in case one of the following conditions is met the <<Bearer capability>> is set to « speech » OR to « 3,1 kHz audio ».

NOTE: GAP [10] does not include requirements for the support of voice band data. In case the speech service is used for voice band data, the quality of service may be limited due to the application of speech processing techniques e.g. muting/echo control.

In case of a point to multi-point configuration, the FP shall accept the call if the destination provided within the <<Called party number>> information element corresponds to its FP-address.

The FP should not interwork the <<Called party number>> information element across the air interface as specified in [9], subclause 5.2.4.1.22.

The FP shall transfer the <gSMPortableIdentity> and the <gSMSignal> parameters received within an MM GSMIncomingCallMMInfo invoke component to the corresponding DECT information elements (<<Portable identity>> (IPUI), <<Signal>>...) as described in 8 message mappings.

Upon reception of an incoming call request, the FP may have to retrieve the PARK of the PP by initiating the Identification of PT procedure as defined in [10], subclause 8.22.

For incoming calls the FT shall apply fall back to a service compatible with [10].

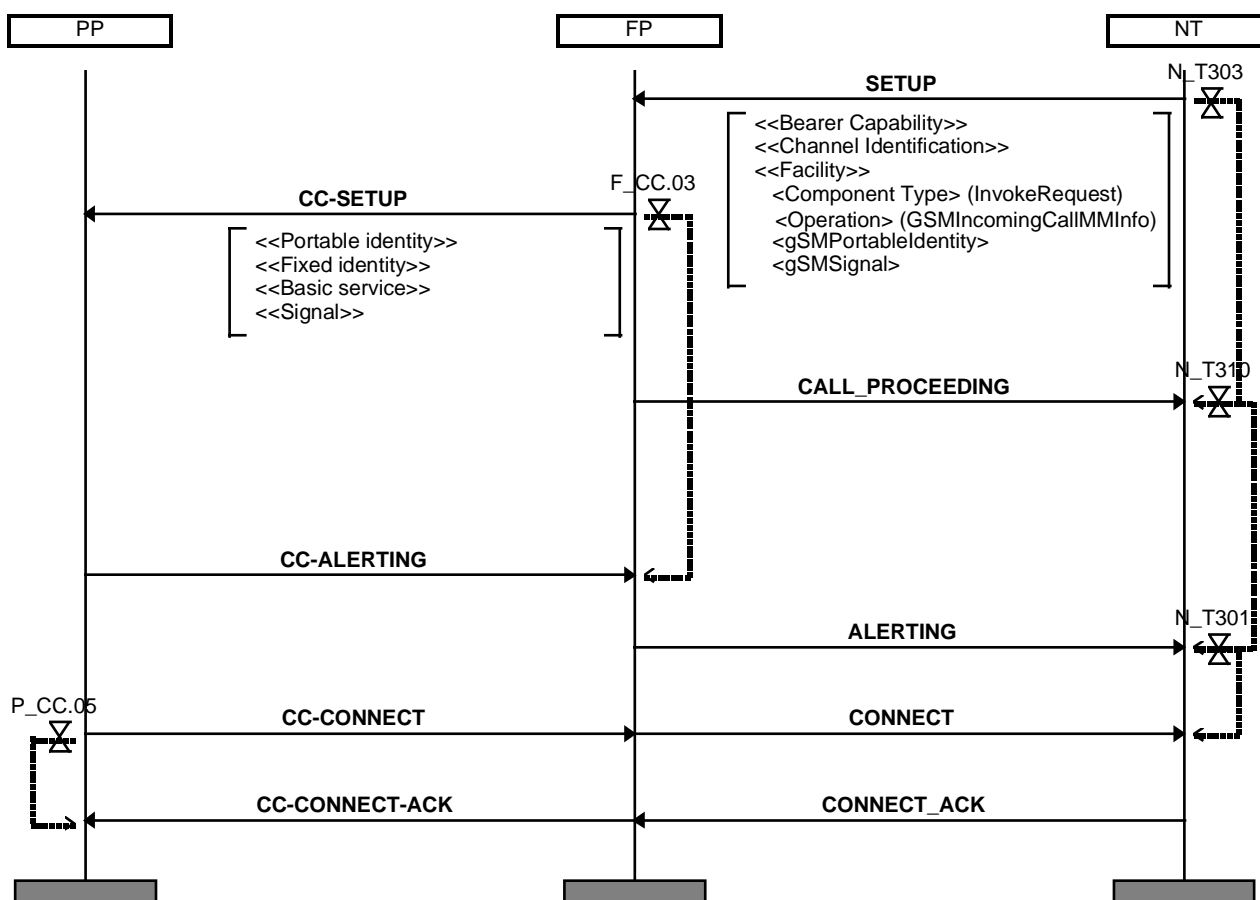

NOTE: Authentication and ciphering may be done prior or in parallel to call establishment.

Figure 13: Successful incoming call, typical scenario

Table 29: Mapping of SETUP - CC-SETUP

Item No	GSM message SETUP	DECT message CC-SETUP	Ref.	Map status	Note
1	protocol discriminator	protocol discriminator		M	
2	transaction identifier	transaction identifier		M	
3	message type	message type	8.3.1	M	
4	bearer capability	basic service	8.4.1	M	
5	channel identification	-		X	
6	facility			X	
6.1	invokeldentifier			X	
6.2	componentType			X	
6.3	operation			X	
6.4	gSMPortableIdentity	portable identity	8.4.1	M	
6.5	gSMSignal	signal	8.4.1	M	
7	calling party number	calling party number	8.4.1	M	
8	called party number	-		X	note
9	-	fixed identity		X	

NOTE: The called party number may include the FT- address (E.164 number); hence it is not relevant to map this information to the PT.

Table 30: Mapping of CC-ALERTING - ALERTING

Item No	DECT message CC-ALERTING	GSM message ALERTING	Ref.	Map status	Note
1	protocol discriminator	protocol discriminator		M	
2	transaction identifier	transaction identifier		M	
3	message type	message type	8.3.2	M	
4	-	bearer capability		X	
5	-	channel identification		X	

Table 31: Mapping of CC-CONNECT - CONNECT

Item No	DECT message CC-CONNECT	GSM message CONNECT	Ref.	Map status	Note
1	protocol discriminator	protocol discriminator		M	
2	transaction identifier	transaction identifier		M	
3	message type	message type	8.3.2	M	
4	-	bearer capability		X	
5	-	channel identification		X	

Table 32: Mapping of CONNECT-ACKNOWLEDGE - CC-CONNECT-ACK

Item No	GSM message CONNECT- ACKNOWLEDGE	DECT message CC-CONNECT-ACK	Ref.	Map status	Note
1	protocol discriminator	protocol discriminator		M	
2	transaction identifier	transaction identifier		M	
3	message type	message type	8.3.1	M	

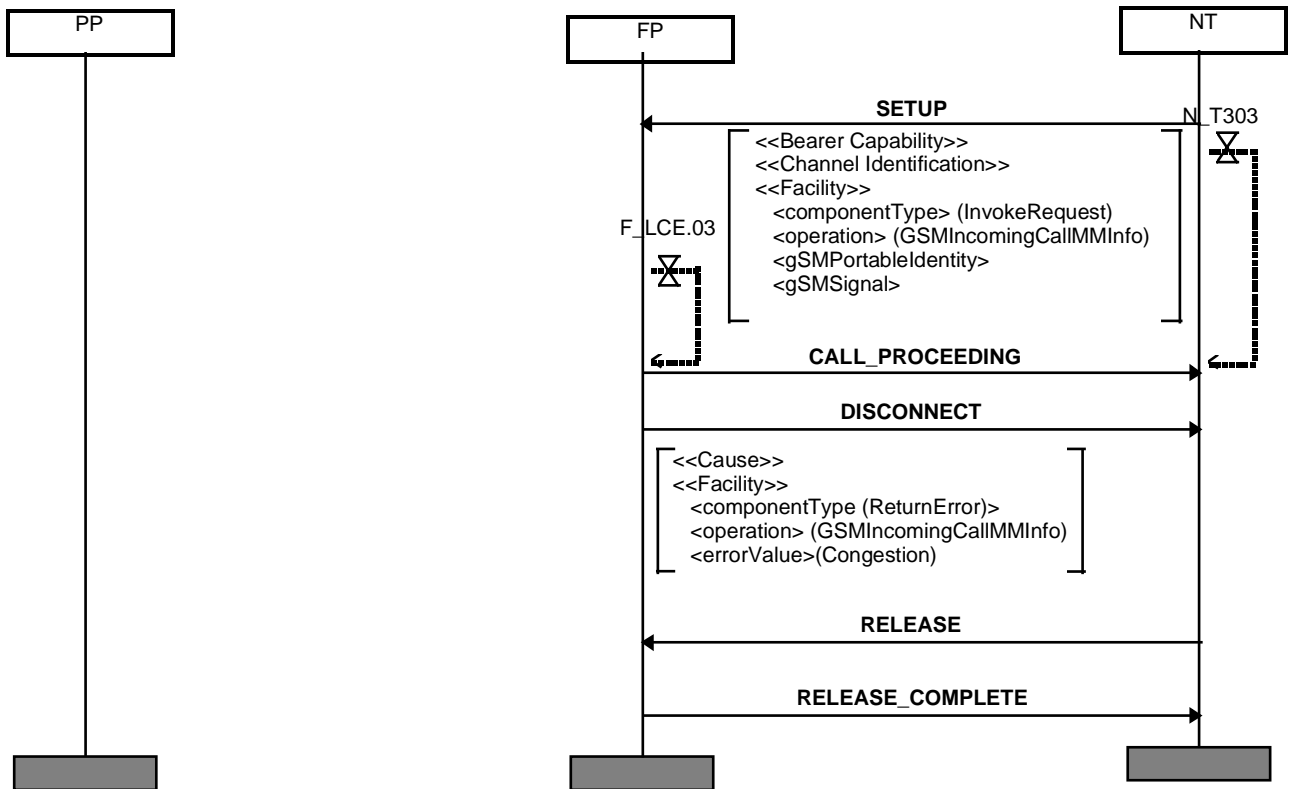

Figure 14: Incoming call failure, FT resources unavailable

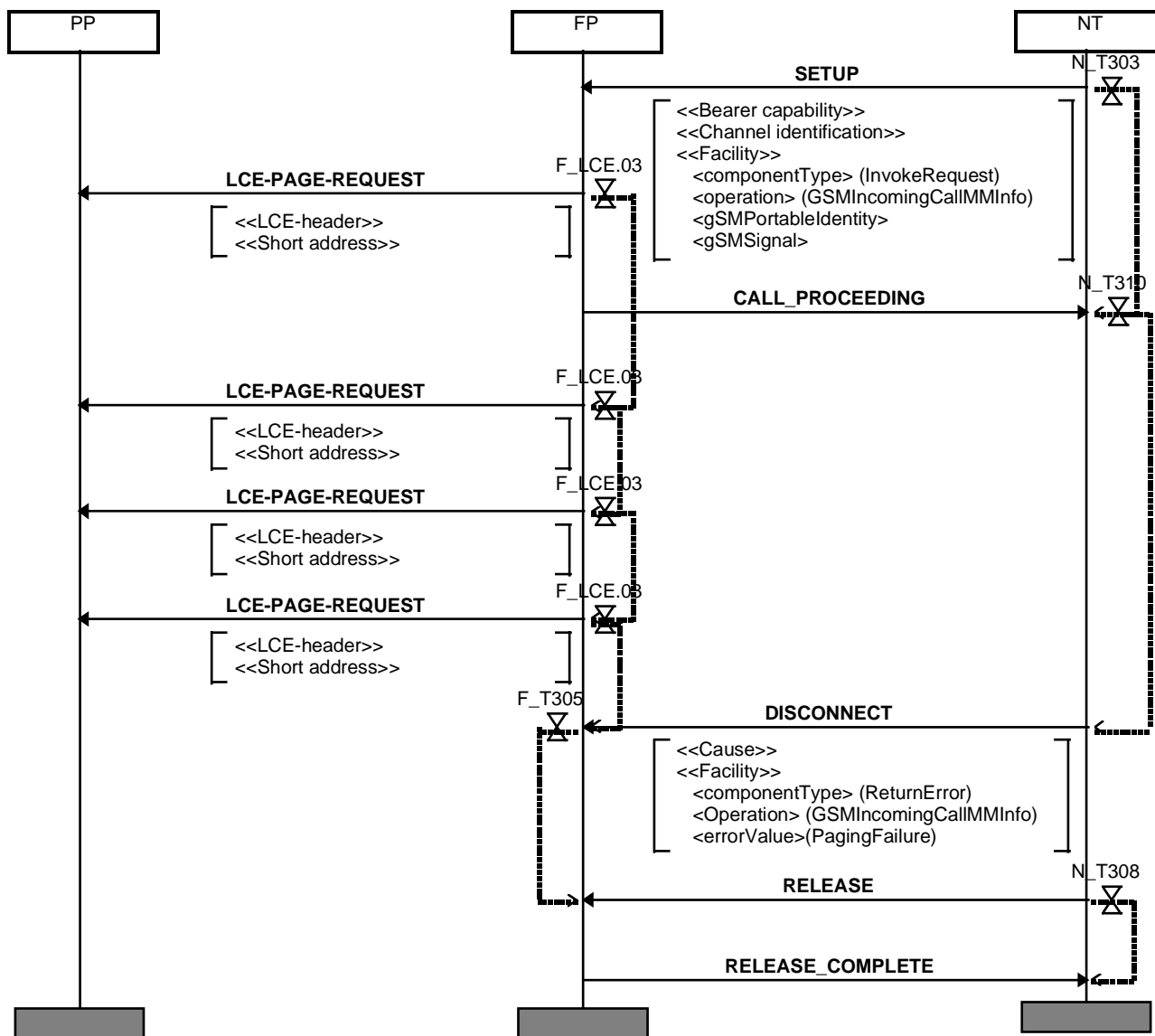

Figure 15: Incoming call failure, no response to paging request

7.3.4 Call progress information transfer

In case the network want to inform the user about the progress of a call without changing the call state, it may send a PROGRESS message. The FT shall interworking this message as specified in the following:

Table 33: Mapping of PROGRESS - CC-INFO

Item No	GSM message PROGRESS	DECT message CC-INFO	Ref.	Map status	Note
1	protocol discriminator	protocol discriminator		M	
2	transaction identifier	transaction identifier		M	
3	message type	message type	8.3.1	M	
4	progress indicator	progress indicator	8.4.1	M	

7.3.5 Call release

The interworking procedures as defined in [9], subclause 5.2.1.1.3 apply with the following modifications:

7.3.5.1 Network initiated release

In case of call release initiated by the NT with in band tones or announcements provided, the FP shall interwork the received DISCONNECT message including a <<Progress indicator>> information element to a {CC-INFO} message as described in 8, message mappings.

The FP may transfer the <<Release reason>> information element received within a {CC-RELEASE} message to the <rejectReason> parameter within an MM GSMOutgoingCallMMInfo return error component as described in the following message specifications.

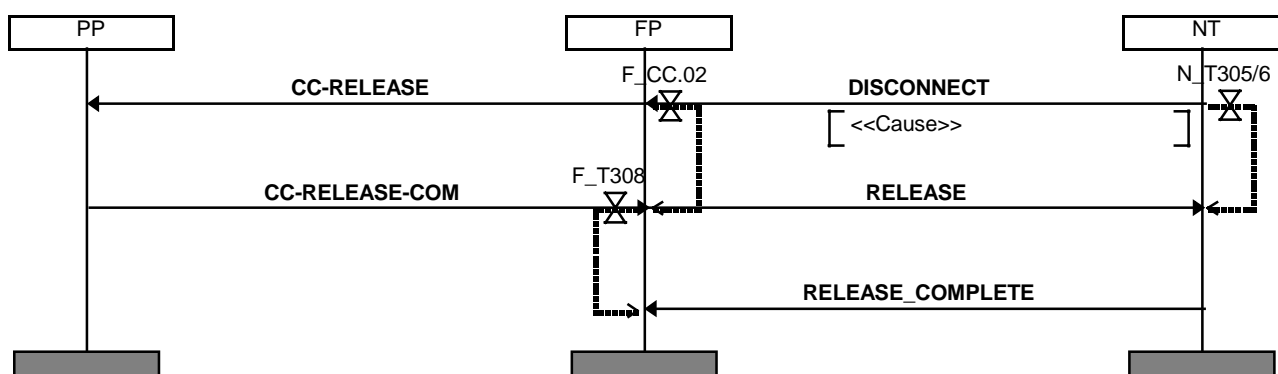

Figure 16: Normal call release, network initiated

Table 34: Mapping of DISCONNECT - CC-INFO

Item No	GSM message DISCONNECT	DECT message CC-INFO	Ref.	Map status	Note
1	protocol discriminator	protocol discriminator		M	
2	transaction identifier	transaction identifier		M	
3	message type	message type	8.3.1	M	
4	progress indicator	progress indicator	8.4.1	M	

Table 35: Mapping of DISCONNECT - CC-RELEASE

Item No	GSM message DISCONNECT	DECT message CC-RELEASE	Ref.	Map status	Note
1	protocol discriminator	protocol discriminator		M	
2	transaction identifier	transaction identifier		M	
3	message type	message type	8.3.1	M	
6	facility			X	
6.1	invokelIdentifier			X	
6.2	componentType			X	
6.3	operation			X	
6.4	errorValue			X	
6.5	RejectReason	release reason	8.4.1	O	

Table 36: Mapping of CC-RELEASE-COM - RELEASE

Item No	DECT message CC-RELEASE-COM	GSM message RELEASE	Ref.	Map status	Note
1	protocol discriminator	protocol discriminator		M	
2	transaction identifier	transaction identifier		M	
3	message type	message type	8.3.2	M	

7.3.5.2 PT initiated release

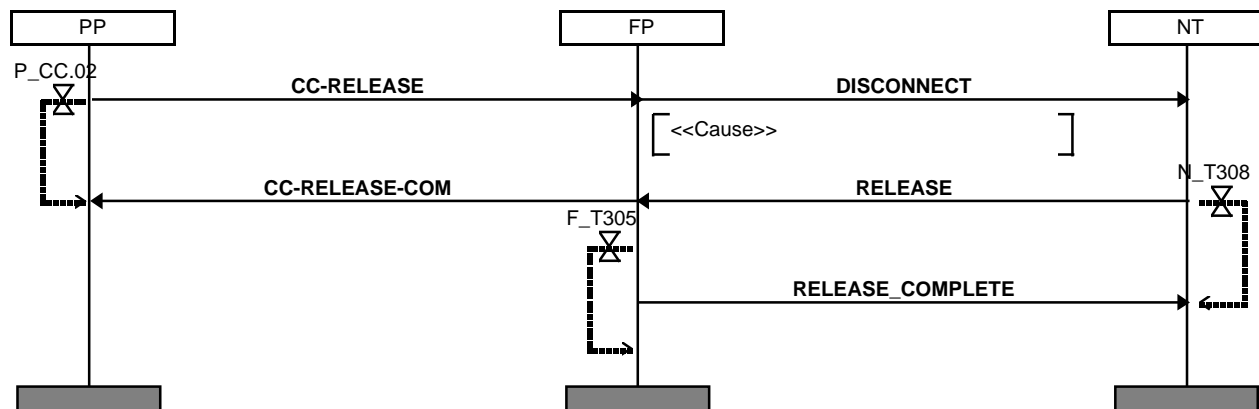

Figure 17: Normal call release, terminal initiated

Table 37: Mapping of CC-RELEASE - DISCONNECT

Item No	DECT message CC-RELEASE	GSM message DISCONNECT	Ref.	Map status	Note
1	protocol discriminator	protocol discriminator		M	
2	transaction identifier	transaction identifier		M	
3	message type	message type	8.3.2	M	
4	-	cause			

Table 38: Mapping of RELEASE - CC-RELEASE-COM

Item No	GSM message RELEASE	DECT message CC-RELEASE-COM	Ref.	Map status	Note
1	protocol discriminator	protocol discriminator		M	
2	transaction identifier	transaction identifier		M	
3	message type	message type	8.3.1	M	

7.3.5.3 Other release cases

Table 39: Mapping of RELEASE - CC-RELEASE

Item No	GSM message RELEASE	DECT message CC-RELEASE	Ref.	Map status	Note
1	protocol discriminator	protocol discriminator		M	
2	transaction identifier	transaction identifier		M	
3	message type	message type	8.3.1	M	

Table 40: Mapping of RELEASE-COMplete - CC-RELEASE-COM

Item No	GSM message	DECT message	Ref.	Map status	Note
	RELEASE-COMplete	CC-RELEASE-COM			
1	protocol discriminator	protocol discriminator		M	
2	transaction identifier	transaction identifier		M	
3	message type	message type	8.3.1	M	

Table 41: Mapping of CC-RELEASE-COM - DISCONNECT

Item No	DECT message	GSM message	Ref.	Map status	Note
	CC-RELEASE-COM	DISCONNECT			
1	protocol discriminator	protocol discriminator		M	
2	transaction identifier	transaction identifier		M	
3	message type	message type	8.3.2	M	
4	-	cause		X	
5	-	facility		X	
5.1	-	invokelIdentifier		X	
5.2	-	componentType		X	
5.3	-	operation		X	
5.4	-	errorValue		X	
5.5	release reason	RejectReason	8.4.2	O	note
NOTE: The MM return error component applies in case of an incoming call failure, rejected by the PT. In this case the release reason, if provided, may be mapped to the <RejectReason>.					

7.3.6 Keypad information transfer

The interworking procedures as defined in [9], subclause 5.2.2.1 apply with the following modifications.

Upon reception of a request for "go to DTMF dialling, defined tone length", the FP shall start the generation of DTMF tones. The handling of supplementary service related keypad information signalling is outside the scope of the present document.

7.4 Other interworking procedures

7.4.1 Interaction in-between MM transactions

The FP shall apply the priority rules as described in [6], subclause 15.5. These priority rules imply that only one MM transaction may be initiated towards the PP at a time.

NOTE 1: The priority rules is also take into account non-interworked procedures e.g. an FT- initiated identity request procedure.

The FP shall queue a network initiated MM invoke request that is received while another FP-initiated mobility management transaction is active. The FP may either queue or reject a network initiated MM invoke request that is received while another network initiated mobility management transaction is active.

In case the FP rejects the MM invoke component, is shall apply the procedures as defined in subclause 7.2.1 generic interworking procedures, network initiated transaction, explicit acknowledgement. In this case, the FP shall apply error value « priority rule violation ».

NOTE 2: Within the GSM network, more than one nodes may initiate mobility management transactions. This is one of the reasons why the GSM network is not required to provide co-ordination between mobility transactions.

NOTE 3: There are no limitations to the number of parallel MM- transactions the GSM network may initiate. However, considering that larger queue sizes result in MM- timer problems, there seems no justification to mandate the FT to support queuing of network initiated MM- transactions.

7.4.2 Interactions between MM- and CC- transactions

The GAP [10], subclause 6.9.6 defines the FT requirements concerning the states in which the MM procedures shall be supported.

7.4.3 Other interactions between local and interworked procedures

Both [11] and [13] specify procedures for which there is no interworking procedure defined in the present document; these procedures are local to the interface. However, some of these procedure may interact with procedures for which interworking is defined. The following cases have been identified: upon reception of a STATUS or RESTART message, the FT may have to initiate clearing of call control and or mobility management transactions.

NOTE: There are no requirements concerning the interactions required upon reception of a location cancellation; the FT need not initiate clearing of ongoing transactions upon receiving a location cancellation invoke component.

7.4.4 Error handling

There are no requirements regarding error handling.

NOTE: The above implies that upon NCICs connection (establishment) failure, the FT need not immediately reject the associated MM- transaction. Likewise, in case of a radio connection failure, the FT need not immediately initiate clearing of the related transactions towards the NT. There are no requirements specified since this is not required to achieve interoperability. However, the drawback is that that radio resources may be occupied longer than required.

8 Message mappings

8.1 General

In the present document, the following approach/conventions are used:

- 1) the mapping status is based on the alpha interface standard [13], table 1 (and not on GAP [10]);
- 2) the message mapping specifications only cover messages/information elements that are relevant for the GSM application. The handling of other (optional) messages/information elements is outside the scope of the present document;
- 3) for informative reasons, the mapping interworking specifications include information elements that are not mapped but required on one of the interfaces;
- 4) the mapping of information elements and its fields/values as specified in IAP [9] applies unless explicitly stated otherwise; the present document only defines additions and/or modifications;
- 5) MM information is transferred within NCICs messages. However, for the mapping of MM information it is irrelevant which NCICs message was used to transfer the information. Therefore, for MM- messages the mapping tables only show the mapping between the MM components and the DECT MM- messages;
- 6) the MM mapping tables do not include addressing parameters which are never mapped. The handling of these parameters is clarified by means of an example;
- 7) the order of information elements within the message interworking specifications need not be in accordance to the requirements of the DECT and/or alpha interface specifications;
- 8) all fields/parameters are mapped transparently unless explicitly specified otherwise.

NOTE: The reasons for specifying call control message/information mapping are as follows:

- 1) the status of message/information mappings and or interworking procedures differs from IAP [9];
- 2) the message/information mapping or interworking procedures is different from IAP e.g. to overcome the limitations of a GAP terminal. For <<called/called party number party number>> and the <<release reason>> information elements, the present document specifies requirements that conflict with the requirements specified in IAP.

8.2 Mobility management message/component mapping

8.2.1 General

The references in the tables of the present subclause refer to the present document.

8.2.1a MM component to DECT message

NOTE 1: No requirements are specified concerning PT- initiated transactions that are not required for GSM, e.g. PT- initiated termination of access rights; whether FT or LE should reject this transaction.

NOTE 2: The status corresponds with the user side status for the corresponding feature as specified in the alpha interface standard [13], table 1.

Table 42: MM component to DECT message mapping

Item No	GSM component	DECT message	Ref.	Map Status
1	Ciphering Invoke	CIPHER_REQUEST	7.2.8	M
2	IdentityRequest Invoke	IDENTITY_REQUEST	7.2.5	M
3	LocationRegistration Return Result	LOCATE_ACCEPT	7.2.7	M
4	LocationRegistration Return Error	LOCATE_REJECT	7.2.7	M
5	TerminalAuthentication Invoke	AUTHENTICATION_REQUEST	7.2.6	M
6	AssignIdentity	TEMPORARY-IDENTITY-ASSIGN	7.2.9	M
7	LinkedAssignIdentity	TEMPORARY-IDENTITY-ASSIGN	7.2.10	M

NOTE: The handling of non- interworked messages is outside the scope of the present document.

8.2.2 DECT message to MM component

NOTE 1: No requirements are specified concerning PT- initiated transactions that are not required for GSM e.g. PT- initiated termination of access rights; whether FT or LE should reject this transaction.

NOTE 2: The status is based on the alpha interface standard [13] and not on GAP.

Table 43: DECT message to MM component mapping

Item No	DECT message	GSM component	Ref.	Map Status
1	AUTHENTICATION_REPLY	TerminalAuthentication Return Result	7.2.6	M
2	AUTHENTICATION_REJECT	TerminalAuthentication Return Error	7.2.6	M
3	CIPHER_REJECT	Ciphering Return Error	7.2.8	O
4	IDENTITY_REPLY	IdentityRequest Return Result	7.2.5	M
5	IDENTITY_REPLY	IdentityRequest Return Error	7.2.5	M
6	LOCATE_REQUEST	LocationRegistration Invoke	7.2.7	M
7	TEMPORARY-IDENTITY-ASSIGN-ACK	AssignIdentity Return Result	7.2.9	M
8	TEMPORARY-IDENTITY-ASSIGN-ACK	LinkedAssignIdentity Return Result	7.2.10	M
9	DETACH	Detach	7.2.11	M

NOTE 1: The handling of non- interworked messages is outside the scope of the present document.
NOTE 2: Whether the linked or not linked return result is used, depends on the last received invoke component.

8.3 Call control message mapping

8.3.1 General

The references in the tables of the present subclause refer to the present document.

8.3.1a DSS1 message to DECT message

Table 44: DSS1 message to DECT message mapping

Item No	GSM message	DECT message	Ref.	Map Status
1	ALERTING	CC-ALERTING	7.3.2	M
2	CALL PROCEEDING	CC-CALL-PROC	7.3.2	M
3	CONNECT	CC-CONNECT	7.3.2	M
4	CONNECT-ACKNOWLEDGE	CC-CONNECT-ACK	7.3.3	M
5	PROGRESS	CC-INFO (note 1)	7.3.4	O
6	DISCONNECT	CC-INFO (note 1)	7.3.5	O
7	DISCONNECT	CC-RELEASE	7.3.5	M
8	RELEASE	CC-RELEASE-COM	7.3.5	M
9	RELEASE-COMPLETE	CC-RELEASE-COM	7.3.5	M
10	SETUP	CC-SETUP	7.3.3	M
11	SETUP-ACKNOWLEDGE	CC-SETUP-ACK	7.3.2	M

NOTE 1: At DECT access to GSM the PP's need not support the handling of a <<Progress indicator>> contained within a CC-INFO message. Hence, it is not applicable to mandate the FT to supports this interworking.

NOTE 2: The handling of non-interworked messages is outside the scope of the present document.

8.3.2 DECT message to DSS1 message

Table 45: DECT message to DSS1 message mapping

Item No	DECT message	GSM message	Ref.	Map Status
1	CC-ALERTING	ALERTING	7.3.3	M
2	CC-CONNECT	CONNECT	7.3.2	M
3	CC-INFO	INFORMATION	7.3.2	M
4	CC-RELEASE	DISCONNECT	7.3.5	M
5	CC-RELEASE-COM	DISCONNECT	7.3.5	M
6	CC-RELEASE-COM	RELEASE	7.3.5	M
7	CC-SETUP	SETUP	7.3.2	M
8	-	CALL PROCEEDING	7.3.3	X

NOTE 1: Mapping of CC-INFO does not apply in case of FT- generated DTMF sending.

NOTE 2: In case the network indicates that fallback is possible, the FT shall indicate the selected <<bearer capability>> within {CALL PROCEEDING}.

NOTE 3: The handling of non- interworked messages is outside the scope of the present document.

8.4 Information element/parameter mapping

8.4.1 General

The references in the tables of the present subclause refer to the present document unless otherwise specified.

8.4.1a GSM information element/parameter to DECT information element

Table 46: GSM information element/parameter to DECT information element mapping

Item No	GSM message	DECT message	Ref.	Map Status
1	bearer capability	basic service (note 3)	[18], 5.2.5.1.1	
2	calling party number	calling party number	[18], 5.2.5.1.2	
3	_componentType	message type	8.4.1.2	
4	_operation			
5	invoke identifier	transaction identifier	8.4.1.4	
8	_gSMCipherInfo	cipher info	8.4.1.1	
9	_gSMLocationAreaIdentity	location area	8.4.1.1	
10	_gSMIdentityType	identity type	8.4.1.3	
11	_gSMPortableIdentity	portable identity	8.4.1.1	
12	_gSMRand	RAND	8.4.1.1	
13	_gSMSignal	signal	8.4.1.1	
14	_gSMPortableCapabilities	terminal capability	8.4.1.1	
15	_RejectReason	reject reason	8.4.1.1	
16	progress indicator	progress indicator (note 4)	[18], 5.2.5.1.15	

NOTE 1: This table only specifies information elements/parameters that are not interworked/mapped; the handling of other information elements/parameters is defined by the respective interface protocol specifications (GAP [10], alpha interface [18]).

NOTE 2: The mapping status is included in the message interworking/mapping specifications.

NOTE 3: The present document only requires support of the mapping for code value corresponding with "speech" and "3,1 kHz audio", see subclause 7.4.3.

NOTE 4: Since GAP only requires support of code value "0", value "8" should be interworked to value "0" to ensure that the U- plane is connected.

8.4.1.1 General/transparent mapping

Across the alpha interface, the GSM mobility management parameters include the corresponding DECT information elements which are defined as octet strings. The octet string received from the NT is inserted without further processing into the DECT message; there is no real interworking. However, the FT has to ensure that across the air interface the information elements are in the correct order as defined in EN 300 175-5 [6].

NOTE 1: [13] defines the order in which the parameters are transferred across the alpha interface.

NOTE 2: All of the following DECT IE's are defined as octet/bit strings: IPEI, IPUI, PortableCapabilities, GSMLocationAreaIdentity, CipherKey, CipherInfo, BasicService, Rand, RejectReason, Signal.

8.4.1.2 <_componentType>+ <_operation> - << message type>>

Table 47: <_componentType>+ <_operation> - << message type>> mapping

Item No	GSM information <_operation>	GSM information <_componentType>	DECT information << message type>>	Map status	Note
1	Ciphering	Invoke	CIPHER_REQUEST		
2	IdentityRequest	Invoke	IDENTITY_REQUEST		
3	LocationRegistration	Return Result	LOCATE_ACCEPT		
4	LocationRegistration	Return Error	LOCATE_REJECT		
5	TerminalAuthentication	Invoke	AUTHENTICATION_REQUEST		
6	AssignIdentity	Invoke	TEMPORARY-IDENTITY-ASSIGN		
7	LinkedAssignIdentity	Invoke	TEMPORARY-IDENTITY-ASSIGN		

NOTE 1: The <_componentType> defines whether the MM component concerns an invoke, a return result or reject component. The <_operation> on the other hand defines the nature of the operation e.g. location registration and/or network authentication. Across the DECT air interface, these two information fields are combined in the message type that indicated e.g. for a LOCATE-REQUEST the procedure is location registration and the type is an invoke.

NOTE 2: Similar information is contained in subclause 8.2. Therefore, the mapping status is not repeated in this table.

8.4.1.3 <_gSMIdentityType> - <<identity type>>

The coding of <_gSMIdentityType> is specified as an enumerated type. The value of this enumerated type needs to be interworked to the <type> field of the <<Identity type>> as defined in the following.

Table 48: <_componentType>+ <_operation> - << message type>> mapping

Item No	GSM information <_gSMIdentityType>	DECT information < type>	Ref.	Map status	Note
1	imsi (0)	ipui (H'0)		M	
2	tmsi (1)	tmsi (H'74)		M	

NOTE: All other values are outside the scope of the present document.

8.4.1.4 <_invokeIdentifier> - << transaction identifier>>

The <_invokeIdentifier> and the << transaction identifier>> include a reference to a transaction/MM procedure. There is no fixed mapping between the references/values used at both interfaces. However, during an MM-procedure/transaction there is an association/one to one relation between the value contained in the <_invokeIdentifier> and the << transaction identifier>>.

8.4.2 DECT information element to GSM information element/parameter

Table 49: DECT information element to GSM information element/parameter mapping

Item No	DECT message	GSM message	Ref.	Map Status
1	basic service	_gSMBasicService	8.4.2.1	
2	basic service	bearer capability	[18], 5.2.5.1	
3	cipher info	_gSMCipherInfo	8.4.2.1	
4	location area	_gSMLocationAreaIdentity	8.4.2.1	
5	message type	_componentType	8.4.2.3	
6		operation		
7	multi- keypad	called party number		
8	portable identity	_gSMPortableIdentity	8.4.2.1	
9	RES	_gSMRes	8.4.2.1	
10	reject reason	_RejectReason	8.4.2.1	
11	service class	_gSMServiceClass	8.4.2.1	
12	terminal capability	_gSMPortableCapabilities	8.4.2.1	
13	transaction identifier	_invokIdentifier	8.4.2.4	
NOTE 1: This table only specifies information elements/parameters that are not interworked/mapped. The handling of other information elements/parameters is defined by the respective interface protocol specifications (GAP, alpha interface).				
NOTE 2: The mapping status is included in the message interworking/mapping specifications.				

8.4.2.1 General/transparent mapping

Across the alpha interface, the GSM mobility management parameters include the corresponding DECT information elements which are defined as octet strings. The octet string received from the NT is inserted without further processing into the DECT message; there is no real interworking. However, the FT has to ensure that across the air interface the information elements are in the correct order as defined in EN 300 175-5 [6].

NOTE 1: [13] defines the order in which the parameters are transferred across the alpha interface.

NOTE 2: All of the following DECT IEs are defined as octet/bit strings: IPUI, PortableCapabilities, GSMLocationAreaIdentity, CipherKey, CipherInfo, BasicService, Res, RejectReason, Signal.

8.4.2.2 Fixed identity + location area - _gSMLocationAreaIdentity

Across the air interface the fixed identity and the location area length are transferred in two information elements. At the alpha interface however, the information is merged into one parameter; this parameter, the _gSMLocationAreaIdentity, shall contain the old PARI+RPN provided in the <<fixed identity>>, but truncated to the length corresponding to the LAL indicated in the <<location area>>.

8.4.2.3 Message type - _componentType+ _operation

Table 50: Message type - _componentType+ _operation mapping

Item No	DECT information << message type>>	GSM information <_operation>	GSM information <_componentType>	Map status	Note
1	AUTHENTICATION_REPLY	TerminalAuthentication	Return Result		
2	AUTHENTICATION_REJECT	TerminalAuthentication	Return Error		
3	CIPHER_REJECT	Ciphering	Return Error		
4	IDENTITY_REPLY	IdentityRequest	Return Result		
5	IDENTITY_REPLY	IdentityRequest	Return Error		
6	LOCATE_REQUEST	LocationRegistration	Invoke		
7	TEMPORARY-IDENTITY-ASSIGN-ACK	AssignIdentity	Return Result		note 3
8	TEMPORARY-IDENTITY-ASSIGN-ACK	LinkedAssignIdentity	Return Result		note 3
9	DETACH	Detach	Invoke		

NOTE 1: The <_componentType> defines whether the MM component concerns an invoke, a return result or reject component. The <_operation> on the other hand defines the nature of the operation e.g. location registration and/or network authentication. Across the DECT air interface, these two information fields are combined in the message type that indicated e.g. for a LOCATE-REQUEST the procedure is location registration and the type is an invoke.

NOTE 2: Similar information is contained in 8.2. Therefore, the mapping status is not repeated in this table.

NOTE 3: Whether the linked or not linked return result is used, depends on the last received invoke component.

8.4.2.4 Transaction identifier - _invokeIdentifier

The <_invokeIdentifier> and the << transaction identifier>> include a reference to a transaction/MM procedure. There is no fixed mapping between the references/values used at both interfaces. However, during an MM-procedure/transaction there is an association/one to one relation between the value contained in the <_invokeIdentifier> and the << transaction identifier>>.

Bibliography

The following material, though not specifically referenced in the body of the present document (or not publicly available), gives supporting information.

- EN 300 175-1: "Digital Enhanced Cordless Telecommunications (DECT); Common Interface (CI); Part 1: Overview".
- EN 300 175-6: "Digital Enhanced Cordless Telecommunications (DECT); Common Interface (CI); Part 6: Identities and addressing".
- EN 300 175-7: "Digital Enhanced Cordless Telecommunications (DECT); Common Interface (CI); Part 7: Security features".
- EN 300 175-8: "Digital Enhanced Cordless Telecommunications (DECT); Common Interface (CI); Part 8: Speech coding and transmission".
- TBR 6: "Digital Enhanced Cordless Telecommunications (DECT); General terminal attachment requirements".
- TBR 10: "Digital Enhanced Cordless Telecommunications (DECT); General terminal attachment requirements: Telephony applications".
- ETS 300 787: "Digital Enhanced Cordless Telecommunications (DECT); Global System for Mobile communications (GSM); Integrated Services Digital Network (ISDN); DECT access to GSM via ISDN; General description of service requirements".
- ETS 300 370: "Digital Enhanced Cordless Telecommunications (DECT); Global System for Mobile communications (GSM); DECT/GSM Interworking Profile (IWP); Access and mapping (protocol/procedure description for 3,1 kHz speech service)".
- EN 300 196: "Integrated Services Digital Network (ISDN); Generic functional protocol for the support of supplementary services; Digital Subscriber Signalling System No. one (DSS1) protocol; Part 1: Protocol specification".
- CCITT Recommendation I.130 (1988): "Method for the characterization of telecommunication services supported by an ISDN and network capabilities of an ISDN".
- EN 301 061: "Integrated Services Digital Network (ISDN); Digital Subscriber Signalling System No. 1 (DSS1) protocol; Generic functional protocol for the support of supplementary services at the "b" service entry point for Virtual Private Network (VPN) applications".
- EN 301 175: "Cordless Terminal Mobility (CTM); Phase 1; Service description".

History

Document history			
V0.0.7	March 1999	Public Enquiry	PE 9927: 1999-03-05 to 1999-07-02
V0.0.8	November 1999	Vote	V 9955: 1999-11-02 to 1999-12-31
V1.1.1	February 2000	Publication	