

Draft **EN 301 238** V1.1.1 (1997-08)

---

*European Standard (Telecommunications series)*

**Digital Enhanced Cordless Telecommunications (DECT);  
Data Services Profile (DSP);  
Isochronous data bearer services with roaming mobility  
(service type D, mobility class 2)**

---



*European Telecommunications Standards Institute*

---

---

Reference

DEN/DECT-020082 (bgo00ico.PDF)

---

Keywords

Data, DECT, GSM, profile

***ETSI Secretariat***

---

Postal address

F-06921 Sophia Antipolis Cedex - FRANCE

---

Office address

650 Route des Lucioles - Sophia Antipolis  
Valbonne - FRANCE  
Tel.: +33 4 92 94 42 00 Fax: +33 4 93 65 47 16  
Siret N° 348 623 562 00017 - NAF 742 C  
Association à but non lucratif enregistrée à la  
Sous-Préfecture de Grasse (06) N° 7803/88

---

X.400

c= fr; a=atlas; p=etsi; s=secretariat

---

Internet

secretariat@etsi.fr  
<http://www.etsi.fr>

---

***Copyright Notification***

No part may be reproduced except as authorized by written permission.  
The copyright and the foregoing restriction extend to reproduction in all media.

# Contents

Intellectual Property Rights.....	7
Foreword .....	7
1 Scope.....	8
2 Normative references .....	8
3 Definitions and abbreviations .....	10
3.1 Definitions .....	10
3.2 Abbreviations.....	10
4 Description of services.....	12
4.1 Reference configuration.....	12
4.2 Service objectives .....	13
4.2.1 General.....	13
4.2.2 32 kbit/s unprotected service.....	13
4.2.3 Unprotected rate adaptation service .....	13
5 Physical (PHL) layer requirements .....	13
6 MAC layer requirements.....	14
6.1 32 kbit/s unprotected service .....	14
6.2 Unprotected rate adaptation service.....	14
7 DLC layer requirements.....	21
7.1 C-plane requirements .....	21
7.2 U-plane requirements.....	21
7.2.1 32 kbit/s unprotected service.....	21
7.2.2 Unprotected rate adaptation service .....	21
8 NWK layer requirements .....	21
8.1 General.....	21
8.2 Requirements .....	22
9 Management entity requirements.....	22
10 Generic interworking conventions and procedures.....	23
10.1 Bit ordering.....	23
<b>Annex A (normative): LU9 - Unprotected Rate Adaptation for V series Equipment (RAVE)</b>	
<b>service .....</b>	<b>24</b>
A.1 Overview .....	24
A.1.1 FU9 frame structure .....	24
A.1.1.1 General frame structure .....	24
A.1.1.2 FU9 buffering procedures .....	25
A.1.1.3 Connection handover.....	25
A.1.1.4 Transmission order.....	25
A.2 Alignment signal management.....	26
A.2.1 General.....	26
A.2.2 Procedures .....	26
A.3 V.24 signalling .....	27
A.3.1 General.....	27
A.3.2 Transmitter procedures .....	28
A.3.3 Receiver procedures.....	28
A.4 Rate coding .....	28
A.4.1 General.....	28
A.4.2 Transmitter procedures .....	29

A.4.3	Receiver procedures.....	30
A.5	DIC.....	30
A.5.1	General.....	30
A.5.2	Measurement of phase differences.....	30
A.5.3	Compensation control rules.....	31
A.5.3.1	General.....	31
A.5.3.2	Optimizing error resilience.....	32
A.5.3.2.1	Procedure for conveying state changes.....	32
A.5.3.2.2	Procedure for executing positive and negative compensation.....	32
A.6	Information field.....	32
A.6.1	General.....	32
A.6.2	User data rates.....	33
A.6.3	Information field filling rule.....	33
A.7	Primitives.....	34
<b>Annex B (normative): Specific interworking conventions.....</b>		<b>35</b>
B.1	Interworking to connection-oriented isochronous bearer services.....	35
B.1.1	Scope.....	35
B.1.2	Reference configuration.....	35
B.1.2.1	PP.....	36
B.1.2.2	FP.....	36
B.1.2.3	General configuration.....	37
B.1.3	PP C-plane procedures.....	37
B.1.4	FP C-plane procedures.....	37
B.1.5	Network modem interworking service using V.24 connection.....	38
B.1.5.1	General.....	38
B.1.5.2	Reference configuration.....	38
B.1.5.3	TAF interworking to V.24.....	39
B.1.5.3.1	General.....	39
B.1.5.3.2	V.24 Interchange circuit handling rules.....	39
B.1.5.3.3	Call establishment signalling handling.....	39
B.1.5.3.4	Data transmission.....	39
B.1.5.4	DECT FP Interworking procedures.....	40
B.1.5.4.1	General.....	40
B.1.5.4.2	Call establishment signalling handling.....	40
B.1.5.4.3	V.24 Interchange circuit handling rules.....	41
B.1.5.4.4	Modem selection.....	41
B.1.5.4.5	Data transmission.....	41

B.2	<<IWU-ATTRIBUTES>> coding .....	44
<b>Annex C (normative):</b>	<b>Service D2; PT Profile Implementation Conformance Statement (ICS) - PHL layer.....</b>	<b>47</b>
<b>Annex D (normative):</b>	<b>Service D2; FT Profile Implementation Conformance Statement (ICS) - PHL layer.....</b>	<b>48</b>
<b>Annex E (normative):</b>	<b>Service D2; PT Profile Implementation Conformance Statement (ICS) and PT Protocol Implementation Conformance Statement (PICS) proforma - Medium Access Control (MAC) layer .....</b>	<b>49</b>
E.1	Service D2; PT Profile Implementation Conformance Statement (ICS) - Medium Access Control (MAC) layer.....	50
E.2	Service D2; PT Protocol Implementation Conformance Statement (PICS) proforma - Medium Access Control (MAC) layer .....	51
<b>Annex F (normative):</b>	<b>Service D2; FT Profile Implementation Conformance Statement (ICS) and Protocol Implementation Conformance Statement (PICS) proforma - Medium Access Control (MAC) layer .....</b>	<b>58</b>
F.1	Service D2; FT Profile Implementation Conformance Statement (ICS) - Medium Access Control (MAC) layer.....	59
F.2	Service D2; FT Protocol Implementation Conformance Statement (PICS) proforma - Medium Access Control (MAC) layer .....	60
<b>Annex G (normative):</b>	<b>Service D2; PT Profile Implementation Conformance Statement (ICS) - Data Link Control (DLC) layer.....</b>	<b>64</b>
G.1	C-plane .....	64
G.2	U-plane.....	64
G.2.1	U-plane 32 kbit/s unprotected service.....	64
G.2.2	U-plane unprotected rate adaptation service.....	64
<b>Annex H (normative):</b>	<b>Service D2; FT Profile Implementation Conformance Statement (ICS) - Data Link Control (DLC) layer.....</b>	<b>65</b>
H.1	C-plane .....	65
H.2	U-plane.....	65
H.2.1	U-plane 32 kbit/s unprotected service.....	65
H.2.2	U-plane unprotected rate adaptation service.....	65

<b>Annex J (normative):</b>	<b>Service D2; PT profile Requirement List (profile RL) and Protocol Implementation Conformance Statement (PICS) proforma - Network (NWK) layer .....</b>	<b>66</b>
J.1	Service D2; PT profile Requirement List (profile RL) - Network (NWK) layer .....	66
J.2	Service D2; PT Protocol Implementation Conformance Statement (PICS) proforma - Network (NWK) layer .....	68
<b>Annex K (normative):</b>	<b>Service D2; FT profile Requirement List (profile RL) and Protocol Implementation Conformance Statement (PICS) proforma - Network (NWK) layer .....</b>	<b>69</b>
K.1	Service D2; FT profile Requirement List (profile RL) - Network (NWK) layer .....	70
K.2	Service D2; FT Protocol Implementation Conformance Statement (PICS) proforma - Network (NWK) layer .....	71
History	.....	72

---

## Intellectual Property Rights

ETSI has not been informed of the existence of any Intellectual Property Right (IPR) which could be, or could become essential to the present document. However, pursuant to the ETSI Interim IPR Policy, no investigation, including IPR searches, has been carried out. No guarantee can be given as to the existence of any IPRs which are, or may be, or may become, essential to the present document.

---

## Foreword

This European Standard (Telecommunications series) has been produced by ETSI Project Digital Enhanced Cordless Telecommunications (DECT), and is now submitted for the Public Enquiry phase of the ETSI standards Two-step Approval Procedure (TAP).

<b>Proposed national transposition dates</b>	
Date of latest announcement of this EN (doa):	3 months after ETSI publication
Date of latest publication of new National Standard or endorsement of this EN (dop/e):	6 months after doa
Date of withdrawal of any conflicting National Standard (dow):	6 months after doa

---

# 1 Scope

The present document specifies a profile for Digital Enhanced Cordless Telecommunications (DECT) systems conforming to ETS 300 175, Parts 1 to 7 ([1] to [7]). It is part of a family of profiles aimed at the general connection of terminals supporting non-voice services to a fixed infra-structure, private and public.

The type D service, mobility class 2, as described in the ETR 185 [9] supports Isochronous Data Bearer Services (IDBSs) with mobility and is suitable for transparent transfer of isochronous data streams. It is intended for use in private and public roaming applications. Video telephony, video conferencing and secure telephone services (end-to-end encrypted) over external networks can be considered as applications of IDBS.

Phase 1 of the present document defines an unprotected service offering an unrestricted digital 32 kbit/s data bearer service, strongly based on the Generic Access Profile (GAP) (defined in ETS 300 444 [8]), and an unprotected single bearer, multi-rate, rate adaptation service to interwork to synchronous ITU Recommendations V series interfaces is also defined.

Further Phases of this profile may additionally provide multiple rate, multibearer support and limited error correction capability for services/applications requiring higher rates and high quality isochronous data transmission.

The present document specifies the requirements on the Physical (PHL) layer, Medium Access Control (MAC) layer, Data Link Control (DLC) layer and Network (NWK) layer of DECT. The present document also specifies Management Entity (ME) requirements and generic Interworking Conventions (IC).

---

# 2 Normative references

References may be made to:

- a) specific versions of publications (identified by date of publication, edition number, version number, etc.), in which case, subsequent revisions to the referenced document do not apply; or
- b) all versions up to and including the identified version (identified by "up to and including" before the version identity); or
- c) all versions subsequent to and including the identified version (identified by "onwards" following the version identity); or
- d) publications without mention of a specific version, in which case the latest version applies.

A non-specific reference to an ETS shall also be taken to refer to later versions published as an EN with the same number.

- |     |   |
|-----|---|
| [1] | ETS 300 175-1: "Digital Enhanced Cordless Telecommunications (DECT); Common Interface (CI); Part 1: Overview".                          |
| [2] | ETS 300 175-2: "Digital Enhanced Cordless Telecommunications (DECT); Common Interface (CI); Part 2: Physical layer (PHL)".              |
| [3] | ETS 300 175-3: "Digital Enhanced Cordless Telecommunications (DECT); Common Interface (CI); Part 3: Medium Access Control (MAC) layer". |
| [4] | ETS 300 175-4: "Digital Enhanced Cordless Telecommunications (DECT); Common Interface (CI); Part 4: Data Link Control (DLC) layer".     |
| [5] | ETS 300 175-5: "Digital Enhanced Cordless Telecommunications (DECT); Common Interface (CI); Part 5: Network (NWK) layer".               |
| [6] | ETS 300 175-6: "Digital Enhanced Cordless Telecommunications (DECT); Common Interface (CI); Part 6: Identities and addressing".         |



- [7] ETS 300 175-7: "Digital Enhanced Cordless Telecommunications (DECT); Common Interface (CI); Part 7: Security features".
- [8] ETS 300 444: "Digital European Cordless Telecommunications (DECT); Generic Access Profile (GAP)".
- [9] ETR 185: "Digital European Cordless Telecommunications (DECT); Data Services Profile (DSP); Profile overview".
- [10] ETR 043: "Digital Enhanced Cordless Telecommunications (DECT); Common Interface (CI); Services and facilities requirements specification".
- [11] CCITT Recommendation V.24 (1988): "List of definitions for interchange circuits between data terminal equipment (DTE) and data circuit-terminating equipment (DCE)".
- [12] ITU-T Recommendation V.34: "A modem operating at data signalling rates of up to 28 800 bit/s for use on the general switched telephone network and on leased point-to-point 2-wire telephone-type circuits".
- [13] ETS 300 474-1: "Digital Enhanced Cordless Telecommunications (DECT); Generic Access Profile (GAP); Profile requirement list and profile specific Implementation Conformance Statement (ICS) proforma; Part 1: Portable radio Termination (PT)".
- [14] ETS 300 474-2: "Digital Enhanced Cordless Telecommunications (DECT); Generic Access Profile (GAP); Profile requirement list and profile specific Implementation Conformance Statement (ICS) proforma; Part 2: Fixed radio Termination (FT)".
- [15] ETS 300 476-1: "Digital Enhanced Cordless Telecommunications (DECT); Common Interface (CI); Protocol Implementation Conformance Statement (PICS) proforma; Part 1: Network (NWK) layer - Portable radio Termination (PT)".
- [16] ETS 300 476-3: "Digital Enhanced Cordless Telecommunications (DECT); Common Interface (CI); Protocol Implementation Conformance Statement (PICS) proforma; Part 3: Medium Access Control (MAC) layer - Portable radio Termination (PT)".
- [17] ETS 300 476-4: "Digital Enhanced Cordless Telecommunications (DECT); Common Interface (CI); Protocol Implementation Conformance Statement (PICS) proforma; Part 4: Network (NWK) layer - Fixed radio Termination (FT)".
- [18] ETS 300 476-6: "Digital Enhanced Cordless Telecommunications (DECT); Common Interface (CI); Protocol Implementation Conformance Statement (PICS) proforma; Part 6: Medium Access Control (MAC) layer - Fixed radio Termination (FT)".
- [19] ITU-T Recommendation R.140: "Definitions of essential technical terms in the field of telegraph transmission".
- [20] ITU-T Recommendation V.110: "Support by an ISDN of data terminal equipments with V-Series type interfaces".

## 3 Definitions and abbreviations

### 3.1 Definitions

For the purposes of the present document, the following definitions apply:

- a) the definitions in ETS 300 444 [8]; and
- b) the following terms:

**bearer service:** A type of telecommunications service that provides the capability for the transmission of signals between user/network interfaces. For DECT systems, the Air (Radio) interface provides the bearer services between the DECT Fixed radio Termination and the DECT Portable radio Termination.

**isochronous:** Pertaining to a signal or a time-varying phenomenon characterized by significant instants separated by time intervals having a duration theoretically equal to the duration of a unit interval or to an integral multiple of this duration (ITU-T Recommendation R.140 [19]).

**mobility class 1:** Closed user groups, for which terminals are pre-registered off-air with one or more specific Fixed Parts (FP), and establishment of service and user parameters is therefore implicit, according to a profile-defined list.

**mobility class 2:** Private and public roaming applications for which terminals may move between FPs within a given domain and for which association of service parameters is explicit at the time of service request.

**service:** A set of functions offered to a user by an organization.

**synchronous:** The essential characteristics of time-scales or signals such that their corresponding significant instants occur at precisely the same average rate.

**synchronous transmission:** Transmission using isochronous signals in which the sending and receiving instruments are operating continuously in a constant time difference between corresponding significant instants (ITU-T Recommendation R.140 [19]).

### 3.2 Abbreviations

For the purposes of the present document, the following abbreviations apply:

AAL	ATM Adaptation Layer
AI	Air Interface
ATM	Asynchronous Transfer Mode
CC	Call Control
C-plane	Control plane
CRC	Cyclic Redundancy Check
Cs	higher layer signalling Channel (slow)
DCE	Data Circuit-terminating Equipment
DIC	DECT Independent Clocking
DLC	Data Link Control
DSP	Data Services Profile
DTE	Data Terminal Equipment
FP	Fixed Part
FT	Fixed radio Termination
GAP	Generic Access Profile
GSM	Global System for Mobile communication
I	higher layer Information channel
IC	Interworking Conventions
ICS	Implementation Conformance Statement
IDBS	Isochronous Data Bearer Service
IE	Information Element
ISDN	Integrated Services Digital Network

IWF	Interworking Functions
IWP	Interworking Profile
IWU	Interworking Unit
LA	Location Area
LCE	Link Control Entity
LCN	Logical Connection Number
MAC	Medium Access Control
ME	Management Entity
MM	Mobility Management
MUX	Multiplex
NWK	Network
PHL	Physical
PICS	Protocol Implementation Conformance Statement
PP	Portable Part
ppm	parts per million
PSTN	Public Switched Telephone Network
PT	Portable radio Termination
RAVE	Rate Adaption for V series Equipment
RFP	Radio Fixed Part
SAP	Service Access Point
SDU	Service Data Unit
TAF	Terminal Adaptation Functions
TDMA	Time Division Multiple Access
ULEI	U-plane Link Endpoint Identifier
U-plane	User plane

## 4 Description of services

### 4.1 Reference configuration

The reference configuration for this profile shall be as shown in figure 1.

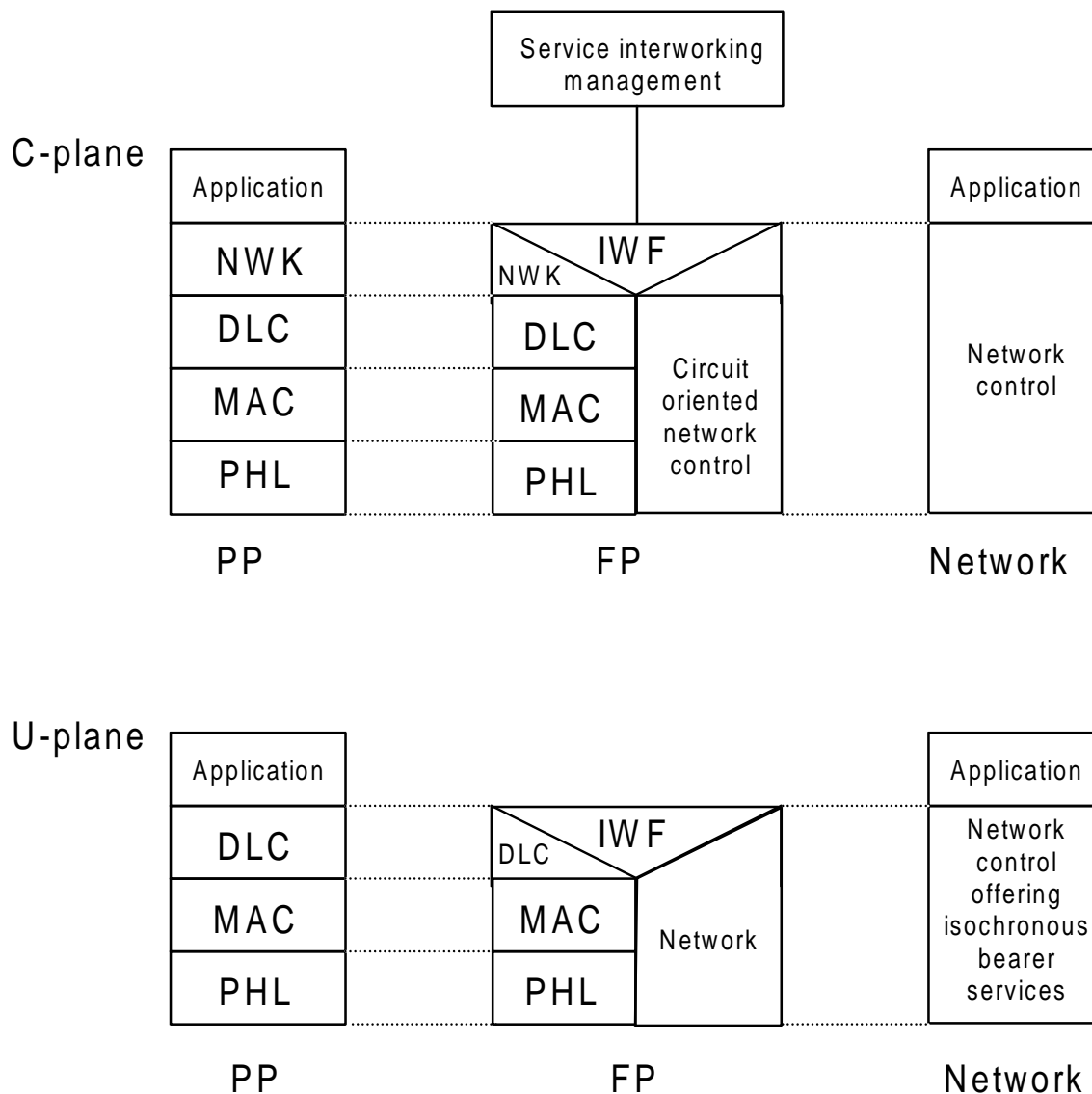

Figure 1: Profile reference configuration showing interworking to connection-oriented networks via the C-plane and U-plane

## 4.2 Service objectives

### 4.2.1 General

The service objectives for the C-plane are those of mobility class 2, described in subclause 6.2.2 of ETR 185 [9].

The service objectives for the U-plane are listed in subclauses 4.2.2 and 4.2.3.

### 4.2.2 32 kbit/s unprotected service

The U-plane service objective for the unprotected service are detailed in table 1:

**Table 1: Service objectives of the 32 kbit/s unprotected service**

Transfer mode	Circuit mode
Transfer capability	Unrestricted digital
Data structure integrity	semi-octet
Continuous data rate	32 kbit/s
User data protection	none
User data delay	10 ms
Service change and negotiation	optional
Encryption support	mandatory

### 4.2.3 Unprotected rate adaptation service

The U-plane service objective for the unprotected rate adaptation service are detailed in table 2:

**Table 2: Service objectives of the unprotected rate adaptation service**

Transfer mode	Circuit mode
Transfer capability	Unrestricted digital
Data structure integrity	octet
Continuous data rate	by steps of 2,4 kbit/s up to 28,8 kbit/s; and by steps of 4 kbit/s up to 28,0 kbit/s
User data protection	none
User data delay	15 ms
Service change and negotiation	optional
Encryption support	mandatory
Network independent clocking	supported
In band rate changes	supported
V.24 control signalling	optional
Asymmetric rates	supported

---

## 5 Physical (PHL) layer requirements

The requirements of the GAP, defined in ETS 300 444 [8], clause 11 shall apply, with the following exception:

- in subclause 11.1, the sentence "To carry the speech information, full slots shall be used" shall be replaced by "Full slots shall be used".

## 6 MAC layer requirements

For both the services, the following shall apply:

- a) bit a12 of the Fixed Part Capabilities message (defined in ETS 300 175-3 [3], subclause 7.2.3.4) shall be set to 1; and
- b) the MAC Extended Fixed Part Capabilities message (defined in ETS 300 175-3 [3], subclause 7.2.3.5) shall be used and bit a44 of Extended capabilities field shall be set to 1.

NOTE: The Extended Fixed Part Capabilities message is broadcast by a FP to indicate the support of the D profile.

### 6.1 32 kbit/s unprotected service

The requirements of the GAP, defined in ETS 300 444 [8], clause 10 shall apply.

### 6.2 Unprotected rate adaptation service

The requirements of GAP, defined in ETS 300 444 [8], clause 10 shall apply, with the following additions/variations (a to j):

- a) replace subclause 10.1 with the following text:

#### 10.1 General

The FT and PT shall support In\_normal\_delay service as defined in ETS 300 175-3 [3], subclause 10.8.3.2.

The FT and PT shall support frame format as follows:

- full slot mode defined in ETS 300 175-3 [3], subclause 4.2.2;
- D-field mapping shall support the D-00 and D32 as defined in ETS 300 175-3 [3], subclause 6.2.1.1.

The FT and PT shall support A-field mapping A-MAP.

The FT and PT shall understand all A field tail identifications (a0, a1 and a2) in the header field as defined in ETS 300 175-3 [3], subclauses 6.2.1.2 and 7.1.2.

The FT and PT shall support the following B-field field identifications (a4, a5 and a6) as defined in ETS 300 175-3 [3], subclause 7.1.4:

- U-type: In, "000"B;
- no B-field, "111" B (shall only be used for dummy bearers).

The FT and PT shall support T-MUX as defined in ETS 300 175-3 [3], subclause 6.2.2.1.

The FT and PT shall support B-field multiplex E/U MUX type U32a.

The FT and PT shall support scrambling as defined in ETS 300 175-3 [3], subclause 6.2.4.

The FT and PT shall provide R-CRC generation and checking as defined in ETS 300 175-3 [3], subclause 6.2.5.2. The FT and PT shall provide X-CRC generation and checking as defined in ETS 300 175-3 [3], subclauses 6.2.5.3 and 6.2.5.4.

The PT shall support the normal duty cycle idle\_locked mode as defined in ETS 300 175-3 [3], subclauses 11.3 and 4.3.1.

The FT and PT shall support primary scan procedure as defined in ETS 300 175-3 [3], subclause 11.8.

b) replace subclause 10.2.3 with the following text:

### 10.2.3 Qt - FP capabilities

If the bit a33 in higher layer capabilities (see table 102) is set to value "1", the PT may assume the values as indicated in table 91 to be set to value "1". The FT shall set the respective values to "1".

**Table 91: Values used within FP capabilities**

MAC message	Field within the message	Standard values within the MAC message	Normative action/comment
<<FP capabilities>>			
	<QH>	3	
	<a12>	1	extended FP info
	<a17>	1	Full slot
	<a24>	1	Advanced A-field set-up
	<a28>	1	In normal delay

**Higher layer information:** the management entity in the FP supplies the MAC layer with a 16 bit SDU via the Management Entity (ME) SAP. At the PT the MAC layer passes the 16 bits out through the ME SAP to the management entity.

For the setting of the higher layer information bits see subclause 13.6.

c) add the following new subclause 10.2.5 with the following text:

### 10.2.5 Qt - Extended FP capabilities

The procedure shall be performed as defined in subclauses 7.2.3.5 and 7.2.3.1 of ETS 300 175-3 [3].

**Table 92a: Values used within Extended FP capabilities**

MAC message	Field within the message	Standard values within the MAC message	Normative action/comment
<<Extended FP capabilities>>			
	<QH>	4	
	<a44>	1	D profile

d) replace subclause 10.4 with the following text:

#### 10.4 Set-up of advanced connection, A-field advanced bearer set-up

The procedure shall be performed as defined in ETS 300 175-3 [3], subclauses 10.2.4.2 and 10.5.1.2.

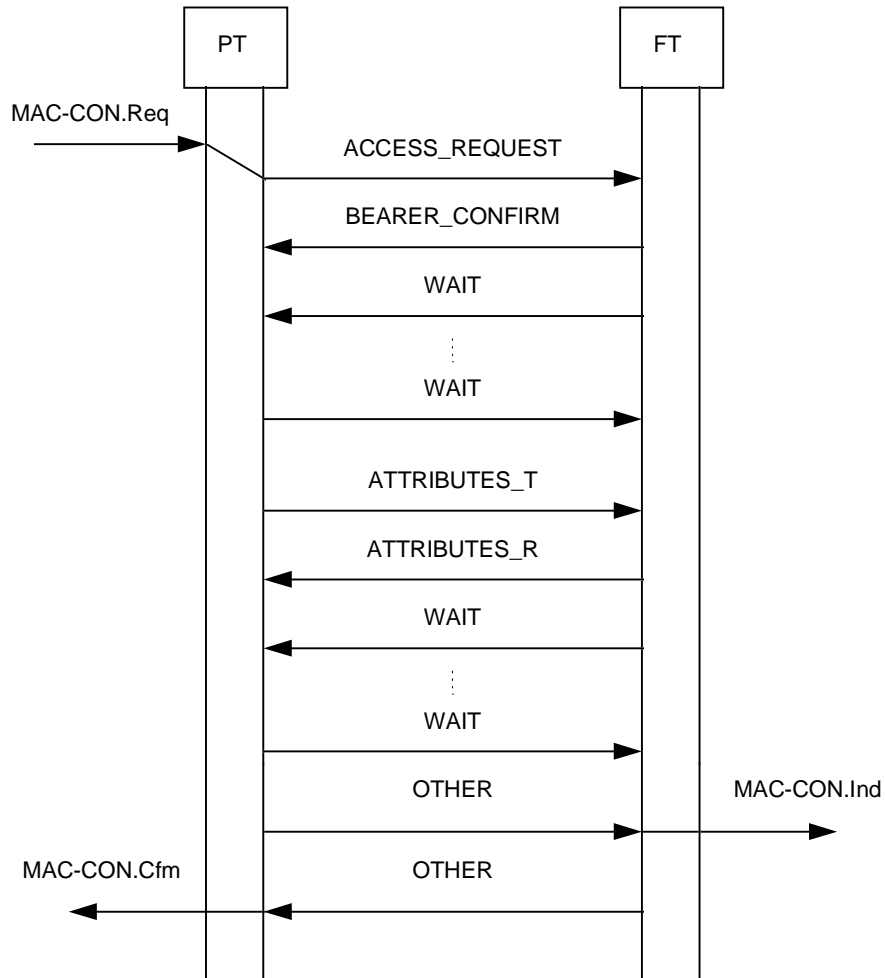

Figure 2: Set-up of advanced connection and bearer



e) replace subclause 10.4.1 with the following text:

#### 10.4.1 Mt message

The following fields as defined in ETS 300 175-3 [3], subclause 7.2.5.3 of in the MAC control (Mt) message shall be supported by the PT and the FT.

**Table 95: Values used within Mt message**

MAC message	Field within the message	Standard values within the MAC message	Normative action/comment
<<Mt message>>			
	<Mt header>	1	"Advanced connection control".
	<Command>	0	"Access_request"
		4	"Bearer_confirm"
		5	"Wait"
	<FMID>	All	
	<PMID>	All	See subclause 13.4.

**Table 95a: Values used within Mt message**

MAC message	Field within the message	Standard values within the MAC message	Normative action/comment
<<Mt message>>			
	<Mt header>	1	"Advanced connection control".
	<Command>	6	"Attributes_T.Req"
		7	"Attributes_T.Cfm"
	<ECN>	All	
	<LBN>	15	
	<up/down/sm/ss>	3	
	<ser type>	1	
	<max life>	0	
	<slot type>	0	
	<CF>	0	
	<FMID>	All	
	<PMID>	All	See subclause 13.4.

f) replace subclause 10.5.1 with the following text:

### 10.5.1 Mt message

The following fields as defined in ETS 300 175-3 [3], subclause 7.2.5.3 in the MAC control (Mt) message shall be supported by the PT and the FT.

**Table 96: Values used within Mt message**

MAC message	Field within the message	Standard values within the MAC message	Normative action/comment
<<Mt message>>			
	<Mt header>	1	"Advanced connection control".
	<Command>	0	"Release"
	<spr>	0	
	<LBN>	15	
	<PMID>	All	See subclause 13.4.

g) replace subclause 10.6 with the following text:

### 10.6 Bearer handover request

The procedure shall be performed as defined in ETS 300 175-3 [3], subclauses 10.6.2 and 10.5.1.2.

The procedure is equivalent for intra- and inter-cell handover.

The FT should not release the old bearer within 10 ms after the establishment of the new bearer.

h) replace subclause 10.6.1 with the following text:

### 10.6.1 Mt message

The following fields as defined in ETS 300 175-3 [3], subclause 7.2.5.3 in the MAC control (Mt ) message shall be supported by the PT and the FT.

**Table 97: Values used within Mt message**

MAC message	Field within the message	Standard values within the MAC message	Normative action/comment
<<Mt message>>			
	<Mt header>	1	"Advanced connection control".
	<Command>	1	"Bearer_handover_request".
		4	"Bearer_confirm"
		5	"Wait"
	<FMID>	All	
	<PMID>	All	See subclause 13.4.

**Table 97a: Values used within Mt message**

MAC message	Field within the message	Standard values within the MAC message	Normative action/comment
<<Mt message>>			
	<Mt header>	1	"Advanced connection control".
	<Command>	6	"Attributes_T.Req"
		7	"Attributes_T.Cfm"
	<ECN>	All	
	<LBN>	15	
	<up/down/sm/ss>	3	
	<ser type>	1	
	<max life>	0	
	<slot type>	0	
	<CF>	0	
	<FMID>	All	
	<PMID>	All	See subclause 13.4.

i) replace subclause 10.7 with the following text:

### 10.7 Connection handover request

The procedure shall be performed as defined in ETS 300 175-3 [3], subclauses 10.2.4.2 and 10.5.1.2.

The procedure is equivalent for intra- and inter-cell handover.

j) replace subclause 10.7.1 with the following text:

### 10.7.1 Mt message

The following fields as defined in ETS 300 175-3 [3], subclause 7.2.5.2 in the MAC control (Mt ) message shall be supported by the PT and the FT.

**Table 98: Values used within Mt message**

MAC message	Field within the message	Standard values within the MAC message	Normative action/comment
<<Mt message>>			
	<Mt header>	1	"Advanced connection control".
	<Command>	2	"Connection_handover_request".
		4	"Bearer_confirm"
		5	"Wait"
	<FMID>	All	
	<PMID>	All	See subclause 13.4.

**Table 98a: Values used within Mt message**

MAC message	Field within the message	Standard values within the MAC message	Normative action/comment
<<Mt message>>			
	<Mt header>	1	"Advanced connection control".
	<Command>	6	"Attributes_T.Req"
		7	"Attributes_T.Cfm"
	<ECN>	All	
	<LBN>	15	
	<up/down/sm/ss>	3	
	<ser type>	1	
	<max life>	0	
	<slot type>	0	
	<CF>	0	
	<FMID>	All	
	<PMID>	All	See subclause 13.4.

---

## 7 DLC layer requirements

The DLC layer shall contain two independent planes of protocol: the C-plane and the U-plane. All internal DECT protocol control shall be handled by the C-plane. All external user data and control shall be handled by the U-plane.

### 7.1 C-plane requirements

The requirements of the GAP, defined in ETS 300 444 [8], from subclause 9.1 to 9.8 inclusive shall apply.

### 7.2 U-plane requirements

#### 7.2.1 32 kbit/s unprotected service

The requirements of the GAP, defined in ETS 300 444 [8], subclauses 9.9 and 9.10 shall apply.

#### 7.2.2 Unprotected rate adaptation service

The requirements described in annex A (LU9 - Unprotected Rate Adaption for V series Equipment (RAVE) service) of the present document shall apply.

---

## 8 NWK layer requirements

### 8.1 General

The NWK layer provisions shall include the following entities:

- Call Control (CC);
- Link Control Entity (LCE);
- Mobility Management (MM).

Portable Part and Fixed Part CC entities shall use circuit switched mode procedures.

Annex B specifies how procedures shall be used.

The MM requirements shall be aligned to the requirements of the GAP, defined in ETS 300 444 [8].

The provisions of NWK layer, ETS 300 175-5 [5] shall be implemented with respect to the services, procedures, messages and information elements coding listed in annexes B, I and L. The provisions of ETS 300 175-6 [6] shall be implemented with respect to the structure and use of identities.

The Extended Higher Layer Fixed Part Information field shall be used with bit a44 set to 1, indicating the support of the D profile.

Support for exchanged attribute procedures shall be mandatory (ETS 300 175-5 [5], subclause 15.2.3).

The <<RELEASE-REASON>> element shall always be included in the {CC-RELEASE-COM} message.

## 8.2 Requirements

The full requirements of the GAP, defined in ETS 300 444 [8] clause 8 shall apply, with the following exceptions and/or additions:

- a) both PP and FP shall set the info element <<BASIC SERVICE>> (defined in ETS 300 175-5 [5], subclause 7.6.4) to " Other" value;
- b) both PP and FP shall support the information element <<IWU-ATTRIBUTES>>, (defined in ETS 300 175-5 [5], subclause 7.7.21);
- c) both PP and FP shall support the information element <<RELEASE-REASON>> (defined in ETS 300 175-5 [5], subclause 7.6.7).

The specific coding required for the <<IWU-ATTRIBUTES>> information element is defined in clause B.2 of the present document.

---

## 9 Management entity requirements

The management entity shall be responsible for maintenance and updating of the logical associations between NWK, DLC, MAC and U-plane entities and shall contain the following procedure groups defined in ETS 300 175-4 [4]:

- MAC connection management;
- DLC C-Plane management;
- DLC U-Plane management.

The requirements of mobility class 2 shall be met by the management procedures defined in ETS 300 444 [8] with the following exception:

### 13.6 Broadcast attributes management

RFPs belonging to the same LA shall broadcast the same values of higher layer attributes (see ETS 300 175-5 [5], annex F) at any given time.

The PP shall be capable to read and interpret at least the following broadcast attributes codings during locking procedure. In the locked state the PP may assume them as static.

**Table 102: Fixed Part Capabilities Broadcast attributes interpretation by the PP  
(see ETS 300 175-5 [5], clause F.1)**

Bit number	Attribute	Value	Note
a34	Non-voice circuit switched service	All	
a36	Standard authentication required	All	
a37	Standard ciphering supported	All	
a38	Location registration supported	All	
a44	Access rights requests supported	All	
a46	Connection handover supported	All	

**Table 102a: Extended Fixed Part Capabilities Broadcast attributes interpretation by the PP  
(see ETS 300 175-5 [5], clause F.2)**

Bit number	Attribute	Value	Note
a44	Data service profile D	All	

---

## 10 Generic interworking conventions and procedures

### 10.1 Bit ordering

In order to interwork with other different networks, the data stream in the U-plane shall respect the bit ordering rule described in ETS 300 175-3 [3], subclause 5.4.5. For simplicity, the same subclause is reproduced below.

#### **5.4.5 Order of transmission**

Certain primitives exchanged between the MAC layer and the DLC layer may have a SDU containing peer-to-peer messages. The Service Data Unit (SDU) data is arranged as a list of octets or part octets, starting with octet 1. The bits within one octet are numbered from 1 to 8 where the most significant bit has number 8. The MAC layer transmits these octets in ascending order, starting with octet 1. Valid bits within one octet are transmitted in descending order.

The same bit ordering shall be maintained at the interface between the DECT DLC U-plane and the IWU in the FP. The same bit ordering shall be maintained at the interface between the DECT DLC U-plane and the Terminal Adaptation Functions (TAF) in the PP.

# Annex A (normative):

## LU9 - Unprotected Rate Adaptation for V series Equipment (RAVE) service

### A.1 Overview

The LU9 service provides for the transparent transport of synchronous continuous data at rates suitable for data terminal equipment with V series interfaces. Specific support for low speed Asynchronous Transfer Mode (ATM) Adaptation Layer - 1 (AAL-1) rates is also provided.

The unprotected service offers no error correction of user data and no notification of errors. It therefore offers a simple, easily implemented service for applications where a higher level of bit errors can be accepted. The unprotected service shall use U-DLC transmission class 0.

The protected service is left for further study.

LU9 shall provide mechanisms that offer unprotected reliable transport of isochronous data and reliable transport of LU9 control signalling. Five main procedures shall be provided:

- 1) filtering period indication;
- 2) transfer of V.24 signalling;
- 3) rate indication;
- 4) DECT Independent Clocking (DIC);
- 5) user data transfer.

Each instance of LU9 shall be distinguished by the use of a different Logical Connection Number (LCN).

#### A.1.1 FU9 frame structure

##### A.1.1.1 General frame structure

The FU9 frame is a fixed length fragmentation.

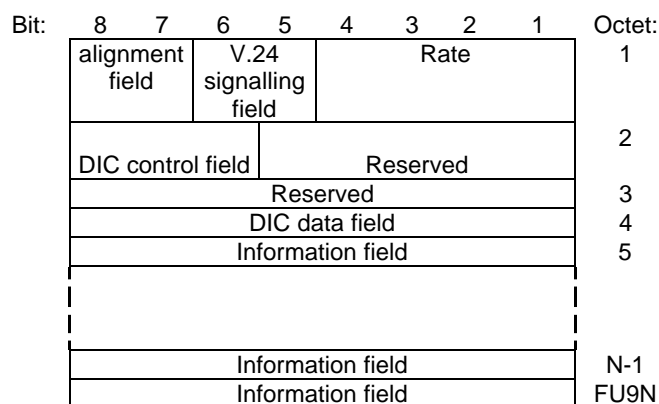

**Figure A.1: Frame format type FU9**



FU9 is a function of the underlying connection type:

**Table10: FU9 connection types**

Connection type	Slot type	FU9
I <sub>N</sub> / normal delay	Full slot	40 octets

Other connection types are for further study.

### A.1.1.2 FU9 buffering procedures

The FU9 entity shall be used to provide a data buffering function between the service user and the MAC layer. It shall be required to supply data to the MAC layer (at the transmit side) or accept data from the MAC layer (at the receive side) on demand and with minimum delay.

NOTE: Normal data delivery will be periodic, with frames demanded and delivered at the Time Division Multiple Access (TDMA) frame rate.

Transmit side: on receipt of a MAC\_CO\_DTR-ind primitive, one complete frame of data shall be submitted to the MAC layer in a MAC\_CO\_DATA-req primitive.

Receive side: each MAC\_CO\_DATA-ind primitive shall contain one complete frame of data from the MAC layer.

Data overflow or underflow due to slight clock differences shall be handled by the DIC procedures described in clause A.5.

### A.1.1.3 Connection handover

During connection handover, FU9 frames may be sent simultaneously to both the old and the new connections. The receive path is then switched to the new connection as soon as the new connection is indicated to be in the "open" state.

NOTE: Dependent upon the exact implementation of both Fixed radio Termination (FT) and Portable radio Termination (PT), seamless connection handover should be possible.

### A.1.1.4 Transmission order

The physical transmission order shall be controlled by the MAC layer as defined in subclause 10.1 of this profile. This MAC layer ordering shall use the octet numbering and bit numbering described in clause 10.

The operations across the DLC layer/MAC layer boundary shall be such that the DLC entity sending a frame can assume this temporal order of the frame, and that the entity receiving the frame can reconstruct it with its assumed temporal order.

In all cases, the order of arrival of the higher layer information shall be preserved, and this shall be identical to the order of transmission.

## A.2 Alignment signal management

### A.2.1 General

For the information carried in the V.24 signalling field, in the Rate field, in the DIC control and in the DIC data field, a "filtering period" equal to 10 successive FU9 frames is defined.

The filtering period duration is associated to the transmission of a special codeword, called alignment signal, in the bit 1 and bit 2 in octet 1.

The alignment signals shall be continuously transmitted: in this way, the last frame of filtering period numbered N and the first frame of filtering period numbered N+1 shall be consecutive.

To reduce errors due to the hostile nature of the radio channel, the same DIC information shall be maintained constant at least in one filtering period. The V.24 signalling and Rate information shall be maintained constant at least in two consecutive filtering periods.

Furthermore, changes of values shall be possible only at the beginning of a filtering period. At the receiver side, these variations shall be considered valid only if the receiver is in the locked state.

For the alignment signal management, the procedures described in subclause A.2.2 shall apply.

NOTE: The alignment signal emulates a "square wave" signal. The filtering period is equivalent to the period of the "square wave".

### A.2.2 Procedures

**Transmitter side:** the transmitter shall set bit 1 and bit 2 in octet 1 in the FU9 frames constituting the alignment signal in accordance with table 11.

**Table 11: Alignment field coding**

Frame number	bit 1 octet 1	bit 2 octet 1
N	1	1
N+1	1	1
N+2	1	1
N+3	1	1
N+4	1	1
N+5	0	0
N+6	0	0
N+7	0	0
N+8	0	0
N+9	0	0

NOTE: The first frame of the filtering period in table 11 is frame number N. The last frame of the filtering period in table 11 is frame number N+9. The possible new value in the V.24 signalling field, in the Rate field, in the DIC control field and in the DIC data field shall be inserted starting from frame N.

**Receiver side:** the receiver shall operate in one of two possible states: the "unlocked" state and the "locked" state (see figure A.2).

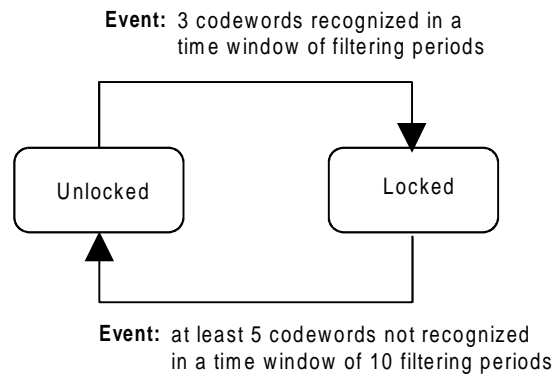

**Figure A.2: Receiver side states**

In the unlocked state, the receiver shall continuously monitor the status of bit 1 and bit 2 in octet 1 in consecutive received FU9 frames, trying to recognize the alignment signal bit pattern. The receiver shall enter the locked state only if it shall be able to recognize at least 3 alignment signals in a time window of 5 filtering periods (equal to 50 FU9 frames).

In the locked state, the receiver shall continuously monitor the status of bit 1 and bit 2 in consecutive received FU9 frames, trying to recognize the alignment signal bit pattern. The receiver shall enter the unlocked state only if it shall not be able to recognize at least 5 alignment signals in a time window of 10 filtering periods (equal to 100 FU9 frames).

The initial state at the receiver side shall be the unlocked state.

## A.3 V.24 signalling

### A.3.1 General

Bits 5 and 6 of octet 1 in FU9 frame shall be used for V.24 signalling transfer, in the FP⇒PP direction only. In the opposite direction (PP⇒FP), these bits shall be permanently set to 1.

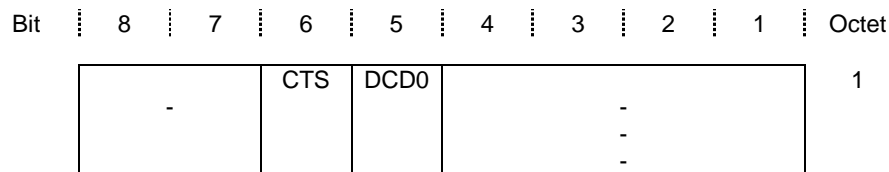

Bit 5 and bit 6 of octet 1 shall be coded as follows:

#### CTS (octet 1):

Bits	6	Meaning
0		CTS line (circuit 106) OFF
1		CTS line (circuit 106) ON

#### DCD (octet 1):

Bits	5	Meaning
0		DCD line (circuit 109) OFF
1		DCD line (circuit 109) ON

## A.3.2 Transmitter procedures

The Interworking Functions (IWF) in the FP shall transfer the status of circuit 106 (CTS) and 109 (DCD) from the V series interface (see CCITT Recommendation V.24 [11]) to the TAF in the PP in the octet 1 of an FU9 frame. The individual current status of each circuit shall be maintained for all the FU9 frames of at least two consecutive filtering periods (see subclause A.2.1). Individual status transitions of each circuit shall be transferred only from the first frame of a filtering period.

## A.3.3 Receiver procedures

The TAF in the PP shall determine the status of circuit 106 (CTS) and 109 (DCD) by integration of the relevant bits of FU9 frames belonging to two consecutive filtering periods. The following integration rules shall apply:

- a) in a filtering period, the result of the integration shall be the value chosen with majority (at least 6 repetitions on the 10 possible ones). In the event that an equal number (5) of each value is detected the current value shall be maintained;
- b) a new status shall be considered valid only if two consecutive filtering periods present the same integration result and the receiver state is "locked" (see clause A.2).

---

## A.4 Rate coding

### A.4.1 General

Bits 1 to 4 of octet 1 in FU9 frame shall be used to signal user data rate. This indication is complementary to the user data rate indication already transferred in the C-plane (see clause B.2) which indicates a minimum and maximum rate. This in-band indication can be used for dynamic in-band, in-call rate changes between the indicated C-plane minimum and maximum rates. The in-band rate indication also facilitates the synchronization of the rate indication change with the corresponding change in the number of user data octets in the LU9 information field, see subclauses A.4.2, A.4.3 and clause A.6.

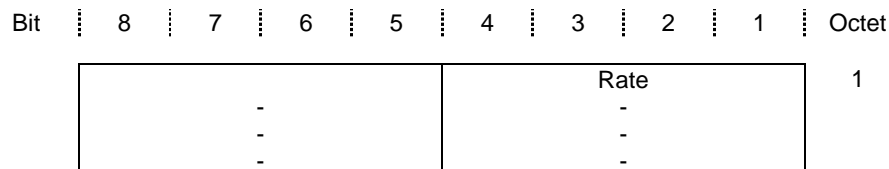

Valid codings of bits 1 to 4 of octet 1 in FU9 frames shall be the following:

If the user data rate resolution (bits 3-4, octet 6) of the <<IWU-ATTRIBUTES>> Information Element (IE) (see clause B.2) indicates " $n \times 2,4$  kbit/s" then:

**Rate (octet 1):**

Bits	4 3 2 1	Meaning
	0 0 0 0	0 kbit/s
	0 0 0 1	2,4 kbit/s
	0 0 1 0	4,8 kbit/s
	0 0 1 1	7,2 kbit/s
	0 1 0 0	9,6 kbit/s
	0 1 0 1	12 kbit/s
	0 1 1 0	14,4 kbit/s
	0 1 1 1	16,8 kbit/s
	1 0 0 0	19,2 kbit/s
	1 0 0 1	21,6 kbit/s
	1 0 1 0	24 kbit/s
	1 0 1 1	26,4 kbit/s
	1 1 0 0	28,8 kbit/s
	All other values reserved.	

If the user data rate resolution (bits 3-4, octet 6) of the <<IWU-ATTRIBUTES>> IE (see clause B.2) indicates " $n \times 4$  kbit/s" then:

**Rate (octet 1):**

Bits	4 3 2 1	Meaning
	0 0 0 0	0 kbit/s
	0 0 0 1	4 kbit/s
	0 0 1 0	8 kbit/s
	0 0 1 1	12 kbit/s
	0 1 0 0	16 kbit/s
	0 1 0 1	20 kbit/s
	0 1 1 0	24 kbit/s
	0 1 1 1	28 kbit/s
	All other values reserved.	

## A.4.2 Transmitter procedures

The IWF in the FP shall submit a DLU-LU9\_RATE.req (containing the new data rate) to the LU9 entity in the FP side. The LU9 entity shall set the Rate field accordingly. The Rate field status shall be maintained for all the FU9 frames of two filtering periods at least (see subclause A.2.1). Rate field status changes shall be possible only at the beginning of the same filtering period at which an OFF to ON status transition for the CTS signal takes place (see clause A.3).

The new user data rate shall only take effect (according to the information field specification of clause A.6) from the first frame after the first 2 filtering periods which signalled the change.

### A.4.3 Receiver procedures

The LU9 entity in the PP shall determine the data rate value by integration of bits 1 to 4 of octet 1 of FU9 frames belonging to two consecutive filtering periods. The following integration rules shall apply:

- a) in a filtering period, the result of the integration shall be the value chosen with majority (at least 6 repetitions on the 10 possible ones);
- b) the status shall be considered valid only if two consecutive filtering periods present the same integration result and the receiver state is "locked" (see clause A.2).

If condition a) and b) are matched, a DL-LU9\_RATE.ind primitive, containing the data rate value, shall be submitted to the upper layer by the LU9 entity in the PP. The information field from the first frame of next filtering period shall be interpreted according to the new user data rate and as specified in clause A.6.

---

## A.5 DIC

### A.5.1 General

In cases where isochronous data streams at user rates up to and including 28,8 kbit/s are received from a remote data source, the data will usually not be synchronized with the DECT clock. For example, the data may be received through an interworking unit from voice-band modems on the analogue Public Switched Telephone Network (PSTN) where the transmit data from the remote modem is synchronized to the modem clock. The frequency tolerance of such modems is generally 100 parts per million (ppm). Another example is the case where a stream of data octets is received from the Integrated Services Digital Network (ISDN) and the DECT clock is not synchronized with the ISDN clock.

The following method shall be used to enable transfer of those data signals and the corresponding (octet) timing information across the DECT air interface.

### A.5.2 Measurement of phase differences

The user data is treated as a stream of octets. If the data source provides octet timing, octet integrity is preserved. If the data source does not provide octet timing, received bits are still treated as octets by grouping them together in 8 bit groups.

The phase difference between the following two frequencies will be measured:

- R1 = user data rate in octets/s synchronized with the DECT clock;
- R2 = user data rate in octets/s synchronized with the data source clock (e.g. modem).

Figure A.3 shows the phase diagram for this phase difference (phase (R2) - phase (R1)). Table 12 shows the related bit coding of the DIC control field.

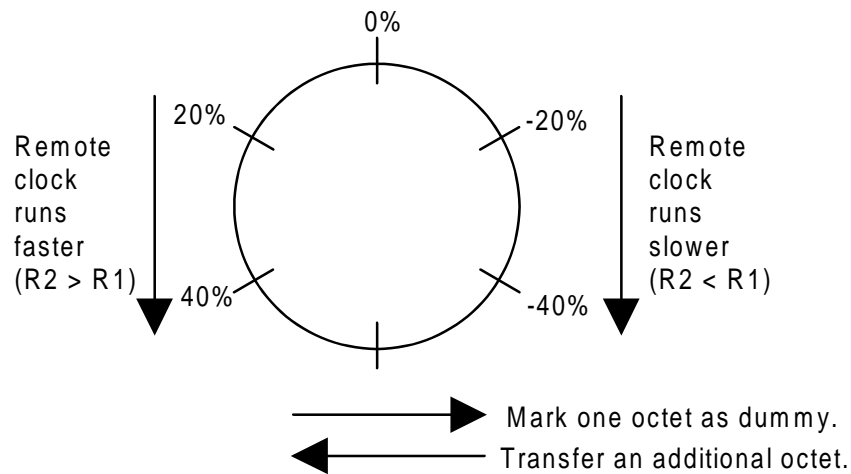

Figure A.3: Phases diagram

Table 12: Phase differences coding

Displacement	Coding DIC control field (octet 2)		
	bit 8	bit 7	bit 6
0 %	1	0	0
+20 %	0	1	1
+40 %	0	0	0
-40 %	1	1	1
-20 %	0	1	0

## A.5.3 Compensation control rules

### A.5.3.1 General

The initial state at both transmitting and receiving state is 0 %. Without compensation, the number of conveyed user data octets per frame is N.

Positive compensation:

On transition from +40 % to -40 %, one frame will convey N+1 user data octets.

(Details: see subclause A.5.3.2)

Negative compensation:

On transition from -40 % to +40 % one frame will convey N-1 user data octets.

(Details: see subclause A.5.3.2)

Hysteresis:

To avoid continuous jitter between neighbouring displacement positions, the displacement code shall be changed only when the measured phase difference is 15 % more or less than the difference indicated by the existing displacement code.

**EXAMPLE:** Bit combination '011' indicates a phase difference of nominally 20 %. This bit combination will be changed into '000' when the measured phase difference is 35 % or more, and into '100' when the measured phase difference is 5 % or less.

### A.5.3.2 Optimizing error resilience

Transmission errors may hit the DIC control field and may therefore cause malfunctioning of the DIC mechanism. In order to optimize resilience against transmission errors the additional rules described in subclause A.5.3.2.1 and subclause A.5.3.2.2 shall apply.

#### A.5.3.2.1 Procedure for conveying state changes

**Transmitter rules:**

Within one filtering period, the DIC control fields of all frames shall indicate the same displacement value. As a consequence state changes can only occur once per filtering period.

Only state changes between adjacent states are allowed.

**Receiver rules:**

At the end of any received filtering period, the receiver shall examine the contents of the DIC control fields of all frames within that filtering period:

- if at least 6 of the 10 frames included in a filtering period contain the same DIC control field value, that value is accepted. Otherwise the old state value is maintained;
- if the accepted DIC control field value indicates a state change to a non adjacent state, the state is chosen which is adjacent and located in the appropriate direction.

#### A.5.3.2.2 Procedure for executing positive and negative compensation

**Positive compensation:**

The first frame of a filtering period, directly following a filtering period indicating a state change from +40 % to -40 %, shall convey N+1 user data octets, i.e. one octet in the DIC data field, followed by N octets in the user data field.

**Negative compensation:**

The first frame of a filtering period, directly following a filtering period indicating a state change from -40 % to +40 %, shall convey N-1 user data octets in the user data field.

The value of N is specified in subclause A.6.2, table 13 relative to the user data rate.

NOTE 1: The present document is based on a similar (but not identical) mechanism specified in ITU-T Recommendation V.110 [20].

NOTE 2: It is assumed that for DIC management, each frame carries two fields:

- a DIC control field of 3 bits and a DIC data field of 8 bits;
- in the FU9 frame, these are, respectively, octet 2, bits 8-7-6 and octet 4.

---

## A.6 Information field

### A.6.1 General

Octets 5 to 40 in FU9 frame shall be used for user data transfer.

The rules regarding the in-band signalling of the user data rate, and in particular when the rate changes take effect with respect to the filtering periods, shall apply as specified in clause A.4.



## A.6.2 User data rates

Different data rates are allowed, from 2,4 kbit/s up to 28,8 kbit/s, by steps of 2,4 kbit/s or 4 kbit/s. The user data rate values and the number of octets required in a FU9 frame are listed in table 13.

**Table 13: Octets required in the Information field**

User data rates (kbit/s)	Octets required
0	0
2,4	3
4,8	6
7,2	9
9,6	12
12	15
14,4	18
16,8	21
19,2	24
21,4	27
24	30
26,4	33
28,8	36
4	5
8	10
12	15
16	20
20	25
24	30
28	35

## A.6.3 Information field filling rule

At the transmission side, user data shall be submitted to the LU9 transmitting entity with a DL-U\_DATA-req (ETS 300 175-4 [4], subclause 8.4.2.1). User data shall occupy part or all of the Information field, depending on the user data rate defined in the Rate field (see clause A.4).

To map the user data in the Information field, the following rules shall apply:

- a) the first user data octet shall be octet 5, unless section e) of this subclause applies;
- b) the following transmitted user data octets shall occupy the following successive octets;
- c) the number of occupied octets (indicated as M) shall respect the values listed in table 13, with the exception of cases d) and e);
- d) if a DIC negative compensation (see subclause A.5.3.2.2) is required, octet 5 shall be filled with '0' Hexadecimal. Only in this case, the first user data octet shall be octet 6. The M-1 octets used to carry the user data shall be octets 6 to octet M+4 inclusive;
- e) if a DIC positive compensation (see subclause A.5.3.2.1) is required, octet 4 shall be filled with the first transmitted user data octet. Only in this case, the first user data octet shall be octet 4. The M-1 octets used to carry the user data shall be octets 4 to octet M+4 inclusive;
- f) If the user data rate is less or equal to 9,6 kbit/s, the first M octets group (starting at octet 5) shall be repeated in the remaining Information field octets, respecting the octet order; otherwise
- g) if the user data rate is greater than 9,6 kbit/s, the remaining octets shall be filled with '0' Hexadecimal.

NOTE: Condition f) may be used, at the receiving side, in the TAF (PP side) or the IWF (FP side) to correct the errors introduced by the radio transmission.

## A.7 Primitives

User data shall be transferred between LU9 and the LU9-SAP using the DL-U\_DATA primitive defined in ETS 300 175-4 [4], subclause 8.4.2.1. In addition, the following primitives have been defined for LU9 operation:

DLU-LU9\_RATE{req, ind}

Parameter	REQ	CFM	IND	RES
U-plane Link Endpoint Identifier (ULEI)	A/N		A/N	
Rate indication	A/N		A/N	
A: Always; O: Optional; N: Not allowed.				

NOTE 1: The DLU-LU9\_RATE.req primitive is used only in the FP.  
The DLU-LU9\_RATE.ind primitive is used only in the PP.

DLU-LU9\_CTRL{req, ind}

Parameter	REQ	CFM	IND	RES
U-plane Link Endpoint Identifier (ULEI)	A/N		A/N	
V.24 Data not ready				
V.24 control octet	A/N		A/N	
A: Always; O: Optional; N: Not allowed.				

NOTE 2: The DLU-LU9\_RATE.req primitive is used only in the FP.  
The DLU-LU9\_RATE.ind primitive is used only in the PP.

NOTE 3: These primitives are defined only for the purpose of describing layer-to-layer interactions. The primitives are defined as an abstract list of parameters, and their concrete realization may vary between implementations. No formal testing of primitives is intended.

## Annex B (normative): Specific interworking conventions

### B.1 Interworking to connection-oriented isochronous bearer services

#### B.1.1 Scope

The provisions of this subclause shall apply to interworking to public connection-oriented isochronous network services. Interworking to ITU-T V series synchronous modems (e.g. V.34) and ITU-T Recommendation V.110 [20] are examples of this type of applications. For the purposes of this interworking annex, only full duplex transmissions are to be supported.

The physical implementation of these services and the use of the IWF to other networks (if present) are abstracted from the user. The PP user sees a standardized wireless service which is functionally equivalent to interfacing to an auto-calling/answering Data Circuit-terminating Equipment (DCE) accessing a connection-oriented isochronous bearer service (such as modem). In addition the service also provide the security (authentication of PT and encryption, FT activated) as used in the GAP (ETS 300 444 [8]), making it suitable for public wireless data services.

This annex defines the TAF integral to a Portable Part (PP) and the IWF integral to a Fixed Part (FP) which enable the attachment of synchronous serial data applications to a PP and the attachment of isochronous connection-oriented serial data transmission network services to an FP. The application may be a software application or a terminal: however this annex does not mandate the implementation of a specific interface between the PP and the terminal and the FP and the service/network, but specifies the air interface requirements in order to facilitate interoperability between equipment of different origin. Subclause B.1.5 of this annex specifies interworking conventions for Data Terminal Equipment (DTE)-to-PP interfaces based on CCITT Recommendation V.24 [11], and corresponding conventions for FP IWUs with a nominal internal V.24 interface.

#### B.1.2 Reference configuration

The reference configuration for U-plane and C-plane operation is shown in figures B.1 and B.2, respectively. The present document refers to Portable Parts (PPs) and Fixed Parts (FPs) which support applications with synchronous serial data transmission capabilities. The TAF is functionally a part of a PP and the IWF is functionally part of FP with an integral synchronous data capability of the DECT D.2 profile.

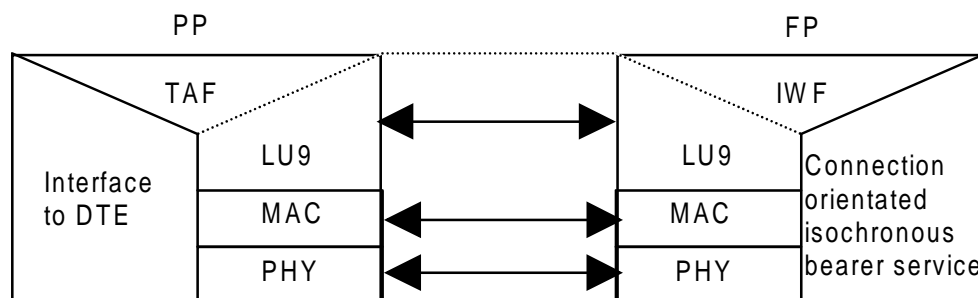

**Figure B.1: Profile reference U-plane configuration showing the interworking to a connection-oriented isochronous bearer service**

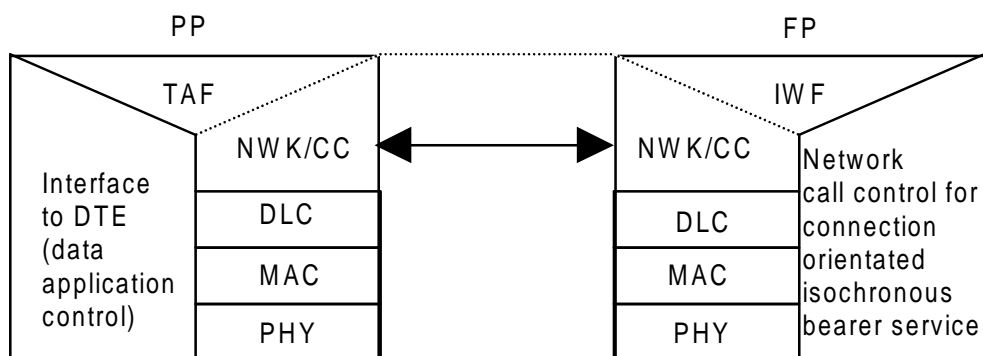

**Figure B.2: Profile reference C- plane configuration showing the interworking to the connection-oriented isochronous bearer service**

The serial data application may implement any proprietary TAF-interface solution using the services provided by the TAF in order to facilitate application/terminal connection (such as V.24, V.35 or X.21). The serial data transmission service contains a network specific interworking unit using the IWF services to provide interconnection to outside networks such as PSTN, ISDN or Global System for Mobile communication (GSM). Subclause B.1.5 defines the TAF and the IWF for a V.24 modem service as an example.

### B.1.2.1 PP

The following functions are included in the PP:

C-plane:

- CC procedures including service negotiation;
- MM;

U - plane:

- DECT Independent Clocking (DIC);
- In-band rate changes;
- V.24 control information handling.

NOTE: The management of DIC, in-band rate changes and V.24 control information is described in annex A.

### B.1.2.2 FP

The following functions are included in the FP:

C-plane:

- CC procedures including service negotiation;
- MM;

U - plane:

- DECT Independent Clocking (DIC);
- In-band rate changes;
- V.24 control information handling.

NOTE: The management of DIC, in-band rate changes and V.24 control information is described in annex A.

### B.1.2.3 General configuration

For negotiation of the service parameters the <<IWU-ATTRIBUTES>> information element as defined in clause B.2 shall be used. The Profile subtype field in octet 4 shall indicate the "Unprotected Rate Adaptation" service. The IWU service field in octet 5 shall indicate the service required. If the service required is an ITU V series service, octets 6 to 6d shall define the related parameters. The Symmetry field in octet 6 shall define if the requested connection is a full duplex asymmetric connection or a full duplex symmetric one. Octets 7 to 7c shall define the minimum and maximum allowed data rates, in both directions. If the IWU is allowed to negotiate data-rates with the far end modem after the call has been established (through a fall-back mechanism) this shall be indicated in bit 5 of octet 6.

### B.1.3 PP C-plane procedures

The C-plane procedures are those of the GAP (ETS 300 444 [8]) with the additional CC elements (to cover data specific aspects of the call setup) specified in clause 8.

The service specific configuration information is carried in the <<IWU-ATTRIBUTES>> information element of the {CC-SETUP} message. The values in the information element will contain the service requirements set by the user. The called user number is conveyed in <<MULTI\_KEYPAD>> information element of the {CC-INFO} message.

In addition, where service parameter negotiation is provided, the TAF shall be responsible for negotiating the service parameters. Service parameter negotiation is only supported during the call establishment phase. This is implemented by reflecting a modified set of service parameters to the call initiator in the {CC-RELEASE-COM} message. The initiator of the {CC-SETUP} message may then establish a new call using the modified parameters in a new {CC-SETUP} message. The procedure is detailed in ETS 300 175-5 [5], subclause 15.2.3.

### B.1.4 FP C-plane procedures

The C-plane procedures are those of the GAP (ETS 300 444 [8]) with the additional CC information elements (to cover data specific aspects of the call setup) specified in clause 8.

The service specific configuration information is carried in the <<IWU-ATTRIBUTES>> information element of the {CC-SETUP} message. The values in the information element will contain the service requirements set by the user. The called user number is conveyed in <<MULTI\_KEYPAD>> information element of {CC-INFO} message.

Specific functionality is required of the IWF depending on the service which is being requested to be supported. The selection of the appropriate Interworking Unit (IWU) will be determined by the FP/IWF on the basis of information contained in the <<IWU-ATTRIBUTES>> information element signalled in the {CC-SETUP} request message.

In addition where service parameter negotiation is provided, the IWU shall be responsible for interworking the negotiation between the PP and the FP and between the FP and the attached network. Service parameter negotiation is only supported during the call establishment phase. This is implemented by reflecting a modified set of service parameters to the call initiator in the {CC-RELEASE-COM} message. The initiator of the {CC-SETUP} message may then establish a new call using the modified parameters in a new {CC-SETUP} message. In the case of an outgoing call the FP shall also release the associated call into the network if this is already established. In the case of incoming call the IWF shall upon receipt of an {RELEASE-COM} message either:

- attempt another {CC-SETUP} for the same incoming call provided the RELEASE-COM message contained an acceptable set of modified service parameters; or
- notify the network of the {CC-SETUP} failure giving the release reason specified in the {RELEASE-COM} message.

## B.1.5 Network modem interworking service using V.24 connection

### B.1.5.1 General

This subclause specifies the interworking of the DECT D.2 services with DTE connected by V.24 to the PP. It also specifies the functionality of the corresponding IWU in the FP by means of a nominal, reference V.24 interface to ITU-T-specified DCE. This subclause will describe how ITU-T Recommendation V.24 [11] signalling should take place in the TAF and in the IWU.

This subclause (and related subclauses) do not specify or require the physical realization of V.24 capable interfaces for equipment claiming support of this interworking annex. Instead they require only the logical realization of equivalent functionality with the aim of DECT air interface interoperability.

### B.1.5.2 Reference configuration

The reference configuration is illustrated in figure B.3.

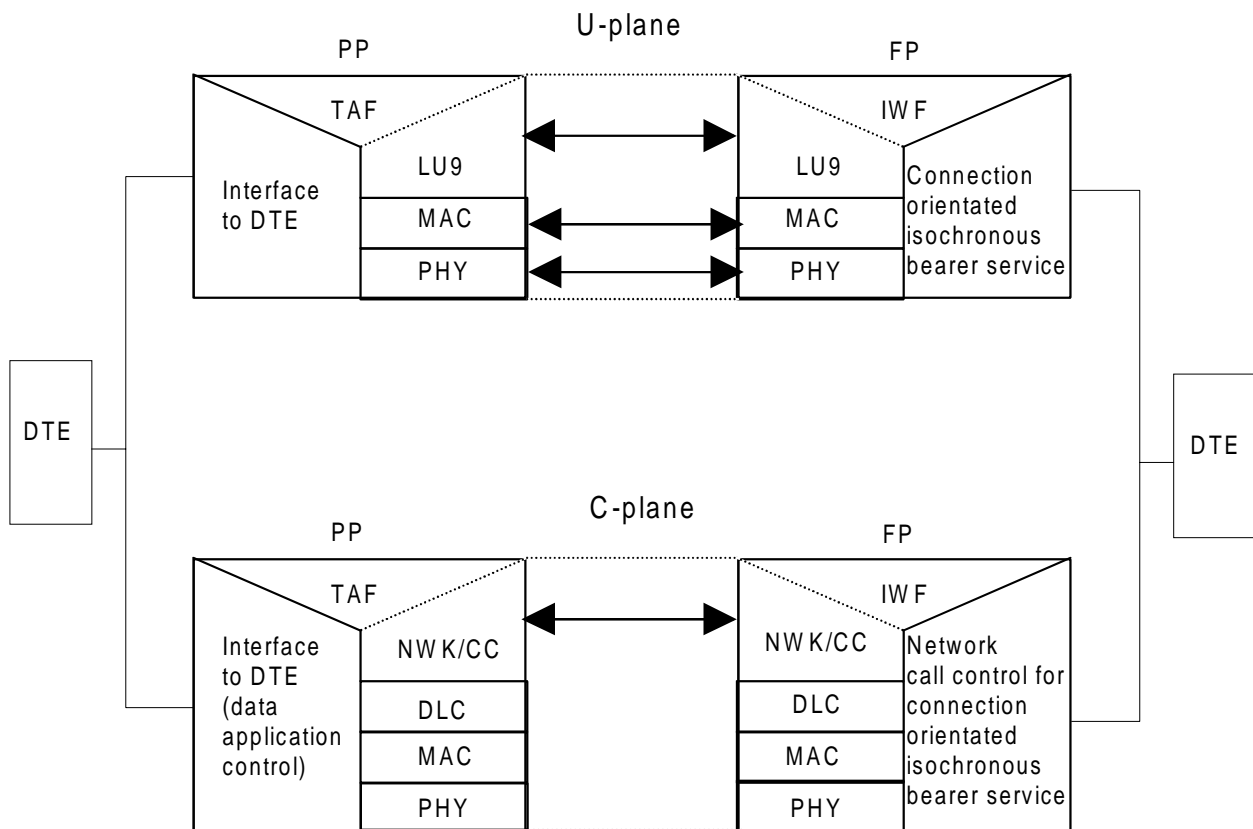

**Figure B.3: The reference configuration**

### B.1.5.3 TAF interworking to V.24

#### B.1.5.3.1 General

The V.24 TAF emulates DCE towards the DTE while interworking the V.24 status to the CC and DLC primitives. The implementation of the V.24 interface is not mandatory in the context of this interworking annex, but if the V.24 interface is implemented physically or logically in the TAF then the provisions of this subclause are mandatory. The rules are applicable for both manual and automatic calling.

#### B.1.5.3.2 V.24 Interchange circuit handling rules

The circuit 108/2 (DTR) is required to be in the ON state before the PT/TAF may initiate call establishment (manual or automatic). The circuit 108/2 (DTR) may be used to indicate with ON state to the PT/TAF that the DTE is ready to accept an incoming call.

In the active state, the 108/2 (DTR) transition from ON to OFF state shall cause the TAF to release the connection, after an implementation-specific timeout by issuing an MNCC-RELEASE-req primitive with Release Reason "User Detached".

If 108/2(DTR) is OFF, the TAF shall respond to an incoming call with a MNCC-ALERT-req primitive and shall turn ON circuit 125 (RI). If circuit 108/2(DTR) goes ON in this condition, the TAF shall issue an MNCC-CONNECT-req primitive. It shall be an implementation-specific feature for the TAF to time-out if circuit 108/2 (DTR) does not go ON in this condition, in which case it shall issue an MNCC-RELEASE-req primitive. The TAF may also issue an MNCC-RELEASE-req. primitive independently of the state of circuit 108/2 (DTR), for implementation-specific reasons.

The status change of circuit 107 (DSR) from OFF to ON by PT/TAF shall indicate to the DTE that network call establishment has been successful, that a far-end modem has been detected and that negotiation to establish a carrier has begun.

The status change of 107 (DSR) from ON to OFF by PT/TAF shall indicate to the DTE that the call has been released. Circuit 107 (DSR) shall be turned OFF when the PT/TAF receives MNCC-REJECT-ind primitive.

Circuit 109 (DCD) and 106 (CTS) may be turned ON by the PT/TAF, when a DLU-LU9\_CTRL.ind primitive is received reporting these circuits ON during the call establishment, indicating to the DTE the successful establishment of a data carrier to the far-end modem, and the availability of service for end-to-end data transfer. PT/TAF shall transfer the status of circuit 106 (CTS) during the call, as indicated by the DLU-LU9\_CTRL.ind primitive, managing momentary unavailability of the fixed network connection due to modem retrains and/or rate renegotiation. PT/TAF shall turn OFF circuit 109 (DCD) if the value of this circuit, as transferred by a DLU-LU9\_CTRL.ind primitive, is set to OFF, or if the call is released. PT/TAF shall be responsible for turning circuit 109 (DCD) OFF before circuit 107 (DSR) is turned OFF if it is not already OFF. The status of circuits 105 (RTS) shall not be conveyed across the radio interface.

#### B.1.5.3.3 Call establishment signalling handling

The TAF shall control call establishment by means of the relevant MNCC primitives, in accordance with the procedures of the GAP. Information about the state of call establishment may be transferred by the TAF to the DTE using V.24 control signals or locally defined means. Such information is expected to include notification of the MNCC-CALL\_PROC-ind, MNCC-ALERT-ind and MNCC-CONNECT-ind primitives. In particular, the TAF shall include means to provide notification to the DTE or the user of the MNCC-CONNECT-ind primitive.

#### B.1.5.3.4 Data transmission

The data is interworked for LU9 in the PP as described in annex A. For the purposes of this interworking annex the connection over the LU9 service is always a duplex service.

Where octet integrity is available (e.g. 8 bit data async) to and from the PP application the TAF shall maintain this integrity with respect to the receiving and transmitting of user data via LU9.

## B.1.5.4 DECT FP Interworking procedures

### B.1.5.4.1 General

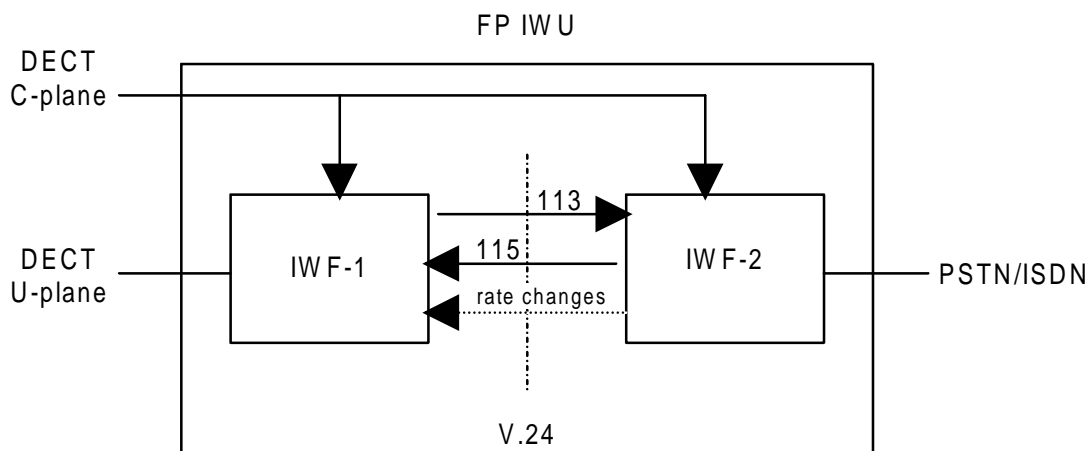

**Figure B.4: FP IWU reference configuration**

This subclause specifies the interworking procedures for the IWU of the PSTN/ISDN modem service. This IWU is split into 2 sub-functions called IWF-1 and IWF-2 as shown in figure B.4. IWF-2 is the only function which is attached to the local fixed network. From the perspective of the network this shall function exactly like an ITU V. series voice-band modem or an ITU-T Recommendation V.110 [20] ISDN termination.

Establishment and release of the PSTN/ISDN calls by IWF-2 shall be controlled on the DECT side by the GAP procedures. The CC primitive parameters have been extended to support the non-voice services standardized herein.

The FP IWU reference configuration defines a logical V.24 reference point between IWF-1 and IWF-2. This is used to simplify the specification of the interworking of the U-plane data to the modem data since the ITU V. series modems (including ITU-T Recommendation V.110 [20]) are specified with respect to the V.24 interface. This shall not in any way restrict the implementation of the FP IWU. In addition, the V.24 logical interface shall support primitives for transferring in-band rate changes from IWF-2 to IWF-1, due to modem rate-renegotiation procedures.

IWF-1 shall provide the PP TAF transmission clock to IWF-2, as regenerated by means of the DIC functionality, if provided. IWF-1 shall transfer to the PP TAF the clock signal coming from IWF-2 by means of the same functionality.

### B.1.5.4.2 Call establishment signalling handling

The modem call establishment is directly signalled to IWF-2 via the DECT network layer primitives and procedures standardized herein using the GAP interworking procedures.

If the selected service is an ITU-T V series voice-band modem the signalling to the local fixed network shall be identical to a standard 3,1 kHz audio call establishment up to the point where the FP CC enters the active state. At this point the behaviour of IWF-2 towards the network shall be in accordance with the ITU-T V series modem selected: the modem configuration parameters (e.g. the type of connection (symmetric or asymmetric), the data rates allowed and the ability of supporting the fall-back mechanism) shall be the ones in the <<IWU-ATTRIBUTES>> IE.

If the selected modem service is an ITU-T Recommendation V.110 [20] ISDN modem the signalling to the local fixed network shall follow the standard ISDN call setup procedures for the ITU-T Recommendation V.110 [20] service. The ITU-T Recommendation V.110 [20] call setup parameters for the ISDN call shall use the appropriate parameters from octets 6 to 7c of the <<IWU-ATTRIBUTES>> IE and shall allocate the remaining ITU-T Recommendation V.110 [20] parameters according to the capabilities of IWF-2.



The 'Answer' indication from the local fixed network shall be understood when one or more of the following has been detected:

- 1) off-hook for the called party has been detected;
- 2) charging for this call has started;
- 3) a CONNECT message has been received (e.g. from an ISDN network);
- 4) the 2 100 Hz modem tone has been detected.

Depending on the attached local fixed network and the called party it may not be possible to detect any of the above. Under such circumstances the FP IWU is permitted to issue a MNCC-RELEASE-req primitive following a timeout period indicating release reason 'timer expired'.

#### B.1.5.4.3 V.24 Interchange circuit handling rules

Circuit 107 (DSR) is required to be in the ON state before the IWF-1 may transmit data on circuit 103 (TXD).

The state of circuit 125 (RI) shall be ignored by IWF-1, since the presence of an incoming call shall be interworked to the DECT network by the IWF-2. The IWF-1 shall transfer the value of circuits 109 (DCD) and circuit 106 (CTS) in DLU9\_CONTROL.req primitives using the codings defined in annex A.

Data received via DLU\_DATA-req primitives shall be interworked to circuit 103 (TXD). Data received on circuit 104 (RXD) shall be interworked to DL\_U\_DATA-ind.

#### B.1.5.4.4 Modem selection

For an outgoing call, the modem type in IWF-2 is selected according to the "modem type" coding of the <<IWU-ATTRIBUTES>> parameter. If this value is not supported by IWF-2, the supported service negotiation procedures shall be invoked by the IWU. If no acceptable modem can be negotiated, the call is rejected with an MNCC-RELEASE-COM-req primitive with release reason (hex) 05 "Incompatible service".

For an incoming call, a locally determined value of the modem type shall be used by the IWU in the MNCC-SETUP-req primitive. The corresponding IWU service and setting parameters shall be indicated in the transmitted <<IWU-ATTRIBUTES>> IE. A PP-initiated peer attribute negotiation (ETS 300 175-5 [5], subclause 15.2.5) may be used to modify this value, otherwise the IWF-2 may locally determine a new value after it has received the MNCC-CONNECT-ind primitive and has consequently responded to the incoming call and has agreed the modem type to be used. It shall then communicate this in an MNCC-CONNECT\_ACK-req primitive.

#### B.1.5.4.5 Data transmission

The data is interworked for LU9 in the FP as described in annex A. For the purposes of this interworking annex the connection over the LU9 service is always a duplex service.

Where octet integrity is available (e.g. 8 bit data async) to and from the DECT local network the IWF shall maintain this integrity with respect to the receiving and transmitting of user data via LU9.

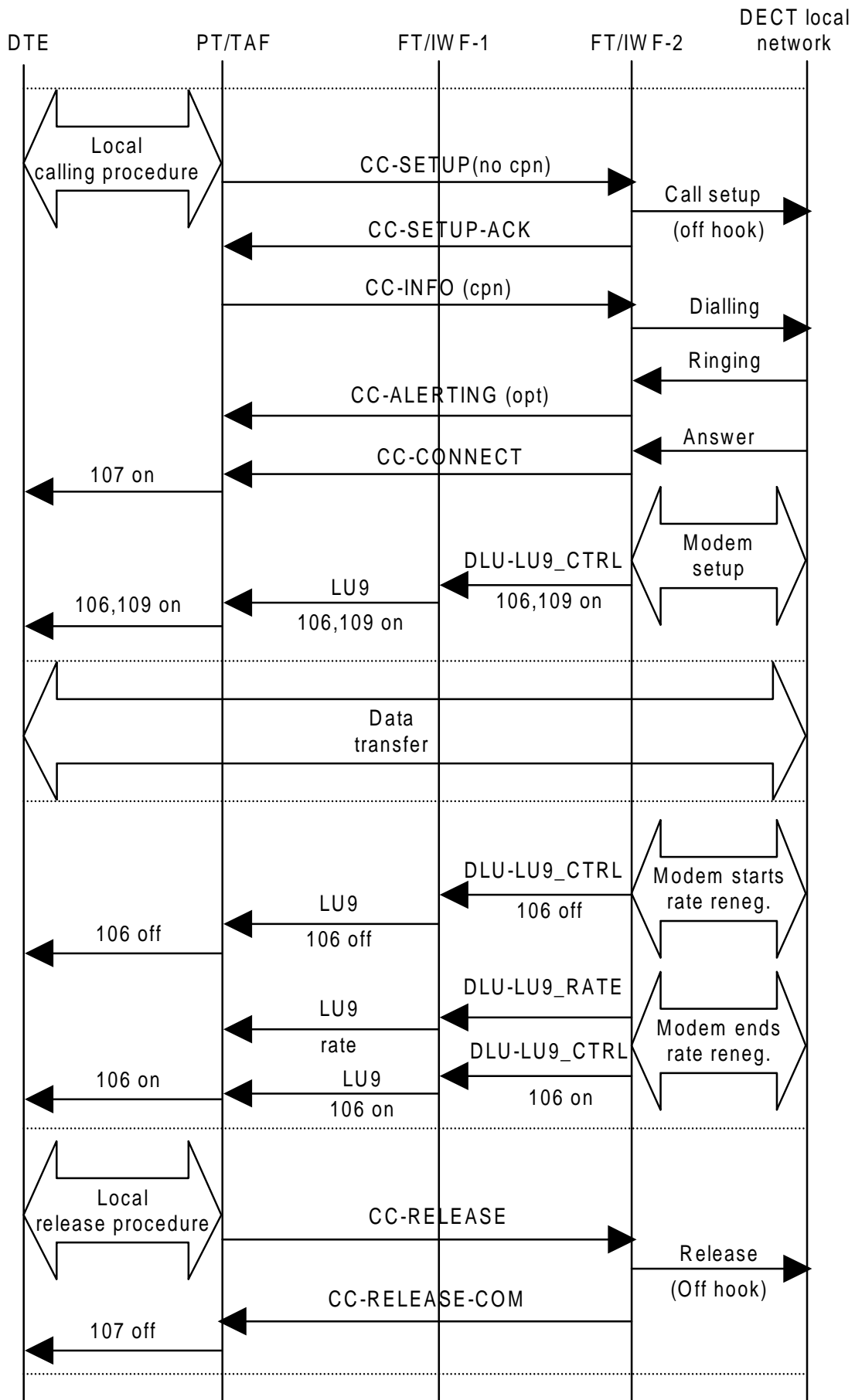

Figure B.5: PP originated call

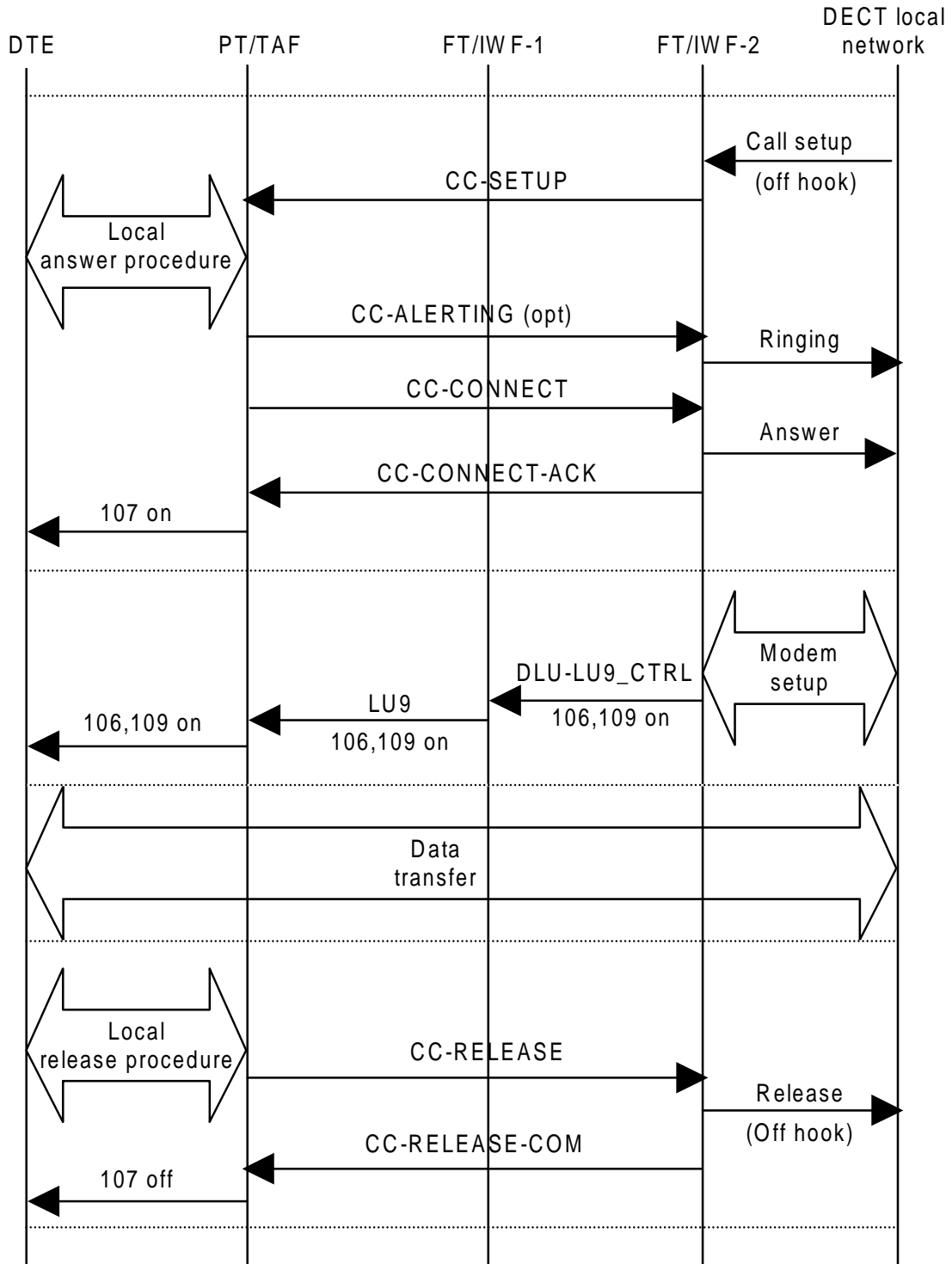

Figure B.6: PP terminated call

## B.2 <<IWU-ATTRIBUTES>> coding

Bit:	8	7	6	5	4	3	2	1	Octet
0	<<IWU-ATTRIBUTES>>								1
	Length of contents (L)								2
1	Coding standard			Profile					3
1	Negotiation Indicator			Profile subtype					4
0/1	IWU service								5
1	Symmetry		Fbk	Rate Res.		Spare			6
0/1	Min user data rate Tx								7
0/1	Max user data rate Tx								7a
0/1	Min user data rate Rx								7b
1	Max user data rate Rx								7c

### IWU-ATTRIBUTES information element

#### Coding standard (octet 3):

Bits	7 6	Meaning
	0 1	Profile defined coding

#### Profile (octet 3):

Bits	5 4 3 2 1	Meaning
	0 0 0 1 0	D data profile

#### Negotiation indicator (octet 4):

Bits	7 6 5	Meaning
		These bits are defined as specified ETS 300 175-5 [5], subclause 7.7.21 Interworking Unit Attributes when the coding standard (octet 3) indicates "Profile defined coding".

#### Profile subtype (octet 4):

Bits	4 3 2 1	Meaning
	0 0 0 0	32 kbit/s unprotected
	0 0 0 1	unprotected rate adaptation
		All other values reserved.

**IWU service (octet 5):**

<b>Bits</b>	<b>7 6 5 4 3 2 1</b>	<b>Meaning</b>
	0 0 0 0 0 0 0	Unspecified V.series voice-band modem
	0 0 0 0 0 0 1	V.21
	0 0 0 0 0 1 0	V.22
	0 0 0 0 0 1 1	V.22 bis
	0 0 0 0 1 0 0	V.23
	0 0 0 0 1 0 1	V.26 bis
	0 0 0 0 1 1 0	V.26 ter
	0 0 0 0 1 1 1	V.27
	0 0 0 1 0 0 0	V.27 ter
	0 0 0 1 0 0 1	V.32
	0 0 0 1 0 1 0	V.32
	0 0 0 1 0 1 1	V.34
	0 0 0 1 1 0 0	V.110
	0 0 0 1 1 0 1	V.120
	0 0 0 1 1 1 0	V.24
	0 0 0 1 1 1 1	32 kbit/s unprotected
	0 0 1 1 0 0 0	H.324 via 32 kbit/s (DECT annex)
	0 0 1 1 0 0 1	ATM AAL-1
	1 1 1 1 1 1 1	Escape
		All other values reserved.

**Symmetry (octet 6):**

<b>Bits</b>	<b>7 6</b>	<b>Meaning</b>
	0 0	Asymmetric, full duplex
	0 1	Symmetric, full duplex
		All other values reserved.

**Fbk (octet 6):**

<b>Bits</b>	<b>5</b>	<b>Meaning</b>
	0	Bit rate fall back supported
	1	Bit rate fall back not supported

**Rate Resolution (octet 6):**

<b>Bits</b>	<b>4 3</b>	<b>Meaning</b>
	0 0	$n \times 2,4$ kbit/s
	0 1	$n \times 4$ kbit/s
		All other values reserved.

**Min user data rate Tx (octet 7):**

If the **user data rate resolution** in octet 6 (bits 3-4) indicate ' $n \times 2,4$  kbit/s' then:

Bits	7 6 5 4 3 2 1	Meaning
	0 0 0 0 0 0 0	0 kbit/s
	0 0 0 0 0 0 1	2,4 kbit/s
	0 0 0 0 0 1 0	4,8 kbit/s
	0 0 0 0 0 1 1	7,2 kbit/s
	0 0 0 0 1 0 0	9,6 kbit/s
	0 0 0 0 1 0 1	12 kbit/s
	0 0 0 0 1 1 0	14,4 kbit/s
	0 0 0 0 1 1 1	16,8 kbit/s
	0 0 0 1 0 0 0	19,2 kbit/s
	0 0 0 1 0 0 1	21,6 kbit/s
	0 0 0 1 0 1 0	24 kbit/s
	0 0 0 1 0 1 1	26,4 kbit/s
	0 0 0 1 1 0 0	28,8 kbit/s
		All other values reserved.

If the **user data rate resolution** in octet 6 (bits 3-4) indicate ' $n \times 4$  kbit/s' then:

Bits	7 6 5 4 3 2 1	Meaning
	0 0 0 0 0 0 0	0 kbit/s
	0 0 0 0 0 0 1	4 kbit/s
	0 0 0 0 0 1 0	8 kbit/s
	0 0 0 0 0 1 1	12 kbit/s
	0 0 0 0 1 0 0	16 kbit/s
	0 0 0 0 1 0 1	20 kbit/s
	0 0 0 0 1 1 0	24 kbit/s
	0 0 0 0 1 1 1	28 kbit/s
		All other values reserved.

**Max user data rate Tx (octet 7a) (optional):**

This octet is optional. If omitted, the max user data rate Tx shall be interpreted as equal to the rate indicated by octet 7 and octets 7b and 7c shall not be included.

Bits	7 6 5 4 3 2 1	Meaning
		The coding of these bits is identical to the coding of bits 1-7 of octet 7.

**Min user data rate Rx (octet 7b) (optional):**

This octet is optional. If omitted, the min user data rate Rx shall be interpreted as equal to the rate indicated by octet 7 and octet 7c shall not be included.

Bits	7 6 5 4 3 2 1	Meaning
		The coding of these bits is identical to the coding of bits 1-7 of octet 7.

**Max user data rate Rx (octet 7c) (optional):**

This octet is optional. If omitted the max user data rate Rx shall be interpreted as equal to the rate indicated by octet 7b.

Bits	7 6 5 4 3 2 1	Meaning
		The coding of these bits is identical to the coding of bits 1-7 of octet 7.

---

## Annex C (normative): Service D2; PT Profile Implementation Conformance Statement (ICS) - PHL layer

For all the services, the requirements indicated in ETS 300 474-1 [13], clause A.5 shall apply.

---

## Annex D (normative): Service D2; FT Profile Implementation Conformance Statement (ICS) - PHL layer

For all the services, the requirements indicated in ETS 300 474-2 [14], clause A.5 shall apply.



## Annex E (normative): Service D2; PT Profile Implementation Conformance Statement (ICS) and PT Protocol Implementation Conformance Statement (PICS) proforma - Medium Access Control (MAC) layer

### Profile status column

The standardized symbols for the status column are as follows:

m or M	mandatory - the capability is required to be supported.
o or O	optional - the capability may be supported or not.
n/a or N/A	not applicable - in the given context, it is impossible to use the capability.
x or X	prohibited (excluded) - there is a requirement not to use this capability in the given context.
o.i or O.i	qualified optional - for mutually exclusive or selectable options from a set. "i" is an integer which identifies an unique group of related optional items and the logic of their selection which is defined immediately following the table.
ci or Ci	conditional - the requirement on the capability ("m", "o", "x" or "n/a") depends on the support of other optional or conditional items. "i" is an integer identifying an unique conditional status expression which is defined immediately following the table or which is defined in the general condition table below.
i or I	out-of-scope - this capability is outside the scope of the given specification, and hence irrelevant and not subject to conformance testing. This status is in particular applicable for data fields which are reserved for future use. The structure of such fields has to be supported, but the value is undefined and thus to be ignored.

If appropriate, a "C" followed by an integer is placed in the status column, providing a reference to a conditional status expression defined elsewhere in the PICS proforma. The following conditions are applicable throughout the entire document:

Condition identifier	Condition definition
C1	IF "32 kbit/s unprotected service" supported THEN m ELSE i
C2	IF "unprotected rate adaptation service" supported THEN m ELSE i

## E.1 Service D2; PT Profile Implementation Conformance Statement (ICS) - Medium Access Control (MAC) layer

The requirements indicated in ETS 300 474-1 [13], clause A.4 and the requirements indicated in ETS 300 476-3 [16] shall apply, except for the modifications and/or additions listed below:

**Table E.1: ETS 300 474-1 [13], Table A.103**

Item	Connection oriented control services	Profile reference	Profile status
1	Basic connections	ETS 300 444 [8], subclause 5.2	C1
2	Advanced symmetric connections	ETS 300 175-3 [3], subclause 5.6.2.1	C2

**Table E.2: ETS 300 474-1 [13], Table A.104**

Item	Connection services	Profile reference	Profile status
1	Connection setup (Basic connections)	ETS 300 444 [8], subclause 5.2	C1
3	Connection data transfer (Basic connections)	ETS 300 444 [8], subclause 5.2	C1
4	Connection handover (intra-cell, inter-cell)	ETS 300 444 [8], subclause 5.2	C1
5	Connection release (Basic connections)	ETS 300 444 [8], subclause 5.2	C1

**Table E.3: ETS 300 474-1 [13], Table A.105**

Item	Symmetric connection oriented services	Profile reference	Profile status
1	Type 1 IN_minimum_delay (General)	ETS 300 444 [8], subclause 5.2, 10.1	C1
2	Type 2 IN_normal_delay	ETS 300 175-3 [3], subclause 5.6.2.1	C2

**Table E.4: ETS 300 474-1 [13], Table A.115**

Item	Name of procedure	Profile reference	Profile status
1	Basic setup, single bearer basic connection of known service (Setup of basic connection, basic bearer setup (A-field))	ETS 300 444 [8], subclause 10.4	C1
2	Normal setup, single bearer duplex connection known service	ETS 300 175-3 [3], subclause 10.2.4.2	C2

**Table E.5: ETS 300 474-1 [13], Table A.116**

Item	Name of procedure	Profile reference	Profile status
1	Basic bearer setup	ETS 300 444 [8], subclause 10.4	C1

**Table E.6: ETS 300 474-1 [13], Table A.129: MAC control (M<sub>T</sub>) messages  
(Sending P to F)**

Item	MAC control (M <sub>T</sub> ) messages	Profile reference	Profile status
1	Basic connection control	ETS 300 444 [8], subclause 10.4	C1
3	Advanced connection control	ETS 300 175-3 [3], subclause 7.2.5.1	C2

**Table E.7: ETS 300 474-1 [13], Table A.130: MAC control (M<sub>T</sub>) messages  
(Receipt F to P)**

Item	MAC control (M <sub>T</sub> ) messages	Reference	Status
1	Basic connection control	ETS 300 444 [8], subclause 10.4	C1
3	Advanced connection control	ETS 300 175-3 [3], subclause 7.2.5.1	C2

## E.2 Service D2; PT Protocol Implementation Conformance Statement (PICS) proforma - Medium Access Control (MAC) layer

Notwithstanding the provisions of the copyright clause related to the text of the present document, ETSI grants that users of the present document may freely reproduce the PICS proforma in this clause so that it can be used for its intended purposes and may further publish the completed PICS.

The requirements indicated in ETS 300 476-3 [16] shall apply, except for the modifications and/or additions listed below:

**Table E.8: ETS 300 476-3 [16], Table A.11: Connection services**

Item	Connection services	Reference	Status	Support
1	Connection setup (Advanced connections)	ETS 300 444 [8], subclause 10.2	C2	
2	Connection modification (Advanced connections)	ETS 300 444 [8], subclause 10.3	C2	
3	Connection data transfer (Advanced connections)	ETS 300 444 [8], subclause 10.8	C2	
4	Connection release (Advanced connections)	ETS 300 444 [8], subclause 10.4	C2	

**Table E.9: ETS 300 476-3 [16], Table A.57: System Information (Q<sub>T</sub>) message  
(Receipt F to P)**

Item	System Information message	Reference	Status	Support
4	Q <sub>T</sub> - Extended Fixed Part Capabilities	ETS 300 175-3 [3], subclause 7.2.3.5	m	

**Table E.10: ETS 300 476-3 [16], Table A.66: Advanced connection control messages  
(Sending P to F)**

Item	MAC control (M <sub>T</sub> ) messages - Advanced connection control	Reference	Status	Support
1	Advanced CC - access request	ETS 300 175-3 [3], subclause 7.2.5.3.2	C2	
2	Advanced CC - bearer handover request	ETS 300 175-3 [3], subclause 7.2.5.3.3	C2	
3	Advanced CC - connection handover request	ETS 300 175-3 [3], subclause 7.2.5.3.4	C2	
5	Advanced CC - bearer confirm	ETS 300 175-3 [3], subclause 7.2.5.3.6	C2	
6	Advanced CC - wait	ETS 300 175-3 [3], subclause 7.2.5.3.7	C2	
7	Advanced CC - attributes_T.request	ETS 300 175-3 [3], subclause 7.2.5.3.8	C2	
8	Advanced CC - attributes_T.confirm	ETS 300 175-3 [3], subclause 7.2.5.3.8	C2	
14	Advanced CC - release	ETS 300 175-3 [3], subclause 7.2.5.3.13	C2	

**Table E.11: ETS 300 476-3 [16], Table A.67: Advanced connection control messages  
(Receipt F to P)**

Item	MAC control (M <sub>T</sub> ) messages - Advanced connection control	Reference	Status	Support
1	Advanced CC - access request	ETS 300 175-3 [3], subclause 7.2.5.3.2	C2	
2	Advanced CC - bearer handover request	ETS 300 175-3 [3], subclause 7.2.5.3.3	x	
3	Advanced CC - connection handover request	ETS 300 175-3 [3], subclause 7.2.5.3.4	C2	
5	Advanced CC - bearer confirm	ETS 300 175-3 [3], subclause 7.2.5.3.6	C2	
6	Advanced CC - wait	ETS 300 175-3 [3], subclause 7.2.5.3.7	C2	
7	Advanced CC - attributes_T.request	ETS 300 175-3 [3], subclause 7.2.5.3.8	C2	
8	Advanced CC - attributes_T.confirm	ETS 300 175-3 [3], subclause 7.2.5.3.8	C2	
14	Advanced CC - release	ETS 300 175-3 [3], subclause 7.2.5.3.13	C2	

**Table E.12: ETS 300 476-3 [16], Table A.130: Advanced CC - access request  
(Sending P to F)**

Item	Advanced CC - access request	Reference	Status	Support	Value allowed	Value supported
1	M <sub>T</sub> header	ETS 300 175-3 [3], subclause 7.2.5.3.2	C2		"0001"B	
2	Command	ETS 300 175-3 [3], subclause 7.2.5.3.2	C2		"0000"B	
3	FMID	ETS 300 175-3 [3], subclause 7.2.5.3.2	C2		12 bits value	
4	PMID	ETS 300 175-3 [3], subclause 7.2.5.3.2	C2		20 bits value	

**Table E.13: ETS 300 476-3 [16], Table A. 131: Advanced CC - access request  
(Receipt F to P)**

Item	Advanced CC - access request	Reference	Status	Support	Value allowed	Value supported
1	M <sub>T</sub> header	ETS 300 175-3 [3], subclause 7.2.5.3.2	C2		"0001"B	
2	Command	ETS 300 175-3 [3], subclause 7.2.5.3.2	C2		"0000"B	
3	FMID	ETS 300 175-3 [3], subclause 7.2.5.3.2	C2		12 bits value	
4	PMID	ETS 300 175-3 [3], subclause 7.2.5.3.2	C2		20 bits value	

**Table E.14: ETS 300 476-3 [16], Table A.132: Advanced CC - bearer handover request  
(Sending P to F)**

Item	Advanced CC - bearer handover request	Reference	Status	Support	Value allowed	Value supported
1	M <sub>T</sub> header	ETS 300 175-3 [3], subclause 7.2.5.3.3	C2		"0001"B	
2	Command	ETS 300 175-3 [3], subclause 7.2.5.3.3	C2		"0001"B	
3	FMID	ETS 300 175-3 [3], subclause 7.2.5.3.3	C2		12 bits value	
4	PMID	ETS 300 175-3 [3], subclause 7.2.5.3.3	C2		20 bits value	

**Table E.15: ETS 300 476-3 [16], Table A.133: Advanced CC - connection handover request  
(Sending P to F)**

Item	Advanced CC - connection handover request	Reference	Status	Support	Value allowed	Value supported
1	M <sub>T</sub> header	ETS 300 175-3 [3], subclause 7.2.5.3.4	C2		"0001"B	
2	Command	ETS 300 175-3 [3], subclause 7.2.5.3.4	C2		"0010"B	
3	FMID	ETS 300 175-3 [3], subclause 7.2.5.3.4	C2		12 bits value	
4	PMID	ETS 300 175-3 [3], subclause 7.2.5.3.4	C2		20 bits value	

**Table E.16: ETS 300 476-3 [16], Table A.134: Advanced CC - connection handover request  
(Receipt F to P)**

Item	Advanced CC - connection handover request	Reference	Status	Support	Value allowed	Value supported
1	M <sub>T</sub> header	ETS 300 175-3 [3], subclause 7.2.5.3.4	C2		"0001"B	
2	Command	ETS 300 175-3 [3], subclause 7.2.5.3.4	C2		"0010"B	
3	FMID	ETS 300 175-3 [3], subclause 7.2.5.3.4	C2		12 bits value	
4	PMID	ETS 300 175-3 [3], subclause 7.2.5.3.4	C2		20 bits value	

**Table E.17: ETS 300 476-3 [16], Table A.137: Advanced CC - bearer confirm  
(Sending P to F)**

Item	Advanced CC - bearer confirm	Reference	Status	Support	Value allowed	Value supported
1	M <sub>T</sub> header	ETS 300 175-3 [3], subclause 7.2.5.3.6	C2		"0001"B	
2	Command	ETS 300 175-3 [3], subclause 7.2.5.3.6	C2		"0100"B	
3	FMID	ETS 300 175-3 [3], subclause 7.2.5.3.6	C2		12 bits value	
4	PMID	ETS 300 175-3 [3], subclause 7.2.5.3.6	C2		20 bits value	

**Table E.18: ETS 300 476-3 [16], Table A.138: Advanced CC - bearer confirm  
(Receipt F to P)**

Item	Advanced CC - bearer confirm	Reference	Status	Support	Value allowed	Value supported
1	M <sub>T</sub> header	ETS 300 175-3 [3], subclause 7.2.5.3.6	C2		"0001"B	
2	Command	ETS 300 175-3 [3], subclause 7.2.5.3.6	C2		"0100"B	
3	FMID	ETS 300 175-3 [3], subclause 7.2.5.3.6	C2		12 bits value	
4	PMID	ETS 300 175-3 [3], subclause 7.2.5.3.6	C2		20 bits value	

**Table E.19: ETS 300 476-3 [16], Table A.139: Advanced CC - wait  
(Sending P to F)**

Item	Advanced CC - wait	Reference	Status	Support	Value allowed	Value supported
1	M <sub>T</sub> header	ETS 300 175-3 [3], subclause 7.2.5.3.7	C2		"0001"B	
2	Command	ETS 300 175-3 [3], subclause 7.2.5.3.7	C2		"1111"B	
3	FMID	ETS 300 175-3 [3], subclause 7.2.5.3.7	C2		12 bits value	
4	PMID	ETS 300 175-3 [3], subclause 7.2.5.3.7	C2		20 bits value, "11110000 11110000 1111"B	

**Table E.20: ETS 300 476-3 [16], Table A.140: Advanced CC - wait  
(Receipt F to P)**

Item	Advanced CC - wait	Reference	Status	Support	Value allowed	Value supported
1	M <sub>T</sub> header	ETS 300 175-3 [3], subclause 7.2.5.3.7	C2		"0001"B	
2	Command	ETS 300 175-3 [3], subclause 7.2.5.3.7	C2		"1111"B	
3	FMID	ETS 300 175-3 [3], subclause 7.2.5.3.7	C2		12 bits value	
4	PMID	ETS 300 175-3 [3], subclause 7.2.5.3.7	C2		20 bits value, "11110000 11110000 1111"B	

**Table E.21: ETS 300 476-3 [16], Table A.141: Advanced CC - Attributes\_T request  
(Sending P to F)**

Item	Advanced CC - Attributes_T request	Reference	Status	Support	Value allowed	Value supported
1	M <sub>T</sub> header	ETS 300 175-3 [3], subclause 7.2.5.3.8	C2		"0001"B	
2	Command	ETS 300 175-3 [3], subclause 7.2.5.3.8	C2		"0110"B	
3	ECN	ETS 300 175-3 [3], subclause 7.2.5.3.8	C2		4 bits value	
4	LBN	ETS 300 175-3 [3], subclause 7.2.5.3.8	C2		"1111"	
5	Connection type	ETS 300 175-3 [3], subclause 7.2.5.3.8	C2		"11"B	
6	Service type	ETS 300 175-3 [3], subclause 7.2.5.3.8	C2		"001"B	
7	Maximum lifetime	ETS 300 175-3 [3], subclause 7.2.5.3.8	C2		"000"	
8	Slot type	ETS 300 175-3 [3], subclause 7.2.5.3.8	C2		"0000"B	
9	CF support flag	ETS 300 175-3 [3], subclause 7.2.5.3.8	C2		"0"B	
10	Spr	ETS 300 175-3 [3], subclause 7.2.5.3.8	C2		"111"B	
11	Spare	ETS 300 175-3 [3], subclause 7.2.5.3.8	C2		"0000 1111"B	

**Table E.22: ETS 300 476-3 [16], Table A.142: Advanced CC - Attributes\_T request  
(Receipt F to P)**

Item	Advanced CC - Attributes_T request	Reference	Status	Support	Value allowed	Value supported
1	M <sub>T</sub> header	ETS 300 175-3 [3], subclause 7.2.5.3.8	C2		"0001"B	
2	Command	ETS 300 175-3 [3], subclause 7.2.5.3.8	C2		"0110"B	
3	ECN	ETS 300 175-3 [3], subclause 7.2.5.3.8	C2		4 bits value	
4	LBN	ETS 300 175-3 [3], subclause 7.2.5.3.8	C2		"1111"	
5	Connection type	ETS 300 175-3 [3], subclause 7.2.5.3.8	C2		"11"B	
6	Service type	ETS 300 175-3 [3], subclause 7.2.5.3.8	C2		"001"B	
7	Maximum lifetime	ETS 300 175-3 [3], subclause 7.2.5.3.8	C2		"000"	
8	Slot type	ETS 300 175-3 [3], subclause 7.2.5.3.8	C2		"0000"B	
9	CF support flag	ETS 300 175-3 [3], subclause 7.2.5.3.8	C2		"0"B	
10	Spr	ETS 300 175-3 [3], subclause 7.2.5.3.8	C2		"111"B	
11	Spare	ETS 300 175-3 [3], subclause 7.2.5.3.8	C2		"0000 1111"B	

**Table E.23: ETS 300 476-3 [16], Table A.143: Advanced CC - Attributes\_T confirm  
(Sending P to F)**

Item	Advanced CC - Attributes_T confirm	Reference]	Status	Support	Value allowed	Value supported
1	M <sub>T</sub> header	ETS 300 175-3 [3], subclause 7.2.5.3.8	C2		"0001"B	
2	Command	ETS 300 175-3 [3], subclause 7.2.5.3.8	C2		"0111"B	
3	ECN	ETS 300 175-3 [3], subclause 7.2.5.3.8	C2		4 bits value	
4	LBN	ETS 300 175-3 [3], subclause 7.2.5.3.8	C2		"1111"	
5	Connection type	ETS 300 175-3 [3], subclause 7.2.5.3.8	C2		"11"B	
6	Service type	ETS 300 175-3 [3], subclause 7.2.5.3.8	C2		"001"B	
7	Maximum lifetime	ETS 300 175-3 [3], subclause 7.2.5.3.8	C2		"000"	
8	Slot type	ETS 300 175-3 [3], subclause 7.2.5.3.8	C2		"0000"B	
9	CF support flag	ETS 300 175-3 [3], subclause 7.2.5.3.8	C2		"0"B	
10	Spr	ETS 300 175-3 [3], subclause 7.2.5.3.8	C2		"111"B	
11	Spare	ETS 300 175-3 [3], subclause 7.2.5.3.8	C2		"0000 1111"B	

**Table E.24: ETS 300 476-3 [16], Table A.144: Advanced CC - Attributes\_T confirm  
(Receipt F to P)**

Item	Advanced CC - Attributes_T confirm	Reference	Status	Support	Value allowed	Value supported
1	M <sub>T</sub> header	ETS 300 175-3 [3], subclause 7.2.5.3.8	C2		"0001"B	
2	Command	ETS 300 175-3 [3], subclause 7.2.5.3.8	C2		"0111"B	
3	ECN	ETS 300 175-3 [3], subclause 7.2.5.3.8	C2		4 bits value	
4	LBN	ETS 300 175-3 [3], subclause 7.2.5.3.8	C2		"1111"	
5	Connection type	ETS 300 175-3 [3], subclause 7.2.5.3.8	C2		"11"B	
6	Service type	ETS 300 175-3 [3], subclause 7.2.5.3.8	C2		"001"B	
7	Maximum lifetime	ETS 300 175-3 [3], subclause 7.2.5.3.8	C2		"000"	
8	Slot type	ETS 300 175-3 [3], subclause 7.2.5.3.8	C2		"0000"B	
9	CF support flag	ETS 300 175-3 [3], subclause 7.2.5.3.8	C2		"0" B	
10	Spr	ETS 300 175-3 [3], subclause 7.2.5.3.8	C"m		"111"B	
11	Spare	ETS 300 175-3 [3], subclause 7.2.5.3.8	C"m		"0000 1111"B	



**Table E.25: ETS 300 476-3 [16], Table A.165: Advanced CC - release  
(Sending P to F)**

Item	Advanced CC - release	Reference	Status	Support	Value allowed	Value supported
1	M <sub>T</sub> header	ETS 300 175-3 [3], subclause 7.2.5.3.13	m		"0001"B	
2	Command	ETS 300 175-3 [3], subclause 7.2.5.3.13	m		"1111"B	
3	spr	ETS 300 175-3 [3], subclause 7.2.5.3.13	m		"0000"B	
4	LBN	ETS 300 175-3 [3], subclause 7.2.5.3.13	m		"1111"	
5	reason	ETS 300 175-3 [3], subclause 7.2.5.3.13	m		"0000"B .. "1101"B	
6	PMID	ETS 300 175-3 [3], subclause 7.2.5.3.13	m		20 bits value	

**Table E.26: ETS 300 476-3 [16], Table A.166: Advanced CC - release  
(Receipt F to P)**

Item	Advanced CC - release	Reference	Status	Support	Value allowed	Value supported
1	M <sub>T</sub> header	ETS 300 175-3 [3], subclause 7.2.5.3.13	m		"0001"B	
2	Command	ETS 300 175-3 [3], subclause 7.2.5.3.13	m		"1111"B	
3	spr	ETS 300 175-3 [3], subclause 7.2.5.3.13	m		"0000"B	
4	LBN	ETS 300 175-3 [3], subclause 7.2.5.3.13	m		"1111"	
5	reason	ETS 300 175-3 [3], subclause 7.2.5.3.13	m		"0000"B .. "1101"B	
6	PMID	ETS 300 175-3 [3], subclause 7.2.5.3.13	m		20 bits value	

## Annex F (normative): Service D2; FT Profile Implementation Conformance Statement (ICS) and Protocol Implementation Conformance Statement (PICS) proforma - Medium Access Control (MAC) layer

### Profile status column

The standardized symbols for the status column are as follows:

- m or M      mandatory - the capability is required to be supported.
- o or O      optional - the capability may be supported or not
- n/a or N/A    not applicable - in the given context, it is impossible to use the capability.
- x or X      prohibited (excluded) - there is a requirement not to use this capability in the given context.
- o.i or O.i    qualified optional - for mutually exclusive or selectable options from a set. "i" is an integer which identifies an unique group of related optional items and the logic of their selection which is defined immediately following the table.
- ci or Ci     conditional - the requirement on the capability ("m", "o", "x" or "n/a") depends on the support of other optional or conditional items. "i" is an integer identifying an unique conditional status expression which is defined immediately following the table or which is defined in the general condition table below.
- i or I      out-of-scope - this capability is outside the scope of the given specification, and hence irrelevant and not subject to conformance testing. This status is in particular applicable for data fields which are reserved for future use. The structure of such fields has to be supported, but the value is undefined and thus to be ignored.

If appropriate, a "C" followed by an integer is placed in the status column, providing a reference to a conditional status expression defined elsewhere in the PICS proforma. The following conditions are applicable throughout the entire document:

Condition identifier	Condition definition
C1	IF "32 kbit/s unprotected service" supported THEN m ELSE i
C2	IF "unprotected rate adaptation service" supported THEN m ELSE i

## F.1 Service D2; FT Profile Implementation Conformance Statement (ICS) - Medium Access Control (MAC) layer

The requirements indicated in ETS 300 474-2 [14], clause A.4 shall apply, except for the modifications and/or additions listed below:

**Table F.1: ETS 300 474-2 [14], Table A.103**

Item	Connection oriented control services	Reference	Status
1	Basic connections	ETS 300 444 [8], subclause 5.2	C1
2	Advanced symmetric connections	ETS 300 175-3 [3], subclause 5.6.2.1	C2

**Table F.2: ETS 300 474-2 [14], Table A.104**

Item	Connection services	Reference	Status
1	Connection setup (Basic connections)	ETS 300 444 [8], subclause 5.2	C1
3	Connection data transfer (Basic connections)	ETS 300 444 [8], subclause 5.2	C1
4	Connection handover (intra-cell, inter-cell)	ETS 300 444 [8], subclause 5.2	C1
5	Connection release (Basic connections)	ETS 300 444 [8], subclause 5.2	C1

**Table F.3: ETS 300 474-2 [14], Table A.105**

Item	Symmetric connection oriented services	Reference	Status
1	Type 1 IN_minimum_delay (General)	ETS 300 444 [8], subclauses 5.2, 10.1	C1
2	Type 2 IN_normal_delay	ETS 300 175-3 [3], subclause 5.6.2.1	C2

**Table F.4: ETS 300 474-2 [14], Table A.115**

Item	Name of procedure	Reference	Status
1	Basic setup, single bearer basic connection of known service (Setup of basic connection, basic bearer setup (A-field))	ETS 300 444 [8], subclause 10.4	C1
2	Normal setup, single bearer duplex connection known service	ETS 300 175-3 [3], subclause 10.2.4.2	C2

**Table F.5: ETS 300 474-2 [14], Table A.116**

Item	Name of procedure	Reference	Status
1	Basic bearer setup	ETS 300 444 [8], subclause 10.4	C1

**Table F.6: ETS 300 474-2 [14], Table A.128: MAC control (M<sub>T</sub>) messages  
(Receipt P to F)**

Item	MAC control (M <sub>T</sub> ) messages	Reference	Status
1	Basic connection control	ETS 300 444 [8], subclause 10.4	C1
3	Advanced connection control	ETS 300 175-3 [3], subclause 7.2.5.1	C2

**Table F.7: ETS 300 474-2 [14], Table A.129: MAC control (M<sub>T</sub>) messages  
(Sending F to P)**

Item	MAC control (M <sub>T</sub> ) messages	Prof. Ref.	Prof. Status
1	Basic connection control	ETS 300 444 [8], subclause 10.4	C1
3	Advanced connection control	ETS 300 175-3 [3], subclause 7.2.5.1	C2

## F.2 Service D2; FT Protocol Implementation Conformance Statement (PICS) proforma - Medium Access Control (MAC) layer

Notwithstanding the provisions of the copyright clause related to the text of the present document, ETSI grants that users of the present document may freely reproduce the PICS proforma in this clause so that it can be used for its intended purposes and may further publish the completed PICS.

The requirements indicated in ETS 300 476-6 [18] shall apply, except for the modifications and/or additions listed below:

**Table F.8: ETS 300 476-6 [18], Table A.11: Connection services**

Item	Connection services	Reference	Status	Support
1	Connection setup (Advanced connections)	ETS 300 444 [8], subclause 10.2	C2	
2	Connection modification (Advanced connections)	ETS 300 444 [8], subclause 10.3	C2	
3	Connection data transfer (Advanced connections)	ETS 300 444 [8], subclause 10.8	C2	
4	Connection release (Advanced connections)	ETS 300 444 [8], subclause 10.4	C2	

**Table F.9: ETS 300 476-6 [18], Table A.57: System Information (QT) message  
(Sending F to P)**

Item	System information message	Reference	Status	Support
4	Q <sub>T</sub> - Extended fixed part capabilities	ETS 300 175-3 [3], subclause 7.2.3.5	m	

**Table F.10: ETS 300 476-6 [18], Table A.66: Advanced connection control messages  
(Receipt P to F)**

Item	MAC control (M <sub>T</sub> ) messages - Advanced connection control	Reference	Status	Support
1	Advanced CC - access request	ETS 300 175-3 [3], subclause 7.2.5.3.2	C2	
2	Advanced CC - bearer handover request	ETS 300 175-3 [3], subclause 7.2.5.3.3	C2	
3	Advanced CC - connection handover request	ETS 300 175-3 [3], subclause 7.2.5.3.4	C2	
5	Advanced CC - bearer confirm	ETS 300 175-3 [3], subclause 7.2.5.3.6	C2	
6	Advanced CC - wait	ETS 300 175-3 [3], subclause 7.2.5.3.7	C2	
7	Advanced CC - attributes_T.request	ETS 300 175-3 [3], subclause 7.2.5.3.8	C2	
8	Advanced CC - attributes_T.confirm	ETS 300 175-3 [3], subclause 7.2.5.3.8	C2	
14	Advanced CC - release	ETS 300 175-3 [3], subclause 7.2.5.3.13	C2	

**Table F.11: ETS 300 476-6 [18], Table A.67: Advanced connection control messages  
(Sending F to P)**

Item	MAC control (M <sub>T</sub> ) messages - Advanced connection control	Reference	Status	Support
1	Advanced CC - access request	ETS 300 175-3 [3], subclause 7.2.5.3.2	C2	
2	Advanced CC - bearer handover request	ETS 300 175-3 [3], subclause 7.2.5.3.3	x	
3	Advanced CC - connection handover request	ETS 300 175-3 [3], subclause 7.2.5.3.4	C2	
5	Advanced CC - bearer confirm	ETS 300 175-3 [3], subclause 7.2.5.3.6	C2	
6	Advanced CC - wait	ETS 300 175-3 [3], subclause 7.2.5.3.7	C2	
7	Advanced CC - attributes_T.request	ETS 300 175-3 [3], subclause 7.2.5.3.8	C2	
8	Advanced CC - attributes_T.confirm	ETS 300 175-3 [3], subclause 7.2.5.3.8	C2	
14	Advanced CC - release	ETS 300 175-3 [3], subclause 7.2.5.3.13	C2	

**Table F.12: ETS 300 476-6 [18], Table A.130: Advanced CC - access request  
(Receipt P to F)**

Item	Advanced CC - access request	Reference	Status	Support	Value allowed	Value supported
1	M <sub>T</sub> header	ETS 300 175-3 [3], subclause 7.2.5.3.2	C2		"0001"B	
2	Command	ETS 300 175-3 [3], subclause 7.2.5.3.2	C2		"0000"B	
3	FMID	ETS 300 175-3 [3], subclause 7.2.5.3.2	C2		12 bits value	
4	PMID	ETS 300 175-3 [3], subclause 7.2.5.3.2	C2		20 bits value	

**Table F.13: ETS 300 476-6 [18], Table A. 131: Advanced CC - access request  
(Sending F to P)**

Item	Advanced CC - access request	Reference	Status	Support	Value allowed	Value supported
1	M <sub>T</sub> header	ETS 300 175-3 [3], subclause 7.2.5.3.2	C2		"0001"B	
2	Command	ETS 300 175-3 [3], subclause 7.2.5.3.2	C2		"0000"B	
3	FMID	ETS 300 175-3 [3], subclause 7.2.5.3.2	C2		12 bits value	
4	PMID	ETS 300 175-3 [3], subclause 7.2.5.3.2	C2		20 bits value	

**Table F.14: ETS 300 476-6 [18], Table A.132: Advanced CC - bearer handover request  
(Receipt P to F)**

Item	Advanced CC - bearer handover request	Reference	Status	Support	Value allowed	Value supported
1	M <sub>T</sub> header	ETS 300 175-3 [3], subclause 7.2.5.3.3	C2		"0001"B	
2	Command	ETS 300 175-3 [3], subclause 7.2.5.3.3	C2		"0001"B	
3	FMID	ETS 300 175-3 [3], subclause 7.2.5.3.3	C2		12 bits value	
4	PMID	ETS 300 175-3 [3], subclause 7.2.5.3.3	C2		20 bits value	

**Table F.15: ETS 300 476-6 [18], Table A. 133: Advanced CC - connection handover request  
(Receipt P to F)**

Item	Advanced CC - connection handover request	Reference	Status	Support	Value allowed	Value supported
1	M <sub>T</sub> header	ETS 300 175-3 [3], subclause 7.2.5.3.4	C2		"0001"B	
2	Command	ETS 300 175-3 [3], subclause 7.2.5.3.4	C2		"0010"B	
3	FMID	ETS 300 175-3 [3], subclause 7.2.5.3.4	C2		12 bits value	
4	PMID	ETS 300 175-3 [3], subclause 7.2.5.3.4	C2		20 bits value	

**Table F.16: ETS 300 476-6 [18], Table A.134: Advanced CC - connection handover request  
(Sending F to P)**

Item	Advanced CC - connection handover request	Reference	Status	Support	Value allowed	Value supported
1	M <sub>T</sub> header	ETS 300 175-3 [3], subclause 7.2.5.3.4	C2		"0001"B	
2	Command	ETS 300 175-3 [3], subclause 7.2.5.3.4	C2		"0010"B	
3	FMID	ETS 300 175-3 [3], subclause 7.2.5.3.4	C2		12 bits value	
4	PMID	ETS 300 175-3 [3], subclause 7.2.5.3.4	C2		20 bits value	

**Table F.17: ETS 300 476-6 [18], Table A.137: Advanced CC - bearer confirm (Receipt P to F)**

Item	Advanced CC - bearer confirm	Reference	Status	Support	Value allowed	Value supported
1	M <sub>T</sub> header	ETS 300 175-3 [3], subclause 7.2.5.3.6	C2		"0001"B	
2	Command	ETS 300 175-3 [3], subclause 7.2.5.3.6	C2		"0100"B	
3	FMID	ETS 300 175-3 [3], subclause 7.2.5.3.6	C2		12 bits value	
4	PMID	ETS 300 175-3 [3], subclause 7.2.5.3.6	C2		20 bits value	

**Table F.18: ETS 300 476-6 [18], Table A.138: Advanced CC - bearer confirm (Sending F to P)**

Item	Advanced CC - bearer confirm	Reference	Status	Support	Value allowed	Value supported
1	M <sub>T</sub> header	ETS 300 175-3 [3], subclause 7.2.5.3.6	C2		"0001"B	
2	Command	ETS 300 175-3 [3], subclause 7.2.5.3.6	C2		"0100"B	
3	FMID	ETS 300 175-3 [3], subclause 7.2.5.3.6	C2		12 bits value	
4	PMID	ETS 300 175-3 [3], subclause 7.2.5.3.6	C2		20 bits value	

**Table F.19: ETS 300 476-6 [18], Table A.139: Advanced CC - wait (Receipt P to F)**

Item	Advanced CC - wait	Reference	Status	Support	Value allowed	Value supported
1	M <sub>T</sub> header	ETS 300 175-3 [3], subclause 7.2.5.3.7	C2		"0001"B	
2	Command	ETS 300 175-3 [3], subclause 7.2.5.3.7	C2		"1111"B	
3	FMID	ETS 300 175-3 [3], subclause 7.2.5.3.7	C2		12 bits value	
4	PMID	ETS 300 175-3 [3], subclause 7.2.5.3.7	C2		20 bits value, "11110000 11110000 1111"B	

**Table F.20: ETS 300 476-6 [18], Table A.140: Advanced CC - wait (Sending F to P)**

Item	Advanced CC - wait	Reference	Status	Support	Value allowed	Value supported
1	M <sub>T</sub> header	ETS 300 175-3 [3], subclause 7.2.5.3.7	C2		"0001"B	
2	Command	ETS 300 175-3 [3], subclause 7.2.5.3.7	C2		"1111"B	
3	FMID	ETS 300 175-3 [3], subclause 7.2.5.3.7	C2		12 bits value	
4	PMID	ETS 300 175-3 [3], subclause 7.2.5.3.7	C2		20 bits value, "11110000 11110000 1111"B	

---

## Annex G (normative): Service D2; PT Profile Implementation Conformance Statement (ICS) - Data Link Control (DLC) layer

### G.1 C-plane

The requirements indicated in ETS 300 474-1 [13], clause A.3 shall apply.

---

### G.2 U-plane

#### G.2.1 U-plane 32 kbit/s unprotected service

The requirements indicated in ETS 300 474-1 [13], clause A.3 shall apply.

#### G.2.2 U-plane unprotected rate adaptation service

No Profile ICS tables have been defined for the DLC U-plane.

The functionalities required are described in annex A of the present document.



---

## Annex H (normative): Service D2; FT Profile Implementation Conformance Statement (ICS) - Data Link Control (DLC) layer

### H.1 C-plane

The requirements indicated in ETS 300 474-2 [14], clause A.3 shall apply.

---

### H.2 U-plane

#### H.2.1 U-plane 32 kbit/s unprotected service

The requirements indicated in ETS 300 474-2 [14], clause A.3 shall apply.

#### H.2.2 U-plane unprotected rate adaptation service

No Profile ICS tables have been defined for the DLC U-plane.

The functionalities required are described in annex A of the present document.

## Annex J (normative): Service D2; PT profile Requirement List (profile RL) and Protocol Implementation Conformance Statement (PICS) proforma - Network (NWK) layer

### Profile status column

The standardized symbols for the status column are as follows:

- m or M      mandatory - the capability is required to be supported.
- o or O      optional - the capability may be supported or not.
- n/a or N/A    not applicable - in the given context, it is impossible to use the capability.
- x or X      prohibited (excluded) - there is a requirement not to use this capability in the given context.
- o.i or O.i    qualified optional - for mutually exclusive or selectable options from a set. "i" is an integer which identifies a unique group of related optional items and the logic of their selection which is defined immediately following the table.
- ci or Ci     conditional - the requirement on the capability ("m", "o", "x" or "n/a") depends on the support of other optional or conditional items. "i" is an integer identifying a unique conditional status expression which is defined immediately following the table or which is defined in the general condition table below.
- i or I      out-of-scope - this capability is outside the scope of the given specification, and hence irrelevant and not subject to conformance testing. This status is in particular applicable for data fields which are reserved for future use. The structure of such fields has to be supported, but the value is undefined and thus to be ignored.

## J.1 Service D2; PT profile Requirement List (profile RL) - Network (NWK) layer

The requirements indicated in ETS 300 474-1 [13], clause A.2 shall apply, except for the modifications and/or additions listed below:

**Table J.1: ETS 300 474-1 [13], Table A.14: CC-SETUP sending (P to F) supported**

Item	CC-SETUP sending (P to F) Information element name	Reference	Status
5	IWU attributes	ETS 300 175-5 [5], subclause 7.7.2.1	m

**Table J.2: ETS 300 474-1 [13], Table A.15: CC-SETUP receiving (F to P) supported**

Item	CC-SETUP receiving (F to P) Information element name	Reference	Status
5	IWU attributes	ETS 300 175-5 [5], subclause 7.7.2.1	m

**Table J.3: ETS 300 474-1 [13], Table A.25: CC-RELEASE sending (P to F) supported**

Item	CC-RELEASE sending (P to F) Information element name	Reference	Status
2	Release reason	ETS 300 444 [8], subclause 8.9	m

**Table J.4: ETS 300 474-1 [13], Table A.26: CC-RELEASE receiving (F to P) supported**

Item	CC-RELEASE receiving (F to P) Information element name	Reference	Status
2	Release reason	ETS 300 444 [8], subclause 8.9	m

**Table J.5: ETS 300 474-1 [13], Table A.27: CC-RELEASE-COM sending (P to F) supported**

Item	CC-RELEASE-COM sending (P to F) Information element name	Reference	Status
2	Release reason	ETS 300 444 [8], subclause 8.9	m

**Table J.6: ETS 300 474-1 [13], Table A.28: CC-RELEASE-COM receiving (F to P) supported**

Item	CC-RELEASE-COM receiving (F to P) Information element name	Reference	Status
2	Release reason	ETS 300 444 [8], subclause 8.9	m

**Table J.7: ETS 300 474-1 [13], Table A.60: Basic service - Normal call set-up supported**

Item	Basic service - Normal call set-up Name of field	Reference	Status	Value allowed
3	Basic service	ETS 300 444 [8], subclause 8.2	m	'1111'B

**Table J.8: ETS 300 474-1 [13], Table A.66: Release-reason supported**

Item	Release-reason Name of field	Reference	Status	Value allowed
2	Release reason code	ETS 300 444 [8], subclause 8.9	m	-

---

## J.2 Service D2; PT Protocol Implementation Conformance Statement (PICS) proforma - Network (NWK) layer

Notwithstanding the provisions of the copyright clause related to the text of the present document, ETSI grants that users of the present document may freely reproduce the PICS proforma in this clause so that it can be used for its intended purposes and may further publish the completed PICS.

The requirements indicated in ETS 300 476-1 [15] shall apply, except for the modifications and/or additions listed below:

**Table J.9: ETS 300 476-1 [15], Table A.24: LLME procedures supported**

Item	LLME procedures	Reference	Status	Support
2	mgt_exchanged_attribute_negotiation	ETS 300 444 [8], subclause 15.2.3	m	

---

## Annex K (normative): Service D2; FT profile Requirement List (profile RL) and Protocol Implementation Conformance Statement (PICS) proforma - Network (NWK) layer

### Profile status column

The standardized symbols for the status column are as follows:

m or M	mandatory - the capability is required to be supported.
o or O	optional - the capability may be supported or not.
n/a or N/A	not applicable - in the given context, it is impossible to use the capability.
x or X	prohibited (excluded) - there is a requirement not to use this capability in the given context.
o.i or O.i	qualified optional - for mutually exclusive or selectable options from a set. "i" is an integer which identifies a unique group of related optional items and the logic of their selection which is defined immediately following the table.
ci or Ci	conditional - the requirement on the capability ("m", "o", "x" or "n/a") depends on the support of other optional or conditional items. "i" is an integer identifying a unique conditional status expression which is defined immediately following the table or which is defined in the general condition table below.
i or I	out-of-scope - this capability is outside the scope of the given specification, and hence irrelevant and not subject to conformance testing. This status is in particular applicable for data fields which are reserved for future use. The structure of such fields has to be supported, but the value is undefined and thus to be ignored.

## K.1 Service D2; FT profile Requirement List (profile RL) - Network (NWK) layer

The requirements indicated in ETS 300 474-2 [14], clause A.2 shall apply, except for the modifications and/or additions listed below:

**Table K.1: ETS 300 474-2 [14], Table A.27: CC-SETUP sending (P to F) supported**

Item	CC-SETUP sending (P to F) Information element name	Reference	Status
5	IWU attributes	ETS 300 175-5 [5], subclause 7.7.2.1	m

**Table K.2: ETS 300 474-2 [14], Table A.28: CC-SETUP sending (F to P) supported**

Item	CC-SETUP sending (F to P) Information element name	Reference	Status
5	IWU attributes	ETS 300 175-5 [5], subclause 7.7.2.1	m

**Table K.3: ETS 300 474-2 [14], Table A.25: CC-RELEASE receiving (P to F) supported**

Item	CC-RELEASE receiving (P to F) Information element name	Reference	Status
2	Release reason	ETS 300 444 [8], subclause 8.9	m

**Table K.4: ETS 300 474-2 [14], Table A.26: CC-RELEASE sending (F to P) supported**

Item	CC-RELEASE sending (F to P) Information element name	Reference	Status
2	Release reason	ETS 300 444 [8], subclause 8.9	m

**Table K.5: ETS 300 474-2 [14], Table A.28: CC-RELEASE-COM sending (F to P) supported**

Item	CC-RELEASE-COM sending (F to P) Information element name	Reference	Status
2	Release reason	ETS 300 444 [8], subclause 8.9	m

**Table K.6: ETS 300 474-2 [14], Table A.61: Basic service - Normal call set-up supported**

Item	Basic service - Normal call set-up Name of field	Reference	Status	Value allowed
3	Basic service	ETS 300 444 [8], subclause 8.2	m	'1111'B

**Table K.7: ETS 300 474-2 [14], Table A.66: Release-reason supported**

Item	Release-reason Name of field	Reference	Status	Value allowed
2	Release reason code	ETS 300 444 [8], subclause 8.9	m	-

## K.2 Service D2; FT Protocol Implementation Conformance Statement (PICS) proforma - Network (NWK) layer

Notwithstanding the provisions of the copyright clause related to the text of the present document, ETSI grants that users of the present document may freely reproduce the PICS proforma in this clause so that it can be used for its intended purposes and may further publish the completed PICS.

The requirements indicated in ETS 300 476-4 [17] shall apply, except for the modifications and/or additions listed below:

**Table K.8: ETS 300 476-4 [17], Table A.24: LLME procedures supported**

Item	LLME procedures	Reference	Status	Support
2	mgt_exchanged_attribute_negotiation	ETS 300 444 [8], subclause 15.2.3	m	

**Table K.9: ETS 300 476-4 [17], Table A.40: CC-RELEASE-COM receiving (P to F) supported**

Item	CC-RELEASE-COM receiving (P to F) Information element name	Reference	Status	Support
2	Release reason	ETS 300 444 [8], subclause 7.6.7	m	

---

## History

<b>Document history</b>		
V1.1.1	August 1997	Public Enquiry PE 9748: 1997-08-01 to 1997-11-28