

Draft **EN 301 163-1-1** V1.1.1 (1998-05)

European Standard (Telecommunications series)

**Transmission and Multiplexing (TM);
Generic requirements of Asynchronous Transfer Mode (ATM)
transport functionality within equipment;
Part 1-1: Functional characteristics
and equipment performance**



Reference

DEN/TM-01016-1-1 (aro99ico.PDF)

Keywords

ATM, transport, B-ISDN, SDH, transmission

ETSI

Postal address

F-06921 Sophia Antipolis Cedex - FRANCE

Office address

650 Route des Lucioles - Sophia Antipolis
Valbonne - FRANCE
Tel.: +33 4 92 94 42 00 Fax: +33 4 93 65 47 16
Siret N° 348 623 562 00017 - NAF 742 C
Association à but non lucratif enregistrée à la
Sous-Préfecture de Grasse (06) N° 7803/88

Internet

secretariat@etsi.fr
<http://www.etsi.fr>
<http://www.etsi.org>

Copyright Notification

No part may be reproduced except as authorized by written permission.
The copyright and the foregoing restriction extend to reproduction in all media.

© European Telecommunications Standards Institute 1998.
All rights reserved.

Contents

Intellectual Property Rights.....	6
Foreword	6
1 Scope.....	7
2 Normative references	7
3 Definitions and abbreviations	9
3.1 Definitions	9
3.2 Abbreviations.....	9
4 Introduction.....	10
5 Functional model and processes	11
5.1 The ITU-T Recommendation I.732 functional model.....	11
5.1.1 Allocation of process to ITU-T Recommendation I.732 functional blocks.....	12
5.2 EN 301 163-2-1 formal model.....	17
5.2.1 Symbols and diagrammatic conventions	17
5.2.2 Functional modelling rationale.....	17
5.2.2.1 Description of NEs - equipment functional specification	17
5.2.2.2 Implementation independence	18
5.2.2.3 Universal representation for management	18
5.2.3 The underlying principles of functional modelling	18
5.2.3.1 The client-server relationship	18
5.2.3.2 Atomic functions and compound functions	19
5.2.3.3 Network functions included in specific equipment.....	19
5.2.3.4 The functional model and the information model.....	19
5.2.4 Network layering principles	20
6 Connectivity capabilities.....	21
6.1 Introduction.....	21
6.2 Number of connections supported	23
6.3 Point-to-point connections	23
6.4 Point-to-multipoint connections.....	24
6.4.1 Overview	24
6.4.2 Definitions.....	24
6.4.2.1 ATM cell multicast.....	24
6.4.2.2 Spatial multicast	24
6.4.2.3 Logical multicast	24
6.5 Multipoint to point connections	25
6.5.1 Merging is different from multiplexing.....	25
6.5.2 The Use of merging.....	25
6.5.2.1 Identification of the information at higher layer(s).....	25
6.5.3 Merging scheme	25
6.5.4 Bypassing merging	26
6.6 Multipoint to multipoint connections.....	27
6.7 OAM aspects of multipoint connections.....	27
6.8 Permanent virtual connections	27
6.8.1 Hard PVCs	27
6.8.2 Soft PVCs.....	27
6.9 Switched virtual connections	28
6.10 Support for different media upstream/downstream.....	28
7 OAM functions	28
7.1 OAM naming conventions for ATM.....	28
7.2 OAM procedures	29
7.2.1 AIS application.....	29
7.2.1.1 RDI application	29
7.2.1.1.1 CC application	29

8	Traffic and congestion control functions	29
9	Signalling	29
10	Resource control functions	29
10.1	ATM resource requests to be processed by an ATM equipment	30
10.1.1	Establishing or releasing a VP or VC connection	30
10.2	General ATM equipment features for processing an ATM request	31
10.2.1	Processing of modification request messages	31
10.2.2	CAC function	31
10.3	Management, signalling, RM applications	32
10.4	CAC	32
10.4.1	SAC	35
10.4.1.1	SLAD	35
10.4.1.1.1	Description	35
10.4.1.1.2	Configuration of the SLAD	36
10.4.1.2	Routing function	36
10.4.1.2.1	Definitions	36
10.4.1.2.2	Input parameters of the routing process	38
10.4.1.2.3	Output parameters of the routing process	38
10.4.1.2.4	Configuration of the routing function	38
10.4.2	EAC function	38
10.4.2.1	Resource of an ATM equipment	38
10.4.2.2	EAC process	39
10.4.2.3	Configuration of the EAC function	39
10.5	The processing steps of an ATM request	40
10.5.1	Request to establish or release an ATM VP or VC connection	40
10.5.2	Request to modify the traffic characteristics of an existing ATM VP or VC connection	40
10.6	Method for reducing outages on resource modification	41
11	Traffic measurement functions	41
11.1	Traffic information collection	41
11.1.1	TP usage measurement	41
11.1.2	ATM cell level protocol performance information collection	42
11.1.3	VP/VC traffic load information collection	42
11.1.4	VP/VC UPC/NPC information collection	42
11.1.5	Call level information collection	43
12	NE performance	43
12.1	ATM layer cell transfer performance	43
12.2	Semi-permanent connection availability	46
12.3	Call processing performance	46
13	Availability and reliability	48
13.1	Availability objectives	48
13.1.1	General	48
13.1.2	Parameters	48
13.1.3	Derivation of MTBF values	49
13.2	Data integrity	49
13.3	Upgrade	50
13.4	Start-up requirements	50
14	Protections switching on ATM layer	50
15	AEMF	51
15.1	Co-ordination between Layer Management functions	51
15.2	Reports to the AEMF	51
16	Timing	51
16.1	User plane related timing	51
16.1.1	Timing accuracy	51
16.1.2	Equipment timing source	51
16.1.3	Timing of the TP layers	51

16.2	Management of plane related timing.....	52
17	General characteristics	52
17.1	Management interfaces	52
17.2	Power supply.....	52
17.3	Physical requirements	52
17.4	Environmental requirements	52
17.5	Electrical/Optical safety requirements	52
17.6	Equipment practice	52
18	Application requirements.....	53
Annex A (informative): AIS application		54
A.1	AIS application	54
A.1.1	AIS definition	54
A.1.2	AIS flow.....	54
A.1.3	AIS generation control.....	56
Bibliography		59
History		60

Intellectual Property Rights

IPRs essential or potentially essential to the present document may have been declared to ETSI. The information pertaining to these essential IPRs, if any, is publicly available for **ETSI members and non-members**, and can be found in ETR 314: "*Intellectual Property Rights (IPRs); Essential, or potentially Essential, IPRs notified to ETSI in respect of ETSI standards*", which is available **free of charge** from the ETSI Secretariat. Latest updates are available on the ETSI Web server (<http://www.etsi.fr/ipr> or <http://www.etsi.org/ipr>).

Pursuant to the ETSI Interim IPR Policy, no investigation, including IPR searches, has been carried out by ETSI. No guarantee can be given as to the existence of other IPRs not referenced in ETR 314 (or the updates on the ETSI Web server) which are, or may be, or may become, essential to the present document.

Foreword

This European Standard (Telecommunications series) has been produced by ETSI Technical Committee Transmission and Multiplexing (TM), and is now submitted for the Public Enquiry phase of the ETSI standards two-step Approval Procedure.

The present document consists of 2 parts as follows:

Part 1: "Functional characteristics and equipment performance";

Part 2: "Functional model for the transfer and layer management plane".

Proposed national transposition dates	
Date of latest announcement of this EN (doa):	3 months after ETSI publication
Date of latest publication of new National Standard or endorsement of this EN (dop/e):	6 months after doa
Date of withdrawal of any conflicting National Standard (dow):	6 months after doa

1 Scope

The purpose of the present document is to provide specifications for ATM equipment to be used in the ETSI region. These specifications seek to define the processes associated with ATM rather than specific equipment types. Such specifications will ensure compatibility between equipment by identifying which functions within a process are mandatory for interworking and which can be considered as truly optional. It is not the intention to prevent manufacturers or procurers from following an alternative specification, but the consequences should become clear from this specification.

The ETSI ATM Equipment specification will be in two parts. The first part (the present document) being more conceptual, producing a list of functions and processes and some guidance to the ITU model and the ETSI functional mode. The second part (EN 301 163-2-1 [17]) is a formal representation of transfer and layer management functions in the form of a library of atomic functions. This will provide flexibility since many equipment types may be defined by using these atomic functions in different combinations.

The specification will take advantage of the work done in ITU but will take the work further with an ETSI view. This means: the identification of ITU options that has to be mandatory in the ETSI region, deletion of options not required for the ETSI region, creation of new or revised descriptions where necessary, identification of guideline or benchmark performance parameters for classes of equipment.

2 References

The following documents contain provisions which, through reference in this text, constitute provisions of the present document.

- References are either specific (identified by date of publication, edition number, version number, etc.) or non-specific.
- For a specific reference, subsequent revisions do not apply.
- For a non-specific reference, subsequent revisions do apply.
- A non-specific reference to an ETS shall also be taken to refer to later versions published as an EN with the same number.

- [1] ETS 300 019-1-0: "Equipment Engineering (EE); Environmental conditions and environmental tests for telecommunications equipment; Part 1-0: Classification of environmental conditions. Introduction".
- [2] ETS 300 119: "Equipment Engineering (EE); European telecommunication standard for equipment practice; Part 1: Introduction and terminology".
- [3] ETS 300 132-1: "Equipment Engineering (EE); Power supply interface at the input to telecommunications equipment; Part 1: Operated by alternating current (ac) derived from direct current (dc) sources".
- [4] ETS 300 132-2: "Equipment Engineering (EE); Power supply interface at the input to telecommunications equipment; Part 2: Operated by direct current (dc)".
- [5] ETS 300 150: "Transmission and Multiplexing (TM); Protocol suites for Q interfaces for management of transmission systems".
- [6] ETS 300 253: "Equipment Engineering (EE); Earthing and bonding of telecommunication equipment in telecommunication centres".
- [7] ETS 300 301: "Broadband Integrated Services Digital Network (B-ISDN); Traffic control and congestion control in B-ISDN".
- [8] ETS 300 304: "Transmission and Multiplexing (TM); Synchronous Digital Hierarchy (SDH) information model for the Network Element (NE) view".

- [9] ETS 300 386-1: "Equipment Engineering (EE); Telecommunication network equipment; Electro-Magnetic Compatibility (EMC) requirements Part 1: Product family overview, compliance criteria and test levels".
- [10] ETS 300 386-2: "Electromagnetic compatibility and Radio spectrum Matters (ERM); Telecommunication network equipment; ElectroMagnetic Compatibility (EMC) requirements; Part 2: Product family standard".
- [11] ETS 300 404: "Broadband Integrated Services Digital Network (B-ISDN); B-ISDN Operation And Maintenance (OAM) principles and functions".
- [12] ETS 300 417: "Transmission and Multiplexing (TM); Generic functional requirements for Synchronous Digital Hierarchy (SDH) equipment".
- [13] ETS 300 417-1-1: "Transmission and Multiplexing (TM); Generic functional requirements for Synchronous Digital Hierarchy (SDH) equipment; Part 1–1: Generic processes and performance".
- [14] ETS 300 417-6-1: "Transmission and Multiplexing (TM); Generic requirements of transport functionality of equipment; Part 6–1: Synchronous layer functions".
- [15] ETS 300 462: "Transmission and Multiplexing (TM); Generic requirements for synchronization networks; Part 1: Definitions and terminology for synchronization networks".
- [16] ETS 300 469: "Broadband Integrated Services Digital Network (B-ISDN); Asynchronous Transfer Mode (ATM); Management of the network element view [ITU–T Recommendation I.751 (1996)]".
- [17] EN 301 163–2–1: "Transmission and Multiplexing (TM); Generic requirements of Asynchronous Transfer Mode (ATM) transport functionality within equipment; Part 2–1: Functional model for the transfer and layer management plane".
- [18] ITU-T handbook: "Handbook on Quality of Service and Network Performance".
- [19] ITU-T Recommendation E.862: "Dependability planning of telecommunication networks".
- [20] ITU Recommendation I.150: "B-ISDN asynchronous transfer mode functional characteristics".
- [21] ITU-T Recommendation I.321: "B-ISDN protocol reference model and its application".
- [22] ITU-T Recommendation I.326: "Functional architecture of transport networks based on ATM".
- [23] ITU-T Recommendation I.353: "Reference events for defining ISDN and B-ISDN performance parameters".
- [24] ITU-T Recommendation I.356: "B-ISDN ATM layer cell transfer performance".
- [25] ITU-T Recommendation I.357: "B-ISDN semi-permanent connection availability".
- [26] ITU-T Recommendation I.358: "Call Processing Performance for Switched Virtual Channel Connections (VCCs) in B-ISDN".
- [27] ITU-T Recommendation I.371: "Traffic control and congestion control in B-ISDN".
- [28] ITU-T Recommendation I.432: "B-ISDN user-network interface - Physical layer specification".
- [29] ITU-T Recommendation I.610: "B-ISDN operation and maintenance principles and functions".
- [30] ITU-T Recommendation I.731: "Types and general characteristics of ATM equipment".
- [31] ITU-T Recommendation I.732: "Functional characteristics of ATM equipment".
- [32] ITU-T Recommendation G.803: "Architecture of transport networks based on the synchronous digital hierarchy (SDH)".
- [33] ITU-T Recommendation G.805: "Generic functional architecture of transport networks".

- [34] ITU-T Recommendation G.911: "Parameters and calculation methodologies for reliability and availability of fibre optic systems".
- [35] ITU-T Recommendation O.191: "Equipment to assess ATM layer cell transfer performance".
- [36] ITU-T Recommendation Q.2100: "B-ISDN signalling ATM adaptation layer (SAAL) overview description".
- [37] ITU-T Recommendation X.721: "Information technology - Open Systems Interconnection - Structure of management information: Definition of management information".
- [38] IEC 825-2: "Safety of laser products - Part 2: Safety of optical fibre communications systems".

3 Definitions and abbreviations

3.1 Definitions

The functional definitions are described in ETS 300 417-1-1 [13].

3.2 Abbreviations

For the purposes of the present document, the following abbreviations apply:

AAL	ATM Adaptation Layer
AD	Activation/Deactivation
AEMF	ATM Equipment Management Function
AIS	Alarm Indication Signal
ATC	ATM Transport Capability
ATM	Asynchronous Transfer Mode
BBCC	Broadband Bearer Channel Control
BISUP	Broadband ISDN Users Part
CAC	Connection Admission Control
CC	Continuity Check
CDV	Cell Delay Variation
CER	Cell Error Ratio
CLP	Cell Loss Priority
CLR	Cell Loss Ratio (CLR ₀ , CLR ₀₊₁ , CLR ₁)
CMR	Cell Misinsertion Rate
EAC	Equipment Admission Control
EFCI	Explicit Forward Congestion Indication
EFS	Equipment Functional Specification
e-to-e	End-to-End
F4E OAM	F4 End-to-End OAM
F4S OAM	F4 Segment OAM
F5E OAM	F5 End-to-End OAM
F5S OAM	F5 Segment OAM
FIT	Failure In Time
FM	Fault Management
GFC	Generic Flow Control
HEC	Header Error Control
IAM	Initial Address Message (signalling)
IWF	InterWorking Function
LB	Loopback
LCD	Loss of Cell Delineation
LOC	Loss Of Continuity
MCF	Message Communication Function
MCTD	Mean Cell Transfer Delay
MTBF	Mean Time Between Failures

MTBO	Mean Time Between Outages
NE	Network Element
NMS	Network Management System
NNI	Network Node Interface
NPC	Network Parameter Control
OI	Outage Intensity
PDU	Protocol Data Unit
PM	Performance Management/Performance Monitoring
POH	Path Overhead
PTI	Payload Type Indicator
QoS	Quality of Service
RDI	Receive Defect Indication
RM	Resource Management
SAC	Service Admission Control
SAAL	Signalling AAL
SECBR	Severely Errored Cell Block Ratio
Seg.	Segment
SLAD	Service Level ADmission
SSF	Server Signal Fail
SSU	Synchronization Supply Unit
TBD	To Be Determined
TP	Transmission Path
TM	Transmission Media
UNI	User Network Interface
UPC	Usage Parameter Control
VC	Virtual Channel
VC-4	Virtual Container level 4
VCC	Virtual Channel Connection
VCI	Virtual Channel Identifier
VP	Virtual Path
VPC	Virtual Path Connection
VPI	Virtual Path Identifier

4 Introduction

The purpose of the present document is to provide specifications for Asynchronous Transfer Mode (ATM) equipment to be used in the ETSI region. It provides an overview of the functions and processes of ATM equipment. The approach of the present document is to have a library of functions and concepts that can be joined together as required to form many different equipment types for many different usages. Where possible, the present document will illustrate with examples how these functions and processes can be modelled using the atomic functions defined in EN 301 163-2-1 [17].

The document has the following themes with some themes relating to more than one clause (For a complete list of clause see the table of contents).

The themes are:

- Modelling techniques and a summary of the approaches in ITU-T Recommendation I.732 [31] and in ETSI TM1;
- Connectivity capabilities;
- OAM functions;
- Traffic management;
- Network Element (NE) performance;
- ATM Equipment Management Function (AEMF);
- Timing (the requirements for synchronization);
- General equipment characteristics (physical & environment requirements).

As the present document is very much linked to the state of the art for ATM technology and its philosophy, some of the clauses are more stable than others.

5 Functional model and processes

This clause describes the functional modelling technique used in ETSI TM1 (ETS 300 417 [12], and the present document). In order to provide an introduction the clause provides information on the work done in ITU-T Recommendation I.732 [31]. The present document has a different treatment to ETSI TM1's model, but should be seen as complimentary rather than duplication since the level of detail in ITU-T Recommendation I.732 [31] is much less but it concentrates more on ordering and sequencing of the functions.

5.1 The ITU-T Recommendation I.732 functional model

This subclause provides a short description of the main broad functional areas of an ATM NE according to ITU-T Recommendation I.732 [31]. Detailed information is provided by ITU-T Recommendations I.731 [30] and I.732 [31].

The main broad functional areas of an ATM NE are:

- the **transfer functions**, corresponding to the physical layers, ATM layer and adaptation to higher layers;
- the **layer management functions**, manages in real time the transfer functions (e.g. traffic enforcement), processes the information from the transfer functions (e.g. OAM processing) and Co-ordination Function; and sends information or instructions to the transfer functions or Co-ordination function;
- the **signalling applications**;
- the **system management**, which notably supports the Q3 interface towards the Network Management System (NMS). It includes the five classical management areas (configuration, fault, performance, accounting and security management). This entity is called the Asynchronous AEMF;
- the **CoF** (Co-ordination Function) supplies:
 - a) the co-ordination between the relevant Layer Management functions at the different layers when required;
 - b) the processing of the requests for resources through the Signalling Applications, the AEMF (Q3 interface), and the Resource Management (RM) protocols (Connection Admission Control (CAC)).
- the **InterWorking Function (IWF)**, which provides interworking between ATM based and other network services supported by the ATM equipment (e.g. Frame Relay, N-ISDN);
- the **Message Communication Function (MCF)**, which performs the exchange of AEMF messages with the NMS, based on an ATM or X.25 transport stack;
- the **Timing** function, which deals with the actions required to synchronize the equipment interfaces to a clock source (internal or external) when required;
- **Protection Switching and restoration**. ATM layer based protection switching and restoration capabilities in ATM NEs is for further study in ITU-T Recommendation I.731 [30] and I.732 [31].

Application-specific functions may also exist in the equipment. The ATM Adaptation Layer (AAL) functions enhance the service provided by the ATM Layer functions to enable the service-specific higher layers to use the service-independent ATM layer. For example in the case of a MPEG-2 video server, specific stacks exist to carry a video signal on an AAL.

- One particular type of AAL service user is the signalling entity wishing to communicate with a peer entity. Each of these entities would require that functions are provided above the common part of the AAL specifically designed to facilitate this task. The AAL functions necessary to support signalling should be in accordance with ITU-T Recommendation Q.2100 [36], B-ISDN Signalling AAL (SAAL).

Figure 1 provides the overall organization of an ATM equipment, with respect to the previous description.

The following clauses provide tables containing a detailed description of the Transfer, the Layer Management and the Co-ordination functions for an ATM NE. Although the following clauses are limited to the ATM aspect, it should be kept in mind that other components exist in an ATM equipment (e.g. SDH-based interfaces and associated management functions).

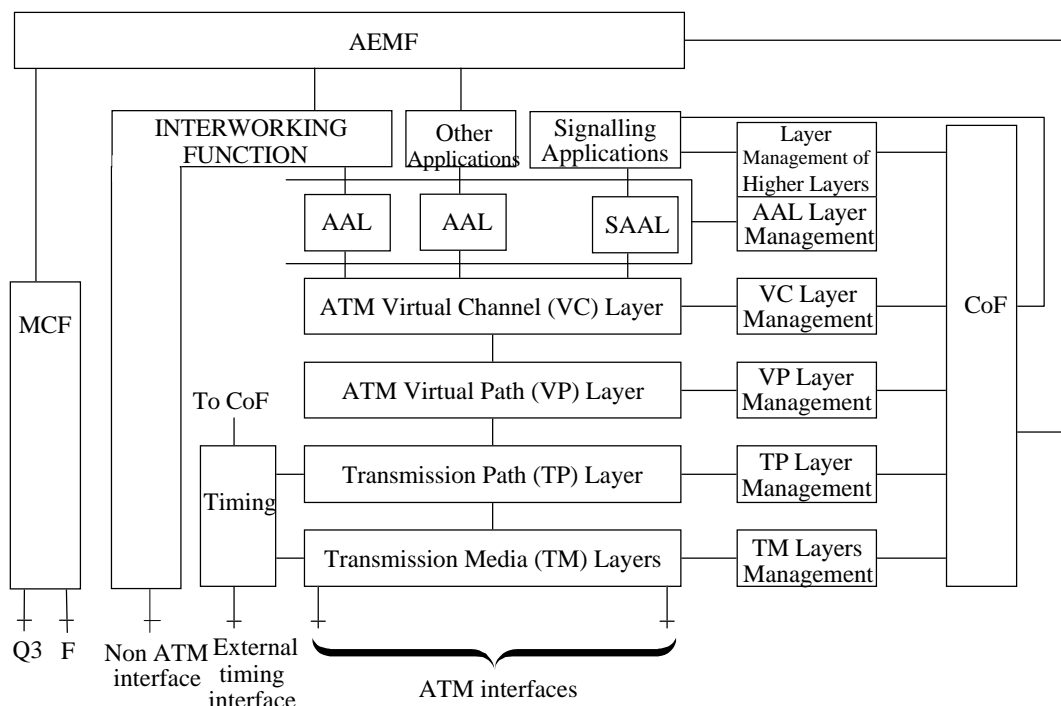

Figure 1: General Overview of ATM Equipment according to ITU-T Recommendation I.731 [30]

5.1.1 Allocation of process to ITU-T Recommendation I.732 functional blocks

The Table 1 and Table 2 mainly cover the transfer plane. Transfer functions are restricted to *insertion*, *extraction* of cells, *writing* or *reading* of fields and *other* operations concerning a set of cells (such as multiplexing and demultiplexing, control, shaping). The tables given below list and arrange these functions and their function types (I, E, W, R, Oth which represent respectively: Insertion, Extraction, Writing, Reading and Other) for B to A and A to B flows. The list is numbered for further identification purpose. The ITU-T Recommendation I.732 [31] blocks are indicated in the first column.

Table 1: Virtual Channel (VC) Level functions

ITU-T Rec.I.732 LEVEL	Process	ITU-T Rec.I.732 B to A direction	ITU-T Rec.I.732 A to B direction
VC_T	1. User indication	(W) if AAL 5, a bit of Payload Type Indicator (PTI) field is used for signalling the end of message	(R) if AAL 5, a bit of PTI field is used for signalling the end of message
	2. F5E End-to-End OAM (F5E OAM) PM	(E) of F5E OAM performance cells - End of OAM Virtual Channel Connection (VCC) performance	(I) of F5E OAM performance cells - Start of OAM VCC performance
	3. F5E OAM CC	(E) of F5E OAM Continuity Check (CC) cells	(I) of F5E OAM CC cells
	4. F5E OAM Activation/Deactivation (AD)	(E) of F5E OAM AD cells	(I) of F5E OAM AD cells

	5.	F5 OAM Receive Defect Indication (RDI)	(E) of F5 OAM RDI cells	(I) of F5 OAM RDI cells
	6.	F5 OAM Alarm Indication Signal (AIS)	(E) of F5 OAM AIS	
	7.	F5E OAM LB at a source point	(E) of F5E OAM LoopBack (LB) cell	(I) of F5E OAM LB cell
	8.	F5E OAM LB at LB point	(E) of F5E OAM LB cell	(I) of LBed F5E OAM LB cell
VC_C	9.	Matrix Connection	(Oth) interconnection of VC links	
VCL_T	10.	F5 OAM AIS	(I) of F5 OAM AIS - Extraction at the VCC termination	(I) of F5 OAM AIS - Extraction at the VCC termination
	11.	F5 OAM AIS/RDI non-intrusive monitoring	(R) of F5 OAM AIS/RDI cells for e-to-e and seg. AIS/RDI processing and reporting	(R) of F5 OAM AIS/RDI cells for e-to-e and seg. AIS/RDI processing and reporting
	12.	F5 Segment (Seg.) OAM (F5S OAM) CC	(I/E) of F5S OAM CC cells	(E/I) of F5S OAM CC cells
	13.	F5S OAM CC non-intrusive monitoring	(Oth) detection of cell arrival	(Oth) detection of cell arrival
	14.	F5S OAM AD	(I/E) of F5S OAM AD cells	(E/I) of F5S OAM AD cells
	15.	F5 OAM LB at a source point	(I) of F5 OAM LB cell or (R) [or optionally (E)] of F5 OAM LB cell	(I) of F5 OAM LB cell or (R) [or optionally (E)] of F5 OAM LB cell
	16.	F5S OAM LB at LB point	(R) [or optionally (E)] of F5S OAM LB cell or (I) of loopbacked F5S OAM LB cell	(R) [or optionally (E)] of F5S OAM LB cell or (I) of loopbacked F5S OAM LB cell
	17.	F5S OAM LB at seg. termination	(E) and discarding of F5S OAM LB cells at OAM seg. termination	(E) and discarding of F5S OAM LB cells at OAM seg. termination
	18.	F5 RM	(R) of F5 RM cells and (E) discarding or (W) setting of specific fields	(I) of F5 RM cells
	19.	F5S OAM PM	(E/I) of F5S OAM performance cells	(I/E) of F5S OAM performance cells
			(continued)	

Table 1 (concluded): Virtual Channel (VC) Level functions

ITU-T Rec.I.732 LEVEL	Process	ITU-T Rec.I.732 B to A direction	ITU-T Rec.I.732 A to B direction
	20. F5 OAM PM non-intrusive monitoring	(R) of F5 OAM performance cells for e-to-e and seg. performance processing and reporting	(R) of F5 OAM performance cells for e-to-e and seg. performance processing and reporting
	21. Shaping	(Oth) shaping of the ATM compliant traffic	(Oth) shaping of the ATM compliant traffic
	22. Usage Parameter Control (UPC)/Network Parameter Control (NPC)	(Oth) compliance checking + (E/W) corrective action if activated	
	23. VC usage Measurement	(Oth) detection and count of incoming cell arrival	(Oth) detection and count of outgoing cells
	24. Explicit Forward Congestion Indication (EFCI) setting		(W) setting of the EFCI bit of the PTI field
	25. Virtual Channel Identifier (VCI) setting		(W) VCI field setting
Virtual Path (VP)/VC_A	26. VC mux	(Oth) demultiplexing of VCs according to the VCI values	(Oth) VC multiplexing
	27. Congestion	(E) and discarding of cells according to Cell Loss Priority (CLP) values or other parameters	(E) and discarding of cells according to CLP values or other parameters
	28. Metasignalling	(E) of metasignalling cells	(I) of metasignalling cells
	29. VCI verification	(R) of VCI field and (E) and discarding of cells with invalid VCI	

Table 2: Virtual Path (VP) level functions

ITU-T Rec.I.732 LEVEL	FUNCTION	ITU-T Recommendation I.732 B to A direction	ITU-T Recommendation I.732 A to B direction
VP_T	30. F4 End-to-End OAM (F4E OAM) PM	(E) of F4E OAM performance cells	(I) of F4E OAM performance cells
	31. F4E OAM CC	(E) of F4E OAM CC cells	(I) of F4E OAM CC cells
	32. F4E OAM AD	(E) of F4E OAM AD cells	(I) of F4E OAM AD cells
	33. F4 OAM RDI	(E) of F4 OAM RDI cells	(I) of F4 OAM RDI cells
	34. F4 OAM AIS	(E) of F4 OAM AIS	
	35. F4E OAM LB at a source point	(E) of F4E OAM LB cell	(I) of F4E OAM LB cell
	36. F4E OAM LB at LB point	(E) of F4E OAM LB cell	(I) of loopbacked F4E OAM LB cell
VP_C	37. Matrix Connection	(Oth) interconnection of VP links	
VPL_T	38. F4 OAM AIS	(I) of F4 OAM AIS	(I) of F4 OAM AIS
	39. F4 OAM AIS/RDI non-intrusive monitoring	(R) of F4 OAM AIS/RDI cells for e-to-e and seg. AIS/RDI processing and reporting	(R) of F4 OAM AIS/RDI cells for e-to-e and seg. AIS/RDI processing and reporting
	40. F4 Seg. OAM (F4S OAM) CC	(I/E) of F4S OAM CC cells	(E/I) of F4S OAM CC cells
	41. F4S OAM CC non-intrusive monitoring	(Oth) detection of cell arrival	(Oth) detection of cell arrival
	42. F4S OAM AD	(I/E) of F4S OAM AD cells	(E/I) of F4S OAM AD cells
	43. F4 OAM LB at a source point	(I) of F4 OAM LB cell or (R) [or optionally (E)] of F4 OAM LB cell	(I) of F4 OAM LB cell or (R) [or optionally (E)] of F4 OAM LB cell
	44. F4S OAM LB at LB point or	(R) [or optionally (E)] of F4S OAM LB cell or (I) of loopbacked F4S OAM LB cell	(R) [or optionally (E)] of F4S OAM LB cell or (I) of loopbacked F4S OAM LB cell
	45. F4S OAM LB at seg. termination	(E) and discarding of F4S OAM LB cells at OAM seg. termination	(E) and discarding of F4S OAM LB cells at OAM seg. termination
	46. F4 RM	(R) of F4 RM cells and (E) discarding or (W) setting of specific fields	(I) of F4 RM cells
	47. F4S OAM PM	(E/I) of F4S OAM performance cells	(I/E) of F4S OAM performance cells
	48. F4 OAM PM non-intrusive monitoring	(R) of F4 OAM performance cells for e-to-e and seg. performance processing and reporting	(R) of F4 OAM performance cells for e-to-e and seg. performance processing and reporting
	49. Shaping	(Oth) shaping of the ATM compliant traffic	(Oth) shaping of the ATM compliant traffic
	50. UPC / NPC	(Oth) compliance checking + (E/W) corrective action if activated	
		(continued)	

Table 2 (concluded): Virtual Path (VP) level functions

ITU-T Rec.I.732 LEVEL	FUNCTION	ITU-T Recommendation I.732 B to A direction	ITU-T Recommendation I.732 A to B direction	
	51. VP usage Measurement	(Oth) detection and count of incoming cell arrival	(Oth) detection and count of outgoing cells	
	52. EFCI setting		(W) setting of the EFCI bit of the PTI field	
	53. Virtual Path Identifier (VPI) setting		(W) VPI field setting	
TP/VP_A	54. VP mux	(Oth) demultiplexing of the VPs according to the VPI values	(Oth) VP multiplexing	
	55. Congestion	(E) and discarding of cells according to CLP values or other parameters	(E) and discarding of cells according to CLP values or other parameters	
	56. VPI verification	(R) of VPI field and (E) and discarding of cells with invalid VPI		
	57. Generic Flow Control (GFC)	(R) of the GFC field	(W) setting of the GFC field in an assigned cell or (I) insertion of an unassigned cell	
	58. Header verification	(R) of header fields and (E) and discarding of cells with invalid header		
	59. TP usage Measurement	(Oth) detection and count of incoming cell arrival	(Oth) detection and count of outgoing cells	
	SAP	60. Cell rate decoupling	(E) and discarding of idle cells	(I) of idle cells
		61. Header Error Control (HEC) processing	(R/W) verification, header correction if applicable (E) and discarding of invalid cells	(W) HEC generation
		62. Scrambling	(R/W) information field descrambling	(R/W) information field scrambling
63. Cell delineation		(Oth) HEC field is used for cell delineation		
64. Mapping		(Oth) ATM flow extraction from Transmission Path (TP) This function does not exist if the interface is "cell based"	(Oth) ATM flow mapping into TP This function does not exist if the interface is "cell based"	

5.2 EN 301 163-2-1 formal model

5.2.1 Symbols and diagrammatic conventions

For a description of the symbols and diagrammatic conventions used in this model refer to ETS 300 417-1-1 [13], subclause 3.4.

5.2.2 Functional modelling rationale

A limited set of atomic functions has been derived by decomposing the European digital transport hierarchies to form the library contained within the present document together with ETS 300 417 [12] for the atomic functions of the Physical Layers. The contents of this library are consistent with the definitions of functions contained in ITU-T Recommendation I.732 [31]. In order to be compliant with the present document, equipment which contains functionality defined within the present document should only use the functions as explicitly defined. As technology evolves, new NEs requiring additional atomic functions may be developed.

Three types of atomic function are required to describe a transmission network. According to ITU-T Recommendation G.805 [33], these are:

- the connection function;
- the adaptation function;
- the termination function.

Each of these functions can be unidirectional or bi-directional. The direction of transmission through an unidirectional function is identified by defining it as a sink or a source function.

5.2.2.1 Description of NEs - equipment functional specification

The present document, EN 301 163-2-1 [17] together with ETS 300 417 [12] specify both the components and the methodology that should be used in order to specify ATM equipment; it does not specify an individual ATM equipment as such. The ETSs form a consistent set which rely on each other on the basis of the layering techniques used as described in e.g. ITU-T Recommendations G.805 [33], I.326 [22] or G.803 [32].

The specification method is based on functional decomposition of the equipment into atomic, compound and major compound functions. The equipment is then described by its Equipment Functional Specification (EFS) which lists the constituent atomic and compound functions, their interconnection, and any overall performance objectives (e.g. transfer delay, availability, etc.). The concept is illustrated in Figure 2.

The internal structure of the implementation of this functionality (equipment design) need not be identical to the structure of the functional model, as long as all the details of the externally observable behaviour comply with the EFS.

Interworking with old equipment may be necessary in a pragmatic network, but this is outside the scope of the present document.

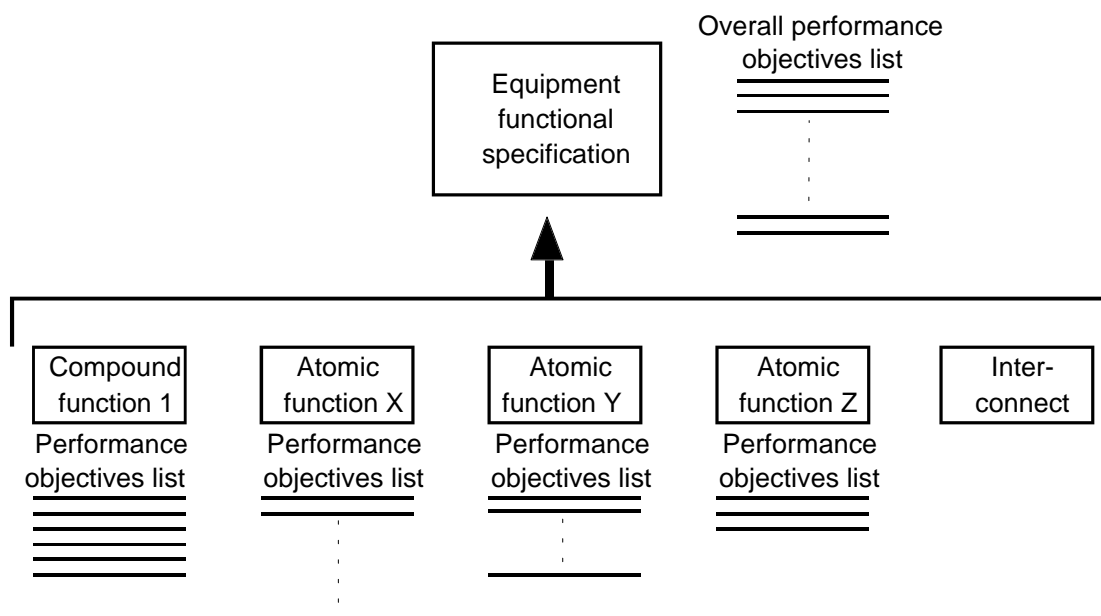

Figure 2: Composition of EFS

5.2.2.2 Implementation independence

The atomic functions and their interconnection in an EFS describe the functionality as it can be observed from the inputs and outputs of the NE. The internal structure of the implementation of this functionality (equipment design) need not be identical to the structure of the functional model, as long as all the details of the externally observable behaviour comply with the EFS.

NOTE: One exception to this implementation independence rule is recognized in the connection function. Refer to ETS 300 417-1-1 [13], subclause 5.2.1.

5.2.2.3 Universal representation for management

Implementation independent descriptions of network functions, such as those given in the present document, form the basis of a generic Information Model for digital transport systems (ETS 300 469 [16]). This Information Model will be applicable to any equipment which is compliant with EN 301 163-2-1 [17]. Different equipment types are therefore built using subsets from the same information and functional model libraries. This modular library approach means that implementation and manufacturer information is reduced to a minimum. (Some manufacturer specific information may be required for repair and maintenance purposes).

5.2.3 The underlying principles of functional modelling

5.2.3.1 The client-server relationship

ITU-T Recommendation G.803 [32] defines a collection of layers which model the digital transmission hierarchy. Each layer is related to the adjacent layer in one of two ways. It either serves the adjacent layer or is served by the adjacent layer. When the layer serves the adjacent layer it is called a server layer and when it is served by the adjacent layer it is called a client layer. Thus, a client/server relationship is established between the layers which describe the digital transport hierarchies. This relationship is recursive. ITU-T Recommendation G.803 [32] describes the generic properties of the layers which describe the digital transmission hierarchy and the functions from which such networks are constructed. The present document gives specific definitions for the equipment functions which form each layer of the European digital transport networks.

5.2.3.2 Atomic functions and compound functions

The main unit of equipment specification is the atomic function, which may be interconnected as discussed in ETS 300 417-1-1 [13], clause 6. Groups of atomic functions within a library of atomic functions may be combined to form compound functions. Functions can also be combined across layer boundaries to form more complex major compound functions. The definitions in the present document are consistent with the definitions contained in ITU-T Recommendation I.732 [31] although in some cases the definitions given in the present document will contain supplementary points of detail. Equipment which is compliant with the present document can be specified by using any valid combination of these compound functions and the atomic functions defined in the present document. The mechanism by which atomic and/or compound functions are combined by binding at compatible connection and access points is defined in ETS 300 417-1-1 [13], clause 6.

5.2.3.3 Network functions included in specific equipment

The grouping of atomic and/or compound functions, drawn from the libraries of these functions contained within the present document, is restricted only by the combination rules given in ETS 300 417-1-1 [13], clause 6. There is therefore no restriction on the functions which can be included in a specific equipment. Furthermore, it is possible to specify equipment which complies with the present document and which can be configured in a number of ways to carry out different network functions.

EXAMPLE: More than one adaptation function, of the same or of a different type, can be "present" in a NE and connected to a single termination function. For such a case, a subset of the adaptation functions may be "active" (providing service) while the others are "inactive". The signals applied to the "inactive" group of adaptation source functions are not forwarded to the termination source function. This configuration can be modified over time.

5.2.3.4 The functional model and the information model

The Functional Model of an equipment describes the way in which the equipment accepts, processes and forwards information contained in a signal. Thus, not only are the internal processes of the equipment specified but the internal and external interfaces are also specified. The functional model also specifies the performance criteria which shall be met by each process, and the actions which shall be taken when these performance criteria are not met. The performance of a process or interface is determined by the number and nature of the anomalies which occur within the process.

The Information Model describes an equipment from the management viewpoint as a collection of Managed Objects (MOs) which can be manipulated by a management system. These MOs are instances of the MO classes defined in ETS 300 469 [16] and ETS 300 304 [8]. These MOs, and their attributes, are expressed in a standard notation defined for this purpose (refer to ITU-T Recommendation X.721 [37]). The definition of each MO class is thus derived from a specific part of the functional model. It cannot be assumed that a one-to-one relationship exists between each function and each MO, neither should it be assumed that the functional model data is always displayed unchanged.

The relationship between functions in the functional model of an equipment, and the managed objects which represent them in the Information model is demonstrated by the following examples. Interconnections between functions formed by binding compatible connection points appear in the information model as a relationship between the corresponding MOs. As a second example, when a function declares a failure it appears in the information model as a notification, which informs the manager of the functional model event. The management system can select the notifications it wishes to receive, so it cannot be assumed that an event in the equipment is always notified to the management system.

The present document and ETS 300 469 [16] are, therefore, closely associated. It is intended that the definition of the attributes for a MO contained within the information model corresponds to the functional definition of the NE concerned.

5.2.4 Network layering principles

The ATM transport network can be described by a set of network layers. Figure 3 depicts the server/client relationships of the ATM layers and of some of the Physical Layers (SDH and PDH).

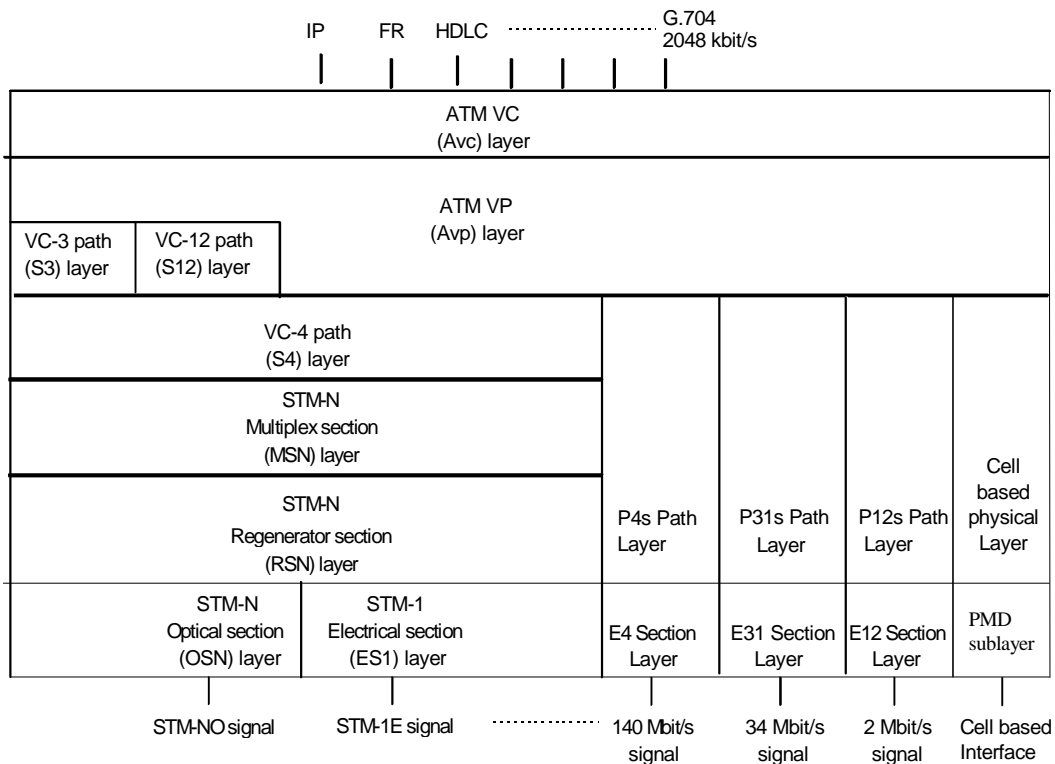

Figure 3: Examples of transmission layers and interface signals

NOTE 1: The AAL is not shown in Figure 3 as it is not strictly a layer in the sense of the EN 301 163-2-1 [17] modelling.

NOTE 2: Not shown in the Figure 3, but addressed in ETS 300 417-1-1 [13], is the Synchronization Distribution layer which describes the synchronization function for some ATM equipment. In addition, management, power supply and station alarm interfaces are also part of an equipment, but are outside the scope of the present document.

6 Connectivity capabilities

6.1 Introduction

In the following the different defined connection types are shortly summarized. ITU-T Recommendation I.150 [20] describes the rules for making connections from links and describes how unidirectional communication capability can be constructed from a bi-directional connection with asymmetric bandwidth. ITU-T Recommendation I.326 [22] discusses multipoint connections in ATM. For the multipoint connection types a figure is provided giving an example for the connectivity capability. The figures can show network wide connectivity irrespective of the Virtual Path (VP) or Virtual Channel (VC) layer, in which case the "circle" is a node. The figures can also show element wide connectivity irrespective of the VP or VC layer, in which case the "circle" is a connection matrix.

The defined connection types are:

- point-to-point connection (uni-directional);

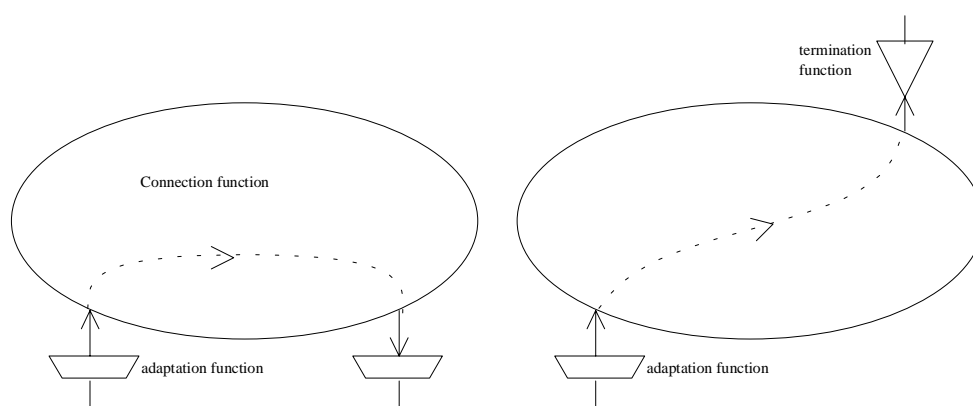

Figure 4: Two examples of unidirectional point-to-point connection

- point-to-point connection (bi-directional);

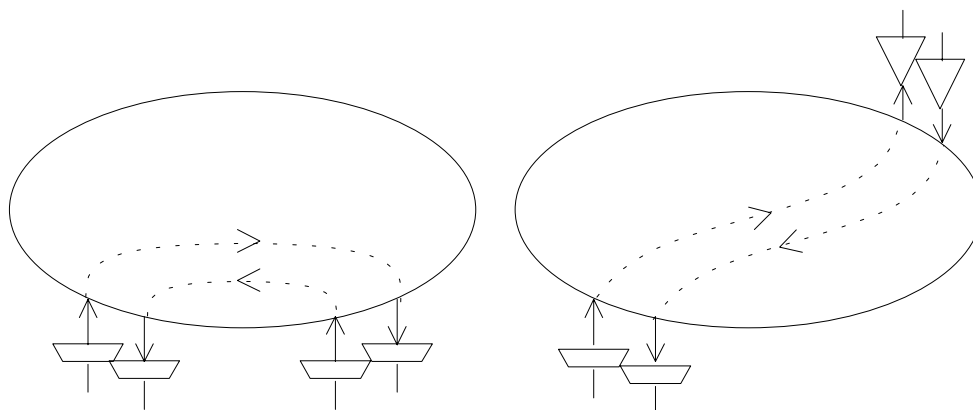

Figure 5: Two examples of bi-directional point-to-point connection

- point-to-multipoint connection (uni-directional).

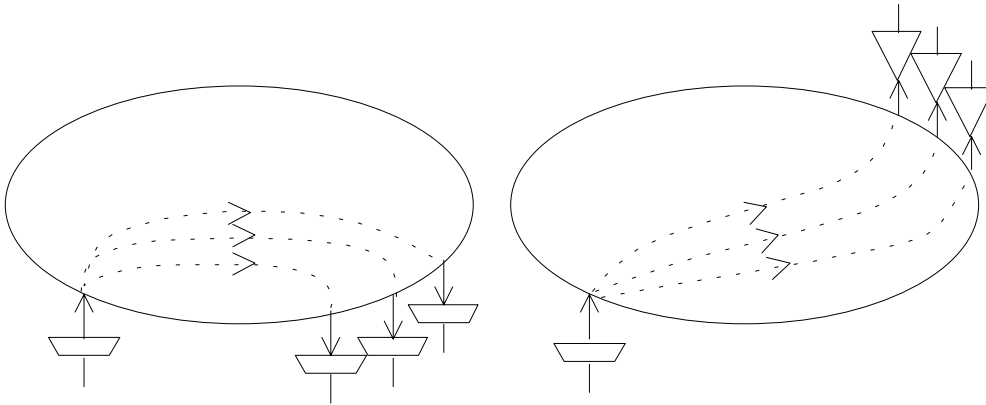

Figure 6: Two examples of uni-directional point-to-multipoint connection

- point-to-multipoint connection (bi-directional);

See also subclauses 6.4 and 6.5 in the present document on multipoint connections.

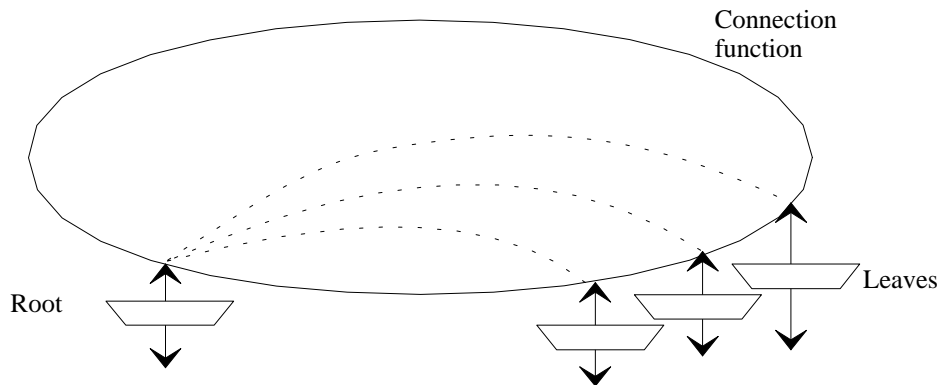

Figure 7: Example for bi-directional point-to-multipoint connection

- multipoint-to-point connection (uni-directional);

See also subclauses 6.4 and 6.5 in the present document on multipoint connections.

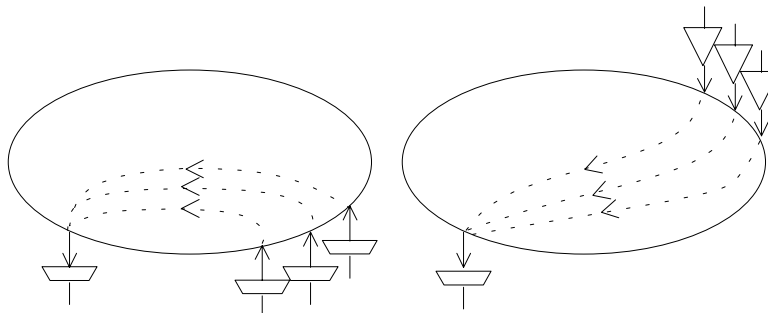

Figure 8: Two examples of uni-directional multipoint-to-point connection

- multipoint-to-multipoint connection (uni-directional);

See also subclauses 6.4 and 6.5 in the present document on multipoint connections.

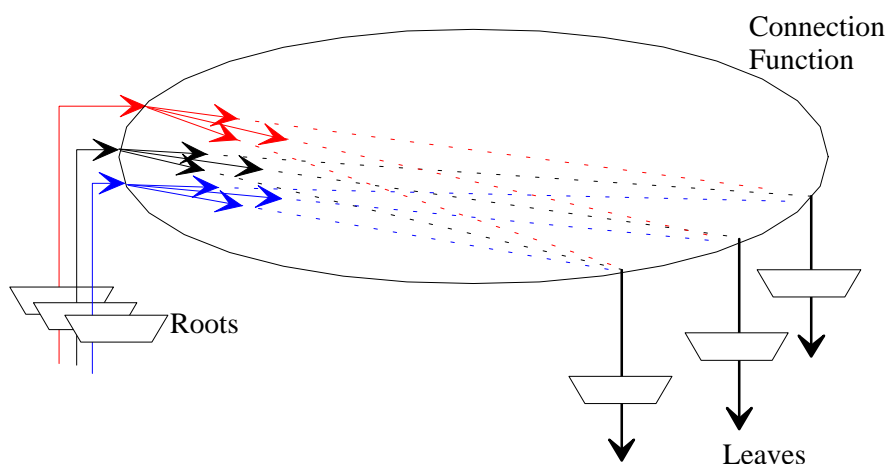

Figure 9: Example for uni-directional multipoint-to-multipoint connection

- multipoint-to-multipoint connection (bi-directional).

See also subclauses 6.4 and 6.5 in the present document on multipoint connections.

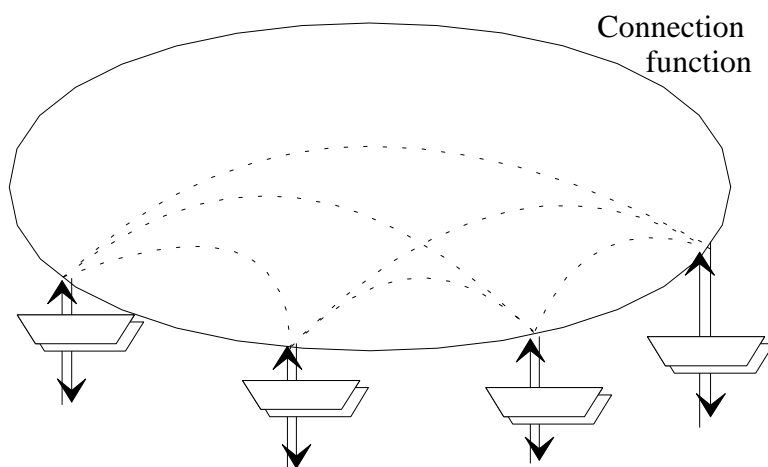

Figure 10: Example for bi-directional multipoint-to-multipoint connection

6.2 Number of connections supported

The number of connections that can be supported per port, per element (generalised switch/mux/concentrator) is for further study. The impact of the different connection types on the number of connections that can be supported is for further study.

6.3 Point-to-point connections

A description of bi-directional point to point connections is for further study.

The requirement for unidirectional point to point connections is for further study.

6.4 Point-to-multipoint connections

6.4.1 Overview

Point-to-multipoint connections interconnect multiple connection endpoints by using a tree topology as shown in Figure 6 and Figure 7. Thereby, one endpoint (called root node) sends cells which are copied at the tree's intermediate vertices and sent directly to all other endpoints (called leaf nodes). Each leaf node can send cells directly to the root node, but leaf nodes can not communicate directly among each other. Depending on the bandwidth allocated in root-to-leaf and in leaf-to-root direction, point-to-multipoint connections can be uni-directional or bi-directional. Bi-directional point-to-multipoint connections (also called composite connections according to ITU-T Recommendation I.326 [22]) can be symmetrical or asymmetrical. It may be necessary to send cell copies to each interface connected to the NE (full multipoint according to ITU-T Recommendation I.326 [22]).

6.4.2 Definitions

To support the defined multipoint connection types, two ATM layer connection functions, namely ATM cell multicast and ATM channel merging, are defined.

6.4.2.1 ATM cell multicast

ATM cell multicast implies copying of cells from one root and routing of the cell copies to multiple destinations, called leaves. Figure 11 shows the different options for ATM cell multicast, which are distinguished by the destinations of the cell copies.

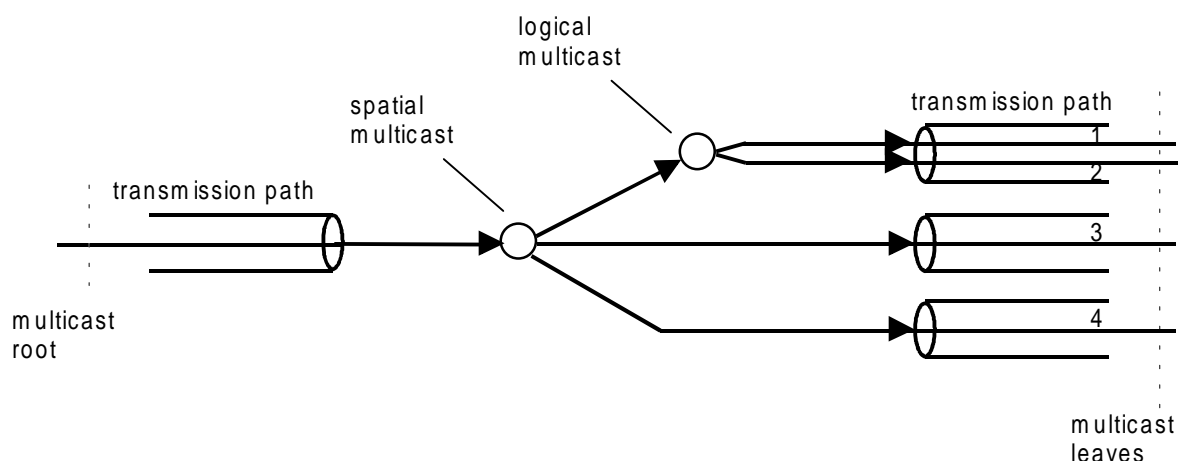

Figure 11: Example for Spatial and Logical Multicast for point-to-multipoint connections

6.4.2.2 Spatial multicast

If the destination of the cell copies are different transmission paths, the operation is called ATM spatial multicast. Within the switching network, cells are physically multiplied by sending them to several outputs. Since the ATM connection identifier (Virtual Path Identifier (VPI) or VPI/Virtual Channel Identifier (VCI) depending on the layer) used by the root may already be in use by another connection on the server layer, header translation may be required.

6.4.2.3 Logical multicast

If several leaves share the same Transmission Path (TP), e.g. several cell copies have to be sent over the same Virtual Container level 4 (VC-4), the operation is called ATM logical multicast. In this case, a cell is sent repeatedly to the same port with different VPI/VCI values. It is possible e.g. to put one Virtual Channel Connection (VCC) into several Virtual Path Connections (VPCs) with different VCI values.

6.5 Multipoint to point connections

There are two mechanisms by which multipoint to point connections can be constructed: by channel merging in the same layer or by keeping the channels separate and bringing them together at a higher layer. The channel merging technique is the concept that has been long established in ATM. However it will only work in a small selection of cases where the communications carry a source identifier within a higher layer or where the communications has no need to identify the source.

6.5.1 Merging is different from multiplexing

ATM VP multiplexing consists of mixing ATM cells of many VPCs into the same Transport Path but being able to distinguish them from each other thanks to their VPI values. The ATM VC multiplexing consists of mixing ATM cells of many VCCs into the same VPC, but being able to distinguish them from each other thanks to their VCI values.

The main fundamental characteristic of the ATM VP (respectively VC) merging is that all cells after being merged have the single VPI value of the root (respectively [VPI, VCI] values of the root).

It has the drawback to prevent identification of the source of the traffic at the ATM VP (respectively VC) level.

This rule makes the merging different from the multiplexing, where the information is clearly identified.

6.5.2 The Use of merging

6.5.2.1 Identification of the information at higher layer(s)

When using merging, the information is mixed up at a given layer, without any chance to de-multiplex it at this layer. However, it is possible to de-multiplex the information at higher layers.

If necessary, the de-multiplexing of the information merged at the ATM VP (respectively VC) level can be done at the VC layer (respectively AAL):

- When considering merging at the VP level, the de-multiplexing can be done by using the VCI values. It allows for distinguishing the different flows coming from different VP connections and which have been previously merged into one single ATM VP connection. The condition for that is that the VCI values of the different VPCs leaves have to be arranged to be different. If not, it will not be possible to distinguish two merged cells coming from two different VPC and with the same VCI. This condition must be checked when setting up the VCCs (e.g. by configuration).
- When considering merging at the VC level, some AALs provide for a multiplex identifier so that the far end can demultiplex the different streams. In AAL3/4, the MID field allows for distinguishing different flows coming from different VC connections and merged into one single ATM VC connection. However, one condition for this is to be able to rebuilt the AAL3/4 Protocol Data Unit (PDU) correctly when terminating the multipoint-to-point ATM connection. This aspect is treated in the subclause 6.5.3. The AAL 2 also provides an identifier for multiplexing/de-multiplexing different flows.

6.5.3 Merging scheme

A second aspect of channel merging is the way the information (the ATM cells) coming from several leaves is mixed up onto the root connection.

This aspect is called the "merging scheme". It has to be taken into account when:

- the upper layer makes use of a PDU which is too big to be projected into one single cell and;
- the upper layer needs to rebuild the messages for processing them (e.g. X.25 packets).

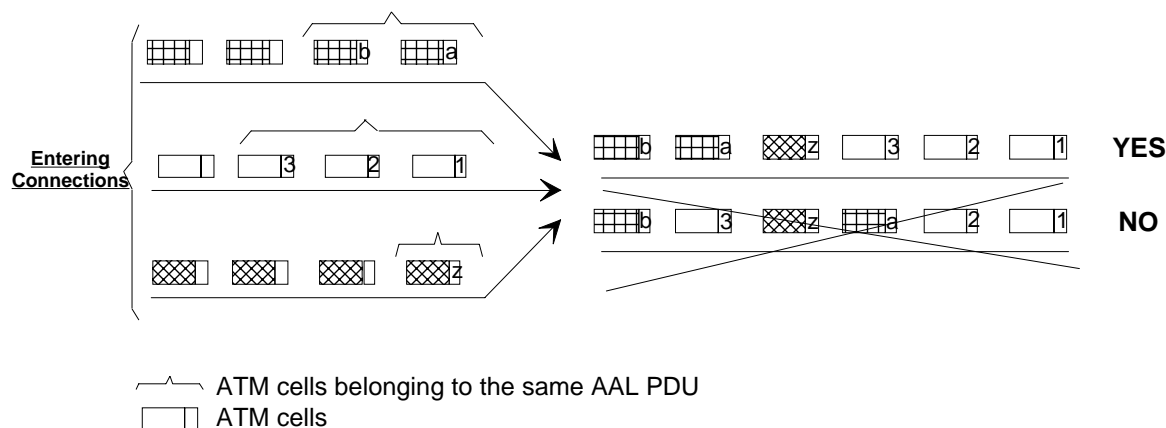

Figure 12: Example of a merging scheme where cell ordering needs to be respected

The condition for being able to **rebuild the messages**, is that they **must not be embedded nor overlapped**. For that purpose, an indication of the structure of the messages has to be known at the ATM level for allowing a correct merging scheme. For example:

- when using the AAL5, the Payload Type Indicator (PTI) field indicates the end of each message;
- for some applications, the RM cells are used to delineate each message.

In the two previous cases, the equipment can access the structure of the message at the ATM layer and merge the ATM cells on a "message basis", by avoiding mixing up cells belonging to different messages (see Figure 12).

If the messages are embedded or overlapped then a more complicated solution is required which either seeks to control the sources so that only a single message is in transit at anyone time or the message PDUs are reconstructed at a higher layer. The solution of controlling the sources is seen as impractical as it increases the delay, requires a complicated timing and token scheme, and is prone to hacking. The solution which consists of rebuilding the messages of the upper layer for allowing a good ATM merging scheme cannot be considered as a "purely" ATM solution, since the equipment would terminate the ATM connection, and process the upper layer PDU. These approaches also increase costs and delays.

Due to these limitations an alternative technique, defined in the following clause, was developed.

6.5.4 Bypassing merging

The alternative solution of merging at an equipment level consists of replacing a [N]multipoint-to-point unidirectional connection by N point-to-point unidirectional connections (See Figure 13). This solution is a network level solution.

In that case, each leaf is characterized by its ATM VPI or (VCI, VPI), and each leaf is connected to the root by a single unidirectional point-to-point connection.

This solution prevents from developing specific features in the equipment and allows for emulating merging very easily. The emulation of the merging takes place at the root with multiplexing in the middle of the network for the reverse direction. This division of labour is particularly important since it avoids having a "merge point" in the middle of the network. The interworking with higher layer protocols to reconstitute the "messages" from different users is handled at the root. The root is then able to forward or process the discrete "messages" from each distinct user. Hence all the root has to do is support having multiple "sockets" or occurrences on the same protocol stack, perhaps in the same way that a windows PC can run multiple copies of a word-processor. This is particularly important compared to a real merge point in the middle of the network where it must be of high efficiency and able to take into account the message structure of the higher layer protocols.

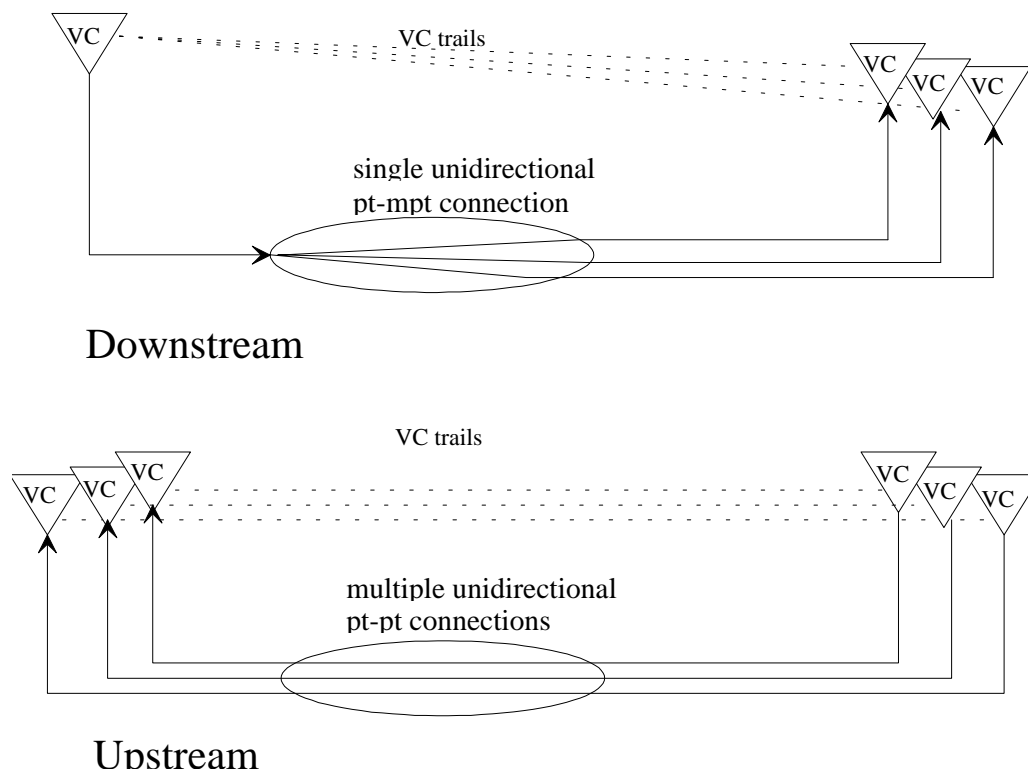

Figure 13: Combining simple connection types to form a bi-directional point-to-multipoint capability

6.6 Multipoint to multipoint connections

Multipoint-to-multipoint connections interconnect multiple connection endpoints such that cells originating at any endpoint are copied and sent to each remaining endpoint involved in the connection. I.e., if the multipoint-to-multipoint connection involves N endpoints, every endpoint involved in a multipoint-to-multipoint connection serves as a root in a tree for all of the remaining $N-1$ endpoints and at the same time as a leaf for the $N-1$ trees originating at the $N-1$ other endpoints (Figure 9 and Figure 10). Multipoint-to-multipoint connections can be symmetrical or asymmetrical.

6.7 OAM aspects of multipoint connections

The current OAM standards and recommendations do not allow for coping with merging connections. Therefore, the EN 301 163-2-1 [17] does not allow for coping with OAM aspects for ATM merged connections. For example, the receipt of multiple Receive Defect Indication (RDI) in response to a single downstream AIS has to be solved. That means that the development of services based on ATM merged connections today with an associated maintenance at the ATM level should make use of the merging-bypass solution.

6.8 Permanent virtual connections

Text describing the connectivity capabilities for PVCs will be provided in a later version of the present document.

6.8.1 Hard PVCs

Hard PVCs are the traditional Permanent Virtual connections.

6.8.2 Soft PVCs

This is a network level function. It is realized by signalling and management functions and is not a different connection type. Text describing the connectivity capabilities for soft PVCs in the present document is for further study.

6.9 Switched virtual connections

Text describing the connectivity capabilities of SVC connections are for further study.

Whether unidirectional SVC connections are allowed is for further study.

6.10 Support for different media upstream/downstream

For further study.

7 OAM functions

It is not recommended to provide simultaneously all OAM functions for all active connections e.g. PM may only be required for a percentage of active connections.

However, AIS and RDI functionality shall be provided for all active connections.

Continuity Check (CC) is suggested for all active connections (note that there are two options for CC functionality in ITU-T Recommendation I.610 [29]).

LB OAM cell capability shall be possible for an active connection

It is only necessary to provide N instances of PM capability that can be assigned to active connections. The value of N is dependent on the equipment and its usage, and is negotiable between the supplier and purchaser.

It should be noted that some fields of the OAM functions could be optional (e.g. the "Time Stamp" field in the fault management cells).

The OAM mechanisms have been designed for point-to-point and cross-connected connections. There is no clear restriction for the time being on the use of these mechanisms for switched connections. The use of OAM for switched connections is currently (1997) under study (in ETSI NA4). OAM for point-to-multipoint connections is currently (1997) under study (in ETSI NA4).

7.1 OAM naming conventions for ATM

The ITU-T Recommendation I.732 [31] keeps the transfer and layer management functions separate. It was agreed that the present document need not be so constrained if it improves the specification.

The OAM Functions make it possible to have an inband mechanism for:

- defect and failure detection;
- fault localization;
- defect information;
- performance monitoring;
- system Protection.

The OAM specification for ATM in the ITU (ITU-T Recommendation I.610 [29]) classifies OAM functions into 5 levels, called "Flows", which are numbered F1 to F5.

The OAM functions related to Flow 1-3 are defined in the appropriate physical layer (Here: The expression "layer" is used in the sense of ITU-T Recommendation I.321 [21]) specification e.g. ETS300 417 [12] (ITU equivalent is G.783) for SDH and PDH structured interfaces and ITU-T Recommendation I.432 [28] for cell-based interfaces. Note that the ATM terminology of F-n flows may not be used by those physical layers.

The OAM flow related to the ATM-layer (Here: The expression "layer" is used in the sense of ITU-T Recommendation I.321 [21]) is provided by the means of specific cells named "F4/F5 cells" whose structure is defined in ETS 300 404 [11] (ITU-T Recommendation I.610 [29]). The writing convention is that all flows are assumed to be End-to-End (e-to-e) unless specifically identified as Seg. flows.

7.2 OAM procedures

For further study.

This clause will provide an overview showing how the EN 301 163-2-1 [17] atomic functions can be connected together to form the OAM applications.

The following subclauses have been identified, other clauses for OAM applications will be added where necessary.

7.2.1 AIS application

For further study.

7.2.1.1 RDI application

For further study.

7.2.1.1.1 CC application

For further study.

7.2.1.1.1.1 LB application

For further study.

7.2.1.1.1.2 Performance Management application

For further study.

8 Traffic and congestion control functions

For further study.

NOTE: This clause needs to include Traffic descriptor, Usage Parameter Control (UPC)/Network Parameter Control (NPC), ATM transfer capability, Shaping, e-to-e Cell Delay Variation (CDV) objective, QoS classes.

9 Signalling

For further study.

10 Resource control functions

This clause aims at providing the modelling of the way in which an ATM resource request is handled in an equipment, but there are no requirements implied.

10.1 ATM resource requests to be processed by an ATM equipment

Two types of ATM resource requests can be considered from an equipment point of view:

- a request to establish or release a given VP or VC connection;
- a request for modifying the traffic characteristics of an already established VP or VC connection.

10.1.1 Establishing or releasing a VP or VC connection

Establishing a connection means to create a new point to point VPC or VCC or to add a leaf in a tree of multipoint connections with leaf initiated join.

Releasing a connection means to delete any VPC or VCC.

A request to establish or release a given VP or VC connection may be initiated independently by:

- **management protocol**, for establishing cross connected connections VPCs or VCCs. The equipment configuration management is controlled from either the Network equipment layer (e.g via the Q3-interface) or directly from the local craft terminal through the F-interface. The network equipment layer is controlled by the management layer. Request can be made to the management layer directly by the network operator or by customers or services communicating to the management layer via the service layer;
- **signalling protocol**, for establishing switched VCCs. The signalling messages are generally transported through a dedicated VCC. The protocols involved are DSS2, B-ISUP, Broadband Bearer Channel Control (BBCC) for VB5, Metasignalling, QSIG.

These ATM requests include (see Figure 14):

- some routing parameters;
- the traffic and QoS characteristics of the connection to be set.

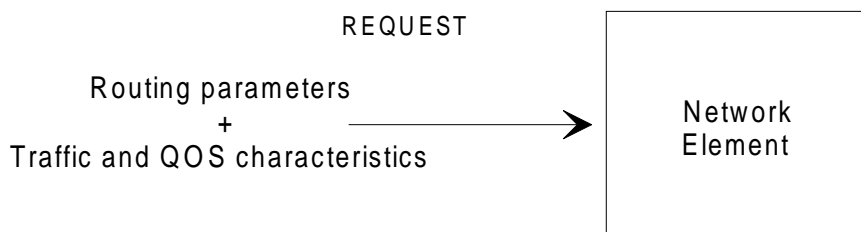

Figure 14: Establishing or releasing a VP/VC connection

The routing parameters can be for example an input interface identification and e.g. an E.164 destination address.

The traffic and QoS characteristics of the connection are respectively defined in ETS 300 301 [7] (ITU-T Recommendations I.371 [27] and I.356 [24]). These characteristics are summarized in Table 3.

Table 3: Traffic characteristics associated with a connection

General traffic characteristics	ATM Transport Capability (ATC)
	STD and CDV tolerances associated with each cell rate included in the given ATC
ABR & ABT additional specific characteristics	ATC tuning parameters for ABT and ABR connections (e.g. RIF, RDF,etc.)
Quality of Service (QoS) required	QoS parameters (CTD, CDV 2 points, Cell Loss Ratio (CLR ₀ , CLR ₀₊₁ , CLR ₁) (CLR))

Modification of the traffic characteristics of an established VP or VC connection

Modification of the traffic characteristics (see Table 3) of an already established connection may be initiated by:

- management protocol via an equipment management interface;
- signalling protocol;
- RM protocol.

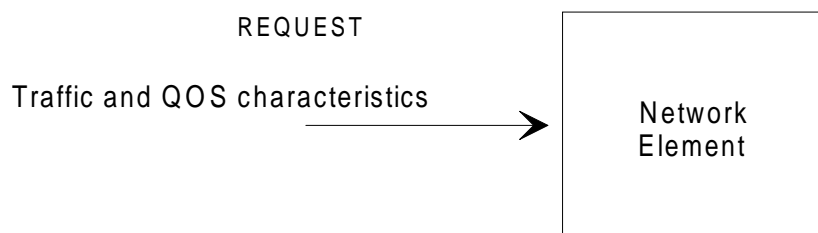

Figure 15: Modification of the traffic characteristics of an existing VP/VC connection

These ATM requests only include the new re-negotiated parameters for the existing connection. That means that this kind of request does not include any routing parameters.

10.2 General ATM equipment features for processing an ATM request

The processing of an ATM request by the equipment involves two main functions described in Figure 16.

10.2.1 Processing of modification request messages

The processing of the messages can be received by using different protocols (management, signalling or RM protocols). This processing is done by:

- the Management Applications for dealing with the Management Protocols;
- the Signalling Applications for dealing with the Signalling Protocols;
- the RM Applications for dealing with the RM protocols.

These functions allow for exchanging information following the protocol rules through the appropriate interface (Q3/F, User Network Interface (UNI)/Network Node Interface (NNI)). The applications are also strongly constrained by the specific time characteristics of the associated protocols (e.g. on the fly processing of RM cells in the case of ABR and ABT support). When an ATM request is identified, it is addressed to the CAC function for admission by the equipment. The timing scale to take into account the request originated by the Management, Signalling or RM protocols are very different.

10.2.2 CAC function

The equipment CAC function is part of the network level CAC function as defined in ETS 300 301 [7] (ITU-T Recommendation I.371 [27]), but at an equipment level. The CAC function takes as input the ATM request as defined in subclause 10.1, and accepts or rejects the request. An intermediate admission level (e.g. request "partially accepted") needs further studies.

NOTE: "Partially accepted" means for example that the request could be accepted with lower PCRs. Another example involves a request for setting up a point to multipoint connection with n leaves: the connection could be accepted for only p leaves ($p < n$).

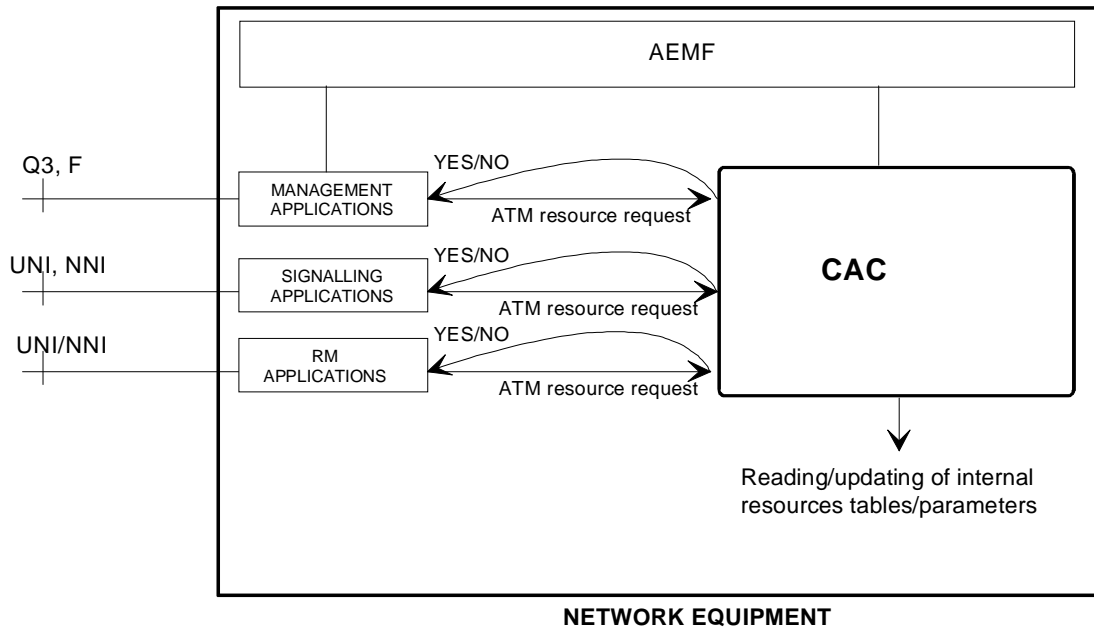

Figure 16: Functions involved for processing an ATM resource request

10.3 Management, signalling, RM applications

For further study.

10.4 CAC

The **CAC** function is can be considered as two processes named Service Admission Control (**SAC**) and Equipment Admission Control (**EAC**).

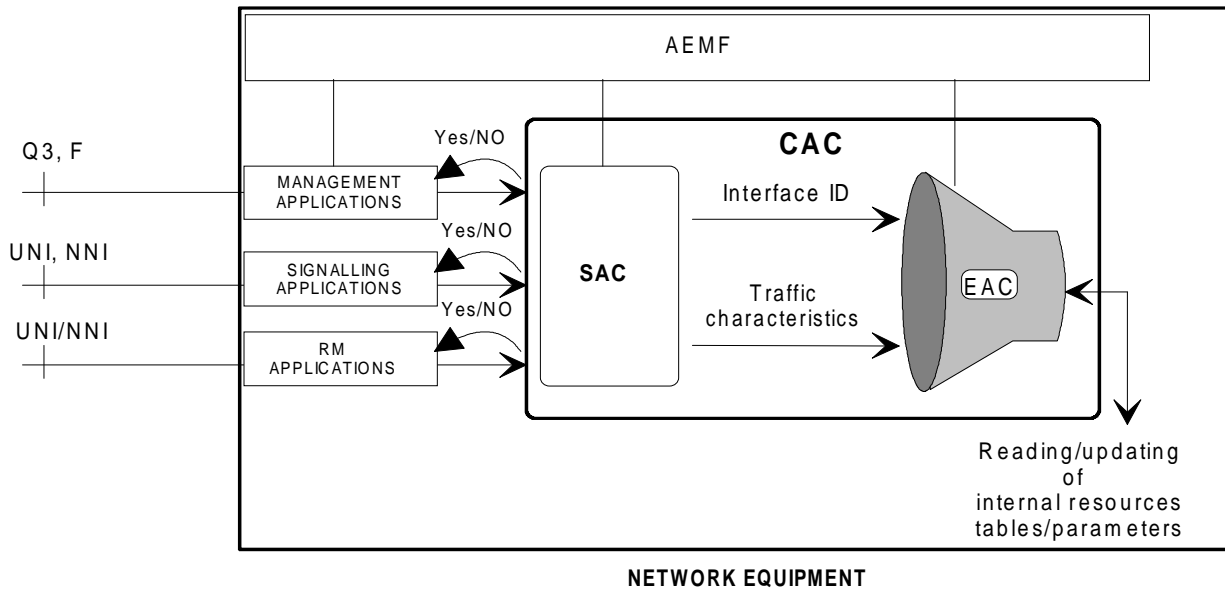

Figure 17: Architecture of the CAC

- The **SAC**: this step corresponds to the part of the admission which **does not need the knowledge of the real time availability of the resources of the equipment**. The SAC function is divided into two sub-functions: the Service Level ADmission (SLAD) and the routing function. The admission of a connection on a statistical basis is done by the SAC function. This function, or parts of this function, can be centralized, partially centralized, or distributed, depending on operator/vendor policy. That means that this function can or not be present within the equipment.
- The **EAC**. This step implies a more detailed process, which consists of **checking the current availability of the resources of the equipment**. This function can only be done at an equipment level, since the availability of the resources can change depending on the load of the equipment at a given moment. This function is implementation specific, considering that the load of the equipment depends on its implementation (e.g. presence of queues, blocking matrix), and works on a real time basis.

The YES/NO response between the CAC block and the different applications is the final response of the equipment to the ATM request. This final response results from the exchanges between the SAC and the EAC. These exchanges are illustrated in Figure 18.

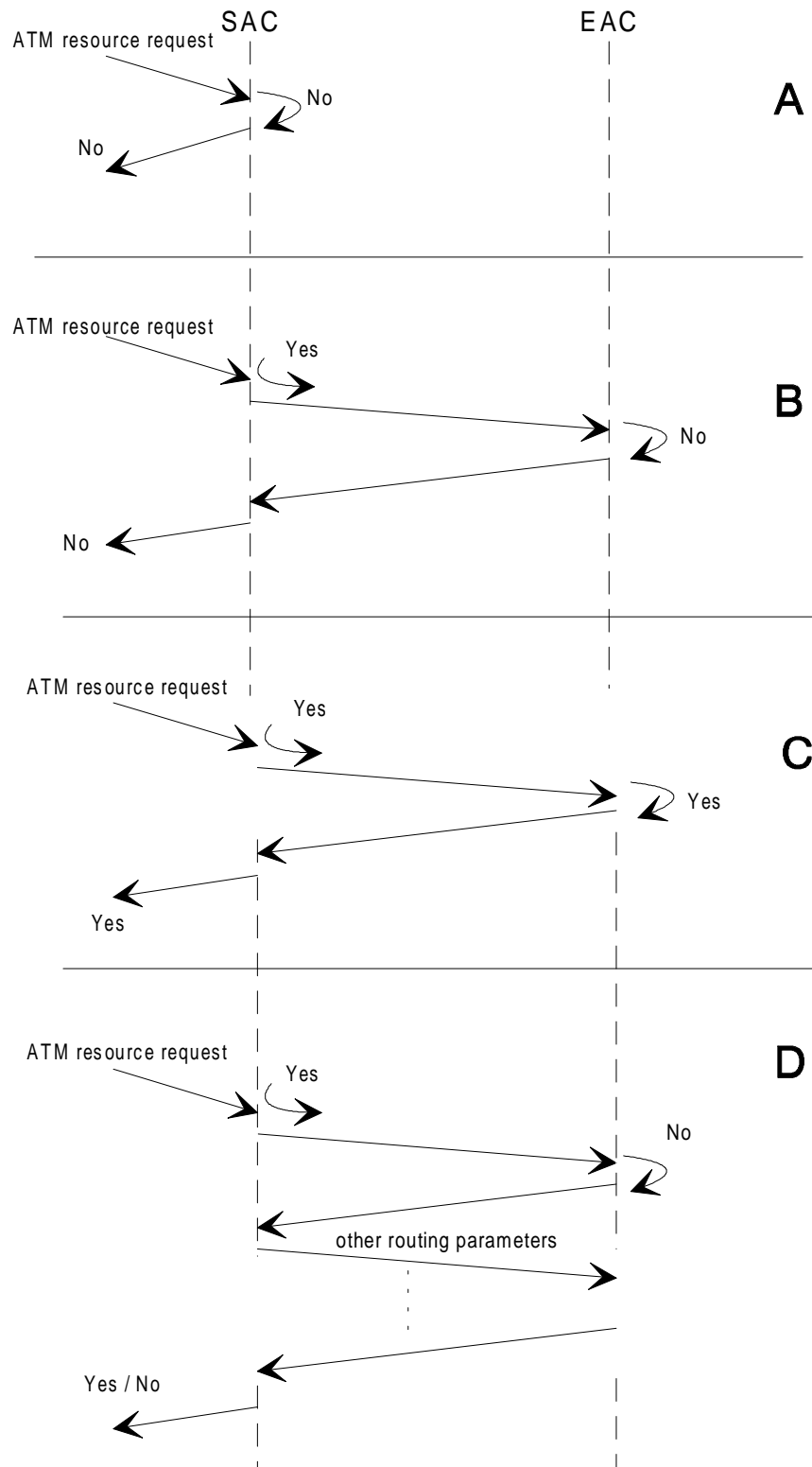

Figure 18: Examples for exchanges between SAC and EAC

10.4.1 SAC

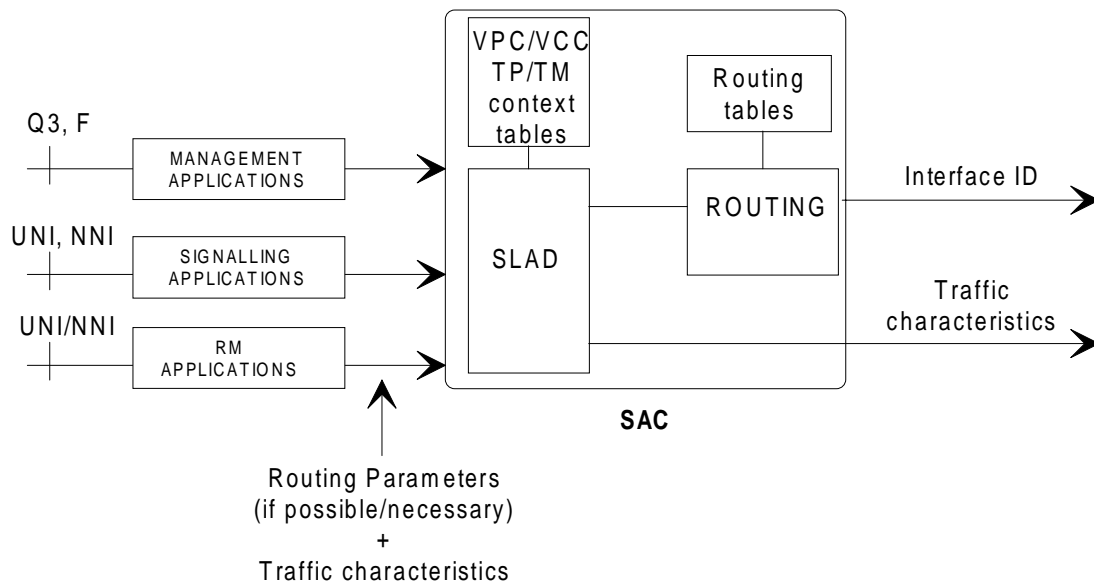

Figure 19: Service Admission Control

SAC includes two functions:

- the SLAD checks whether the request can be accepted or not by considering the VPC/VCC, TP and Transmission Media (TM) context tables. For example, rejecting a DBR VCC with a PCR larger than the PCR of the underlying DBR VPC does not imply any detailed equipment level verification, but only a theoretical checking of the traffic contract of the existing relevant VPC;
- the routing function is in charge of determining the appropriate interfaces for routing the connection. This function uses the information provided in the signalling or management messages (e.g. E.164 address, interface ID), and the routing tables. The routing function and/or the routing tables can be present, partially present, or not be present in the equipment, depending on operator/vendor policy. If several solutions (i.e. interface ID) are acceptable, the routing function then evaluates which is the best one.

10.4.1.1 SLAD

10.4.1.1.1 Description

The SLAD function receives the different requests coming with different formats (management, signalling, RM applications) and makes use of the VPC/VCC, TP and TM context tables to decide whether a request can be accepted or must be rejected, mainly on ATM ATM Transport Capability (ATC) and QOS class basis.

The VPC/VCC, TP and TM context tables contain the configuration parameters of the connections already set-up within the equipment. The configuration parameters are:

- the traffic characteristics of the connection (see Table 3);
- the OAM activated functions;
- the capacity of the TP and TM layers.

Other parameters are for further study. For example, these tables could also include:

- some lifetime parameters, for scheduling the use of some ATM connections at an equipment level (e.g. a VC connection could only be active between 1 a.m. and 7 a.m., and the associated bandwidth be available during the rest of the time for other connections);
- some statistical information, for allowing concentration. For example, consider the case of a bunch of DBR VCCs dedicated to VOD and carried by one single DBR VPC. The monitoring of the activity of the VCCs could show that only 80 % of the users are active at the same time in the worst case. This information could be stored as one parameter of the VPC.

For each new connection, the context tables are updated by the SLAD.

The SLAD process is for further study. This process makes use of the configuration parameters of the connections, but should also take into account the statistical parameters.

Considering the example of concentration provided above, two approaches could be considered for optimizing the use of the resources by overbooking:

- either the DBR VP is accepted by the SLAD with a PCR larger than the underlying TP capacity. The VPC will carry a bunch of VCCs which are not all active at the same time, and as such, will never overload the TP;
- or the underlying DBR VPC is chosen with a PCR equal to 80 % of the sum of the PCRs of all the VCCs. In that case, the SLAD should be able to accept a bunch of VCCs whose PCR sum is larger than the PCR of the VPC.

10.4.1.1.2 Configuration of the SLAD

The SLAD function may be configured via the management interfaces. The configuration of the SLAD involves all the layers: TM, TP, VP and VC.

One example of the SLAD TP configuration could be a selection of some criteria in accordance with a number of general parameters, depending on network applications, QoS requirements and customer traffic profile:

- declaration of the rate of the TP,
 - one or a combination of parameters such as:
 - connection type;
 - QoS classes;
 - ATC (DBR, ABR, etc.).
- partition size (see ITU-T Recommendation I.751 [16]).

A VP level configuration example is the activity rate of the VCCs carried within the VPCs.

10.4.1.2 Routing function

10.4.1.2.1 Definitions

The routing process can be centralized, partially centralized, or distributed, depending on operator/vendor policy. This function makes use of the routing tables. The routing tables can be centralized, partially centralized, or distributed, depending on operator/vendor policy. This clause deals with the routing at an equipment level.

When present within an equipment, the routing process allows for selecting the appropriate interfaces to connect. This function translates a network wide input information (e.g. IP or E.164 address) into an equipment level information (interface identification), by using the routing tables. This process generally leads to several appropriate solutions, since in many cases, different network routes can reach the same destination. In that case, the routing has to select the adequate solution, based on various criteria (e.g. network policy). These criteria need further study.

An interface identification includes all the levels involved in the connection (see Figure 20). For example, an interface for a VC connection is defined by a set of {TM Identifier, TP Identifier, VPI, VCI}.

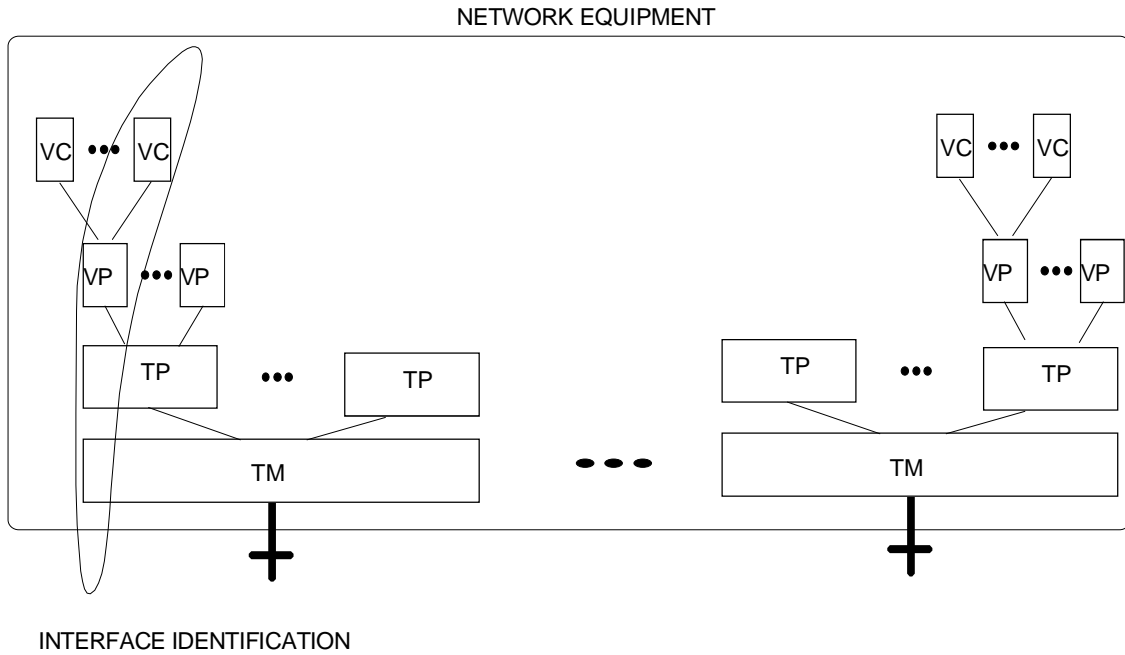

Figure 20: Interface to be considered for a VC connection

In the case of point to point connections (see Figure 21), the routing consists of determining zero, one or several couples of {input interface, output interface}, and to select the adequate one.

In the case of multiway N-to-P connection, the routing consists of determining zero, one or several sets of {N input interfaces, P output interfaces} and to select the adequate one.

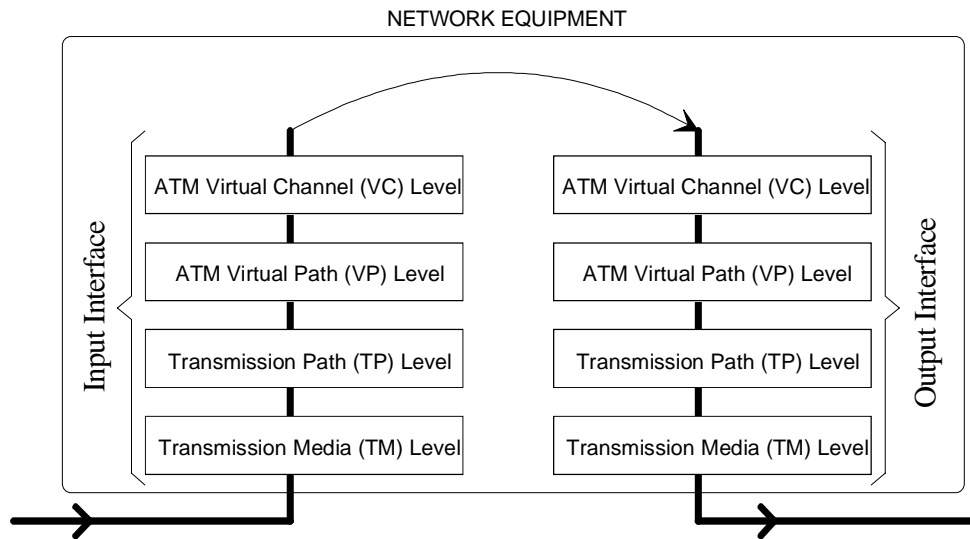

Figure 21: Selecting two interfaces in the case of a point-to-point connection

10.4.1.2.2 Input parameters of the routing process

The input parameters of the routing process can be:

- the input interface(s) and the address(/addresses) of the destination(s). In that case, the routing function has only to find out the appropriate output interface(s). For example, a point-to-point routing request can include the {TM Identifier, TP Identifier, VPI, VCI} for defining the input interface, and e.g. an E.164 address for defining a destination. The role of the routing function in that case is to provide the output interface identification corresponding to the given address;
- the addresses of the source(s) and of the destination(s). For example, a point-to-point routing request can include e.g. one E.164 address for the source, and e.g. an other E.164 address for defining the destination. In that case, the routing function provides the appropriate input and output interfaces.

10.4.1.2.3 Output parameters of the routing process

The output of the routing function for a point to point connection is a couple of interface identifiers.

The output of the routing function for an N-to-P multiway connection is a couple of {N input interface identifications, P output interface identifications}.

10.4.1.2.4 Configuration of the routing function

The configuration of the routing function via the management interfaces is for further study.

10.4.2 EAC function

10.4.2.1 Resource of an ATM equipment

The resources of an ATM equipment up to an ATM level (VP/VC) include:

- a set of VP and VC identifiers (VPI and VCI) to identify connections;
- bandwidth available on the TPs;
- buffer space evaluated in number of cells.

It is not said here where is located the buffer space. Indeed, an equipment may control internal resources which depend on the implementation. For example, an equipment built with a blocking matrix may control the allocation of switching capacity. This kind of internal resources can be considered as "buffer space". The buffer space can also be distributed within the equipment.

The way to manage the internal resources of an equipment depends on the implementation of the equipment and every manufacturer is free to choose how to allocate internal resources in order to satisfy the various requests in the adequate delays.

10.4.2.2 EAC process

The EAC algorithm used by the ATM NE is implementation specific.

Figure 22 shows the exchanges between the EAC function and the rest of the equipment.

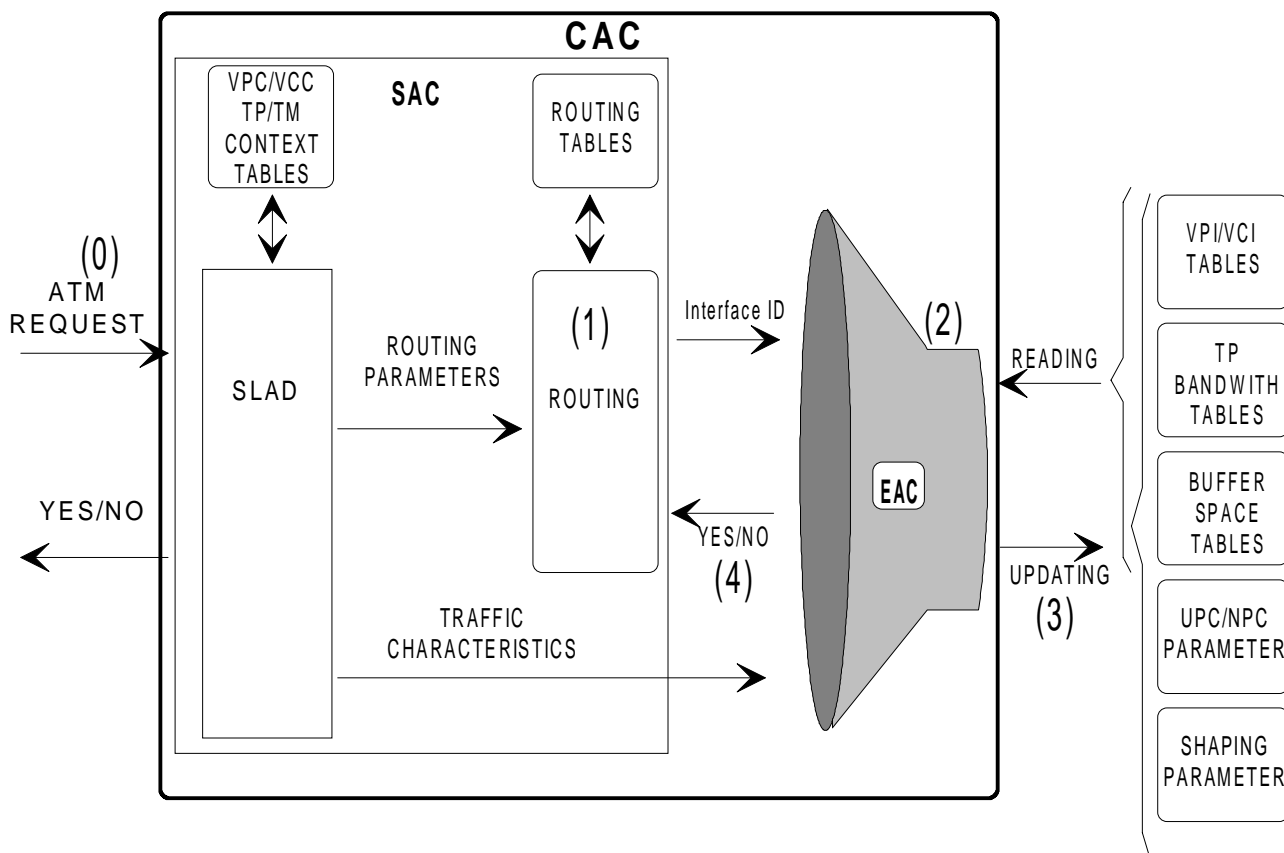

Figure 22: Processing of an ATM request

The EAC consists of accepting or rejecting a request characterized by an interface ID and traffic characteristics:

- the EAC function *derives* from the traffic characteristics defined in Table 3 of clause 10.1.1 the appropriate bandwidth and/or buffer space to be assigned to the connection to meet the negotiated QoS objectives; the derivation is implementation dependant;
- the EAC checks whether the solution could be accepted or not. This process involves the reading of the real time resource tables, considering the interface ID and the derived traffic constraints (VPI/VCI, TP bandwidth/buffer space);
- if the appropriate VPI/VCI, TP bandwidth and/or buffer space is not available, the EAC function rejects the solution;
- if the appropriate VPI/VCI, TP bandwidth and/or buffer space is available, the EAC function updates the NE resource tables (VPI/VCI, TP bandwidth/buffer space derived from negotiated or re-negotiated traffic and QoS parameters).

On connection release, the EAC updates VPI/VCI, bandwidth/buffer space allocation tables.

10.4.2.3 Configuration of the EAC function

The configuration of the EAC function via the management interfaces is for further study.

10.5 The processing steps of an ATM request

This clause shows the processing of an ATM request, based on Figure 22.

When an ATM request is received by the Management, Signalling or RM Applications, this request is firstly addressed to the SAC function (see step 0 on Figure 22).

The SLAD function checks whether the ATM request is acceptable following the VPC/VCC, TP and TM context tables. For example, the request could be not compliant with the ATC parameters.

The rest of the admission process, involving relations between the routing function and the EAC, depends on the nature of the ATM request:

10.5.1 Request to establish or release an ATM VP or VC connection

This involves 4 other steps (see numbers on Figure 22):

- 1) The routing function is in charge of determining the appropriate interfaces for routing the connection. This function uses the information provided in the signalling or management messages (e.g. address, interface ID, etc), and the routing tables. The routing function and/or the routing tables can be present, partially present, or not be present in the equipment, depending on operator/vendor policy. If several solutions (i.e. interface ID) are acceptable, the routing function then evaluates which is the best one. The selection of the best solution is based on various criteria (e.g. network policy): these criteria and the configuration of the routing function needs further studies.
- 2) The EAC function makes use of an interface ID and of traffic characteristics to determine whether a request can be accepted or not. The EAC derives the resources to be assigned to the connection according to an implementation dependant algorithm. Then, the EAC can reject or accept the solution depending on the resource tables: VPI/VCI, TP bandwidth, buffer space.
- 3) If the EAC accepts the connection, it then updates the different tables and parameters (VPC/VCI, TP bandwidth tables, buffer space tables, UPC/NPC parameters, shaping parameters).
- 4) If the EAC rejects the solution, then the routing function can propose an alternative interface ID, if available. In that case, the process loops to step 2.

10.5.2 Request to modify the traffic characteristics of an existing ATM VP or VC connection

The processing of such a request includes the second and third steps of the establishing/releasing request previously described. The main difference is that if the bandwidth is available, no routing is implied for this type of request, because the connection already exists. The EAC only accepts or rejects the request, depending on real-time resource availability. The fourth step in the case of a re-negotiation (when it is not possible to simply increase the bandwidth on the existing route) needs further study: one could envisage a new routing process to try to cope with the request when the current working interface is not able to support it, by trying to find another interface within the equipment, able to route the connection. This aspect is for further study.

The admission of the connection is then indicated to the Management/Signalling/RM Applications by the SLAD function.

10.6 Method for reducing outages on resource modification

For further study: There is a problem with a request for resource increase if the current TP cannot provide the extra capacity. Although the existing connection could be taken down and a new connection created in another TP, there will be a delay due to CAC process, equipment configuration time and at least one e-to-e cell propagation delay. These delays will be perceived as a break in service by the user. Even worse, there is a risk that the new connection request will fail and the connection falls back to the original connection on the original TP causing a longer outage.

It would be advantageous if a technique could be developed to establish an alternate path with the requested higher capacity, fill it with cells and then force the network to switch over. This sounds similar to the techniques used in 1 + 1 protection where there is a second path with identical traffic that can be switched to in the event of the working link failing.

The concept proposed is to create a "protection path" with higher bandwidth, wait until the protection path has filled with traffic then command a switchover to the "protection path". This would then be followed by a cessation of the original path so that just the new higher bandwidth path remains.

11 Traffic measurement functions

For further study: If it is necessary to set different performance objectives for different pieces of equipment.

For further study: If different classes of equipment may be required to only measure a subset of the parameters.

Traffic measurements is a main function required to get the necessary information (in short term and in the longer term) how traffic varies with time in the network. The results can be taken into account for network dimensioning (i.e. efficient usage of network resources, evaluation of capabilities for additional end customer connections, definition of routing tables), tariff structure definitions, and traffic contract supervision.

The dimensioning of an ATM network must guarantee an optimized usage of the provided network resources with a high quality of service for the end customers, and also a high availability of the network resources.

11.1 Traffic information collection

The definitions used for the traffic parameters in this clause can be found in ITU-T Recommendation I.751 [16].

11.1.1 TP usage measurement

The operations interface shall provide the OS with the ability to retrieve current counts (15-minute/24-hour) of the following information from the TP/VP_A.

- ingress cells (whole stream);
- ingress cells Cell Loss Priority (CLP)=0;
- ingress cells (OAM cells only);
- egress cells (whole stream);
- egress cells CLP=0;
- egress cells (OAM cells only).

Note that these measurements are for all cells excluding idle cells, corresponding to usage measurement in table 5-2 (A) and 5-2 (B) of ITU-T Recommendation I.732 [31]. These measurements are not the same as per VP measurements and should not be confused with them. These counts allow the OS to assess the network utilization in real-time and allow for capacity planning.

11.1.2 ATM cell level protocol performance information collection

Cell Level protocol monitoring involves collecting and thresholding information counts that measure an ATM NE's ability to successfully process and deliver incoming ATM cells. Cell Level protocol monitoring is particularly concerned with protocol abnormalities detected at the adaptation between the TP and the VP layers, and at the adaptation between the VP and the VC layers.

The operations interface shall provide to the OS the ability to retrieve current counts (15-minute/24-hour) of the following information from each ATM TP/VP_A:

Cells discarded due to Header Error Control (HEC) violations This parameter provides a count of the number of incoming ATM cells discarded due to an invalid header pattern.

Errored Cells This parameter provides a count of the number of cells which has an errored header pattern, independent if the error was corrected.

Discarded Cells due to Protocol Errors This parameter provides a count of the number of ATM cells misrouted due to an unrecognizable cell header field value.

11.1.3 VP/VC traffic load information collection

The operations interface shall provide mandatory to the OS the ability to retrieve current counts (15-minute/24-hour) of the following information for selected TP/VP_A and VP/VC_A. This corresponds to usage measurement in tables "5-3 (A)" and "5-3 (B)" of ITU-T Recommendation I.732 [31] and subclause 6.3.2.3 of ITU-T Recommendation I.751 [16].

- Ingress cells (whole stream);
- Egress cells (whole stream);
- Ingress cells (OAM cells only);
- Egress cells (OAM cells only).

These counts allow the OS to assess the network utilization in real-time and allow for capacity planning.

11.1.4 VP/VC UPC/NPC information collection

UPC and NPC algorithms are intended to enforce the traffic contract of the incoming cells to ensure that each access connection supported by the ATM NE is complying with prenegotiated traffic descriptors. Since cells discarded due to UPC/NPC functions and cells discarded due to transmission errors and malfunctions will have the same effect on the e-to-e performance of a VPC/VCC, it is important for trouble shooting and trouble sectionalization purposes to provide network managers with the tools needed to distinguish between these two events.

The following operations interface capabilities are required, so that management applications can retrieve ATM NE collected information that reflects the extent to which individual connections are violating their prenegotiated traffic descriptors.

The operations interface shall provide to the OS the ability to retrieve current counts (15-minute/24-hour) of the following information from selected VP/VC links for which UPC/NPC Disagreement Monitoring is being performed:

Discarded Cells due to UPC/NPC Disagreements (whole stream). This parameter provides a count of the number of ATM cells discarded due to traffic descriptor violations, detected by the combined CLP=0 and CLP=1 UPC/NPC policing function.

- **Discarded CLP=0 Cells due to UPC/NPC Disagreements (whole stream)**
This parameter provides a count of the number of high priority (CLP=0) ATM cells, discarded due to traffic descriptor violations detected by the CLP=0 UPC/NPC policing function. This counter is only required if CLP=0 traffic is separately policed.
- **Successfully Passed Cells (whole stream)**
This parameter provides a count of the number of cells that have been passed (i.e. not discarded) by the combined CLP=0 and CLP=1 UPC/NPC policing function.

- Successfully Passed CLP=0 Cells (whole stream)
This parameter provides a count of the number of high priority cells that have been passed (i.e. not discarded) by the CLP=0 UPC/NPC policing function. This counter is only required if CLP=0 traffic is separately policed.
- Tagged CLP=0 cells (whole stream)
This parameter provides a count of the cells which have been tagged.
- Discarded Cells due to UPC/NPC Disagreements (OAM cells only)
This parameter provides a count of the number of ATM cells discarded due to traffic descriptor violations detected by the combined CLP=0 and CLP=1 UPC/NPC policing function.
- Successfully Passed Cells (OAM cells only)
This parameter provides a count of the number of cells that have been passed (i.e. not discarded) by the combined CLP=0 and CLP=1 UPC/NPC policing function.

11.1.5 Call level information collection

With the support of Switched Virtual Connections (SVC) the dimensioning of an ATM network depends also on the behaviour of the end customers. Much more important are now the number of seizures by a single end customer, the duration of the SVCs and the flexibility of the destinations for a call.

For the determination of traffic and quality parameters for traffic management per access the number of call attempts, successful call attempts, and answered calls shall be counted. A call attempt is counted with receive of a Setup/Initial Address Message (IAM) (signalling) message per access and call direction. A successful call attempt is counted with sent a Setup/IAM message per access and call direction. An answered call is counted with sent the Answer message per access in backward direction and the Answer Acknowledge message in forward direction in the node. The measurement interval is 15 minutes. The measurement shall be administrable by the OS per UNI, Inter-NNI, and Intra-NNI access. The measurement data shall be collected for point-to-point and multicast calls.

For further study: how to associate a connection to a customer with SVCs for maintenance, SLAD checking and billing.

For further study: As SVCs are very short length it may be necessary to change the how and what is measured.

12 NE performance

This clause provides information on the following NE performance topics:

- Reference load for specifying the performance;
- Connection setup/clearing/denial performance (ITU-T Recommendation I.358 [26] call processing performance);
- Cell transfer delay and error performance objectives (by QoS classes) point-to-point/multipoint;
- ITU-T Recommendations I.356 [24] (ATM Layer Cell Transfer performance) and I.357 [25] (ATM cell layer availability).

12.1 ATM layer cell transfer performance

The ITU-T Recommendation I.731 [30] defines several types of ATM Network Equipment : cross-connects, switches, multiplexers and on-demand multiplexers. This clause will focus on NE performance parameters for cell transfer in the ATM layer; thus, we will address cross-connects and switches only; some modifications must be made in order to adapt NE equipment performance parameters definitions and their measurement conditions to the Interworking ATM Multiplexers.

The ITU-T specifies ATM transfer layer performance parameters objectives associated with QoS classes, whereas the ATM Forum defines ATM service categories which link up ATM transfer capabilities and QoS classes; so, before giving the NE performance objectives, it is useful to have a reminder of these different approaches, in order to know which performance objectives are applicable to which (ATC, QoS) combination or to which service category.

The Table 4 gives the correspondence between ATCs and QoS classes as defined by the ITU-T, and the service categories as defined by the ATM Forum. This table is just given as information. Shaded boxes give the (ATC, QoS class) combinations that are defined within the ITU-T (see ITU-T Recommendation I.356 [24]). There are no ITU-T equivalents of ATMF's VBR2-rt, VBR3-rt and UBR2 service categories.

Table 4: ITU-T ATCs and ATMF service categories

	Class 1 (stringent class)	Class 2 (tolerant class)	Class 3 (bi-level class)	U Unbounded class
DBR	CBR1			UBR1
SBR1	VBR1-rt	VBR1-nrt		
SBR2			VBR2-nrt	
SBR3			VBR3-nrt	
ABT/DT				
ABT/IT				
ABR			ABR	

ATM layer cell transfer performance of a NE can be evaluated using the following ATM cell transfer parameters defined both in ITU-T Recommendation I.356 [24] and ATMF TM v4.0:

- CER : Cell Error Ratio. However this is difficult to measure and therefore not realistic for in-service measurements
- CLR : Cell Loss Ratio (CLR_0, CLR_{0+1}, CLR_1)
- CMR : Cell Misinsertion Rate
- SECBR : Severely Errored Cell Block Ratio
- MCTD : Mean Cell Transfer Delay
- 2-point CDV : CDV between two MPs (generated by the NE)

The reference events for performance parameters measurement are defined in the ITU-T Recommendation I.353 [23].

Measurement methods of these parameters are described in the ITU-T Recommendations I.356 [24], and in the ATMF TM v4.0. The ability to measure these parameters and hence their usefulness depends on whether the measurements are being made "in-service" or "out-of-service" (see ITU-T Recommendation O.191 [35]). The application of these parameters to in-service and out-of-service testing is for further study.

NOTE: ITU-T Recommendation I.356 [24] is tightly related to ITU-T Recommendation I.357 [25] because performance parameters must be measured during availability periods only, which are defined in ITU-T Recommendation I.357 [25].

ATM NE performance objectives are QoS class dependent and are summarized in the Table 5 As these figures are for a single NE these are more stringent than those in ITU-T Recommendation I.356 [24] which are for a hypothetical reference connection stretching across 27 500km.

Table 5: QoS classes and the corresponding performance objectives

	CTD	2-pt. CDV	CLR₀₊₁	CLR₀	CER	CMR	SECB R
Class 1 (stringent class) DBR SBR1 ABT	(see note 1)	(see note 2)	5×10^{-10}	none	5×10^{-10}	1/day	10^{-8}
Class 2 (tolerant class) DBR SBR1 ABT	Un-defined	Un-defined	10^{-8}	none	5×10^{-10}	1/day	10^{-8}
Class 3 (bi-level class) SBR2 SBR3 ABR	Un-defined	Un-defined	Un-defined	10^{-7}	5×10^{-10}	1/day	10^{-8}
U class	Un-defined	Un-defined	Un-defined	Un-defined	Un-defined	Un-defined	Un-defined

NOTE 1: The delay experienced by a cell transported by a VPC/VCC with a load equal to 0 should not exceed $50 \mu\text{s}$ per multiplexing stage ; the number of multiplexing stages ranges from 1, for the most common NE, to 5 for big cross-connects. In addition, If we assume a 80 % load of the link under consideration and a M/D/1/k queue model (this case is similar to a $\Sigma D/D/1/k$ model when considering only one traffic source), then we must take into account an extra mean delay, due to the queue, equal to $2x\Delta$, where Δ is the cell transmission time at the interface link speed (the time interval that is necessary to transmit all the bits of one cell on the physical link under consideration).

The maximum CTD (10^{-9} quantile) to be replaced not exceed the:

$$\text{CTDmax}(10^{-9} \text{ quantile}) = T_{\text{mean}} + 6x\sigma$$

For a 80 % load, $T_{\text{mean}} = 2,4x\Delta$

and $\sigma = 5,8x\Delta$

Then $\text{CTDmax}(10^{-9} \text{ quantile}) = 37,2x\Delta$

For a 80 % load, $T_{\text{mean}} = 2,4x\Delta$

NOTE 2: The value of the maximum CDV generated by the ATM NE can be that given in ITU-T Recommendation I.371 [27]:

$$\frac{\tau_{\text{PCR}}}{\Delta} = \max\left[\frac{T_{\text{PCR}}}{\Delta}, \alpha\left(1 - \frac{\Delta}{T_{\text{PCR}}}\right)\right]$$

where:

T_{PCR} is the peak emission interval of the connection (expressed in seconds);

Δ is the cell transmission time at the output interface link speed; and

α is a dimensionless coefficient for the link load; the suggested value is $\alpha = 80 \%$.

This means that if two NEs (which are compliant with ITU-T Recommendation I.371 [27]), are cascaded, and if a shaped DBR traffic is introduced at the input of the first NE which generates a maximum CDV, then the traffic is still compliant with ITU-T Recommendation I.371 [27] at the input of the second NE.

The value of the input link speed is not relevant for the calculation of the CDV generated by the NE, except that it limits the bitrate of the connection.

12.2 Semi-permanent connection availability

The performance parameters for semi-permanent connection availability are defined in ITU-T Recommendation I.357 [25]; this recommendation is tightly related to ITU-T Recommendation I.356 [24], for it uses the definition of SESs in the ATM layer based on CLR and Severely Errored Cell Block Ratio (SECBR) cell transfer performance parameters.

The availability parameters are the Availability Ratio (AR) and the Mean Time Between Outages (MTBO). Two other related parameters may also be used : Unavailability Ratio ($UR=1-AR$) and Outage Intensity ($OI=1/MTBO$).

12.3 Call processing performance

This clause addresses call processing performance for switched VCCs in an ATM switch only; call processing performance for switched VCCs in an IAM (Initial Address Message) and for switched VPCs in any type of NE is for further study.

Call processing performance for switched VCCs are defined in ITU-T Recommendation I.358 [26] for a general B-ISDN network; in this clause, we give more details on how these definitions are to be adapted when addressing call processing performance in a single NE.

Table 6 summarizes the generic performance criteria for B-ISDN call processing functions as defined in ITU-T Recommendation I.358 [26]; some of these parameters are not relevant when considering a single NE. The objectives for call processing performance parameters can be expressed in term of mean and 95 percentile values and by giving worst case objectives taking into account peak traffic factors such as "busy hour". The adaptation of the ITU-T Recommendation I.358 [26] parameters for a single NE is for further study.

The most important parameters that are generally evaluated on ATM switches is the Connection Establishment Delay (CED) and the Call Setup Rate, although the latter is not mentioned in ITU-T Recommendation I.358 [26]. The Call Setup Rate is the maximum number of call setups that can be processed by the switch without any failure and is expressed in terms of Busy Hour Call Attempts (BHCA). The BHCA parameter is tightly dependent on the type of the NE : network core element, network edge element, network access element, Interworking ATM multiplexer, etc. A strict definition of BHCA is required from the signalling community, but it is approximately the number of call attempts per second successfully handled under busy hour conditions. It is not the role of the present document to make the definition.

Table 6: Call processing performance parameters (table 1/ITU-T Recommendation I.358 [26]-09/97)

Call Processing Function	Speed	Accuracy	Dependability
Connection Set-up	Connection Set-up delay Connection post selection delay Connection answer signal delay	Connection Set-up Error Probability	Connection Set-up Failure Probability
Party set-up	Party set-up delay Party Post Selection Delay Party answer signal delay	Party Setup Error Probability	Party Set-up Failure Probability
Connection Disengagement	Connection Release Delay Connection Disconnect Delay	Connection Premature disconnect probability	Connection clearing failure probability (CRFP)
Party Disengagement	Party Release Delay - Party Disconnect Delay	Party premature disconnect probability	Party clearing failure probability

13 Availability and reliability

13.1 Availability objectives

13.1.1 General

For a network provider, the reliability of NEs is of prime concern as it directly influences the availability of connections. The requirements for the availability of a B-ISDN semi-permanent connection are given in ITU-T Recommendation I.357 [25]. However, the availability of a connection depends not only on the reliability of the NEs themselves but also on the level of network redundancy. Furthermore, it depends on the restoration times of the equipment involved. The restoration times depend to a great extent on the Operation, Administration and Management (OAM) philosophy of the network provider.

A manufacturer has, in most cases, requirements from several operators to take into account. Requirements from a certain network provider will depend on the level of economic development of the country concerned, the degree of market competition, customer requirements, the level of network redundancy, the level of maintenance support, etc.

The basis for determining the availability of a NE should be the analytical method for dependability as described in ITU-T Recommendation E.862 [19].

The main point of the analytical method is that dependability aspects are taken into account as an economic factor. The level of availability is thus dimensioned according to cost-benefit analyses rather than by beforehand stated objectives.

The application of the method to network components is shown in the ITU-T handbook "Handbook on Quality of Service and Network Performance" [18].

13.1.2 Parameters

The lifetime of an item can be divided into periods where the item is in an "up state" and can perform its task and periods where the item is out of order ("down state"). The related statistical measures are "Mean Time To Failure" (MTTF) and "Mean Down Time" (MDT).

Down times are not necessarily caused by failures but also by planned maintenance actions.

The asymptotic availability (A) of the item is calculated as:

$$A = \text{MTTF}/(\text{MTTF} + \text{MDT}) \approx \text{MTBF}/(\text{MTBF} + \text{MDT}).$$

Mean Time Between Failure (MTBF) and MDT can either be calculated for a whole system or for parts or components of a system. From a network point of view, failures that result in degradation or failure of a system, or of parts and/or components of a system, are of interest, even if only redundant parts have failed which have no impact on the service supported by the system.

The dependability parameters are for further study. Table 7, , and show examples of parameters taken from ITU-T Recommendation G.911 [34].

Table 7: System service parameters

System service parameter	Units
Mean system availability	minium/year unavailability
Mean channel availability	minium/year unavailability per channel
Operation system interface availability	minium/year unavailability

Table 8: System component parameters

System service parameter	Units
System MTBF	years
Plug-in circuit packs MTBF	years
Frequency of scheduled maintenance actions	events per year
Random failure rate	events per year
Infant mortality factor	dimensionless

Table 9: Active optical device reliability parameters

Active optical device reliability parameter	Units
Median Life (ML)	years
Standard deviation (σ)	dimensionless
Wear-out failure rate at 10 years	FITs
Wear-out failure rate at 20 years	FITs
Wear-out activation energy (E)	eV
Random (steady-state) failure rate	FITs
Random failure activation energy (E)	eV

Management unavailability: is defined as the inability of the NE to communicate with the Operation System (OS); it corresponds to the unavailability of management functions or part of management functions and is expressed as a percentage of time.

Total unavailability: probability of a total inability for the equipment to maintain any traffic expressed as an MTBF value.

13.1.3 Derivation of MTBF values

Calculation of MTBF values based on Failure In Time (FIT) values should use the methodology described in ITU-T Recommendation G.911 [34].

13.2 Data integrity

Measures to ensure data integrity shall be taken in order to protect against data information losses, inaccuracies, and misproductions can be due to many factors, including:

- hardware failures;
- software malfunctions;
- procedural and documentation errors;
- maintenance and administrative activities;
- switch-overs between redundant equipment.

Redundant mass storage devices and processors, and backup mechanisms could be used to help conform to the data loss requirements. However, the techniques employed to achieve the required level of reliability is an implementation issue and, therefore, outside the scope of the present document.

Various types of information shall be stored in non-volatile memory to be protected against complete NE failures and e.g. loss of electrical power:

- run-time software;
- configuration data;
- log files from e.g. Fault Management (FM), Performance Management;
- usage measurement data;

- others.

On system start-up, the NE shall perform a diagnostic self test of hardware (e.g. mass storage) and software to ensure the integrity of the system. The self test shall not cause any degradation in traffic data.

13.3 Upgrade

In general, change in hardware or software versions, respectively. Hardware or software expansion of the equipment, should not degrade the performance and/or availability of any given connection through an equipment not affected by the hardware or software change.

Hardware upgrade

Upgrade of hardware may be required for system expansion, replacement of older hardware release etc. Any hardware change shall not disturb traffic or other information not involved in the upgrade process. It is typically a users requirement that replacement of single plug-in units must be done in-service.

Software upgrade

Upgrade of run-time software may be required for system expansion, introduction of new functionalities or correction of malfunctioning of present software. It is typically a users requirement that software upgrade must be done in-service. New software may be downloaded through the in-band or out-band DCN (Data Communication Network), and switch-over between the active software parts and the new software parts (i.e. activation) may be done on command. A switch-over should not affect traffic or impair data integrity.

Some users may require to have the possibility to revert to the software version active prior to the switch-over.

13.4 Start-up requirements

On initial system start, the NE shall be working according to an initial default configuration of the installed hardware and an initial MIB in the software system. If the newly installed equipment has previously been provisioned by an operator, the NE shall be initialized according to the provisioned configuration.

It shall be possible to initiate a restart of a complete running NE. After a restart, the state of the NE shall be the same as after initial system start.

After a power failure, the NE shall automatically start up to its normal operating state, which is working according to the configuration data in the MIB, without any interaction over external interfaces.

After power restoration, the operating state of the NE should be reached as soon as possible, ensuring to keep the connection unavailability of affected traffic as low as possible. A parameter for Mean Time To Restore should be investigated and is under study.

14 Protections switching on ATM layer

For further study.

15 AEMF

For further study.

15.1 Co-ordination between Layer Management functions

For further study.

15.2 Reports to the AEMF

For further study.

16 Timing

16.1 User plane related timing

Although the nature of ATM does not require any timing of the cell stream as such, there are several aspects in an ATM NE that require timing information:

- timing of the TP layers including the adaptation function to the TP function (TP/Avp_A_So/Sk);
- timing of the AAL function within Avc/XXX_A (where XXX is a client layer of Avc).

For network timing requirements, refer to ETS 300 462 [15] and its sub-parts.

The Timing requirements for the UPC/NPC functions are for further study.

16.1.1 Timing accuracy

In general, the timing accuracy of the clock information shall satisfy at least the requirements of the NE component that is the most sensitive to timing inaccuracy; i.e. if in an NE there are PDH interfaces without synchronous PDH or SDH interfaces, then the Equipment Timing Source shall in the minimum fulfil the requirements regarding accuracy, jitter and wander of this interface. If in an NE there are SDH interfaces or synchronous PDH interfaces of the hierarchy P31s or P4s, the Equipment Timing Source (Station Equipment Clock) shall in minimum fulfil all the requirements regarding accuracy, jitter and wander of this interface.

From the NE functionality point of view, it is not required to have more stringent requirements specified (e.g. Synchronization Supply Unit (SSU) quality). The transport network currently set up in the European Community has the timing sources such as Primary Reference Clock (PRC) or SSU to provide the necessary timing accuracy within the operators' transport and switching networks.

16.1.2 Equipment timing source

The Equipment Timing Source (ETS) is responsible for selecting the extracted timing information derived from the incoming traffic carrying signals or external timing inputs. It distributes the timing information with the NE to the functions and processes requiring timing information for e.g. timing the output of the traffic signals. The Equipment Timing Source functional blocks and their processes are described in ETS 300 417-6-1 [14].

16.1.3 Timing of the TP layers

The TP Layers are synchronized by the Equipment Timing Source. Timing information is also required for the cell rate adaptation into the Physical Path. Refer to the ETS 300 417-x-1 [12] (where x=2, 3, 4 and 5) for the timing requirements of the TP Layers and to EN 301 163-2-1 [17] for the requirements of the TP Adaptation function.

16.2 Management of plane related timing

A time-of-day reference shall be available in the NE for the purposes of e.g.

- time stamping events from the FM and Performance Management process;
- for Measurement purposes of VP/VC Usage Measurement of connections.

The reference source for the time-of-day clock shall be derived from a frequency reference having the precision, reliability and redundancy characteristics of the clock used to synchronize the TP signal e.g. from the Equipment Timing Source. The resolution shall be in steps of To Be Determined (TBD) milliseconds/seconds. The synchronization of time-stamps to absolute time (i.e. UTC) shall be to TBD seconds so that all stations can determine that a fault occurred at hh:mm:ss dd:mm:yy.

17 General characteristics

17.1 Management interfaces

The connection between the AEMF and the Network Element Management Layer shall be performed via the Q interfaces as described in ETS 300 150 [5], and ITU-T Recommendations Q.800 series.

The Access of the Local Operator Terminal to the AEMF shall be performed via the F-interface. The F-interface is not subject to standardization.

17.2 Power supply

The Interface for the power supply of the equipment shall comply to ETS 300 132-1 [3] for alternate current (AC) inputs, respectively ETS 300 132-2 [4] for direct current (dc) inputs.

17.3 Physical requirements

Requirements for the earthing and bonding of telecommunications equipment are given in ETS 300 253 [6].

17.4 Environmental requirements

The equipment shall comply with the requirements given in ETS 300 019-1-0 [1] and its sub-parts for the environmental conditions for operation, transportation and storage.

17.5 Electrical/Optical safety requirements

The equipment shall comply with the EMC requirements given in ETS 300 386-1 [9], ETS 300 386-2 [10]

Optical safety requirements are given with the requirements of the appropriate optical interface standards. In general, IEC 825-2 [38] requirements shall be met.

17.6 Equipment practice

The equipment shall conform to the specifications given in ETS 300 119 [2] and its sub-parts for mechanical design and layout, weight, heat dissipation etc.

18 Application requirements

For further study.

Annex A (informative): AIS application

NOTE: In the following text, an example for the AIS handling in a NE is given. Similar definitions will be provided e.g. for RDI and CC in future and be included together into the main body of the present document as normative text.

A.1 AIS application

AIS is generated to forward an indication that the normal traffic signal contains a defect condition and can not be forwarded. Initially, the AIS objective was to prevent consequential downstream failures being declared and alarms being raised ("Alarm Inhibit Signal"). Currently the AIS signal provides an "Alarm Indication Signal", which can be used to inhibit downstream failures/alarms and/or to report interruptions of service.

A.1.1 AIS definition

For SDH and PDH signals, AIS is an all-ONEs characteristic information (CI) or adapted information (AI) signal.

For ATM signals, AIS is a special OAM cell characteristic information signal: VP-AIS and VC-AIS cells. The insertion and detection of those cells is illustrated in figure A.1.

The VP-AIS signals are generated in the Specific Processes (SP) within the TP/Avp_A_Sk function. Figures A.1 and A.2 show one of the TP layers: the VC-4 layer, which is identified by "S4". VP-AIS signals are detected in the Avp_TT_Sk and Avpm_TT_Sk functions.

The VC-AIS signals are generated in the Specific Processes within the Avp/Avc_A_Sk function. VC-AIS signals are detected in the Avc_TT_Sk and Avcm_TT_Sk functions.

The mechanism for AIS detection within Seg. and at Seg. end points is for further study in NA4.

A.1.2 AIS flow

VP/VC-AIS insertion in the sink direction is controlled as follows: When an incoming defect or a TSF is detected at the TP/Avp_A_Sk function, VP-AIS is inserted on all affected VP connections. When an incoming defect or a TSF is detected at the Acp/Avc_A_Sk function, VC-AIS is inserted on all affected VC connections.

For SDH, the SDH AIS generation is illustrated in ETS 300 417-1-1 [13], subclause 7.6.

For ATM, figure A.1 illustrates this process as an example:

Due to a LOP defect (AU4dLOP) in the MS1/S4_A_Sk, the all-ONEs signal is inserted at the output. This signal is propagated through the VC-4 layer. The S4_TT_Sk "detects" (is informed of the presence of) this AIS signal by means of the activated incoming Server Signal Fail (SSF) signal. The S4_TT_Sk function forwards this AIS/SSF condition by means of an activated outgoing TSF signal. The S4/Avp_A_Sk is notified by the defect via the activated TSF signal and suppresses other triggered defects such as e.g. dLCD. As a consequence the Specific Processes of established VP connections in the S4/Avp_A_Sk insert the VP-AIS cells at their outputs.

The VP-AIS in the VP Characteristic Information is detected as a VP-AIS defect (VPdAIS) in the Avp_TT_Sk function. This function activates its TSF output signal, which is forwarded to the Avp/Avc_A_Sk function. The Specific Processes within those latter functions insert the VC-AIS cells at their outputs of established VC connections.

The VC-AIS in the VC Characteristic Information is detected as an VC-AIS defect (VCdAIS) in the Avc_TT_Sk function. This function activates its TSF output signal, which is input into the e.g. Avc/P12x_A_Sk function (2 Mbit/s Circuit Emulation). This latter function inserts the (2 Mbit/s) all-ONEs (AIS) signal at its output.

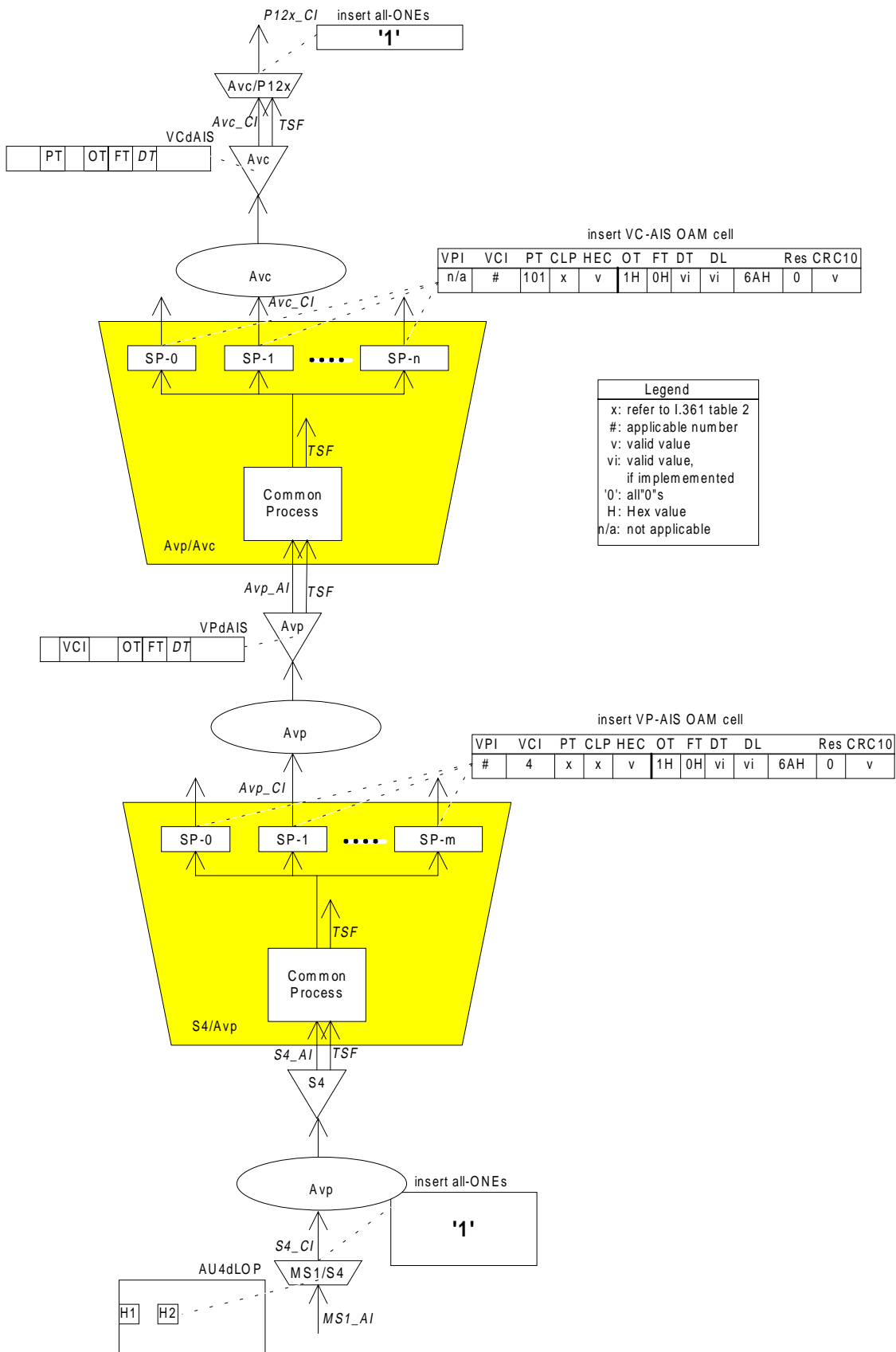

Figure A.1: Example for AIS insertion and propagation in the sink direction DL of ATM path layers

As soon as the direction through the layered structure reverts from the sink direction into the source direction, the VP-AIS signal gets multiplexed with other valid VP signals. In figure A.2, the VP signal in tributary slot number 26 (VPI=26) is connected via the VP connection function to tributary slot number 1 of the outgoing VC-4 signal. The VP-AIS cell stream in this VP signal is multiplexed with other VP signals into the payload of the VC-4. Then the VC-4 Path Overhead (POH) is added, followed by the AU4 pointer, and finally the STM-N SOH (not shown).

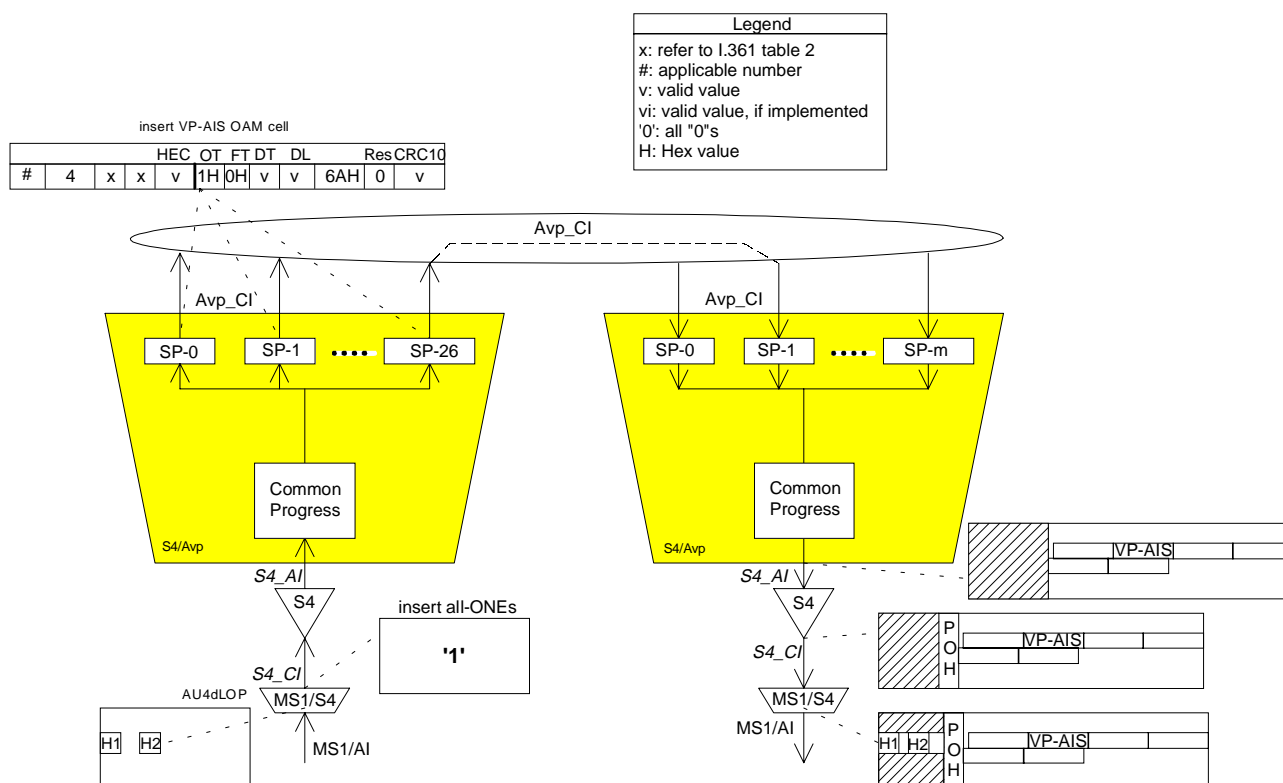
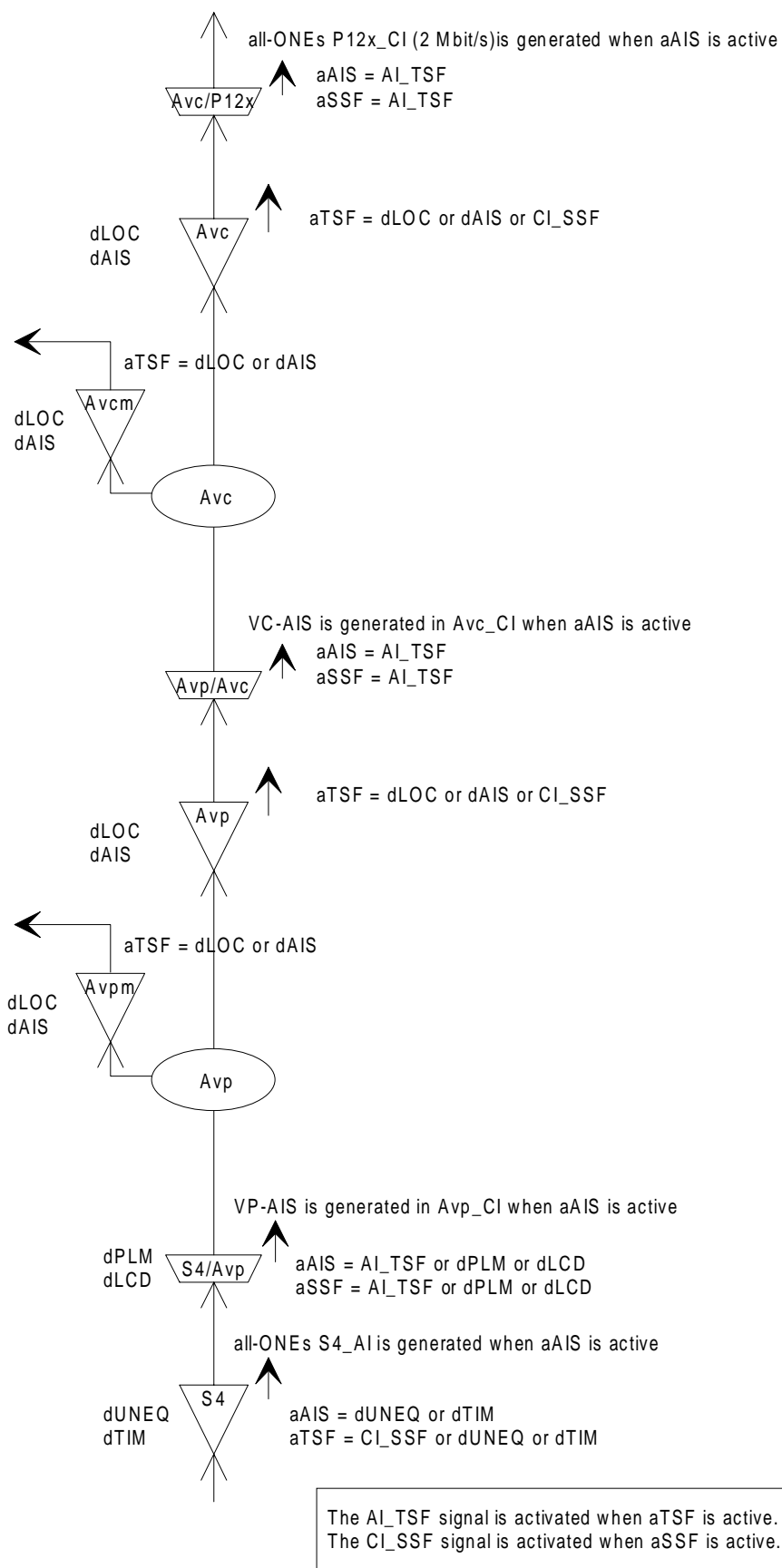

Figure A.2: Example of VP-AIS propagation through a connection function

A.1.3 AIS GENERATION CONTROL

Figure A.3 depicts the defects and consequent actions involved in AIS processing for the ATM VP and VC layers and the ATM Physical layer VC-4. The VC-4 signal is taken as an example; similar specifications exist for other physical layer signals (34 Mbit/s, 2 Mbit/s, etc). The behaviour for the physical layers of ATM is specified in ETS 300 417-x-1 [12].

AIS is inserted under control of the signal "aAIS" ("a": consequent Action). aAIS is determined within each atomic function, according the assigned boolean equation. E.g. for AIS insertion in the VC-4 termination sink function "aAIS = dUNEQ or dTIM".



NOTE: Only defects and consequent actions contributing to the propagation of AIS are shown. The VP/VC-AIS propagation for Seg. functions is for further study.

Figure A.3: Defect detection, SSF/TSF generation and AIS insertion in ATM path layers

The terms in the aAIS equation are defects (identified by the character "d") and incoming signal fail information (identified by "CI_SSF" and "AI_TSF"). CI_SSF is the signal that forwards the status of the consequent action aSSF, which is generated in the adaptation sink functions. Similarly, AI_TSF forwards the status of aTSF, generated in the termination sink functions. E.g. the defects that activate VC-AIS are thus: $aAIS = A_{vp_AI_TSF} = VPdLOC$ or $VPdAIS$ or CI_SSF .

VP-AIS is generated by the adaptation function from the physical layer ($S4_AI_TSF$ or $S4dPLM$ or $S4dLCD$).

Bibliography

The following material, though not specifically referenced in the body of the present document, gives supporting information.

- ETS 300 386-2-1: "Electromagnetic Compatibility (EMC) requirements; Part 2: Product specific compliance criteria and operating conditions; Sub-part 1".
- ETS 300 386-2-2: "Electromagnetic Compatibility (EMC) requirements; Part 2: Product specific compliance criteria and operating conditions; Sub-part 2: Transmission equipment".
- ETS 300 147: "Transmission and Multiplexing (TM); Synchronous Digital Hierarchy (SDH); Multiplexing structure".
- ETS 300 298-1: "Broadband Integrated Services Digital Network (B-ISDN); Asynchronous Transfer Mode (ATM); Basic characteristics and functional specification of ATM; Part 1: B-ISDN ATM functional characteristics".
- ETS 300 298-2: "Broadband Integrated Services Digital Network (B-ISDN); Asynchronous Transfer Mode (ATM); Basic characteristics and functional specification of ATM; Part 2: B-ISDN ATM layer specification".
- ETS 300 300: "Broadband Integrated Services Digital Network (B-ISDN); Synchronous Digital Hierarchy (SDH) based user network access; Physical layer interfaces for B-ISDN applications".
- ETS 300 337: "Transmission and Multiplexing (TM); Generic frame structures for the transport of various signals (including Asynchronous Transfer Mode (ATM) cells and Synchronous Digital Hierarchy (SDH) elements) at the ITU-T Recommendation G.702 hierarchical rates of 2 048 kbit/s, 34 368 kbit/s and 139 264 kbit/s".
- ETS 300 354: "Broadband Integrated Services Digital Network (B-ISDN); B-ISDN Protocol Reference Model (PRM)".
- ETS 300 417-4-1: "Transmission and Multiplexing (TM); Generic requirements of transport functionality of equipment; Part 4-1; Synchronous Digital Hierarchy (SDH) path layer functions".
- ETS 300 417-5-1: "Transmission and Multiplexing (TM); Generic requirements of transport functionality of equipment; Part 5-1; Plesiochronous Digital Hierarchy (PDH) path layer functions".
- ITU-T Recommendation I.363: "B-ISDN ATM adaptation layer (AAL) specification".
- ITU-T Recommendation Q.2931: "Broadband Integrated Services Digital Network (B-ISDN) - Digital subscriber signalling system No. 2 (DSS 2) - User-network interface (UNI) - Layer 3 specification for basic call/connection control.

History

Document history		
V1.1.1	May 1998	Public Enquiry PE 9841: 1998-05-20 to 1998-10-16