

Final draft **ETSI EN 301 126-3-2** V1.2.1 (2003-07)

European Standard (Telecommunications series)

**Fixed Radio Systems;
Conformance testing;
Part 3-2: Point-to-Multipoint antennas -
Definitions, general requirements and test procedures**



Reference

REN/TM-04150

Keywords

antenna, DFRS, DRRS, multipoint, testing,
transmission

ETSI

650 Route des Lucioles
F-06921 Sophia Antipolis Cedex - FRANCE

Tel.: +33 4 92 94 42 00 Fax: +33 4 93 65 47 16

Siret N° 348 623 562 00017 - NAF 742 C
Association à but non lucratif enregistrée à la
Sous-Préfecture de Grasse (06) N° 7803/88

Important notice

Individual copies of the present document can be downloaded from:

<http://www.etsi.org>

The present document may be made available in more than one electronic version or in print. In any case of existing or perceived difference in contents between such versions, the reference version is the Portable Document Format (PDF). In case of dispute, the reference shall be the printing on ETSI printers of the PDF version kept on a specific network drive within ETSI Secretariat.

Users of the present document should be aware that the document may be subject to revision or change of status. Information on the current status of this and other ETSI documents is available at

<http://portal.etsi.org/tb/status/status.asp>

If you find errors in the present document, send your comment to:

editor@etsi.org

Copyright Notification

No part may be reproduced except as authorized by written permission.
The copyright and the foregoing restriction extend to reproduction in all media.

© European Telecommunications Standards Institute 2003.
All rights reserved.

DECT™, **PLUGTESTS™** and **UMTS™** are Trade Marks of ETSI registered for the benefit of its Members.
TIPHON™ and the **TIPHON logo** are Trade Marks currently being registered by ETSI for the benefit of its Members.
3GPP™ is a Trade Mark of ETSI registered for the benefit of its Members and of the 3GPP Organizational Partners.

Contents

Intellectual Property Rights	5
Foreword.....	5
1 Scope	6
2 References	6
3 Definitions, symbols and abbreviations	7
3.1 Definitions	7
3.2 Symbols.....	9
3.3 Abbreviations	9
4 Requirements related to antennas conformance test	10
4.1 General requirements	10
4.2 Implementation under test (IUT).....	11
5 Supplier's Declaration	12
5.1 General characteristics	12
5.1.1 Frequency range.....	12
5.1.1.1 Frequency band	12
5.1.2 Class of antenna RPE.....	12
5.1.3 Sector angle	12
5.1.4 Gain	12
5.1.5 Environmental characteristics	12
5.1.6 Antenna stability	13
5.1.7 Antenna input connector	13
5.1.8 RL/VSWR.....	13
5.1.9 Inter-port isolation	13
5.1.10 Polarization	13
6 Test procedures for essential requirements	13
6.1 Radiation Pattern Envelope (RPE).....	13
6.2 Antenna gain	15
6.3 Other antenna characteristics.....	17
6.3.1 Passive intermodulation, VSWR and inter-port isolation	17
Annex A (normative): Supplier's Declaration	18
A.1 Supplier's Declaration against the essential parameters	18
A.2 Supplier's Declaration against the complementary/optional parameters	19
A.2.1 Environmental characteristics	19
A.2.1.1 Temperature range	19
A.2.1.2 Wind survival.....	19
A.2.2 Antenna stability	19
A.2.3 Antenna input connectors	20
A.2.4 RL/VSWR	20
A.2.5 Inter-port isolation	20
A.3 Supplementary information (if applicable)	20
Annex B (normative): Test report	21
B.1 Test results.....	21
B.1.1 Summary of tests	21
B.1.2 General information about the tests	21
B.1.3 Test result forms	21
B.1.3.1 Radiation Pattern Envelope (RPE).....	21
B.1.3.1.1 Azimuth co-polar radiation patterns.....	21
B.1.3.1.2 Azimuth cross-polar radiation patterns	22

B.1.3.1.3	Elevation co-polar radiation patterns	23
B.1.3.1.4	Elevation cross-polar radiation patterns	24
B.1.3.2	Antenna gain	25
B.1.3.3	Environmental conditions during the test	25
B.1.4	Measurement accuracy	26
B.1.4.1	Gain measurement accuracy	26
B.1.4.2	Co-polar and cross-polar radiation patterns measurement accuracy	26
Annex C (informative): Test site description		27
C.1	Test equipment used for tests	28
C.2	Supplementary information (if applicable)	28
Annex D (informative): Bibliography		29
History		30

Intellectual Property Rights

IPRs essential or potentially essential to the present document may have been declared to ETSI. The information pertaining to these essential IPRs, if any, is publicly available for **ETSI members and non-members**, and can be found in ETSI SR 000 314: "*Intellectual Property Rights (IPRs); Essential, or potentially Essential, IPRs notified to ETSI in respect of ETSI standards*", which is available from the ETSI Secretariat. Latest updates are available on the ETSI Web server (<http://webapp.etsi.org/IPR/home.asp>).

Pursuant to the ETSI IPR Policy, no investigation, including IPR searches, has been carried out by ETSI. No guarantee can be given as to the existence of other IPRs not referenced in ETSI SR 000 314 (or the updates on the ETSI Web server) which are, or may be, or may become, essential to the present document.

Foreword

This European Standard (Telecommunications series) has been produced by ETSI Technical Committee Transmission and Multiplexing (TM), and is now submitted for the ETSI standards One-step Approval Procedure.

The present document defines the type approval testing requirements for the antenna specific parameters, required directly by the relevant radio relay or antenna standard. Harmonized test methods and test report format, for these parameters, are also contained, herein.

In addition to the main body of the present document there are two annexes, namely the Supplier's Declaration (annex A) and the Test Report (annex B). The parameters in the two annexes are according to the main body of the present document.

The present document is part 3-2 of a multi-part deliverable covering the Fixed Radio System; Conformance testing, as identified below:

Part 1: "Point-to-point equipment - Definitions, general requirements and test procedures";

Part 2-1: "Point-to-Multipoint equipment; Definitions and general requirements";

Part 2-2: "Point-to-Multipoint equipment; Test procedures for FDMA systems";

Part 2-3: "Point-to-Multipoint equipment; Test procedures for TDMA systems";

Part 2-4: "Point-to-Multipoint equipment; Test procedures for FH-CDMA systems";

Part 2-5: "Point-to-Multipoint equipment; Test procedures for DS-CDMA systems";

Part 2-6: "Point-to-Multipoint equipment; Test procedures for Multi Carrier Time Division Multiple Access (MC-TDMA) systems";

Part 3-1: "Point-to-Point antennas; Definitions, general requirements and test procedures";

Part 3-2: "Point-to-Multipoint antennas - Definitions, general requirements and test procedures".

Proposed national transposition dates	
Date of latest announcement of this EN (doa):	3 months after ETSI publication
Date of latest publication of new National Standard or endorsement of this EN (dop/e):	6 months after doa
Date of withdrawal of any conflicting National Standard (dow):	6 months after doa

1 Scope

The present document details standardized procedures for conformance testing of antennas for Point-to-MultiPoint radio relay systems [1], [2] and [3] in order to achieve the approval by the Type Approval Authority.

The procedure for dealing with established products is outside the scope of the present document.

Standardized procedures are required in order to fulfil CEPT/ERC/DEC/(97)10 [4] on the mutual recognition, within CEPT, of conformance test of antennas carried out in individual CEPT Countries.

The present document is intended to be applied in conjunction with the individual antenna standards and will enable commonality in the presentation of test results, irrespective of the Suppliers/accredited laboratory carrying out the test.

NOTE: The recent draft Directive by the EEC [97-149 (COD)] and parallel work within CEPT ERC on mutual recognition, proposes that type approval against essential requirements can be carried out at manufacturers' or third party premises. The level of accreditation required needs to be clarified by CEPT.

The conformance tests described in the present document are related to antenna specific parameters required directly by the relevant antenna standards [1], [2] and [3].

The present document applies to both those antennas that are separate and those that are in some manner partially or fully integrated with the outdoor equipment. In all cases, whilst facilitating access to the appropriate antenna port, testing shall preserve the electro-magnetic environment i.e. be representative of the outdoor unit enclosure / electronics used in the typical (manufacturers' recommended) configuration. This need to maintain consistency with the manufacturer's recommended configuration is particularly important for less directional antennas (commonly with less than 25 dBi gain, although this value will depend on the specific ETS/EN parameters for that class, type etc).

It is noted that antennas intended for Point-to-Point (P-P) use are similarly the subjects of separate standards covering their characteristics and conformance testing [5], [6] and [7]. In some cases, particularly for the higher gains and frequencies, such P-P antennas may be appropriate for P-MP usage at the discretion of the regulatory authority. In such cases the regulatory authority will also define the applicable antenna and conformance-testing standard.

2 References

The following documents contain provisions which, through reference in this text, constitute provisions of the present document.

- References are either specific (identified by date of publication and/or edition number or version number) or non-specific.
- For a specific reference, subsequent revisions do not apply.
- For a non-specific reference, the latest version applies.

Referenced documents which are not found to be publicly available in the expected location might be found at <http://docbox.etsi.org/Reference>.

- [1] ETSI EN 301 525: "Fixed Radio Systems; Point-to-Multipoint Antennas; Antennas for Point-to-Multipoint fixed radio systems in the 1 GHz to 3 GHz band".
- [2] ETSI EN 302 085: "Fixed Radio Systems; Point-to-Multipoint Antennas; Antennas for point-to-multipoint fixed radio systems in the 3 GHz to 11 GHz band".
- [3] ETSI EN 301 215 (series): "Fixed Radio Systems; Point to Multipoint Antennas; Antennas for point-to-multipoint fixed radio systems in the 11 GHz to 60 GHz band".
- [4] CEPT/ERC/DEC/(97)10: "ERC Decision of 30 June 1997 on the mutual recognition of conformity assessment procedures including marking of radio equipment and radio terminal equipment".
- [5] ETSI EN 300 631 : "Fixed Radio Systems; Point-to-Point Antennas; Antennas for point-to-point fixed radio systems in the 1 GHz to 3 GHz band".

- [6] ETSI EN 300 833: "Fixed Radio Systems; Point-to-point antennas; Antennas for point-to-point fixed radio systems operating in the frequency band 3 GHz to 60 GHz".
- [7] ETSI EN 301 126-3-1: "Fixed Radio Systems; Conformance testing; Part 3-1: Point-to-Point antennas; Definitions, general requirements and test procedures".
- [8] ISO/IEC Guide 25: "Accreditation of Information Technology and Telecommunications testing laboratories for software and protocol testing services".
- [9] ISO/IEC Guide 28: "General rules for a model third-party certification system for products".
- [10] EN 45001: "General criteria for the operation of testing laboratories".
- [11] EN 45002: "General criteria for the assessment of testing laboratories".
- [12] ISO 9001 (1994): "Quality systems - Model for quality assurance in design, development, production, installation and servicing".
- [13] IEC 60835-2-2 (1994): "Methods of measurement for equipment used in digital microwave radio transmission systems - Part 2: Measurements on radio-relay systems - Section 2: Antenna".
- [14] ISO/IEC 15485 (1997): "Information technology -- Data interchange on 120 mm optical disk cartridges using phase change PD format -- Capacity: 650 Mbytes per cartridge".
- [15] IEC 60169 (series): "Radio-frequency connectors".
- [16] Council Directive 91/263/EEC of 29 April 1991 on the approximation of the laws of the Member States concerning telecommunications terminal equipment, including the mutual recognition of their conformity.
- [17] Directive 98/13/EC of the European Parliament and of the Council of 12 February 1998 relating to telecommunications terminal equipment and satellite earth station equipment, including the mutual recognition of their conformity.

3 Definitions, symbols and abbreviations

3.1 Definitions

For the purposes of the present document, the following terms and definitions apply:

accreditation: formal recognition that a testing laboratory is competent to carry out specific tests or specific types of test

accreditation body: body that conducts and administers a laboratory accreditation system and grants accreditation

accreditation system: system that has its own rules of procedure and management for carrying out laboratory accreditation

accredited laboratory: testing laboratory which accreditation has been granted in accordance with the ISO guide 25 [8] and ISO guide 28 [9] or EN 45001 [10] and EN 45002 [11]

antennas: that part of the transmitting or receiving system that is designed to radiate and/or receive electromagnetic waves

approval testing: approval testing is required for approval of the Implementation Under Test (IUT) by the appropriate authority for regulatory purposes. In this context approval implies that the IUT has met the essential requirements of the ETS/EN against which it has been tested.

axial ratio: the ratio of maximum to minimum power contained in the field components of the polarization ellipse

boresight: the axis of the main beam in a directional antenna

Central Station (CS): base station which communicates each way with many terminal stations and, in many cases, repeater stations

complementary requirements: in an ETS/EN all those requirements not part of the essential requirements are complementary requirements

conformance testing: the type testing process to verify to what extent the IUT conforms to the ETS/EN

co-polar pattern: diagram representing the radiation pattern of a test antenna when the reference antenna is similarly polarized, scaled in dBi or dB relative to the measured antenna gain

cross-polar pattern: diagram representing the radiation pattern of a test antenna when the reference antenna is orthogonally polarized, scaled in dBi, or dB relative to the measured antenna gain

essential requirements: basic set of parameters and functions which are necessary to meet any regulatory obligations imposed for radio frequency co-ordination

fixed beam: the radiation pattern in use is fixed relative to a defined mechanical reference plane

full conformance: the status of the IUT when it has successfully passed all the requirements of the conformance testing process and therefore meets all the mandatory requirements of the ETS/EN

gain: ratio of the radiation intensity in a given direction to the radiation intensity that would be obtained if the power accepted by the antenna were radiated isotropically

half power beamwidth: angle, relative to the main beam axis, between the two directions at which the measured co-polar pattern is 3 dB below the value on the main beam axis

input port(s): flange(s) or connector(s) through which access to the antenna is provided

inter-port isolation: ratio in dB of the power level applied to one port of a multi-port antenna to the power level received in any other port of the same antenna as a function of frequency

Implementation Under Test (IUT): representative sample of the equipment to be tested

isotropic radiator: hypothetical, lossless antenna having equal radiation intensity in all directions

Left hand (anticlockwise) polarised wave: an elliptically-or circularly-polarised wave, in which the electric field vector, observed in any fixed plane, normal to the direction of propagation, rotates in time in a left-hand or anticlockwise direction

main beam axis: direction for which the radiation intensity is a maximum

main beam: radiation lobe containing the direction of maximum radiation

mandatory requirements: a mandatory requirement is defined as one which the IUT (implementation under test) shall meet. To achieve full conformance all ETS/EN requirements are mandatory

mechanical tilt: fixed angular shift in elevation of the antenna main beam axis by a change to the physical mounting

optional requirements: the term "optional" is used in ETS/EN with two different meanings:

- Optional in the sense that the parameter or function itself is mandatory but there is more than one possible value or configuration which may be chosen (e.g. class of Antenna RPE, frequency band(s), etc.). Once an option is selected it becomes mandatory;
- Optional in the sense that the feature is not mandatory (e.g. antenna input connector etc.). However, once such an option has been implemented it becomes mandatory that it conforms to the requirements of the ETS/EN.

radiation pattern: envelope within which the radiation pattern shall fit

Radiation Pattern Envelope (RPE): envelope below which the RADIATION PATTERN shall fit

radiation pattern: diagram relating power flux density at a constant distance from the antenna to the direction relative to the notional antenna main beam axis. Specifically referenced in the present document to the zero degree reference direction.

radome: cover, of dielectric material, intended for protecting an antenna from the effects of its physical environment

repeater station: radio station providing the connection via the air to both the central station and the terminal station(s). The remote station may also provide the interfaces to the subscriber equipment, if applicable.

right hand (anticlockwise) polarised wave: an elliptically-or circularly-polarised wave, in which the electric field vector, observed in any fixed plane, normal to the direction of propagation, rotates in time in a right-hand or clockwise direction

sector angle: declared angle of coverage in azimuth of a sectored antenna

NOTE: Defined as 2α in the present document.

supplier: organization requesting the approval

Supplier's Declaration (SD): procedure by which a supplier gives written assurance that a parameter or function conforms to the ETS/EN

type approval authority: National Regulatory/Licensing Authority

type approval testing: type approval testing is the process of type testing for approval

NOTE: A type test is to be carried out successfully in order to achieve approval.

type testing: type testing is where a representative sample of the equipment is tested

NOTE: The test result is considered to be applicable and representative for all subsequent units of the same type. Any changes that could potentially affect the three essential requirements shall be notified to the Type Approval Authority.

Terminal Station (TS): remote (out) station which communicates with a central station

tilt: fixed, angular shift of the antenna main beam axis (boresight) in the elevation plane by either electrical, electronic or mechanical means

zero degree: declared direction as referenced to the antenna

reference direction: mechanical characteristics, used as reference for the RPE

integrated antenna: the antenna is considered to be integral to the product if either the antenna forms a component of the enclosure or the antenna is contained within the overall enclosure of the product

3.2 Symbols

For the purposes of the present document, the following symbols apply:

dB _i	decibels relative to an isotropic radiator
dB _{iC}	decibels relative to an isotropic circularly polarised source
dB _m	decibels relative to milli-Watt
dB	deciBel
2α	sector angle, (twice alpha)
GHz	GigaHertz
MHz	MegaHertz

3.3 Abbreviations

For the purposes of the present document, the following abbreviations apply:

CR	Complementary Requirement
CS	Central Station
ER	Essential Requirement
Ext	Extreme conditions
IUT	Implementation Under Test
OR	Optional Requirement

P-MP	Point-to-MultiPoint
P-P	Point-to-Point
Ref	Reference conditions
RL	Return Loss
RPE	Radiation Pattern Envelope
RS	Repeater Station
SD	Supplier's Declaration
TR	Test Required
TS	Terminal Station
VSWR	Voltage Standing Wave Ratio

4 Requirements related to antennas conformance test

P-MP antennas may be designed for Central Station (CS), Repeater Station (RS) or Terminal Station (TS) use, and may be categorized in the corresponding standard by means of type, class and range, as required [1], [2] and [3].

Some P-MP antennas require definition of the antenna zero degree reference, which is defined as the declared direction as referenced to the antenna mechanical characteristics, and this is used as reference for the RPE.

Although the RPE limits for TS and some RS antennas are generally identical for azimuth and elevation, the actual patterns should not be assumed to be symmetric.

4.1 General requirements

In table 1 the generic clauses and parameters are classified, for conformance test purposes, in terms of the various categories. The table also provides for defining the climatic conditions applicable during testing of the parameters.

Table 1: "Generic requirements" classification

Function or Parameter Description	Status for conformance			Requirement for conformance test			Power supply conditions		Climatic conditions for test		Limiting values	Test methods	
	ER	CR	OR	SD (see note 1)	TR	SD + TR	Ref	Ref + Ext	Ref (see note 2)	Ref + Ext		Clause Ref.	IEC 60835-2-2 [13] or other references. (see note 3)
Frequency range		X	X	X									
Frequency band(s)		X	X	X									
Class of antenna RPE		X	X	X									
Radiation Pattern Envelope (RPE)	X		X			X			X		X		IEC 60835-2-2 [13]
Sector or beam angle (see note 4) (2α)		X	X	X									
Number of beams (see note 5)		X		X									
Reference beam direction (ϵ) (see note 5)		X		X									
Antenna gain	X		X			X			X		X		IEC 60835-2-2 [13]
Environmental characteristics		X	X	X									
Antenna stability		X	X	X									

Function or Parameter Description	Status for conformance			Requirement for conformance test			Power supply conditions		Climatic conditions for test		Limiting values	Test methods	
	ER	CR	OR	SD (see note 1)	TR	SD + TR	Ref	Ref + Ext	Ref (see note 2)	Ref + Ext		Clause Ref.	IEC 60835-2-2 [13] or other references. (see note 3)
Antenna input connectors		X	X	X									
Polarization		X	X	X									
Return loss / VSWR		X		X									IEC 60835-2-2 [13]
Inter-port isolation		X		X									IEC 60835-2-2 [13]

ER = Essential Requirement

CR = Complementary Requirement

OR = Optional Requirement

SD = Supplier's Declaration

TR = Test Required

NOTE 1: SD is intended for proper selection among provided options or for information necessary to carry out the test.

NOTE 2: The environmental conditions at the time of test would be recorded in the test report. This declaration will also guarantee that the essential requirements shall be met for the environmental conditions given in clause 5.1.5 and clause 5.1.6.

NOTE 3: Alternative test methods may be agreed prior to testing.

NOTE 4: CS only.

NOTE 5: Multi-beam antennas only.

Clear distinction is made between "Essential Requirements (ER)" which require "Approval Testing" for regulatory purpose and "Complementary Requirements" (CR) or Optional Requirements (OR) which fulfil the "Conformance Testing" against the relevant standards.

The Type Approval Authority shall require the Supplier's Declaration which encompasses the test report demonstrating essential requirements (radiation pattern and gain), accompanied by evidence of accreditation to an internationally recognized Quality Standard, e.g. at least ISO 9001 [12].

The supplier shall be considered legally responsible for any statement in the declaration.

Annex A contains the Supplier's Declaration template for all the parameters in table 1. Annex B contains the Test Report template for the essential requirements listed in table 1.

Test methods adopted should be in general accordance with IEC 60835-2-2 [13], although suitable alternative test methods may be agreed between the Supplier and the Type Approval Authority prior to testing. A description of the test method is to be included in the test report, including test configuration.

4.2 Implementation under test (IUT)

The IUT presented for Type Approval shall be representative of a production model.

The present document applies to both integrated and non-integrated antennas.

In the case of an antenna separate from the radio equipment, testing shall be conducted at point D (D') in figure 1.

An appropriate adapter shall be used if required to connect the antenna to the test equipment and the effects of the adapter upon the test results shall be taken into account and declared.

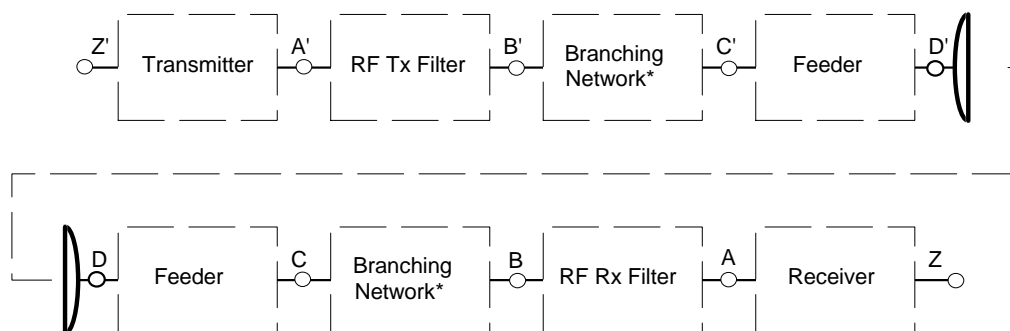

Figure 1: PMP system block diagram

Figure 1 is consistent with that used in many P-MP and P-P equipment standards. However, some P-MP systems use various types of diversity or bistatic / multi-antenna schemes. In all cases the supplier shall identify and define the appropriately accessible antenna ports. In some arrangements (monostatic), receive and transmit functions use the same antenna port.

5 Supplier's Declaration

5.1 General characteristics

5.1.1 Frequency range

The frequency range from those quoted in the relevant standard shall be stated.

5.1.1.1 Frequency band

The operational frequency band of the antenna shall be stated and measurements shall be carried out as a minimum at the lowest, middle and highest frequency of the relevant band.

5.1.2 Class of antenna RPE

The class of antenna RPE from within the declared frequency range of the relevant antenna standard shall be stated.

5.1.3 Sector angle

For a sectored antenna, the sector angle shall be stated.

For multi-beam antenna, the beam width and the reference directions shall also be stated.

5.1.4 Gain

The minimum gain from within the declared frequency range of the relevant antenna standard shall be stated.

Where appropriate the gain category from within the declared frequency range of the relevant antenna standard shall be stated.

5.1.5 Environmental characteristics

The supplier shall declare the temperature range and the wind survival rating of the antenna. Guidance information on antenna environmental characteristics may be found in the relevant antenna standard.

5.1.6 Antenna stability

The supplier shall declare the operational conditions under which the antenna shall remain stable. Guidance information on antenna stability may be found in the relevant antenna standard.

5.1.7 Antenna input connector

The supplier shall declare that the antenna input connector(s) conforms to ISO/IEC 15485 [14], IEC 60169 [15] and/or other manufacturers' proprietary connection designs. See also clause A.2 of the corresponding standard, especially for integrated antennas.

5.1.8 RL/VSWR

The supplier shall declare the minimum return loss value and/or the maximum VSWR over the operational frequency band.

The supplier shall declare the configuration used during the test. See also clause 4.2 of the present document and clause A.2 of the corresponding standard, especially for integrated antennas.

5.1.9 Inter-port isolation

For antennas with two or more input ports the supplier shall declare the minimum inter-port isolation over the operational frequency band.

5.1.10 Polarization

The supplier shall declare the nominal polarization of the antenna.

6 Test procedures for essential requirements

Where necessary, for better understanding of the application of test methods, reference is made to IEC 60835-2-2 [13] (Test methods).

Alternative test methods, among them compact antenna test ranges or near-field scan, may be agreed between the Supplier and the Type Approval Authority prior to testing.

All measurements made on linearly polarised antennas shall be made using linearly polarised transmitting antennas. For circularly polarised antennas, either circularly or linearly polarised transmitting antennas may be used. Where circularly polarised antennas are measured with linearly polarised transmitting antennas, the received signals may be combined mathematically to yield the co-polar and cross-polar performance and the antenna gain.

6.1 Radiation Pattern Envelope (RPE)

Objective:

To verify that the antenna radiation pattern, for the declared class and frequency range, is contained within the limits of the stated RPE from the relevant standard. This covers both azimuth and elevation, as applicable.

Test instruments and set-up:

Figure 2 shows a typical test set-up.

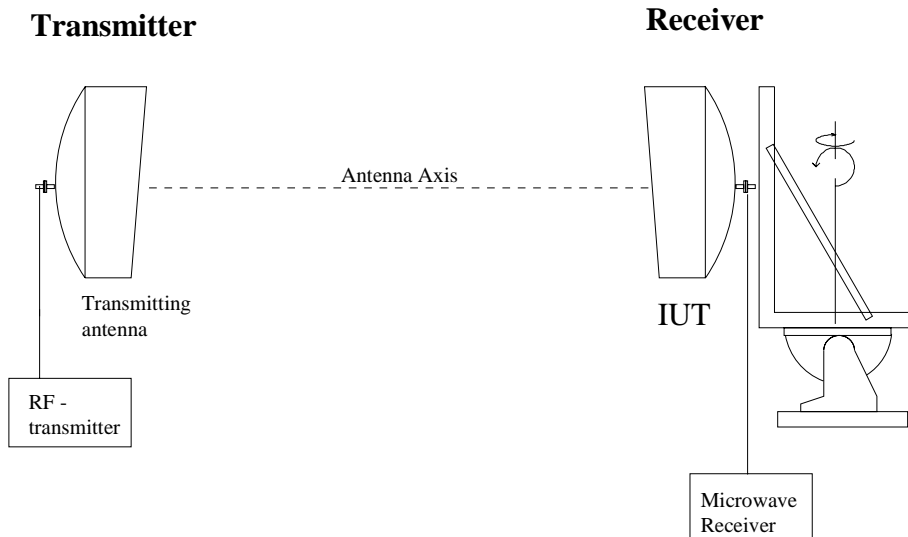

Figure 2: Example of arrangement for the measurement of the radiation pattern

Test procedure:

The test methods described in IEC 60835-2-2 [13] are generally applicable. The antenna shall be measured as a minimum at the lowest, middle and highest of the declared frequency band.

The cross-polar radiation patterns shall be recorded after an alignment procedure based on the minimization of the cross-polar level in the frequency band of the antenna, where applicable. In all other cases, the antenna is to be aligned for test with its primary mechanical axes. This mechanical setting shall be maintained for all the cross-polar measurements at all frequencies.

Test procedure example, for linearly polarised antenna (alternative test procedures could be used):

- a) Initial alignments are made at the centre frequency of the declared frequency band.
- b) Adjust the polarization of the IUT to be parallel or perpendicular to the azimuth plane containing the transmission axis.
- c) Align the azimuth and elevation of the transmitting antenna and the IUT for maximum co-polar signal.
- d) Change the polarization of the transmitting antenna to cross-polar.
- e) Adjust the polarization of the transmitting antenna to the minimum cross-polar level.
- f) Change the polarization of the transmitting antenna back to co-polar.
- g) Perform co and cross-polar pattern measurements at the middle frequency of the declared frequency band. In the case of single polarized antenna the alignment has to be repeated for the other polarization.
- h) Repeat the co and cross-polar pattern measurements for the lowest and highest frequency limits in the declared frequency band while maintaining the initial mechanical alignment determined for the middle frequency measurement.
- i) For multi-beam antenna, perform the above measurements for each of the beams.

For circularly polarised antennas, the same procedure may be used, but the right and left hand circular components may be extracted mathematically from the output of a linear transmitting antenna, or circularly polarised transmitting antennas may be used.

Only in the event of changes to the mechanical settings of the antenna (e.g. changing the measuring plane) shall the initial alignment a) to h) be repeated.

6.2 Antenna gain

Objective:

To verify that the measured gain, for the declared class, category gain and frequency range, satisfies the minimum gain stated in the relevant standard and to use the measured gain to normalize the RPE.

Test instruments and set-up:

Figures 3 and 4 show typical examples of gain measurement test set-ups; in these examples the antenna is taken as having a coaxial or waveguide port respectively.

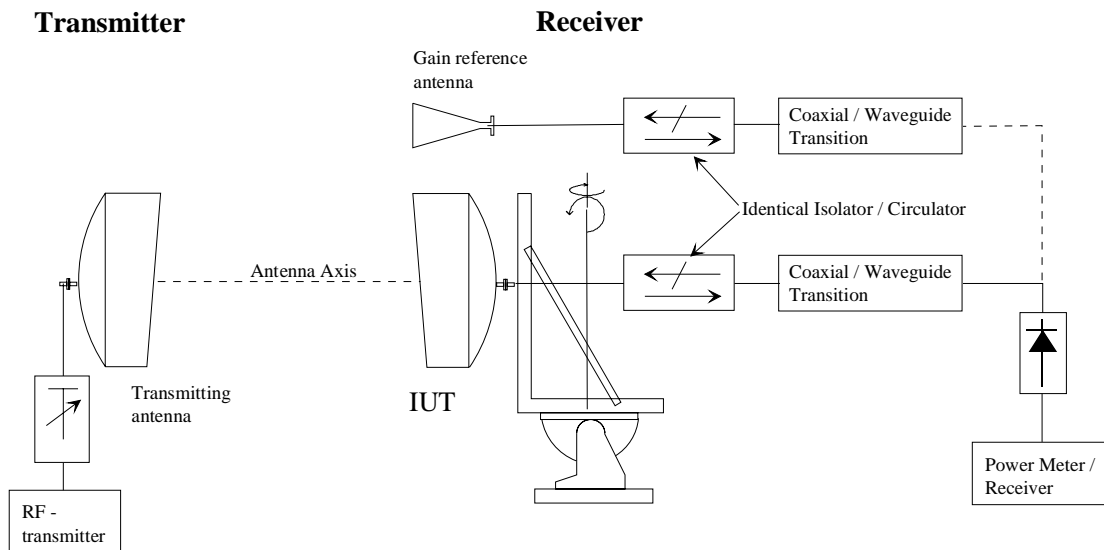

Figure 3a: Test set-up for gain measurement by comparison with a gain reference antenna, using coaxial cables

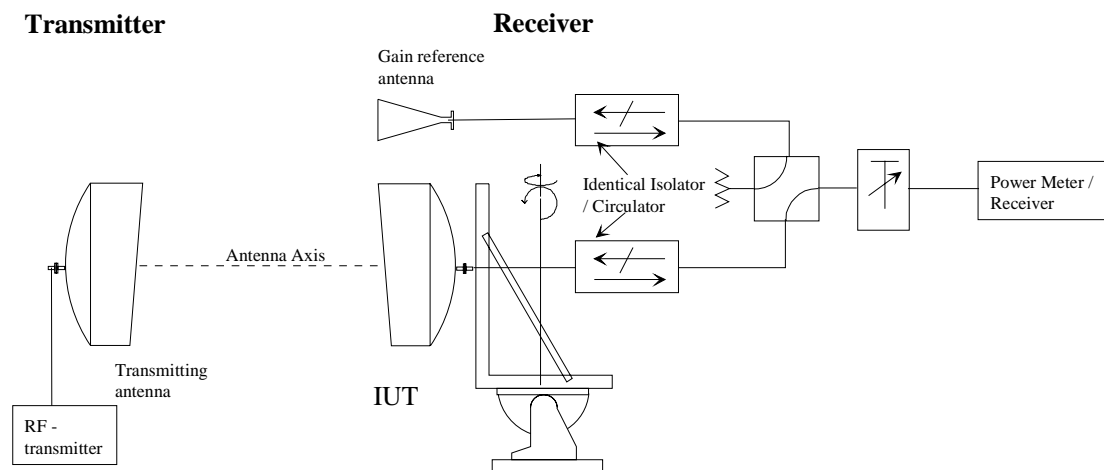

Figure 3b: Test set-up for gain measurement by comparison with a gain reference antenna, using waveguides

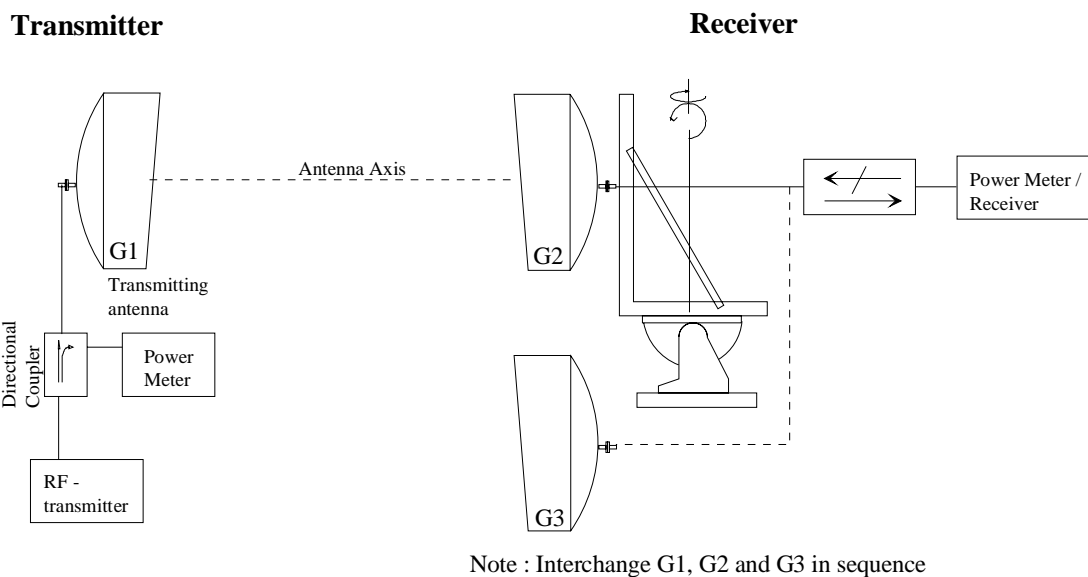

Figure 4a: Test set-up for gain measurement with three-antenna method

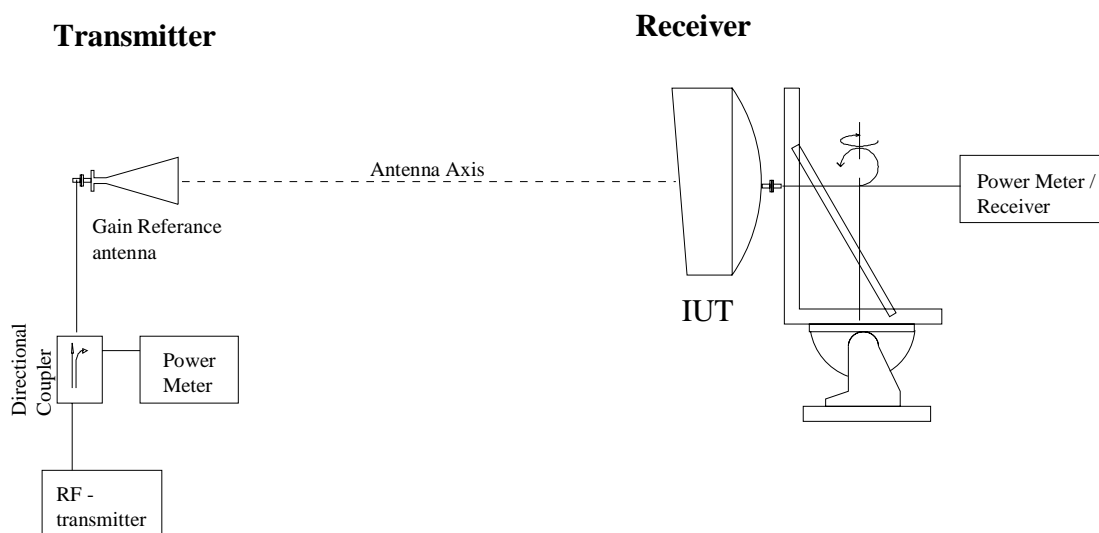

Figure 4b: Test set-up for gain measurement with direct method

Test procedure (alternative test procedures could be used):

The test methods described in IEC 60835-2-2 [13] are generally applicable. The antenna gain shall be measured as a minimum at the lowest, middle and highest of the declared frequency band.

The following test procedure is suggested for sectored and multi-beam antennas, which reflects the technical differences from the highly directional PP and TS antennas:

- a) Initial alignments are made at the centre frequency of the declared frequency band.
- b) Align the transmitting antenna in pointing direction and polarization orientation (for linearly polarised transmitting antennas only) and the IUT to the defined azimuth and elevation zero degree reference direction; , in the case of a circularly polarised IUT being measured with linearly polarised transmitting antennas, the gains may be summed to determine the overall antenna gain, when the transmit antenna has been rotated 90 degrees about the antenna axis and the gain measured a second time.
- c) Perform the gain measurement at the centre frequency.
- d) Repeat the gain measurements for the lowest and highest frequency while maintaining the mechanical alignment determined for the middle frequency.

The boresight gain can be calculated by normalizing the radiation pattern to the measured gain at the reference direction stated in the present document, as shown in the figures.

For multi-beam antenna the gain of each beam will be measured separately.

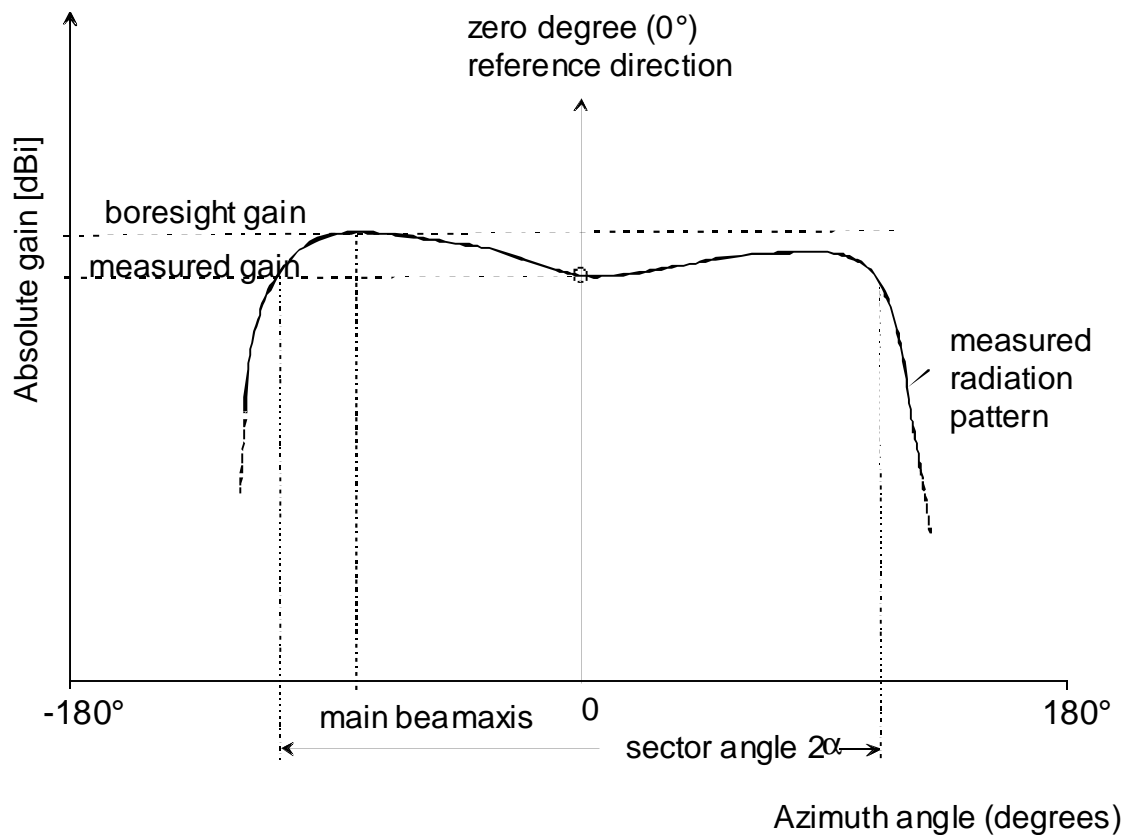

Figure 5: Example of sectored antenna gain measurement

6.3 Other antenna characteristics

6.3.1 Passive intermodulation, VSWR and inter-port isolation

The above parameters are not required by the normative parts of the current antenna standards.

Passive intermodulation is important for some P-MP systems, but there is no standard procedure for this measurement.

Active antennas are specifically not covered in the current standards.

Annex A (normative): Supplier's Declaration

A.1 Supplier's Declaration against the essential parameters

The Supplier's Declaration is not complete without the inclusion of the "place and date of issue "and the "name and signature or equivalent marking of authorized person".

Hereby We

.....
(company name)

.....
.....
.....
(company address)

declare under our sole responsibility that the product

.....
(detailed description, including name, type model and frequency band)

is produced under the conditions of a full quality system with the registration number:

.....
(registration number)

and it is in conformity with the following standard(s) (ETS/EN) or other normative document(s):

.....
(ETS/EN number): Frequency range

.....
(Frequency band)

.....
(RPE class)

.....
(Sector angle, or beam angles and reference beam directions, if applicable)

.....
(Minimum boresight gain / gain category)

.....
(Antenna polarization)

following the provisions of Directives 91/263/EEC and 98/13/EC.

.....
 (if applicable) following the provisions ofDirective

A.2 Supplier's Declaration against the complementary/optional parameters

We also declare that the product is in conformance with the following general characteristics. No test data or other evidence is supplied for these parameters in the conformance test report.

A.2.1 Environmental characteristics

A.2.1.1 Temperature range

The antenna has been designed to provide useful performance over the following temperature range:

-33°C to +40°C	
-45°C to +45°C	
Other	

A.2.1.2 Wind survival

One of the following wind survival ratings should be declared for the antenna under test:

Antenna type	Wind velocity m/s (km/h)	Ice load (density 7 kN/m ³)	
Normal duty	55 (200)	25 mm radial ice	
Heavy duty	70 (252)	25 mm radial ice	
Other			

A.2.2 Antenna stability

One of the following stability ratings should be declared for the antenna under test:

Antenna type	Wind velocity m/s (km/h)	Ice load (density 7 kN/m ³)	
Normal duty	30 (110)	25 mm radial ice	
Heavy duty	45 (164)	25 mm radial ice	
Other			

A.2.3 Antenna input connectors

The type of antenna input connector is as follows:

System Type	Y / N
integrated	
non-integrated	

Antenna input connector type(specify)	
Standard - coaxial - waveguide	
Proprietary - coaxial - waveguide	

A.2.4 RL/VSWR

The RL/VSWR limit is as follows:

RL Minimum [dB]	
VSWR Maximum	

A.2.5 Inter-port isolation

The worst case inter-port isolation limit for multi-beam antennas, and , if applicable, for single beam antennas, is as follows:

Inter-port isolation minimum [dB]	
-----------------------------------	--

.....

(place and date of issue) (name and signature or equivalent marking of authorized person)

Conformance Test Report reference (insert doc. reference)	
--	--

A.3 Supplementary information (if applicable)

For example (as requested by some regulatory authorities):

.....

(Nominal gain)

.....

(Other)

.....

End of the Supplier's Declaration

.....

Annex B (normative): Test report

B.1 Test results

B.1.1 Summary of tests

Parameter	C	NC	Reference to remark
Radiation Pattern Envelope (RPE)			
Antenna gain			
C: The parameter is Compliant with the requirements.			
NC: The parameter is Not Compliant with the requirements.			

B.1.2 General information about the tests

General information about the tests shall be given below.

Name of Laboratory carrying out the tests Test report reference number Standard applied Dates of test (from - to) Name of manufacturer Antenna Model Type number (s) Antenna Module Description Reflector (if applicable) Feed horn (if applicable) Radome (if applicable) RF connector / flange Other	Type and serial number (if applicable)
---	--

Brief description of the configuration used under test:

.....

.....

.....

B.1.3 Test result forms

B.1.3.1 Radiation Pattern Envelope (RPE)

B.1.3.1.1 Azimuth co-polar radiation patterns

The co-polar radiation patterns measured as a minimum at the lowest, middle and highest of the declared frequency band shall be provided.

For multi-beam antennas, the radiation pattern for each beam shall be provided.

Co-polar radiation pattern

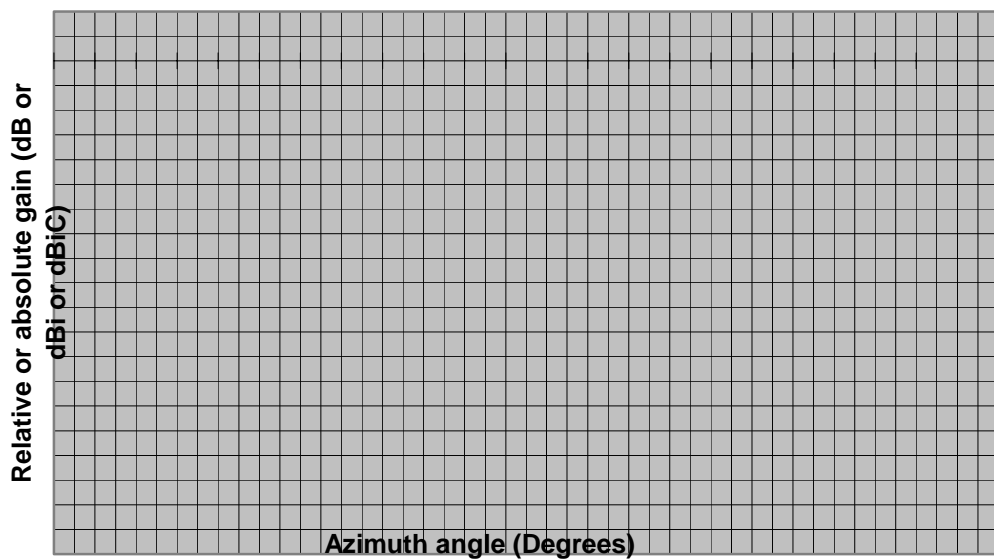

-180°

180°

Antenna model type number	
Frequency	
Polarization	

The radiation patterns shall be provided on separate graphs for clarification. The option for overlaying the RPEs, as detailed in the relevant standard, could be adopted.

If necessary for clarification, an appropriate enlarged scale should be used to present the test results.

As a guide the plots should be provided on a minimum of 80% of A4.

B.1.3.1.2 Azimuth cross-polar radiation patterns

The cross-polar radiation patterns measured as a minimum at the lowest, middle and highest of the declared frequency band shall be provided.

For multi-beam antennas, the radiation pattern for each beam shall be provided.

Cross-polar radiation pattern

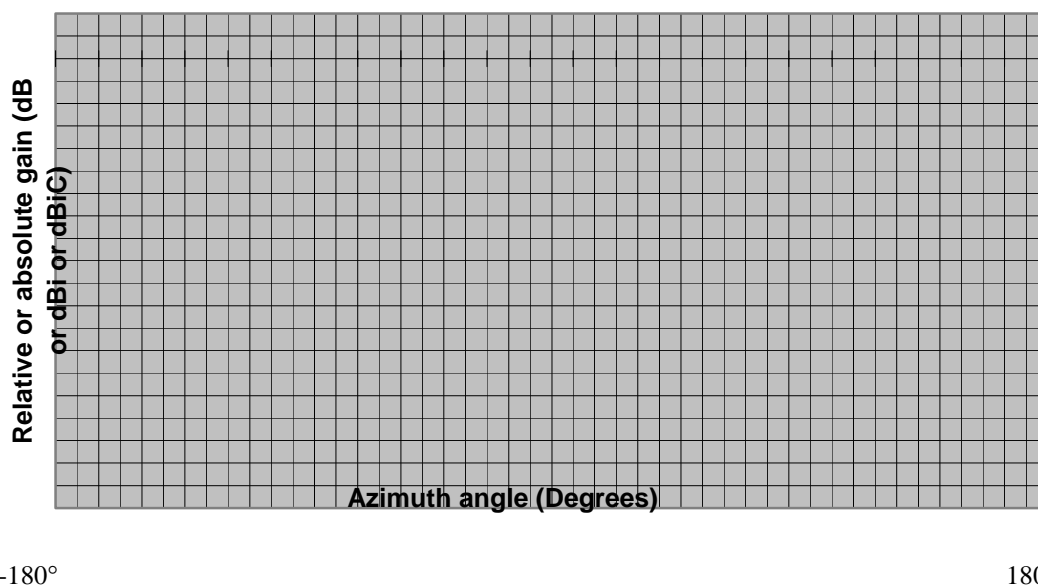

Antenna model type number	
Frequency	
Polarization	

The radiation patterns shall be provided on separate graphs for clarification. The option for overlaying the RPEs, as detailed in the relevant standard, could be adopted.

If necessary for clarification an appropriate enlarged scale should be used to present the test results.

As a guide the plots should be provided on a minimum of 80% of A4.

B.1.3.1.3 Elevation co-polar radiation patterns

The co-polar radiation patterns measured as a minimum at the lowest, middle and highest of the declared frequency band shall be provided.

For multi-beam antennas, the radiation pattern for each beam shall be provided.

Co-polar radiation pattern

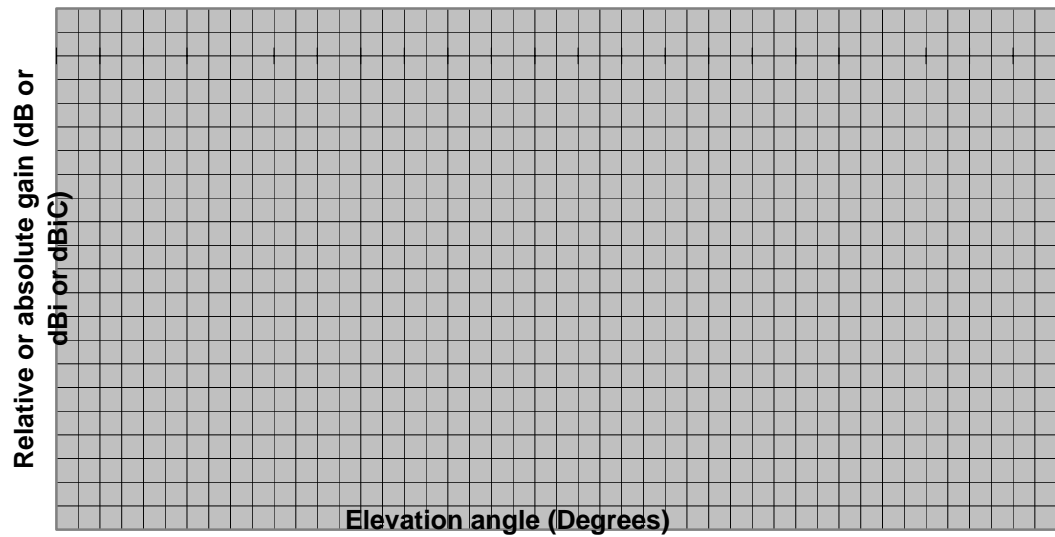

-180°

180°

Antenna model type number	
Frequency	
Polarization	

The radiation patterns shall be provided on separate graphs for clarification. The option for overlaying the RPEs, as detailed in the relevant standard, could be adopted.

If necessary for clarification, an appropriate enlarged scale should be used to present the test results.

As a guide the plots should be provided on a minimum of 80% of A4.

B.1.3.1.4 Elevation cross-polar radiation patterns

The cross-polar radiation patterns measured as a minimum at the lowest, middle and highest of the declared frequency band shall be provided.

For multi-beam antennas, the radiation pattern for each beam shall be provided.

Cross-polar radiation pattern

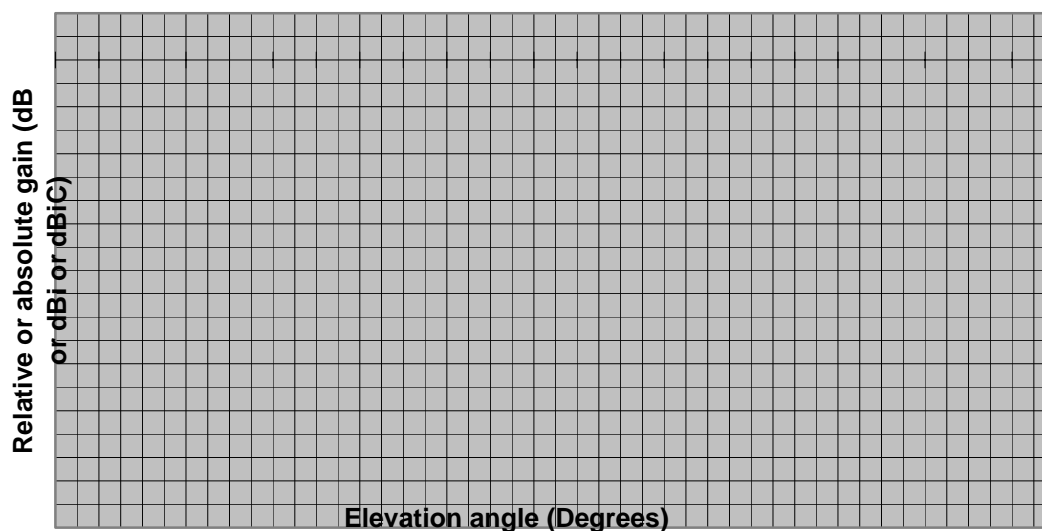

-180°

180°

Antenna model type number	
Frequency	
Polarization	

The radiation patterns shall be provided on separate graphs for clarification. The option for overlaying the RPEs, as detailed in the relevant standard, could be adopted.

If necessary for clarification, an appropriate enlarged scale should be used to present the test results.

As a guide the plots should be provided on a minimum of 80% of A4.

B.1.3.2 Antenna gain

As a minimum the antenna gain shall be recorded for the lowest, middle and highest of (the declared frequency band).

For multi-beam antennas, the gain shall be recorder for each beam.

Frequency [GHz]	Lowest frequency	Middle frequency	Highest frequency
Antenna gain [dBi or dBiC]			

In the case of dual polarized antennas a clear indication of the polarization of the input port shall be stated.

The method used in the gain measurement shall be declared.

B.1.3.3 Environmental conditions during the test

The environmental conditions during the test shall be recorded. If the environmental conditions cause the test results to be affected then this is to be stated.

B.1.4 Measurement accuracy

The radiation pattern measurements must be performed at test sites where attempts are made to suppress the effects of reflected signals from the surroundings and eventual radio interference is controlled EN 300 833 [6].

The level of the reflections has to be used in the declaration of the uncertainty of the measurements.

In the event the measurement is significantly affected by reflections or interference, this shall be clearly detailed in the test report. The latter may include the level of reflections as determined from special verification(s) undertaken with reference antennas, time gating or other techniques. Guidance material may be found in annex C.

The two parameters to be considered in the measurements of antennas are:

- 1) the amplitude of the received signal (expressed in dB);
- 2) the angular position of the antenna under test, generally referred to the main beam axis.

As guideline, for the calculation of the accuracy, see the document Standard ISO TAG4 (see bibliography).

B.1.4.1 Gain measurement accuracy

Where substitution techniques are used particular attention to the following parameters should be noted.

With respect to the amplitude, the measurement accuracy shall be derived over the complete dynamic range, and in particular the following parameters should be taken into account:

- receiver linearity (between the IUT and the reference antenna measured levels);
- receiver sensitivity;
- reflectivity of the test set-up;
- mismatch between the antennas (IUT and reference one) and the measurement port of the set-up;
- accuracy of the calibration of the reference antenna;
- misalignment of the IUT and reference antenna.

B.1.4.2 Co-polar and cross-polar radiation patterns measurement accuracy

With respect to the amplitude, the measurement accuracy shall be derived over the complete dynamic range and in particular the following parameters should be taken into account:

- receiver linearity;
- receiver sensitivity;
- reflectivity of the test set-up.

In the comparison with the mask of the relevant standard the overall accuracy of the measured radiation pattern shall also include the gain accuracy.

Annex C (informative): Test site description

It may be necessary to provide a sketch of the test site as part of the Test Report, showing possible sources of reflections and terrain details, i.e. side profile and overall view. The critical angles in the test site should be clearly identified to guarantee the accuracy of the measurements.

Example of test site description:

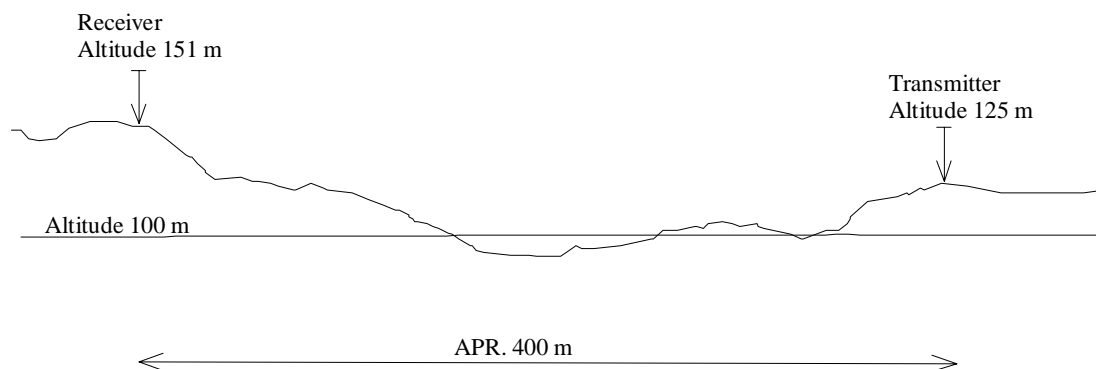

Figure C.1: Terrain profile

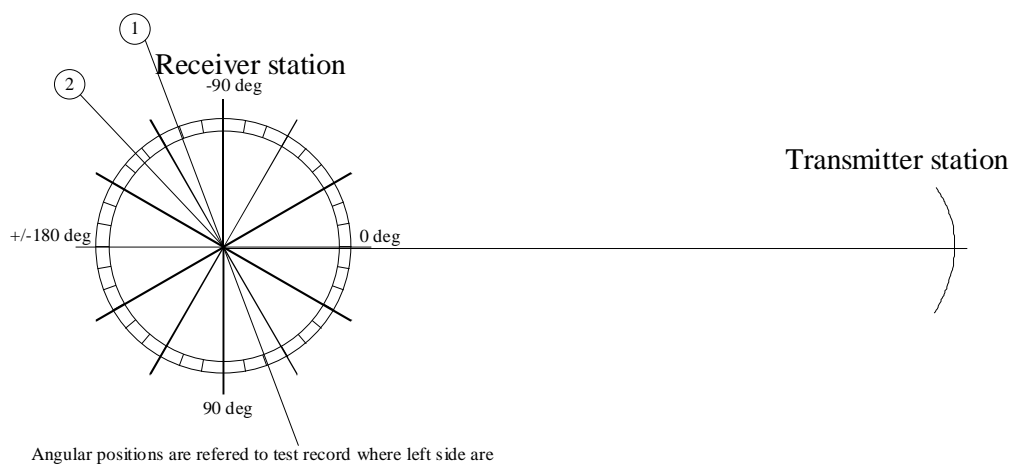

Figure C.2: Typical interference chart with reflections from buildings and structures or radio interferences

Table C.1: Example of table of interference

No.	Interference type	Interference source	Distance to source	Additional information
1	Radio link		23 km	
2	Reflection	Tree	120 m	

C.1 Test equipment used for tests

In the following table, the test equipment used for the test shall be listed by the test laboratory.

In each separate part of the test report the used test equipment shall be stated. The instruments are then identified by a number which refers to the table below.

No.	Test equipment	Type	Manufacturer	Reference number	Calibration due day
01					
02					
03					
04					
05					
06					
07					
08					
09					
10					

C.2 Supplementary information (if applicable)

Remarks:

.....

.....

Annex D (informative): Bibliography

- EN 45014 (1989): "General criteria for suppliers declaration of conformity".
- ISO TAG4 WG3 1992: "Guide to the Expression of Uncertainty in measurement".

History

Document history		
V1.1.1	March 2001	Publication
V1.2.1	July 2003	One-step Approval Procedure OAP 20031128: 2003-07-30 to 2003-11-28