

Final draft **ETSI EN 301 126-2-6** V1.1.1 (2001-12)

---

*European Standard (Telecommunications series)*

**Fixed Radio Systems;  
Conformance testing;  
Part 2-6: Point-to-Multipoint equipment;  
Test procedures for Multi Carrier  
Time Division Multiple Access (MC-TDMA) systems**

---



---

Reference

DEN/TM-04026-2-6

---

Keywords

DRRS, point-to-multipoint, testing, transmission

**ETSI**

650 Route des Lucioles  
F-06921 Sophia Antipolis Cedex - FRANCE

Tel.: +33 4 92 94 42 00 Fax: +33 4 93 65 47 16

Siret N° 348 623 562 00017 - NAF 742 C  
Association à but non lucratif enregistrée à la  
Sous-Préfecture de Grasse (06) N° 7803/88

---

**Important notice**

Individual copies of the present document can be downloaded from:

<http://www.etsi.org>

The present document may be made available in more than one electronic version or in print. In any case of existing or perceived difference in contents between such versions, the reference version is the Portable Document Format (PDF). In case of dispute, the reference shall be the printing on ETSI printers of the PDF version kept on a specific network drive within ETSI Secretariat.

Users of the present document should be aware that the document may be subject to revision or change of status. Information on the current status of this and other ETSI documents is available at

<http://portal.etsi.org/tb/status/status.asp>

If you find errors in the present document, send your comment to:

[editor@etsi.fr](mailto:editor@etsi.fr)

---

**Copyright Notification**

No part may be reproduced except as authorized by written permission.  
The copyright and the foregoing restriction extend to reproduction in all media.

© European Telecommunications Standards Institute 2001.  
All rights reserved.

---

# Contents

Intellectual Property Rights .....	4
Foreword.....	4
1 Scope .....	5
2 References .....	5
3 Definitions, symbols and abbreviations .....	5
3.1 Definitions .....	5
3.2 Symbols.....	5
3.3 Abbreviations .....	6
4 General characteristics .....	6
4.1 Equipment configuration.....	7
4.1.1 System configuration .....	8
4.2 Transmitter characteristics.....	9
4.2.1 Maximum RF output power .....	9
4.2.2 Minimum RF output power (if applicable).....	10
4.2.3 Automatic Transmit Power Control (ATPC).....	10
4.2.4 Remote Transmit Power Control (RTPC).....	11
4.2.5 Frequency accuracy .....	11
4.2.6 RF spectrum mask .....	12
4.2.7 Remote frequency control.....	13
4.2.8 Spectral lines at the symbol rate .....	13
4.2.9 Spurious emissions (external) .....	13
4.3 Receiver characteristics .....	14
4.3.1 Input level range (if applicable).....	14
4.3.2 Spurious emissions .....	15
4.4 System characteristics .....	15
4.4.1 Dynamic level range .....	15
4.4.2 BER as a function of receiver input signal level RSL .....	16
4.4.3 Equipment Background BER.....	17
4.4.4 Interference sensitivity.....	18
4.4.4.1 Co-channel interference sensitivity .....	18
4.4.4.2 Adjacent RF-channel interference sensitivity .....	20
4.4.4.3 CW spurious interference.....	21
History .....	23

---

## Intellectual Property Rights

IPRs essential or potentially essential to the present document may have been declared to ETSI. The information pertaining to these essential IPRs, if any, is publicly available for **ETSI members and non-members**, and can be found in ETSI SR 000 314: "*Intellectual Property Rights (IPRs); Essential, or potentially Essential, IPRs notified to ETSI in respect of ETSI standards*", which is available from the ETSI Secretariat. Latest updates are available on the ETSI Web server (<http://webapp.etsi.org/IPR/home.asp>).

Pursuant to the ETSI IPR Policy, no investigation, including IPR searches, has been carried out by ETSI. No guarantee can be given as to the existence of other IPRs not referenced in ETSI SR 000 314 (or the updates on the ETSI Web server) which are, or may be, or may become, essential to the present document.

---

## Foreword

This European Standard (Telecommunications series) has been produced by ETSI Technical Committee Transmission and Multiplexing (TM), and is now submitted for the Vote phase of the ETSI standards Two-step Approval Procedure.

The present document is part 2-6 of a multi-part deliverable covering the Fixed Radio Systems, Conformance testing, as identified below:

- Part 1: "Point-to-point equipment - Definitions, general requirements and test procedures";
- Part 2-1: "Point-to-Multipoint equipment; Definitions and general requirement";
- Part 2-2: "Point-to-Multipoint equipment; Test procedures for FDMA systems";
- Part 2-3: "Point-to-Multipoint equipment; Test procedures for TDMA systems";
- Part 2-4: "Point-to-Multipoint equipment; Test procedures for FH-CDMA systems";
- Part 2-5: "Point-to-Multipoint equipment; Test procedures for DS-CDMA systems";
- Part 2-6: "Test procedures for Multi Carrier Time Division Multiple Access (MC-TDMA) systems";**
- Part 3-1: "Point-to-Point antennas; Definitions, general requirements and test procedures";
- Part 3-2: "Point-to-Multipoint antennas - Definitions, general requirements and test procedures".

The present document defines harmonized test methods for the conformity assessment testing of point-to-multipoint fixed radio systems applying Multi Carrier Time Division Multiple Access Method (MC-TDMA). It should be noted that this part six can only be applied in conjunction with part one.

EN 301 126-2-1 [2] defines the conformity assessment testing requirements (definitions and general requirements) for radio specific parameters required directly by the relevant EN/ETS for point-to-multipoint systems. Annex A of EN 301 126-2-1 [2] contains the supplier's declaration. Annex B contains the test report format.

Parts 2, 3, 4 and 5 contain the appropriate test procedures for the other access methods.

It is recommended that where a clarification of a test procedure or an agreed test procedure is required, this should be described on the final page of the test report titled "Additional information supplementary to the test report".

<b>Proposed national transposition dates</b>	
Date of latest announcement of this EN (doa):	3 months after ETSI publication
Date of latest publication of new National Standard or endorsement of this EN (dop/e):	6 months after doa
Date of withdrawal of any conflicting National Standard (dow):	6 months after doa

---

# 1 Scope

The present document details standardized test procedures for conformance testing of equipment for Point-to-Multipoint (P-MP) digital radio relay systems applying Multi Carrier Time Division Multiple Access method (MC-TDMA).

Standardized procedures are required in order to fulfil CEPT/ERC/DEC/(97) 10 [1] on the mutual recognition, within CEPT, of the results of conformance tests on equipment carried out in individual CEPT Countries. Furthermore the procedures described in the present document are relevant to be able to fulfil the conformance assessment procedure described in chapter II of the Directive 1999/5/EC [3] in order to demonstrate the compliance of the DRRS with the relevant essential requirements identified in article 3 of the R&TTE Directive [3].

The present document is intended to be applied in conjunction with EN 301 126-2-1 [2] and in conjunction with the individual equipment ENs/ETSS describing TDMA methods and will enable commonality of test results, irrespective of the Supplier or the Notified Body carrying out the test.

The conformance tests described in the present document are those related to radio specific parameters required directly by the relevant radio relay ENs/ETSS. Conformance tests to other boundary EN/ETS (e.g. those for system input/output interfaces and related base band process) are outside the scope of the present document.

---

# 2 References

The following documents contain provisions which, through reference in this text, constitute provisions of the present document.

- References are either specific (identified by date of publication and/or edition number or version number) or non-specific.
- For a specific reference, subsequent revisions do not apply.
- For a non-specific reference, the latest version applies.

- [1] CEPT/ ERC/DEC(97)10: "ERC Decision of 30 June 1997 on the mutual recognition of conformity assessment procedures including marking of radio equipment and radio terminal equipment".
- [2] ETSI EN 301 126-2-1: "Fixed Radio Systems; Conformance testing; Part 2-1: Point-to-Multipoint equipment; Definitions and general requirements".
- [3] Directive 1999/5/EC of the European Parliament and of the Council of 9 March 1999 on radio equipment and telecommunications terminal equipment and the mutual recognition of their conformity (R&TTE Directive).
- [4] EN 60835: "Methods of measurement for equipment used in digital microwave radio transmission systems".
- [5] CEPT/ERC/REC 74-01E: "Spurious emissions".

---

# 3 Definitions, symbols and abbreviations

## 3.1 Definitions

For the purposes of the present document, the terms and definitions given in EN 301 126-2-1 [2] apply.

## 3.2 Symbols

For the purposes of the present document, the symbols given in EN 301 126-2-1 [2] apply.

### 3.3 Abbreviations

For the purposes of the present document, the abbreviations defined in EN 301 126-2-1 [2] apply.

---

## 4 General characteristics

Where necessary, for better understanding of the application of test methods, reference is made to EN 60835 [4] (Test methods).

General remarks:

Where systems transmitting more than one carrier over the same Tx (Multi Carrier TDMA system) all carriers being modulated according to the relevant standard, have to be tested applying for each carrier the test procedures defined for a single carrier solution where not otherwise stated in the relevant EN/ETS. Where the transceiver can simultaneously support multiple modulation schemes, within the ITU/CEPT channel plan, (i.e. the sub carriers support different modulation schemes, 4 level, 16, level, 64 level etc., at the same time, with sub carriers on at least two different modulation schemes) then the system must meet the tightest transmission mask, or tightest composition transmitter mask for the possible modulation schemes. Likewise the more sensitive RSL and most stringent Co and adjacent BER requirements shall be meet. This requirement is necessary for planning purposes. Where the transceiver covers multiple modulation schemes, but only operates on one scheme at any time, then it shall be tested against that modulation scheme.

### 4.1 Equipment configuration

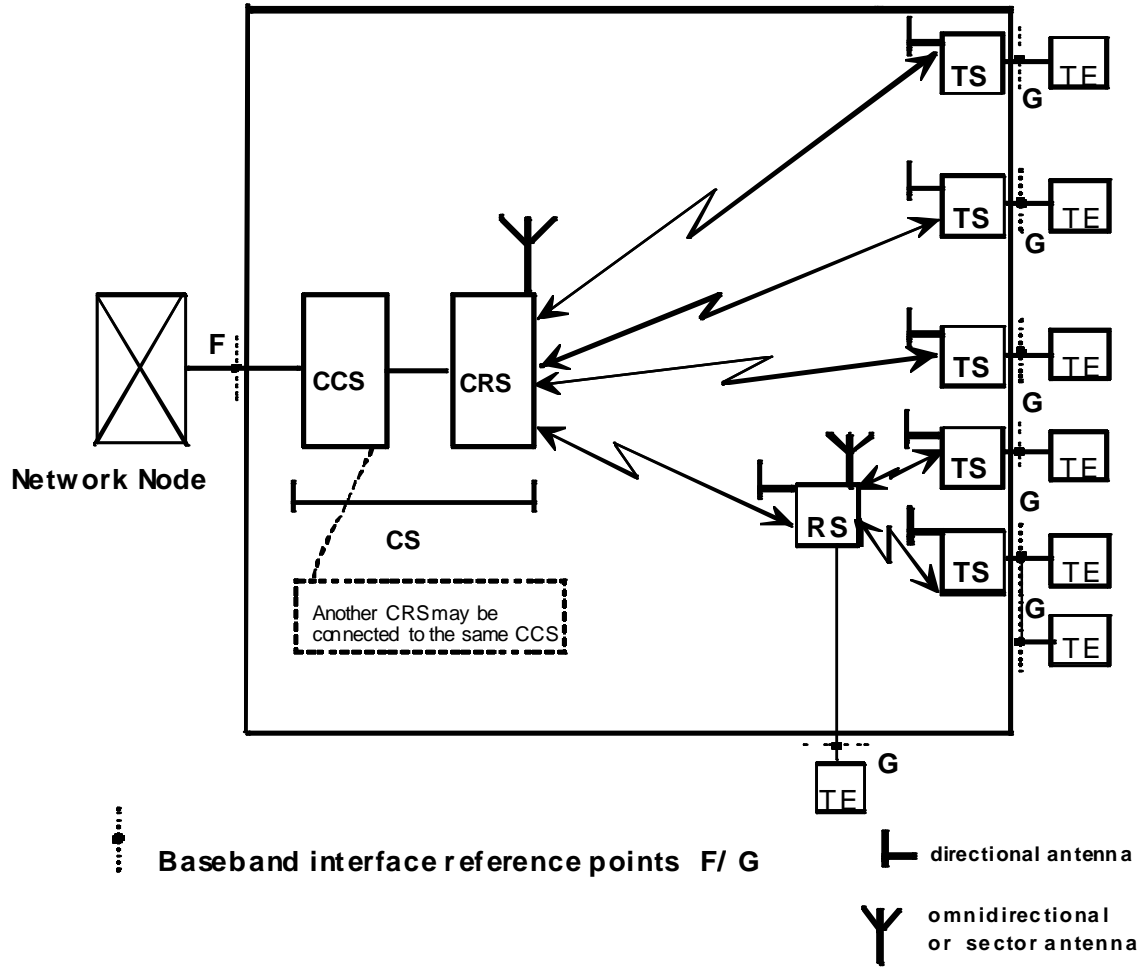

CCS Central Control Station  
 CRS Central Radio Station  
 CS Central Station  
 RS Repeater Station  
 TE Terminal Equipment  
 TS Terminal Station

**Figure 1: General system architecture**

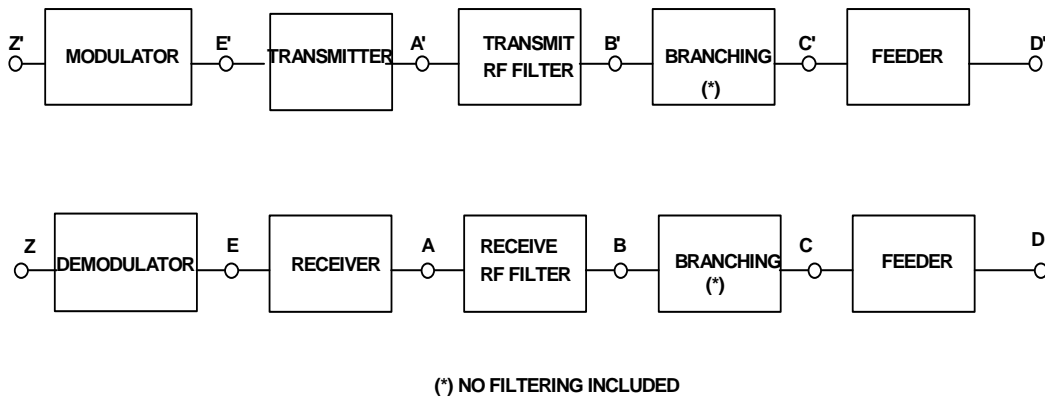
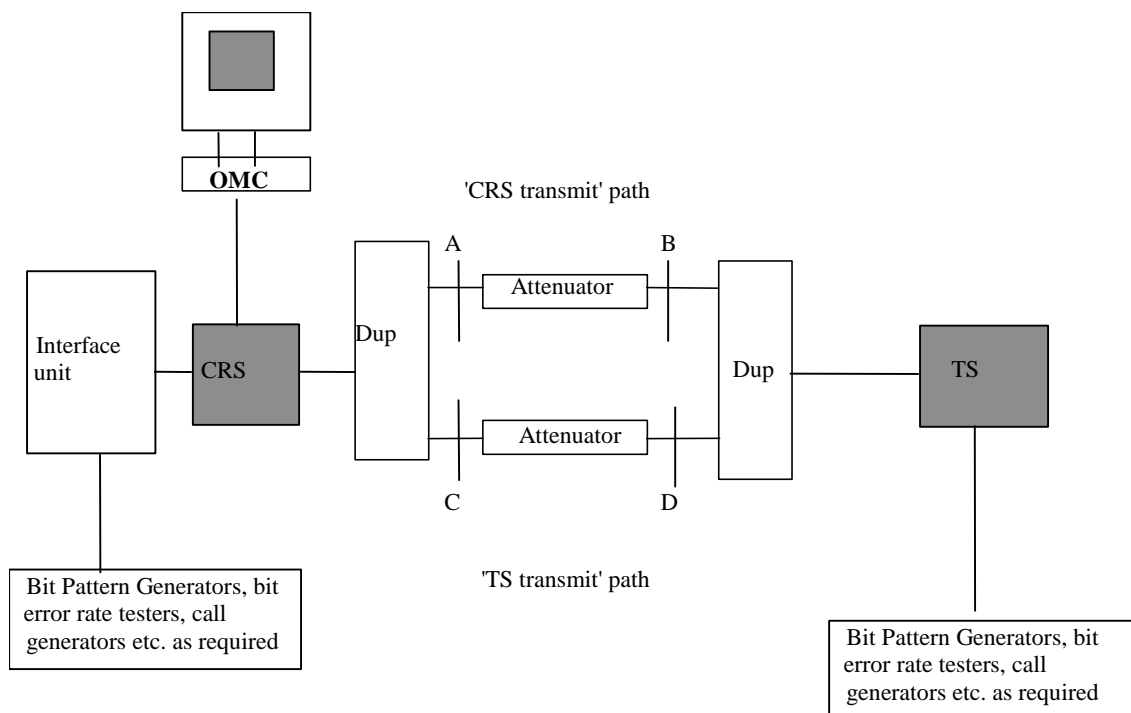

**Figure 2: RF system block diagram**

### 4.1.1 System configuration

P-MP equipment is designed to operate as an access system connected to a network node (e.g. local switch) and user terminal equipments (see figure 1). The individual conformance tests are made in a single link direction (see figure 2) but for certain tests, e.g. for equipment to set up signalling, both forward and reverse links have to operate, the minimum equipment arrangement for tests with only one subscriber is shown in figure 3, where the forward and return RF paths are separated by a pair of duplexers and separate attenuators are inserted in each path. In the absence of any more specific instructions from the supplier it is suggested that the links are operated at threshold (RSL) + n dB where n is half of the link dynamic range except when the receiver is being tested. The other receiver(s) should continue to be operated at threshold (RSL) + n dB.

Calibrated splitters or directional couplers will be inserted at points A, B, C and D (see figures 3 and 4) as required for the individual tests, either to provide test points or sources of interfering signals.



NOTE: TDD systems may only require a single path with one attenuator.

**Figure 3: Test configuration for a single Terminal Station**

NOTE 1: Calibrated splitters or directional couplers will be inserted at points A, B, C and D as required for the individual tests, either as test points or as sources of interfering signals.

NOTE 2: When measuring the TS transmitter to demonstrate that it meets the emission mask and spurious emissions limits, the splitter network will have only one TS connected and this network may be removed.

NOTE 3: The P-MP systems to be tested are duplex systems and features such as time/frequency synchronization and ATPC require both paths to be functioning correctly. To ensure that the results of measurements on either the forward or return paths, e.g. receiver RSL, are not influenced by conditions in the other path it may be necessary to provide lower attenuation, or raise the transmitter power, in this other path. In the absence of any more specific instructions from the supplier it is suggested that this other path is operated at threshold (RSL) + n dB.

All the test procedures, presented in the following clauses below, shall apply to both CRS(s) and TS(s). Unless otherwise stated, all essential requirements (ER) tests shall be undertaken at the nominal and extremes of power supply and environmental parameters and at maximum output power. RF power, spectrum and frequency measurements shall be undertaken at top, middle and bottom frequencies within the declared range of frequencies. These RF frequencies may be selected by remote control or otherwise.



Central or remote stations incorporating integral antennas shall be provided with an appropriate coaxial or wave guide transition by the supplier in order to facilitate the measurements described.

For tests where the simultaneous use of several TSs is necessary, then an arrangement similar to that shown in figure 4 is required. To enable communication, the traffic load may be simulated and facilities such as remote loop back may be used to route traffic through the system.

This arrangement ensures that the system operates in a normal manner similar to its configuration for measurements such as transmitter mask and RSL.

NOTE 4: TDD systems may only require a single path with one attenuator.

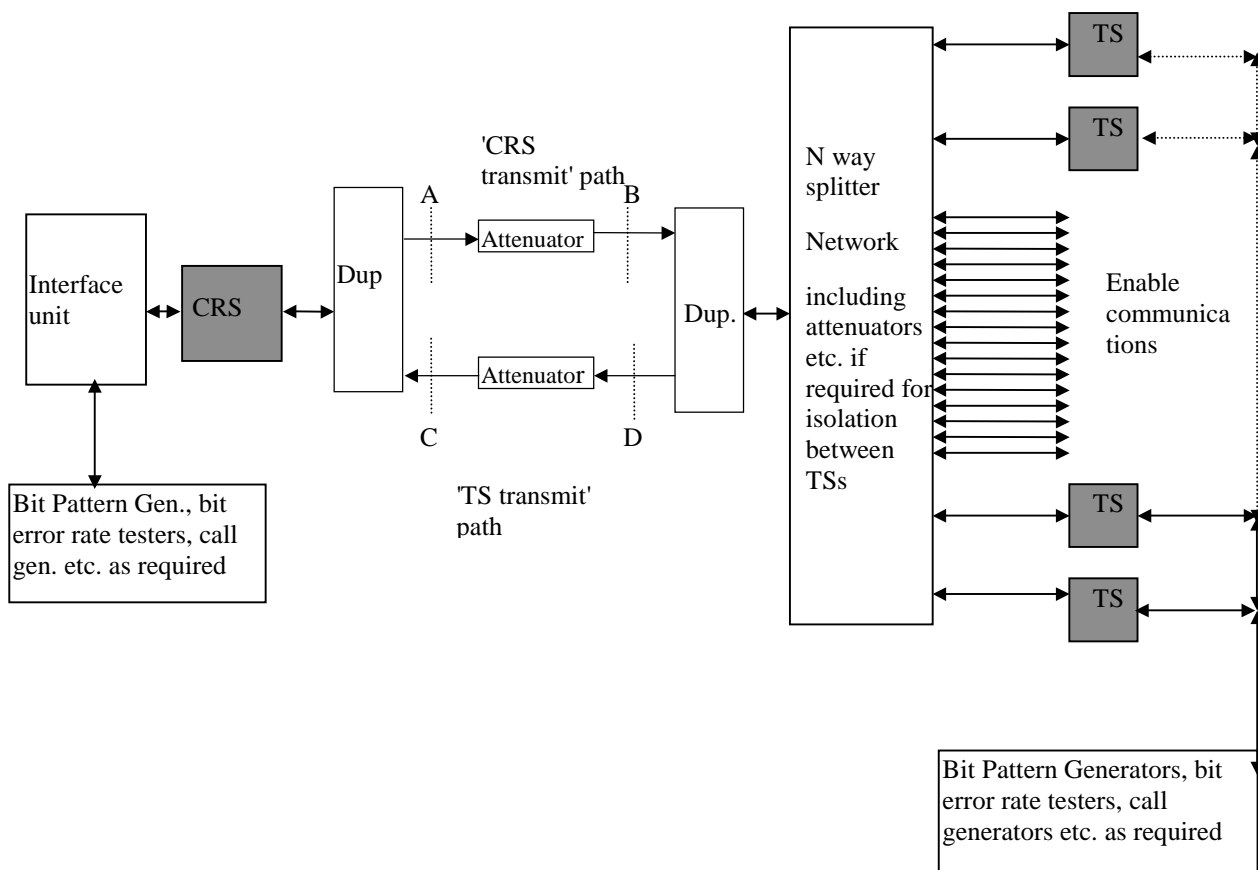

Figure 4: Test configuration for multiple Terminal Stations

## 4.2 Transmitter characteristics

### 4.2.1 Maximum RF output power

Objective:

Verify that the highest average RF output power measured during a transmission burst at reference point B' or C' (see figure 5) is within the supplier's declared value, plus/minus the EN/ETS tolerance, and does not exceed the EN/ETS (where not specified then the ITU/CEPT) maximum value.

Test instruments:

Average Power Meter with a time gating function or an appropriate alternate (including theoretical calculation to correct a normal power meter reading).

Test Configuration:

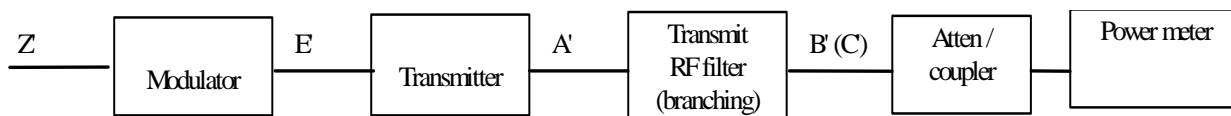

**Figure 5: Test configuration for maximum RF output power**

Test Procedure:

With the transmitter power level set to maximum, including ATPC/RTPC, etc, the maximum output power of the transmitter at point B' (C) during the worst case, as declared by the supplier, of the modulated transmission burst is measured. To make this measurement an average power meter with a time gating function or an appropriate alternate shall be used. All systems should be tested at 3 frequencies: top, middle and bottom frequencies of the available range. A power splitter or coupler may be required if the TS requires an RF link from the CRS before it can operate. For the CRS this may be done using a power meter with all sub carriers and all time slots transmitting at maximum power. For the TS this may be done by synchronizing the power measurement with the active burst(s) or correcting the power with a correction due to the on/off duty cycle. The TS power also needs to be corrected for the TS sub channel bandwidth against the Channel (CRS) bandwidth. This correction shall be stated in the report.

## 4.2.2 Minimum RF output power (if applicable)

Objective:

Verify that the minimum RF output power measured at reference point B' or C' of equipment which is fitted with a power control facility is within the specified limit of the declared value.

Test Instruments:

As for the maximum power test.

Test Configuration:

As for the maximum power test.

Test Procedure:

With the transmitter power level set to minimum the transmitter output at B' (C) is to be measured. All systems should be tested at 3 frequencies: top, middle and bottom frequencies of the available range.

## 4.2.3 Automatic Transmit Power Control (ATPC)

**NOTE:** ATPC is typically an optional feature. However, when fitted and/or required by the standard, the minimum and maximum output power levels must be checked. In addition, satisfactory operation of the automatic facility must be demonstrated.

Objective:

When ATPC is implemented, the control loop is to be checked for satisfactory operation i.e.: Tx output power is related to the input level at the far end receiver.

Test Instruments:

As for maximum power test.

Test Configuration:

To be declared by the supplier.

Test Procedure:

Throughout the transmitter's selected power range, the receiver input level is to be maintained within the limits stated in the relevant EN/ETS or in supplier's guaranteed operating criteria. The test is to be repeated to verify that the automatic power control performance, between maximum selected transmitter power and minimum transmitter power meets the EN/ETS or supplier's performance limits.

#### 4.2.4 Remote Transmit Power Control (RTPC)

Where remote transmit power control option is fitted, it may be checked and recorded during the transmitter output power test. The maximum power shall not exceed that applied in clause 4.2.1 as an essential requirement.

#### 4.2.5 Frequency accuracy

Objective:

To verify that the Tx output frequency is within the limits specified in the relevant EN/ETS.

NOTE 1: For systems that do not shut down on loss of synchronization, the frequency accuracy should also be measured in the non-synchronized condition.

Test Instruments:

- 1) Frequency Counter capable of measuring modulated signals.
- 2) Spectrum Analyser with an accurate frequency reference (recommended two orders of magnitude greater than the allowed limit), internal or external.

Test Configuration:

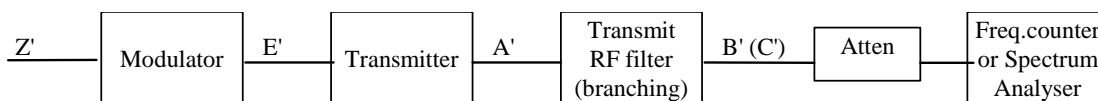

**Figure 6: Test configuration for frequency accuracy**

Test Procedure:

The Tx is to be operated in the normal operating modulated condition (or CW condition if available) and frequency measurements conducted on each of the three selected frequencies (top, middle and bottom) through the remote frequency control, if fitted. The measured frequency is to be within the supplier's stated operating range. A power splitter or coupler may be required if the TS requires an RF link from the CRS before it can operate.

Using appropriately gated frequency counter or a spectrum analyser, the carrier breakthrough or the CW signal shall be measured.

If adequate measurement stability or accuracy cannot be achieved by this method, then the supplier shall make available an appropriate method to place the transmitter in a mode that allows the frequency of the carrier or a pair of sidebands to be measured. This method shall be recorded in the report.

NOTE 2: For systems that do not shut down on loss of synchronization, frequency accuracy should also be measured in the non-synchronized condition.

NOTE 3: Where the number of sub channels do not allow the measurement of the "centre" frequency, then the measurement shall declare the separation frequency from the ITU channel centre frequency of the sub channel under test.

## 4.2.6 RF spectrum mask

RF spectrum mask measurements are to be conducted at the top, middle and bottom channel of the unit under test.

Objective:

To verify that the output spectrum is within the specified limits of the relevant EN/ETS.

Test Instruments:

- 1) Spectrum Analyser.
- 2) Plotter or other storage media.

Test Configuration:



**Figure 7: Test configuration for Spectrum Mask**

Test Procedure:

The transmitter output port shall be connected to either a Spectrum Analyser via an attenuator or an artificial load with some means of monitoring the emissions with a Spectrum Analyser. The Spectrum Analyser shall have a variable persistence display or a digital storage facility. When not stated in the relevant EN/ETS, the resolution bandwidth, frequency span, scan time and video filter settings of the Spectrum Analyser are to be set in accordance with the following indications. A power splitter or coupler may be required if the TS requires an RF link from the CRS before it can operate. For the CRS the tests shall show that when all sub channels are simultaneously transmitting, at full power, that the spectrum mask is met for the declared channel. For the TS the spectrum mask shall be tested by adding the individual sub carriers (using maximum hold function of the spectrum Analyser) against the spectrum mask until the full channel is met.

**Table 1: Spectrum Analyser Settings for RF Power Spectrum Measurement for CRS only (where not defined in the EN/ETS)**

RF channel spacing (MHz)	< 1,75	1,75 to 20	> 20
Centre frequency	actual	actual	actual
Sweep width (MHz)	see note 1	see note 1	see note 1
Scan time	auto	auto	auto
IF bandwidth (kHz)	30	30	100
Video bandwidth (kHz)	0,1	0,3	0,3

See note 2 for TS settings (where not defined in the EN/ETS).

NOTE 1:  $5 \times \text{channel spacing} < \text{sweep width} < 7 \times \text{channel spacing}$ .

NOTE 2: The spectrum analyser settings for RF power Spectrum Measurement for TDMA Terminal Stations (TS) are depending on the burst duration. For a burst duration of  $\approx 50 \mu\text{s}$ , the recommended settings are IF bandwidth  $\approx 30 \text{ kHz}$  and video bandwidth  $\approx 10 \text{ kHz}$ .

For other pulse durations, the recommended settings are as following:

- IF bandwidth  $\approx 30 \text{ kHz} \times 50 \mu\text{s}/(\text{pulse duration in } \mu\text{s})$ .
- Video bandwidth  $\approx 10 \text{ kHz} \times 50 \mu\text{s}/(\text{pulse duration in } \mu\text{s})$ .

The supplier has to declare the settings.

With the transmitter modulated by a signal having the characteristics given in the relevant EN/ETS, the transmitter power density (including the spectral lines at the symbol rate if stated in the EN/ETS), shall be measured by the Spectrum Analyser and recorded. Where possible, transmitter spectral power density plots at the top, middle and bottom frequencies of the supplier's declared operating range, are to be recorded.

## 4.2.7 Remote frequency control

Remote frequency control is an optional feature. However, when fitted the function must be tested during the frequency accuracy test. If necessary, repeat test as in clause 4.2.5 with frequency settings controlled using the remote frequency control option.

## 4.2.8 Spectral lines at the symbol rate

The test for spectral lines at the symbol rate is performed at the same time as the RF spectrum mask, see clause 4.2.6 if applicable to the standard.

## 4.2.9 Spurious emissions (external)

Objective:

To verify that any spurious emissions generated by the transmitter (including the spectral lines at the symbol rate if stated in the EN/ETS), are within the limits quoted in the relevant EN/ETS. Spurious emissions are emissions outside the bandwidth necessary to transfer the input data at the transmitter to the receiver of which level may be reduced without affecting the corresponding transfer of information. Spurious emissions include harmonic emissions, parasitic emissions, intermodulation products and frequency conversion products.

Test Instruments:

- 1) Spectrum Analyser.
- 2) Spectrum Analyser Mixer Units - as required.
- 3) Plotter or other storage media.

Test Configuration:

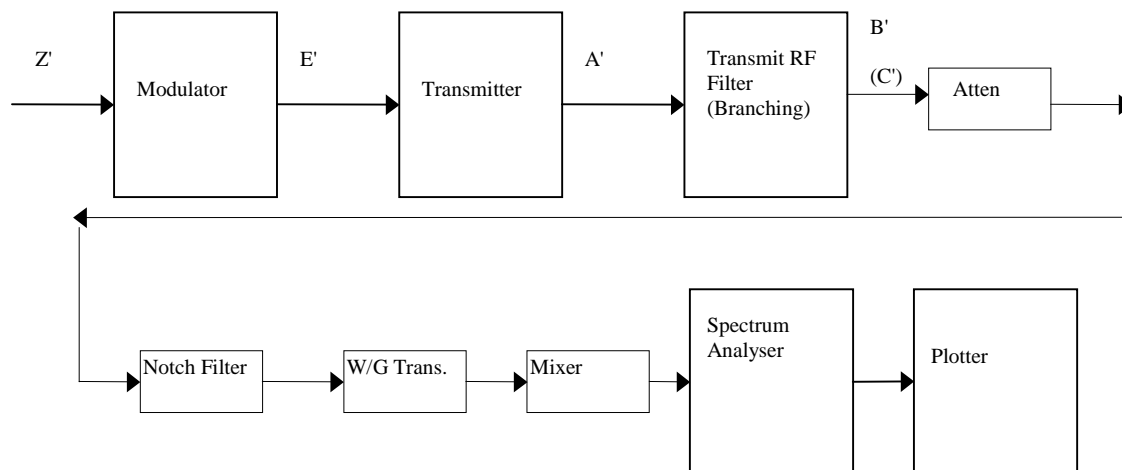

**Figure 8: Test configuration for conducted antenna port spurious emissions**

Test Procedure:

The transmitter output port shall be connected to either a Spectrum Analyser via a suitable attenuator and/or notch filter to limit the power into the front end of the Analyser. In some cases, where the upper frequency limit exceeds the basic operating range of the Analyser, suitable wave guide transitions and mixer will be required. It is important that the circuit between the transmitter and the input to the mixer, or Spectrum Analyser, is characterized over the frequency range to be measured. These losses should be used to set the limit line of the Analyser to a value which ensures that the specification criteria at point C' (see figure 9) is not exceeded.

The transmitter is to be operated at the supplier's maximum rated output power and the level and frequency of all significant signals are to be measured and plotted throughout the frequency band quoted in the relevant specification. It is recommended that each scan be taken in 5 GHz steps below 21,2 GHz and 10 GHz steps above 21,2 GHz. However, spurious emissions close to the limit should be plotted over a restricted range which clearly demonstrates that the signal does not exceed the relevant limit.

NOTE 1: When testing the TS; for measurements below the "carrier" frequency the TS shall be transmitting on the lowest sub channel within the channel under test. For measurements above the "carrier" frequency the TS shall be transmitting on the highest sub channel within the channel under test.

NOTE 2: Where a specification states that the spurious emission test is to be conducted with the equipment in the modulated condition, the resolution bandwidth of the Spectrum Analyser is to be set to the level quoted in the specification. The frequency span and scan rate of the Analyser should be adjusted to maintain the noise floor below the limit line and maintain the Spectrum Analyser in the calibrated condition.

NOTE 3: Measurement of spurious emission levels from equipment operating in the CW condition can be conducted with resolution bandwidth, frequency span and scan rates which maintain the Spectrum Analyser in the calibrated condition while keeping the difference between noise floor and limit line at least 10 dB.

NOTE 4: Due to the low levels of RF signal and the wide band modulation used in this type of equipment, radiated RF power measurements are imprecise compared to conducted measurements. Therefore where equipment is normally fitted with an integral antenna, the supplier shall supply a documented test fixture that converts the radiated signal into a conducted signal into a 50  $\Omega$  termination.

NOTE 5: The RF conducted signal shall be measured into a 50  $\Omega$  coaxial line to the spectrum analyser for all frequencies below the operating frequency if below 26,5 GHz. This is to prevent any external wave guide acting as a high pass filter.

Where the equipment standard refers to CEPT/ERC/REC 74-01E [5], the measurements are taken for the mean power of the spurious emissions during the transmission burst. For spurious emission measurements on the TS it may not be possible to complete a Spectrum Analyser frequency scan during a synchronized pulse (i.e. when the sweep time of the spectrum analyser is greater than the pulse time of the TS). In this case it shall be deemed that if the peak power over a statistically sufficient number of spectrum analyser sweeps is below the mean power limit, that the mean power limit is met. If this cannot be shown, then alternatives may be used as long as they detail the rationale behind the measurements in the report.

Measurements shall be made in accordance to the Published standard. Any variations shall be detailed and agreed with each National Regulator.

## 4.3 Receiver characteristics

### 4.3.1 Input level range (if applicable)

Objective:

To verify that the receiver meets the BER criteria, given in the relevant specification, over a defined range of receiver input levels.

Test Instruments:

See test procedure for BER versus Receiver input level (see clause 4.3.3.2).

Test Configuration:

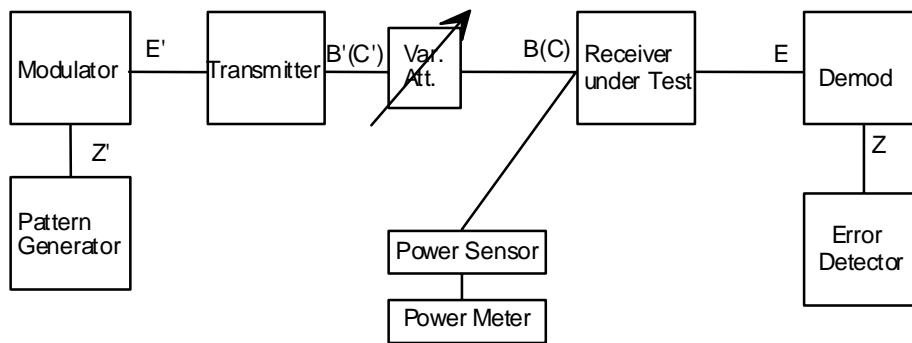

**Figure 9: Test configuration for input level range**

Test Procedure:

Connect the pattern generator output to the BB transmitter input Z' and the error detector to the BB Rx output Z. Switch the transmitter to standby and adjust the variable attenuator to provide maximum attenuation. Disconnect the receiver under test. Connect the power meter, through a suitable power sensor, to point B (C) (see figure 11). Switch on the transmitter and adjust the attenuator to set the power to the upper limit for the input level range test. Switch the transmitter to standby and reconnect the receiver under test.

The input level to the Rx shall be set to the upper and lower levels specified in the relevant ETS/EN or declared by the manufacturer, whichever is the greater and the BER at those RSLs recorded. If required increase the level of attenuation until the signal input level at the receiver causes BER equal to the limit quoted in the relevant specification and calculate the signal level i.e. upper receiver input level minus increase in attenuation. The receiver input level range is the signal range between the upper and lower receiver input levels.

NOTE 1: When the base band interface precludes the use of a Bit Error Ratio detector, e.g. in a packet data system, another measure of error performance may be specified by the supplier provided that its numerical equivalence to the BER test can be shown. This proof of equivalence should be recorded in the report.

NOTE 2: The RSL shall be that of the channel in the Standard. If testing sub channels, then the RSL figure shall be corrected to either allow for the change in channel size, or shall be tested with all sub carriers active. These details shall be recorded in the report, with a sample calculation if needed.

## 4.3.2 Spurious emissions

The same test method as described in clause 4.2.9 is applicable. Spurious emission levels from a transmitter and receiver of duplex equipment using a common port are measured simultaneously and the test only needs to be conducted once.

Objective:

To verify that spurious emissions from the receiver are within the limits.

## 4.4 System characteristics

### 4.4.1 Dynamic level range

Objective:

To verify that the system, with ATPC operating (where applicable) meets the BER criteria, given in the relevant specification, over a defined range of input levels.

Test Instruments:

- 1) Power Sensor and Meter.
- 2) Pattern Generator/Error Detector.

Test Configuration:

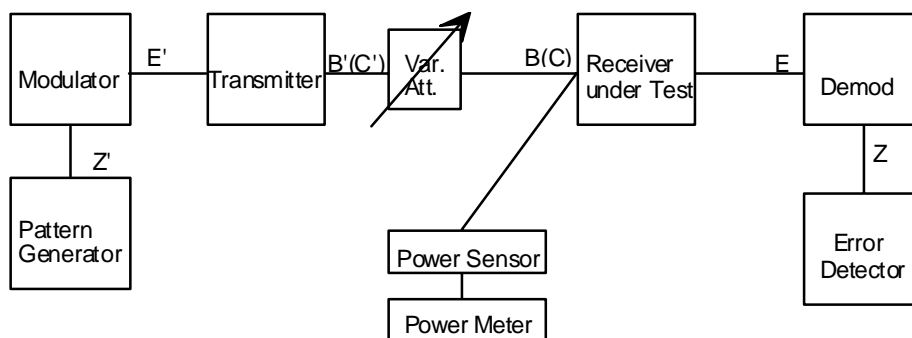

**Figure 10: Test configuration for dynamic level range**

Test Procedure:

Connect the pattern generator output to the BB transmitter input  $Z'$  and the error detector to the BB Rx output  $Z$ . Switch the transmitter to standby and adjust the variable attenuator to provide maximum attenuation. Disconnect the receiver under test. Connect the power meter, through a suitable power sensor, to point B (C) (see figure 12). Switch on the transmitter and adjust the attenuator to set the power to the upper limit for the test of the input level range until the signal input level at the receiver causes a BER equal to the limit quoted in the relevant specification. Switch the transmitter to standby and reconnect the receiver under test.

Increase the level of attenuation until the signal input level at the receiver causes a BER equal to the lower limit quoted in the relevant specification and calculate the signal level i.e. upper receiver input level minus increase in attenuation. The receiver input level range is the signal range between the upper and lower receiver input levels.

The dynamic input level range is calculated by the measured input level range between the upper and the lower receiver input level referred to a specified BER (any built-in attenuator in the signal path is to be taken into account) increased by the declared and measured control range of an ATPC or a RTPC (see clauses 4.2.3 and 4.2.4).

**NOTE:** The RSL shall be that of the channel specified in the Standard. If testing sub channels, then the RSL figure shall be tested with all sub carriers active (recommended), or shall be corrected to either allow for the change in channel size. These details shall be recorded in the report, with a sample calculation if needed.

#### 4.4.2 BER as a function of receiver input signal level RSL

Objective:

To verify that the received signal levels versus BER thresholds are within the limits specified, (at a minimum of two BER levels), in the relevant EN/ETS.

Test Instruments:

- 1) Pattern Generator/Error Detector.
- 2) Power Sensor and Meter.



Test Configuration:

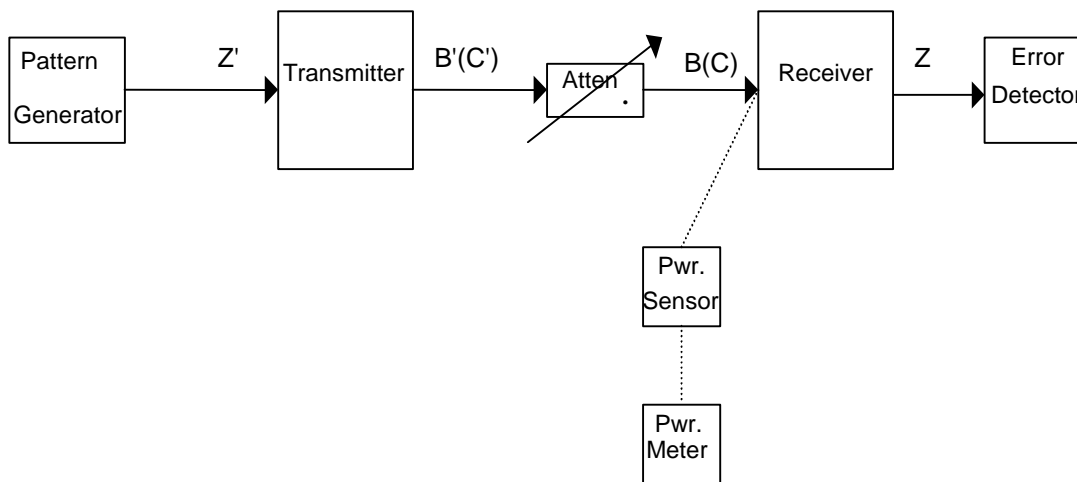

**Figure 11: Test configuration for BER as a function of RSL**

Test Procedure:

Connect the pattern generator output to the BB input of the transmitter. Send the BB output signal of the Rx to the Error Detector. Then take record of BER curve by varying the received level. Verify that the RSL, corresponding to the BER thresholds are within the specifications.

**NOTE:** The RSL shall be that of the channel in the Standard. If testing sub channels, then the RSL figure shall be corrected to either allow for the change in channel size, or shall be tested with all sub carriers active. These details shall be recorded in the report, with a sample calculation if needed.

### 4.4.3 Equipment Background BER

Objective:

To verify that the equipment background BER is below the value specified in the relevant EN/ETS.

Test Instruments:

- 1) Pattern Generator/Error Detector.
- 2) Power Meter.

Test Configuration:

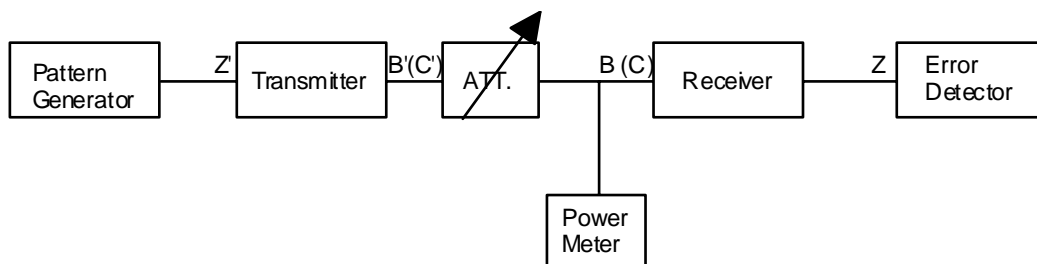

**Figure 12: Test configuration for background BER**

Test Procedure:

Initially connect the power meter to point B (C) and measure the output power of the transmitter at a level within the calibrated range of the power meter. Increase the attenuator setting to give the RF level specified in the EN/ETS. With the transmitter switched to standby, disconnect the power meter from the attenuator and connect the receiver to point B (C). Turn the transmitter RF output back on and record the BER.

NOTE: The RSL shall be that of the channel in the Standard. If testing sub channels, then the RSL figure shall be corrected to either allow for the change in channel size, or shall be tested with all sub carriers active. These details shall be recorded in the report, with a sample calculation if needed.

#### 4.4.4 Interference sensitivity

The following test procedures shall be used for measuring the interference sensitivities in both the CRS to TS and the TS to CRS directions.

##### 4.4.4.1 Co-channel interference sensitivity

The Supplier or the Test House should apply Method 1 or Method 2 as appropriate to the relevant equipment EN/ETS.

###### Method 1:

Objectives:

To verify that the BER at point Z, of the receiver under test, remains below the relevant specification limit in the presence of an interfering like modulated signal on the same channel. The signal levels of the wanted and interfering signals at point B (C) must be set at the levels given in the relevant specification.

Test Instruments:

- 1) 2 Bit Pattern Generators.
- 2) Error Detector.
- 3) Power Sensor and meter.

Test Configuration 1:

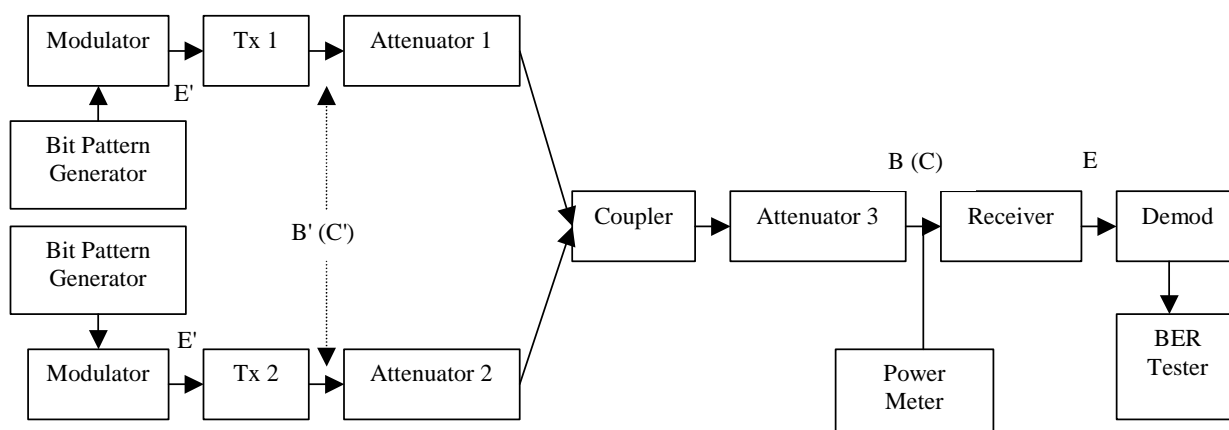

Figure 13: Test configuration for co-channel interference sensitivity - external

This test is to be carried out on a channel around the middle of the RF range.

Test Procedure for Method 1:

During this test both transmitters shall transmit on the same frequency and be modulated with different signals having the same characteristics. Switch the transmitters to standby and disconnect the wave guide or cable at point B (C) (see figure 13). Connect a suitable power sensor and meter. Switch on Tx 1 and adjust attenuator 1 to set the signal to a convenient level within the receiver input level range which will be the reference level. Switch Tx 1 to standby and Tx 2 on. Adjust attenuator 2 to set the interfering signal to a level below the reference level, measured previously, which is defined by the Carrier to Interfer (C/I) ratio given in the specification. Switch Tx 2 to standby.

Reconnect the receiver under test, switch on Tx 1 and increase attenuator 1 until the BER required by the EN/ETS is achieved. Increase attenuator 2 by the same amount attenuator 1 was increased, switch on Tx 2 and record the BER.

NOTE 1: It is also acceptable to use an additional attenuator between the coupler and receiver (point B (C)) to control the absolute wanted and unwanted signal levels into the receiver. The function of attenuators 1 and 2 is to maintain the correct Carrier to Interference ratio.

### Method 2:

Objective:

To verify that the maximum C/I value for 1 dB and 3 dB degradation on  $10^{-6}$  and  $10^{-3}$  BER remains below the relevant specification limit in presence of an interfering like modulated signal on the same channel.

Test Instruments:

- 1) 2 Pattern Generator.
- 2) Error Detector.
- 3) Power Sensor and Meter.

Test Configuration 2:

See figure 13.

This test is to be carried out on a channel around the middle of the RF range.

Test Procedure for Method 2:

During this test both transmitters shall transmit on the same channel and be modulated with signals that have the same characteristics. With the transmitters switched to standby set both attenuators to their maximum values.

Connect power meter at point B (C). Switch on Tx 1 and adjust attenuator 1 to set the wanted signal to the level required by the EN/ETS for  $10^{-6}$  (or  $10^{-3}$ ). Decrease attenuator 1 by 1 dB (or 3 dB) and record its setting. Switch on the interferer (or unwanted signal) and reduce attenuator 2 to achieve a BER of  $10^{-6}$  (or  $10^{-3}$ ) on the error detector. Switch both transmitters off and connect the wave guide, or cable, at point B (C). Record the setting of attenuator 2 and connect the power sensor and meter to the wave guide or cable.

If the level of the wanted signal has not previously being recorded, switch Tx 1 on and reduce attenuator 1 to produce a wanted signal level within the calibrated range of the power meter. Record the power level and reduction in attenuation. Calculate Power<sub>wanted signal</sub> = Measured power level minus change in attenuation. Switch off Tx. 1, switch on Tx. 2 and repeat the procedure to calculate the Power<sub>unwanted signal</sub>.

The maximum co-channel C/I value for 1 dB or 3 dB degradation on  $10^{-6}$  or  $10^{-3}$  is:

$$C/I = \text{Power}_{\text{wanted signal}} / \text{Power}_{\text{unwanted signal}}$$

NOTE 2: The RSL shall be that of the channel in the Standard. If testing sub channels, then the RSL figure shall be corrected to either allow for the change in channel size, or shall be tested with all sub carriers active. These details shall be recorded in the report, with a sample calculation if needed. The interferer shall be on the same sub channel as the link under test.

#### 4.4.4.2 Adjacent RF-channel interference sensitivity

The Supplier or the Test House should apply Method 1 or Method 2 as appropriate to the relevant equipment EN/ETS.

**For measurement details follow the Method 1 or 2 whichever is applied to the appropriate product standard.**

##### **Method 1:**

Objective:

To verify that the BER at point Z, of the receiver under test, remains below the relevant specification limit in the presence of an interfering like modulated signal on the adjacent channel. The signal levels of the wanted and interfering signals at point B (C) must be set at the levels given in the relevant specification.

Test Instruments:

Same as co-channel test.

Test Configuration 1:

Same as co-channel test (see figure 13).

This test is to be carried out on a channel around the middle of the RF range.

Test Procedure for Method 1:

During this test the interfering transmitter shall be modulated with signals having the same characteristics as the modulating signal of the wanted transmission and be tuned to an adjacent channel. Switch the transmitters to standby and disconnect the wave guide or cable at point B (C). Connect a suitable power sensor and meter. Switch on Tx 1 and adjust attenuator 1 to set the wanted signal at an initial level that is convenient for measurement, for example -30 dBm. Switch Tx 1 to standby and Tx 2 on. Adjust attenuator 2 to set the interfering signal to a level above the reference signal, measured previously, which is equal to the Carrier to Interfer (C/I) ratio given in the specification. Switch Tx 2 to standby.

Reconnect the receiver under test and increase both attenuators by equal amounts which ensure that the wanted and unwanted signal levels into the receiver are at their correct values. Switch on and modulate both transmitters. Record the receiver BER.

Decrease attenuator 2 until the receiver BER equals the limit quoted in the specification. Calculate and record the Carrier to Interference ratio.

Repeat the test with the interfering transmitter tuned to the second adjacent channel.

NOTE 1: It is also acceptable to use an additional attenuator between the combiner and receiver to control the absolute wanted and unwanted signal levels into the receiver. The function of attenuators 1 and 2 is to maintain the correct Carrier to Interfere ratio.

NOTE 2: The RSL shall be that of the channel in the Standard. If testing sub channels, then the RSL figure shall be corrected to either allow for the change in channel size, or shall be tested with all sub carriers active. These details shall be recorded in the report, with a sample calculation if needed. Testing of the adjacent -1 channel shall be done with the link on the lowest sub channel within the wanted channel, and the interferer shall be on the highest sub channel of the adjacent -1 channel. Testing of the adjacent +1 channel shall be done with the link on the highest sub channel within the wanted channel, and the interferer shall be on the lowest sub channel of the adjacent +1 channel.

##### **Method 2:**

Objective:

To verify that the maximum C/I value [for 1 dB and 3 dB degradation on  $10^{-6}$  and  $10^{-3}$  BER] remains below the relevant specification limit in the presence of an interfering like modulated signal on the adjacent channel.

Test Instruments:

- 1) 2 Pattern Generator.
- 2) Error Detector.
- 3) Power Sensor and Meter.

Test Configuration:

Same as co-channel test (see figure 13).

This test is to be carried out on a channel around the middle of the RF range.

Test Procedure for Method 2:

During this test the interferer (or unwanted signal, Tx. 2) shall transmit on one of the adjacent channels and be modulated with a signal having the same characteristics as the signal modulating the wanted transmitter. With both transmitters on standby set the attenuators to their maximum values.

Connect power meter at point B (C). Switch on Tx 1 and adjust attenuator 1 to set the wanted signal to the level required by the ETS for  $10^{-6}$  (or  $10^{-3}$ ). Decrease attenuator 1 by 1 dB (or 3 dB) and record its setting. Switch on the interferer or unwanted signal and reduce attenuator 2 to achieve a BER of  $10^{-6}$  (or  $10^{-3}$ ) on the error detector. Switch both transmitters off and disconnect the wave guide, or cable, at point B (C). Record the setting of attenuator 2 and connect the power sensor and meter to the wave guide or cable.

Switch Tx. 1 on and reduce attenuator 1 to produce a wanted signal level within the calibrated range of the power meter. Record the power level and reduction in attenuation. Calculate  $\text{Power}_{\text{wanted signal}} = \text{Measured power level} - \text{change in attenuation}$ . Switch off Tx. 1, switch on Tx. 2 and repeat the procedure to calculate the  $\text{Power}_{\text{unwanted signal}}$ .

The maximum co-channel C/I value for 1 dB or 3 dB degradation on  $10^{-6}$  or  $10^{-3}$  is:

$$C/I = \text{Power}_{\text{wanted signal}} / \text{Power}_{\text{unwanted signal}}$$

Repeat the test with the interferer on the second adjacent channel.

NOTE 3: The RSL shall be that of the channel in the Standard. If testing sub channels, then the RSL figure shall be corrected to either allow for the change in channel size, or shall be tested with all sub carriers active. These details shall be recorded in the report, with a sample calculation if needed. Testing of the adjacent -1 channel shall be done with the link on the lowest subchannel within the wanted channel, and the interferer shall be on the highest sub channel of the adjacent -1 channel. Testing of the adjacent +1 channel shall be done with the link on the highest subchannel within the wanted channel, and the interferer shall be on the lowest sub channel of the adjacent +1 channel.

#### 4.4.4.3 CW spurious interference

Objective:

This test is designed to identify specific frequencies at which the receiver may have a spurious response e.g. image frequency, harmonic response of the receive filter etc. The frequency range of the test should be in accordance with the relevant specification.

Test Instruments:

- 1) Pattern Generator.
- 2) Error Detector.
- 3) Signal Generator.
- 4) Power Sensor and Meter.

Test Configuration:

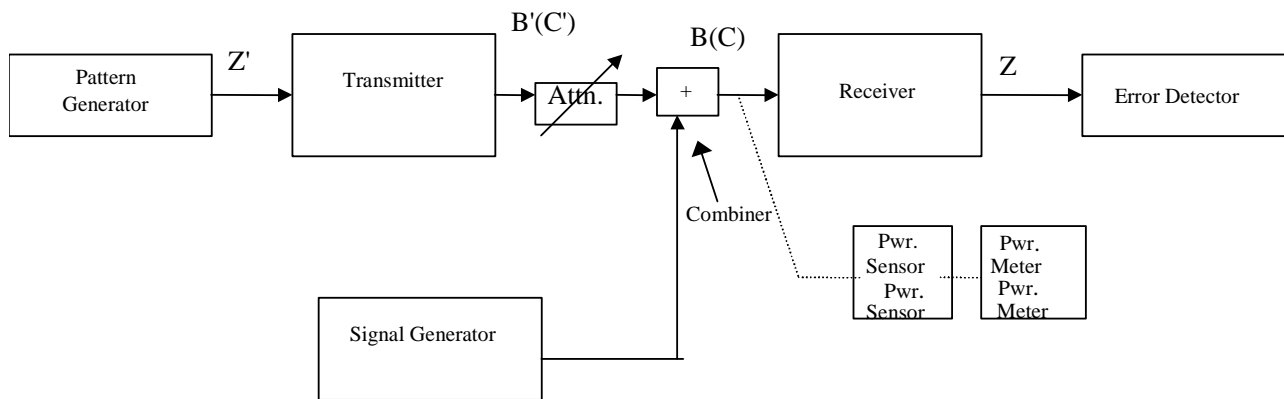

**Figure 14: Test configuration for CW spurious interference**

Test Procedure:

With the signal generator output turned off, measure the transmitter RF output power at point B (C) using a suitable power sensor or spectrum analyser, with a known level of attenuation. Replace the power sensor/spectrum analyser with the receiver under test, and increase the level of attenuation until the BER threshold stated in the EN/ETS is measured. Calculate and record the receiver level (dBm) for this BER.

Across the frequency band required by the EN/ETS, measure and record the signal generator output power required to produce a level  $x$  dB above the BER threshold level stated in the EN/ETS;  $x$  is the required increase in level for the interfering signal and is also stated in the EN/ETS.

Disconnect the power sensor from point B (C) and connect the receiver under test. Confirm the BER level has not changed. Sweep the signal generator through the required frequency range at the output level determined above, taking into account any exclusion band stated in the EN/ETS.

Any frequencies which cause the BER to exceed the level stated in the EN/ETS shall be recorded. It is recommended that the calibration be rechecked at these frequencies.

- NOTE 1: The use of a stepped signal generator is permitted provided that the frequency step size is not greater than one third of the channel bandwidth of the receiver under test.
- NOTE 2: This test may require the use of low pass filters on the output of the signal generator to prevent harmonics of the signal generator falling into the receiver exclusion band.
- NOTE 3: If the total sweep time makes the test very time consuming (in excess of 4 hours), it may be acceptable to calibrate the level of the CW spurious interfere at  $x + 3$  dB and look for an increased maximum BER (e.g.  $10^{-3}$  instead of  $10^{-6}$ ). If the increased maximum BER limit is exceeded at any points then a slower sweep shall be performed across those frequency points with the CW interferer calibrated to  $x$  dB and the lower BER requirement. Either requirement may be met for any frequency point.
- NOTE 4: When testing the TS; for measurements below the "carrier" frequency the TS shall be receiving on the lowest sub channel within the channel under test. For measurements above the "carrier" frequency the TS shall be receiving on the highest sub channel within the channel under test.
- NOTE 5: The use of a spectrum analyser for the calibration has the advantage of speed (using a wide VBW/RBW and trace max. hold) at a loss of accuracy. In this case is it recommended to over test by a level equal to the measurement uncertainty of the spectrum analyser, and re-measure any failures using a power meter to confirm the test level.
- NOTE 6: The RSL shall be that of the channel in the Standard (i.e. the channel size of the overall CRS). If testing sub channels, then the RSL figure shall be corrected to either allow for the change in channel size, or shall be tested with all sub carriers active. These Details shall be recorded in the report, with a sample calculation if needed. Testing shall be done on the lowest sub carrier at frequencies below the declared channel, and on the highest sub channel at frequencies above the declared channel.

---

## History

<b>Document history</b>			
V1.1.1	June 2001	Public Enquiry	PE 20011019: 2001-06-20 to 2001-10-19
V1.1.1	December 2001	Vote	V 20020201: 2001-12-03 to 2002-02-01