

ETSI EN 301 067-6 V1.1.3 (1999-11)

European Standard (Telecommunications series)

**Broadband Integrated Services Digital Network (B-ISDN);
Digital Subscriber Signalling System No. two (DSS2) protocol;
Connection characteristics;
Negotiation during call/connection establishment phase;
Part 6: Abstract Test Suite (ATS) and partial Protocol
Implementation eXtra Information for Testing (PIXIT)
proforma specification for the network**



Reference

DEN/SPS-05151-6 (9vpi0ie0.PDF)

Keywords

ATM, ATS, B-ISDN, broadband, DSS2, ISDN,
network, PIXIT, UNI

ETSI

Postal address

F-06921 Sophia Antipolis Cedex - FRANCE

Office address

650 Route des Lucioles - Sophia Antipolis
Valbonne - FRANCE
Tel.: +33 4 92 94 42 00 Fax: +33 4 93 65 47 16
Siret N° 348 623 562 00017 - NAF 742 C
Association à but non lucratif enregistrée à la
Sous-Préfecture de Grasse (06) N° 7803/88

Internet

secretariat@etsi.fr
Individual copies of this ETSI deliverable
can be downloaded from
<http://www.etsi.org>
If you find errors in the present document, send your
comment to: editor@etsi.fr

Important notice

This ETSI deliverable may be made available in more than one electronic version or in print. In any case of existing or perceived difference in contents between such versions, the reference version is the Portable Document Format (PDF). In case of dispute, the reference should be the printing on ETSI printers of the PDF version kept on a specific network drive within ETSI Secretariat.

Copyright Notification

No part may be reproduced except as authorized by written permission.
The copyright and the foregoing restriction extend to reproduction in all media.

© European Telecommunications Standards Institute 1999.
All rights reserved.

Contents

Intellectual Property Rights	5
Foreword	5
1 Scope	6
2 References	6
3 Definitions and abbreviations	7
3.1 Definitions	7
3.1.1 Definitions related to conformance testing	7
3.1.2 Definitions related to EN 301 067-1	7
3.2 Abbreviations	8
4 Abstract Test Method (ATM)	8
4.1 Conventions for test components and PCOs	9
5 Untestable test purposes	10
6 ATS to TP map	10
7 PCTR conformance	10
8 PIXIT conformance	11
9 ATS Conformance	11
Annex A (normative): Protocol Conformance Test Report (PCTR) proforma	12
A.1 Identification summary	12
A.1.1 Protocol conformance test report	12
A.1.2 IUT identification	12
A.1.3 Testing environment	12
A.1.4 Limits and reservations	12
A.1.5 Comments	13
A.2 IUT Conformance status	13
A.3 Static conformance summary	13
A.4 Dynamic conformance summary	14
A.5 Static conformance review report	14
A.6 Test campaign report	15
A.7 Observations	15
Annex B (normative): Partial PIXIT proforma	16
B.1 Identification summary	16
B.2 Abstract test suite summary	16
B.3 Test laboratory	16
B.4 Client (of the Test Laboratory)	17
B.5 SUT	17
B.6 Protocol information	18
B.6.1 Protocol identification	18
B.6.2 Configuration to be tested	18
B.6.3 Test management timers	18
B.6.4 Parameter Values	19

Annex C (normative):	Abstract Test Suite (ATS)	20
C.1	The TTCN Graphical form (TTCN.GR).....	20
C.1	The TTCN Machine Processable form (TTCN.MP)	20
	Bibliography	21
	History	22

Intellectual Property Rights

IPRs essential or potentially essential to the present document may have been declared to ETSI. The information pertaining to these essential IPRs, if any, is publicly available for **ETSI members and non-members**, and can be found in SR 000 314: "*Intellectual Property Rights (IPRs); Essential, or potentially Essential, IPRs notified to ETSI in respect of ETSI standards*", which is available from the ETSI Secretariat. Latest updates are available on the ETSI Web server (<http://www.etsi.org/ipr>).

Pursuant to the ETSI IPR Policy, no investigation, including IPR searches, has been carried out by ETSI. No guarantee can be given as to the existence of other IPRs not referenced in SR 000 314 (or the updates on the ETSI Web server) which are, or may be, or may become, essential to the present document.

Foreword

This European Standard (Telecommunications series) has been produced by ETSI Technical Committee Signalling Protocol and Switching (SPS).

The present document is part 6 of a multi-part EN covering the Broadband Integrated Services Digital Network (B-ISDN); Digital Subscriber Signalling System No. two (DSS2) protocol; Connection characteristics; Negotiation during call/connection establishment phase, as described below:

- Part 1: "Protocol specification [ITU-T Recommendation Q.2962 (1996), modified]";
- Part 2: "Protocol Implementation Conformance Statement (PICS) proforma specification";
- Part 3: "Test Suite Structure and Test Purposes (TSS&TP) specification for the user";
- Part 4: "Abstract Test Suite (ATS) and partial Protocol Implementation eXtra Information for Testing (PIXIT) proforma specification for the user";
- Part 5: "Test Suite Structure and Test Purposes (TSS&TP) specification for the network";
- Part 6: "Abstract Test Suite (ATS) and partial Protocol Implementation eXtra Information for Testing (PIXIT) proforma specification for the network".**

National transposition dates	
Date of adoption of this EN:	26 November 1999
Date of latest announcement of this EN (doa):	29 February 2000
Date of latest publication of new National Standard or endorsement of this EN (dop/e):	31 August 2000
Date of withdrawal of any conflicting National Standard (dow):	31 August 2000

1 Scope

The present document specifies the network Abstract Test Suite (ATS) for the T_B reference point or coincident S_B and T_B reference point (as defined in ITU-T Recommendation I.413 [12]) of implementations conforming to the standards for the signalling user-network layer 3 specification for Negotiation during call/connection establishment phase of the Digital Subscriber Signalling System No. two (DSS2) protocol for the pan-European Broadband Integrated Services Digital Network (B-ISDN), EN 301 067-1 [1].

A further part of the present document specifies the Test Suite Structure and Test Purposes (TSS&TP) related to this ATS and partial PIXIT proforma. Other parts specify the TSS&TP and the ATS and partial PIXIT proforma for the User side of the T_B reference point or coincident S_B and T_B reference point of implementations conforming to EN 301 067-1 [1].

2 References

The following documents contain provisions which, through reference in this text, constitute provisions of the present document.

- References are either specific (identified by date of publication, edition number, version number, etc.) or non-specific.
- For a specific reference, subsequent revisions do not apply.
- For a non-specific reference, the latest version applies.
- A non-specific reference to an ETS shall also be taken to refer to later versions published as an EN with the same number.

- [1] EN 301 067-1 (V1.1): "Broadband Integrated Services Digital Network (B-ISDN); Digital Subscriber Signalling System No. two (DSS2) protocol; Connection characteristics; Negotiation during call/connection establishment phase; Part 1: Protocol specification [ITU-T Recommendation Q.2962 (1996), modified]".
- [2] EN 301 067-2 (V1.1): "Broadband Integrated Services Digital Network (B-ISDN); Digital Subscriber Signalling System No. two (DSS2) protocol; Connection characteristics; Negotiation during call/connection establishment phase; Part 2: Protocol Implementation Conformance Statement (PICS) proforma specification".
- [3] EN 301 067-4 (V1.1): "Broadband Integrated Services Digital Network (B-ISDN); Digital Subscriber Signalling System No. two (DSS2) protocol; Connection characteristics; Negotiation during call/connection establishment phase; Part 4: Abstract Test Suite (ATS) and partial Protocol Implementation eXtra Information for Testing (PIXIT) proforma specification for the user".
- [4] EN 301 067-5 (V1.1): "Broadband Integrated Services Digital Network (B-ISDN); Digital Subscriber Signalling System No. two (DSS2) protocol; Connection characteristics; Negotiation during call/connection establishment phase; Part 5: Test Suite Structure and Test Purposes (TSS&TP) specification for the network".
- [5] EN 300 443-1: "Broadband Integrated Services Digital Network (B-ISDN); Digital Subscriber Signalling System No. two (DSS2) protocol; B-ISDN user-network interface layer 3 specification for basic call/bearer control; Part 1: Protocol specification [ITU-T Recommendation Q.2931 (1995), modified]".
- [6] EN 300 443-2: "Broadband Integrated Services Digital Network (B-ISDN); Digital Subscriber Signalling System No. two (DSS2) protocol; B-ISDN user-network interface layer 3 specification for basic call/bearer control; Part 2: Protocol Implementation Conformance Statement (PICS) proforma specification".
- [7] ISO/IEC 9646-1 (1994): "Information technology - Open Systems Interconnection - Conformance testing methodology and framework - Part 1: General concepts".

- [8] ISO/IEC 9646-2 (1994): "Information technology - Open Systems Interconnection - Conformance testing methodology and framework - Part 2: Abstract Test Suite specification".
- [9] ISO/IEC 9646-3 (1998): "Information technology - Open Systems Interconnection - Conformance testing methodology and framework - Part 3: The Tree and Tabular Combined Notation (TTCN)".
- [10] ISO/IEC 9646-4 (1994): "Information technology - Open Systems Interconnection - Conformance testing methodology and framework - Part 4: Test realization".
- [11] ISO/IEC 9646-5 (1994): "Information technology - Open Systems Interconnection - Conformance testing methodology and framework - Part 5: Requirements on test laboratories and clients for the conformance assessment process".
- [12] ITU-T Recommendation I.413 (1993): "B-ISDN user-network interface".

3 Definitions and abbreviations

3.1 Definitions

For the purposes of the present document, the following terms and definitions apply, in addition to those given in EN 301 067-1 [1] and EN 300 443-1 [5].

3.1.1 Definitions related to conformance testing

Abstract test case: Refer to ISO/IEC 9646-1 [7]

Abstract Test Method (ATM): Refer to ISO/IEC 9646-1 [7]

Abstract Test Suite (ATS): Refer to ISO/IEC 9646-1 [7]

Implementation Under Test (IUT): Refer to ISO/IEC 9646-1 [7]

System Under Test (SUT): See ISO/IEC 9646-1 [7]

Upper Tester (UT): See ISO/IEC 9646-1 [7]

Lower tester: Refer to ISO/IEC 9646-1 [7]

Protocol Implementation Conformance Statement (PICS): Refer to ISO/IEC 9646-1 [7]

PICS proforma: Refer to ISO/IEC 9646-1 [7]

Protocol Implementation eXtra Information for Testing (PIXIT): Refer to ISO/IEC 9646-1 [7]

PIXIT proforma: Refer to ISO/IEC 9646-1 [7]

Test Purpose (TP): Refer to ISO/IEC 9646-1 [7]

Point of Control and Observation (PCO): See ISO/IEC 9646-1 [7]

3.1.2 Definitions related to EN 301 067-1

user: DSS2 protocol entity at the User side of the user-network interface where a T_B reference point or coincident S_B and T_B reference point applies

user (S_B/T_B): DSS2 protocol entity at the User side of the user-network interface where a coincident S_B and T_B reference point applies

user (T_B): DSS2 protocol entity at the User side of the user-network interface where a T_B reference point applies (user is a private ISDN)

3.2 Abbreviations

For the purposes of the present document, the following abbreviations apply:

ATM	Abstract Test Method
ATS	Abstract Test Suite
B-ISDN	Broadband Integrated Services Digital Network
CM	Coordination Messages
DSS2	Digital Subscriber Signalling System No. two
ExTS	Executable Test Suite
IUT	Implementation Under Test
LT	Lower Tester
MOT	Means Of Testing
MTC	Main Test Component
PCO	Point of Control and Observation
PDU	Protocol Data Unit
PICS	Protocol Implementation Conformance Statement
PIXIT	Protocol Implementation eXtra Information for Testing
PTC	Parallel Test Components
SUT	System Under Test
TP	Test Purpose
TSS	Test Suite Structure
TTCN	Tree and Tabular Combined Notation
UT	Upper Tester
VCI	Virtual Channel Identifier
VPCI	Virtual Path Connection Identifier

4 Abstract Test Method (ATM)

The requirement for testing the network IUT is to focus on the behaviour of the network IUT at the user-network interface where a T_B reference point or coincident S_B and T_B reference point applies. Thus the IUT is the network DSS2 protocol entity at a particular user-network interface and is not the whole network.

It is possible to specify an ATS based on a Single party (remote) test method for such an IUT. However, it is considered that an ATS based on such an approach is of limited use as the only way to specify IUT generated PDUs is to use the "implicit send" statement. Many users of such an ATS would replace the "implicit send" statements with descriptions of the behaviour at other interfaces.

An ATS based on a multi-party test method is considered to be more useful in that it is closer to how a real test suite would be constructed. Such a test method specifies behaviour at multiple network interfaces. One very important limitation here is that tests are focussed on one particular interface. Thus the test system is made up one Main Test Component (MTC) and one or more Parallel Test Components (PTC), see figure 1.

4.1 Conventions for test components and PCOs

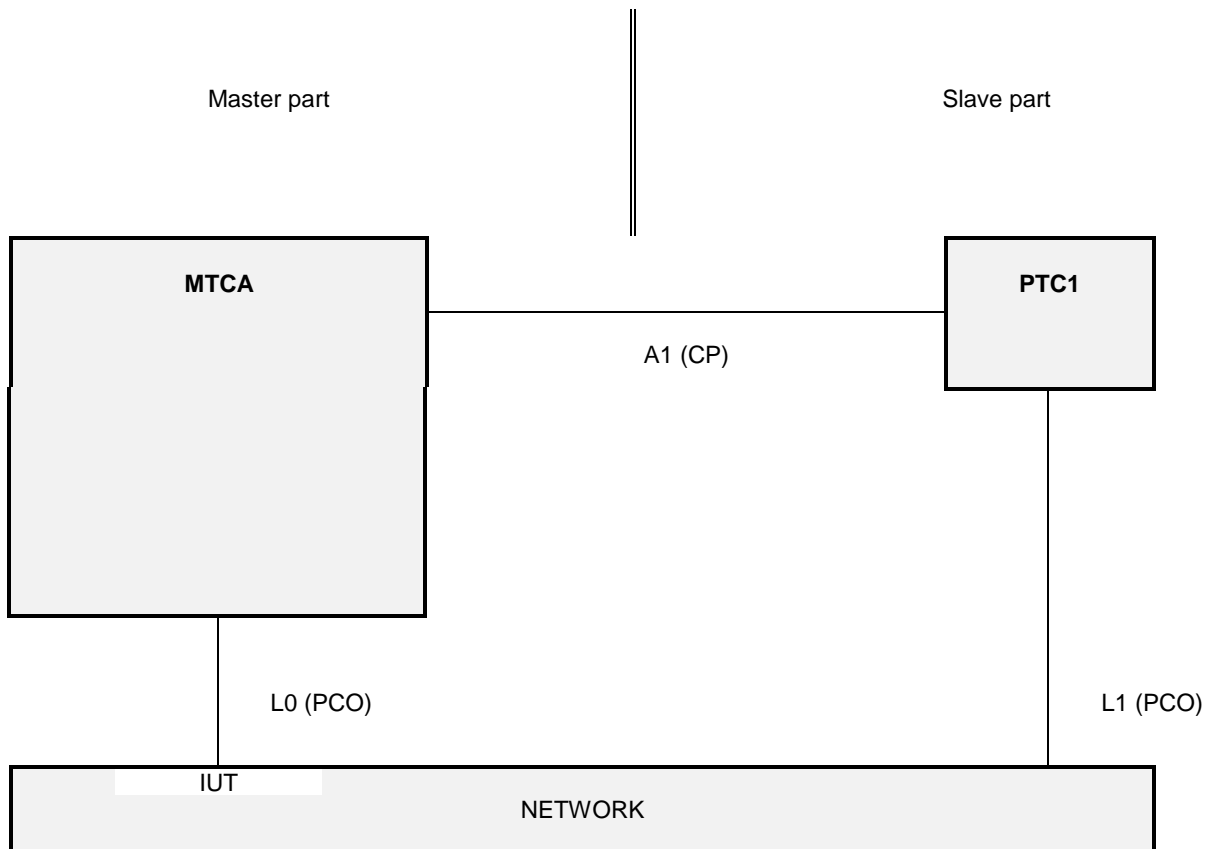

Figure 1: Multi-party test method

In a master/slave arrangement, the MTC is considered to be the master while the PTCs are the slaves. The "slave" testers are only an explicit description of how to deal with the remote interfaces during the testing process, i.e. "how to make the IUT send the required message".

This means, in particular, that the verdict will only be assigned from the protocol aspects observed on *the* interface under test (i.e. by the "master" tester), as it would be observed by a terminal connected to this interface. A failure in the correlation between the protocol at the different interfaces to which the different testers are connected, i.e. in the mechanism of the functional service itself, will not cause a FAIL verdict. For instance, if the IUT fails to send a message on the tested interface after another interface has received the proper stimulus, the verdict will be INCONCLUSIVE.

The MTC MTCA has two functions in this configuration. Firstly, it has the MTC function of controlling the one or more PTCs. Thus it is responsible for starting the PTCs and afterwards coordinates activities by exchanging Coordination Messages (CM) with the PTCs. Secondly it is responsible for the behaviour of the Lower Tester (LT) at PCO L0.

A combination of the remote and multi-party test methods is applied. As can be seen from figure 1, several PCOs are used. All PCOs reside at the service access points between layers 2 and 3.

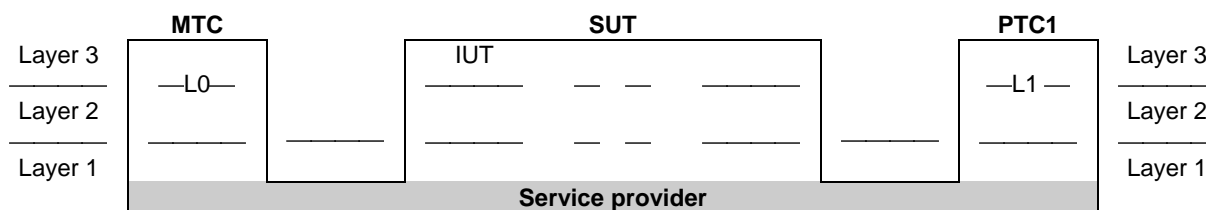

Figure 2: Combination of the remote and multi-party test methods

The MTC PCO is named "L0" ("L" for Lower). The L0 PCO is used to control and observe the behaviour of the IUT and test case verdicts are assigned depending on the behaviour observed at this PCO. The PTCs PTC1, PTC2 etc. use PCOs L1, L2 etc. These PCOs are used to control and, in a limited way, observe the behaviour of the network equipment at interfaces other than the one under test. No verdicts are assigned at these PCOs.

As stated in a previous paragraph, the non-receipt of network generated messages at L0, which are stimulated by events at the L1, L2 etc., will result in INCONCLUSIVE rather than FAIL verdicts being assigned.

PTC2 is only activated in that test cases that test the procedures at the access between a root user and the IUT, when more than one party is involved in the call between the root user and the IUT. In test cases which verify that the IUT rejects invalid or unacceptable SETUP messages, no PTC is activated at all, as these rejection procedures are considered local to the access between IUT and MTC.

5 Untestable test purposes

There are no untestable test purposes associated with this ATS.

6 ATS to TP map

The identifiers used for the TPs (see EN 301 067-5 [4]) are reused as test case names. Thus there is a straightforward one-to-one mapping.

7 PCTR conformance

A test laboratory, when requested by a client to produce a PCTR, is required, as specified in ISO/IEC 9646-5 [11], to produce a PCTR conformant with the PCTR template given in annex B of ISO/IEC 9646-5 [11].

Furthermore, a test laboratory, offering testing for the ATS specification contained in annex C, when requested by a client to produce a PCTR, is required to produce a PCTR conformant with the PCTR proforma contained in annex A of the present document.

A PCTR which conforms to this PCTR proforma specification shall preserve the content and ordering of the clauses contained in annex A. Clause A.6 of the PCTR may contain additional columns. If included, these shall be placed to the right of the existing columns. Text in italics may be retained by the test laboratory.

8 PIXIT conformance

A test realizer, producing an executable test suite for the Abstract Test Suite (ATS) specification contained in annex C, is required, as specified in ISO/IEC 9646-4 [10], to produce an augmented partial PIXIT proforma conformant with this partial PIXIT proforma specification.

An augmented partial PIXIT proforma which conforms to this partial PIXIT proforma specification shall, as a minimum, have contents which are technically equivalent to annex B. The augmented partial PIXIT proforma may contain additional questions that need to be answered in order to prepare the Means Of Testing (MOT) for a particular Implementation Under Test (IUT).

A test laboratory, offering testing for the ATS specification contained in Annex C, is required, as specified in ISO/IEC 9646-5 [11], to further augment the augmented partial PIXIT proforma to produce a PIXIT proforma conformant with this partial PIXIT proforma specification.

A PIXIT proforma which conforms to this partial PIXIT proforma specification shall, as a minimum, have contents which are technically equivalent to annex B. The PIXIT proforma may contain additional questions that need to be answered in order to prepare the test laboratory for a particular IUT.

9 ATS Conformance

The test realizer, producing a Means Of Testing (MOT) and Executable Test Suite (ExTS) for this Abstract Test Suite (ATS) specification, shall comply with the requirements of ISO/IEC 9646-4 [10]. In particular, these concern the realization of an Executable Test Suite (ExTS) based on each ATS. The test realizer shall provide a statement of conformance of the MOT to this ATS specification.

An ExTS which conforms to this ATS specification shall contain test groups and test cases which are technically equivalent to those contained in the ATS in annex C. All sequences of test events comprising an abstract test case shall be capable of being realized in the executable test case. Any further checking which the test system might be capable of performing is outside the scope of this ATS specification and shall not contribute to the verdict assignment for each test case.

Test laboratories running conformance test services using this ATS shall comply with ISO/IEC 9646-5 [11].

A test laboratory which claims to conform to this ATS specification shall use an MOT which conforms to this ATS.

Annex A (normative): Protocol Conformance Test Report (PCTR) proforma

Notwithstanding the provisions of the copyright clause related to the text of the present document, ETSI grants that users of the present document may freely reproduce the PCTR proforma in this annex so that it can be used for its intended purposes and may further publish the completed PCTR.

A.1 Identification summary

A.1.1 Protocol conformance test report

PCTR number:	
PCTR Date:	
Corresponding SCTR number:	
Corresponding SCTR date:	
Test Laboratory identification:	
Test Laboratory Manager:	
Signature:	

A.1.2 IUT identification

Name:	
Version:	
Protocol specification:	EN 301 067-1
PICS:	
Previous PCTRs (if any)	

A.1.3 Testing environment

PIXIT Reference number:	
ATS Specification:	EN 301 067-4
Abstract Test Method:	Multi-party test method (see ISO/IEC 9646-2)
Means of Testing identification:	
Dates of testing:	
Conformance Log reference(s):	
Retention Date for Log reference(s):	

A.1.4 Limits and reservations

Additional information relevant to the technical contents or further use of the test report, or to the rights and obligations of the test laboratory and the client, may be given here. Such information may include restriction on the publication of the report.

.....

.....

.....

.....

A.1.5 Comments

Additional comments may be given by either the client or the test laboratory on any of the contents of the PCTR, for example, to note disagreement between the two parties.

.....
.....
.....
.....

A.2 IUT Conformance status

This IUT has/has not been shown by conformance assessment to be non-conforming to the specified protocol specification.

Strike the appropriate words in this sentence. If the PICS for this IUT is consistent with the static conformance requirements (as specified in clause A.3 of this report) and there are no "FAIL" verdicts to be recorded (in clause A.6) strike the words "has or", otherwise strike the words "or has not".

A.3 Static conformance summary

The PICS for this IUT is/is not consistent with the static conformance requirements in the specified protocol.

Strike the appropriate words in this sentence.

A.4 Dynamic conformance summary

The test campaign did/did not reveal errors in the IUT.

Strike the appropriate words in this sentence. If there are no "FAIL" verdicts to be recorded (in clause A.6 of this report) strike the words "did or", otherwise strike the words "or did not".

Summary of the results of groups of tests:

.....
.....
.....
.....

A.5 Static conformance review report

If clause A.3 indicates non-conformance, this subclause itemizes the mismatches between the PICS and the static conformance requirements of the specified protocol specification.

.....
.....
.....
.....
.....
.....

A.6 Test campaign report

ATS Reference	Selected ? (Y/N)	Run ? (Y/N)	Verdict	Observations
Signalling procedures at the coincident S_B/T_B and at the T_B reference points				
NEGN_01_01				
NEGN_01_02				
NEGN_01_03				
NEGN_01_04				
NEGN_01_05				
NEGN_01_06				
NEGN_01_07				
NEGN_01_08				
NEGN_01_09				
NEGN_01_10				
NEGU_02_01				
NEGU_02_02				
NEGU_02_03				
NEGU_02_04				
NEGU_03_01				
NEGU_03_02				
NEGN_04_01				
NEGN_04_02				
NEGN_04_03				
NEGN_04_04				
NEGN_04_05				
NEGN_04_06				
NEGN_04_07				
NEGN_04_08				

A.7 Observations

Additional information relevant to the technical content of the PCTR are given here.

.....

.....

.....

.....

.....

.....

.....

.....

.....

.....

.....

.....

.....

.....

.....

.....

.....

.....

.....

.....

.....

.....

.....

.....

.....

.....

.....

Annex B (normative): Partial PIXIT proforma

Notwithstanding the provisions of the copyright clause related to the text of the present document, ETSI grants that users of the present document may freely reproduce the PIXIT proforma in this annex so that it can be used for its intended purposes and may further publish the completed PIXIT.

B.1 Identification summary

PIXIT Number:

.....

Test Laboratory Name:

.....

Date of Issue:

.....

Issued to:

.....

B.2 Abstract test suite summary

Protocol Specification: EN 301 067-1

ATS Specification: EN 301 067-6

Abstract Test Method: Multi-party test method (see ISO/IEC 9646-2)

B.3 Test laboratory

Test Laboratory Identification:

.....

Accreditation status of the test service:

.....

Accreditation reference:

.....

Test Laboratory Manager:

.....

Test Laboratory contact:

.....

Means of Testing:

.....

Test Laboratory instructions for Completion:

.....

B.4 Client (of the Test Laboratory)

Client Identification:

.....

Client Test manager:

.....

Client contact:

.....

Test Facilities required:

.....

B.5 SUT

Name:

.....

Version:

.....

SCS Reference:

.....

Machine configuration:

.....

Operating System Identification:

.....

IUT Identification:

.....

PICS (all layers):

.....

.....

Limitations of the SUT:

.....

Environmental Conditions:

.....

B.6 Protocol information

B.6.1 Protocol identification

Specification reference: EN 301 067-1

Protocol Version:

PICS Reference:

NOTE: The PICS Reference should reference a completed PICS which is conformant with the PICS proforma contained in ETS 300 443-2 and EN 301 067-2.

B.6.2 Configuration to be tested

Table B.1: Configuration to be tested

Item	Configuration Is the access to be tested...	Supported Y/N
1.1	releasing layer 2 after entering the Null link state U0?	

B.6.3 Test management timers

Table B.2: Timer values

Item	Timer Give a value for the timer that is used...	Value (in seconds)
3.1	as network side value for T310 (default value 10 seconds).	
3.2	to wait for the IUT to respond to a stimulus sent by the tester (TAC).	
3.3	to control that the IUT does not respond to a stimulus sent by the tester (TNOAC).	
3.4	to wait for the test operator to perform an implicit send action (TWAIT).	
NOTE: The IUT provider may fill in a value range rather than a fixed value for the test management timers. During test execution the test laboratory will choose specific values for the timers dependant on the means of testing used. These specific values may even be beyond the range given by the IUT provider, if this is necessary for achieving satisfactory test results.		

B.6.4 Parameter Values

Table B.3: Parameter values

Item	Parameter values Give...	Value
4.1	a coding of a Bearer capability information element, which the IUT is compatible with, for the purpose of accepting incoming calls.	
4.2	a coding of the Type of number and the Addressing/Numbering plan identification fields of the Called party number information elements to be sent to the IUT.	
4.3	a coding of the number digits of the access related to the PTC1.	
4.4	a coding of the number digits of a subscriber at the access related to the MTC.	
4.5	a coding of the ATM traffic descriptor (octet 5 onwards) to be sent to the IUT at call establishment.	
4.6	a coding of an incompatible ATM traffic descriptor (octet 5 onwards) to be sent to the IUT at call establishment.	
4.7	a coding of an Alternative ATM traffic descriptor (octet 5 onwards) to be sent to the IUT at call establishment.	
4.8	a coding of an incompatible Alternative ATM traffic descriptor (octet 5 onwards) to be sent to the IUT at call establishment.	
4.9	a coding of an Minimum acceptable ATM traffic descriptor (octet 5 onwards) to be sent to the IUT at call establishment.	
4.10	a coding of an incompatible Minimum acceptable ATM traffic descriptor (octet 5 onwards) to be sent to the IUT at call establishment.	
4.11	a value for the preferred VPCI.	
4.12	a value for the preferred VCI.	

Annex C (normative): Abstract Test Suite (ATS)

This ATS has been produced using the Tree and Tabular Combined Notation (TTCN) according to ISO/IEC 9646-3 [9].

The ATS was developed on a separate TTCN software tool and therefore the TTCN tables are not completely referenced in the table of contents. The ATS itself contains a test suite overview part which provides additional information and references.

C.1 The TTCN Graphical form (TTCN.GR)

The TTCN.GR representation of this ATS is contained in an Adobe Portable Document Format™ file (067_6_1.PDF contained in archive 9vpi0ie0.ZIP) which accompanies the present document.

C.1 The TTCN Machine Processable form (TTCN.MP)

The TTCN.MP representation corresponding to this ATS is contained in an ASCII file (067_6_1.MP contained in archive 9vpi0ie0.ZIP) which accompanies the present document.

Bibliography

The following material, though not specifically referenced in the body of the present document (or not publicly available), gives supporting information.

- ETS 300 406: "Methods for Testing and Specification (MTS); Protocol and profile conformance testing specifications; Standardization methodology".

History

Document history				
V1.1.1	April 1999	Public Enquiry	PE 9935:	1999-04-30 to 1999-08-27
V1.1.2	September 1999	Vote	V 9949:	1999-09-21 to 1999-11-19
V1.1.3	November 1999	Publication		