

Final draft **EN 301 039** V1.1.1 (1997-09)

European Standard (Telecommunications series)

**Private Integrated Services Network (PISN);
Mapping functions for the employment of 64 kbit/s
circuit mode connections with 16 kbit/s sub-multiplexing**



European Telecommunications Standards Institute

Reference

DEN/ECMA-00144 (9mc00ico.PDF)

Keywords

PISN

ETSI Secretariat

Postal address

F-06921 Sophia Antipolis Cedex - FRANCE

Office address

650 Route des Lucioles - Sophia Antipolis
Valbonne - FRANCE
Tel.: +33 4 92 94 42 00 Fax: +33 4 93 65 47 16
Siret N° 348 623 562 00017 - NAF 742 C
Association à but non lucratif enregistrée à la
Sous-Préfecture de Grasse (06) N° 7803/88

X.400

c= fr; a=atlas; p=etsi; s=secretariat

Internet

secretariat@etsi.fr
<http://www.etsi.fr>

Copyright Notification

No part may be reproduced except as authorized by written permission.
The copyright and the foregoing restriction extend to reproduction in all media.

Contents

Intellectual Property Rights.....	4
Foreword	4
1 Scope.....	5
2 Conformance.....	5
3 References.....	5
3.1 Normative references.....	5
3.2 Informative references.....	6
4 Definitions.....	6
4.1 External definitions.....	6
4.2 Special definitions.....	6
4.2.1 Channel.....	6
4.2.1.1 D _Q -Channel.....	6
4.2.1.2 U _Q -Channel.....	6
4.2.2 End PINX.....	6
4.2.3 Inter-PINX connection.....	7
4.2.4 Inter-PINX link.....	7
4.2.5 Transit PINX.....	7
5 Abbreviations.....	7
6 Introduction.....	7
7 Capabilities at the Q reference point.....	8
8 Mapping functions.....	8
8.1 Physical adaptation.....	8
8.1.1 64 kbit/s unrestricted digital leased line (D64U).....	8
8.2 Mapping matrix.....	9
8.2.1 Channel allocation.....	9
8.2.2 Bearer conditioning for the D _Q -Channel.....	9
8.2.3 Bearer conditioning for the U _Q -Channels.....	9
Annex A (normative): Implementation Conformance Statement (ICS) proforma.....	11
A.1 Introduction.....	11
A.2 Instructions for completing the ICS proforma.....	11
A.2.1 General structure of the ICS proforma.....	11
A.2.2 Additional information.....	12
A.2.3 Exception information.....	12
A.3 ICS proforma for PINX implementation.....	12
A.3.1 Implementation identification.....	12
A.3.2 Implementation summary.....	12
A.3.3 General.....	13
Annex B (normative): QSIG Protocol codepoints.....	14
Annex C (informative): Illustrative figure for bearer conditioning of U_Q-Channels.....	15
Annex D (informative): Bibliography.....	16
History.....	17

Intellectual Property Rights

IPRs essential or potentially essential to the present document may have been declared to ETSI. The information pertaining to these essential IPRs, if any, is publicly available for **ETSI members and non-members**, and can be found in ETR 314: "*Intellectual Property Rights (IPRs); Essential, or potentially Essential, IPRs notified to ETSI in respect of ETSI standards*", which is available **free of charge** from the ETSI Secretariat. Latest updates are available on the ETSI Web server (<http://www.etsi.fr/ipr>).

Pursuant to the ETSI Interim IPR Policy, no investigation, including IPR searches, has been carried out by ETSI. No guarantee can be given as to the existence of other IPRs not referenced in ETR 314 (or the updates on <http://www.etsi.fr/ipr>) which are, or may be, or may become, essential to the present document.

Foreword

This final draft European Standard (Telecommunications series) has been produced by the European Computer Manufacturers Association (ECMA) on behalf of its members and those of the European Telecommunications Standards Institute (ETSI), and is now submitted for the Voting phase of the ETSI standards Two-step Approval Procedure.

Proposed national transposition dates	
Date of latest announcement of this EN (doa):	3 months after ETSI publication
Date of latest publication of new National Standard or endorsement of this EN (dop/e):	6 months after doa
Date of withdrawal of any conflicting National Standard (dow):	6 months after doa

1 Scope

The present document defines the mapping functions in exchanges of Private Integrated Services Networks (PISNs) required for the utilization of scenarios in which 64 kbit/s circuit mode connections are sub-multiplexed into 4×16 kbit/s channels for carrying inter-Private Integrated services Network eXchange (PINX) signalling and user information.

NOTE: The present document has been prepared to meet the specific needs of an application for a particular user organization. However, it may also be applicable elsewhere. The requirements contained in the present document will be incorporated in any future standard specifying a more generic approach to bearer conditioning.

In order to connect a PINX to another PINX, mapping functions are required to adapt the specific interfaces at the C reference point to the application at the Q reference point. As such, mapping functions provide for physical adaptation to the interface at the C reference point. Mapping functions also provide for the mapping of user channels and signalling information at the Q reference point to the appropriate channels or timeslots at the C reference point.

The C and Q reference points are defined in ISO/IEC 11579-1 [1].

The type of interface at the C reference point covered by the present document is the 64 kbit/s digital unrestricted leased line (D64U) terminal equipment interface, in accordance with ETS 300 290 [2].

At the Q reference point the mapping provides a 16 kbit/s service for user channels to support the transfer of unrestricted digital information and to support the transfer of speech, and a packet mode service for the signalling channel. The applied mapping is a static mapping, i.e. there is a fixed relationship between user and signalling channels at the Q reference point and the interface at the C reference point.

Management functions relating to failure management are outside the scope of the present document.

The present document is applicable to PINXs that can be interconnected to form a PISN and that support signalling protocols at the Q reference point.

2 Conformance

In order to conform to the present document, a PINX shall satisfy the requirements identified in the Implementation Conformance Statement (ICS) proforma in annex A.

3 References

3.1 Normative references

References may be made to:

- a) specific versions of publications (identified by date of publication, edition number, version number, etc.), in which case, subsequent revisions to the referenced document do not apply; or
- b) all versions up to and including the identified version (identified by "up to and including" before the version identity); or
- c) all versions subsequent to and including the identified version (identified by "onwards" following the version identity); or
- d) publications without mention of a specific version, in which case the latest version applies.

A non-specific reference to an ETS shall also be taken to refer to later versions published as an EN with the same number.

- [1] ISO/IEC 11579-1 (1994): "Information technology - Telecommunications and information exchange between systems - Private Integrated Services Network - Part 1: Reference configuration for PISN Exchanges (PINX)".
- [2] ETS 300 290 (1994): "Business TeleCommunications (BTC); 64 kbit/s digital unrestricted leased line with octet integrity (D64U) Terminal equipment interface".
- [3] ETS 300 402-2 (1995): "Integrated Services Digital Network (ISDN); Digital Subscriber Signalling System No. one (DSS1) protocol; Data link layer; Part 2: General protocol specification".
- [4] CCITT Recommendation I.112 (1988): "Vocabulary of terms for ISDNs".
- [5] CCITT Recommendation I.460 (1988): "Multiplexing, rate adaption and support of existing interfaces".
- [6] ITU-T Recommendation G.728 (1992): "Coding of speech at 16 kbit/s using low-delay code excited linear prediction".

3.2 Informative references

The present document also contains informative references. Details of these publications are given in annex D.

4 Definitions

4.1 External definitions

For the purposes of the present document, the following external definitions apply:

Integrated Services Digital Network (ISDN) : See CCITT Recommendation I.112 [4].

Private Integrated Services Network (PISN): See ISO/IEC 11579-1 [1].

Private Integrated services Network eXchange (PINX): See ISO/IEC 11579-1 [1].

4.2 Special definitions

4.2.1 Channel

A means of bi-directional transmission of user or signalling information between two points.

4.2.1.1 D_Q-Channel

A channel used to convey call control information between the Q reference points of two peer PINXs.

4.2.1.2 U_Q-Channel

A channel used to convey user information between the Q reference points of two PINXs.

4.2.2 End PINX

In the context of a particular call, a PINX to which one of the users is attached (Originating PINX or Terminating PINX) or a PINX at which signalling interworking occurs (Gateway PINX).

4.2.3 Inter-PINX connection

A connection provided by an IVN between two C reference points used to transport inter-PINX information from the PISN control plane and/or the PISN user plane.

4.2.4 Inter-PINX link

A link between the Q reference points of two PINXs, comprising the totality of signalling transfer and user information transfer means.

4.2.5 Transit PINX

In the context of a particular call, any PINX, excluding the End PINXs, through which the call passes.

5 Abbreviations

BC	Bearer Conditioning
BTC	Business TeleCommunications
DSS1	Digital Subscriber Signalling System No. one
HDLC	High Level Data Link Control
ICS	Implementation Conformance Statement
IPC	Inter-PINX Connection
IPL	Inter-PINX Link
ISDN	Integrated Services Digital Network
IVN	InterVening Network
LD-CELP	Low-Delay Code Excited Linear Prediction
MP	MaPping functional grouping
PCM	Pulse Code Modulation
PINX	Private Integrated services Network eXchange
PISN	Private Integrated Services Network
PTNX	Private Telecommunications Network eXchange
QSIG	Q Interface Signalling protocol (ECMA standard)

6 Introduction

The present document specifies mapping functions for the following scenario.

Dedicated 64 kbit/s circuit mode connection with 16 kbit/s sub-multiplexing.

This scenario consists of a dedicated 64 kbit/s circuit mode connection in a point-to-point configuration, and offering at the C reference point an interface with a single 64 kbit/s channel. This 64 kbit/s channel is sub-multiplexed by the MaPping functional grouping (MP) into 4 x 16 kbit/s channels. Where such a channel is used for carrying speech, a speech compression function is also provided.

The applied mapping is a static mapping. There is a fixed relationship between user and signalling channels at the Q reference point and the interface at the C reference point.

Administrative actions to apply the mapping are necessary at both sides of an Inter-PINX Link (IPL).

At the C reference point more than one instance of the interface type may exist.

NOTE: For more information refer to ECMA TR/65 clause 7 (see annex D).

7 Capabilities at the Q reference point

For each instance of the Q reference point:

- 3 user channels (U_Q); and
- 1 signalling channel (D_Q) for carrying the inter-PINX layer 3 signalling protocol

are provided. The user channels are numbered 1...3.

For a U_Q -Channel the following bearer capabilities shall be provided:

- information transfer rate: 16 kbit/s;
- information transfer capability: speech; or
unrestricted digital information;
- user information layer 1 protocol: ITU-T Recommendation G.728[6], 16 kbit/s LD-CELP;
- other attributes shall be the same as at the C reference point.

NOTE 1: The user information layer 1 protocol is only specified as "LD-CELP" for the case where the information transfer capability is "speech". In the case where the information transfer capability is "unrestricted digital information", no user information layer 1 protocol is specified; it is an end-to-end matter between terminal equipments attached to a PISN.

NOTE 2: Annex B specifies the codepoints to be used by the QSIG protocol when implementing the mapping arrangements specified in the present document.

For a D_Q -Channel the following bearer capability shall be provided:

- transfer mode: packet mode;
- information transfer capability: unrestricted digital information;
- information transfer rate: 16 kbit/s;
- other attributes shall be the same as at the C reference point.

The functions to map D_Q -Channel and U_Q -Channel to an Inter-PINX Connection (IPC) at the C reference point are described in clause 8.

8 Mapping functions

The PINX mapping functions shall meet the following requirements.

8.1 Physical adaptation

A PINX shall support the following physical adaptation:

8.1.1 64 kbit/s unrestricted digital leased line (D64U)

Layer 1 termination shall be in accordance with ETS 300 290 [2].

At the C reference point, the interface described in this subclause provides for one IPC with the following bearer capabilities:

- information transfer mode: circuit mode;
- information transfer capability: unrestricted digital information;

- information transfer rate: 64 kbit/s.

The physical adaptation part of the mapping function shall maintain a fixed relationship between a 64 kbit/s IPC and the 16 kbit/s channels perceived at the Q reference point, according to the requirements for fixed format multiplexing specified in CCITT Recommendation I.460 [5] (paragraph 2.1.1).

NOTE: CCITT Recommendation I.460 [5] assumes bit positions in the 64 kbit/s octet are numbered from 1 to 8 with bit position 1 being the first transmitted. According to CCITT Recommendation G.711, bit position 1 corresponds to the most significant bit of the octet in an A-law PCM bitstream. By extrapolation, this convention is also true for an LD-CELP bitstream encoded according to ITU-T Recommendation G.728 [6]. For signalling information (e.g. HDLC at layer 2, QSIG at layer 3) bit 1 corresponds to the least significant bit in the octet. These conventions are maintained by the present document.

Each 64 kbit/s IPC shall be sub-multiplexed into four 16 kbit/s channels. Each 16 kbit/s channel shall be mapped to a pair of bit positions in the 64 kbit/s IPC as follows:

- the first 16 kbit/s channel shall be mapped to bit positions 1 and 2;
- the second 16 kbit/s channel shall be mapped to bit positions 3 and 4;
- the third 16 kbit/s channel shall be mapped to bit positions 5 and 6; and
- the fourth 16 kbit/s channel shall be mapped to bit positions 7 and 8.

8.2 Mapping matrix

The mapping matrix provides for the bearer conditioning and mapping of channels at the Q reference point to the channels provided by the physical adaptation function.

8.2.1 Channel allocation

A PINX shall support the mapping of a single instance of the Q reference point on to a single interface at the C reference point. Each channel at the Q reference point shall be mapped to a 16 kbit/s channel in the 64 kbit/s interface at the C reference point as follows:

- D_Q -Channel shall be mapped to the first 16 kbit/s channel;
- U_Q -Channel number 1 shall be mapped to the second 16 kbit/s channel;
- U_Q -Channel number 2 shall be mapped to the third 16 kbit/s channel; and
- U_Q -Channel number 3 shall be mapped to the fourth 16 kbit/s channel.

8.2.2 Bearer conditioning for the D_Q -Channel

The signalling carriage mechanism connection (layer 2) on a D_Q -Channel shall be according to the symmetrical application in annex ZA of ETS 300 402-2 [3].

At installation time one of the sides of the D_Q -Channel shall be designated as "master" and the other side of the D_Q -Channel as "slave".

8.2.3 Bearer conditioning for the U_Q -Channels

No bearer conditioning of the U_Q -Channels is necessary.

NOTE 1: Annex C illustrates the arrangement of functional groupings.

NOTE 2: A PINX may need to rate-adapt incoming user information to its internal channel rate to permit internal switching and processing.

For those calls in which it is acting as a Transit PINX, a PINX shall:

- map U_Q-Channels at the outgoing side into the outgoing 64 kbit/s IPC as specified in subclause 8.2.1;
- neither decompress received user information nor re-compress transmitted user information.

Annex A (normative): Implementation Conformance Statement (ICS) proforma

Notwithstanding the provisions of the copyright clause related to the text of the present document, ETSI grants that users of the present document may freely reproduce the ICS proforma in this annex so that it can be used for its intended purposes and may further publish the completed ICS.

A.1 Introduction

The supplier of a protocol implementation which is claimed to conform to the present document shall complete the Implementation Conformance Statement (ICS) proforma in clause A.3.

A completed ICS proforma is the ICS for the implementation in question. The ICS is a statement of which capabilities and options have been implemented. The ICS can have a number of uses, including use:

- by the equipment implementer, as a check list to reduce the risk of failure to conform to the relevant standard through oversight;
- by the supplier and acquirer, or potential acquirer, of the implementation, as a detailed indication of the capabilities of the implementation, stated relative to the common basis for understanding provided by the relevant standard's ICS proforma;
- by the user or potential user of an implementation, as a basis for initially checking the possibility of interworking with another implementation. While interworking can never be guaranteed, failure to interwork can often be predicted from incompatible ICSs.

A.2 Instructions for completing the ICS proforma

A.2.1 General structure of the ICS proforma

The ICS proforma is a fixed-format questionnaire divided into subclauses each containing a group of individual items. Each item is identified by an item number, the name of the item (question to be answered), and the reference(s) to the clause(s) that specifies (specify) the item in the main body of the present document.

The "Status" column indicates whether an item is applicable and if so whether support is mandatory or optional. The following terms are used:

m	mandatory (the capability is required for conformance);
o	optional (the capability is not required for conformance, but if the capability is implemented it is required to conform to the specifications);
o.<n>	optional, but support of at least one of the group of options labelled by the same numeral <n> is required;
x	prohibited;
c.<cond>	conditional requirement, depending on support for the item or items listed in condition <cond>;
<item>;m	simple conditional requirement, the capability being mandatory if item number <item> is supported, otherwise not applicable;
<item>;o	simple conditional requirement, the capability being optional if item number <item> is supported, otherwise not applicable.

Answers to the questionnaire items are to be provided either in the "Support" column, by simply marking an answer to indicate restricted choice (Yes) or (No), or in the "Not Applicable" column (N/A).

A.2.2 Additional information

Items of additional information allow a supplier to provide further information intended to assist the interpretation of the ICS. It is not intended that a large quantity will be supplied, and an ICS can be considered complete without such information. Examples might be an outline of the ways in which a (single) implementation can be set up to operate in a variety of environments and configurations.

References to items of additional information may be entered next to any answer in the questionnaire, and may be included in items of exception information.

A.2.3 Exception information

It may occasionally happen that a supplier will wish to answer an item with mandatory or prohibited status (after any conditions have been applied) in a way that conflicts with the indicated requirement. No pre-printed answer will be found in the support column for this. Instead, the supplier is required to write into the support column an x.<i> reference to an item of exception information, and to provide the appropriate rationale in the exception item itself.

An implementation for which an exception item is required in this way does not conform to the present document. A possible reason for the situation described above is that a defect in the standard has been reported, a correction for which is expected to change the requirement not met by the implementation.

A.3 ICS proforma for PINX implementation

A.3.1 Implementation identification

Supplier	
Contact point for queries about the ICS	
Implementation name(s) and version(s)	
Other information necessary for full identification, e.g. name(s) and version(s) for machines and/or operating systems; system name(s)	

Only the first three items are required for all implementations; other information may be completed as appropriate in meeting requirements for full identification.

The terms name and version should be interpreted appropriately to correspond with a supplier's terminology (e.g. type, series, model).

A.3.2 Implementation summary

Implementation version	1.0
Addenda implemented (if applicable)	
Amendments implemented	
Have any exception items been required (see subclause A.2.3)?	No [] Yes [] (The answer Yes means that the implementation does not conform to the present document)

Date of statement	
-------------------	--

A.3.3 General

Item	Name of Item	Reference	Status	N/A	Support
A1	Support of 64 kbit/s unrestricted digital leased line (D64U) interface with 16 kbit/s sub-multiplexing	8.1.1	m		Yes []
A2	Support of prescribed channel allocation	8.2.1	m		Yes []
A3	Support of bearer conditioning for the D _Q -Channel	8.2.2	m		Yes []
A4	Support of bearer conditioning for the U _Q -Channel	8.2.3	m		Yes []

Annex B (normative): QSIG Protocol codepoints

The present document defines the mapping functions for the following bearer capabilities at the Q reference point:

1) Speech:

- information transfer rate: 16 kbit/s;
- information transfer capability: speech;
- user information layer 1 protocol: ITU-T Recommendation G.728 [6]16 kbit/s LD-CELP.

2) Unrestricted digital:

- information transfer rate: 16 kbit/s;
- information transfer capability: unrestricted digital information.

Support of these bearer capabilities by a PINX requires the use of additional, application specific, codepoints in the Bearer capability information element of the QSIG protocol, as follows:

<u>Octet & field</u>	<u>Codepoint</u>	<u>Meaning</u>
Octet 3 - Coding standard:	1 0	National Standard
Octet 4 - Information transfer rate:	1 0 0 1 0	16 kbit/s
Octet 5 - User information layer 1 protocol:	0 1 0 1 0	G.728 LD-CELP

NOTE: Implementers and users should be aware that the codepoints defined in the table above are application specific and have not been internationally registered through either ITU-T or ISO/IEC. No provision has been made to cover the possibility of conflict with other applications using the same codepoints, but with different meanings. Similarly, no provisions have been made to deal with the case where a PINX cannot understand or process received messages containing the Bearer Capability (BC) information element encoded using these codepoints.

Annex C (informative): Illustrative figure for bearer conditioning of U_Q-Channels

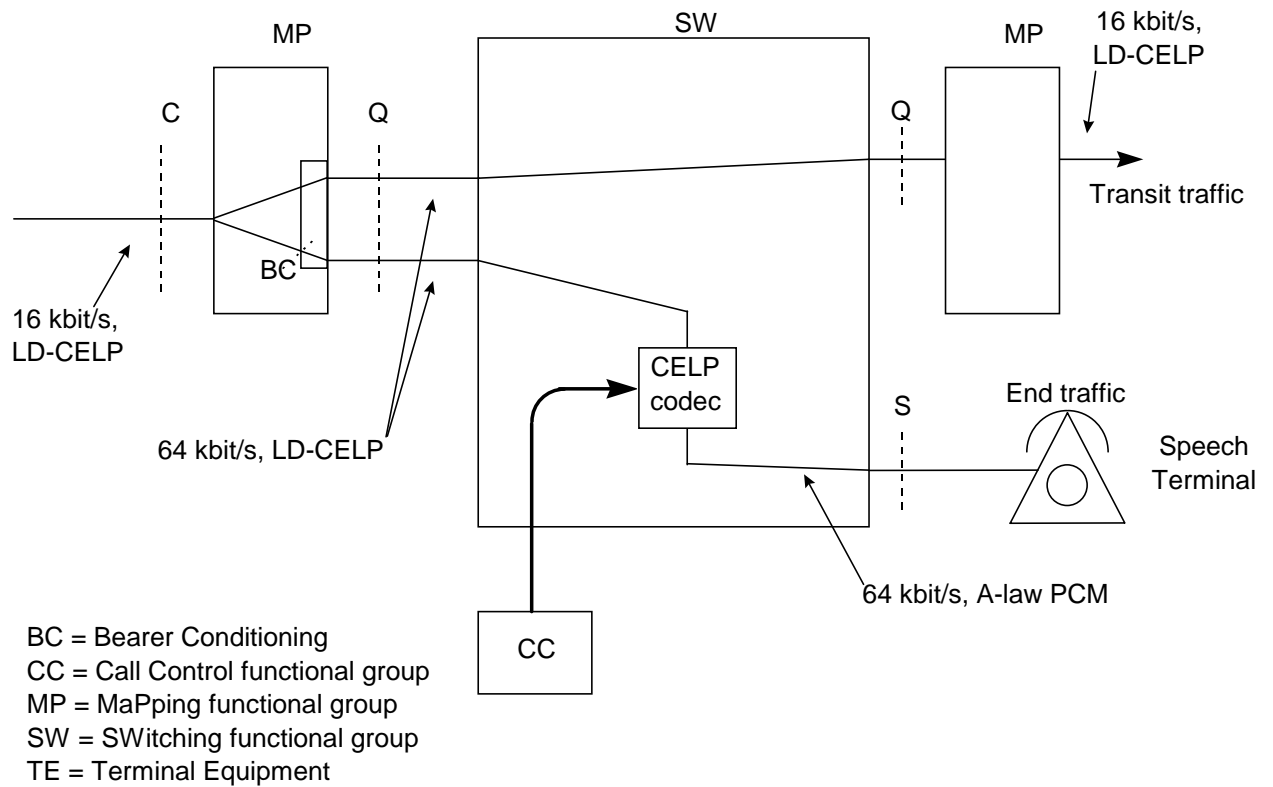

Figure C.1: Bearer conditioning and speech compression/decompression

Annex D (informative): Bibliography

The following material, though not specifically referenced in the body of the present document, gives supporting information:

- CCITT Recommendation G.711 (1984): "Pulse Code Modulation (PCM) of voice frequencies".
- ECMA TR/65 (1994): "PTNX Functions for the utilization of intervening networks in the provision of overlay scenarios (transparent approach) - General requirements (TR/Mapping)".

History

Document history				
V1.1.1	April 1997	Public Enquiry	PE 9733:	1997-04-18 to 1997-08-15
V1.1.1	September 1997	Vote	V 9748:	1997-09-30 to 1997-11-28