

Draft **EN 300 965** V6.0.0 (1999-01)

---

*European Standard (Telecommunications series)*

**Digital cellular telecommunications system (Phase 2+);  
Full rate speech;  
Voice Activity Detector (VAD)  
for full rate speech traffic channels  
(GSM 06.32 version 6.0.0 Release 1997)**

---



**GSM**®  
GLOBAL SYSTEM FOR  
MOBILE COMMUNICATIONS

**ETSI** 

---

**Reference**

---

DEN/SMG-110632Q6 (8xo03000.PDF)

---

**Keywords**

---

Digital cellular telecommunications system,  
Global System for Mobile communications (GSM)**ETSI**

---

**Postal address**

---

F-06921 Sophia Antipolis Cedex - FRANCE

---

**Office address**

---

650 Route des Lucioles - Sophia Antipolis  
Valbonne - FRANCE  
Tel.: +33 4 92 94 42 00 Fax: +33 4 93 65 47 16  
Siret N° 348 623 562 00017 - NAF 742 C  
Association à but non lucratif enregistrée à la  
Sous-Préfecture de Grasse (06) N° 7803/88

---

**Internet**

---

secretariat@etsi.fr  
Individual copies of this ETSI deliverable  
can be downloaded from  
<http://www.etsi.org>

---

**Copyright Notification**

---

No part may be reproduced except as authorized by written permission.  
The copyright and the foregoing restriction extend to reproduction in all media.

© European Telecommunications Standards Institute 1999.  
All rights reserved.

# Contents

Intellectual Property Rights.....	5
Foreword .....	5
0.1 Scope.....	6
0.2 References.....	6
0.3 Abbreviations.....	6
1 General.....	6
2 Functional description.....	7
2.1 Overview and principles of operation.....	7
2.2 Algorithm description.....	7
2.2.1 Adaptive filtering and energy computation.....	9
2.2.2 ACF averaging.....	9
2.2.3 Predictor values computation.....	9
2.2.4 Spectral comparison.....	10
2.2.5 Periodicity detection.....	10
2.2.6 Information tone detection.....	11
2.2.7 Threshold adaptation.....	12
2.2.8 VAD decision.....	14
2.2.9 VAD hangover addition.....	15
3 Computational details.....	15
3.1 Adaptive filtering and energy computation.....	17
3.2 ACF averaging.....	18
3.3 Predictor values computation.....	18
3.3.1 Schur recursion to compute reflection coefficients.....	18
3.3.2 Step-up procedure to obtain the aav1[0..8].....	19
3.3.3 Computation of the rav1[0..8].....	20
3.4 Spectral comparison.....	20
3.5 Periodicity detection.....	21
3.6 Threshold adaptation.....	21
3.7 VAD decision.....	23
3.8 VAD hangover addition.....	23
3.9 Periodicity updating.....	23
3.10 Tone detection.....	24
3.10.1 Windowing.....	24
3.10.2 Auto-correlation.....	24
3.10.3 Computation of the reflection coefficients.....	25
3.10.4 Filter coefficient calculation.....	25
3.10.5 Pole Frequency Test.....	26
3.10.6 Prediction gain test.....	26
4 Digital test sequences.....	27
4.1 Test configuration.....	27
4.2 Test sequences.....	28
<b>Annex A (informative):.....</b>	<b>29</b>
A.1 Simplified block filtering operation.....	29
A.2 Description of digital test sequences.....	29
A.2.1 Test sequences.....	29
A.2.2 File format description.....	31

A.3 VAD performance .....33

A.4 Pole frequency calculation .....34

**Annex B (normative): Test sequences .....35**

**Annex C (informative): Change Request History .....36**

History .....37

---

## Intellectual Property Rights

IPRs essential or potentially essential to the present document may have been declared to ETSI. The information pertaining to these essential IPRs, if any, is publicly available for **ETSI members and non-members**, and can be found in SR 000 314: "*Intellectual Property Rights (IPRs); Essential, or potentially Essential, IPRs notified to ETSI in respect of ETSI standards*", which is available **free of charge** from the ETSI Secretariat. Latest updates are available on the ETSI Web server (<http://www.etsi.org/ipr>).

Pursuant to the ETSI IPR Policy, no investigation, including IPR searches, has been carried out by ETSI. No guarantee can be given as to the existence of other IPRs not referenced in SR 000 314 (or the updates on the ETSI Web server) which are, or may be, or may become, essential to the present document.

---

## Foreword

This European Standard (Telecommunications series) has been produced by ETSI Technical Committee Special Mobile Group (SMG), and is now submitted to the ETSI standards One-step Approval Procedure.

The present document specifies the Voice Activity Detector (VAD) to be used in the Discontinuous Transmission (DTX) for the digital cellular telecommunications system.

Archive 8xo03000.ZIP which accompanies the present document, contains test sequences, as described in clause A.2.

8xo03000.ZIP     Annex B: Test sequences for the GSM Full Rate speech codec; Test sequences files \*.inp, \*.cod, \*.vad.

The specification from which the present document has been derived was originally based on CEPT documentation, hence the presentation of the present document may not be entirely in accordance with the ETSI/PNE Rules.

The contents of the present document is subject to continuing work within SMG and may change following formal SMG approval. Should SMG modify the contents of the present document it will be re-released with an identifying change of release date and an increase in version number as follows:

Version 6.x.y

where:

- 6 indicates Release 1997 of GSM Phase 2+
- x the second digit is incremented for all changes of substance, i.e. technical enhancements, corrections, updates, etc.
- y the third digit is incremented when editorial only changes have been incorporated in the specification.

<b>Proposed national transposition dates</b>	
Date of latest announcement of this EN (doa):	3 months after ETSI publication
Date of latest publication of new National Standard or endorsement of this EN (dop/e):	6 months after doa
Date of withdrawal of any conflicting National Standard (dow):	6 months after doa

---

## 0.1 Scope

This European Standard (EN) specifies the Voice Activity Detector (VAD) to be used in the Discontinuous Transmission (DTX) as described in GSM 06.31. It also specifies the test methods to be used to verify that a VAD complies with the technical specification.

The requirements are mandatory on any VAD to be used either in the GSM Mobile Stations (MS)s or Base Station Systems (BSS)s.

---

## 0.2 References

The following documents contain provisions which, through reference in this text, constitute provisions of the present document.

- References are either specific (identified by date of publication, edition number, version number, etc.) or non-specific.
- For a specific reference, subsequent revisions do not apply.
- For a non-specific reference, the latest version applies.
- A non-specific reference to an ETS shall also be taken to refer to later versions published as an EN with the same number.

- [1] GSM 01.04: "Digital cellular telecommunications system (Phase 2+); Abbreviations and acronyms".
- [2] GSM 06.10: "Digital cellular telecommunications system(Phase 2+); Full rate speech; Transcoding".
- [3] GSM 06.12: "Digital cellular telecommunications system(Phase 2+); Full rate speech; Comfort noise aspect for full rate speech traffic channels".
- [4] GSM 06.31: "Digital cellular telecommunications system(Phase 2+); Full rate speech; Discontinuous Transmission (DTX) for full rate speech traffic channels".

---

## 0.3 Abbreviations

Abbreviations used in the present document are listed in GSM 01.04 [1].

---

## 1 General

The function of the VAD is to indicate whether each 20 ms frame produced by the speech encoder contains speech or not. The output is a binary flag which is used by the TX DTX handler defined in GSM 06.31 [4].

The ETS is organized as follows:

Clause 2 describes the principles of operation of the VAD.

In clause 3, the computational details necessary for the fixed point implementation of the VAD algorithm are given. This clause uses the same notation as used for computational details in GSM 06.10.

The verification of the VAD is based on the use of digital test sequences. Clause 4 defines the input and output signals and the test configuration, whereas the detailed description of the test sequences is contained in clause A.2.

The performance of the VAD algorithm is characterized by the amount of audible speech clipping it introduces and the percentage activity it indicates. These characteristics for the VAD defined in the present document have been established by extensive testing under a wide range of operating conditions. The results are summarized in clause A.3.

---

## 2 Functional description

The purpose of this clause is to give the reader an understanding of the principles of operation of the VAD, whereas the detailed description is given in clause 3. In case of discrepancy between the two descriptions, the detailed description of clause 3 shall prevail.

In the following subclauses of clause 2, a Pascal programming type of notation has been used to describe the algorithm.

### 2.1 Overview and principles of operation

The function of the VAD is to distinguish between noise with speech present and noise without speech present. The biggest difficulty for detecting speech in a mobile environment is the very low speech/noise ratios which are often encountered. The accuracy of the VAD is improved by using filtering to increase the speech/noise ratio before the decision is made.

For a mobile environment, the worst speech/noise ratios are encountered in moving vehicles. It has been found that the noise is relatively stationary for quite long periods in a mobile environment. It is therefore possible to use an adaptive filter with coefficients obtained during noise, to remove much of the vehicle noise.

The VAD is basically an energy detector. The energy of the filtered signal is compared with a threshold; speech is indicated whenever the threshold is exceeded.

The noise encountered in mobile environments may be constantly changing in level. The spectrum of the noise can also change, and varies greatly over different vehicles. Because of these changes the VAD threshold and adaptive filter coefficients must be constantly adapted. To give reliable detection the threshold must be sufficiently above the noise level to avoid noise being identified as speech but not so far above it that low level parts of speech are identified as noise. The threshold and the adaptive filter coefficients are only updated when speech is not present. It is, of course, potentially dangerous for a VAD to update these values on the basis of its own decision. This adaptation therefore only occurs when the signal seems stationary in the frequency domain but does not have the pitch component inherent in voiced speech. A tone detector is also used to prevent adaptation during information tones.

A further mechanism is used to ensure that low level noise (which is often not stationary over long periods) is not detected as speech. Here, an additional fixed threshold is used.

A VAD hangover period is used to eliminate mid-burst clipping of low level speech. Hangover is only added to speech-bursts which exceed a certain duration to avoid extending noise spikes.

### 2.2 Algorithm description

The block diagram of the VAD algorithm is shown in figure 2.1. The individual blocks are described in the following subclauses. ACF, N and sof are calculated in the speech encoder.

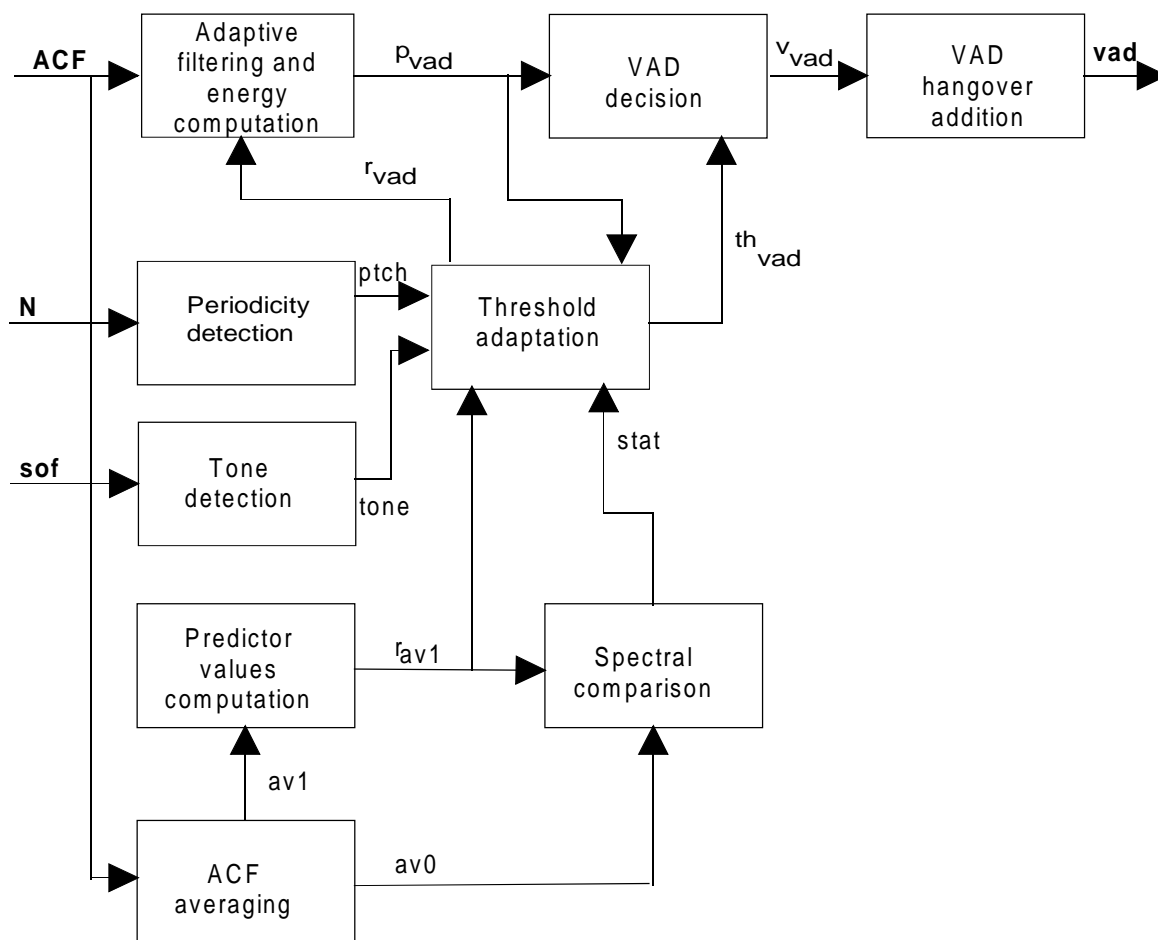

**Figure 2.1: Functional block diagram of the VAD**

The global variables shown in the block diagram are described as follows:

- ACF are auto-correlation coefficients which are calculated in the speech encoder defined in GSM 06.10 (subclause 3.1.4, see also clause A.1). The inputs to the speech encoder are 16 bit 2's complement numbers, as described in GSM 06.10, subclause 4.2.0.
- av0 and av1 are averaged ACF vectors.
- rav1 are autocorrelated predictor values obtained from av1.
- rvad are the autocorrelated predictor values of the adaptive filter.
- N is the long term predictor lag value which is obtained every sub-segment in the speech coder defined in GSM 06.10.
- ptch indicates whether the signal has a steady periodic component.
- sof is the offset compensated signal frame obtained in the speech coder defined in GSM 06.10.
- p<sub>vad</sub> is the energy in the current frame of the input signal after filtering.
- th<sub>vad</sub> is an adaptive threshold.
- stat indicates spectral stationarity.
- v<sub>vad</sub> indicates the VAD decision before hangover is added.
- vad is the final VAD decision with hangover included.



### 2.2.1 Adaptive filtering and energy computation

Pvad is computed as follows:

$$Pvad = rvad_0 acf_0 + 2 \sum_{i=1}^8 rvad_i acf_i$$

This corresponds to performing an 8th order block filtering on the input samples to the speech encoder, after zero offset compensation and pre-emphasis. This is explained in clause A.1.

### 2.2.2 ACF averaging

Spectral characteristics of the input signal have to be obtained using blocks that are larger than one 20 ms frame. This is done by averaging the auto-correlation values for several consecutive frames. This averaging is given by the following equations:

$$av0\{n\}_i = \sum_{j=0}^{frames-1} acf\{n-j\}_i \quad ; i = 0..8$$

$$av1\{n\}_i = av0\{n-frames\}_i \quad ; i = 0..8$$

Where n represents the current frame, n-1 represents the previous frame etc. The values of constants are given in table 2.1.

**Table 2.1: Constants and variables for ACF averaging**

Constant	Value	Variable	Initial value
frames	4	previous ACF's av0 & av1	All set to 0

### 2.2.3 Predictor values computation

The filter predictor values aav1 are obtained from the auto-correlation values av1 according to the equation:

$$\underline{a} = \underline{R}^{-1} \underline{p}$$

where:

$$\underline{R} = \begin{bmatrix} av1[0] & av1[1] & av1[2] & av1[3] & av1[4] & av1[5] & av1[6] & av1[7] \\ av1[1] & av1[0] & av1[1] & av1[2] & av1[3] & av1[4] & av1[5] & av1[6] \\ av1[2] & av1[1] & av1[0] & av1[1] & av1[2] & av1[3] & av1[4] & av1[5] \\ av1[3] & av1[2] & av1[1] & av1[0] & av1[1] & av1[2] & av1[3] & av1[4] \\ av1[4] & av1[3] & av1[2] & av1[1] & av1[0] & av1[1] & av1[2] & av1[3] \\ av1[5] & av1[4] & av1[3] & av1[2] & av1[1] & av1[0] & av1[1] & av1[2] \\ av1[6] & av1[5] & av1[4] & av1[3] & av1[2] & av1[1] & av1[0] & av1[1] \\ av1[7] & av1[6] & av1[5] & av1[4] & av1[3] & av1[2] & av1[1] & av1[0] \end{bmatrix}$$

and:

$$\begin{array}{l}
 \mathbf{p} = \begin{array}{|c} \hline |av1[1]| \\ |av1[2]| \\ |av1[3]| \\ |av1[4]| \\ |av1[5]| \\ |av1[6]| \\ |av1[7]| \\ |av1[8]| \\ \hline \end{array}
 \end{array}
 \qquad
 \begin{array}{l}
 \mathbf{a} = \begin{array}{|c} \hline |aav1[1]| \\ |aav1[2]| \\ |aav1[3]| \\ |aav1[4]| \\ |aav1[5]| \\ |aav1[6]| \\ |aav1[7]| \\ |aav1[8]| \\ \hline \end{array}
 \end{array}$$

aav1[0] = -1

av1 is used in preference to av0 as av0 may contain speech.

The autocorrelated predictor values rav1 are then obtained:

$$rav1_i = \sum_{k=0}^{8-i} aav1_k aav1_{k+i} \qquad ; i = 0..8$$

### 2.2.4 Spectral comparison

The spectra represented by the autocorrelated predictor values rav1 and the averaged auto-correlation values av0 are compared using the distortion measure dm defined below. This measure is used to produce a Boolean value stat every 20 ms, as given by these equations:

$$dm = \frac{\left( rav1_0 av0_0 + 2 \sum_{i=1}^8 rav1_i av0_i \right)}{av0_0}$$

difference = |dm - lastdm|

lastdm = dm

stat = difference < thresh

The values of constants and initial values are given in table 2.2.

**Table 2.2: Constants and variables for spectral comparison**

Constant	Value	Variable	Initial value
thresh	0.05	lastdm	0

### 2.2.5 Periodicity detection

The frequency spectrum of mobile noise is relatively stationary over quite long periods. The Inverse Filter Autocorrelated Predictor coefficients of the adaptive filter rvad are only updated when this stationarity is detected. Vowel sounds however, also have this stationarity, but can be excluded by detecting the periodicity of these sounds using the long term predictor lag values (Nj) which are obtained every sub-segment from the speech codec defined in GSM 06.10. Consecutive lag values are compared. Cases in which one lag value is a factor of the other are catered for, however cases in which both lag values have a common factor, are not. This case is not important for speech input but this method of periodicity detection may fail for some sine waves. The Boolean variable ptch is updated every 20 ms and is true when periodicity is detected. It is calculated according to the following equation:

ptch = oldlagcount + veryoldlagcount >= nthresh

The following operations are done after the VAD decision and when the current LTP lag values (N0 .. N3) are available, this reduces the delay of the VAD decision. (N{-1} = N3 of previous segment.)

lagcount = 0

```

for j = 0 to 3 do
begin
  smallag = maximum(Nj,N{j-1}) mod minimum(Nj,N{j-1})
  if minimum(smallag,minimum(Nj,N{j-1}))-smallag < lthresh
  then increment(lagcount)
end

veryoldlagcount = oldlagcount

oldlagcount = lagcount

```

The values of constants and initial values are given in table 2..

**Table 2.3: Constants and variables for periodicity detection**

Constant	Value	Variable	Initial value
lthresh	2	oldlagcount	0
nthresh	4	veryoldlagcount	0
		N3	40

## 2.2.6 Information tone detection

The tone flag is only evaluated in the downlink VAD. In the uplink VAD, tone detection is not performed and tone = false.

Computation of the tone flag is complex. It is therefore evaluated after the processing of the current speech encoder frame. In this way transmission of the speech or SID frame is not delayed.

Information tones and environmental noise can be classified by inspecting the short term prediction gain, information tones resulting in higher prediction gains than environmental noise. Tones can therefore be detected by comparing the prediction gain to a fixed threshold. By limiting the prediction gain calculation to a fourth order analysis, information signals consisting of one or two tones can be detected whilst minimizing the prediction gain for environmental noise.

The prediction gain decision is implemented by comparing the normalized prediction error with a threshold. This measure is used to evaluate the Boolean variable tone every 20 ms. The signal is classified as a tone if the prediction error is smaller than the threshold predth. This is equivalent to a prediction gain threshold of 13,5 dB.

Mobile noise can contain very strong resonances at low frequencies, resulting in a high prediction gain. A further test is therefore made to determine the pole frequency of a second order analysis of the signal frame. The signal is classified as noise if the frequency of the pole is less than 385 Hz. The pole frequency calculation is described in clause A.4.

The algorithm for detecting information tones is as follows:

```

tone = false

den = a[1]*a[1]
num = 4*a[2] - a[1]*a[1]

if ( num <= 0 )
  return

if (( a[1] < 0 ) AND ( num / den < freqth ))
  return

prederr = MULT 4 (1 - RC[i]*RC[i])
           i=1

if (prederr < predth)
  tone = true

return

```

The values of the constants are given in table 2.4. The coefficients a[1..2] are transversal filter coefficients calculated from rc[1..2]. The calculation of the reflection coefficients rc[1..4] is described below.

The offset compensated signal frame sof[0..159] is multiplied by the Hanning window to give the windowed frame sof<sub>h</sub>[0..159]:

$$sof_{hi} = sof_i \text{hann}_i \quad i = 0..159$$

where

$$hann_i = 0.5 \left( 1 - \cos \left( 2\pi \left( \frac{i}{159} \right) \right) \right) \quad i = 0..159$$

The auto-correlation  $acfh[0..4]$  of the windowed signal frame is then calculated:

$$acfh_k = \sum_{i=k}^{159} sofh_i sofh_{i-k} \quad ; k = 0..4$$

$rc[1..4]$  are then calculated from  $acfh[0..4]$  using the Schur recursion described in the RPE-LTP codec.

**Table 2.4: Constants for information tone detection.**

Constant	Value
freqth	0,0973
predth	0,0158

NOTE: Reflection coefficients are available in the RPE-LTP codec. However, they are calculated after pre-emphasis using a rectangular window and do not give good tone detection results.

## 2.2.7 Threshold adaptation

A check is made every 20 ms to determine whether the VAD decision threshold (thvad) should be changed. This adaptation is carried out according to the flowchart shown in figure 2.2. The constants used are given in table 2.5.

Adaptation takes place in two different situations: firstly whenever  $ACF[0]$  is very low and secondly whenever there is a very high probability that speech and information tones are not present.

In the first case, the threshold is adapted if the energy of the input signal is less than pth. The threshold is set to plev without carrying out any further tests because at these very low levels the effect of the signal quantization makes it impossible to obtain reliable results from these tests.

In the second case, the decision threshold (thvad) and the adaptive filter coefficients (rvad) are only updated with the  $rav1$  values when there is a very high probability that speech and information tones are not present. Adaptation occurs if the following conditions are met over a number (adp) of signal frames:

- Stationarity is detected in the frequency domain.
- The signal does not contain a periodic component.
- Information tones are not present.

The step-size by which the threshold is adapted is not constant but a proportion of the current value (determined by constants dec and inc). The adaptation begins by experimentally multiplying the threshold by a factor of  $(1-1/dec)$ . If the new threshold is now higher than or equal to  $Pvad$  times fac then the threshold needed to be decreased and it is left at this new lower level. If, on the other hand, the new threshold level is less than  $Pvad$  times fac then the threshold either needed to be increased or kept constant. In this case it is set to  $Pvad$  times fac unless this would mean multiplying it by more than a factor of  $(1+1/inc)$  (in which case it is multiplied by a factor of  $(1+1/inc)$ ). The threshold is never allowed to be greater than  $Pvad+margin$ .

**Table 2.5: Constants and variables for threshold adaptation**

Constant	Value	Variable	Initial value
pth	300 000	adaptcount	0
plev	800 000	thvad	1 000 000
fac	3.0	rvad[0]	6
adp	8	rvad[1]	-4
inc	16	rvad[2]	1
dec	32	rvad[3] to	
margin	80 000 000	rvad[8]	All 0

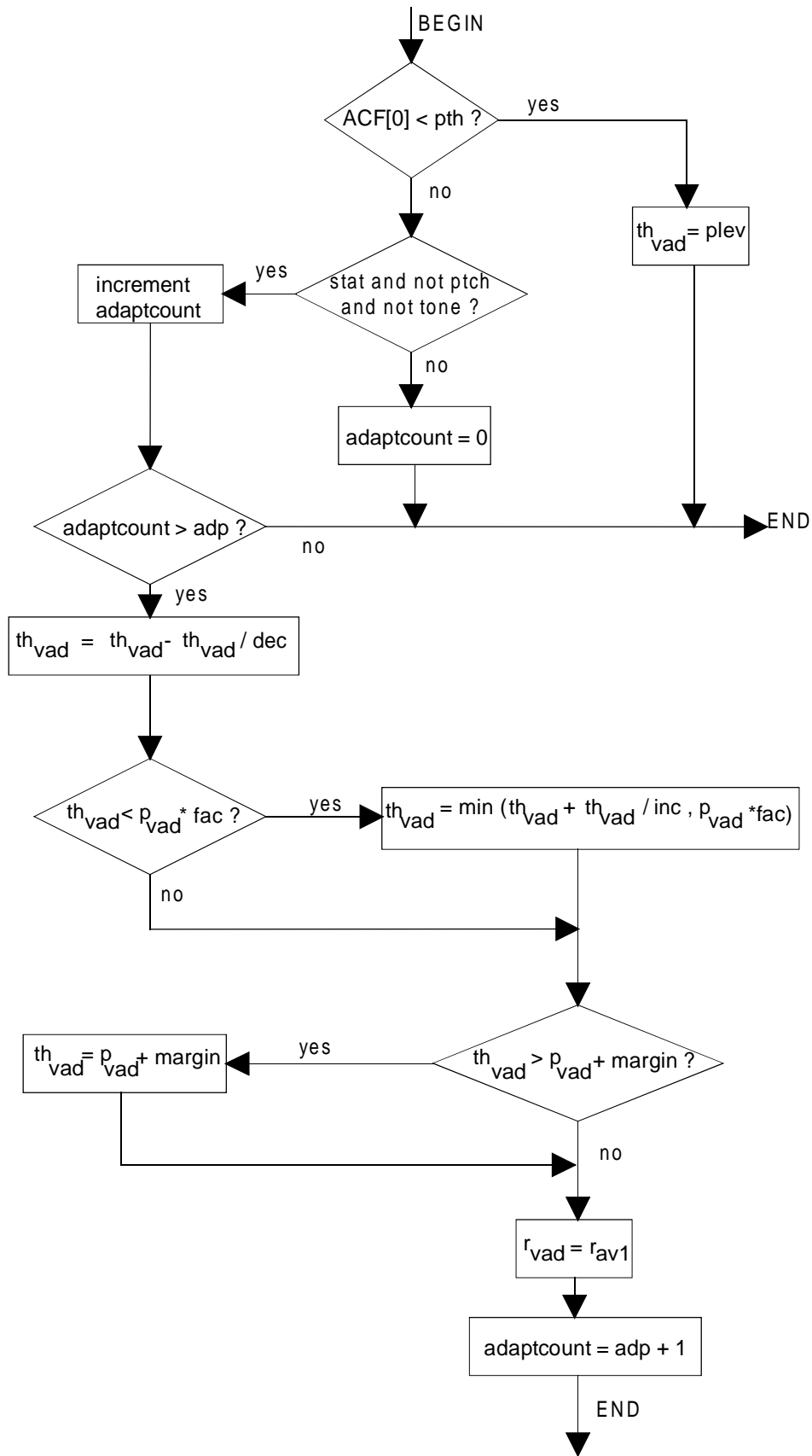

Figure 2.2: Flow diagram for threshold adaptation

## 2.2.8 VAD decision

Prior to hangover the VAD decision condition is:

```
vvad = pvad > thvad
```

## 2.2.9 VAD hangover addition

VAD hangover is only added to bursts of speech greater than or equal to burstconst blocks. The Boolean variable vad indicates the decision of the VAD with hangover included. The values of the constants are given in table 2.6. The hangover algorithm is as follows:

```
if vvad then increment(burstcount) else burstcount = 0

if burstcount >= burstconst then
begin
  hangcount = hangconst;
  burstcount = burstconst
end

vad = vvad or (hangcount >= 0)

if hangcount >= 0 then decrement(hangcount)
```

**Table 2.6: Constants and variables for VAD hangover addition**

Constant	Value	Variable	Initial value
burstconst	3	burstcount	0
hangconst	5	hangcount	-1

## 3 Computational details

In the next paragraphs, the detailed description of the VAD algorithm follows the preceding high level description. This detailed description is divided in ten clauses related to the blocks of figure 2.1 (except periodicity updating) in the high level description of the VAD algorithm.

Those clauses are:

- 1) Adaptive filtering and energy computation;
- 2) ACF averaging;
- 3) Predictor values computation;
- 4) Spectral comparison;
- 5) Periodicity detection;
- 6) Threshold adaptation;
- 7) VAD decision;
- 8) VAD hangover addition;
- 9) Periodicity updating;
- 10) Information tone detection.

The VAD algorithm takes as input the following variables of the RPE-LTP encoder (see the detailed description of the RPE-LTP encoder GSM 06.10):

- L\_ACF[0..8], auto-correlation function (GSM 06.10/4.2.4);
- scalauto, scaling factor to compute the L\_ACF[0..8] (GSM 06.10/4.2.4);
- Nc, LTP lag (one for each sub-segment, GSM 06.10/4.2.11).
- sof, offset compensated signal frame (GSM 06.10/4.2.2).

So four Nc values are needed for the VAD algorithm.

The VAD computation can start as soon as the  $L\_ACF[0..8]$  and  $scalauto$  variables are known. This means that the VAD computation can take place after part 4.2.4 of GSM 06.10 (Auto-correlation) of the LPC analysis clause of the RPE-LTP encoder. This scheme will reduce the delay to yield the VAD information. The periodicity updating (included in subclause 2.2.5) and information tone detection, are done after the processing of the current speech encoder frame.

All the arithmetic operations and names of the variables follow the RPE-LTP detailed description. To increase the precision within the fixed point implementation, a pseudo-floating point representation of some variables is used. This stands for the following variables (and related constants) of the VAD algorithm:

- pvad: Energy of filtered signal;
- thvad: Threshold of the VAD decision;
- acf0: Energy of input signal.

For the representation of these variables, two integers (16 bits) are needed:

- one for the exponent ( $e\_pvad$ ,  $e\_thvad$ ,  $e\_acf0$ );
- one for the mantissa ( $m\_pvad$ ,  $m\_thvad$ ,  $m\_acf0$ ).

The value  $e\_pvad$  represents the lowest power of 2 just greater or equal to the actual value of  $pvad$  and the  $m\_pvad$  value represents a integer which is always greater or equal to 16384 (normalized mantissa). It means that the  $pvad$  value is equal to:

$$pvad = 2^{e\_pvad} * (m\_pvad / 32768)$$

This scheme guarantees a large dynamic range for the  $pvad$  value and always keeps a precision of 16 bits. All the comparisons are easy to make by comparing the exponents of two variables and the VAD algorithm needs only one pseudo-floating point addition. All the computations related to the pseudo-floating point variables require very simple 16 or 32 bits arithmetic operations defined in the detailed description of the RPE-LTP encoder. This pseudo-floating point arithmetic is only used in subclauses 3.1 and 3.6.

Table 3.1 gives a list of all the variables of the VAD algorithm that must be initialized in the reset procedure and kept in memory for processing the subsequent frame of the RPE- LTP encoder. The types (16 or 32 bits) and initial values of all these variables are clearly indicated and their related subclause is also mentioned. The bit exact implementation uses other temporary variables that are introduced in the detailed description whenever it is needed.



Table 3.1: Initial values for variables to be stored in memory

Names of variables:	type (# of bits):	Initialization:	Subclause:
Adaptive filter coefficients:			
rvad[0]	16	24 576	3.1, 3.6
rvad[1]	16	-16 384	3.1, 3.6
rvad[2]	16	4 096	3.1, 3.6
rvad[3..8]	16	0	3.1, 3.6
Scaling factor of ravad[0..8]:			
normrvad	16	7	3.1, 3.6
Delay line of the auto-correlation coefficients:			
L_sacf[0..26]	32	0	3.2
L_sav0[0..35]	32	0	3.2
Pointers on the delay lines:			
pt_sacf	16	0	3.2
pt_sav0	16	0	3.2
Distance measure:			
L_lastdm	32	0	3.4
Periodicity counters:			
oldlagcount	16	0	3.5, 3.9
veryoldlagcount	16	0	3.5, 3.9
Adaptive threshold:			
e_thvad (exponent)	16	20	3.6
m_thvad (mantissa)	16	31 250	3.6
Counter for adaptation:			
adaptcount	16	0	3.6
Hangover flags:			
burstcount	16	0	3.8
hangcount	16	-1	3.8
LTP lag memory:			
oldlag	16	40	3.9
Tone Detection			
tone	16	0	3.10

### 3.1 Adaptive filtering and energy computation

This subclause computes the `e_pvad` and `m_pvad` variables which represent the `pvad` value. It needs the `L_ACF[0..8]` and `scalauto` variables of the RPE-LTP algorithm and the `rvad[0..8]` and `normrvad` variables produced by subclause 3.6 of the VAD algorithm. It also computes a floating point representation of `L_ACF[0]` (`e_acf0` and `m_acf0`) used in subclause 3.6.

#### Test if `L_ACF[0]` is equal to 0:

```

IF ( scalauto < 0 ) THEN scalvad = 0;
ELSE scalvad = scalauto; / keep scalvad for use in subclause 3.2 /

IF ( L_ACF[0] == 0 ) THEN
    e_pvad = -32768;
    m_pvad = 0;
    e_acf0 = -32768;
    m_acf0 = 0;
    EXIT /continue with subclause 3.2/

```

#### Re-normalization of the `L_ACF[0..8]`:

```

normacf = norm( L_ACF[0] );

FOR i = 0 to 8:
    sacf[i] = ( L_ACF[i] << normacf ) >> 19;
NEXT i:

```

#### Computation of `e_acf0` and `m_acf0`:

```
e_acf0 = add( 32, (scalvad << 1) );
e_acf0 = sub( e_acf0, normacf );
m_acf0 = sacf[0] << 3;
```

#### Computation of e\_pvad and m\_pvad:

```
e_pvad = add( e_acf0, 14 );
e_pvad = sub( e_pvad, normrvad );

L_temp = 0;

| FOR i = 1 to 8:
|   L_temp = L_add( L_temp, L_mult( sacf[i], rvad[i] ) );
| NEXT i:

L_temp = L_add( L_temp, L_mult( sacf[0], rvad[0] ) >> 1 );

IF ( L_temp <= 0 ) THEN L_temp = 1;

normprod = norm( L_temp );
e_pvad = sub( e_pvad, normprod );
m_pvad = ( L_temp << normprod ) >> 16;
```

## 3.2 ACF averaging

This subclause uses the L\_ACF[0..8] and the scalvad variables to compute the array L\_av0[0..8] and L\_av1[0..8] used in subclause 3.3 and 3.4.

#### Computation of the scaling factor:

```
scal = sub( 10, (scalvad << 1) );
```

#### Computation of the arrays L\_av0[0..8] and L\_av1[0..8]:

```
| FOR i = 0 to 8:
|   L_temp = L_ACF[i] >> scal;
|   L_av0[i] = L_add( L_sacf[i], L_temp );
|   L_av0[i] = L_add( L_sacf[i+9], L_av0[i] );
|   L_av0[i] = L_add( L_sacf[i+18], L_av0[i] );
|   L_sacf[ pt_sacf + i ] = L_temp;
|   L_av1[i] = L_sav0[ pt_sav0 + i ];
|   L_sav0[ pt_sav0 + i ] = L_av0[i];
| NEXT i:
```

#### Update of the array pointers:

```
IF ( pt_sacf == 18 ) THEN pt_sacf = 0;
ELSE pt_sacf = add( pt_sacf, 9 );

IF ( pt_sav0 == 27 ) THEN pt_sav0 = 0;
ELSE pt_sav0 = add( pt_sav0, 9 );
```

## 3.3 Predictor values computation

This subclause computes the array rav1[0..8] needed for the spectral comparison and the threshold adaptation. It uses the L\_av1[0..8] computed in subclause 3.2, and is divided in the three following subclauses:

- Schur recursion to compute reflection coefficients.
- Step up procedure to obtain the aav1[0..8].
- Computation of the rav1[0..8].

### 3.3.1 Schur recursion to compute reflection coefficients

This subclause is identical to the one used in the RPE-LTP algorithm. The array vpar[1..8] is computed with the array L\_av1[0..8] as an input.

**Schur recursion with 16 bits arithmetic:**

```

IF( L_av1[0] == 0 ) THEN
    == FOR i = 1 to 8:
        vpar[i] = 0;
    == NEXT i:
        EXIT; /continue with subclause 3.3.2/
temp = norm( L_av1[0] );
== FOR k=0 to 8:
    sacf[k] = ( L_av1[k] << temp ) >> 16;
== NEXT k:

```

**Initialize array P[..] and K[..] for the recursion:**

```

== FOR i=1 to 7:
    K[9-i] = sacf[i];
== NEXT i:

== FOR i=0 to 8:
    P[i] = sacf[i];
== NEXT i:

```

**Compute reflection coefficients:**

```

== FOR n=1 to 8:
    IF( P[0] < abs( P[1] ) ) THEN
        == FOR i = n to 8:
            vpar[i] = 0;
        == NEXT i:
            EXIT; /continue with
                subclause 3.3.2/
        vpar[n] = div( abs( P[1] ), P[0] );
        IF ( P[1] > 0 ) THEN vpar[n] = sub( 0, vpar[n] );
        IF ( n == 8 ) THEN EXIT; /continue with subclause 3.3.2/

    Schur recursion:

        P[0] = add( P[0], mult_r( P[1], vpar[n] ) );
    ==== FOR m=1 to 8-n:
        P[m] = add( P[m+1], mult_r( K[9-m], vpar[n] ) );
        K[9-m] = add( K[9-m], mult_r( P[m+1], vpar[n] ) );
    ==== NEXT m:

== NEXT n:

```

**3.3.2 Step-up procedure to obtain the aav1[0..8]****Initialization of the step-up recursion:**

```

L_coef[0] = 16384 << 15;
L_coef[1] = vpar[1] << 14;

```

**Loop on the LPC analysis order:**

```

= FOR m = 2 to 8:
== FOR i = 1 to m-1:
== temp = L_coef[m-i] >> 16; / takes the msb /
== L_work[i] = L_add( L_coef[i], L_mult( vpar[m], temp ) );
== NEXT i
=
== FOR i = 1 to m-1:
== L_coef[i] = L_work[i];
== NEXT i
=
= L_coef[m] = vpar[m] << 14;
= NEXT m:

```

**Keep the aav1[0..8] on 13 bits for next clause:**

```

FOR i = 0 to 8:
    aav1[i] = L_coef[i] >> 19;
NEXT i:

```

### 3.3.3 Computation of the rav1[0..8]

```

|= FOR i= 0 to 8:
|= L_work[i] = 0;
== FOR k = 0 to 8-i:
== L_work[i] = L_add( L_work[i], L_mult( aav1[k], aav1[k+i] ) );
== NEXT k:
|= NEXT i:

IF ( L_work[0] == 0 ) THEN normrav1 =0;
ELSE normrav1 = norm( L_work[0] );

|= FOR i= 0 to 8:
|= rav1[i] = ( L_work[i] << normrav1 ) >> 16;
|= NEXT i:

```

Keep the normrav1 for use in subclause 3.4 and 3.6.

## 3.4 Spectral comparison

This subclause computes the variable stat needed for the threshold adaptation. It uses the array L\_av0[0..8] computed in subclause 3.2 and the array rav1[0..8] computed in subclause 3.3.3.

### Re-normalize L\_av0[0..8]:

```

IF ( L_av0[0] == 0 ) THEN
    FOR i = 0 to 8:
        sav0[i] = 4095;
    NEXT i:
ELSE
    shift = norm( L_av0[0] );
    = FOR i = 0 to 8:
    = sav0[i] = ( L_av0[i] << shift-3 ) >> 16;
    = NEXT i:

```

### Compute partial $\Sigma$ of dm:

```

L_  $\Sigma$  p = 0;
|= FOR i = 1 to 8:
|= L_  $\Sigma$  p = L_add( L_  $\Sigma$  p, L_mult( rav1[i], sav0[i] ) );
|= NEXT i:

```

### Compute the division of partial $\Sigma$ by sav0[0]:

```

IF ( L_  $\Sigma$  p < 0 ) THEN L_temp = L_sub( 0, L_  $\Sigma$  p );
ELSE L_temp = L_  $\Sigma$  p;

IF ( L_temp == 0 ) THEN
    L_dm = 0;
    shift = 0;
ELSE
    sav0[0] = sav0[0] << 3;
    shift = norm( L_temp );
    temp = ( L_temp << shift ) >> 16;
    IF ( sav0[0] >= temp ) THEN
        divshift = 0;
        temp = div( temp, sav0[0] );
    ELSE
        divshift = 1;
        temp = sub( temp, sav0[0] );
        temp = div( temp, sav0[0] );

    IF( divshift == 1 ) THEN L_dm = 32768;
    ELSE L_dm = 0;

    L_dm = L_add( L_dm, temp ) << 1;
    IF( L_  $\Sigma$  p < 0 ) THEN L_dm = L_sub( 0, L_dm );

```

### Re-normalization and final computation of L\_dm:

```

L_dm = ( L_dm << 14 );
L_dm = L_dm >> shift;
L_dm = L_add( L_dm, ( ravl[0] << 11 ) );
L_dm = L_dm >> normrav1;

```

#### Compute the difference and save L\_dm:

```

L_temp = L_sub( L_dm, L_lastdm );
L_lastdm = L_dm;
IF ( L_temp < 0 ) THEN L_temp = L_sub( 0, L_temp );
L_temp = L_sub( L_temp, 3277 );

```

#### Evaluation of the stat flag:

```

IF ( L_temp < 0 ) THEN stat = 1;
ELSE stat = 0;

```

## 3.5 Periodicity detection

This subclause just sets the ptch flag needed for the threshold adaptation.

```

temp = add( oldlagcount, veryoldlagcount );
IF ( temp >= 4 ) THEN ptch = 1;
ELSE ptch = 0;

```

## 3.6 Threshold adaptation

This subclause uses the variables e\_pvad, m\_pvad, e\_acf0 and m\_acf0 computed in subclause 3.1. It also uses the flags stat (see subclause 3.4) and ptch (see subclause 3.5). It follows the flowchart represented on figure 2.2.

Some constants, represented by a floating point format, are needed and a symbolic name (in capital letter) for their exponent and mantissa is used; table 3.2 lists all these constants with the symbolic names associated and their numerical constant values.

**Table 3.2: List of constants**

Constant	Exponent	Mantissa
pth	E_PTH = 19	M_PTH = 18 750
margin	E_MARGIN = 27	M_MARGIN = 19 531
plev	E_PLEV = 20	M_PLEV = 25 000

NOTE: Floating point representation of constants used in subclause 3.6:

```

pth = 2(E_PTH)x(M_PTH/32768).
margin= 2(E_MARGIN)x(M_MARGIN/32768).
plev = 2(E_PLEV)x(M_PLEV/32768).

```

#### Test if acf0 < pth; if yes set thvad to plev:

```

comp = 0;
IF ( e_acf0 < E_PTH ) THEN comp = 1;
IF ( e_acf0 == E_PTH ) THEN IF ( m_acf0 < M_PTH ) THEN comp =1;
IF ( comp == 1 ) THEN
    | e_thvad = E_PLEV;
    | m_thvad = M_PLEV;
    | EXIT; /continue with subclause 3.7/

```

#### Test if an adaptation is needed:

```

comp = 0;
IF ( ptch == 1 ) THEN comp = 1;
IF ( stat == 0 ) THEN comp = 1;
IF ( tone == 1 ) THEN comp = 1;
IF ( comp == 1 ) THEN
    | adaptcount = 0;

```

```
| EXIT; /continue with subclause 3.7/
```

### Incrementation of adaptcount:

```
adaptcount = add( adaptcount, 1 );
IF ( adaptcount <= 8 ) THEN EXIT; /continue with subclause 3.7/
```

### Computation of thvad-(thvad/dec):

```
m_thvad = sub( m_thvad, (m_thvad >> 5 ) );
IF ( m_thvad < 16384 ) THEN
    | m_thvad = m_thvad << 1;
    | e_thvad = sub( e_thvad, 1 );
```

### Computation of pvad\*fac:

```
L_temp = L_add( m_pvad, m_pvad );
L_temp = L_add( L_temp, m_pvad );
L_temp = L_temp >> 1;
e_temp = add( e_pvad, 1 );
IF ( L_temp > 32767 ) THEN
    | L_temp = L_temp >> 1;
    | e_temp = add( e_temp, 1 );
m_temp = L_temp;
```

### Test if thvad < pvad\*fac:

```
comp = 0;
IF ( e_thvad < e_temp ) THEN comp = 1;
IF ( e_thvad == e_temp ) THEN IF ( m_thvad < m_temp ) THEN comp = 1;
```

### Computation of minimum (thvad+(thvad/inc), pvad\*fac) if comp = 1:

```
IF ( comp == 1 ) THEN
    | Compute thvad +(thvad/inc).
    | L_temp = L_add( m_thvad, (m_thvad >> 4 ) );
    | IF ( L_temp > 32767 ) THEN
    |     | m_thvad = L_temp >> 1;
    |     | e_thvad = add( e_thvad, 1 );
    | ELSE m_thvad = L_temp;
    | comp2 = 0;
    | IF ( e_temp < e_thvad ) THEN comp2 = 1;
    | IF ( e_temp == e_thvad ) THEN IF ( m_temp < m_thvad ) THEN comp2 = 1;
    | IF ( comp2 == 1 ) THEN
    |     | e_thvad = e_temp;
    |     | m_thvad = m_temp;
```

### Computation of pvad + margin:

```
IF ( e_pvad == E_MARGIN ) THEN
    | L_temp = L_add( m_pvad, M_MARGIN );
    | m_temp = L_temp >> 1;
    | e_temp = add( e_pvad, 1 );
ELSE
    | IF ( e_pvad > E_MARGIN ) THEN
    |     | temp = sub( e_pvad, E_MARGIN );
    |     | temp = M_MARGIN >> temp;
    |     | L_temp = L_add( m_pvad, temp );
    |     | IF ( L_temp > 32767 ) THEN
    |         | e_temp = add( e_pvad, 1 );
    |         | m_temp = L_temp >> 1;
    |     | ELSE
    |         | e_temp = e_pvad;
    |         | m_temp = L_temp;
    | ELSE
    |     | temp = sub( E_MARGIN, e_pvad );
    |     | temp = m_pvad >> temp;
    |     | L_temp = L_add( M_MARGIN, temp );
    |     | IF ( L_temp > 32767 ) THEN
    |         | e_temp = add( E_MARGIN, 1 );
    |         | m_temp = L_temp >> 1;
    |     | ELSE
    |         | e_temp = E_MARGIN;
    |         | m_temp = L_temp;
```

**Test if thvad > pvad + margin:**

```

comp = 0;
IF ( e_thvad > e_temp ) THEN comp = 1;
IF ( e_thvad == e_temp ) THEN IF ( m_thvad > m_temp ) THEN comp =1;

IF ( comp == 1 ) THEN
    | e_thvad = e_temp;
    | m_thvad = m_temp;

```

**Initialize new rvad[0..8] in memory:**

```

normrvad = normrav1;

| = FOR i = 0 to 8:
| = rvad[i] = rav1[i];
| = NEXT i:

```

**Set adaptcount to adp + 1:**

```

adaptcount = 9;

```

### 3.7 VAD decision

This subclause only outputs the result of the comparison between pvad and thvad using the pseudo-floating point representation of thvad and pvad. The values e\_pvad and m\_pvad are computed in subclause 3.1 and the values e\_thvad and m\_thvad are computed in subclause 3.6.

```

vvad = 0;
IF ( e_pvad > e_thvad ) THEN vvad = 1;
IF ( e_pvad == e_thvad ) THEN IF ( m_pvad > m_thvad ) THEN vvad =1;

```

### 3.8 VAD hangover addition

This subclause finally sets the vad decision for the current frame to be processed.

```

IF ( vvad == 1 ) THEN burstcount = add( burstcount, 1 );
ELSE burstcount = 0;

IF ( burstcount >= 3 ) THEN
    | hangcount = 5;
    | burstcount = 3;

vad = vvad;
IF ( hangcount >= 0 ) THEN
    | vad = 1;
    | hangcount = sub( hangcount, 1 );

```

### 3.9 Periodicity updating

This subclause must be delayed until the LTP lags are computed by the RPE-LTP algorithm. The LTP lags called Nc in the speech encoder are renamed lags[0..3] (index 0 for the first sub-segment of the frame, 1 for the second and so on).

**Loop on sub-segments for the frame:**

```

lagcount = 0;

| = FOR i = 0 to 3:
| = Search the maximum and minimum of consecutive lags.
| = IF ( oldlag > lags[i] ) THEN
| =
| = | minlag = lags[i];
| = | maxlag = oldlag;
| = ELSE
| = | minlag = oldlag;
| = | maxlag = lags[i] ;
| =
| = Compute smallag (modulo operation not defined):
| =

```

```

= smallag = maxlag;
== | FOR j = 0 to 2:
== |   IF (smallag >= minlag) THEN smallag =sub( smallag, minlag);
== |   NEXT j;
=
= Minimum of smallag and minlag - smallag:
=
= temp = sub( minlag, smallag );
= IF ( temp < smallag ) THEN smallag = temp;
= IF ( smallag < 2 ) THEN lagcount = add( lagcount, 1 );
= Save the current LTP lag.
= oldlag = lags[i];
= NEXT i:

```

#### Update the veryoldlagcount and oldlagcount:

```

veryoldlagcount = oldlagcount;
oldlagcount     = lagcount;

```

## 3.10 Tone detection

This subclause computes the tone variable needed for the threshold adaptation. Tone is only calculated for the VAD in the downlink. In the uplink VAD tone=0.

To reduce delay, this subclause should be calculated after the processing of the current speech encoder frame.

### 3.10.1 Windowing

This subclause applies a Hanning window to the input frame sof[0..159] to form the output frame sofh[0..159]. The input frame is the current offset compensated signal frame calculated in the RPE-LTP codec. The array of constants hann[i] is defined in table 3.2.

#### Multiply signal frame by Hanning window :

```

== FOR i = 0 to 79:
|   sofh[i] = mult_r( sof[i], hann[i] );
|   sofh[159-i] = mult_r( sof[159-i], hann[i] );
== NEXT i;

```

### 3.10.2 Auto-correlation

This subclause computes the auto-correlation vector L\_acfh[0..5] from the windowed input frame sofh[0..159]. The input frame must be scaled in order to avoid an overflow situation. This subclause is identical to the one used in the RPE-LTP algorithm, with the exception that only five auto-correlation values are calculated.

#### Dynamic scaling of the array sofh[0..159]:

##### Search for the maximum:

```

smax = 0;

== FOR k = 0 to 159:
|   temp = abs( sofh[k] );
|   IF ( temp > smax ) THEN smax = temp;
== NEXT k;

```

##### Computation of the scaling factor:

```

IF ( smax == 0 ) THEN scalauto = 0;
ELSE scalauto = sub( 4, norm( smax << 16));

```

##### Scaling of the array sofh[0..159]:

```

IF ( scalauto > 0 ) THEN
|   temp = 16384 >> sub( scalauto,1);
|   == FOR k = 0 to 159:
|   |   sofh[k] = mult_r( sofh[k], temp);
|   == NEXT k:

```



**Compute the L\_ACF[.]:**

```

== FOR k=0 to 4:
    L_acfh[k] = 0;
==== FOR i=k to 159:
    L_temp = L_mult( sofh[i], sofh[i-k] );
    L_acfh[k] = L_add( L_acfh[k], L_temp );
==== NEXT i:
== NEXT k:

```

**3.10.3 Computation of the reflection coefficients**

This subclause calculates the reflection coefficients rc[1..4] from the input array L\_acfh[0..4]. This procedure is identical to the one in subclause 3.3.1 and the RPE-LTP codec, with the exception that only four reflection coefficients are calculated.

**Schur recursion with 16 bits arithmetic:**

```

IF( L_acfh[0] == 0 ) THEN
    == FOR i = 1 to 4:
        rc[i] = 0;
    == NEXT i:
    EXIT; /continue with subclause 3.10.4/
temp = norm( L_acfh[0] );
== FOR k=0 to 4:
    sacf[k] = ( L_acfh[k] << temp ) >> 16;
== NEXT k:

```

**Initialize array P[.] and K[.] for the recursion:**

```

== FOR i=1 to 3:
    K[5-i] = sacf[i];
== NEXT i:

== FOR i=0 to 4:
    P[i] = sacf[i];
== NEXT i:

```

**Compute reflection coefficients:**

```

== FOR n=1 to 4:
    IF( P[0] < abs( P[1] ) ) THEN
        == FOR i = n to 4:
            rc[i] = 0;
        == NEXT i:
        EXIT; /continue with subclause 3.10.4/
    rc[n] = div( abs( P[1] ), P[0] );
    IF ( P[1] > 0 ) THEN rc[n] = sub( 0, rc[n] );
    IF ( n == 4 ) THEN EXIT; /continue with subclause 3.10.4/

```

**Schur recursion:**

```

    P[0] = add( P[0], mult_r( P[1], rc[n] ) );
==== FOR m=1 to 4-n:
    P[m] = add( P[m+1], mult_r( K[5-m], rc[n] ) );
    K[5-m] = add( K[5-m], mult_r( P[m+1], rc[n] ) );
==== NEXT m:
== NEXT n:

```

**3.10.4 Filter coefficient calculation**

This subclause calculates the direct form filter coefficients a[1..2] from the reflection coefficients rc[1..4].

**Step-up procedure to obtain the a[1..2]:**

```

temp = rc[1] >> 2;
a[1] = add( temp, mult_r( rc[2], temp ) );
a[2] = rc[2] >> 2;

```

### 3.10.5 Pole Frequency Test

This subclause uses the direct form filter coefficients  $a[1..2]$  to determine the pole frequency of the second order LPC analysis. If the pole frequency is less than 385 Hz tone is set to 0 and clause 3 terminates.

```
L_den = L_mult ( a[1], a[1] );
L_temp = a[2] << 16;
L_num = L_sub ( L_temp, L_den );
```

**If pole is not complex then exit :**

```
IF ( L_num <= 0 ) THEN
    | tone = 0;
    | EXIT; /clause 3 complete/
```

**If pole frequency is less than 385 Hz then exit :**

```
IF ( a[1] < 0 ) THEN
    | temp = L_den >> 16;
    | L_den = L_mult ( temp, 3189 );
    | L_temp = L_sub ( L_num, L_den );
    | IF ( L_temp < 0 ) THEN
        | tone = 0;
        | EXIT; /clause 3 complete/
```

### 3.10.6 Prediction gain test

This subclause uses the reflection coefficients  $rc[1..4]$  to calculate the prediction gain. If the prediction gain is greater than 13,5 dB then tone is set to 1 otherwise tone is set to 0.

**Calculate normalized prediction error :**

```
prederr = 32767;
== FOR i=1 to 4
    | temp = mult ( rc[i], rc[i] );
    | temp = sub ( 32767, temp );
    | prederr = mult( prederr, temp );
== NEXT i;
```

**Test if prediction error is smaller than threshold :**

```
temp = sub ( prederr, 1464 );
IF ( temp < 0 ) THEN tone = 1;
ELSE tone = 0;
```

Table 3.2: Values of the Hanning window array hann[i].

i	hann	i	hann	i	hann	i	hann
0	0	20	4856	40	16545	60	28139
1	12	21	5325	41	17192	61	28581
2	51	22	5811	42	17838	62	29003
3	114	23	6314	43	18482	63	29406
4	204	24	6832	44	19122	64	29789
5	318	25	7365	45	19758	65	30151
6	458	26	7913	46	20389	66	30491
7	622	27	8473	47	21014	67	30809
8	811	28	9046	48	21631	68	31105
9	1025	29	9631	49	22240	69	31377
10	1262	30	10226	50	22840	70	31626
11	1523	31	10831	51	23430	71	31852
12	1807	32	11444	52	24009	72	32053
13	2114	33	12065	53	24575	73	32230
14	2444	34	12693	54	25130	74	32382
15	2795	35	13326	55	25670	75	32509
16	3167	36	13964	56	26196	76	32611
17	3560	37	14607	57	26707	77	32688
18	3972	38	15251	58	27201	78	32739
19	4405	39	15898	59	27679	79	32764

## 4 Digital test sequences

This clause provides information on the digital test sequences that have been designed to help the verification of implementations of the Voice Activity Detector. Copies of these sequences are available (see clause A.2).

### 4.1 Test configuration

The VAD must be tested in conjunction with the speech encoder defined in GSM 06.10. The test configuration is shown in figure 4.1. The input signal to the speech encoder is the sop[...] signal as defined in GSM 06.10 table 5.1. The relevant parameters produced by the speech encoder are input to the VAD algorithm to produce the VAD output. This output has to be checked against some reference files.

The file format of the encoder output parameters given in GSM 06.10 table 5.1 is extended to carry the VAD information.

The VAD information is placed in the unused bit 15 (MSB) of the first encoded parameter:

```
LAR(1): bit 15 = 1 if VAD on
         bit 15 = 0 if VAD off
```

Furthermore, in order to facilitate approval testing over the air interface, the SP flag generated by the TX DTX handler (see GSM 06.31) on the basis of the VAD flag is placed in the MSB position of the second encoded parameter:

```
LAR(2): bit 15 = 1 if SP on
         bit 15 = 0 if SP off
```

The output file will also contain the SID codeword and the comfort noise parameters as described in GSM 06.12 and GSM 06.31.

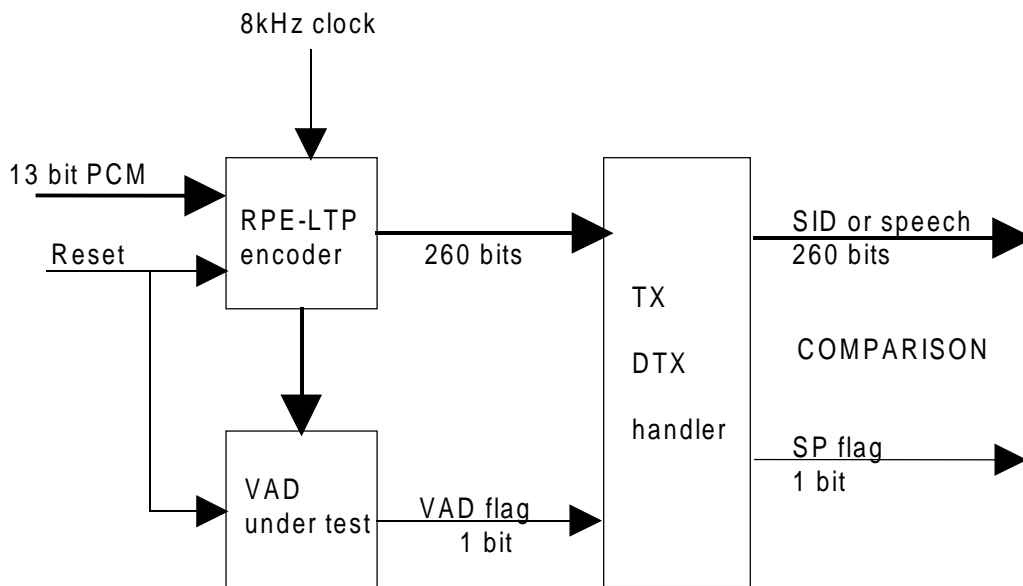

Figure 4.1: VAD test configuration

## 4.2 Test sequences

The test sequences are described in detail in clause A.2.

---

## Annex A (informative):

### A.1 Simplified block filtering operation

Consider an 8th order transversal filter with filter coefficients  $a_0..a_8$ , through which a signal is being passed, the output of the filter being:

$$s'(n) = -\sum_{i=0}^{8} a_i s(n-i) \quad (1)$$

If we apply block filtering over 20 ms segments, then this equation becomes:

$$s'(n) = -\sum_{i=0}^{8} a_i s(n-i) \quad ; 0 \leq n-i \leq 159 \quad ; 0 \leq n \leq 167 \quad (2)$$

If the energy of the filtered signal is then obtained for every 20 ms segment, the equation for this is:

$$P_{vad} = \sum_{n=0}^{167} \left[ -\sum_{i=0}^{8} a_i s(n-i) \right]^2 \quad ; 0 \leq n-i \leq 159 \quad (3)$$

We know that (see GSM 06.10, subclause 3.1.4):

$$acf_i = \sum_{n=0}^{159} s_n s_{n-i} \quad ; 0 \leq n-i \leq 159 \quad ; i = 0..8 \quad (4)$$

If equation (3) is expanded and  $acf_0..acf_8$  are substituted for  $s_n$  then we arrive at the equations:

$$P_{vad} = r_0 acf_0 + 2 \sum_{i=1}^{8} r_i acf_i \quad (5)$$

Where:

$$r_i = \sum_{k=0}^{8-i} a_k a_{k+i} \quad ; i=0..8 \quad (6)$$

---

## A.2 Description of digital test sequences

### A.2.1 Test sequences

The VAD algorithm uses results from the full rate speech encoder defined in GSM 06.10. In the testing of the VAD, it is assumed that the relevant speech encoder functions have been verified by the test sequences defined in GSM 06.10.

The five types of input sequences are briefly described below.

#### Spectral comparison

The two kinds of statements of the spectral comparison algorithm (subclause 3.4), arithmetic statements and control statements, are tested by separate test sequences.

Arithmetic statements:

spec\_a1.\*

spec\_a2.\*

Control statements

spec\_c1.\*

spec\_c2.\*

spec\_c3.\*

spec\_c4.\*

#### Threshold adaptation

There are two types of tests to verify the threshold adaptation described in subclause 3.6:

adapt\_i1.\*

adapt\_i2.\*

The initial test sequences test the acf0 and VAD decision. A fault in the VAD decision will cause all the other sequences to fail, so it is recommended that this test is run before all other tests.

adapt\_m1.\*

adapt\_m2.\*

The main test sequences will check the basic threshold adaptation mechanism.

#### Periodicity detection

pitch1.\*

pitch2.\*

These sequences check the periodicity detection algorithm described in subclause 3.5.

#### Tone detection

The tone detector test sequences are only required for downlink VAD implementations. There are three types of test to verify the tone detection algorithm described in subclause 3.10. The first test sequence tests the operation of the tone detector by means of a frequency sweep:

freq\_sw.\*

The following test sequences test the prediction gain calculation within the tone detector:

pred1.\*

pred2.\*

The following sequences test the second order pole frequency calculation within the tone detector:

pole1.\*

pole2.\*

#### "Safety" and initialization

safety.\*

This sequence checks that safety tests have been implemented to prevent zero values being passed to the norm function. It checks the functions described in the Adaptive Filtering and Energy Computation subclause (subclause 3.1), and the Predictor Values Computation (subclause 3.3). This sequence also checks the initialization of thvad and the rvad array.

### Real speech

good\_sp.\*

bad\_sp.\*

Because the test sequences cannot be guaranteed to find every possible error, there is a small possibility that an implementation of the correct output for test sequences, but fail with real speech. Because of this, an extra set of sequences are included that consist of barely detectable speech and very clean speech.

There are 3 different file extensions:

\*.inp: speech encoder input sequences, binary files

\*.vad: output flag of the VAD algorithm, ASCII files

\*.cod: TX DTX handler output sequences, binary files for comparison with VAD/DTX handler output.

The \*.cod files contain speech coder output information in the format described in clause 4.

It should be noted that there is no requirement in GSM 06.12 for a bit exact implementation of the averaging procedure to calculate the "LAR" and "xmax" parameters in the SID frames. Different implementations are allowed.

The algorithms used for the calculation of the LAR and xmax parameters of the SID frames are therefore reproduced below:

#### **LAR averaging:**

```

FOR i = 1 to 8:
  L_Temp = 2; /* const. for rounding*/
  FOR n = 1 to 4:
    L_Temp1 = LAR[j-n](i); /*conversion 16 --> 32 bit*/
    L_Temp = L_Add( L_Temp , L_Temp1 );
  NEXT n
  L_Temp = L_temp >> 2;
  mean (LAR(i)) = L_Temp; /*conversion 32 --> 16 bit*/
NEXT i;

```

#### **xmax averaging**

```

L_Temp = 8; /* const. for rounding*/

FOR n = 1 to 4:
  FOR i = 1 to 4:
    L_Temp1 = xmax[j-n](i); /*conversion 16 --> 32 bit*/
    L_Temp = L_Add( L_Temp , L_Temp1 );
  NEXT i
NEXT n

L_Temp = L_Temp >> 4;

mean (xmax) = L_Temp; /*conversion 32 --> 16 bit*/

```

## A.2.2 File format description

All the \*.inp and \*.cod files are written in binary using 16 bit words, while all \*.vad files are written in ASCII format. The sizes of the files are shown in table A.2.1, A.2.2 and A.2.3. The detailed format of the \*.inp and \*.cod files is in accordance with the descriptions given in GSM 06.10 clause 5.

**Table A.2.1: File sizes for \*.inp extension files**

<b>File:</b>	<b>Frames:</b>	<b>Size in bytes:</b>
spec_a1.inp	22	7 040
spec_a2.inp	22	7 040
spec_c1.inp	48	15 360
spec_c2.inp	48	15 360
spec_c3.inp	48	15 360
spec_c4.inp	48	15 360
adapt_i1.inp	67	21 440
adapt_i2.inp	48	15 360
adapt_m1.inp	403	128 960
adapt_m2.inp	376	120 320
pitch1.inp	35	11 200
pitch2.inp	35	11 200
freq_sw.inp	560	179 200
pred1.inp	126	40 320
pred2.inp	126	40 320
pole1.inp	97	31 040
pole2.inp	42	13 440
safety.inp	5	16 00
good_sp.inp	312	99 840
bad_sp.inp	312	99 840

**Table A.2.2: File sizes for \*.cod extension files**

<b>File:</b>	<b>Frames:</b>	<b>Size in bytes:</b>
spec_a1.cod	22	3 344
spec_a2.cod	22	3 344
spec_c1.cod	48	7 296
spec_c2.cod	48	7 296
spec_c3.cod	48	7 296
spec_c4.cod	48	7 296
adapt_i1.cod	67	10 184
adapt_i2.cod	48	7 296
adapt_m1.cod	403	61 256
adapt_m2.cod	376	57 152
pitch1.cod	35	5 320
pitch2.cod	35	5 320
freq_sw.cod	560	85 120
pred1.cod	126	19 152
pred2.cod	126	19 152
pole1.cod	97	14 744
pole2.cod	42	6 384
safety.cod	5	760
good_sp.cod	312	47 424
bad_sp.cod	312	47 424



Table A.2.3: File sizes for \*.vad extension files

File:	Frames:	Size in bytes:
spec_a1.vad	22	88
spec_a2.vad	22	88
spec_c1.vad	48	192
spec_c2.vad	48	192
spec_c3.vad	48	192
spec_c4.vad	48	192
adapt_i1.vad	67	268
adapt_i2.vad	48	192
adapt_m1.vad	403	1 612
adapt_m2.vad	376	1504
pitch1.vad	35	140
pitch2.vad	35	140
freq_sw.inp	560	2 240
pred1.vad	126	504
pred2.vad	126	504
pole1.vad	97	388
pole2.vad	42	168
safety.vad	5	20
good_sp.vad	312	1 248
bad_sp.vad	312	1 248

## A.3 VAD performance

In optimizing a VAD a difficult trade-off has to be made between speech clipping which reduces the subjective performance of the system, and the average activity factor. The benefit of DTX is increased as the average activity factor is reduced. However, in general, a reduction of the activity will be associated with a greater risk for audible speech clipping.

In the optimization process, great emphasis has been placed on avoiding unnecessary speech clipping. However, it has been found that a VAD with virtually no audible clipping would result in a very high activity and very little DTX advantage.

The VAD specified in this technical specification introduces audible and possibly objectionable clipping in certain cases, mainly with low input levels. However, a comprehensive evaluation programme consisting of about 600 individual conversations conducted in a wide range of realistic conditions, it was found that about 90% of the conversations were free from objectionable clipping.

The voice activity performance of the VAD is summarized in table A.3.1. The activity figures are averages of a large number of conversations covering factors like different talkers, noise characteristics and locations. It should be noted that the actual activity of a particular talker in a specific conversation may vary considerably relative to the averages given. This is due both to the variation in talker behaviour as well as to the level dependency of the VAD (the channel activity has been found to decrease by about 0,5 points of percentage per dB level reduction). However, as mentioned above, a decreased speech input level increases the risk of objectionable speech clipping.

All the values given are activity figures, i.e. the % of time the radio channel has to be on.

Table A.3.1: Summary of channel activity

Telephone instrument	Situation	Typical channel activity factor:
Handset	Quiet location	55%
Handset	Moderate office noise with voice interference	60%
Handset	Strong voice interference (e.g. airport/railway station)	65-70%
Handsfree/handset	Variable vehicle noise	60%

## A.4 Pole frequency calculation

This annex describes the algorithm used to determine whether the pole frequency for a second order analysis of the signal frame is less than 385 Hz.

The filter coefficients for a second order synthesis filter are calculated from the first two unquantized reflection coefficients  $rc[1..2]$  obtained from the speech encoder. This is done using the routine described in subclause 3.10.4. If the filter coefficients  $a[0..2]$  are defined such that the synthesis filter response is given by:

$$H(z) = 1 / (a[0] + a[1]z^{-1} + a[2]z^{-2}) \quad (1)$$

Then the positions of the poles in the Z-plane are given by the solutions to the following quadratic:

$$a[0]z^2 + a[1]z + a[2] = 0, \quad a[0] = 1 \quad (2)$$

The positions of the poles,  $z$ , are therefore:

$$z = re \pm j \cdot \sqrt{im}, \quad j^2 = -1 \quad (3)$$

where:

$$re = -a[1] / 2 \quad (4)$$

$$im = (4 \cdot a[2] - a[1]^2) / 4 \quad (5)$$

If  $im$  is negative then the poles lie on the real axis of the Z-plane and the signal is not a tone and the algorithm terminates. If  $re$  is negative then the poles lie in the left hand side of the Z-plane and the frequency is greater than 2 000 Hz and the prediction error test can be performed.

If  $im$  is positive and  $re$  is positive then the poles are complex and lie in the right hand side of the Z-plane and the frequency in Hz is related to  $re$  and  $im$  by the expression:

$$freq = \arctan(\sqrt{im}/re) * 4\,000 / \pi \quad (6)$$

Having ensured that both  $im$  and  $re$  are positive, the test for a dominant frequency less than 385 Hz can be derived by substituting Equations 4 and 5 into Equation 6 and re-arranging:

$$(4 \cdot a[2] - a[1]^2) / a[1]^2 < (\tan(\pi \cdot 385 / 4\,000))^2 \quad (7)$$

or

$$(4 \cdot a[2] - a[1]^2) / a[1]^2 < 0.0973 \quad (8)$$

If this test is true then the signal is not a tone and the algorithm terminates, otherwise the prediction error test is performed.

---

## Annex B (normative): Test sequences

The test vectors described in the present document are supplied in archive 8xo03000.ZIP which accompanies the present document. The files contained in this archive are listed in clause A.2.

The full rate test vectors apply to both GSM Phase 1 and Phase 2. However, the files pole1.\* pole2.\* pred1.\* pred2.\* and freq\_sw.\* are not required for Phase 1 (uplink and downlink) and Phase 2 uplink implementations.

---

## Annex C (informative): Change Request History

<b>Change history</b>					
<b>SMG No.</b>	<b>TDoc. No.</b>	<b>CR. No.</b>	<b>Section affected</b>	<b>New version</b>	<b>Subject/Comments</b>
SMG#09				4.0.5	ETSI Publication
SMG#17				4.2.1	ETSI Publication
SMG#23				4.3.1	ETSI Publication
SMG#23				5.0.3	Release 1996 version
SMG#27				6.0.0	Release 1997 version

---

# History

<b>Document history</b>			
Edition 1	December 1996	Unified Approval Procedure	UAP 61: 1996-12-16 to 1997-04-11
Edition 1	May 1997	Publication as ETS 300 965	
Edition 2	November 1997	One-step Approval Procedure	OAP 9813: 1997-11-28 to 1998-03-27
Edition 2	April 1998	Publication as ETS 300 965	
V6.0.0	January 1999	One-step Approval Procedure	OAP 9922: 1999-01-29 to 1999-05-28