

Draft **ETSI EN 300 964** V8.0.0 (2000-07)

European Standard (Telecommunications series)

**Digital cellular telecommunications system (Phase 2+);
Full rate speech;
Discontinuous Transmission (DTX)
for full rate speech traffic channels
(GSM 06.31 version 8.0.0 Release 1999)**

GSM®
GLOBAL SYSTEM FOR
MOBILE COMMUNICATIONS



Reference

REN/SMG-110631Q8

Keywords

Digital cellular telecommunications system,
Global System for Mobile communications (GSM)

ETSI

650 Route des Lucioles
F-06921 Sophia Antipolis Cedex - FRANCE

Tel.: +33 4 92 94 42 00 Fax: +33 4 93 65 47 16

Siret N° 348 623 562 00017 - NAF 742 C
Association à but non lucratif enregistrée à la
Sous-Préfecture de Grasse (06) N° 7803/88

Important notice

Individual copies of the present document can be downloaded from:

<http://www.etsi.org>

The present document may be made available in more than one electronic version or in print. In any case of existing or perceived difference in contents between such versions, the reference version is the Portable Document Format (PDF).

In case of dispute, the reference shall be the printing on ETSI printers of the PDF version kept on a specific network drive within ETSI Secretariat.

Users of the present document should be aware that the document may be subject to revision or change of status.

Information on the current status of this and other ETSI documents is available at <http://www.etsi.org/tb/status/>

If you find errors in the present document, send your comment to:

editor@etsi.fr

Copyright Notification

No part may be reproduced except as authorized by written permission.
The copyright and the foregoing restriction extend to reproduction in all media.

© European Telecommunications Standards Institute 2000.
All rights reserved.

Contents

Intellectual Property Rights	4
Foreword	4
1 Scope	5
2 References	5
3 Definitions and abbreviations	6
3.1 Definition of general terms	6
3.2 Definition of terms on the receive side	6
4 General	7
4.1 General organization	7
4.2 Naming convention	7
5 Transmit side	7
5.1 General operation	8
5.1.1 Functions of the TX DTX handler	8
5.1.2 Functions of the TX radio subsystem	10
6 Receive side	10
6.1 General operation	10
6.1.1 Functions of the RX Radio Subsystem	11
6.1.2 Functions of the RX DTX handler	11
Annex A (informative): Change Request History	12
History	13

Intellectual Property Rights

IPRs essential or potentially essential to the present document may have been declared to ETSI. The information pertaining to these essential IPRs, if any, is publicly available for **ETSI members and non-members**, and can be found in ETSI SR 000 314: *"Intellectual Property Rights (IPRs); Essential, or potentially Essential, IPRs notified to ETSI in respect of ETSI standards"*, which is available from the ETSI Secretariat. Latest updates are available on the ETSI Web server (<http://www.etsi.org/ipr>).

Pursuant to the ETSI IPR Policy, no investigation, including IPR searches, has been carried out by ETSI. No guarantee can be given as to the existence of other IPRs not referenced in ETSI SR 000 314 (or the updates on the ETSI Web server) which are, or may be, or may become, essential to the present document.

Foreword

This European Standard (Telecommunications series) has been produced by ETSI Technical Committee Special Mobile Group (SMG), and is now submitted for the ETSI standards One-step Approval Procedure.

The present document specifies the Discontinuous Transmission (DTX) for full rate speech traffic channel for the digital cellular telecommunications system.

The contents of the present document is subject to continuing work within SMG and may change following formal SMG approval. Should SMG modify the contents of the present document it will be re-released with an identifying change of release date and an increase in version number as follows:

Version 8.x.y

where:

- 8 indicates Release 1999 of GSM Phase 2+.
- x the second digit is incremented for all changes of substance, i.e. technical enhancements, corrections, updates, etc.
- y the third digit is incremented when editorial only changes have been incorporated in the specification.

Proposed national transposition dates	
Date of latest announcement of this EN (doa):	3 months after ETSI publication
Date of latest publication of new National Standard or endorsement of this EN (dop/e):	6 months after doa
Date of withdrawal of any conflicting National Standard (dow):	6 months after doa

1 Scope

The present document gives a description of the general baseband operation of full rate speech traffic channels in the transmitter and in the receiver of GSM Mobile Stations (MS)s and Base Station Systems (BSS)s during Discontinuous Transmission (DTX).

For clarity, the description is structured according the block diagrams in figures 1 and 4. Except in the case described next, this structure of distributing the various functions between system entities is not mandatory for implementation, as long as the operation on the air interface and on the speech decoder output remains the same.

In the case of BSSs where the speech transcoder is located remotely in the Base Station Controller (BSC), the implementation of the interfaces between the DTX Handlers and the Radio Subsystem (RSS) as described in the present document together with all their flags is mandatory, being a part of the A-bis- interface as described in GSM 08.60. In this case the various flags also serve to avoid additional delays.

The DTX functions described in the present document are mandatory for implementation in all GSM MSs. The receiver requirements are mandatory for implementation in all GSM BSSs, the transmitter requirements only for those where downlink DTX will be used.

DTX shall be in operation in GSM MSs if commanded so by the network, see GSM 04.08.

2 References

The following documents contain provisions which, through reference in this text, constitute provisions of the present document.

- References are either specific (identified by date of publication, edition number, version number, etc.) or non-specific.
- For a specific reference, subsequent revisions do not apply.
- For a non-specific reference, the latest version applies.
- A non-specific reference to an ETS shall also be taken to refer to later versions published as an EN with the same number.
- For this Release 1999 document, references to GSM documents are for Release 1999 versions (version 8.x.y).

- [1] GSM 01.04: "Digital cellular telecommunications system (Phase 2+); Abbreviations and acronyms".
- [2] GSM 04.08: "Digital cellular telecommunications system (Phase 2+); Mobile radio interface layer 3 specification".
- [3] GSM 05.03: "Digital cellular telecommunications system (Phase 2+); Channel coding".
- [4] GSM 05.05: "Digital cellular telecommunications system (Phase 2+); Radio transmission and reception".
- [5] GSM 05.08: "Digital cellular telecommunications system (Phase 2+); Radio subsystem link control".
- [6] GSM 06.01: "Digital cellular telecommunications system (Phase 2+); Full rate speech; Processing functions".
- [7] GSM 06.10: "Digital cellular telecommunications system (Phase 2+); Full rate speech; Transcoding".
- [8] GSM 06.11: "Digital cellular telecommunications system (Phase 2+); Full rate speech; Substitution and muting of lost frames for full rate speech channels".

- [9] GSM 06.12: "Digital cellular telecommunications system (Phase 2+); Full rate speech; Comfort noise aspect for full rate speech traffic channels".
- [10] GSM 06.32: "Digital cellular telecommunications system (Phase 2+); Voice Activity Detector (VAD)".
- [11] GSM 08.60: "Digital cellular telecommunications system (Phase 2+); Inband control of remote transcoders and rate adaptors for Enhanced Full Rate (EFR) and full rate traffic channels".

3 Definitions and abbreviations

Abbreviations used in the present document are listed in GSM 01.04.

3.1 Definition of general terms

frame: time interval of 20 msec. corresponding to the time segmentation of the full rate speech transcoder (GSM 06.10), also used as a short term for a traffic frame.

traffic frame: block of 260 information bits (see GSM 05.03) transmitted on the full rate speech traffic channel.

(SID) silence descriptor frame: frame characterized by the SID code word. It conveys information on the acoustic background noise.

SID code word: fixed bit pattern defined in GSM 06.12, for labelling a traffic frame as a SID frame.

SID field: bit positions defined in GSM 06.12, of the SID codeword within a SID frame.

speech frame: traffic frame that cannot be classified as a SID frame.

3.2 Definition of terms on the receive side

bad traffic frame: traffic frame flagged BFI=1 (Bad Frame Indication) by the Radio Subsystem.

good traffic frame: traffic frame flagged BFI=0 by the Radio Subsystem.

good speech frame: good traffic frame which is not an accepted SID frame.

accepted SID frame: traffic frame in which the SID field deviates in less than 16 bit positions from the SID code word (flag SID=2 or SID=1).

valid SID frame: good traffic frame in which the SID field deviates in less than 2 bit positions from the SID code word (flag SID=2). This frame is valid for updating of comfort noise parameters at any time.

invalid SID frame: accepted SID frame with BFI=1, or accepted SID frame with BFI=0, in which the SID field deviates in more than 1 bit position from the SID code word (flag SID=1). This frame is not valid for updating comfort noise parameters, but the frame conveys information that comfort noise generations should be started or continued.

unusable frame: bad traffic frame that is not an accepted SID frame.

lost SID frame: unusable frame received when the RX DTX Handler is generating comfort noise and a SID frame is expected (Time Alignment Flag, TAF=1).

lost speech frame: unusable frame received when the RX DTX Handler is passing on traffic frames directly to the speech decoder.

4 General

Discontinuous Transmission is a mechanism which allows the radio transmitter to be switched off most of the time during speech pauses for the following two purposes:

- to save power in the MS;
- to reduce the overall interference level on the air.

4.1 General organization

The overall DTX mechanism described in the present document requires the following functions:

- a Voice Activity Detector on the transmit side;
- evaluation of the background acoustic noise on the transmit side, in order to transmit characteristic parameters to the receive side;
- generation on the receive side of a similar noise, called comfort noise, during periods where the radio transmission is cut.

The Voice Activity Detector is defined in GSM 06.32 "Voice Activity Detector", the comfort noise functions in GSM 06.12 "Comfort Noise Aspects". Both are based partly on the speech transcoder and its internal variables, defined in GSM 06.10 "GSM Full Rate Speech Transcoding".

In addition to these functions, if the parameters arriving at the receive side are detected to be seriously corrupted by errors, the speech or comfort noise must be generated from substituted data in order to avoid seriously annoying effects for the listener. This function is defined in GSM 06.11 "Substitution and Muting of Lost Frames".

An overall description of the speech processing parts can be found in GSM 06.01 "Processing functions".

4.2 Naming convention

Clause 3 lists the definitions of terms relevant for the DTX functions, as used in this and the technical specifications mentioned above.

5 Transmit side

A block diagram of the transmit side DTX functions is shown in figure 1.

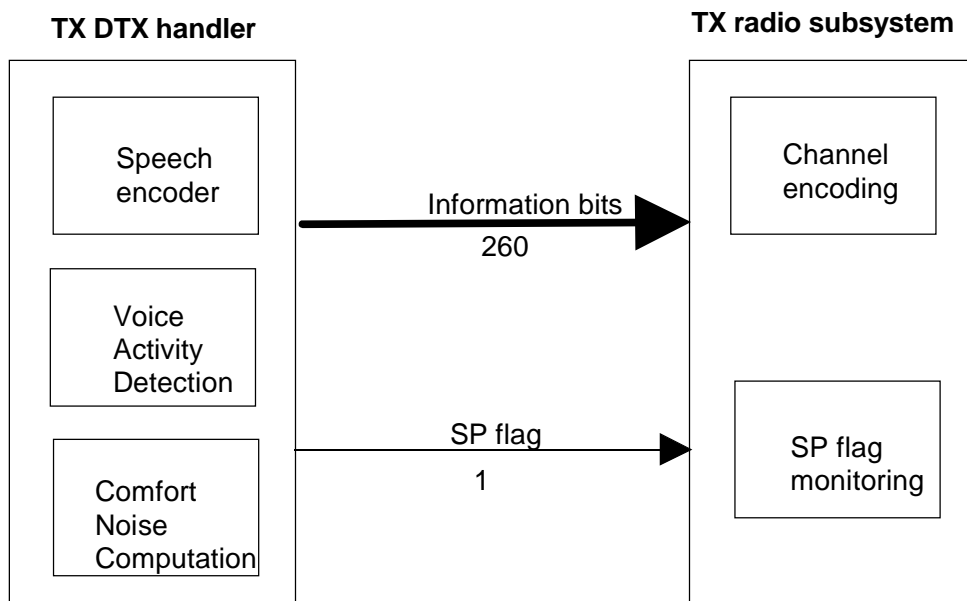

Figure 1: Block diagram of the transmit side DTX functions

5.1 General operation

The TX DTX Handler continuously passes traffic frames, individually marked by a flag SP, to the Radio Subsystem. This binary flag is redundant to the SID code word labelling. SP=1 indicates a speech frame, SP=0 a SID frame.

The scheduling of the frames for transmission on the air interface is controlled by the radio subsystem alone, on the basis of the SP flag as described next.

5.1.1 Functions of the TX DTX handler

To allow an exact verification of the TX DTX handler functions, all frames before the reset of the system have to be treated as if there would have been speech frames for an infinitely long time. Therefore, the first N frames after the reset are always marked with SP=1, even if VAD=0 (hangover period, see below).

The Voice Activity Detector must be operating all the time in order to assess whether the input signal contains speech or not. The output is a binary flag (VAD=1 or VAD=0, respectively) on a frame by frame basis (see GSM 06.32).

The VAD flag controls indirectly, via the TX DTX Handler operations described below, the overall DTX operation on the transmit side.

Whenever VAD=1, the speech encoder output frame shall be passed directly to the radio subsystem, marked with SP=1.

At the end of a speech burst (transition VAD=1 to VAD=0), it takes N+1 consecutive frames to make a new updated SID frame available (see GSM 06.12). Normally, the first N speech encoder output frames after the end of the speech burst shall therefore be passed directly to the radio subsystem, marked with SP=1 ("hangover period"). The first new SID frame is then passed to the RSS as frame N+1 after the end of the speech burst, marked with SP=0 (see figure 2).

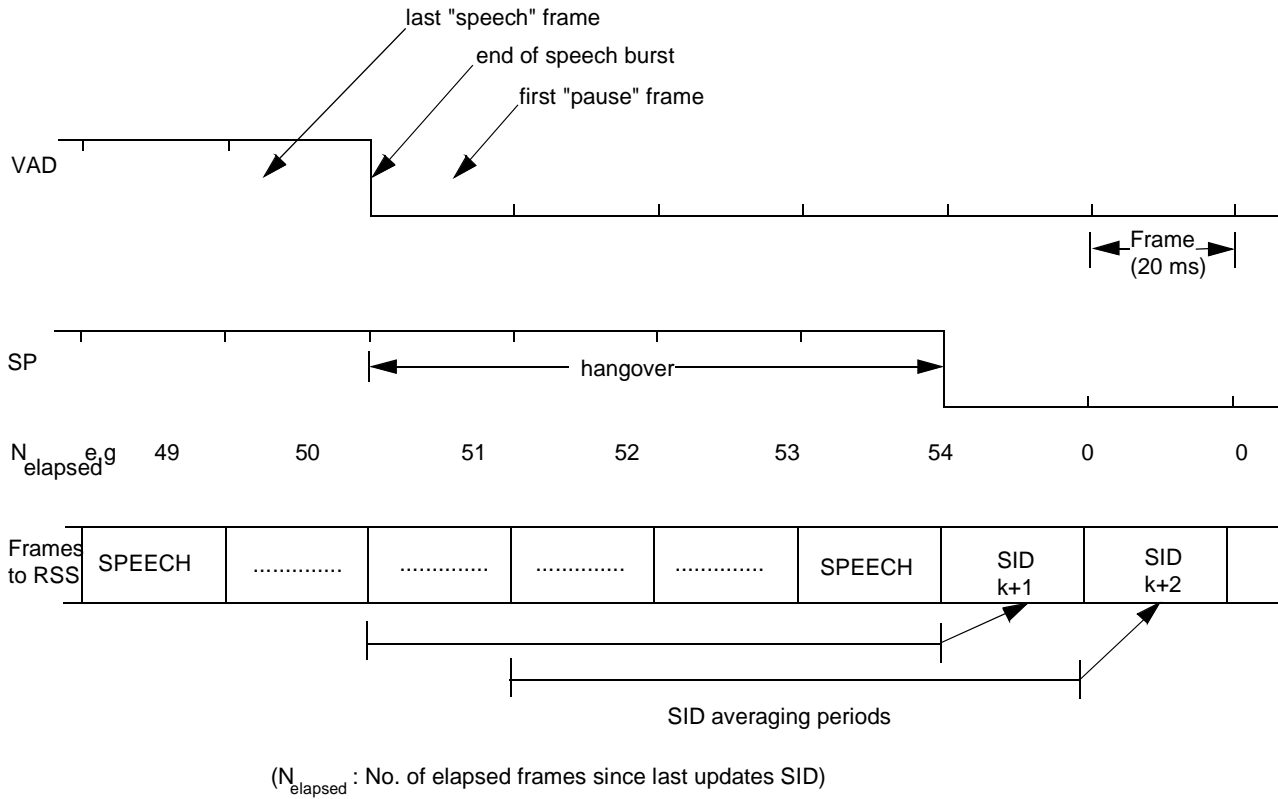

Figure 2: "Normal" hangover procedure (N_{elapsed} > 23)

If, however, at the end of the speech burst, less than 24 frames have elapsed since the last SID frame was computed and passed to the RSS, then this last SID frame shall repeatedly be passed to the RSS, until a new updated SID frame is available (N+1 consecutive frames marked with VAD=0). This reduces the activity on the air in cases where short background noise spikes are taken for speech, by avoiding the "hangover" waiting for the SID frame computation (see also figure 3: Note that figure 3 shows as example the longest possible speech burst without hangover).

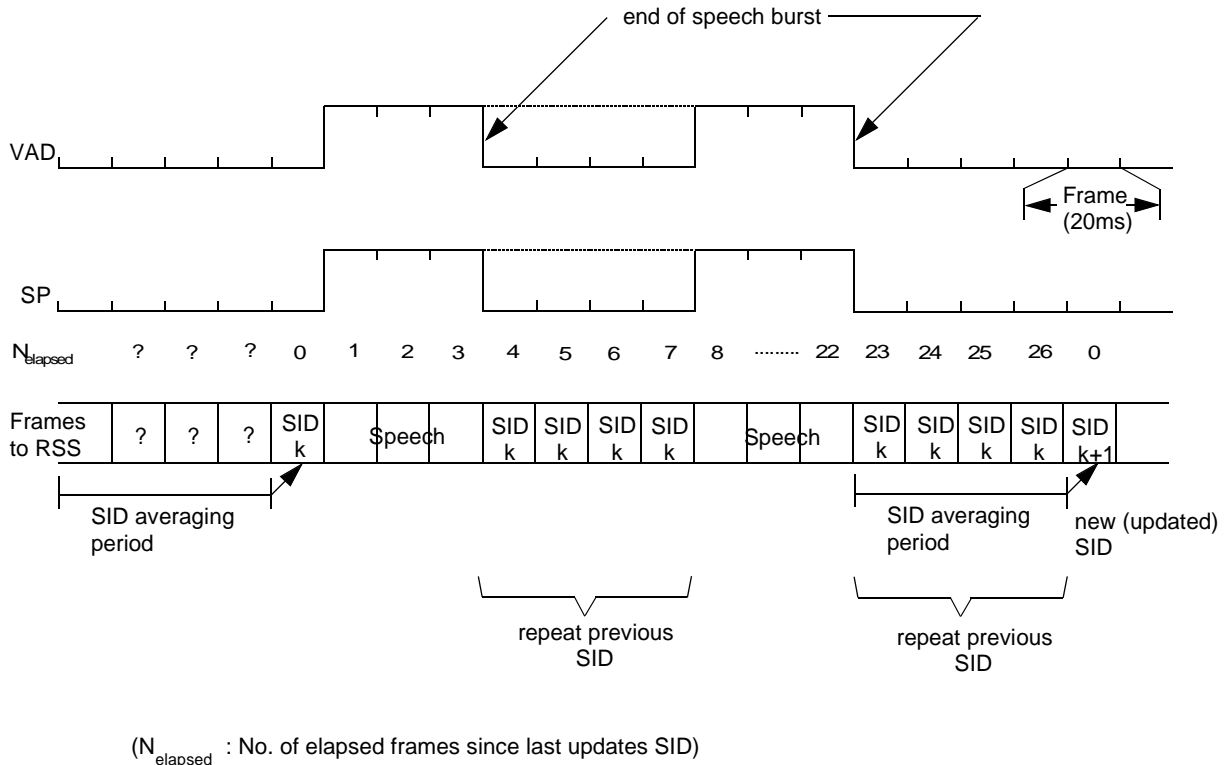

Figure 3: Handling of short speech bursts (N_{elapsed} < 24) (Example)

Once the first SID frame after the end of a speech burst has been computed and passed to the Radio Subsystem, the TX DTX Handler shall continuously compute and pass updated SID frames to the Radio Subsystem, marked with SP=0 as long as VAD remains VAD=0.

Consequently, the speech encoder must be operating all the time.

5.1.2 Functions of the TX radio subsystem

The following traffic frames shall be scheduled for transmission:

- 1) all frames marked with SP=1;
- 2) the first one with SP = 0 after one or more frames with SP=1;
- 3) those marked with SP=0 and aligned with the SACCH multiframe structure as described in GSM 05.08.

This has the overall function, that the radio transmission is cut after the transmission of a SID frame when the speaker stops talking. During speech pauses the transmission is resumed at regular intervals for transmission of one SID frame, in order to update the generated comfort noise on the receive side (and to improve the measurement of the link quality by the radio subsystem).

If a SID frame (SP=0), scheduled for transmission is stolen for signalling (FACCH) purposes, then the subsequent frame shall be scheduled for transmission instead.

6 Receive side

A block diagram of the receive side DTX functions is shown in figure 4.

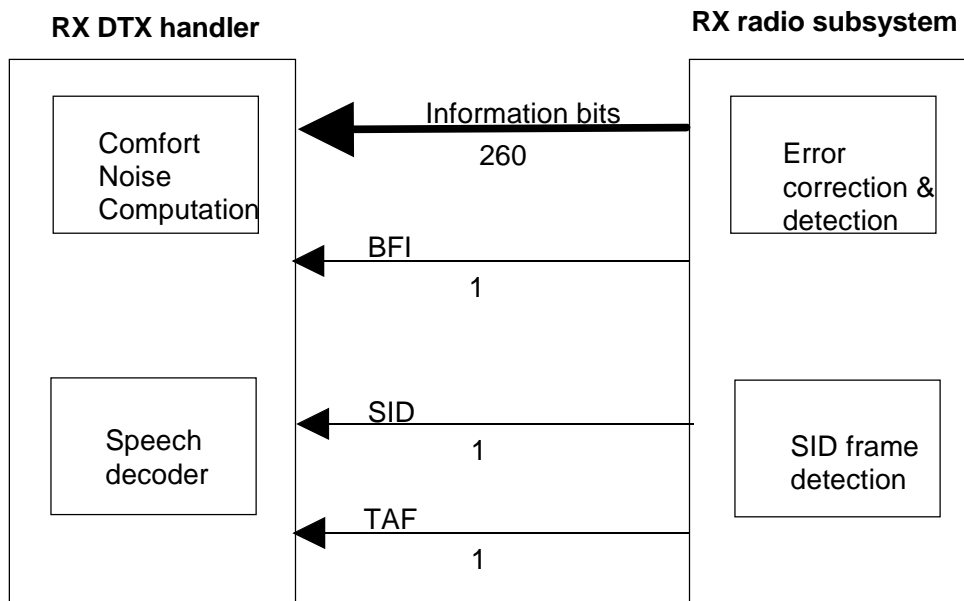

Figure 4: Block diagram of the receive side DTX functions

6.1 General operation

Whatever their context (speech, SID, FACCH or none), the Radio Subsystem continuously passes the received traffic frames to the RX DTX handler, individually marked by various pre-processing functions with 3 flags. These are the BFI, the SID and the TAF flags described below, which serve to classify the traffic frame according to the list of terms defined in clause 3. This classification, summarized in table 1 below, in turn allows the RX DTX Handler to determine in a simple way how the received frame is to be handled.

Table 1: Classification of traffic frames

BFI	SID		
	2	1	0
0	Valid SID frame	Invalid SID frame	Good speech frame
1			Unusable frame

6.1.1 Functions of the RX Radio Subsystem

The binary BFI flag (Bad Frame Indication, see also GSM 05.05) indicates whether the traffic frame is considered to contain meaningful information bits (BFI=0) or not (BFI=1). In the context of this technical specification, a FACCH frame is considered not to contain meaningful bits and must also be marked with BFI=1. The BFI flag must fulfil the performance requirements of GSM 05.05.

The ternary SID flag is the output of a SID frame detector, which compares bit by bit the relevant bits of the received traffic frame (the SID field) with the SID code word defined in GSM 06.12. The flag is coded as follows, where n designates the number of bit deviation:

- SID=2 when $n < 2$;
- SID=1 when $2 \leq n < 16$;
- SID=0 when $n \geq 16$.

The binary TAF flag (Time Alignment Flag) marks with TAF=1 those traffic frames that are aligned with the SACCH multiframe structure as described in the technical specifications referenced in subclause 5.1.2.

6.1.2 Functions of the RX DTX handler

The RX DTX Handler is responsible for the overall DTX operation on the receive side, which shall be as follows:

- whenever a good speech frame is detected, the DTX Handler shall pass it directly on to the speech decoder;
- when lost speech or lost SID frames are detected, the substitution and muting procedure defined in GSM 06.11 shall be applied;
- valid SID frames shall result in comfort noise generation, as defined in GSM 06.12, until the next SID frame is expected (TAF=1) or good speech frames are detected. During this period, the RX DTX handler shall ignore any unusable frames delivered by the Radio Subsystem;
- an invalid SID frame shall be substituted by the last valid SID frame and the procedure for valid SID frames be applied.

NOTE: If the first SID frame after a speech burst (a series of good speech frames) is invalid, then the comfort noise parameters can be taken from the last valid SID frame or from the last received good speech frame which, because of the VAD hangover time (see GSM 06.32), may be supposed to contain noise only.

Annex A (informative): Change Request History

Change history					
SMG No.	TDoc. No.	CR. No.	Section affected	New version	Subject/Comments
SMG#07				4.0.5	ETSI Publication
SMG#20				5.0.1	Release 1996 version
SMG#27				6.0.0	Release 1997 version
SMG#29				7.0.0	Release 1998 version
				7.0.1	Version update to 7.0.1 for Publication
SMG#31				8.0.0	Release 1999 version

History

Document history			
V8.0.0	July 2000	One-step Approval Procedure	OAP 20001103: 2000-07-05 to 2000-11-03