

Draft **ETSI EN 300 904** V7.0.1 (1999-07)

European Standard (Telecommunications series)

**Digital cellular telecommunications system (Phase 2+);
Bearer Services (BS) supported by a GSM
Public Land Mobile Network (PLMN)
(GSM 02.02 version 7.0.1 Release 1998)**



GSM®
GLOBAL SYSTEM FOR
MOBILE COMMUNICATIONS

ETSI 

Reference

DEN/SMG-010202Q7 (8dc03i0o.PDF)

Keywords

Digital cellular telecommunications system,
Global System for Mobile communications (GSM)

ETSI

Postal address

F-06921 Sophia Antipolis Cedex - FRANCE

Office address

650 Route des Lucioles - Sophia Antipolis
Valbonne - FRANCE
Tel.: +33 4 92 94 42 00 Fax: +33 4 93 65 47 16
Siret N° 348 623 562 00017 - NAF 742 C
Association à but non lucratif enregistrée à la
Sous-Préfecture de Grasse (06) N° 7803/88

Internet

secretariat@etsi.fr
Individual copies of this ETSI deliverable
can be downloaded from
<http://www.etsi.org>
If you find errors in the present document, send your
comment to: editor@etsi.fr

Copyright Notification

No part may be reproduced except as authorized by written permission.
The copyright and the foregoing restriction extend to reproduction in all media.

© European Telecommunications Standards Institute 1999.
All rights reserved.

Contents

Intellectual Property Rights.....	4
Foreword	4
0 Scope.....	5
0.1 References.....	5
0.2 Abbreviations.....	6
1 Framework for defining Bearer Services	6
2 Bearer Service categories.....	8
3 Bearer Services	9
3.1 General bearer service user data characteristics.....	11
3.1.1 3,1 kHz Audio	11
3.1.2 V.110 UDI.....	11
3.1.3 X.31 Flag Stuffing UDI.....	12
3.1.4 V.120.....	12
3.1.5 Bit Transparent Mode	12
Annex A (informative): Change history	13
History	14

Intellectual Property Rights

IPRs essential or potentially essential to the present document may have been declared to ETSI. The information pertaining to these essential IPRs, if any, is publicly available for **ETSI members and non-members**, and can be found in SR 000 314: "*Intellectual Property Rights (IPRs); Essential, or potentially Essential, IPRs notified to ETSI in respect of ETSI standards*", which is available **free of charge** from the ETSI Secretariat. Latest updates are available on the ETSI Web server (<http://www.etsi.org/ipr>).

Pursuant to the ETSI IPR Policy, no investigation, including IPR searches, has been carried out by ETSI. No guarantee can be given as to the existence of other IPRs not referenced in SR 000 314 (or the updates on the ETSI Web server) which are, or may be, or may become, essential to the present document.

Foreword

This European Standard (Telecommunications series) has been produced by the Special Mobile Group (SMG), and is now submitted for the ETSI standards One-step Approval Procedure.

The present document defines a set of Bearer Services to be provided within the digital cellular telecommunications system.

The contents of the present document is subject to continuing work within SMG and may change following formal SMG approval. Should SMG modify the contents of the present document it will be re-released with an identifying change of release date and an increase in version number as follows:

Version 7.x.y

where:

- 7 indicates Release 1998 of GSM Phase 2+
- x the second digit is incremented for all changes of substance, i.e. technical enhancements, corrections, updates, etc.
- y the third digit is incremented when editorial only changes have been incorporated in the specification.

Proposed national transposition dates	
Date of latest announcement of this EN (doa):	3 months after ETSI publication
Date of latest publication of new National Standard or endorsement of this EN (dop/e):	6 months after doa
Date of withdrawal of any conflicting National Standard (dow):	6 months after doa

The specification from which the present document has been derived was originally based on CEPT documentation, hence the presentation of the present document may not be entirely in accordance with the ETSI drafting rules.

0 Scope

The present document defines a set of Bearer Services to be provided to GSM PLMN subscribers by a GSM PLMN itself and in connection with other networks. The present document should also be used as a reference for defining the corresponding required mobile network capabilities which are specified by means of the "GSM PLMN connection type" concept, defined in GSM 03.10 [4].

The recommended provision of the Bearer Services is under the control of the GSM MoU and is out of the scope of ETSI TC-SMG.

Bearer Services not included in the present document that require modifications to the GSM signalling specifications should not be introduced unilaterally by a mobile network operator.

0.1 References

The following documents contain provisions which, through reference in this text, constitute provisions of the present document.

- References are either specific (identified by date of publication, edition number, version number, etc.) or non-specific.
- For a specific reference, subsequent revisions do not apply.
- For a non-specific reference, the latest version applies.
- A non-specific reference to an ETS shall also be taken to refer to later versions published as an EN with the same number.
- For this Release 1998 document, references to GSM documents are for Release 1998 versions (version 7.x.y).

- [1] GSM 01.04 (ETR 350): "Digital cellular telecommunications system (Phase 2+); Abbreviations and acronyms".
- [2] GSM 02.01: "Digital cellular telecommunications system (Phase 2+); Principles of telecommunication services supported by a GSM Public Land Mobile Network (PLMN)".
- [3] GSM 02.04 (ETS 300 918): "Digital cellular telecommunications system (Phase 2+); General on supplementary services".
- [4] GSM 03.10: "Digital cellular telecommunications system (Phase 2+); GSM Public Land Mobile Network (PLMN) connection types".
- [5] GSM 04.02: "Digital cellular telecommunications system (Phase 2+); GSM Public Land Mobile Network (PLMN) access reference configuration".
- [6] GSM 07.01 (ETS 300 913): "Digital cellular telecommunications system (Phase 2+); General on Terminal Adaptation Functions (TAF) for Mobile Stations (MS)".
- [7] GSM 07.02 (ETS 300 914): "Digital cellular telecommunications system (Phase 2+); Terminal Adaptation Functions (TAF) for services using asynchronous bearer capabilities".
- [8] GSM 07.03 (ETS 300 915): "Digital cellular telecommunications system (Phase 2+); Terminal Adaptation Functions (TAF) for services using synchronous bearer capabilities".
- [9] GSM 07.05: "Digital cellular telecommunications system (Phase 2+); Use of Data Terminal Equipment - Data Circuit terminating Equipment (DTE - DCE) interface for Short Message Service (SMS) and Cell Broadcast Service (CBS)".
- [10] GSM 09.02 (ETS 300 974): "Digital cellular telecommunications system (Phase 2+); Mobile Application Part (MAP) specification".

- [11] GSM 09.03: "Digital cellular telecommunications system; Signalling requirements on interworking between the Integrated Services Digital Network (ISDN) or Public Switched Telephone Network (PSTN) and the Public Land Mobile Network (PLMN)".
- [12] GSM 09.04: "Digital cellular telecommunications system; Interworking between the Public Land Mobile Network (PLMN) and the Circuit Switched Public Data Network (CSPDN)".
- [13] GSM 09.05: "Digital cellular telecommunications system; Interworking between the Public Land Mobile Network (PLMN) and the Packet Switched Public Data Network (PSPDN) for Packet Assembly/Disassembly facility (PAD) access".
- [14] GSM 09.06 (ETS 300 975): "Digital cellular telecommunications system (Phase 2+); Interworking between a Public Land Mobile Network (PLMN) and a Packet Switched Public Data Network/Integrated Services Digital Network (PSPDN/ISDN) for the support of packet switched data transmission services".
- [15] GSM 09.07 (ETS 300 976): "Digital cellular telecommunications system (Phase 2+); General requirements on interworking between the Public Land Mobile Network (PLMN) and the Integrated Services Digital Network (ISDN) or Public Switched Telephone Network (PSTN)".
- [16] GSM 09.10: "Digital cellular telecommunications system (Phase 2+); Information element mapping between Mobile Station - Base Station System and BSS - Mobile-services Switching Centre (MS - BSS - MSC) Signalling procedures and the Mobile Application Part (MAP)".
- [17] GSM 09.11: "Digital cellular telecommunications system (Phase 2+); Signalling interworking for supplementary services".
- [18] CCITT Recommendation V.120: "Support by an ISDN of data terminal equipments with V-series type interface with provision for statistical multiplexing".
- [19] GSM 02.60: "Digital cellular telecommunications system (Phase 2+); General Packet Radio Service (GPRS); Service description; Stage 1"
- [20] GSM 07.60: "Digital cellular telecommunications system (Phase 2+); General Packet Radio Service (GPRS); Mobile Station (MS) supporting GPRS"
- [21] GSM 09.60: "Digital cellular telecommunications system (Phase 2+); General Packet Radio Service (GPRS); GPRS Tunnelling Protocol (GTP) across the Gn and Gp Interface"

0.2 Abbreviations

Abbreviations used in the present document are listed in GSM 01.04 [1].

1 Framework for defining Bearer Services

Bearer Services are described by attributes, which are intended to be independent. These attributes are described and defined in GSM 02.01 [2]. They are grouped into four categories:

- i) Information transfer attributes, which characterize the network capabilities for transferring information from a user access point in a GSM PLMN to a user access point in another network. (Refer to GSM 02.01 [2] and GSM 04.02 [5] for definitions of user access points, originating and terminating networks).
- ii) Access attributes, which describe the means for accessing network functions or facilities as seen at the access point in the PLMN (see GSM 02.01 [2]).
- iii) Interworking attributes, which describe properties of the terminating network and its access point. The terminating network may include another GSM PLMN or the originating PLMN (see GSM 02.01 [2]).
- iv) General attributes, which deal with the service in general.

Figure 1 shows the relation between the groups of attributes and their fields of applicability.

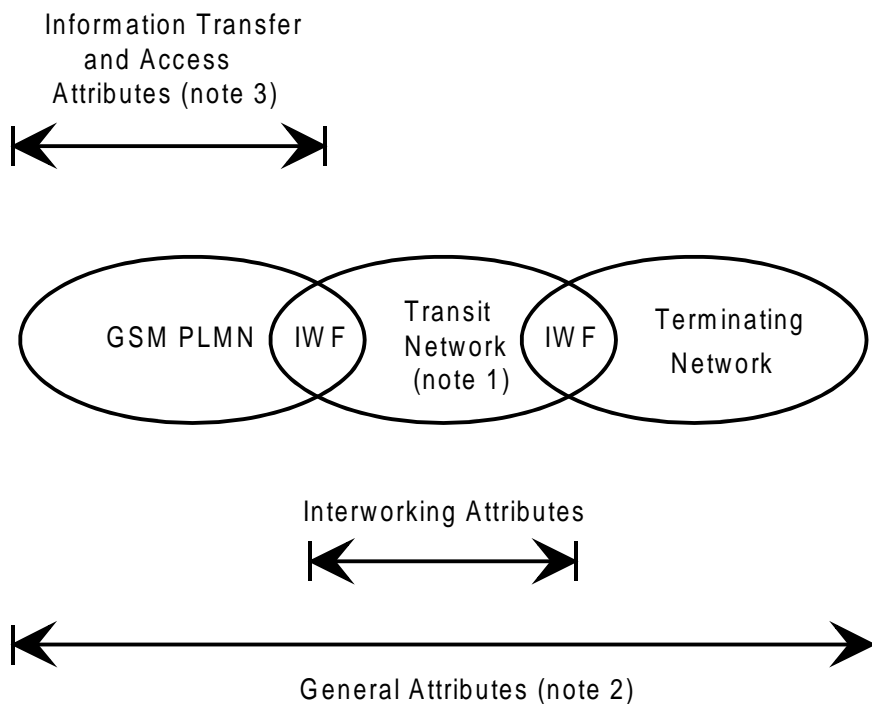

- NOTE 1: A transit network may not exist for a Bearer Service.
 NOTE 2: Communication may be established from either end.
 NOTE 3: The information transfer and access attributes of a Bearer Service relate to a direct peer-to-peer communication of:
- TE to TE;
 - TE to a network gateway (supporting, for example, PSTN interworking); or
 - network gateway to a TE.

Figure 1: Relation between the groups of attributes and fields of applicability

The following table lists the individual attributes in each of the four groups. The GSM Bearer Service definitions in the present document are based on the "Minimal Set" of attributes.

Table 1: List of Bearer Service attributes

	Minimal Set
Information Transfer Attributes	
Information Transfer Mode	X
Information Transfer Rate	X
Information Transfer Capability	X
Establishment of Communication	X
Symmetry	X
Communication Configuration	X
Data Compression	X
Access Attributes	
Access Channel and Rate	
Signalling Access Protocols	
Information Access Protocols	
Information Access Structure	X
Information Access Rate	X
Interworking Attributes	
General Attributes	
Supplementary Services Provided	
Quality of Service	X
Operational and Commercial	

Attributes that are not part of the minimal set provide further technical detail and are required to fully define the use of each Bearer Service.

General Packet Radio Service (GPRS) is specified in GSM 02.60 [19].

See the GSM 07-series specifications [6], [7], [8], [9], [20] for information about the Signalling Access Protocols, Information Access Protocols and related access attributes.

GSM supplementary services are defined in GSM 02.04 [3].

Intercommunication is required with services in the PSTN, ISDN, CSPDN, PDN, PSPDN and other PLMNs. The capabilities that describe the Interworking Attributes are described in GSM 03.10 [4] and the GSM 09-series specifications [10] to [15] and [21].

2 Bearer Service categories

All Bearer Service categories provide information transfer between R/S reference points and allow the use of sub-rate information streams which are rate-adapted.

The Bearer Services can be grouped into the following categories:

- Unrestricted Digital Information (UDI);

Provides the transfer of unrestricted digital information.

- 3,1 kHz (External to the PLMN);

Used to select a "3,1 kHz audio" interworking function at the MSC. This service category is used when interworking with the ISDN or PSTN "3,1 kHz audio" service and includes the capability to select a modem at the interworking function. "External to the PLMN" indicates that the "3,1 kHz audio" service is only used outside of the PLMN, in the ISDN/PSTN. The connection within the PLMN, user access point to the interworking function, is an unrestricted digital connection.

- PAD;

Provides an asynchronous connection to a PAD. This enables PLMN subscribers to access a packet network (PSPDN/ISDN). See GSM 09.05 [13] for service and interworking specifications.

- Packet;

Provides a synchronous connection that enables PLMN subscribers to access a packet network (PSPDN/ISDN). See GSM 09.06 [14] for service and interworking specifications.

- Alternate Speech/Data;

Provides the capability to swap between speech and data during a call.

If either the speech or data portion of the call requires a full rate channel, a full rate channel shall be used for the duration of the call.

- If the data portion of the call requires multiple full rate channels, the speech portion uses a single full rate channel.

The access interface at the mobile station for the data portion is assumed to be a standard data interface. Some means must be provided to select the speech/data capability.

- Speech followed by Data;

Provides a speech connection first and then at some time while the call is in progress, the user can switch to a data connection. The user cannot switch back to speech after the data portion.

If either the speech or data portion of the call requires a full rate channel, a full rate channel shall be used from the start of the call. The network may then change to a half rate channel for the data portion.

- If the data portion of the call requires multiple full rate channels, a single full rate channel shall be used from the start of the call.

- General Packet Radio Service (GPRS)

GPRS provides Internet (IP) and X.25 interworking with external networks. See GSM 02.60.

3 Bearer Services

This clause provides a list of the existing GSM Bearer Services and indicates the values for each attribute in the minimal set.

The following attributes have the same value for all GSM Bearer Services. Their values are as follows:

- Information Transfer Mode: "Circuit" (note 1);;
- Information Transfer Rate: Not applicable (note 2);
- Establishment of Communication: "Demand";
- Symmetry: "Bi-directional Symmetric" (note 3);
- Communication Configuration: "Point to point".

NOTE 1: GPRS (BS 70) requires "packet" information transfer mode.

NOTE 2: The Information Transfer Rate attribute is not applicable because it depends on the reference point assumed in the GSM PLMN, transit or terminating network.

NOTE 3: Asynchronous services using 1 200/75 bps. and GPRS (BS 70) require a value of "Bi-directional Asymmetric".

All GSM asynchronous NT Bearer Services may support data compression to enhance user data throughput.

GSM NT Bearer Services 2x and 3x may support V.120 interworking, enabling data terminals connected to an MS to interwork with V.120 [18] terminal adapters on the ISDN as shown in the figure 2 below.

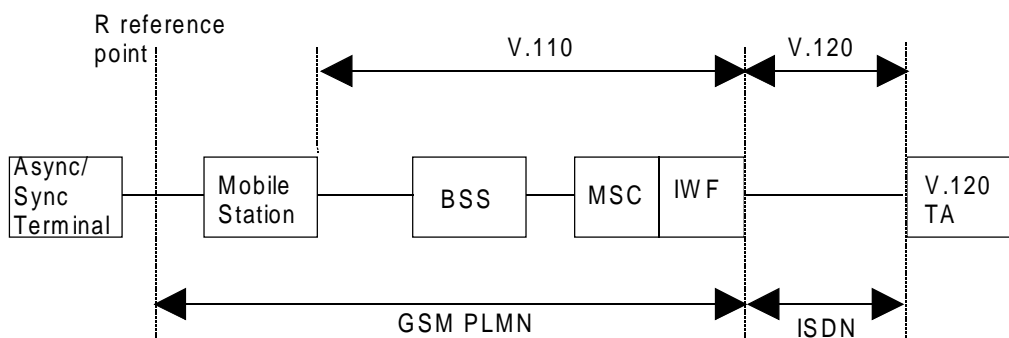

Figure 2: Model of GSM V.120 Interworking

Table 2 contains the list of the Bearer Services and the values for the remaining attributes in the minimal set.

Table 2

Bearer Service Number	Bearer Service Name	Access Structure	Access Rate	Information Transfer Capability	QOS Attribute	Notes
20	Asynchronous General Bearer Service	Asynch	note 7	note 7	note 7	See note 6
21	Asynchronous 300 bps	Asynch	300 bps	UDI or 3.1KHz	T or NT	
22	Asynchronous 1.2 kbps	Asynch	1.2 kbps	UDI or 3.1kHz	T or NT	
23	Asynchronous 1200/75 bps	Asynch	1 200/75 bps	UDI or 3.1kHz	T or NT	See note 4
24	Asynchronous 2.4 kbps	Asynch	2.4 kbps	UDI or 3.1kHz	T or NT	
25	Asynchronous 4.8 kbps	Asynch	4.8 kbps	UDI or 3.1kHz	T or NT	
26	Asynchronous 9.6 kbps	Asynch	9.6 kbps	UDI or 3.1kHz	T or NT	
30	Synchronous General Bearer Service	Synch	note 7	note 7	note 7	See notes 1 and 6
31	Synchronous 1.2 kbps	Synch	1.2 kbps	UDI or 3.1kHz	T	
32	Synchronous 2.4 kbps	Synch	2.4 kbps	UDI or 3.1kHz	T or NT	See note 1
33	Synchronous 4.8 kbps	Synch	4.8 kbps	UDI or 3.1kHz	T or NT	See note 1
34	Synchronous 9.6 kbps	Synch	9.6 kbps	UDI or 3.1kHz	T or NT	See note 1
40	General PAD Access Bearer Service	Asynch	note 7	note 7	note 7	See notes 2,4, 5 and 6
41	PAD Access 300 bps	Asynch	300 bps	UDI	T or NT	See note 2 See note 5
42	PAD Access 1.2 kbps	Asynch	1.2 kbps	UDI	T or NT	See note 2 See note 5
43	PAD Access 1 200/75 bps	Asynch	1200/75 bps	UDI	T or NT	See note 2 See note 4 See note 5
44	PAD Access 2.4 kbps	Asynch	2.4 kbps	UDI	T or NT	See note 2 See note 5
45	PAD Access 4.8 kbps	Asynch	4.8 kbps	UDI	T or NT	See note 2 See note 5
46	PAD Access 9.6 kbps	Asynch	9.6 kbps	UDI	T or NT	See note 2 See note 5
50	General Packet Access Bearer Service	Synch	note 7	note 7	note 7	See notes 5 and 6
51	Packet Access 2.4 kbps	Synch	2.4 kbps	UDI	NT	See note 5
52	Packet Access 4.8 kbps	Synch	4.8 kbps	UDI	NT	See note 5
53	Packet Access 9.6 kbps	Synch	9.6 kbps	UDI	NT	See note 5
61	Alternate Speech/ Data					See note 3
70	GPRS	Asynch	Variable	UDI	T or NT	
81	Speech Followed by Data					See note 3

NOTE 1: The non-transparent versions of Bearer Services 32, 33 and 34 are only specified for the Basic Packet service, defined in GSM 09.06 [14].

NOTE 2: Although the general information transfer capability is UDI, the information transfer capability on the network-specific interface between the IWF and the PAD may be UDI or 3,1 kHz and is the choice of the network operator.

NOTE 3: The data phase of Bearer Services 61 and 81 will be the same as Bearer Services 20 - 34 with 3,1 kHz Information Transfer Capability.

NOTE 4: Bearer Service 23 and 43 are applicable to Mobile Originated (MO) calls only. The 75 bps is used in the uplink and the 1200 bps is used in the downlink.

NOTE 5: This Bearer Service is applicable to Mobile Originated (MO) calls only.

NOTE 6: This General Bearer is independent of any nominal rate. It is elaborated in more detail in subclause 3.1

NOTE 7: Please refer to subclause 3.1.

3.1 General bearer service user data characteristics

The tables below describe the characteristics of the General Bearer Services. The indicated fixed network user rates are possible, but support of General Bearer Service does not imply support of all rates.

3.1.1 3,1 kHz Audio

Fixed Network User Rate	Access Structure	Information Transfer Capability	QoS attributes	Note
0.3 kbit/s	Asynch	3,1 kHz	NT or T	note 2
1.2 kbit/s	Asynch, Synch	3,1 kHz	NT or T	notes 1 and 2
1.2/0.075 kbit/s	Asynch	3,1 kHz	NT or T	note 2
2.4 kbit/s	Asynch, Synch	3,1 kHz	NT or T	note 2
4.8 kbit/s	Asynch, Synch	3,1 kHz	NT or T	note 2
9.6 kbit/s	Asynch, Synch	3,1 kHz	NT or T	note 2
14.4 kbit/s	Asynch, Synch	3,1 kHz	NT or T	
19.2 kbit/s	Asynch, Synch	3,1 kHz	NT or T	
28.8 kbit/s	Asynch, Synch	3,1 kHz	NT or T	

NOTE 1: Not applicable to synchronous NT service.

NOTE 2: These services are also supported by the GSM Phase 2 Specifications.

3.1.2 V.110 UDI

Fixed Network User Rate	Access Structure	User Information Layer 1 protocol	QoS Attribute	Notes
0.3 kbit/s	Asynch	V.110	NT or T	note 2
1.2 kbit/s	Asynch, Synch	V.110	NT or T	note 1 note 2
2.4 kbit/s	Asynch, Synch	V.110	NT or T	note 2
4.8 kbit/s	Asynch, Synch	V.110	NT or T	note 2
9.6 kbit/s	Asynch, Synch	V.110	NT or T	note 2
14.4 kbit/s	Asynch, Synch	V.110	NT or T	
19.2 kbit/s	Asynch, Synch	V.110	NT or T	
28.8 kbit/s	Asynch, Synch	V.110	NT or T	
38.4 kbit/s	Asynch, Synch	V.110	NT or T	
48 kbit/s	Synch	V.110	T	
56 kbit/s	Synch	V.110	T (in a 64 kbit/s environment)	

NOTE 1: Not applicable to synchronous NT service.

NOTE 2: These services are also supported by the GSM Phase 2 Specifications.

3.1.3 X.31 Flag Stuffing UDI

Fixed Network User Rate	Access Structure	User Information Layer 1 protocol	QoS Attribute	Notes
2.4 kbit/s	Synch	X.31 Flag Stuffing	NT	note 1
4.8 kbit/s	Synch	X.31 Flag Stuffing	NT	note 1
9.6 kbit/s	Synch	X.31 Flag Stuffing	NT	note 1
14.4 kbit/s	Synch	X.31 Flag Stuffing	NT	
19.2 kbit/s	Synch	X.31 Flag Stuffing	NT	
28.8 kbit/s	Synch	X.31 Flag Stuffing	NT	
38.4 kbit/s	Synch	X.31 Flag Stuffing	NT	
48 kbit/s	Synch	X.31 Flag Stuffing	NT	
56 kbit/s	Synch	X.31 Flag Stuffing	NT	

NOTE 1: These services are also supported by the GSM Phase 2 Specifications.

3.1.4 V.120

Fixed Network User Rate	Access Structure	User Information Layer 1 protocol	QoS Attribute	Notes
1.2 kbit/s	Asynch	V.120	NT	
2.4 kbit/s	Asynch, Synch	V.120	NT	
4.8 kbit/s	Asynch, Synch	V.120	NT	
9.6 kbit/s	Asynch, Synch	V.120	NT	
14.4 kbit/s	Asynch, Synch	V.120	NT	
19.2 kbit/s	Asynch, Synch	V.120	NT	
28.8 kbit/s	Asynch, Synch	V.120	NT	note 1
38.4 kbit/s	Asynch, Synch	V.120	NT	
48 kbit/s	Asynch, Synch	V.120	NT	
56 kbit/s	Asynch, Synch	V.120	NT	note 2

NOTE 1: Requires a new code point in V.120 specification to be defined.

NOTE 2: Not applicable in a 56 kbit/s environment.

3.1.5 Bit Transparent Mode

Fixed Network User Rate	Access Structure	User Information Layer 1 protocol	QoS Attribute	Notes
56 kbit/s	Synch	Bit transparent	T (RDI) (in a 56 kbit/s environment)	
64 kbit/s	Synch	Bit transparent	T (UDI) (in a 64 kbit/s environment)	

Annex A (informative): Change history

Change history					
SMG No.	TDoc. No.	CR. No.	Subclause affected	New version	Subject/Comments
SMG#22	305/97	A004	2.0	5.3.0	HSCSD use of multiple TS in alternate & followed by Services.
SMG#28	812/99	A006	0,1, 2, 3	7.0.0	Addition of Supplementary Code for GPRS. (R98) <i>Applied March 2, 1999 based on R97</i>

History

Document history			
Edition 1	November 1996	Unified Approval Procedure	UP 58: 1996-11-18 to 1997-03-14
Edition 1	April 1997	Publication as ETS 300 904	
Edition 2	July 1997	One-step Approval Procedure	OAP 9747: 1997-07-21 to 1997-11-28
Edition 2	December 1997	Publication as ETS 300 904	
V6.1.0	January 1999	One-step Approval Procedure	OAP 9934: 1999-04-23 to 1999-08-20
V7.0.1	July 1999	One-step Approval Procedure	OAP 9952: 1999-07-28 to 1999-11-26