

Draft **ETSI EN 300 827** V1.2.1 (1999-12)

---

*Candidate Harmonized European Standard (Telecommunications series)*

**Electromagnetic compatibility  
and Radio spectrum Matters (ERM);  
ElectroMagnetic Compatibility (EMC) standard  
for Terrestrial Trunked Radio (TETRA) and ancillary equipment**

---



---

**Reference**REN/ERM-EMC-215

---

---

**Keywords**EMC, radio, TETRA

---

**ETSI**

---

**Postal address**F-06921 Sophia Antipolis Cedex - FRANCE

---

---

**Office address**

650 Route des Lucioles - Sophia Antipolis  
Valbonne - FRANCE  
Tel.: +33 4 92 94 42 00 Fax: +33 4 93 65 47 16  
Siret N° 348 623 562 00017 - NAF 742 C  
Association à but non lucratif enregistrée à la  
Sous-Préfecture de Grasse (06) N° 7803/88

---

**Internet**

secretariat@etsi.fr  
Individual copies of this ETSI deliverable  
can be downloaded from  
<http://www.etsi.org>  
If you find errors in the present document, send your  
comment to: editor@etsi.fr

---

**Important notice**

---

This ETSI deliverable may be made available in more than one electronic version or in print. In any case of existing or perceived difference in contents between such versions, the reference version is the Portable Document Format (PDF). In case of dispute, the reference shall be the printing on ETSI printers of the PDF version kept on a specific network drive within ETSI Secretariat.

---

**Copyright Notification**

---

No part may be reproduced except as authorized by written permission.  
The copyright and the foregoing restriction extend to reproduction in all media.

© European Telecommunications Standards Institute 1999.  
All rights reserved.

# Contents

Intellectual Property Rights.....	5
Foreword.....	5
1 Scope.....	6
2 References.....	6
3 Definitions and abbreviations.....	7
3.1 Definitions.....	7
3.2 Abbreviations.....	8
4 General test conditions.....	9
4.1 Test conditions and configurations.....	9
4.1.1 Emission measurements.....	9
4.1.2 Immunity tests.....	9
4.1.2.1 Mode of operation.....	10
4.1.2.2 Test modulation.....	10
4.1.2.3 Arrangements for wanted signals at the input of the transmitter.....	10
4.1.2.4 Arrangements for wanted signals at the output of the transmitter.....	10
4.1.2.5 Arrangements for wanted signals at the input of the receiver.....	11
4.1.2.6 Arrangements for wanted signals at the output of the receiver.....	11
4.1.2.7 Receiver and receivers of transceivers exclusion band.....	11
4.1.2.8 Transmitter exclusion band.....	12
4.1.2.9 Narrow band responses on receivers and receivers of transceivers.....	12
5 Performance assessment.....	12
5.1 General.....	12
5.2 Equipment which supports circuit mode traffic transmission.....	12
5.3 Equipment which does not support circuit mode traffic transmission.....	13
5.4 Ancillary equipment.....	13
5.5 Equipment classification.....	13
5.6 Performance assessment of audio breakthrough.....	13
6 Performance criteria.....	15
6.1 General.....	15
6.2 Performance criteria for Continuous phenomena applied to Transmitters (CT).....	15
6.2.1 Audio test criteria.....	15
6.2.2 Non-audio test criteria.....	16
6.3 Performance criteria for Transient phenomena applied to Transmitters (TT).....	16
6.4 Performance criteria for Continuous phenomena applied to Receivers (CR).....	16
6.4.1 Audio test criteria.....	16
6.4.2 Non-audio test criteria.....	16
6.5 Performance criteria for Transient phenomena applied to Receivers (TR).....	17
7 Applicability overview tables.....	17
7.1 Emission.....	17
7.2 Immunity.....	18
8 Test methods and limits for emission tests.....	18
8.1 Enclosure of the ancillary equipment.....	18
8.1.1 Definition.....	18
8.1.2 Test method.....	18
8.1.3 Limits.....	18
8.2 DC power input/output port.....	19
8.2.1 Definition.....	19
8.2.2 Test method.....	19
8.2.3 Limits.....	19
8.3 AC mains power input/output port.....	20

8.3.1	Definition.....	20
8.3.2	Test method .....	20
8.3.3	Limits.....	20
8.4	Harmonic current emissions (AC mains input port) .....	20
8.5	Voltage fluctuations and flicker (AC mains input port).....	20
9	Test methods and levels for immunity tests .....	21
9.1	Radio frequency electromagnetic field (80 MHz - 1 000 MHz) with or without ancillary equipment connected.....	21
9.1.1	Definition.....	21
9.1.2	Test method .....	21
9.1.3	Performance criteria.....	21
9.2	Electrostatic discharge.....	22
9.2.1	Definition.....	22
9.2.2	Test method .....	22
9.2.3	Performance criteria.....	22
9.3	Fast transients common mode.....	22
9.3.1	Definition.....	22
9.3.2	Test method .....	23
9.3.3	Performance criteria.....	23
9.4	RF common mode (0,15 MHz - 80 MHz) .....	23
9.4.1	Definition.....	23
9.4.2	Test method .....	23
9.4.3	Performance criteria.....	24
9.5	Transients and surges, vehicular environment .....	24
9.5.1	Definition.....	24
9.5.2	Test method .....	24
9.5.2.1	Requirements for 12 V DC powered equipment .....	25
9.5.2.2	Requirements for 24 V DC powered equipment .....	25
9.5.3	Performance criteria.....	25
9.6	Voltage dips and interruptions.....	26
9.6.1	Definition.....	26
9.6.2	Test method .....	26
9.6.3	Performance criteria.....	26
9.7	Surges common and differential mode .....	27
9.7.1	Definition.....	27
9.7.2	Test method .....	27
9.7.3	Performance criteria.....	27
<b>Annex A (normative):</b>	<b>Clauses and/or subclauses of the present document relevant for compliance with the essential requirements of the EC Council Directives .....</b>	<b>28</b>
History .....		29

---

## Intellectual Property Rights

IPRs essential or potentially essential to the present document may have been declared to ETSI. The information pertaining to these essential IPRs, if any, is publicly available for **ETSI members and non-members**, and can be found in SR 000 314: "*Intellectual Property Rights (IPRs); Essential, or potentially Essential, IPRs notified to ETSI in respect of ETSI standards*", which is available from the ETSI Secretariat. Latest updates are available on the ETSI Web server (<http://www.etsi.org/ipr>).

Pursuant to the ETSI IPR Policy, no investigation, including IPR searches, has been carried out by ETSI. No guarantee can be given as to the existence of other IPRs not referenced in SR 000 314 (or the updates on the ETSI Web server) which are, or may be, or may become, essential to the present document.

---

## Foreword

This Candidate Harmonized European Standard (Telecommunications series) has been produced by ETSI Technical Committee Electromagnetic compatibility and Radio spectrum Matters (ERM), and is now submitted for the Public Enquiry phase of the ETSI standards Two-step Approval Procedure.

The present document is based upon the Generic Standards EN 50081-1 [1] and EN 50082-1 [2] and other standards where appropriate.

The present document is based on the guidance and considerations given in ETR 238 [21].

The present document has been produced by ETSI in response to a mandate from the European Commission issued under Council Directive 98/34/EC (as amended) laying down a procedure for the provision of information in the field of technical standards and regulations.

For equipment within the scope of TBR 35 [22], the present document is intended to become a Harmonized Standard, the reference of which will be published in the Official Journal of the European Communities referencing the Council Directive on the approximation of the laws of the Member States relating to electromagnetic compatibility ("the EMC Directive") (89/336/EEC as amended).

For equipment outside the scope of TBR 35 [22], the present document, together with ETS 300 394-1 [12], is intended to become a Harmonized Standard, the reference of which is intended to be published in the Official Journal of the European Communities referencing the EMC Directive.

Technical specifications relevant to the EMC Directive are given in annex A.

For radio communications equipment which can be connected to the AC main supply, the requirements of EN 61000-3-2 [19] and EN 61000-3-3 [20] apply where appropriate from 1-1-2001.

<b>Proposed national transposition dates</b>	
Date of latest announcement of this EN (doa):	3 months after ETSI publication
Date of latest publication of new National Standard or endorsement of this EN (dop/e):	6 months after doa
Date of withdrawal of any conflicting National Standard (dow):	36 months after doa

---

# 1 Scope

The present document covers the assessment of Terrestrial Trunked Radio (TETRA) radiocommunications and ancillary equipment in respect of ElectroMagnetic Compatibility (EMC). Technical specifications related to the antenna port and emissions from the enclosure port of radio equipment are found in the related product standards for the effective use of the radio spectrum. The present document specifies the applicable EMC tests, the method of measurements, the limits and the minimum performance criteria for TETRA equipment and the associated ancillary equipment.

The environmental classification used in the present document refers to the environment classification used in the Generic Standards EN 50081-1 [1], EN 50082-1 [2], except for the vehicular environment class which refers to the ISO 7637-1 [10] and 7637-2 [11].

The EMC requirements have been selected to ensure an adequate level of compatibility for apparatus at residential, commercial, light industrial and vehicular environments. The levels do not cover extreme cases which may occur in any location but have a low probability of occurrence.

The present document may not cover those cases where a potential source of interference which is producing individually repeated transient phenomena or a continuous phenomena is permanently present, e.g. a radar or broadcast site in the near vicinity. In such a case it may be necessary to use special protection applied to either the source of interference or the interfered part or both.

Compliance of radio equipment to the requirements of the present document does not signify compliance to any requirements related to the use of the equipment (i.e. licensing requirements).

Compliance to the present document does not signify compliance to any safety requirements. However, it is the responsibility of the assessor of the equipment that any observations regarding apparatus becoming dangerous or unsafe as a result of the application of the tests of the present document, should be recorded in the test report.

---

# 2 References

The following documents contain provisions which, through reference in this text, constitute provisions of the present document.

- References are either specific (identified by date of publication, edition number, version number, etc.) or non-specific.
- For a specific reference, subsequent revisions do not apply.
- For a non-specific reference, the latest version applies.
- A non-specific reference to an ETS shall also be taken to refer to later versions published as an EN with the same number.

- [1] EN 50081-1 (1992): "Electromagnetic compatibility - Generic emission standard - Part 1: Residential, commercial and light industry".
- [2] EN 50082-1 (1993): "Electromagnetic compatibility - Generic immunity standard - Part 1: Residential, commercial and light industry".
- [3] EN 55022 (1994): "Limits and methods of measurement of radio disturbance characteristics of information technology equipment".
- [4] EN 61000-4-3 (modified): "Electromagnetic compatibility (EMC) - Part 4-3: Testing and measurement techniques - Radiated, radio-frequency, electromagnetic field immunity test".
- [5] EN 61000-4-2: "Electromagnetic compatibility (EMC) - Part 4-2: Testing and measurement techniques - Electrostatic discharge immunity test".
- [6] EN 61000-4-4: "Electromagnetic compatibility (EMC) - Part 4-4: Testing and measurement techniques - Electrical fast transient/burst immunity test".

- [7] EN 61000-4-6: "Electromagnetic compatibility (EMC) - Part 4-6: Testing and measurement techniques - Immunity to conducted disturbances, induced by radio-frequency fields".
- [8] EN 61000-4-11: "Electromagnetic compatibility (EMC) - Part 4-11: Testing and measurement techniques - Voltage dips, short interruptions and voltage variations immunity tests".
- [9] EN 61000-4-5: "Electromagnetic compatibility (EMC) - Part 4-5: Testing and measurement techniques - Surge immunity test".
- [10] ISO 7637-1 (1990): "Road vehicles - Electrical disturbance by conduction and coupling - Part 1: Passenger cars and light commercial vehicles with nominal 12 V supply voltage - Electrical transient conduction along supply lines only".
- [11] ISO 7637-2 (1990): "Road vehicles - Electrical disturbance by conduction and coupling - Part 2: Commercial vehicles with nominal 24 V supply voltage - Electrical transient conduction along supply lines only".
- [12] ETS 300 394-1: "Terrestrial Trunked Radio (TETRA); Conformance testing specification; Part 1: Radio".
- [13] ITU-T Recommendation O.153: " Basic parameters for the measurement of error performance at bit rate below the primary rate".
- [14] CISPR 16-1: "Specification for radio disturbance and immunity measuring apparatus and methods - Part 1: Radio disturbance and immunity measuring apparatus".
- [15] ETS 300 395-2 (1995): "Terrestrial Trunked Radio (TETRA); Speech codec for full-rate traffic channel; Part 2: TETRA codec".
- [16] ETS 300 392-2 "Terrestrial Trunked Radio (TETRA); Voice plus Data (V+D); Part 2: Air Interface (AI)".
- [17] ETS 300 396-2 "Terrestrial Trunked Radio (TETRA); Technical requirements for Direct Mode Operation (DMO); Part 2: Radio aspects".
- [18] ETS 300 393-2 "Terrestrial Trunked Radio (TETRA); Packet Data Optimized (PDO); Part 2: Air Interface (AI)".
- [19] EN 61000-3-2 (1995): "Electromagnetic compatibility (EMC) -- Part 3-2: Limits - Limits for harmonic current emissions (equipment input current up to and including 16A per phase)".
- [20] EN 61000-3-3 (1995): "Electromagnetic compatibility (EMC) -- Part 3: Limits -- Section 3: Limitation of voltage fluctuations and flicker in low-voltage supply systems for equipment with rated current up to 16 A".
- [21] ETR 238: ""ETSI/CENELEC standardization programme for the development of Harmonized Standards related to ElectroMagnetic Compatibility (EMC) in the field of telecommunications".
- [22] TBR 035: "Terrestrial Trunked Radio (TETRA); Emergency access".

---

## 3 Definitions and abbreviations

### 3.1 Definitions

For the purposes of the present document, the following terms and definitions apply.

**ancillary equipment:** equipment (apparatus), used in connection with a receiver, transmitter or transceiver is considered as an ancillary equipment (apparatus) if:

- the equipment is intended for use in conjunction with a receiver, transmitter or transceiver to provide additional operational and/or control features to the radio equipment (e.g. to extend control to another position or location); and
- the equipment cannot be used on a stand alone basis to provide user functions independently of a receiver, transmitter or transceiver; and
- the receiver, transmitter or transceiver to which it is connected, is capable of providing some intended operation such as transmitting and/or receiving without the ancillary equipment. (i.e. It is not a sub unit of the main equipment essential to the main equipment basic functions); and
- infrastructure and control equipment intended to provide the required data and communication link establishment shall be considered as ancillary equipment for the purposes of the present document

**enclosure port:** physical boundary of the apparatus onto which an electromagnetic field may radiate or impinge

**equipment which is capable of speech operation:** equipment that contains or can be directly connected to a microphone and/or loudspeaker or earpiece, or which includes analogue audio signal interfaces

**integral antenna:** antenna designed to be connected directly to the equipment with or without the use of an external connector and considered to be part of the equipment. An integral antenna may be fitted internally or externally to the equipment

**mobile station:** vehicular and portable stations are both treated as mobile stations (MS) (see ETS 300 394-1 [12]). In the present a portable station is equipment intended to be supplied by it's own battery and a vehicle mounted equipment is supplied by an external supply

**non-speech equipment:** equipment that does not have an audio input or output capability either built in or via audio signal interfaces. This category includes data only equipment, both base stations and terminals, and also (for example) V+D and PDO base stations and DMO repeaters which do not include any direct analogue audio capability

**port:** particular interface of the specified equipment (apparatus) with the external electromagnetic environment

**radio communications equipment:** apparatus which includes one or more transmitters and/or receivers and/or parts thereof. This type of equipment (apparatus) is used in a fixed, mobile or a portable application

## 3.2 Abbreviations

For the purposes of the present document, the following abbreviations apply:

AC	Alternative Current
BER	Bit Error Ratio
CR	Continuous phenomena applied to Receivers
CT	Continuous phenomena applied to Transmitters
DC	Direct Current
DMO	Direct Mode Operation
EMC	ElectroMagnetic Compatibility
ERP	Ear Reference Point
EUT	Equipment Under Test
IF	Intermediate Frequency
LISN	Line Impedance Stabilizing Networks
MER	Message Error Ratio
MRP	Mouth Reference Point
PDO	Packet Data Optimized
RF	Radio Frequency
SPL	Sound Pressure Level
TETRA	TErrestrial Trunked Radio
TR	Transient phenomena applied to Receivers
TT	Transient phenomena applied to Transmitters
V+D	Voice plus Data



---

## 4 General test conditions

This clause defines the general test configuration and is relevant to clauses 8 and 9.

### 4.1 Test conditions and configurations

The equipment shall be tested under normal test conditions as specified in ETS 300 394-1 [12]:

- the tests shall be carried out at a point within the specified normal operating environmental range of temperature and humidity, with the equipment connected to the rated power supply voltage;
- the test configuration shall be as close to normal intended use as possible;
- where portable (handheld) equipment is provided with a detachable integral antenna, it shall be tested with the antenna fitted in a manner typical of normal intended use, unless specified otherwise;
- if the equipment is part of a system, or can be connected to ancillary equipment, then it shall be acceptable to test the equipment while connected to the minimum configuration of ancillary equipment necessary to exercise the ports;
- ports which in normal operation are connected shall be connected to an ancillary equipment or to a representative piece of cable correctly terminated to simulate the input/output characteristics of the ancillary equipment, Radio Frequency (RF) input/output ports shall be correctly terminated;
- if the equipment has a large number of ports, then a sufficient number shall be selected to simulate actual operation conditions and to ensure that all the different types of termination are tested;
- ports which are not connected to cables during normal intended operation, e.g. service connectors, programming connectors, temporary connectors etc. shall not be connected to any cables for the purpose of EMC testing. Where cables have to be connected to these ports, or interconnecting cables have to be extended in length in order to exercise the Equipment Under Test (EUT), precautions shall be taken to ensure that the evaluation of the EUT is not affected by the addition or extension of these cables;
- the test conditions, test configuration and mode of operation shall be recorded in the test report.

#### 4.1.1 Emission measurements

This subclause defines the test conditions and configurations for the emission measurements as follows:

- the measurement shall be made in the operation mode e.g. transmit, idle and receive producing the largest emission in the frequency band being investigated consistent with normal applications;
- an attempt shall be made to maximize the detected radiated emission for example by moving the cables of the equipment.

#### 4.1.2 Immunity tests

This subclause defines the test conditions and configurations for the immunity tests as follows:

- the measurement shall be made in the mode of operation as required in subclause 4.1.2.1;
- for the immunity tests of ancillary equipment without a separate pass/fail criteria, the receiver, transmitter or transceiver coupled to the ancillary equipment, shall be used to judge whether the ancillary equipment passes or fails.

#### 4.1.2.1 Mode of operation

For the immunity tests of transmitters, the transmitter shall be operated at its maximum rated output power, modulated with normal test modulation (subclauses 4.1.2.2 and 4.1.2.3). A communication link shall be established (subclause 4.1.2.4) at the start of the test and maintained during the test. The mode of operation can either be test mode or normal operation.

For the immunity tests of receivers, the wanted input signal, coupled to the receiver, shall be modulated with normal test modulation (subclauses 4.1.2.2 and 4.1.2.5). A communication link shall be established (subclause 4.1.2.6) at the start of the test and maintained during the test.

For the immunity tests of duplex transceivers, the EUT may be configured in the repeater mode, consistent with the conditions given above.

For immunity tests of transceivers which can be operated in Direct Mode Operation (DMO) a communication link may be established between two transceivers, consistent with the above. For V+D or PDO equipment the communication link may be established between a mobile/portable station and a base station.

#### 4.1.2.2 Test modulation

The receiver wanted input signal shall be set to a frequency near to the middle of the operating band of the receiver modulated with one of the test signals listed below, the transmitter shall be set to a frequency near to the middle of the operating band of the transmitter modulated with one of the test signals listed below:

- for equipment capable of speech operation, a speech traffic channel (TETRA TCH/S) in accordance with ETS 300 395-2 [15] representing a 1020 Hz tone at a level of 17 dB below peak level;
- for non-speech V+D or DMO equipment, a TCH/7.2 test signal in accordance with ETS 300 392-2 [16] or ETS 300 396-2 [17] or ETS 300 394-1 [12];
- for non-speech V+D or DMO equipment, a SCH/F test signal in accordance with ETS 300 392-2 [16] or ETS 300 396-2 [17] or ETS 300 394-1 [12];
- for non-speech PDO equipment, a NBCH test signal in accordance with ETS 300 393-2 [18] or ETS 300 394-1 [12];
- for equipment capable of speech operation speech traffic channel (TETRA TCH/S) in accordance with ETS 300 395-2 [15] representing silence;
- for speech and/or data equipment connected to ancillary equipment intended for data operation, or connected to ancillary equipment which can be directly connected to a data application, the method of BER or MER measurement shall be agreed between the test house and the manufacturer.

The manufacturer may have to supply the test modulation/demodulation equipment.

The test signal generator (modulation) shall produce a continuous stream of data or messages where the data or message content is a pseudo random sequence with a length of 511 bits in accordance with ITU-T recommendation O.153 [13].

The test signal receiver (demodulator) shall produce a readout of BER/MER of a continuous data/message stream.

#### 4.1.2.3 Arrangements for wanted signals at the input of the transmitter

The transmitter should be modulated with normal test modulation, by an internal or external signal source capable of delivering the normal test modulation.

#### 4.1.2.4 Arrangements for wanted signals at the output of the transmitter

For equipment without an antenna connector, the wanted signal, to establish a communication link, shall be delivered from the equipment to an antenna located within the test environment. The measuring equipment of the wanted signal shall be located outside of the test environment. Adequate measures shall be taken to avoid the effect of the unwanted signal on the measuring equipment.

For equipment with an antenna connector, the wanted signal, to establish a communication link shall be delivered from the antenna connector by a coaxial cable. The measuring equipment of the wanted signal shall be located outside of the test environment. Adequate measures shall be taken to avoid the effect of the unwanted signal on the measuring equipment.

For equipment under test which can support Direct Mode Operation (DMO) a TETRA transceiver may form part of the measuring system. For V+D and PDO equipment a base station or a mobile/portable may form part of the measuring system.

#### 4.1.2.5 Arrangements for wanted signals at the input of the receiver

For equipment without an antenna connector, the wanted input signal, to establish a communication link, shall be presented to the equipment from an antenna located within the test environment. It shall be approximately 40 dB above the minimum level necessary to achieve the performance criteria of the receiver as defined in subclause 6.4, measured while the power amplifiers generating the EMC disturbance are switched on but without excitation. This level of the wanted input signal is expected to represent normal operation signal level and is sufficient to avoid the broad band noise from the power amplifiers, generating the EMC disturbance, from influencing the measurement. The source of the wanted input signal shall be located outside of the test environment.

For equipment with an antenna connector, the wanted input signal, to establish a communication link shall be presented to the antenna connector by a coaxial cable. The source of the wanted input signal shall be located outside of the test environment and shall be approximately 40 dB above the minimum level necessary to achieve the performance criteria, measured while the power amplifiers generating the EMC disturbance are switched on but without excitation.

For equipment under test which can support Direct Mode Operation (DMO) a TETRA transceiver may form part of the measuring system. For V+D and PDO equipment a base station or a mobile/portable may form part of the measuring system.

#### 4.1.2.6 Arrangements for wanted signals at the output of the receiver

For speech equipment the audio frequency output of the equipment should be coupled via an electrically non-conductive acoustic tube to an audio distortion meter or other measuring equipment outside of the test environment. The frequency response of the acoustic tube should be compensated so as to not accentuate the interferer over the wanted signal. Where it is not practical to use an electrically non-conductive acoustic tube, then other means of connecting the receiver output to an audio distortion meter or other measuring equipment shall be provided and recorded in the test report. Precautions shall be taken to ensure that any effect on the test is minimized.

For non-speech equipment the output of the receiver shall be coupled via an electrically non-conductive means to the test equipment outside the test environment. If the equipment has an output connector/port providing the receiver output then this port shall be used via a cable, consistent with the standard cable used in normal operation, connected to the test equipment outside the test environment. The test equipment may be supplied by the manufacturer. Precautions shall be taken to ensure that any effect on the test is minimized.

The TTCI interface defined in ETS 300 394-1 [12] annex C or the RF loopback method defined in ETS 300 394-1 [12] annex D may be applied, it shall be agreed with the test house and the manufacturer which method that shall be applied.

#### 4.1.2.7 Receiver and receivers of transceivers exclusion band

The exclusion band for receivers and receivers of transceivers is the frequency range determined by the switching range, as declared by the manufacturer, extended as follows:

- the lower frequency of the exclusion band is the lower frequency of the switching range, minus 5 % of the centre frequency of the switching range, or minus 10 MHz, whichever will result in the lowest frequency;
- the upper frequency of the exclusion band is the upper frequency of the switching range, plus 5 % of the centre frequency of the switching range, or plus 10 MHz, which ever will result in the highest frequency.

The switching range is the maximum frequency range over which the receiver can be operated without reprogramming or realignment.

#### 4.1.2.8 Transmitter exclusion band

The exclusion band for transmitters extends  $\pm 50$  kHz from the nominal operating frequency of the transmitter.

For transceivers and equipment operated in a duplex mode both the exclusions bands detailed in subclauses 4.1.2.7 and 4.1.2.8 apply simultaneously.

#### 4.1.2.9 Narrow band responses on receivers and receivers of transceivers

Responses on receivers or receivers of transceivers occurring during the test at discrete frequencies which are narrow band responses (spurious responses), are identified by the following method.

If during the test an unwanted signal creates a degradation of the audio or data output, it is necessary to establish whether the degradation is due to a narrow band response or to a wide band phenomena. Therefore, the unwanted signal frequency is increased by an amount equal to twice the bandwidth of the receiver Intermediate Frequency (IF) filter immediately preceding the demodulator, as declared by the manufacturer. For the purpose of the present document, in the absence of a narrow IF filter bandwidth declared by the manufacturer, the IF bandwidth shall be taken as 25 kHz.

The test is repeated with the frequency of the unwanted signal decreased by the same amount.

If the degradation disappears, then the response is considered as a narrow band response. If the degradation remains, this may be due to the fact that the offset has made the frequency of the unwanted signal correspond to the frequency of another narrow band response. Under these circumstances the procedure is repeated with the increase and decrease of the frequency of the unwanted signal adjusted two and one half times the bandwidth previously referred to.

If the degradation remains, the phenomena is considered wide band and therefore an EMC problem and the equipment fails the test.

Narrow band responses shall be disregarded.

---

## 5 Performance assessment

### 5.1 General

The manufacturer shall at the time of submission of the equipment for test, supply the following information to be recorded in the test report:

- the intended functions of the radio equipment which shall be in accordance with the documentation accompanying the equipment;
- the primary functions of the radio equipment to be tested during and after the EMC testing;
- the characteristics of the signal used for testing (random bit stream, message format, etc.) and the necessary test equipment delivered to enable the assessment of the EUT;
- the method to be used to verify that a communications link is established and maintained;
- the ancillary equipment to be combined with the radio equipment for testing (where applicable);
- an exhaustive list of ports, classified as either power or signal/control. Power ports shall further be classified as AC or DC power.

### 5.2 Equipment which supports circuit mode traffic transmission

The test arrangement and signals given in clause 4 apply to radio equipment, or a combination of radio equipment and ancillary equipment, which permits the establishment and maintenance of a circuit mode TCH/7.2 or TCH/S channel in accordance with ETS 300 392-2 [16] or ETS 300 394-1 [12] or ETS 300 396-2 [17] or ETS 300 395-2 [15].

### 5.3 Equipment which does not support circuit mode traffic transmission

If the equipment does not permit or allow for a communications link to be established and maintained during the EMC tests (as in subclause 5.2) or in the case of ancillary equipment tested in isolation, not connected to radio equipment, the manufacturer shall define the performance assessment. The manufacturer shall provide the method of observing the degradation of performance of the equipment.

The performance assessment carried out shall be simple, but at the same time give adequate proof that the primary functions of the equipment are operational.

### 5.4 Ancillary equipment

At the manufacturers discretion an ancillary equipment may be:

- declared compliant separately (in isolation) from a receiver, transmitter or transceiver to all the applicable immunity and emission clauses of the present document; or
- declared compliant to another appropriate harmonized EMC standard; or
- tested with it connected to a receiver, transmitter or transceiver in which case compliance shall be demonstrated to the appropriate clauses of the present document.

### 5.5 Equipment classification

Portable equipment or combinations of equipment declared as capable of being powered by the battery in the vehicle shall additionally be considered as a vehicular mobile equipment.

Portable or mobile equipment or combinations of equipment declared as capable of being powered by AC mains shall additionally be considered as a base station equipment.

### 5.6 Performance assessment of audio breakthrough

This test only applies to equipment, which contains audio capability. The audio paths are enabled.

A communication link shall be set up with a suitable TETRA transceiver, system simulator, or test set (hereafter called "the test system"), which to apply should be agreed between the test house and the manufacturer.

When the EUT is required to be in the transmit/receive mode, the following conditions shall be met:

- the EUT shall be set to operate at maximum transmit power;
- prior to the test sequence, the reference level of the speech output signal on both the downlink and uplink shall be recorded on the test instrumentation, as shown in figure 2. The reference level shall be equivalent to 0 dBPa at 1020 Hz at the Ear Reference Point (ERP), or +5,0 dBPa at the loudspeaker for the downlink and -5 dBPa at 1020 Hz at the Mouth Reference Point (MRP), or the microphone for the uplink. The nominal acoustic test levels may need to be adapted for different types of TETRA equipment and for different acoustic test arrangements.
- the level of the output signal from the EUT's downlink speech channel at the mobile or portable's ear piece shall be assessed by measuring the Sound Pressure Level (SPL) as shown in figure 1;
- the level of the recovered audio output signal of the test system from the EUT's uplink speech channel shall be measured. Pick up of extraneous background noise by the EUT's microphone shall be minimized.

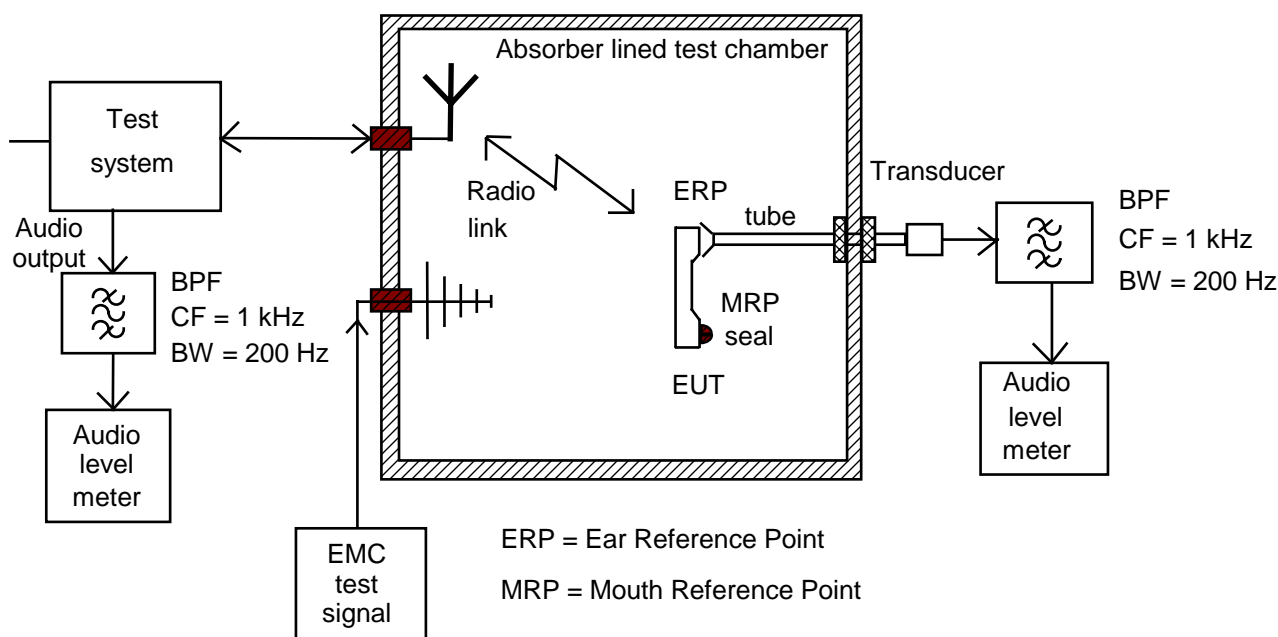

NOTE: In the case of a mobile equipment the ERP may be the loudspeaker, and the MRP the microphone.

Figure 1: Audio breakthrough measurement, test set-up

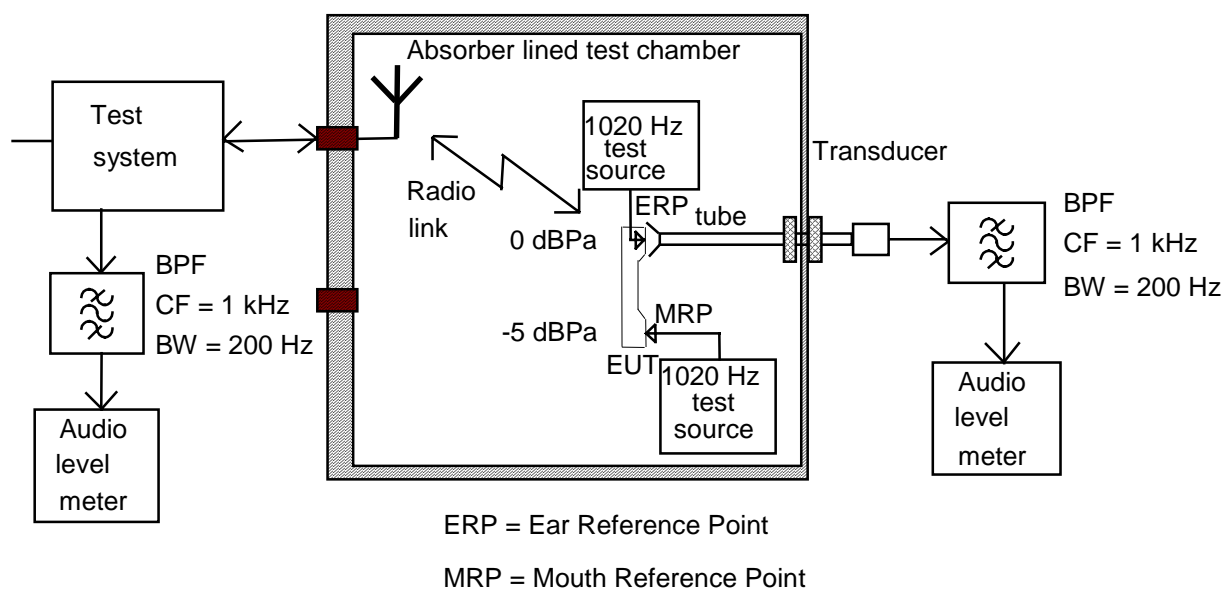

NOTE 1: The EUT is in position during calibration of the uplink, but not during calibration of the downlink.

NOTE 2: Where the EUT has a loudspeaker the reference level shall be equivalent to +5,0 dBPa at 1020 Hz.

Figure 2: Audio breakthrough measurement, calibration set-up

---

## 6 Performance criteria

### 6.1 General

The equipment shall meet the minimum performance criteria as specified in subclauses 6.2, 6.3, 6.4 and 6.5.

The establishment of the communication link at the start of the test, its maintenance and the assessment of the recovered signal are used as the performance criteria for the evaluation of the primary functions of the equipment during and after the test.

A portable equipment powered by the battery in the vehicle shall fulfil the applicable requirements set out by the present document for vehicular mobile equipment.

A portable or mobile equipment powered by AC mains shall fulfil the applicable requirements set out by the present document for base station equipment, although the tests performed are only those applicable to the input/output arrangements of the equipment, the performance criteria will remain as the origin class for the equipment.

If an equipment is of a specialized nature and the performance criteria specified in the table are not appropriate the manufacturer shall declare a substituted specification for an acceptable performance level or performance degradation as required by the present document. The performance specification shall be included in the test report and the product description and documentation.

The performance criteria specified by the manufacturer shall give the same degree of immunity protection as called for in the following subclauses.

### 6.2 Performance criteria for Continuous phenomena applied to Transmitters (CT)

Equipment that is capable of speech operation shall meet the audio test criteria in 6.2.1.

Non-speech equipment shall meet the performance criteria of 6.2.2.

At the conclusion of the test the EUT shall operate as intended with no loss of user control functions or stored data, and the communication link shall have been maintained during the test.

Where the EUT is a transmitter only, tests shall be repeated with the EUT in standby mode to ensure that unintentional transmission does not occur.

#### 6.2.1 Audio test criteria

Audio breakthrough test:

For details see subclause 5.6. The uplink and downlink speech output levels shall be at least 35 dB less than the previously recorded reference level, when measured through an audio band pass filter of 200 Hz width, centred on 1020 Hz (t.b.d.).

Audio link test:

During the audio breakthrough test the speech channel shall maintain its functionality and shall not be accidentally muted because of exposure to EMC phenomena. The test may be made either as a separate test or integrated in the audio breakthrough test by adding at each testpoint an extra measurement of the transfer function of an imposed audio signal. The precise implementation method is left to the test laboratory.

## 6.2.2 Non-audio test criteria

For non voice equipment the performance criteria can be either:

- the BER of the test signal shall not exceed  $10^{-2}$  (TCH7.2 for V+D or DMO) during the test sequence; or
- the Message Error Ratio (MER) (SCH/F for V+D, NBCH for PDO) shall not exceed 20 %, or 80 % of the transmitted messages shall be received correctly.

## 6.3 Performance criteria for Transient phenomena applied to Transmitters (TT)

At the conclusion of each exposure the EUT shall operate with no user noticeable loss of the communication link.

At the conclusion of the total test comprising the series of individual exposures the EUT shall operate as intended with no loss of user control functions or stored data, as declared by the manufacturer, and the communication link shall have been maintained.

Where the EUT is a transmitter only, tests shall be repeated with the EUT in standby mode to ensure that unintentional transmission does not occur.

## 6.4 Performance criteria for Continuous phenomena applied to Receivers (CR)

Equipment that is capable of speech operation shall meet the audio test criteria in 6.4.1.

Non-speech equipment shall meet the performance criteria of 6.4.2

At the conclusion of the test the EUT shall operate as intended with no loss of user control functions or stored data, and the communication link shall have been maintained during the test.

Where the EUT is a transceiver only, tests shall be repeated with the EUT in standby mode to ensure that unintentional transmission does not occur.

### 6.4.1 Audio test criteria

Audio breakthrough test:

For details see subclause 5.6. The uplink and downlink speech output levels shall be at least 35 dB less than the previously recorded reference level, when measured through an audio band pass filter of 200 Hz width, centred on 1020 Hz (t.b.d.).

Audio link test:

During the audio breakthrough test the speech channel shall maintain its functionality and shall not be accidentally muted because of exposure to EMC phenomena. The test may be made either as a separate test or integrated in the audio breakthrough test by adding at each testpoint an extra measurement of the transfer function of an imposed audio signal. The precise implementation method is left to the test laboratory.

### 6.4.2 Non-audio test criteria

For non voice equipment the performance criteria can be either:

- the BER of the test signal shall not exceed  $10^{-2}$  (TCH7.2 for V+D or DMO) during the test sequence; or
- the Message Error Ratio (MER) (SCH/F for V+D, NBCH for PDO) shall not exceed 20 %, or 80 % of the transmitted messages shall be received correctly.



## 6.5 Performance criteria for Transient phenomena applied to Receivers (TR)

At the conclusion of each exposure the EUT shall operate with no user noticeable loss of the communication link.

At the conclusion of the total test comprising the series of individual exposures the EUT shall operate as intended with no loss of user control functions or stored data, as declared by the manufacturer, and the communication link shall have been maintained.

Where the EUT is a transceiver, under no circumstances shall the transmitter operate unintentionally during the test.

---

## 7 Applicability overview tables

### 7.1 Emission

Table 1

Phenomenon	Application	Equipment test requirement			Reference subclause in the present document	Reference document
		Base station and ancillary equipment for fixed use	Mobile and ancillary equipment for vehicular use	Portable and ancillary equipment for portable use		
Radiated emission	Enclosure of ancillary equipment	applicable for stand alone testing	applicable for stand alone testing	applicable for stand alone testing	8.1	EN 55022 [3]
Conducted emission	DC power input/output port	applicable	applicable	not applicable	8.2	EN 55022 [3]
Conducted emission	AC mains input/output port	applicable	not applicable	not applicable	8.3	EN 55022 [3]
Harmonic current emissions	AC mains input port	applicable	not applicable	not applicable	8.4	EN 61000-3-2 [19]
Voltage fluctuations and flicker	AC mains input port	applicable	not applicable	not applicable	8.5	EN 61000-3-3 [20]

## 7.2 Immunity

Table 2

Phenomenon	Application	Equipment test requirement			Reference subclause in the present document	Reference document
		Base station and ancillary for fixed use	Mobile and ancillary for vehicular use	Portable and ancillary for portable use		
RF electromagnetic field (80 MHz - 1 000 MHz)	Enclosure, radio equipment with or without ancillary connected	applicable	applicable	applicable	9.1	EN 61000-4-3 [4]
Electrostatic discharge	Enclosure	applicable	applicable	applicable	9.2	EN 61000-4-2 [5]
Fast transient common mode	Signal and control ports, DC and AC power input ports	applicable	not applicable	not applicable	9.3	EN 61000-4-4 [6]
RF common mode 0,15 MHz - 80 MHz	Signal and control ports, DC and AC power input ports	applicable	applicable	not applicable	9.4	EN 61000-4-6 [7]
Transients and surges	DC power input ports	not applicable	applicable	not applicable	9.5	ISO 7637 [10], [11]
Voltage dips and interruptions	AC mains power input ports	applicable	not applicable	not applicable	9.6	EN 61000-4-11 [8]
Surges common and differential mode	AC mains power input ports	applicable	not applicable	not applicable	9.7	EN 61000-4-5 [9]

---

## 8 Test methods and limits for emission tests

### 8.1 Enclosure of the ancillary equipment

This test is applicable to the enclosure of the ancillary equipment, i.e. not connected to the radio equipment.

This test shall be performed on a representative configuration of the ancillary equipment.

#### 8.1.1 Definition

This test assesses the ability of ancillary equipment to limit unwanted emissions from its own enclosure.

#### 8.1.2 Test method

The test method shall be in accordance with EN 55022 [3].

#### 8.1.3 Limits

The value of the limits from EN 55022 [3] (10 m measuring distance) shall be used for ancillary equipment which is tested whilst not connected to radio equipment.

**Table 3: Limits for unwanted emissions for ancillary equipment tested whilst not connected to radio equipment**

Frequency range	Limit (quasi-peak)
30 MHz - 230 MHz	30 dB $\mu$ V/m
> 230 MHz - 1 000 MHz	37 dB $\mu$ V/m

## 8.2 DC power input/output port

This test is applicable to equipment which may have DC cables longer than 3 m and to equipment that is connected to DC/DC converters that may have cables less than 3 m.

Equipment that is powered from an AC/DC converter, where the DC cable length is less than 3 m this test shall be performed on the AC port of the adapter.

This test is also applicable if the total length from the equipment to the DC power source is longer than 3 m.

This test shall be performed on a representative configuration of the radio equipment or a representative configuration of the combination of radio and ancillary equipment.

### 8.2.1 Definition

This test assesses the ability of transmitters, receivers, transceivers and ancillary equipment to limit internal noise from the DC power input ports.

### 8.2.2 Test method

For equipment with a current consumption below 16 A the test method shall be in accordance with EN 55022 [3] and the Line Impedance Stabilizing Networks (LISN) shall be connected to a DC power source.

For equipment with a current consumption above 16 A the DC power points shall be connected to 5  $\mu$ H.

Line Impedance Stabilizing Networks (LISN), with 50  $\Omega$  impedance measurement ports. The LISNs shall be in accordance with the requirements of Section 2 of CISPR 16-1 [14].

A measuring receiver shall be connected to each LISN measurement port in turn and the conducted emission recorded. The LISN measurement ports not being used for measurement shall be terminated with a 50  $\Omega$  load.

The equipment shall be installed with a ground plane as defined in EN 55022 [3]. The reference earth point of the LISNs shall be connected to the reference ground plane with a conductor as short as possible.

The measurement receiver shall be in accordance with the requirements of CISPR 16-1 [14].

### 8.2.3 Limits

The equipment shall meet the limits below (including the average limit and the quasi-peak limit) when using, respectively, an average detector receiver and a quasi-peak detector receiver and measured in accordance with the method described in subclause 8.2.2. If the average limit is met when using a quasi-peak detector, the equipment shall be deemed to meet both limits and measurement with the average detector receiver is unnecessary.

The limits in table 4 shall apply.

**Table 4: Limits**

Frequency range	Quasi-peak	Average
> 0,15 MHz - 0,5 MHz	66 dB $\mu$ V - 56 dB $\mu$ V	56 dB $\mu$ V - 46 dB $\mu$ V
> 0,5 MHz - 5 MHz	56 dB $\mu$ V	46 dB $\mu$ V
> 5 MHz - 30 MHz	60 dB $\mu$ V	50 dB $\mu$ V
NOTE: The limit decreases linearly with the logarithm of the frequency in the range 0,15 MHz to 0,50 MHz.		

## 8.3 AC mains power input/output port

This test is applicable to equipment powered by the AC mains.

This test shall be performed on a representative configuration of the radio equipment or a representative configuration of the combination of radio and ancillary equipment.

### 8.3.1 Definition

This test assesses the ability of transmitters, receivers, transceivers and ancillary equipment to limit internal noise from the AC mains power input ports.

### 8.3.2 Test method

The test method shall be in accordance with EN 55022 [3].

### 8.3.3 Limits

The limits in table 5 shall apply, which are in accordance with EN 55022 [3].

**Table 5: Limits for unwanted emissions**

Frequency range	Quasi-peak	Average
> 0,15 MHz - 0,5 MHz	66 dB $\mu$ V - 56 dB $\mu$ V	56 dB $\mu$ V - 46 dB $\mu$ V
> 0,5 MHz - 5 MHz	56 dB $\mu$ V	46 dB $\mu$ V
> 5 MHz - 30 MHz	60 dB $\mu$ V	50 dB $\mu$ V
NOTE: The limit decreases linearly with the logarithm of the frequency in the range 0,15 MHz to 0,50 MHz.		

## 8.4 Harmonic current emissions (AC mains input port)

The appropriate requirements of EN 61000-3-2 [19] for harmonic current emission apply for equipment covered by the scope of the present document.

## 8.5 Voltage fluctuations and flicker (AC mains input port)

The appropriate requirements of EN 61000-3-3 [20] for voltage fluctuations and flicker apply for equipment covered by the scope of the present document.

---

## 9 Test methods and levels for immunity tests

### 9.1 Radio frequency electromagnetic field (80 MHz - 1 000 MHz) with or without ancillary equipment connected

This test is applicable for base station, mobile, portable and ancillary equipment.

This test shall be performed on a representative configuration of the radio equipment or a representative configuration of the combination of radio and ancillary equipment or a representative configuration of the ancillary equipment tested whilst not connected to radio equipment.

#### 9.1.1 Definition

This test assesses the ability of transmitters, receivers, transceivers and ancillary equipment to operate as intended in the presence of a radio frequency electromagnetic field disturbance at the enclosure.

#### 9.1.2 Test method

The test method shall be in accordance with EN 61000-4-3 [4] except that the following requirements and evaluation of test results shall apply:

- the test level shall be 3 V/m unmodulated. The test shall then be amplitude modulated to a depth of 80 % by a sinusoidal audio signal of 400 Hz;
- for receivers and transmitters only, the stepped frequency increments shall be 1 % of the momentary frequency;
- for transmitters in transceivers with a non-continuous duty cycle the stepped frequency increments may be 10 % of the momentary frequency;
- the test shall be performed over the frequency range 80 MHz - 1 000 MHz with the exception of an exclusion band for transmitters and for receivers and duplex transceivers;
- the test shall be carried out on one surface. The surface selected to face the source of the interference signal shall be the one anticipated by the test house to be the most susceptible. The selected surface shall be recorded in the test report;
- responses on receivers and duplex transceivers occurring at discrete frequencies which are narrow band responses, are disregarded from the test;
- for duplex transceivers and equipment operated in a repeater mode both the exclusions bands detailed in subclauses 4.1.2.7 and 4.1.2.8 apply simultaneously;
- the test frequencies used shall be recorded in the test report.

#### 9.1.3 Performance criteria

For transmitters and duplex equipment tested in a repeater mode the performance criteria CT (subclause 6.2) shall apply.

For receivers and duplex transceivers not tested in a repeater mode the performance criteria CR (subclause 6.4) shall apply.

For ancillary the pass/fail criteria supplied by the manufacturer shall apply, unless the ancillary is tested in connection with receivers, transmitters or transceivers in which case the corresponding performance criteria above shall apply.

## 9.2 Electrostatic discharge

This test is applicable for base station, mobile, portable and ancillary equipment.

This test shall be performed on a representative configuration of the radio equipment or a representative configuration of the combination of radio and ancillary equipment.

### 9.2.1 Definition

This test assesses the ability of transmitters, receivers, transceivers and ancillary equipment to operate as intended in the event of an electrostatic discharge.

### 9.2.2 Test method

The test method shall be in accordance with ENV 61000-4-2 [5].

For transmitters, receivers, transceivers and ancillary equipment the following requirements and evaluation of test results shall apply:

- for contact discharge, the equipment shall be tested at  $\pm 4$  kV; for air discharge, the equipment shall be tested at  $\pm 8$  kV;
- electrostatic discharges shall be applied to all user exposable surfaces of the equipment except where the user documentation specifically indicates a requirement for appropriate protective measures.

### 9.2.3 Performance criteria

For transmitters and duplex equipment tested in a repeater mode the performance criteria TT (subclause 6.3) shall apply.

For receivers and duplex transceivers not tested in a repeater mode the performance criteria TR (subclause 6.5) shall apply.

For ancillary equipment the pass/fail criteria supplied by the manufacturer shall apply, unless the ancillary equipment is tested in connection with receivers, transmitters or transceivers in which case the corresponding performance criteria above shall apply.

## 9.3 Fast transients common mode

This test is applicable for base station equipment and ancillary equipment.

This test shall be performed on AC mains power input ports.

This test shall be performed on signal ports, control ports and DC power input ports if the cables may be longer than 3 m. For these ports, where this test is not carried out because the manufacturer declares that it is not intended to be used with cables longer than 3 m, a list of these ports which were not tested for this reason shall be included in the test report.

This test is also applicable if the total length from the equipment to the DC power source is longer than 3 m.

Equipment with a DC power input port declared for use with an AC/DC power adapter shall be tested on the AC power input side of a typical AC/DC power adapter as declared by the manufacturer (see subclause 5.1).

This test shall be performed on a representative configuration of the radio equipment or a representative configuration of the combination of radio and ancillary equipment.

### 9.3.1 Definition

This test assesses the ability of transmitters, receivers, transceivers and ancillary equipment to operate as intended in the event of fast transients on one of the input/output ports.

### 9.3.2 Test method

For transmitters, receivers, transceivers and ancillary equipment, which may have longer cables than 3 m, or are connected to the AC mains, the test method shall be in accordance with EN 61000-4-4 [6] except that the following requirements and evaluation of test results shall apply:

- the test level for signal and control ports shall be 0,5 kV open circuit voltage as given in EN 61000-4-4 [6];
- the test level for DC power input ports shall be 0,5 kV open circuit voltage as given in EN 61000-4-4 [6];
- the test level for AC mains power input ports shall be 1 kV open circuit voltage as given EN 61000-4-4 [6].

For AC and DC power input ports the transients shall be applied (in parallel) to all the wires in the cable with reference to the cabinet reference ground, (true common mode), the source impedance shall be 50  $\Omega$ .

### 9.3.3 Performance criteria

For transmitters and duplex equipment tested in a repeater mode the performance criteria TT (subclause 6.3) shall apply.

For receivers and duplex transceivers not tested in a repeater mode the performance criteria TR (subclause 6.5) shall apply.

For ancillary equipment the pass/fail criteria supplied by the manufacturer shall apply, unless the ancillary equipment is tested in connection with receivers, transmitters or transceivers in which case the corresponding performance criteria shall apply.

## 9.4 RF common mode (0,15 MHz - 80 MHz)

This test is applicable for base station, mobile and ancillary equipment.

This test shall be performed on signal, control, and DC power input ports of mobile and ancillary equipment, which may have cables longer than 2 m.

This test shall be performed on signal, control, DC power and AC mains power input ports of base station and fixed ancillary equipment, which may have cables longer than 1 m.

Where this test is not carried out on any port because the manufacturer declares that it is not intended to be used with cables longer than stated above, a list of ports which were not tested for this reason shall be included in the test report.

This test shall be performed on a representative configuration of the radio equipment or a representative configuration of the combination of radio and ancillary equipment.

### 9.4.1 Definition

This test assesses the ability of transmitters, receivers, transceivers and ancillary equipment to operate as intended in the presence of a radio frequency electromagnetic disturbance.

### 9.4.2 Test method

This test should be performed using the intrusive or direct connection method, where appropriate, but this method should not be used on multiway unshielded busses carrying high speed data or clocks see EN 61000-4-6 [7].

The current clamp injection test method may be used in accordance with EN 61000-4-6 [7].

The following requirements shall apply:

- the test level shall be 3 V RMS unmodulated. The test shall then be amplitude modulated to a depth of 80 % by a sinusoidal audio signal of 400 Hz;
- the test level shall be severity level 2 as given in EN 61000-4-6 [7] corresponding to 3 V RMS;

- the test shall be performed over the frequency range 150 kHz - 80 MHz with the exception of an exclusion band for transmitters, (subclause 4.1.2.8), and for receivers and duplex transceivers, (subclause 4.1.2.7);
- for receivers and transmitters only the stepped frequency increments shall be 50 kHz in the frequency range 150 kHz - 5 MHz and 1 % frequency increment of the momentary frequency in the frequency range 5 MHz - 80 MHz;
- for transmitters in transceivers with a non-continuous duty cycle the stepped frequency increments may be 500 kHz in the frequency range 150 kHz - 5 MHz and 10 % frequency increment of the momentary frequency in the frequency range 5 MHz - 80 MHz;
- responses on receivers and duplex transceivers occurring at discrete frequencies which are narrow band responses, are disregarded from the test (subclause 4.1.2.9);
- the test frequencies used shall be recorded in the test report.

### 9.4.3 Performance criteria

For transmitters and duplex equipment tested in a repeater mode the performance criteria CT (subclause 6.2) shall apply.

For receivers and duplex transceivers not tested in a repeater mode the performance criteria CR (subclause 6.4) shall apply.

For ancillary the pass/fail criteria supplied by the manufacturer shall apply, unless the ancillary is tested in connection with receivers, transmitters or transceivers in which case the corresponding performance criteria above shall apply.

## 9.5 Transients and surges, vehicular environment

These tests are applicable for mobile and ancillary equipment intended for use in a vehicular environment.

These tests shall be performed on 12 V and 24 V DC power input ports of mobile and ancillary equipment, intended for vehicular use.

These tests shall be performed on a representative configuration of the radio equipment or a representative configuration of the combination of radio and ancillary equipment.

### 9.5.1 Definition

These tests assess the ability of transmitters, receivers, transceivers and ancillary equipment to operate as intended in the event of transients and surges present on the DC power input ports in a vehicular environment.

### 9.5.2 Test method

The test method shall be in accordance with ISO 7637-1 [10] applicable for 12 V DC operated equipment and ISO 7637-2 [11] applicable for 24 V DC operated equipment except that the following requirements and evaluation of test results shall apply.

Equipment designed to operate at both 12 V and 24 V DC without component change, module change or adjustment shall be tested according to subclause 9.5.2.2.

Equipment designed to operate at both 12 V and 24 V DC but with component change, module change or adjustment shall be tested according to subclauses 9.5.2.1 and 9.5.2.2.



### 9.5.2.1 Requirements for 12 V DC powered equipment

Where the manufacturer in his installation documentation requires that the equipment to have a direct connection to the 12 V main vehicle battery the following pulses apply:

- pulse 3a and 3b, level II, with the test time reduced to 5 minutes for each;
- pulse 4, level II, 5 pulses, with the characteristics as follows:

$$V_s = -5 \text{ V}, \quad V_a = -2,5 \text{ V}, \quad t_6 = 25 \text{ ms}, \quad t_8 = 5 \text{ s}, \quad t_f = 5 \text{ ms}.$$

Where the manufacturer does not require a direct connection to the 12 V main vehicle battery, the following pulses apply, in addition to the pulses 3a, 3b and 4:

- pulse 1, level II,  $t_1 = 2,5 \text{ s}$ , 10 pulses;
- pulse 2, level II,  $t_1 = 2,5 \text{ s}$ , 10 pulses;
- pulse 7, level II, 5 pulses.

Where the tests for pulses 1, 2 and 7 are not performed because the manufacturer declares that the equipment requires a direct connection to the vehicle battery, this fact shall be recorded in the test report.

### 9.5.2.2 Requirements for 24 V DC powered equipment

Where the manufacturer in his installation documentation requires that the equipment to have a direct connection to the 24 V main vehicle battery the following pulses apply:

- pulse 3a and 3b, level II, with the test time reduced to 5 minutes for each;
- pulse 4, level II, 5 pulses, the test shall be carried out in accordance with ISO 7637-1 [10] but with the following characteristics:

$$V_s = -10 \text{ V}, \quad V_a = -5,0 \text{ V}, \quad t_6 = 25 \text{ ms}, \quad t_8 = 5 \text{ s}, \quad t_f = 5 \text{ ms}.$$

Where the manufacturer does not require a direct connection to the 24 V main vehicle battery, the following pulses apply, in addition to the pulses 3a, 3b and 4:

- pulse 1a, level II,  $t_1 = 2,5 \text{ s}$ ,  $R_i = 25 \Omega$ , 10 pulses;
- pulse 1b, level II,  $t_1 = 2,5 \text{ s}$ ,  $R_i = 100 \Omega$ , 10 pulses;
- pulse 2, level II,  $t_1 = 2,5 \text{ s}$ , 10 pulses.

Where the tests for pulses 1a, 1b and 2 are not performed because the manufacturer declares that the equipment requires a direct connection to the vehicle battery, this fact shall be recorded in the test report.

## 9.5.3 Performance criteria

For transmitters and Duplex equipment tested in a repeater mode, pulses 3a and 3b, the performance criteria CT (subclause 6.2) shall apply. For pulses 1, 1a, 1b, 2, 4 and 7 the performance criteria TT (subclause 6.3) shall apply, with the exception that the link need not be maintained during exposure and may have to be re-established.

For receivers and duplex transceivers not tested in a repeater mode pulses 3a and 3b the performance criteria CR (subclause 6.4) shall apply. For pulses 1, 1a, 1b, 2, 4 and 7 the performance criteria TR (subclause 6.5) shall apply, with the exception that the link need not be maintained during exposure and may have to be re-established.

For ancillary equipment the pass/fail criteria supplied by the manufacturer shall apply, unless the ancillary equipment is tested in connection with receivers, transmitters or transceivers in which case the corresponding performance criteria above shall apply.

## 9.6 Voltage dips and interruptions

These tests are applicable for base station and fixed ancillary equipment.

These tests shall be performed on AC mains power input ports.

These test shall be performed on a representative configuration of the radio equipment or a representative configuration of the combination of radio and ancillary equipment.

### 9.6.1 Definition

These tests assesses the ability of transmitters, receivers, transceivers and ancillary equipment to operate as intended in the event of voltage dips and interruptions on the AC mains power input ports.

### 9.6.2 Test method

The test method shall be in accordance with EN 61000-4-11 [8] except that the following requirements and evaluation of test results shall apply.

The test levels shall be:

- a voltage dip corresponding to a reduction of the supply voltage of 30 % for 10 ms; and
- a voltage dip corresponding to a reduction of the supply voltage of 60 % for 100 ms; and
- a voltage interruption corresponding to a reduction of the supply voltage of > 95 % for 5 s.

### 9.6.3 Performance criteria

For a voltage dip corresponding to a reduction of the supply voltage of 30 % for 10 ms the following performance criteria apply:

- for transmitters and duplex equipment tested in a repeater mode the performance criteria CT (subclause 6.2);
- for stand alone receivers or receivers which are part of simplex or duplex transceivers not tested in a repeater mode the performance criteria CR (subclause 6.4);
- for ancillary equipment the pass/fail criteria supplied by the manufacturer shall apply, unless the ancillary equipment is tested in connection with receivers, transmitters or transceivers in which case the corresponding performance criteria above shall apply.

For a voltage dip corresponding to a reduction of the supply voltage of 60 % for 100 ms the following performance criteria apply:

- for transmitters the performance criteria TT (subclause 6.3);
- for stand alone receivers or receivers which are part of simplex or duplex transceivers the performance criteria TR (subclause 6.5);
- for ancillary equipment the pass/fail criteria supplied by the manufacturer shall apply, unless the ancillary equipment is tested in connection with receivers, transmitters or transceivers in which case the corresponding performance criteria above shall apply.

For a voltage interruption corresponding to a reduction of the supply voltage of > 95 % for 5 s the following performance criteria apply:

- in the case where the equipment is fitted with or connected to a battery back-up the performance criteria TT (subclause 6.3) or TR (subclause 6.5) apply as appropriate;
- in the case where the EUT is powered solely from the AC mains supply (without the use of a parallel battery back-up) the communications link need not be maintained and may have to be re-established and volatile user data may have been lost.

In the event of loss of the communications link or in the event of loss of user data, this fact shall be recorded in the test report, the product description and the user documentation.

## 9.7 Surges common and differential mode

These tests are applicable for base station and fixed ancillary equipment.

These tests shall be performed on AC mains power input ports.

These tests shall be performed on a representative configuration of the radio equipment or a representative configuration of the combination of radio and ancillary equipment.

### 9.7.1 Definition

These tests assess the ability of transmitters, receivers, transceivers and ancillary equipment to operate as intended in the event of surges on the AC mains power input ports.

### 9.7.2 Test method

The test method shall be in accordance with EN 61000-4-5 [9] except that the following requirements and evaluation of test results shall apply:

- the test level shall be 1 kV open circuit voltage for common mode and 0,5 kV open circuit voltage for differential mode;
- the surges shall be applied (in parallel) to all the wires in the cable with reference to the cabinet reference ground, (true common mode), the series resistance shall be 10  $\Omega$ .

### 9.7.3 Performance criteria

For transmitters and duplex equipment tested in a repeater mode the performance criteria TT (subclause 6.3) shall apply.

For receivers and duplex transceivers not tested in a repeater mode the performance criteria TR (subclause 6.5) shall apply.

For ancillary equipment the pass/fail criteria supplied by the manufacturer shall apply, unless the ancillary equipment is tested in connection with receivers, transmitters or transceivers in which case the corresponding performance criteria above shall apply.

**Annex A (normative):**  
**Clauses and/or subclauses of the present document**  
**relevant for compliance with the essential requirements of**  
**the EC Council Directives**

**Table A.1: Clauses and/or subclauses of the present document relevant for compliance with the essential requirements of the EC Council Directives**

Clause/subclause number and title		Corresponding article of Council Directive 89/336/EEC	Qualifying remarks
8	Test methods and limits for emission tests		
8.1	Enclosure of the ancillary equipment	4(a)	
8.2	DC power input/output port	4(a)	
8.3	AC mains power input/output port	4(a)	
8.4	Harmonic current emissions (AC mains input port)	4(a)	
8.5	Voltage fluctuations and flicker (AC mains input port)	4(a)	
9	Test methods and levels for immunity tests		
9.1	Radio frequency electromagnetic field (80 MHz - 1 000 MHz) with or without ancillary equipment connected	4(b)	
9.2	Electrostatic discharge	4(b)	
9.3	Fast transients common mode	4(b)	
9.4	RF common mode (0,15 MHz - 80 MHz)	4(b)	
9.5	Transients and surges, vehicular environment	4(b)	
9.6	Voltage dips and interruptions	4(b)	
9.7	Surges common and differential mode	4(b)	

---

## History

<b>Document history</b>			
V1.2.1	December 1999	Public Enquiry	PE 200016: 1999-12-22 to 2000-04-21