

**Private Integrated Services Network (PISN);
Inter-exchange signalling protocol;
Circuit mode basic services;
Network Layer (NL);
Part 2: Abstract Test Suite (ATS) specification**



Reference

REN/ECMA-00159-2

KeywordsATS, circuit mode, layer 3, PINX, PISN, QSIG,
testing**ETSI**

Postal address

F-06921 Sophia Antipolis Cedex - FRANCE

Office address650 Route des Lucioles - Sophia Antipolis
Valbonne - FRANCE
Tel.: +33 4 92 94 42 00 Fax: +33 4 93 65 47 16
Siret N° 348 623 562 00017 - NAF 742 C
Association à but non lucratif enregistrée à la
Sous-Préfecture de Grasse (06) N° 7803/88

Internet

secretariat@etsi.fr

Individual copies of this ETSI deliverable
can be downloaded from<http://www.etsi.org>If you find errors in the present document, send your
comment to: editor@etsi.fr

Important notice

This ETSI deliverable may be made available in more than one electronic version or in print. In any case of existing or perceived difference in contents between such versions, the reference version is the Portable Document Format (PDF). In case of dispute, the reference shall be the printing on ETSI printers of the PDF version kept on a specific network drive within ETSI Secretariat.

Copyright Notification

No part may be reproduced except as authorized by written permission.
The copyright and the foregoing restriction extend to reproduction in all media.

© European Telecommunications Standards Institute 2000.
All rights reserved.

Contents

Intellectual Property Rights	6
Foreword	6
1 Scope	7
2 References	7
3 Definitions and abbreviations	8
3.1 Definitions	8
3.2 Abbreviations	9
4 Abstract Test Method (ATM)	10
4.1 Choice of the ATM	10
4.1.1 Functional subsets	10
4.1.2 Single- and Multi-party testing	10
4.2 Single PCO testing	11
4.2.1 Call Control testing for non-Transit PINX and Protocol Control testing	11
4.2.2 Segmentation and Protocol Discriminator Filter testing	12
4.3 Multiple PCO testing	12
4.3.1 Call Control testing for a Transit PINX	12
4.4 Test Configurations and use of Concurrent TTCN	13
5 Untestable Test Purposes	14
6 Conformance	15
6.1 PCTR conformance	15
6.2 PIXIT conformance	15
6.3 ATS conformance	15
7 ATS Conventions	16
7.1 Short names and abbreviations	16
7.2 Test suite type, ASP type, PDU type and Alias identifiers	17
7.2.1 ASP type identifiers	17
7.2.2 PDU type identifiers	17
7.2.3 Test Suite Type identifiers (Information Elements)	17
7.2.4 Aliases	18
7.3 Identifiers concerning test configuration	18
7.3.1 Test components	18
7.3.2 Test component configurations	18
7.3.3 Points of Control and Observations (PCOs)	18
7.3.4 Co-ordination Points (CPs)	18
7.3.5 CM types	18
7.4 Test Suite Parameter and Selection Expression identifiers	19
7.4.1 Test suite parameters	19
7.4.2 PICS Parameters	19
7.4.3 PIXIT parameters	19
7.4.4 Test Case Selection Expressions	19
7.4.5 Abbreviations used in PIXIT parameters and Test Case Selection Expressions	20
7.5 Miscellaneous identifiers	21
7.5.1 Test suite operations	21
7.5.2 Test suite constants	21
7.5.3 Test suite variables	21
7.5.4 Test case variables	21
7.5.5 Timers	21
7.6 Constraints	22
7.6.1 TTCN Test suite type constraints	22
7.6.2 ASP constraints	22
7.6.3 PDU constraints	22
7.6.4 CM constraints	22

7.7	Dynamic part	22
7.7.1	Test Case identifiers.....	22
7.7.2	Test Step identifier.....	22
7.7.3	Default identifier.....	23
7.8	Notation.....	23
7.9	Bit and octet order.....	23
8	Test case and test purpose mapping.....	24
Annex A (normative): Partial PIXIT proforma.....		25
A.1	Identification summary	25
A.2	ATS summary	25
A.3	Test laboratory	25
A.4	Client identification	25
A.5	SUT	26
A.6	Protocol layer information	26
A.6.1	Protocol identification	26
A.6.2	IUT information	26
A.6.2.1	General information.....	26
A.6.2.1.1	General Configuration.....	26
A.6.2.1.2	Addressing	27
A.6.2.2	Clearing Procedures.....	28
A.6.2.3	General Sending of Messages.....	28
A.6.2.4	Originating PINX.....	30
A.6.2.5	Terminating PINX	30
A.6.2.6	Incoming Gateway PINX.....	31
A.6.2.7	Outgoing Gateway PINX.....	32
A.6.2.8	Transit PINX.....	32
A.6.2.9	Status Procedure	33
A.6.2.10	Layer Management	33
A.6.2.11	Error Handling.....	33
A.6.2.12	Segmentation	34
A.6.2.13	Timers.....	34
A.6.3	Called Party Numbers in the PIXIT	34
Annex B (normative): Protocol Conformance Test Report (PCTR) Proforma for PSS1_BC		
Layer		36
B.1	Identification summary	36
B.1.1	Protocol conformance test report.....	36
B.1.2	IUT identification.....	36
B.1.3	Testing environment.....	37
B.1.4	Limits and reservation	37
B.1.5	Comments.....	37

B.2	IUT Conformance status	38
B.3	Static conformance summary	38
B.4	Dynamic conformance summary.....	38
B.5	Static conformance review report	38
B.6	Test campaign report.....	39
B.7	Observations.....	46
Annex C (normative): Abstract Test Suite (ATS) for PSS1_BC		47
C.1	The TTCN Graphical form (TTCN.GR).....	47
C.2	The TTCN Machine Processable form (TTCN.MP)	47
Annex D (informative): Compatibility		48
D.1	Other PSS1 protocol specifications	48
D.2	Other connection scenarios	50
D.2.1	Number of channels.....	50
D.2.2	Coding of information elements	50
Annex E (informative): Summary of changes from previous edition		51
E.1	Introduction	51
E.2	Test Suite Structure and Test Case identifier changes.....	51
E.3	Support for multirate	51
E.4	Test Suite Operation and type changes	51
E.5	Review of derivation of TPs	52
E.6	Test suite parameters and test case selection	52
Bibliography		53
History		54

Intellectual Property Rights

IPRs essential or potentially essential to the present document may have been declared to ETSI. The information pertaining to these essential IPRs, if any, is publicly available for **ETSI members and non-members**, and can be found in SR 000 314: "*Intellectual Property Rights (IPRs); Essential, or potentially Essential, IPRs notified to ETSI in respect of ETSI standards*", which is available from the ETSI Secretariat. Latest updates are available on the ETSI Web server (<http://www.etsi.org/ipr>).

Pursuant to the ETSI IPR Policy, no investigation, including IPR searches, has been carried out by ETSI. No guarantee can be given as to the existence of other IPRs not referenced in SR 000 314 (or the updates on the ETSI Web server) which are, or may be, or may become, essential to the present document.

Foreword

This European Standard (Telecommunications series) has been produced by European Computer Manufacturers Association (ECMA) on behalf of its members and those of the European Telecommunications Standards Institute (ETSI), and is now submitted for the Voting phase of the ETSI standards Two-step Approval Procedure.

The present document is part 2 of a multi-part EN covering the Private Integrated Services Network (PISN); Inter-exchange signalling protocol; Circuit mode basic services; Network Layer (NL), as identified below:

Part 1: "Test Suite Structure and Test Purposes (TSS&TP) specification";

Part 2: "Abstract Test Suite (ATS) specification".

Proposed national transposition dates	
Date of latest announcement of this EN (doa):	3 months after ETSI publication
Date of latest publication of new National Standard or endorsement of this EN (dop/e):	6 months after doa
Date of withdrawal of any conflicting National Standard (dow):	6 months after doa

1 Scope

The present document specifies the Abstract Test Suite (ATS) for the Network Layer, Circuit Mode Basic Services of the Inter-exchange signalling protocol, for Private Integrated Services Networks (PISN).

The objective of the present document is to provide conformance tests which give a high probability of inter-operability of the Network Layer. The present document covers the procedures described in EN 300 172 [3] and those parts of EN 301 048 [6] which relate to the use of the transit counter in connection with Basic Call procedures.

NOTE 1: The parts of EN 301 048 [6] included are those which are equivalent to ETS 300 172 [4] annex ZB.

NOTE 2: The ATS in the present document can also be used for testing equipment implemented according to certain other PSS1 specifications.

The ISO standard for the methodology of conformance testing (ISO/IEC 9646-1 [7], ISO/IEC 9646-2 [8] and ISO/IEC 9646-3 [9]) is used as basis for the test methodology.

The present document is applicable to implementations which support either a Basic Rate or a Primary Rate access interface, or both, operating over a leased line. It is applicable to various PINX roles, i.e. Originating, Terminating, Transit, Incoming/Outgoing Gateway.

NOTE 3: The present document can also be applicable to other scenarios if the scenario concerned does not rely on extensions to the protocol for basic call defined in the mapping specification (e.g. the use of National Standard codepoints in the Bearer Capability IE) or support more than 30 information channels. For scenarios which do not satisfy these conditions some test cases can be unsuitable and/or require modifications.

Annex A provides the Partial Protocol Implementation eXtra Information for Testing (PIXIT) Proforma of this specification.

Annex B provides the Protocol Conformance Test Report (PCTR) Proforma of this specification.

Annex C provides the Tree and Tabular Combined Notation (TTCN) part of this specification.

2 References

The following documents contain provisions which, through reference in this text, constitute provisions of the present document.

- References are either specific (identified by date of publication, edition number, version number, etc.) or non-specific.
- For a specific reference, subsequent revisions do not apply.
- For a non-specific reference, subsequent revisions do apply.
- A non-specific reference to an ETS shall also be taken to refer to later versions published as an EN with the same number.

- [1] ECMA-143 (1997): "Private Integrated Services Network (PISN) - Circuit Mode Bearer Services - Inter-Exchange Signalling Procedures and Protocol (QSIG-BC)".
- [2] ECMA-225 (1997): "Private Integrated Services Network (PISN) - Inter-Exchange Signalling Protocol - Transit Counter Additional Network Feature (QSIG-TC)".
- [3] ETSI EN 300 172 (V1.4): "Private Integrated Services Network (PISN); Inter-exchange signalling protocol; Circuit-mode basic services [ISO/IEC 11572 (1996) modified]".
- [4] ETSI ETS 300 172: "Private Telecommunication Network (PTN); Inter-exchange signalling protocol; Circuit mode basic services".

- [5] ETSI EN 300 805-1 (V1.2): "Private Integrated Services Network (PISN); Inter-exchange signalling protocol; Circuit mode basic services; Network Layer (NL); Part 1: Test Suite Structure and Test Purposes (TSS&TP) specification".
- [6] ETSI EN 301 048 (V1.1): "Private Integrated Services Network (PISN); Inter-exchange signalling protocol; Transit counter additional network feature [ISO/IEC 15056 (1997) modified]".
- [7] ISO/IEC 9646-1 (1994): "Information technology - Open Systems Interconnection - Conformance testing methodology and framework - Part 1: General concepts".
- [8] ISO/IEC 9646-2 (1994): "Information technology - Open Systems Interconnection - Conformance testing methodology and framework - Part 2: Abstract Test Suite specification".
- [9] ISO/IEC 9646-3 (1998): "Information technology - Open Systems Interconnection - Conformance testing methodology and framework - Part 3: The Tree and Tabular Combined Notation (TTCN)".
- [10] ISO/IEC 9646-4 (1994): "Information technology - Open Systems Interconnection - Conformance testing methodology and framework - Part 4: Test realization".
- [11] ISO/IEC 9646-5 (1994): "Information technology - Open Systems Interconnection - Conformance testing methodology and framework - Part 5: Requirements on test laboratories and clients for the conformance assessment process".
- [12] ISO/IEC 11572 (1997): "Information technology - Telecommunications and information exchange between systems - Private Integrated Services Network - Circuit mode bearer services - Inter-exchange signalling procedures and protocol".
- [13] ISO/IEC 15056 (1997): "Information technology - Telecommunications and information exchange between systems - Private Integrated Services Network - Inter-exchange signalling protocol - Transit counter additional network feature".
- [14] ETSI TR 101 101 (V1.1): "Methods for Testing and Specification (MTS); TTCN interim version including ASN.1 1994 support [ISO/IEC 9646-3] (Second Edition Mock-up for JTC1/SC21 Review)".

3 Definitions and abbreviations

3.1 Definitions

For the purposes of the present document, the following terms and definitions apply:

Abstract Test Suite (ATS): see ISO/IEC 9646-1 [7].

final test purpose: see EN 300 805-1 [5].

Implementation Under Test (IUT): see ISO/IEC 9646-1 [7].

incoming call: see EN 300 172 [3].

incoming gateway PINX: see EN 300 172 [3].

Lower Tester (LT): see ISO/IEC 9646-1 [7].

network layer: for the purposes of this ATS the procedures described in EN 300 172 [3].

originating PINX: see EN 300 172 [3].

outgoing call: see EN 300 172 [3].

outgoing gateway PINX: see EN 300 172 [3].

PICS proforma: see ISO/IEC 9646-1 [7].

PIXIT proforma: see ISO/IEC 9646-1 [7].

Point Of Control And Observation (PCO): see ISO/IEC 9646-1 [7].

preceding PINX: see EN 300 172 [3].

Protocol Implementation Conformance Statement (PICS): see ISO/IEC 9646-1 [7].

Protocol Implementation Extra Information For Testing (PIXIT): see ISO/IEC 9646-1 [7].

segmentation: see EN 300 805-1 [5].

Signalling Carriage Mechanism (SCM): see EN 300 172 [3].

subsequent PINX: see EN 300 172 [3].

super test purpose: see EN 300 805-1 [5].

System Under Test (SUT): see ISO/IEC 9646-1 [7].

terminating PINX: see EN 300 172 [3].

transit PINX: see EN 300 172 [3].

Upper Tester (UT): see ISO/IEC 9646-1 [7].

3.2 Abbreviations

For the purposes of the present document, the following abbreviations apply:

ANF-TC	Transit Counter Additional Network Feature
ASP	Abstract Service Primitive
ATM	Abstract Test Method
ATS	Abstract Test Suite
CM	Co-ordination Message
CP	Co-ordination Point
IE	Information Element ISO International Organization for Standardization
IUT	Implementation Under Test
LT	Lower Tester
MOT	Mean Of Testing
MSB	Most Significant Bit
MTC	Master Test Component
PCO	Point of Control and Observation
PCTR	Protocol Conformance Test Report
PDU	Protocol Data Unit
PICS	Protocol Implementation Conformance Statement
PINX	Private Integrated Services eXchange
PISN	Private Integrated Services Network
PIXIT	Protocol Implementation eXtra Information for Testing
PSS1 or QSIG	Private Integrated Signalling System Number 1
PTC	Parallel Test Component
SCM	Signalling Carriage Mechanism
SUT	System Under Test
TC	Test Case
TP	Test Purpose
TSO	Test Suite Operation
TTCN	Tree and Tabular Combined Notation
UT	Upper Tester

4 Abstract Test Method (ATM)

This clause describes the different Abstract Test Methods (ATM) used for testing the Network Layer protocol. Two methods are applied: the Remote single layer test method, and the Multi-Party test method.

4.1 Choice of the ATM

4.1.1 Functional subsets

The choice of functional subsets is based primarily on the fact that PSS1 is subdivided into two functional entities:

- Call Control;
- Protocol Control.

Each of these two functional entities is tested using different sets of Test Purposes and hence different Test Cases.

The Protocol Control entity is further divided into three sublayers:

- the Protocol Discriminator Filter sublayer;
- the Message Segmentation sublayer;
- the Other Protocol Control Functions sublayer.

From the viewpoint of this ATS, PSS1 is considered to be divided into two functional subsets, as shown in figure 1. The first of these functional groups consists of the Protocol Discriminator Filter sublayer and the Message Segmentation sublayer. The second functional group consists of the Other Protocol Control Functions sublayer and the Call Control entity. A different PCO is used for each of these functional groups when being tested.

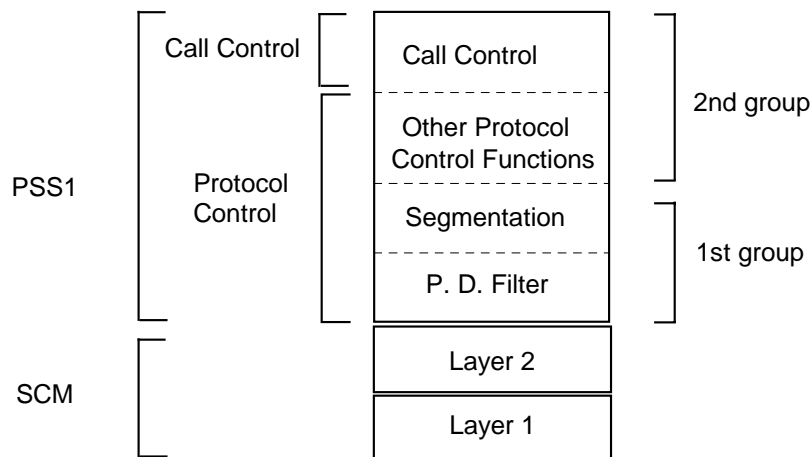

NOTE: In the remainder of clause 4, the term "Protocol Control" refers only to the "Other Protocol Control Functions" sublayer.

Figure 1: PSS1 functional subsets

4.1.2 Single- and Multi-party testing

For Call Control, the protocol defines different roles that a PINX can play: it can be an end or gateway PINX (Originating, Terminating, Incoming Gateway, Outgoing Gateway), or a Transit PINX. In the first case, only one interface needs to be tested, and in the second case, two interfaces need to be tested simultaneously.

4.2 Single PCO testing

Single PCO testing applies to the Segmentation and Protocol Discriminator Filter, to the Protocol Control, and to the Call Control for an Originating, Terminating, Incoming Gateway or Outgoing Gateway PINX.

4.2.1 Call Control testing for non-Transit PINX and Protocol Control testing

As shown in figure 2, the IUT is the Protocol Control and Call Control part, and it is an end-system. It is not possible to observe and control the upper service boundary of the IUT. Consequently, the test method chosen is the Remote Test Method, where the co-ordination procedures are expressed in an informal way. The test system will only contain one LT and no UT. The PCO, called LX, is located between the Protocol Control and Call Control part, and the Segmentation part. Only unsegmented Protocol Data Units (PDUs) are exchanged.

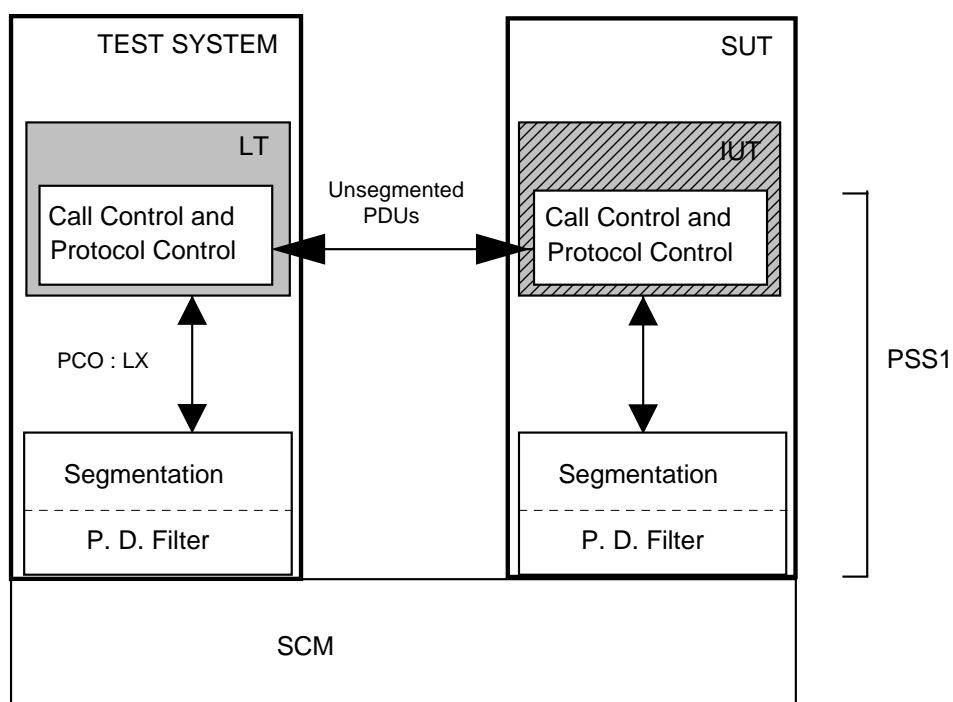

Figure 2: Remote single layer test method for Protocol Control and Call Control for non-Transit PINX

4.2.2 Segmentation and Protocol Discriminator Filter testing

As shown in figure 3, the IUT is the Segmentation and Protocol Discriminator Filter part, and it is an end-system. It is not possible to observe and control the upper service boundary of the IUT. Consequently, the test method chosen is the Remote Test Method, where the co-ordination procedures are expressed in an informal way. The test system will only contain one LT and no UT. The PCO, called LSEG, is located between the Segmentation and Protocol Discriminator Filter part, and the SCM. The PDUs exchanged are SEGMENT PDUs and unsegmented PDUs.

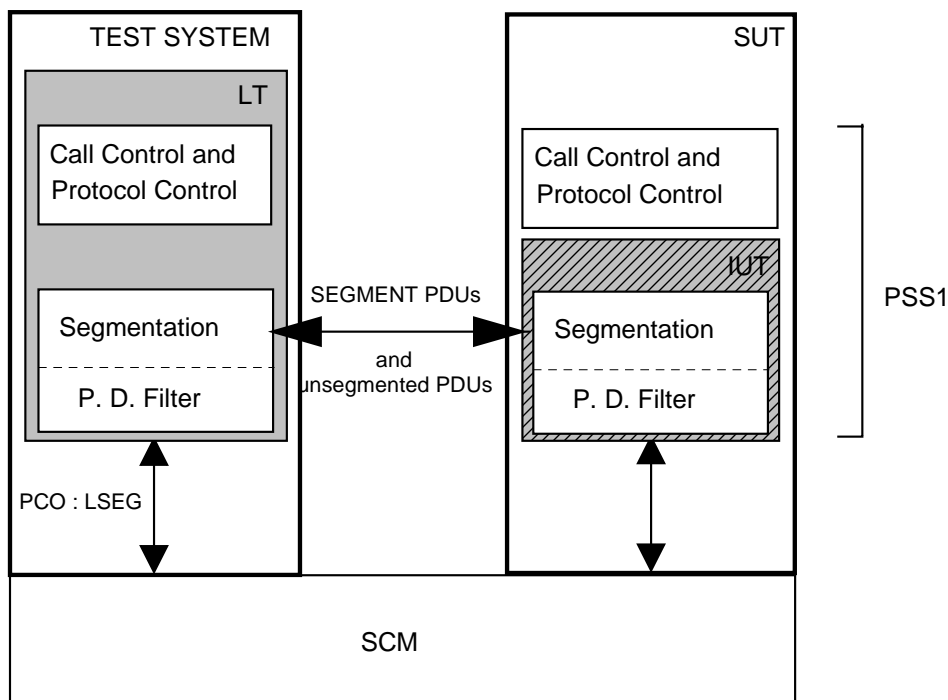

Figure 3: Remote single layer test method for Segmentation and Protocol Discriminator Filter

4.3 Multiple PCO testing

Multiple PCO testing applies to the Protocol Control and the Call Control for Transit PINX.

4.3.1 Call Control testing for a Transit PINX

As shown in figure 4, the IUT is the Protocol Control and Call Control part of the Transit PINX, and it is an open-relay system. Consequently, the test method chosen is a Multi-Party Test Method with no UT. The test system will contain two LTs attached to the IUT via two PCOs, called LX and LY between the Protocol Control and Call Control part, and the Segmentation part. The PDUs exchanged are only unsegmented PDUs.

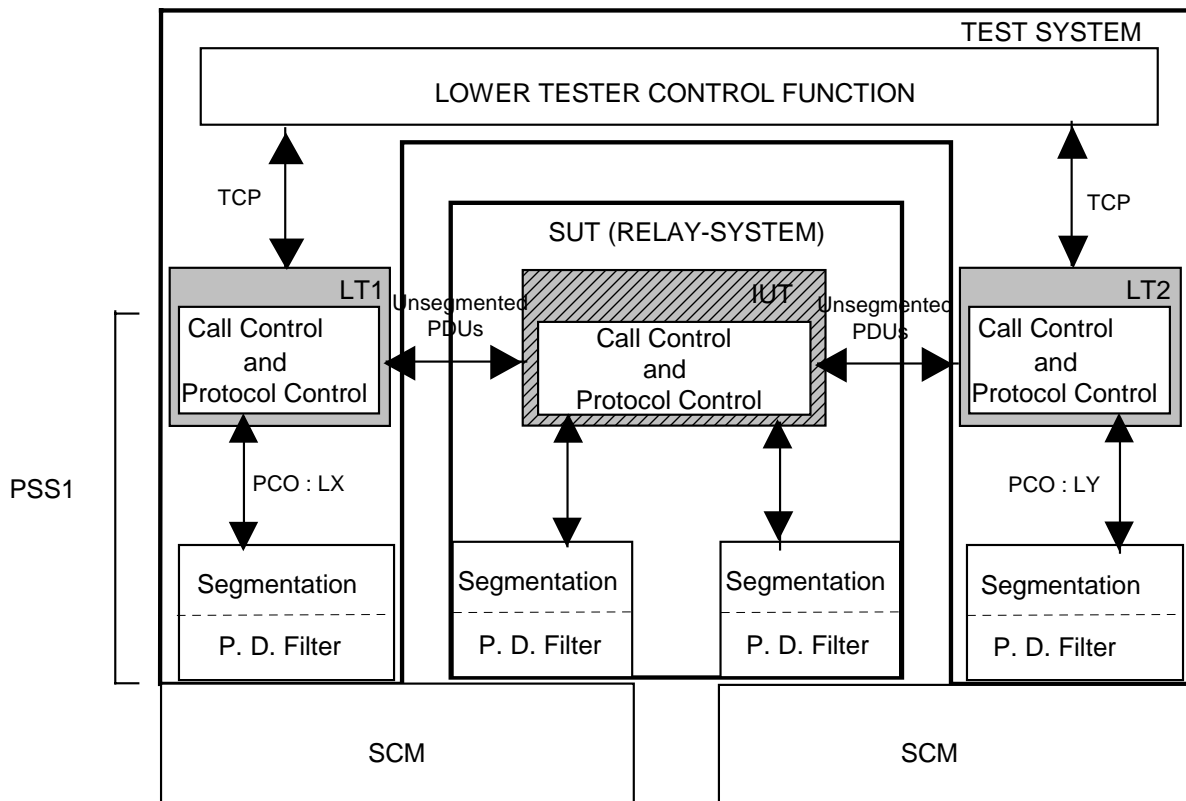

Figure 4: Multi-party test method for Protocol Control and Call Control for Transit PINX

4.4 Test Configurations and use of Concurrent TTCN

As this ATS covers both single-party testing using non-concurrent TTCN, and multi-party testing using concurrent TTCN, the notation chosen for the complete ATS is the concurrent TTCN syntax. Therefore, test components are defined to describe the two configurations: the "mono" configuration and the "transit" configuration, as shown in figures 5 and 6.

The mono configuration is used in case of single-party testing, i.e. for the Protocol Control testing, the Call Control testing for non-transit PINX, and the Segmentation and Protocol Discriminator Filter testing. Only one test component, which is the master test component MTC_MONO, connected to the IUT via the PCOs LX or LSEG, is needed in this case.

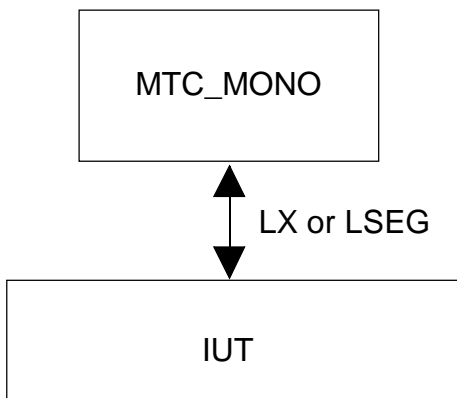

Figure 5: Mono configuration

The transit configuration is used in case of multi-party testing, i.e. for the Protocol Control and Call Control testing for transit PINX. In this case, three test components are needed, these are the Master Test Component MTC_TRANSIT, and the two Parallel Test Components PTC_X and PTC_Y, which are connected to the Master Test Component via the two Co-ordination Points CPX and CPY. PTC_X and PTC_Y are further connected to the IUT via the two PCOs LX and LY.

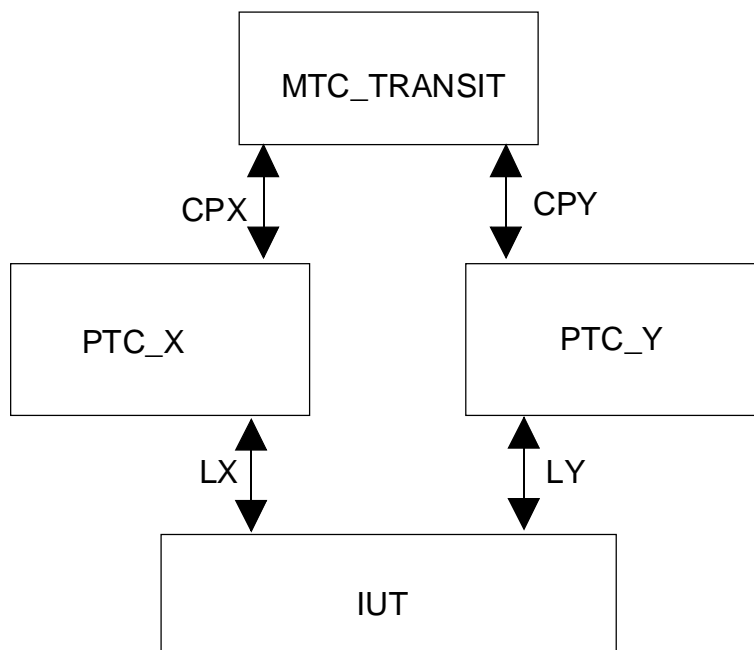

Figure 6: Transit configuration

5 Untestable Test Purposes

Due to the ATMs chosen in this ATS or other restrictions, the following test purposes have been identified as being untestable, and therefore have not been derived into test cases:

- TC002UQ;
- TC002UR;
- TC002UZ;
- TC002UU;
- TC002UV;
- TC002UW;
- TC032UX;
- TC004US;
- TC004UT.

6 Conformance

6.1 PCTR conformance

A test laboratory, when requested by a client to produce a PCTR, is required, as specified in ISO/IEC 9646-5 [11], to produce a PCTR conformant with the PCTR template given in annex B of ISO/IEC 9646-5 [11].

Furthermore, a test laboratory, offering testing for the ATS specification contained in annex C, when requested by a client to produce a PCTR, is required to produce a PCTR conformant with the PCTR proforma contained in annex B.

A PCTR which conforms to this PCTR proforma specification shall preserve the content and ordering of the clauses contained in annex B. Clause B.6 of the PCTR may contain additional columns. If included, these shall be placed to the right of the existing columns. Text in italics may be retained by the test laboratory.

6.2 PIXIT conformance

A test realizer, producing an executable test suite for the ATS specification contained in annex C, is required, as specified in ISO/IEC 9646-4 [10], to produce an augmented partial PIXIT proforma conformant with this partial PIXIT proforma specification.

An augmented partial PIXIT proforma which conforms to this partial PIXIT proforma specification shall, as a minimum, have contents which are technically equivalent to annex A. The augmented partial PIXIT proforma may contain additional questions that need to be answered in order to prepare the Means Of Testing (MOT) for a particular IUT.

A test laboratory, offering testing for the ATS specification contained in annex C, is required, as specified in ISO/IEC 9646-5 [11], to further augment the augmented partial PIXIT proforma to produce a PIXIT proforma conformant with this partial PIXIT proforma specification.

A PIXIT proforma which conforms to this partial PIXIT proforma specification shall, as a minimum, have contents which are technically equivalent to annex A. The PIXIT proforma may contain additional questions that need to be answered in order to prepare the test laboratory for a particular IUT.

6.3 ATS conformance

The test realizer, producing MOT and ETS for this ATS specification, shall comply with the requirements of ISO/IEC 9646-4 [10]. In particular, these concern the realization of an ETS based on each ATS. The test realizer shall provide a statement of conformance of the MOT to this ATS specification.

This specification is applicable to implementations which support either a Basic Rate or a Primary Rate access interface, or both, operating over a leased line. A means of test may offer one or both access types.

An ETS which conforms to this ATS specification shall contain test groups and test cases which are technically equivalent to those contained in the ATS in annex C. All sequences of test events comprising an abstract test case shall be capable of being realized in the executable test case. Any further checking which the test system might be capable of performing is outside the scope of this ATS specification and shall not contribute to the verdict assignment for each test case.

A Means of Test conforming to this ATS shall implement at least a subset of test cases which is the complete subset of test cases selected according to the selection expressions for a particular consistent set of test suite parameters. Such a subset may include only test cases applicable to Transit PINX or End PINX testing.

Test laboratories running conformance test services using this ATS shall comply with ISO/IEC 9646-5 [11].

The test cases concerning information channel selection (TC002BD-BE, TC002BV-CE TC002JD-JG, TC002YM-YQ, TC002YU-ZB) shall be repeated with the IUT configured as A-side and B-side and, if the Channel map is supported, with Channel list and Channel map. The test suite parameter IUT_A shall be set on each run to indicate which side the IUT is configured as. A test laboratory which claims to conform to this ATS specification shall use an MOT which conforms to this ATS.

7 ATS Conventions

This clause describes the conventions adopted in this ATS and gives the naming conventions used for the different ATS elements.

7.1 Short names and abbreviations

Throughout the ATS short names and abbreviations for PDUs and ASPs are used, also abbreviations for Information Elements are used. These are defined in tables 1 to 3.

Table 1: Short names and abbreviations for PDUs

PDU name	Short Name	Abbreviation
ALERTING	ALERTING	ALE
CALL PROCEEDING	CALL_PROC	CPR
CONNECT	CONNECT	CON
CONNECT ACKNOWLEDGE	CONN_ACK	COA
DISCONNECT	DISCON	DIS
FACILITY	FACILITY	FAC
INFORMATION	INFO	INF
NOTIFY	NOTIFY	NOT
PROGRESS	PROGRESS	PRO
RELEASE	RELEASE	REL
RELEASE COMPLETE	REL_COM	RLC
RESTART	RESTART	RES
RESTART ACKNOWLEDGE	REST_ACK	RSA
SETUP	SETUP, SETUPS	SET
SETUP ACKNOWLEDGE	SETUP_ACK	SUA
SEGMENT	SEGMENT	SEG
STATUS	STATUS	STA
STATUS ENQUIRY	STAT_ENQ	STQ
Error PDU (note 1)	ERROR	ERR
Q931 message (note 2)	Q931MSG	Q931
Generic message (note 3)	GENERIC	GEN
NOTE 1: ERROR_PDU is used for incorrectly coded messages sent by the tester which do not have the correct structure for any valid message type.		
NOTE 2: Q931MSG is used to receive any message without examining its contents.		
NOTE 3: GENERIC is used for messages received by the tester where the message type may vary but it is necessary to examine the contents of the message.		

Table 2: Short names and abbreviations for ASPs

ASP name	Short name	Abbreviation
DL-DATA-REQUEST	DL_DAT_REQ	DLRQ
DL-DATA-INDICATION (note)	DL_DAT_IND	DLIN
DL-ESTABLISH-REQUEST	DL_EST_REQ	DERQ
DL-ESTABLISH-INDICATION	DL_EST_IND	DEIN
DL-ESTABLISH-CONFIRM	DL_EST_CON	DECO
DL-RELEASE-REQUEST	DL_REL_REQ	DRRQ
DL-RELEASE-INDICATION	DL_REL_IND	DRIN
DL-RELEASE-CONFIRM	DL_REL_CON	DRCO
NOTE: DLIN_SEG is used as DL-DATA-INDICATION for segmentation.		

Table 3: Abbreviations for Information Elements

Information Element name	Abbreviation
Protocol discriminator	PD
Call Reference	CR
Message type	MT
Sending complete	SC
Locking shift (note 1)	LS
Bearer capability	BCAP
Cause	CAU
Called party number	CDPN
Called party subaddress	CDPS
Calling party number	CGPN
Calling party subaddress	CGPS
Channel identification	CHI
Connected number	CNDN
Connected subaddress	CNDS
Call state	CST
High layer compatibility	HLC
Low layer compatibility	LLC
Notification indicator	NOT
Party category	PC
Progress indicator (note 2)	PI, PIs
Restart indicator	RI
Segmented message	SM
Transit counter	TC
Unspecified IE (note 3)	UNSP
NOTE 1: LS4 and LS5 are used as the abbreviations for locking shift to codesets 4 and 5.	
NOTE 2: PIs is used for multiple progress indicator.	
NOTE 3: UNSP is used where an IE sent to the IUT does not have the structure of any valid IE.	

7.2 Test suite type, ASP type, PDU type and Alias identifiers

7.2.1 ASP type identifiers

The identifier of an ASP is the short name of the ASP.

EXAMPLE: **DL_DAT_REQ** is the DL-DATA-REQUEST ASP.

7.2.2 PDU type identifiers

The identifier of a PDU type is the short name of the PDU.

EXAMPLE: **DISCON** is the DISCONNECT PDU.

7.2.3 Test Suite Type identifiers (Information Elements)

The identifier of a test suite type describing a single information element is the abbreviation for the IE with the suffix "_TYP".

EXAMPLE 1: **BCAP_TYP** is the Bearer capability IE type.

The identifier for a type describing an invalid variant of an IE is the abbreviation for the IE with the suffix "_TYP_BAD".

EXAMPLE 2: **CR_TYP_BAD** is a type for an invalid Call Reference IE.

The element (Field) names used within structured types which describing Information Elements (IEs) consist of the abbreviation for the IE followed by an underscore, followed by, in abbreviated form, and in lower case, the name of the relevant field.

EXAMPLE 3: **BCAP_codstd** is the Coding Standard Field type of the Bearer Capability IE.

7.2.4 Aliases

Aliases are used in the ATS to show which PDU is being sent or received within an ASP. The identifiers for aliases consist of the short name of the PDU, with the suffix "rq" used in aliases for DL_DAT_REQ (PDUs sent by the tester) and the suffix "in" used in the case of aliases for DL_DAT_IND (PDUs received by the tester).

EXAMPLE: **CONN_ACKrq** is an alias for DL_DAT_REQ used for sending a CONNECT ACKNOWLEDGE message.

7.3 Identifiers concerning test configuration

7.3.1 Test components

The name of an Master Test Component (MTC) is composed of the prefix "MTC_", followed by a string in upper case identifying the function of the MTC.

EXAMPLE 1: **MTC_MONO** is the Master Test Component used in the mono configuration.

The name of a Parallel Test Component (PTC) is composed of the prefix "PTC_", followed by an upper case letter indicating which interface the PTC controls.

EXAMPLE 2: **PTCX** is the Parallel Test Component representing the X interface of the IUT.

7.3.2 Test component configurations

The name of a configuration is composed of the prefix "Config_", followed by a name indicating the function of the configuration. The first letter of this name is in upper case and the remainder in lower case.

EXAMPLE: **Config_Transit** is used for transit configuration.

The two figures in subclause 4.4 show a logical view of the configurations used.

7.3.3 Points of Control and Observations (PCOs)

The Point of Control and Observation identifiers are composed of "L" (for Lower tester) followed by an upper case letter indicating the interface that the PCO is connected to.

EXAMPLE: **LX** is the PCO on interface X in the LT.

7.3.4 Co-ordination Points (CPs)

The Co-ordination Point identifiers are composed "CP" followed by an upper case letter indicating the PTC the CP communicates with. (All CPs used are between the MTC and one PTC).

EXAMPLE: **CPX** is a Co-ordination Point between the MTC_TRANSIT component and the PTCX component.

7.3.5 CM types

The identifier of a Co-ordination Message type is a string in upper case.

EXAMPLE: **READY** is a CM used to request if, or to indicate that, a PTC is ready

7.4 Test Suite Parameter and Selection Expression identifiers

7.4.1 Test suite parameters

Two categories of test suite parameters can be distinguished as follows:

- **PICS category:** those derived from the PICS proforma questions;
- **PIXIT category:** those derived from the PIXIT proforma questions.

and the latter can be further subdivided into the following parts:

- PIXIT values: parameters concerning the protocol itself;
- Configuration parameters: parameters concerning the IUT configuration:
 - Values: Values used within test cases;
 - Boolean: Parameters indicating if the corresponding value is available.

All the PICS parameters and PIXIT parameters of the PIXIT values are Boolean. The types of the Configuration Values depend on the type of information represented by the parameter.

The identifier of the test suite parameter depends on whether it is a PICS or PIXIT parameter. In each case it starts with a prefix identifying the category.

7.4.2 PICS Parameters

The identifiers of PICS parameters start with the prefix "PC_" followed by the reference of the item in the relevant PICS.

EXAMPLE: PC_B3 relates to item B3 in the Basic Call PICS "Is the implementation capable of functioning as a Transit PINX?".

7.4.3 PIXIT parameters

The identifiers of PIXIT parameters in the PIXIT values, Configuration values and Boolean value categories start with the prefix "PX_", "tsp_" or "CO" respectively. This is followed by a string of abbreviations, separated by underscores, describing the meaning of the parameter as described in subclause 7.4.5.

EXAMPLE 1: PX_S0_isSET is a parameter meaning "Does the IUT support implicit sending of SETUP in state 0".

EXAMPLE 2: tsp_InvNum1 is a parameter meaning "A number which the IUT can determine to be invalid".

EXAMPLE 3: CO_Cnum is a parameter meaning "Is a number which the IUT can determine to be complete available".

7.4.4 Test Case Selection Expressions

The identifiers of Test Case Selection Expressions consist of a string of abbreviations, separated by underscores, describing the meaning of the parameter as described in subclause 7.4.5.

EXAMPLE: TR_ENT_TCC1 is a selection expression meaning when true "The IUT, as a transit PINX, can enter state TCC1".

7.4.5 Abbreviations used in PIXIT parameters and Test Case Selection Expressions

The abbreviations used in the PIXIT parameters and Test Case Selection Expressions are defined in table 4. While it is possible to see from these abbreviations the approximate meaning of the parameter or expression it is necessary to refer to the appropriate table in the TTCN ATS or the referenced PIXIT question to determine the exact meaning.

Table 4

Abbreviation	Meaning
OC, Out_Call	Outgoing call
IC, In_Call	Incoming call
TR	Transit PINX
TE	Terminating PINX
OI	Originating PINX
OG	Outgoing Gateway PINX
IG	Incoming Gateway PINX
ENT	Enters state
UN	Unstable
S8 etc.	State 8. etc. (If this is the last component it means that the IUT can enter and is stable in the specified state. If it is followed by a message it means that the IUT can send the message in the specified state).
T304 etc.	Timer T304etc. implemented
no	Number
rel	Relays
REL etc.	IUT can send RELEASE message etc. (Message abbreviations are as defined in table?).
iREL etc.	Implicit send of RELEASE possible etc.
iCLEAR	Implicit clearing possible
imp	Feature is implemented
retr	Retransmits
onUNREC	IUT sends message on receiving unrecognized message
onDLestCON	IUT sends message on DL_ESTABLISH_CONFORM
TC	IUT supports transit counter functions
TCinclude	IUT includes transit counter IE
TClimit	Limit for Transit Counter value
Ta	Tones and Announcements associated with Call Clearing
PI etc.	Including Progress Indicator IE etc. (IE abbreviations are as defined in table 3
pref, excl	Preferred, Exclusive (Values of Preferred/Exclusive bit)
unres, speech, audio, udi_ta	Unrestricted Digital Info, Speech, 3.1kHz Audio, UDI with Tones & announcements (Bearer Capabilities)
Bcap	Bearer Capability IE
NoCLIR	Without the Calling/Connected Line Identification Restriction supplementary service being invoked.
Echnum, Echnum2	Valid channel numbers
Nechnum	Invalid channel number
NoChans	Number of channels available
Cnum	"Complete Number": a number which the IUT can determine to be complete
Fnum	"Full Number": a number which is complete in the numbering plan implemented in the IUT and which the IUT may, or may not, determine to be complete.
Inum	"Incomplete number" a number which the IUT can determine to be incomplete.
Onum	"Overlap number": a number which the IUT cannot determine to be complete (i.e. causes it to use overlap receiving) this is referred to as a Partial Number in the PIXIT.
Rnum	"Routing Number": a Partial number such that the IUT can determine which role is applicable (terminating, transit or outgoing gateway) and, if the role is transit, cause a SETUP to be sent on the outgoing inter-PINX link.
NRnum	"Non-Routeable Number" is a number is insufficient for the IUT (a transit PINX) to determine is to be routed on a particular inter-PINX link, but may, with the addition of further digits, so be routed.
InvNnum	"Invalid Number": an number which the IUT can determine to be unassigned in the numbering plan that it is configured for.
Tnum	"Timer Number": a full number which the IUT cannot determined to be complete (in the absence of Sending complete) until expiry of T302

Abbreviation	Meaning
sXYnum	Supplementary X-Y number (X and Y can be C, F, O, R or NR representing Complete, Full, Partial (overlap), Routing or non-Routing). This is a number which when concatenated to the number given as an "X number" produces a "Y number".
Cnum1 etc. Pre Tester_NumDigits Parts time len	First part of Cnum etc. Preceding PINX Number of terminal attached to tester as seen by IUT Number can be divided in parts time (duration) Length

7.5 Miscellaneous identifiers

7.5.1 Test suite operations

The Test Suite Operation identifiers are composed of string in lower case separated by underscore characters ('_').

EXAMPLE: **find_chnum** is used to check if a channel number exists into a list of information channel numbers.

7.5.2 Test suite constants

The Test Suite Constant identifiers begin with the prefix 'C_', followed by a string identifying the function of the constant. Where the constant represents the value of the message type for a specific message the string consists of "MT" (the abbreviation for the Message Type IE) followed by the abbreviation for the specific message. In other cases the string starts with the abbreviation for the appropriate IE and there is no restriction in the characters in the remainder of the string.

EXAMPLE: **C_MTCOA** is the **Message Type** IE value of a **CONNECT ACK** message.

7.5.3 Test suite variables

No Test Suite Variables have been used in the ATS.

7.5.4 Test case variables

The Test Case Variable identifiers begin with the prefix "CV_", followed by a string with no restriction on the type of characters.

EXAMPLE: **CV_CRVALUE** is a Call Reference Value used by one call between the IUT and the tester.

7.5.5 Timers

The identifier for a test suite timer derived from a protocol timer defined in EN 300 172 [3] is the name of the timer from the base standard with the suffix "_max" or "_min" to indicate the minimum or maximum duration of the timer.

EXAMPLE 1: **T313_max** is a test suite timer corresponding to the maximum duration of the protocol timer T313.

The identifiers for other timers (e.g. those used while waiting for a response from the IUT) consist of "T_" followed by a name in upper case.

EXAMPLE 2: **T_REST** is a timer for the response of the IUT to a RESTART message.

7.6 Constraints

7.6.1 TTCN Test suite type constraints

Test suite type constraint identifiers consist of the abbreviation for the IE followed by two digits for a valid constraint or one upper case letter (X or Y) and one digit for an erroneous constraint.

EXAMPLE 1: **CHI01** is a constraint for the Channel Identification IE.

EXAMPLE 2: **CAUX1** is a constraint of the Cause test suite type containing an error (reserved value of location).

7.6.2 ASP constraints

The identifier for an ASP constraint is the abbreviation for the ASP. (There is never more than one constraint for each ASP).

EXAMPLE 1: **DLRQ**, is a generic constraint for the DL_DAT_REQ primitive, for sending any PDU to the IUT.

EXAMPLE 2: **DLIN**, is a generic constraint for the DL_DAT_IND primitive for receiving any PDU from the IUT.

7.6.3 PDU constraints

PDU constraint identifiers consist of the abbreviation for the PDU followed by two digits for a valid constraint or one upper case letter (X or Y) and one digit for an erroneous constraint. The last digit is odd for constraints for messages sent by the tester and even for constraints for messages received by the tester.

EXAMPLE 1: **ALEX7** indicates a constraint for an ALERTING message containing an error (invalid Party Category IE contents) which is to be sent to the IUT.

EXAMPLE 2: **ALE02** indicates a constraint for a valid ALERTING message which has been received from the IUT.

7.6.4 CM constraints

The identifier of a Co-ordination Message constraint is an abbreviation of the CM type in upper case.

EXAMPLE: **RDY** is a constraint of the READY Co-ordination Message.

7.7 Dynamic part

7.7.1 Test Case identifiers

The TC identifiers are the same as the corresponding TP identifier. This is in the form TCxxxxy where xxx is a three digit code identifying the test group and yy is a two letter code uniquely identifying the TC.

7.7.2 Test Step identifier

The Test Step identifier is a string in lower case consisting of one or more components separated by underscore characters ('_').

The following components may appear in test step identifiers in this order:

"pre"	Preamble
"check_state"	Check state
"check_2state"	Check state with two alternative states
"post"	Postamble
"passive"	Test step run on interface which is not the focus of a transit test case

"receive"	Test step for receiving a message (e.g. segmented)
"mtc", "ptcx" or "ptcy"	Test component (for synchronization test steps)
"tr"	Transit test step (in some cases this is implied from the presence of x or y)
"seg", "lseg"	Test step for PCO LSEG
"status_enq"	Test step to cause IUT to send a STATUS ENQUIRY
"clear"	Test step to clear the call from one side of a transit PINX
"x" or "y"	Interface the test step is run on (implies transit)
"s0", "s1" etc.	End call state of test step
"rest1"	End layer management state of the test step
"a"	No synchronization at end of test step (transit only)

NOTE: There is no underscore separating "x" or "y", the state and "a".

"ic"	Incoming call
"oc"	Outgoing call
"excl"	Exclusive (Channel identification)
"pref"	Preferred (Channel identification)
"busy_chan"	Make channel(s) busy
"param"	Parameterized
"sync"	Synchronize (only)

EXAMPLE 1: **pre_tr_xs25** indicates that this test step is a preamble used in the transit test cases, to bring interface X to state 25.

EXAMPLE 2: **check_state_y** indicates that this test step is used to check that the interface Y of the IUT is in a particular state.

7.7.3 Default identifier

The Default identifiers begin with the prefix "def_", followed by a string in lower case, representing the place where the default tree is used.

EXAMPLE 1: **def_steps** is the general default tree for the test steps.

EXAMPLE 2: **def_post** is the default tree for the postambles.

EXAMPLE 4: **def_pre_x** is the default tree for the transit preambles occurring on interface X.

EXAMPLE 5: **def_mtc** is the default tree for the transit test cases, describing the behaviour of the Master Test Component.

7.8 Notation

The version of TTCN used is that defined in TR 101 101 [14].

7.9 Bit and octet order

The conventions for bit numbering are different in TTCN and the definition of QSIG PDUs in EN 300 172 [3]. In the TTCN type BITSTRING bit 0 is the most significant (leftmost) bit of a string whereas in QSIG bit 1 is the least significant (rightmost) bit of an octet.

Where the BITSTRING type is used to represent a QSIG PDU, information element or field bit 0 represents the MSB (of the first octet) of the PDU, IE or field.

NOTE: This is likely to differ from the bit order of the received PDU.

Where the OCTETSTRING type is used to represent a QSIG information element or field octet 0 is the first octet of the IE or field.

8 Test case and test purpose mapping

There is a one-to-one mapping between the test cases and the final derived test purposes in EN 300 805-1 [5], and they both have the same identifier.

Annex A (normative): Partial PIXIT proforma

Notwithstanding the provisions of the copyright clause related to the text of the present document, ETSI grants that users of the present document may freely reproduce the PIXIT proforma in this annex so that it can be used for its intended purposes and may further publish the completed PIXIT.

The PIXIT Proforma is based on ISO/IEC 9646-5. Any additional information needed can be found in that international standard document.

A.1 Identification summary

PIXIT Number:	
Test Laboratory Name:	
Date of Issue:	
Issued to:	

A.2 ATS summary

Protocol Specification:	EN 300 172 and EN 301 048 (Basic Call part)
Protocol to be tested:	PSS1, Circuit Mode Basic Services
ATS Specification:	EN 300 805-2
Abstract Test Method for the Message Segmentation and the Protocol Discriminator Filter:	Embedded variant of the Remote Test Method with no UT
Abstract Test Method for Transit Call Control:	Multi-Party Test Method with no UT
Abstract Test Method for non-Transit Call Control and Other Protocol Control Functions:	Remote Test Method

A.3 Test laboratory

Test Laboratory Identification:	
Test Laboratory Manager:	
Means of Testing:	

A.4 Client identification

Client Identification:	
Client Test manager:	
Test Facilities required:	

A.5 SUT

Name:	
Version:	
System Conformance Statement Number:	
Machine configuration:	
Operating System Identification:	
IUT Identification:	
PICS Reference for IUT:	EN 300 172 annex A EN 301 048 annex A
Limitations of the SUT:	
Environmental Conditions:	

A.6 Protocol layer information

A.6.1 Protocol identification

Name:	PSS1 Circuit Mode Basic Services (QSIG-BC)	PSS1 Transit Counter Additional Network Feature (ANF-TC) basic call part
Version:		
PICS References:	EN 300 172 annex A	EN 301 048 annex A
Supported	Yes	

A.6.2 IUT information

NOTE 1: For numbers sent by the IUT, only the digit fields of the Called Party Number are required.

NOTE 2: For numbers sent to the IUT, the complete Called Party Number IE should be supplied.

A.6.2.1 General information

A.6.2.1.1 General Configuration

One interface of the IUT should be designated X, this interface is used for all non-transit test cases and is used for the incoming side for Transit test cases. If the IUT is a transit PINX then another interface should be designated Y, this is used for the outgoing side of Transit tests.

Table A.1: General Configuration

Item	Action	Action Possible?/ Item Supported? Y/N	Action taken/Value
1	How can the IUT be configured as A side?		
2	How can the IUT be configured as B side?		
3	How many Information channels does the IUT support on each interface?		
4	Specify the numbers of two supported information channels.		
5	Specify the number of one information channel which is not supported.		
6	Specify a valid Bearer Capability IE.		
7	Specify how to identify interface X.		
8	Specify how to identify interface Y.		
9	Does the IUT re-transmit SETUP on expiry of T303?		
10	Is it possible, with the IUT as it is configured for testing, for all B-channels to be made busy?		

A.6.2.1.2 Addressing

For each of the roles Terminating, Transit and Outgoing gateway which the IUT supports one or more appropriate numbers should be specified. For a terminating PINX this should be the number of a terminal attached to the IUT, for a transit PINX it should be a number routed on to interface Y and for an outgoing gateway it should be a number routed to the other network. In addition valid numbers are required for Protocol Control tests (which may be the same as that for one or more of the roles) including an unassigned number.

In each case the numbering plan identifier (column "NPI"), type of number (column "TON") and number of digits should be given in tables A.2 (columns A to D) and A.2A (columns A & B). The number of digits should be entered into columns (excluding those which are shaded) such that the description of the number in the heading of each column is satisfied by the number formed by the digits in that column and the columns to the left of it, (i.e. each column except the leftmost contains digits to be appended to those in the columns to the left.). Depending on the numbering plan some columns may be empty, however as many columns as possible should be filled and at least one entry in column D (for table A.2) is required for each supported role and any entry should be made in each box where a symbol indicates that an entry is required. The number supplied in table A.2A row 6 should be different from that in row 5 (when the tester makes two calls at the same time these numbers are used).

Table A.2 is used for call control test.

Table A.2A is used for protocol control tests.

Table A.2: Addressing (part 1)

	Role	NPI	TON	A Not routable	B Routable	C Routable	D Full	E Determined complete (Y/N)
1	Terminating						*	
2	Transit				#		*	No (Yes)
3	Transit				@		@	No Yes
4	Outgoing						*	(No)

Table A.2A: Addressing (part 2)

	Description	NPI	TON	A Partial	B Full	C Determined complete (Y/N)
5	Valid			+	*	(Yes)
6	Valid				\$	
7	Determined incomplete					No
8	Not determined complete					No
9	Unassigned			+	+	Yes

- * always required.
+ required if overlap receiving is to be tested.
required if overlap receiving to be tested and overlap sending supported.
\$ required if Multirate or sending of RESTART supported.
@ only required if it is possible to supply a value for A.2/3A.
(Yes)/(No) If possible the number supplied should be such that the answer to this item is Yes or No as indicated.
Yes/No The number shall be chosen such that the answer to the item is Yes or No as indicated. If this is not possible then no answer to the item completing the number in this row is required.

If an item indicated as required is omitted this can result in test cases which are applicable to the IUT being impossible to run.

Table A.3: Addressing - supplementary information

Item	What is the Party Category, if supported, associated with the number specified in table A.2 above for the IUT as a...	Item Supported? Y/N	Value
1	Terminating PINX.		
2	Outgoing gateway PINX.		

A.6.2.2 Clearing Procedures

Table A.4: Clearing Procedures

Item	Action What actions, if possible, have to be taken to initiate call clearing,...	Action Possible? Y/N	Action taken
1	...in state 1?		
2	...in state 2?		
3	...in state 3?		
4	...in state 4?		
5	...in state 7?		
6	...in state 8?		
7	...in state 9?		
8	...in state 10?		
9	...in state 25?		

A.6.2.3 General Sending of Messages

NOTE 1: Where a question refers to certain information elements being present in a message this does not imply that other IEs may not be present. If any are sent then they will be ignored.

NOTE 2: If a message is sent automatically in a particular state, then this should be stated in the question concerned with the sending of that message, with the time taken included.

Table A.5: Sending of SETUP Message

Item	Action Sending of SETUP What actions, if possible, have to be taken to cause the IUT, as an Originating or Incoming Gateway PINX, to send a SETUP message...	Action Possible? / Item Supported? Y/N	Action taken/Value
1	...without any restriction on which optional IEs are present?		
2	...containing a Sending Complete IE?		
3	...containing a Channel Identification IE with Preferred/Exclusive field encoded as preferred?		
4	...containing a Channel Identification IE with Preferred/Exclusive field encoded as exclusive?		
5	...containing a Called Party Number IE not containing a complete number, but with further address information available for use in overlap sending?		
6	...containing a Bearer Capability IE encoded for 64 kbit/s Unrestricted Digital Information?		
7	...containing a Bearer Capability IE encoded for 64 kbit/s Speech?		
8	...containing a Bearer Capability IE encoded for 64 kbit/s 3,1 kHz audio?		
9	...containing a Bearer Capability IE encoded for 64 kbit/s unrestricted digital information with tones and announcements?		
10	...containing a Called Party Number IE which contains a complete number?		
11	Specify this complete number sent according to (10).		
12	...containing a Bearer Capability IE encoded for Multirate?		
13	...containing a Bearer Capability IE encoded for A Law?		
14	...containing a Bearer Capability IE encoded for mu Law?		
15	...containing a Bearer Capability IE encoded for Multirate and a Channel ID IE with multiple channels and with Pref/Excl field encoded as exclusive?		
16	...containing a Bearer Capability IE encoded for Multirate and a Channel ID IE with multiple channels and with Pref/Excl field encoded as preferred?		

Table A.6: Sending of ALERTING Message

Item	Action Sending of ALERTING What actions, if possible, have to be taken to cause the IUT, as a Terminating or Outgoing Gateway PINX, to send an ALERTING message...	Action Possible? Y/N	Action taken
1	...without any restriction on which optional IEs are present, in state 9?		
2	...containing a Progress Indicator IE, in state 9?		
3	...without any restriction on which optional IEs are present, in state 25?		

Table A.7: Sending of PROGRESS Message

Item	Action Sending of PROGRESS What actions, if possible, have to be taken to cause the IUT to send a PROGRESS message,...	Action Possible? Y/N	Action taken
1	...in state 7?		
2	...in state 9?		
3	...in state 10?		
4	...in state 25?		

Table A.8: Sending of CONNECT Message

	Sending of CONNECT What actions, if possible, have to be taken to cause the IUT, as a Terminating or Outgoing Gateway PINX, to send a CONNECT message...	Action Possible? Y/N	Action taken
1	...without any restriction on which optional IEs are present, in state 7?		
2	...without any restriction on which optional IEs are present, in state 9?		
3	...containing a Progress Indicator IE, in state 7?		
4	...containing a Progress Indicator IE, in state 9?		

A.6.2.4 Originating PINX

Table A.9: Originating PINX

Item	Action Sending of SETUP What actions, if possible, have to be taken to cause the IUT, as an Originating PINX, to send a SETUP message...	Action Possible? Y/N	Action taken
1	...without any restriction on which optional IEs are present?		
2	...containing a Calling Party Subaddress IE?		
3	...containing a Called Party Subaddress IE?		
4	...containing a Low Layer Compatibility IE?		
5	...containing a High Layer Compatibility IE?		
6	...without the Calling/Connected Line Identification Restriction supplementary service invoked?		
7	...containing a Transit Counter IE?		
8	...containing a Party Category IE?		

A.6.2.5 Terminating PINX

Table A.10: Sending of ALERTING

Item	Action Sending of ALERTING What actions, if possible, have to be taken to cause the IUT, as a Terminating PINX, to send an ALERTING message...	Action Possible? Y/N	Action taken
1	...containing a Party Category IE, in state 9?		

Table A.11: Sending of CONNECT

Item	Action Sending of CONNECT What actions, if possible, have to be taken to cause the IUT, as a Terminating PINX, to send a CONNECT message...	Action Possible? Y/N	Action taken
1	...without any restriction on which optional IEs are present, in state 7?		
2	...without any restriction on which optional IEs are present, in state 9?		
3	...without the Calling/Connected Line Identification Restriction supplementary service being invoked, in state 7?		
4	...containing a Connected Subaddress IE in state 7?		
5	...containing a Connected Subaddress IE in state 9?		
6	...containing a Lower Layer Compatibility IE in state 7?		
7	...containing a Lower Layer Compatibility IE in state 9?		
8	...containing a Party Category IE in state 7?		
9	...containing a Party Category IE in state 9?		

Table A.12: In-band Tones and Announcements

Item	Action In-band Tones and Announcements generated by the PINX.	Action Possible? / Item Supported? Y/N	Action taken/Value
1	How, if possible, can the IUT, as a Terminating PINX, be caused to generate an in-band tone or announcement associated with call clearing and in which protocol control state(s)?		
2	What is the maximum duration of the in-band tone or announcement associated with call clearing as a Terminating PINX?		

A.6.2.6 Incoming Gateway PINX

Table A.13: Incoming Gateway PINX

Item	Action Sending of SETUP What actions, if possible, have to be taken to cause the IUT, as an Incoming Gateway PINX, to send a SETUP message...	Action Possible? Y/N	Action taken
1	...containing a Called Party Subaddress IE?		
2	...containing a Calling Party Subaddress IE?		
3	...containing a Low Layer Computability IE?		
4	...containing a High Layer Computability IE?		
5	...containing a Sending complete IE?		
6	...containing a Progress Indicator IE?		
7	...containing a Transit Counter IE?		
8	...containing a Party Category IE?		
9	...containing a Calling Party Number IE?		

A.6.2.7 Outgoing Gateway PINX

Table A.14: Sending of ALERTING

Item	Action Sending of ALERTING What actions, if possible, have to be taken to cause the IUT, as an Outgoing Gateway PINX, to send an ALERTING message...	Action Possible? Y/N	Action taken
1	...without any restriction on which optional IEs are present?		
2	...containing a Party Category IE?		

Table A.15: Sending of CONNECT

Item	Action Sending of CONNECT What actions, if possible, have to be taken to cause the IUT, as an Outgoing Gateway PINX, to send an CONNECT message...	Action Possible? Y/N	Value
1	...without any restriction on which optional IEs are present?		

A.6.2.8 Transit PINX

Table A.16: Transit Counter

Item	Action Transit Counter	Item Supported? Y/N	Value
1	What is the acceptable limit of the Transit Counter, or, if it is variable, how can it be set?		
2	Does the implementation include a Transit Counter IE in a SETUP message it sends as a transit PINX if this IE is not present in the incoming SETUP message?		

Table A.17: In-band Tones and Announcements

Item	Action In-band Tones and Announcements generated by the PINX	Action Possible? / Item Supported? Y/N	Action taken/Value
1	How, if possible, can the IUT as a Transit PINX, be caused to generate an in-band tone or announcement associated with call clearing towards the preceding PINX, and in which transit call control state(s)?		
2	What is the maximum duration of the in-band tone or announcement associated with call clearing sent towards the preceding PINX?		
3	Does the IUT send a PROGRESS message associated with Tones and Announcements in state TCC_CallActive?		

Table A.18: Void

A.6.2.9 Status Procedure

Table A.19: Status Enquiry Procedure (Implicit Status Enquiry)

Item	Action STATUS ENQUIRY What actions, if possible, have to be taken to cause the IUT to send a STATUS ENQUIRY message...	Action Possible? Y/N	Value
1	...in state 2?		
2	...in state 3?		
3	...in state 4?		
4	...in state 7?		
5	...in state 9?		
6	...in state 10?		
7	...in state 25?		
NOTE:	Implicit STATUS ENQUIRY is only required in states in which the IUT does not send STATUS ENQUIRY on unrecognized message type (table A.22, item 2) or DL_EST_CON (table A.22, item 1).		

Table A.20: Status Enquiry Procedure (Retransmission)

Item	Action STATUS ENQUIRY	Item Supported? Y/N	Value
1	Does the IUT re-transmit the STATUS ENQUIRY message?		
2	If so what is the maximum number of re-transmissions of a STATUS ENQUIRY message?		

A.6.2.10 Layer Management

Table A.21: Layer Management

Item	Action RESTART	Action Possible? / Item Supported? Y/N	Action taken/Value
1	How, if possible, can the IUT be caused to send a RESTART message?		
2	Does the IUT re-transmit the RESTART message?		

A.6.2.11 Error Handling

Table A.22: STATUS ENQUIRY

Item	Action STATUS ENQUIRY	Item Supported? Y/N	Value
1	Does the IUT always return a STATUS ENQUIRY message on receipt of DL-ESTABLISH-CONFIRM following SCM malfunction in state 10?		
2	Does the IUT always return a STATUS ENQUIRY message on receiving a message with an unrecognized message type?		

A.6.2.12 Segmentation

Table A.23: Segmentation

Item	Action SCM Information Field	Action Possible? Y/N	Value
1	How (if possible) can a SETUP message exceeding the maximum SCM information field length be sent?		

A.6.2.13 Timers

Table A.24: Timers

Item	Action Timers	Item Supported? Y/N	Value
1	What is the maximum duration of Timer T304?		

A.6.3 Called Party Numbers in the PIXIT

This subclause gives some explanations concerning the numbers used in the PIXIT proforma and the Test Suite Parameters used in the TTCN ATS.

For the purposes of the PIXIT and test suite parameters the definitions below apply:

- a "**Full number**" is a number that the IUT cannot determine to need further digits to complete it;
- a "**Partial number**" (or "**Overlap number**" in the ATS) is a number to which further digits can be added to make it a full number;
- a "**Complete number**" is a number with which the IUT can determine is complete;
- an "**Incomplete number**" is a partial number that IUT can determine is not a full number;

NOTE: A number with which the IUT cannot determine to be either complete or incomplete can be considered as both a Full number and Partial number.

- a "**Routing number**" is a Partial number such that the IUT can determine which role is applicable (terminating, transit or outgoing gateway) and, if the role is transit, cause a SETUP to be sent on the outgoing inter-PINX link;
- a "**Non-routeable number**" (Transit PINX) is a partial number such that the IUT can determine that the transit role is applicable but does not cause a SETUP to be sent on the outgoing inter-PINX link;
- an "**Unassigned number**" is a number with which the IUT can determine is unassigned, even if further digits are added (This is by definition a full number).

In some numbering plans the completeness of a number may be meaningless at a Transit or Outgoing Gateway PINX, (e.g. numbers are of variable length and only the terminating PINX, or an exchange in another network has information concerning the length of numbers for its terminals). In these cases a number can be considered as a full number if it has at least the minimum number of digits possible for a number for the appropriate route from the IUT and a partial number if it has less than the maximum number of digits.

EXAMPLE: The numbering plan for a PINX is:

- Terminating : 2XXX (where digits XXX are all assigned);
- Transit → Y : 34XX (where digits XX are all assigned);
- Transit → Z : 35XX (Z is an interface not being tested);

- Outgoing : 9.....;
- Unassigned : All other numbers;
- An example of addressing tables corresponding to this numbering plan is below:

Table A.25: Example of completed A.2

				A	B	C	D	E
	Role	NPI	TON	Not routable	Routable	Routable	Full	Determined complete (Y/N)
1	Terminating	PNP	Unknown		23		45	
2	Transit	PNP	Unknown		34	5		No
3	Transit	PNP	Unknown	3	4		56	Yes
4	Outgoing	Unknown	Unknown				456	No
							98765	No

Table A.26: Example of completed A.2A

	Description	NPI	TON	A	B	C
				Partial	Full	Determined complete (Y/N)
5	Valid	PNP	Unknown	23	45	Yes
6	Valid	PNP	Unknown		3456	
7	Determined incomplete	PNP	Unknown	23		No
8	Not determined complete	PNP	Unknown		98765	No
9	Unassigned	PNP	Unknown	3	999	Yes

- Examples of numbers of various types according to this numbering plan are below:
 - full number: 2345, 3456, 3999, 98765;
 - partial numbers: 23, 34, 345, 35, 98765;
 - complete numbers: 2345, 3456;
 - incomplete numbers: 23, 34, 345, 35;
 - routing numbers: 23, 34, 345, 3456;
 - non-routeable number: 3;
 - unassigned number: 45, 456, 3999.

Annex B (normative): Protocol Conformance Test Report (PCTR) Proforma for PSS1_BC Layer

Notwithstanding the provisions of the copyright clause related to the text of the present document, ETSI grants that users of the present document may freely reproduce the PCTR proforma in this annex so that it can be used for its intended purposes and may further publish the completed PCTR.

The PCTR Proforma is based on ISO/IEC 9646-5. Any additional information needed can be found in that document.

Text in *italics* is for guidance purposes only, and is not to be included in the actual PCTR.

B.1 Identification summary

B.1.1 Protocol conformance test report

PCTR Number:	
PCTR Date:	
Test Laboratory	
Accreditation status:	
Accreditation reference:	
Technical Authority:	
Job Title:	
Signature:	
Test Laboratory Manager:	
Signature:	

B.1.2 IUT identification

Name:	
Version:	
Protocol specification:	Basic call: EN 300 172 ANF-TC: EN 301 048 (basic call part) (see note)
PICS:	Basic call: EN 300 172 annex A Ref. Ref. to attached document. ANF-TC: EN 301 048 annex A Ref. Ref. to attached document. (see note)
NOTE:	If ANF-TC is not supported then the references to EN 301 048 should be deleted. If the IUT is implemented according to different base standards or versions of base standards then the references should be changed appropriately (see annex D).

B.1.3 Testing environment

PIXIT Number:	EN 300 805-2 annex A ref. <i>Ref. to attached doc.</i>
ATS Specification:	EN 300 805-2
Abstract Test Method for the Message Segmentation and the Protocol Discriminator Filter:	Remote test method, Embedded variant with no UT
Abstract Test Method for Transit Call Control:	Multi-Party Test Method with no UT
Transit Call Control and Other Protocol Control Functions:	Remote Test Method
Means of Testing identification:	
Period of testing:	
Conformance Log reference(s):	
Retention Date for Log reference(s):	

B.1.4 Limits and reservation

Additional information relevant to the technical contents or further use of the test report, or the rights and obligations of the test laboratory and the client, may be given here. Such information may include restriction on the publication of the report.

.....

.....

.....

.....

.....

.....

The order of test cases listed in clause 6 of this PCTR corresponds to the ordering of test cases defined in the ATS referenced in subclause 1.3. This does not indicate that the test cases were executed in this order.

The test results presented in this test report apply only to the particular IUT declared in subclause 1.2 of this PCTR, for functionality described in the relevant PICSs attached to this PCTR, as presented for test in the period declared in subclause 1.3 and configured as declared in the relevant PIXITs attached to this PCTR. This PCTR shall not be reproduced except in full together with its attached PICSs and PIXITs.

B.1.5 Comments

Additional comments may be given by either the client or the test laboratory on any of the contents of the PCTR, for example, to note disagreement between the two parties.

.....

.....

.....

.....

B.2 IUT Conformance status

This IUT has/has not been shown by conformance assessment to be non conforming to the referenced base specification.

Strike the appropriate words in this sentence. If the PICS for this IUT is consistent with the static conformance requirements (as specified in clause 3 in this report) and there are no "FAIL" verdicts to be recorded (in clause 6) strike the words "has or" otherwise strike the words "or has not".

B.3 Static conformance summary

The PICS for this IUT is/is not consistent with the static conformance requirements in the specified protocol.

Strike the appropriate words in this sentence.

B.4 Dynamic conformance summary

The test campaign did/did not reveal errors in the IUT.

Strike the appropriate words in this sentence. If there are no "FAIL" verdicts to be recorded (in clause 6 of this report) strike the words "did/" otherwise strike the words "did not".

B.5 Static conformance review report

If clause 3 indicates non-conformance, this subclause itemizes the mismatches between the PICS and the static conformance requirements of the specified protocol specification.

.....

.....

.....

.....

B.6 Test campaign report

ATS Reference	Selected?	Run?	Verdict	Observations (Reference to any observations made in clause 7)
TC002AA	Yes/No	Yes/No		
TC002AE	Yes/No	Yes/No		
TC002AG	Yes/No	Yes/No		
TC002AI	Yes/No	Yes/No		
TC002AJ	Yes/No	Yes/No		
TC002AL	Yes/No	Yes/No		
TC002AM	Yes/No	Yes/No		
TC002AZ	Yes/No	Yes/No		
TC002BA	Yes/No	Yes/No		
TC002BB	Yes/No	Yes/No		
TC002BC	Yes/No	Yes/No		
TC002BD	Yes/No	Yes/No		
TC002BE	Yes/No	Yes/No		
TC002BF	Yes/No	Yes/No		
TC002BG	Yes/No	Yes/No		
TC002BH	Yes/No	Yes/No		
TC002BI	Yes/No	Yes/No		
TC002BJ	Yes/No	Yes/No		
TC002BK	Yes/No	Yes/No		
TC002BL	Yes/No	Yes/No		
TC002BN	Yes/No	Yes/No		
TC002BO	Yes/No	Yes/No		
TC002BQ	Yes/No	Yes/No		
TC002BS	Yes/No	Yes/No		
TC002BT	Yes/No	Yes/No		
TC002BU	Yes/No	Yes/No		
TC002BV	Yes/No	Yes/No		
TC002BW	Yes/No	Yes/No		
TC002BX	Yes/No	Yes/No		
TC002BY	Yes/No	Yes/No		
TC002BZ	Yes/No	Yes/No		
TC002CA	Yes/No	Yes/No		
TC002CB	Yes/No	Yes/No		
TC002CC	Yes/No	Yes/No		
TC002CD	Yes/No	Yes/No		
TC002CE	Yes/No	Yes/No		
TC002JD	Yes/No	Yes/No		
TC002JE	Yes/No	Yes/No		
TC002JF	Yes/No	Yes/No		
TC002JG	Yes/No	Yes/No		
TC002JH	Yes/No	Yes/No		
TC002JI	Yes/No	Yes/No		
TC002JK	Yes/No	Yes/No		
TC002JL	Yes/No	Yes/No		
TC002JM	Yes/No	Yes/No		
TC002JO	Yes/No	Yes/No		
TC002JP	Yes/No	Yes/No		
TC002JR	Yes/No	Yes/No		
TC002JS	Yes/No	Yes/No		
TC002JU	Yes/No	Yes/No		
TC002JV	Yes/No	Yes/No		
TC002JW	Yes/No	Yes/No		
TC002JX	Yes/No	Yes/No		
TC002JY	Yes/No	Yes/No		
TC002JZ	Yes/No	Yes/No		
TC002KA	Yes/No	Yes/No		
TC002KB	Yes/No	Yes/No		
TC002KC	Yes/No	Yes/No		

ATS Reference	Selected?	Run?	Verdict	Observations (Reference to any observations made in clause 7)
TC002KM	Yes/No	Yes/No		
TC002KN	Yes/No	Yes/No		
TC002KP	Yes/No	Yes/No		
TC002KQ	Yes/No	Yes/No		
TC002KR	Yes/No	Yes/No		
TC002KS	Yes/No	Yes/No		
TC002KT	Yes/No	Yes/No		
TC002XA	Yes/No	Yes/No		
TC002XB	Yes/No	Yes/No		
TC002XC	Yes/No	Yes/No		
TC002XD	Yes/No	Yes/No		
TC002XE	Yes/No	Yes/No		
TC002XF	Yes/No	Yes/No		
TC002XG	Yes/No	Yes/No		
TC002YG	Yes/No	Yes/No		
TC002YJ	Yes/No	Yes/No		
TC002YK	Yes/No	Yes/No		
TC002YL	Yes/No	Yes/No		
TC002YM	Yes/No	Yes/No		
TC002YN	Yes/No	Yes/No		
TC002YO	Yes/No	Yes/No		
TC002YP	Yes/No	Yes/No		
TC003YQ	Yes/No	Yes/No		
TC002YR	Yes/No	Yes/No		
TC002YS	Yes/No	Yes/No		
TC002YT	Yes/No	Yes/No		
TC002YU	Yes/No	Yes/No		
TC002YV	Yes/No	Yes/No		
TC002YW	Yes/No	Yes/No		
TC002YX	Yes/No	Yes/No		
TC002YY	Yes/No	Yes/No		
TC002YZ	Yes/No	Yes/No		
TC002ZA	Yes/No	Yes/No		
TC002ZB	Yes/No	Yes/No		
TC002ZD	Yes/No	Yes/No		
TC002ZE	Yes/No	Yes/No		
TC002ZF	Yes/No	Yes/No		
TC002ZG	Yes/No	Yes/No		
TC003AV	Yes/No	Yes/No		
TC003AW	Yes/No	Yes/No		
TC003FP	Yes/No	Yes/No		
TC003FQ	Yes/No	Yes/No		
TC003FR	Yes/No	Yes/No		
TC003FS	Yes/No	Yes/No		
TC003FT	Yes/No	Yes/No		
TC003FU	Yes/No	Yes/No		
TC003FX	Yes/No	Yes/No		
TC003GD	Yes/No	Yes/No		
TC003GE	Yes/No	Yes/No		
TC003GL	Yes/No	Yes/No		
TC003GM	Yes/No	Yes/No		
TC003GO	Yes/No	Yes/No		
TC003GQ	Yes/No	Yes/No		
TC003GS	Yes/No	Yes/No		
TC003GZ	Yes/No	Yes/No		
TC003HB	Yes/No	Yes/No		
TC003HE	Yes/No	Yes/No		
TC003HF	Yes/No	Yes/No		
TC003HT	Yes/No	Yes/No		
TC003HU	Yes/No	Yes/No		
TC003HV	Yes/No	Yes/No		
TC003HW	Yes/No	Yes/No		

ATS Reference	Selected?	Run?	Verdict	Observations (Reference to any observations made in clause 7)
TC003XX	Yes/No	Yes/No		
TC003ZC	Yes/No	Yes/No		
TC004AX	Yes/No	Yes/No		
TC004AY	Yes/No	Yes/No		
TC004GA	Yes/No	Yes/No		
TC004GB	Yes/No	Yes/No		
TC004GF	Yes/No	Yes/No		
TC004GG	Yes/No	Yes/No		
TC004HX	Yes/No	Yes/No		
TC004HY	Yes/No	Yes/No		
TC004IA	Yes/No	Yes/No		
TC004IB	Yes/No	Yes/No		
TC004IC	Yes/No	Yes/No		
TC004YA	Yes/No	Yes/No		
TC004YB	Yes/No	Yes/No		
TC004YC	Yes/No	Yes/No		
TC012CF	Yes/No	Yes/No		
TC012CG	Yes/No	Yes/No		
TC012CH	Yes/No	Yes/No		
TC012CI	Yes/No	Yes/No		
TC012CJ	Yes/No	Yes/No		
TC012CK	Yes/No	Yes/No		
TC012CL	Yes/No	Yes/No		
TC012CM	Yes/No	Yes/No		
TC012CN	Yes/No	Yes/No		
TC012CO	Yes/No	Yes/No		
TC012CP	Yes/No	Yes/No		
TC012CQ	Yes/No	Yes/No		
TC012CR	Yes/No	Yes/No		
TC012CS	Yes/No	Yes/No		
TC012CU	Yes/No	Yes/No		
TC012CV	Yes/No	Yes/No		
TC012CW	Yes/No	Yes/No		
TC012CX	Yes/No	Yes/No		
TC012CY	Yes/No	Yes/No		
TC012CZ	Yes/No	Yes/No		
TC012DI	Yes/No	Yes/No		
TC012DJ	Yes/No	Yes/No		
TC012DK	Yes/No	Yes/No		
TC012XL	Yes/No	Yes/No		
TC012XM	Yes/No	Yes/No		
TC012XN	Yes/No	Yes/No		
TC013FO	Yes/No	Yes/No		
TC013GP	Yes/No	Yes/No		
TC013GX	Yes/No	Yes/No		
TC013GY	Yes/No	Yes/No		
TC013HC	Yes/No	Yes/No		
TC013HD	Yes/No	Yes/No		
TC013HH	Yes/No	Yes/No		
TC013HI	Yes/No	Yes/No		
TC013HJ	Yes/No	Yes/No		
TC013HK	Yes/No	Yes/No		
TC013HL	Yes/No	Yes/No		
TC013HM	Yes/No	Yes/No		
TC013HN	Yes/No	Yes/No		
TC013HO	Yes/No	Yes/No		
TC013HP	Yes/No	Yes/No		
TC013HQ	Yes/No	Yes/No		
TC013HR	Yes/No	Yes/No		
TC013HS	Yes/No	Yes/No		
TC013XO	Yes/No	Yes/No		
TC013XP	Yes/No	Yes/No		

ATS Reference	Selected?	Run?	Verdict	Observations (Reference to any observations made in clause 7)
TC013XQ	Yes/No	Yes/No		
TC013XR	Yes/No	Yes/No		
TC014FV	Yes/No	Yes/No		
TC014FW	Yes/No	Yes/No		
TC014FY	Yes/No	Yes/No		
TC014FZ	Yes/No	Yes/No		
TC014GH	Yes/No	Yes/No		
TC014GI	Yes/No	Yes/No		
TC014GJ	Yes/No	Yes/No		
TC014GK	Yes/No	Yes/No		
TC014GT	Yes/No	Yes/No		
TC014GU	Yes/No	Yes/No		
TC014GV	Yes/No	Yes/No		
TC014GW	Yes/No	Yes/No		
TC014XS	Yes/No	Yes/No		
TC014XT	Yes/No	Yes/No		
TC022EL	Yes/No	Yes/No		
TC022EM	Yes/No	Yes/No		
TC022EN	Yes/No	Yes/No		
TC022EO	Yes/No	Yes/No		
TC022EP	Yes/No	Yes/No		
TC022EQ	Yes/No	Yes/No		
TC022ER	Yes/No	Yes/No		
TC022ES	Yes/No	Yes/No		
TC022ET	Yes/No	Yes/No		
TC022EU	Yes/No	Yes/No		
TC022FM	Yes/No	Yes/No		
TC022FN	Yes/No	Yes/No		
TC022YE	Yes/No	Yes/No		
TC023EV	Yes/No	Yes/No		
TC023EX	Yes/No	Yes/No		
TC023EY	Yes/No	Yes/No		
TC023FG	Yes/No	Yes/No		
TC023FH	Yes/No	Yes/No		
TC023FI	Yes/No	Yes/No		
TC023FJ	Yes/No	Yes/No		
TC023FK	Yes/No	Yes/No		
TC023FL	Yes/No	Yes/No		
TC023YF	Yes/No	Yes/No		
TC024EW	Yes/No	Yes/No		
TC024EZ	Yes/No	Yes/No		
TC024FA	Yes/No	Yes/No		
TC024FB	Yes/No	Yes/No		
TC024FC	Yes/No	Yes/No		
TC024FD	Yes/No	Yes/No		
TC024FE	Yes/No	Yes/No		
TC024FF	Yes/No	Yes/No		
TC032EB	Yes/No	Yes/No		
TC032EC	Yes/No	Yes/No		
TC032ED	Yes/No	Yes/No		
TC032EF	Yes/No	Yes/No		
TC032EG	Yes/No	Yes/No		
TC032EH	Yes/No	Yes/No		
TC032EI	Yes/No	Yes/No		
TC032EK	Yes/No	Yes/No		
TC032SA	Yes/No	Yes/No		
TC032SB	Yes/No	Yes/No		
TC032SC	Yes/No	Yes/No		
TC032SD	Yes/No	Yes/No		
TC032SE	Yes/No	Yes/No		
TC032SF	Yes/No	Yes/No		
TC032SG	Yes/No	Yes/No		

ATS Reference	Selected?	Run?	Verdict	Observations (Reference to any observations made in clause 7)
TC032SH	Yes/No	Yes/No		
TC032SI	Yes/No	Yes/No		
TC032SJ	Yes/No	Yes/No		
TC032SK	Yes/No	Yes/No		
TC032SL	Yes/No	Yes/No		
TC032SM	Yes/No	Yes/No		
TC032SN	Yes/No	Yes/No		
TC032SO	Yes/No	Yes/No		
TC032SP	Yes/No	Yes/No		
TC032SQ	Yes/No	Yes/No		
TC032SR	Yes/No	Yes/No		
TC032SS	Yes/No	Yes/No		
TC032ST	Yes/No	Yes/No		
TC032SU	Yes/No	Yes/No		
TC032SV	Yes/No	Yes/No		
TC032SX	Yes/No	Yes/No		
TC032SY	Yes/No	Yes/No		
TC032SZ	Yes/No	Yes/No		
TC032WA	Yes/No	Yes/No		
TC032WB	Yes/No	Yes/No		
TC032WC	Yes/No	Yes/No		
TC033IG	Yes/No	Yes/No		
TC042TA	Yes/No	Yes/No		
TC042ZH	Yes/No	Yes/No		
TC042ZI	Yes/No	Yes/No		
TC042TB	Yes/No	Yes/No		
TC042TC	Yes/No	Yes/No		
TC042TD	Yes/No	Yes/No		
TC042TE	Yes/No	Yes/No		
TC042TF	Yes/No	Yes/No		
TC042TG	Yes/No	Yes/No		
TC042TH	Yes/No	Yes/No		
TC042TI	Yes/No	Yes/No		
TC042TJ	Yes/No	Yes/No		
TC042TK	Yes/No	Yes/No		
TC042TL	Yes/No	Yes/No		
TC042YH	Yes/No	Yes/No		
TC042YI	Yes/No	Yes/No		
TC042ZJ	Yes/No	Yes/No		
TC043GN	Yes/No	Yes/No		
TC043HA	Yes/No	Yes/No		
TC043YD	Yes/No	Yes/No		
TC044GC	Yes/No	Yes/No		
TC102AN	Yes/No	Yes/No		
TC102AO	Yes/No	Yes/No		
TC102AP	Yes/No	Yes/No		
TC102AQ	Yes/No	Yes/No		
TC102AR	Yes/No	Yes/No		
TC102AS	Yes/No	Yes/No		
TC102AT	Yes/No	Yes/No		
TC102AU	Yes/No	Yes/No		
TC202JB	Yes/No	Yes/No		
TC202JC	Yes/No	Yes/No		
TC202JT	Yes/No	Yes/No		
TC202KE	Yes/No	Yes/No		
TC202KG	Yes/No	Yes/No		
TC202KH	Yes/No	Yes/No		
TC202KI	Yes/No	Yes/No		
TC202KJ	Yes/No	Yes/No		
TC202KK	Yes/No	Yes/No		
TC202KL	Yes/No	Yes/No		
TC202XJ	Yes/No	Yes/No		

ATS Reference	Selected?	Run?	Verdict	Observations (Reference to any observations made in clause 7)
TC202XK	Yes/No	Yes/No		
TC212KU	Yes/No	Yes/No		
TC212KW	Yes/No	Yes/No		
TC212KX	Yes/No	Yes/No		
TC302LA	Yes/No	Yes/No		
TC302LB	Yes/No	Yes/No		
TC302LC	Yes/No	Yes/No		
TC302LD	Yes/No	Yes/No		
TC302LE	Yes/No	Yes/No		
TC302LF	Yes/No	Yes/No		
TC302LG	Yes/No	Yes/No		
TC302LH	Yes/No	Yes/No		
TC302LI	Yes/No	Yes/No		
TC302LJ	Yes/No	Yes/No		
TC302LK	Yes/No	Yes/No		
TC302LL	Yes/No	Yes/No		
TC302LM	Yes/No	Yes/No		
TC302LN	Yes/No	Yes/No		
TC302LP	Yes/No	Yes/No		
TC302LQ	Yes/No	Yes/No		
TC302LR	Yes/No	Yes/No		
TC302LS	Yes/No	Yes/No		
TC302LT	Yes/No	Yes/No		
TC302LU	Yes/No	Yes/No		
TC302LV	Yes/No	Yes/No		
TC302LW	Yes/No	Yes/No		
TC302LX	Yes/No	Yes/No		
TC302LY	Yes/No	Yes/No		
TC302LZ	Yes/No	Yes/No		
TC302MA	Yes/No	Yes/No		
TC302MB	Yes/No	Yes/No		
TC302MC	Yes/No	Yes/No		
TC302MD	Yes/No	Yes/No		
TC302ME	Yes/No	Yes/No		
TC302MF	Yes/No	Yes/No		
TC302MG	Yes/No	Yes/No		
TC302MH	Yes/No	Yes/No		
TC302MJ	Yes/No	Yes/No		
TC302ML	Yes/No	Yes/No		
TC302OM	Yes/No	Yes/No		
TC302ON	Yes/No	Yes/No		
TC302OO	Yes/No	Yes/No		
TC302OP	Yes/No	Yes/No		
TC302OS	Yes/No	Yes/No		
TC302OU	Yes/No	Yes/No		
TC302OV	Yes/No	Yes/No		
TC302OW	Yes/No	Yes/No		
TC302OX	Yes/No	Yes/No		
TC302OY	Yes/No	Yes/No		
TC302OZ	Yes/No	Yes/No		
TC302PA	Yes/No	Yes/No		
TC302PB	Yes/No	Yes/No		
TC302PC	Yes/No	Yes/No		
TC302PD	Yes/No	Yes/No		
TC302PE	Yes/No	Yes/No		
TC302PF	Yes/No	Yes/No		
TC302PG	Yes/No	Yes/No		
TC302PH	Yes/No	Yes/No		
TC302PI	Yes/No	Yes/No		
TC302PJ	Yes/No	Yes/No		
TC302PK	Yes/No	Yes/No		
TC302PL	Yes/No	Yes/No		

ATS Reference	Selected?	Run?	Verdict	Observations (Reference to any observations made in clause 7)
TC302PM	Yes/No	Yes/No		
TC302PS	Yes/No	Yes/No		
TC302PT	Yes/No	Yes/No		
TC302PU	Yes/No	Yes/No		
TC302PV	Yes/No	Yes/No		
TC302PW	Yes/No	Yes/No		
TC302QI	Yes/No	Yes/No		
TC302QJ	Yes/No	Yes/No		
TC302QK	Yes/No	Yes/No		
TC302QL	Yes/No	Yes/No		
TC302RL	Yes/No	Yes/No		
TC302RM	Yes/No	Yes/No		
TC312NB	Yes/No	Yes/No		
TC312NC	Yes/No	Yes/No		
TC312ND	Yes/No	Yes/No		
TC312NE	Yes/No	Yes/No		
TC312NF	Yes/No	Yes/No		
TC312NG	Yes/No	Yes/No		
TC312NH	Yes/No	Yes/No		
TC312NI	Yes/No	Yes/No		
TC312NJ	Yes/No	Yes/No		
TC312NK	Yes/No	Yes/No		
TC312NL	Yes/No	Yes/No		
TC312NM	Yes/No	Yes/No		
TC312NN	Yes/No	Yes/No		
TC312NO	Yes/No	Yes/No		
TC312NP	Yes/No	Yes/No		
TC312NQ	Yes/No	Yes/No		
TC312NR	Yes/No	Yes/No		
TC312NS	Yes/No	Yes/No		
TC312NV	Yes/No	Yes/No		
TC312NW	Yes/No	Yes/No		
TC312NX	Yes/No	Yes/No		
TC312NY	Yes/No	Yes/No		
TC312NZ	Yes/No	Yes/No		
TC312OA	Yes/No	Yes/No		
TC312OC	Yes/No	Yes/No		
TC312PY	Yes/No	Yes/No		
TC312PZ	Yes/No	Yes/No		
TC312QA	Yes/No	Yes/No		
TC312QB	Yes/No	Yes/No		
TC312QC	Yes/No	Yes/No		
TC312QD	Yes/No	Yes/No		
TC312QE	Yes/No	Yes/No		
TC312ZK	Yes/No	Yes/No		
TC402EA	Yes/No	Yes/No		
TC402VA	Yes/No	Yes/No		
TC402VB	Yes/No	Yes/No		
TC402VC	Yes/No	Yes/No		
TC402VD	Yes/No	Yes/No		
TC502UA	Yes/No	Yes/No		
TC502UB	Yes/No	Yes/No		
TC502UC	Yes/No	Yes/No		
TC502UD	Yes/No	Yes/No		
TC502UE	Yes/No	Yes/No		
TC502UF	Yes/No	Yes/No		
TC502UG	Yes/No	Yes/No		
TC502UH	Yes/No	Yes/No		
TC502UI	Yes/No	Yes/No		
TC502UJ	Yes/No	Yes/No		

B.7 Observations

Additional information relevant to the technical content of the PCTR are given here.

Annex C (normative): Abstract Test Suite (ATS) for PSS1_BC

This ATS has been produced using the Tree and Tabular Combined Notation (TTCN) according to ISO/IEC 9646-3 [9].

The ATS was developed on a separate TTCN software tool and therefore the TTCN tables are not completely referenced in the table of contents. The ATS itself contains a test suite overview part which provides additional information and references.

C.1 The TTCN Graphical form (TTCN.GR)

The TTCN.GR representation of this ATS is contained in an Adobe Portable Document Format™ file (QSIG_BC04.PDF contained in archive en_30080502v010201v0.ZIP) which accompanies the present document.

C.2 The TTCN Machine Processable form (TTCN.MP)

The TTCN.MP representation corresponding to this ATS is contained in an ASCII file (QSIG_BC04.MP contained in archive en_30080502v010201v0.ZIP) which accompanies the present document.

Annex D (informative): Compatibility

D.1 Other PSS1 protocol specifications

This ATS specification can be used to test implementations implemented according to certain other PSS1 base specifications. The standards and editions supported are indicated in table D.1. Where an edition is shown as being partially supported this means that no special provision has been made for support of that edition and a small number of test cases are unsuitable.

Table D.1: Protocol specifications supported

Standard	Editions Supported	Editions Partially supported	Editions Not supported
EN 300 172 [3]	V1.4.1 Edition 3		Edition 1 Edition 2
ISO/IEC 11572 [12]	Edition2 with Amd.1 and Amd.2	Edition 2 (unamended) Edition 1	
ECMA-143 [1]	Edition3		Edition 1 Edition 2
EN 301 048 [6]	V1.1.1		
ISO/IEC 15056 [13]	Edition 1		
ECMA-225 [2]	Edition 2		

When testing implementations according to these standards the test suite parameters corresponding to PICS items should be set according to tables D.2 and D.3 below.

NOTE 1: Where another version is stricter than EN 300 172 [3] this ATS does not test to the stricter requirements.

NOTE 2: There are minor differences in the coding of certain information elements between the different protocol specifications. In these cases coding valid according to any of the standards supported is accepted by the ATS.

NOTE 3: Where "TRUE" or "FALSE" is indicated in tables D.2 and D.3 these values should be used for the test suite parameters to ensure correct test case selection. In a few cases this may not reflect whether the feature is actually implemented.

Table D.2: PICS parameters for Basic Call

Test suite parameter	Description	EN 300 172 V1.4.1 or ECMA-143 Edition 3	ETS 300 172 Edition 3	ISO/IEC 11572 Edition 2 including Amd.1 and Amd.2	ISO/IEC 11572 Edition 1
PC_A14	STATUS ENQUIRY	A14	A14	A14	A14
PC_B1	Originating	B1	B1	B1	B1
PC_B2	Incoming Gateway	B2	B2	B2	B2
PC_B3	Transit	B3	B3	B3	B3
PC_B4	Terminating	B4	B4	B4	B4
PC_B5	Outgoing Gateway	B5	B5	B5	B5
PC_B7	Sending Complete always used	B7	B7	B7	B7
PC_B9_N	Overlap receiving to be tested	B9 (note 1)	B9 (note 1)	B9 (note 1)	B9 (note 1)
PC_B10	Overlap sending	B10	B10	B10	B10
PC_B16_N	CONN ACK not sent	B16 (note 2)	B16 (note 2)	B16 (note 2)	B16 (note 2)
PC_C2	Call abort supported (transit)	C2	C2	C2	C2
PC_H1	All channels RESTART	H1	H1	H1	H1
PC_H2	Multiple channel RESTART	H2	FALSE	H2	FALSE
PC_H3	Single channel RESTART	H3	H2	H3	H2
PC_I1	T301 supported	I1	I1	I1	I1
PC_I1_VAL	T301 duration	I1	I1	I1	I1
PC_I8	T310 supported	I8	I8	I8	I8
PC_I8_VAL	T310 duration	I8	I8	I8	I8
PC_I9	T313 supported	I9	I9	I9	I9
PC_K5	Segmentation supported	K5	K5	K5 (note 1)	FALSE
PC_K6	Re-assembly supported	K6	K6	K6 (note 1)	FALSE
PC_N1	Party category	N1	N1	FALSE	FALSE
PC_N7	Party category in SETUP	N7	N7	FALSE	FALSE
PC_N9	Party category in CONNECT	N9	N9	FALSE	FALSE
PC_Z1	Unrestricted digital	Z1	Z1	Z1	Z1
PC_Z2	Speech	Z2	Z2	Z2	Z2
PC_Z3	3.1 kHz Audio	Z3	Z3	Z3	Z3
PC_Z4	Multirate	Z4	FALSE	Z4	FALSE
PC_Z5	A-law	Z5	TRUE	Z5	TRUE
PC_Z6	μ -law	Z6	TRUE	Z6	TRUE
PC_Z7	Unrestricted digital with Tones and announcements	Z7 (note 2)	Z4	FALSE	FALSE
-	Additional Progress descriptions	M1, M2	M1,M2	M1,M2 (note 3)	note 3

(note 1) and (note 2) are references to notes in the PICS.

NOTE 1: These items were added to the PICS for ISO/IEC 11572 [12] Edition 2 by Amd.1. If this IUT is implemented according to ISO/IEC 11572 [12] Edition 2 without amendments PC_K5 and PC_K6 should be False.

NOTE 2: In the delta for EN 300 172 [3] V1.4.1 this item has the identifier Z5.

NOTE 3: Additional Progress Descriptions are included in all ETSI and ECMA versions and were added to ISO/IEC 11572 [12] by Amd.2 to edition2. Support of them is mandatory in all versions in which they are included. If the IUT is implemented according to ISO/IEC 11572 [12] edition 1 or edition 2 without amendments then TC002ZD, TC002ZE, TC002ZF and TC002ZG can give Fail verdicts as a result of this not being implemented.

Table D.3: PICS Parameters for ANF-TC

Test suite parameter	Description	EN 301 048 V1.1.1, ISO/IEC 15056 or ECMA-225 Edition 2	ETS 300 172 Edition 3	ANF-TC not implemented
PC_TC_A1	Originating ANF-TC for Basic Call	A1	L2	FALSE
PC_TC_A3	Terminating ANF-TC for Basic Call	A2	L5	FALSE
PC_TC_A5	Transit ANF-TC for Basic Call	A3	L4	FALSE
PC_TC_A7	Incoming Gateway ANF-TC for Basic Call	A4	L3	FALSE

D.2 Other connection scenarios

D.2.1 Number of channels

As the scope of the present document refers to scenarios involving connection over a Basic access or Primary rate access, it has been assumed that the number of information channels does not exceed 30. If a larger number of information channels are implemented then certain test cases cannot be used without modification depending on the number of channels supported.

In a number of places in the ATS it is assumed that a channel number can be coded in one octet, this provides an effective limitation to 127 channels unless significant modifications are made to overcome this constraint.

A small number of test cases concerning multirate call collisions (e.g. TC002YW) can give an inconclusive verdict if the number of free channels after the IUT has sent a SETUP is too large. If the number of information channels is in the range 32 to 59 these TCs are useable if the IUT requests sufficient channels in the SETUP messages it sends. If the number of information channels is 60 or greater they cannot be used.

D.2.2 Coding of information elements

In the standards specifying certain interconnection scenarios additional codepoints are defined. In order to test an implementation for such a scenario it would be necessary to modify certain constraints to include the additional codepoints.

Annex E (informative): Summary of changes from previous edition

E.1 Introduction

This annex contains a summary of the changes made to the ATS since ETS 300 805-2. It is not comprehensive and is intended to be of assistance to users of the present document, in particular test suite implementers, identifying what changes are significant. Changes directly resulting from new, modified or deleted test purposes are not identified here.

E.2 Test Suite Structure and Test Case identifier changes

The Test Suite Structure has been simplified and corresponding changes made in the TC identifiers. The normal mapping between old and new identifiers is:

- the first digit (Protocol Control or Call Control role) is the same as the first digit in edition 1;
- the second digit (phase of protocol) is the same as the fourth digit in edition 1;
- the third digit (nature of the test) is the same as the second digit in edition 1 where that was 2, 3 or 4 and 2 where it was 0 or 1;
- the two letters uniquely identifying the TP are the same as in edition 1.

The mapping of identifiers which do not follow the normal rules is indicated in table E.1.

Table E.1

Old identifier	New identifier
TC0113IG	TC033IG
TC0311FX	TC013FX
TC0311HB	TC003HB
TC0311GT	TC014GT
TC0311GU	TC014GU
TC0311GV	TC014GV
TC0311GW	TC014GW

E.3 Support for multirate

In a large number of places in the ATS changes have been made to support the use of the multirate bearer by the IUT. In test cases where the IUT sends a SETUP multirate is generally accepted except where the test purpose precludes this, where the tester sends a SETUP this is not multirate unless explicitly required by the test purpose. General changes relating to this include storing the whole Channel ID IE from received SETUP messages (instead of only the channel number) and changes to the Bearer capability field in constraints for received SETUPS. There are also changes to preambles used for some test cases.

E.4 Test Suite Operation and type changes

Most of TSOs have been converted to the procedural operation without changing their functionality. These are mainly to take advantage of the procedural notation in TTCN V2 and thereby reduce the number of test suite operations described in free text.

The types used to hold raw received or re-assembled segmented messages and IEs extracted by `find_ie` have been changed to BITSTRING from PDU, Q931MSG and OCTETSTRING respectively. For this reason, the types of parameters and results of several TSOs have been changed without any functional change.

Functional changes has been made in the following TSOs:

- "**add_chnum_to_list**" and "**extr_chi_num**" to handle multirate;
- "**add_pi_to_list**" and "**check_pi_og**" for corrections.

A lot of procedural test suite operation have been added to handle Channel ID (to support multirate) and for string operations.

It was not practical to completely define the string operations in the procedural notation. Therefore three of them ("**octetstring_to_bitstring**", "**bitstring_to_octetstring**" and "**set_bits**") are defined in free text, and the others make use of them. This is to minimize the number of free text operations and is not intended to constrain implementations.

E.5 Review of derivation of TPs

There are some cases in previous edition where two or more test purposes (TPs) are derived from a single Super Test Purpose (STP) where this seems unnecessary. In all these cases the precondition and stimulus is the same, the TPs differ in which aspects of the IUTs response is checked. A small reduction in the size of the test suite was made by retaining only one derived TP (and hence one TC) for each of these STPs testing all the aspects.

Tests concerned (edition 1 → edition 2):

- check of different mandatory IEs:
 - SP007: TC0100AA, TC0110AB, TC0110AC, TC0110AD → TC002AA;
 - SP040: TC0100BO, TC0510BP → TC002BO.
- state check and coding check:
 - SP008: TC0100AE, TC0510AF → TC002AE;
 - SP009: TC0500AG, TC0510AH → TC002AC;
 - SP025: TC0100JI, TC0510JJ → TC002JI;
 - SP029: TC0100BH, TC0510BI → TC002BH;
 - SP047: TC0100KC, TC0510KD → TC002KC;
 - SP068: TC0201DK, TC0211DL → TC012DK.
- different aspects of coding:
 - SP011: TC0010AJ, TC0010AK (CR flag and CR length) → TC002AJ.

E.6 Test suite parameters and test case selection

There have been a number of change to the test case selection and use of test suite parameters. This is to take into account the new PICS proformas, improve consistency with the PIXIT proforma, correct errors and remove redundant test suite parameters.

Bibliography

The following material, though not specifically referenced in the body of the present document (or not publicly available), gives supporting information.

- ETS 300 406: "Methods for Testing and Specification (MTS); Protocol and profile conformance testing specifications; Standardization methodology".

History

Document history		
Edition 1	February 1998	Publication as ETS 300 805-2
V1.2.1	August 1999	Public Enquiry PE 9955: 1999-08-18 to 1999-12-17
V1.2.1	February 2000	Vote V 200017: 2000-02-28 to 2000-04-28