

# EN 300 789 V1.1.1 (1998-03)

---

*European Standard (Telecommunications series)*

**Electromagnetic compatibility  
and Radio spectrum Matters (ERM);  
Terrestrial Flight Telecommunications System (TFTS);  
Avionic termination radio testing specification**

---



*European Telecommunications Standards Institute*

---

---

**Reference**

DEN/ERM-RP05-01/4 (7b000ico.PDF)

---

**Keywords**

Radio, testing, TFTS

***ETSI Secretariat***

---

**Postal address**

F-06921 Sophia Antipolis Cedex - FRANCE

---

**Office address**

650 Route des Lucioles - Sophia Antipolis  
Valbonne - FRANCE  
Tel.: +33 4 92 94 42 00 Fax: +33 4 93 65 47 16  
Siret N° 348 623 562 00017 - NAF 742 C  
Association à but non lucratif enregistrée à la  
Sous-Préfecture de Grasse (06) N° 7803/88

---

**Internet**

secretariat@etsi.fr  
<http://www.etsi.fr>  
<http://www.etsi.org>

---

***Copyright Notification***

No part may be reproduced except as authorized by written permission.  
The copyright and the foregoing restriction extend to reproduction in all media.

# Contents

|   |    |
|---|----|
| Intellectual Property Rights.....                                 | 5  |
| Foreword .....  | 5  |
| 1 Scope.....  | 6  |
| 2 Normative references .....                                      | 6  |
| 3 Definitions, abbreviations and symbols.....                     | 6  |
| 3.1 Definitions .....   | 6  |
| 3.2 Abbreviations.....  | 7  |
| 3.3 Symbols .....   | 7  |
| 4 Frequency range and radio channel arrangement .....             | 7  |
| 4.1 Frequency range.....  | 7  |
| 4.2 Radio channel arrangement.....                                | 7  |
| 4.3 Modulation.....   | 8  |
| 5 General aspects of TFTS testing procedures .....                | 9  |
| 5.1 Protection of the TFTS network .....                          | 9  |
| 5.2 Protection of other services.....                             | 9  |
| 5.3 Access to signals.....  | 9  |
| 5.4 Environmental conditions for tests.....                       | 9  |
| 5.5 Power supply requirements .....                               | 9  |
| 6 Tests of radio aspects of the physical layer .....              | 10 |
| 6.1 General.....  | 10 |
| 6.1.1 Documentation .....   | 10 |
| 6.1.2 Limits for radio measurements for conformance testing ..... | 10 |
| 6.1.2.1 Unwanted emissions .....                                  | 10 |
| 6.1.2.2 Modulator and transmitter accuracy .....                  | 10 |
| 6.1.2.3 Frequency error .....                                     | 10 |
| 6.1.2.4 Transmitter output power .....                            | 10 |
| 6.1.2.5 RF spectrum.....  | 10 |
| 6.1.2.6 Receiver sensitivity without interferer.....              | 10 |
| 6.1.2.7 Co-channel sensitivity.....                               | 10 |
| 6.1.2.8 Adjacent channel sensitivity .....                        | 11 |
| 6.1.3 Test apparatus .....  | 11 |
| 6.1.4 AT testing facilities .....                                 | 11 |
| 6.1.4.1 Direct control of AT .....                                | 11 |
| 6.1.4.2 Loopback facility.....                                    | 11 |
| 6.1.4.3 Continuous modulation mode.....                           | 12 |
| 6.1.4.3.1 Test signals .....                                      | 12 |
| 6.1.4.4 Suppressed modulation mode.....                           | 12 |
| 6.1.4.5 Standby mode .....  | 12 |
| 6.1.5 Mean to peak ratio of $\pi/4$ DQPSK modulation .....        | 12 |
| 6.1.6 Uncertainty in measurements .....                           | 13 |
| 6.1.7 Measurements made under continuous or burst modulation..... | 13 |
| 6.1.8 EMC.....  | 13 |
| 6.2 Measurement of unwanted emissions.....                        | 13 |
| 6.2.1 General .....   | 13 |
| 6.2.2 Reference documents and specification.....                  | 13 |
| 6.2.2.1 Out of band emissions .....                               | 13 |
| 6.2.2.2 Spurious emissions .....                                  | 13 |
| 6.2.3 Purpose of the tests.....                                   | 14 |
| 6.2.4 Method of measurement.....                                  | 14 |
| 6.2.4.1 Out of band emissions .....                               | 14 |
| 6.2.4.2 Spurious emissions .....                                  | 14 |
| 6.2.5 Test bank characteristics .....                             | 14 |

|         |   |    |
|---------|---|----|
| 6.2.6   | Measurement uncertainty .....                                     | 15 |
| 6.3     | Modulator and transmitter accuracy.....                           | 15 |
| 6.3.1   | General .....   | 15 |
| 6.3.2   | Reference documents and specification.....                        | 15 |
| 6.3.3   | Purpose of the test .....   | 15 |
| 6.3.4   | Method of measurement .....                                       | 16 |
| 6.3.5   | Test bank characteristics .....                                   | 16 |
| 6.3.6   | Measurement uncertainty .....                                     | 16 |
| 6.4     | Frequency error.....  | 16 |
| 6.4.1   | General.....  | 16 |
| 6.4.2   | Reference documents and specification.....                        | 16 |
| 6.4.3   | Purpose of the test .....   | 16 |
| 6.4.4   | Method of measurement.....  | 16 |
| 6.4.5   | Test bank characteristics .....                                   | 17 |
| 6.4.6   | Measurement uncertainty .....                                     | 17 |
| 6.5     | Mean transmitter output power .....                               | 17 |
| 6.5.1   | General.....  | 17 |
| 6.5.2   | Mean transmitter power output under continuous transmission ..... | 17 |
| 6.5.2.1 | Reference documents and specification .....                       | 17 |
| 6.5.2.2 | Purpose of the test .....   | 17 |
| 6.5.2.3 | Method of measurement .....                                       | 18 |
| 6.5.2.4 | Test bank characteristics.....                                    | 18 |
| 6.5.2.5 | Measurement uncertainty.....                                      | 18 |
| 6.6     | RF spectrum mask.....   | 19 |
| 6.6.1   | General.....  | 19 |
| 6.6.2   | Reference documents and specification.....                        | 19 |
| 6.6.3   | Purpose of the test .....   | 19 |
| 6.6.4   | Method of measurement.....  | 19 |
| 6.6.5   | Test bank characteristics .....                                   | 19 |
| 6.6.6   | Measurement uncertainty .....                                     | 20 |
| 6.7     | Receiver sensitivity .....  | 20 |
| 6.7.1   | General.....  | 20 |
| 6.7.2   | Receiver sensitivity with thermal noise .....                     | 20 |
| 6.7.2.1 | Reference documents and specification .....                       | 20 |
| 6.7.2.2 | Purpose of the test .....   | 20 |
| 6.7.2.3 | Method of measurement .....                                       | 20 |
| 6.7.2.4 | Test bank characteristics.....                                    | 21 |
| 6.7.2.5 | Measurement uncertainty.....                                      | 21 |
| 6.7.3   | Receiver sensitivity with in-band intermodulation products.....   | 21 |
| 6.7.3.1 | Reference documents and specification .....                       | 21 |
| 6.7.3.2 | Purpose of the test .....   | 21 |
| 6.7.3.3 | Method of measurement .....                                       | 21 |
| 6.7.3.4 | Test bank characteristics.....                                    | 21 |
| 6.7.3.5 | Measurement uncertainty.....                                      | 22 |
| 6.8     | Co-channel and adjacent channel sensitivity.....                  | 22 |
| 6.8.1   | General.....  | 22 |
| 6.8.2   | Reference document and specification .....                        | 22 |
| 6.8.3   | Purpose of the test .....   | 23 |
| 6.8.4   | Method of measurement.....  | 23 |
| 6.8.5   | Test bank characteristics .....                                   | 23 |
| 6.8.6   | Measurement uncertainty .....                                     | 24 |
|         | History .....   | 25 |

---

## Intellectual Property Rights

IPRs essential or potentially essential to the present document may have been declared to ETSI. The information pertaining to these essential IPRs, if any, is publicly available for **ETSI members and non-members**, and can be found in ETR 314: "*Intellectual Property Rights (IPRs); Essential, or potentially Essential, IPRs notified to ETSI in respect of ETSI standards*", which is available **free of charge** from the ETSI Secretariat. Latest updates are available on the ETSI Web server (<http://www.etsi.fr/ipr>).

Pursuant to the ETSI Interim IPR Policy, no investigation, including IPR searches, has been carried out by ETSI. No guarantee can be given as to the existence of other IPRs not referenced in ETR 314 (or the updates on <http://www.etsi.fr/ipr>) which are, or may be, or may become, essential to the present document.

---

## Foreword

The European Standard (Telecommunications series) has been produced by ETSI Technical Committee Electromagnetic compatibility and Radio spectrum Matters (ERM).

| <b>National transposition dates</b>  |                  |
|--|------------------|
| Date of adoption of this EN:   | 20 February 1998 |
| Date of latest announcement of this EN (doa):  | 30 June 1998     |
| Date of latest publication of new National Standard or endorsement of this EN (dop/e): | 31 December 1998 |
| Date of withdrawal of any conflicting National Standard (dow):                         | 31 December 1998 |

---

# 1 Scope

The present document specifies the measurements to be made to test the radio characteristics of the Avionic Termination (AT) of the Terrestrial Flight Telecommunications System (TFTS), operating in the frequency bands 1 670 MHz to 1 675 MHz (receive) and 1 800 MHz to 1 805 MHz (transmit), and designed according to ETS 300 326 -2 [1]. The present document does not constitute a full Conformance Testing Specification for the TFTS AT.

---

## 2 Normative references

References may be made to:

- a) specific versions of publications (identified by date of publication, edition number, version number, etc.), in which case, subsequent revisions to the referenced document do not apply; or
- b) all versions up to and including the identified version (identified by "up to and including" before the version identity); or
- c) all versions subsequent to and including the identified version (identified by "onwards" following the version identity); or
- d) publications without mention of a specific version, in which case the latest version applies.

A non-specific reference to an ETS shall also be taken to refer to later versions published as an EN with the same number.

- [1] ETS 300 326-2 (1996): "Radio Equipment and Systems (RES); Terrestrial Flight Telephone System (TFTS); Part 2: Speech services, radio interface".
- [2] ETR 028: "Radio Equipment and Systems (RES); Uncertainties in the measurement of mobile radio equipment characteristics".
- [3] The Radio Regulations of the International Telecommunications Union (1993).
- [4] ARINC characteristic 752 (January 1993): "Terrestrial Flight Telephone System (TFTS) Airborne Radio Subsystem".
- [5] EUROCAE ED-14C: "Environmental Conditions and Test Procedures for Airborne Equipment".

---

## 3 Definitions, abbreviations and symbols

### 3.1 Definitions

For the purposes of the present document, the following definitions apply:

**out-of-band emission:** Emission on a frequency or frequencies immediately outside the necessary bandwidth which results from the modulation process, but excluding spurious emissions.

**spurious emission:** Emission on a frequency or frequencies which are outside the necessary bandwidth and the level of which may be reduced without affecting the corresponding transmission of information. Spurious emissions include harmonic emissions, parasitic emissions, intermodulation products and frequency conversion products, but exclude out-of-band emissions.

**unwanted emissions:** Consist of spurious emissions and out-of-band emissions.

**necessary bandwidth:** For a given class of emission, the width of the frequency band which is just sufficient to ensure the transmission of information at the rate and with the quality required under specified conditions.

**occupied bandwidth:** The width of a frequency band such that, below the lower and above the upper frequency limits, the mean powers emitted are each equal to a specified percentage  $P/2$  of the total mean power of a given emission.

**95% confidence level:** 1,96 times the total standard deviation. Based on Student's t factor.

**continuous modulation mode:** See subclause 6.1.4.3.

**suppressed modulation mode:** See subclause 6.1.4.4.

**burst mode:** Transmission with one or more of the four voice channels switched off.

**antenna port:** The end of the duplexer to antenna cable that is connected to the antenna, see subclause 5.3.

## 3.2 Abbreviations

For the purposes of the present document, the following abbreviations apply:

|               |  |
|---------------|--|
| $\pi/4$ DQPSK | $\pi/4$ Differential Quaternary Phase Shift Keying |
| APC           | Aeronautical Public Correspondence                 |
| AT            | Avionic Termination                                |
| BER           | Bit Error Ratio                                    |
| c/i           | carrier to interference ratio                      |
| DQPSK         | Differential Quaternary Phase Shift Keying         |
| GS            | Ground Station                                     |
| ISI           | Inter Symbol Interference                          |
| OSI           | Open System Interconnect                           |
| PFD           | Power Flux Density                                 |
| ppm           | parts per million                                  |
| PRBS          | Pseudo Random Bit Sequence                         |
| RF            | Radio Frequency                                    |
| rms           | root mean square                                   |
| TDMA          | Time Division Multiple Access                      |
| TFTS          | Terrestrial Flight Telecommunications System       |
| WOW           | Weight On Wheels                                   |

## 3.3 Symbols

For the purposes of the present document, the following symbol applies:

|       |  |
|-------|--|
| $C_0$ | modulator offset (see subclause 6.3.2) |
|-------|--|

---

# 4 Frequency range and radio channel arrangement

The frequency range and channel arrangements are specified in ETS 300 326-2 [1] subclauses 8.8.1.1.1 and 8.8.1.1.2.

## 4.1 Frequency range

The frequency range for terrestrial Aeronautical Public Correspondence (APC) is as follows:

- 1 670 MHz to 1 675 MHz for ground to air use (AT receive);
- 1 800 MHz to 1 805 MHz for air to ground use (AT transmit).

## 4.2 Radio channel arrangement

The Terrestrial Flight Telecommunications System (TFTS) radio frequency channel arrangement provides for 164 pairs of Radio Frequency (RF) channels (one channel for each direction of transmission). The centre frequencies of these channels are given by the following:

- $F_g(n) = 1\,670 + n/33$  MHz;

- $F_a(n) = F_g(n) + 130 \text{ MHz}$ ;

where:

- $F_g(n)$  is the frequency of the  $n$ th ground transmit channel;
- $F_a(n)$  is the frequency of the  $n$ th airborne transmit channel;
- $n$  is the channel number (1 to 164).

Where frequencies have been specified in the present document, they are rounded up with a resolution of 1 Hz.

## 4.3 Modulation

The modulation method used shall be  $\pi/4$  Differential Quaternary Phase Shift Keying ( $\pi/4$  DQPSK). The modulation scheme shall use the phase constellation shown in figure 1.

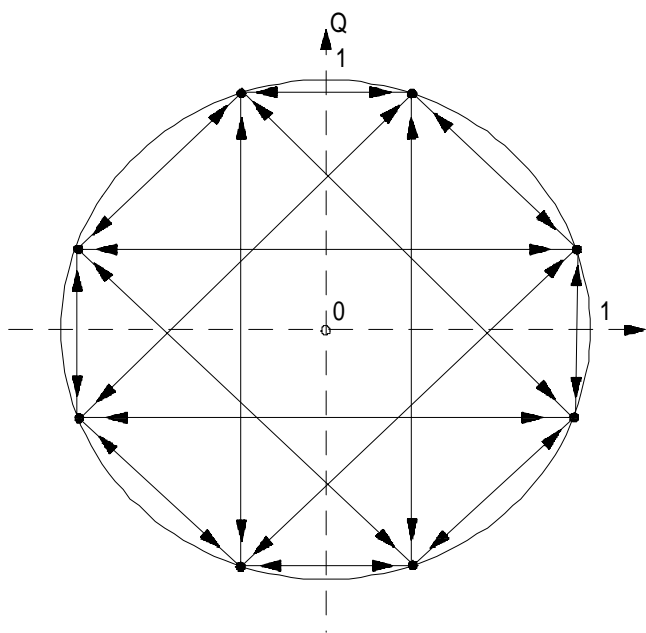

Figure 1:  $\pi/4$  DQPSK constellation



## 5 General aspects of TFTS testing procedures

Two testing procedures are covered by the present document: a testing procedure for the protection and compatibility of the TFTS network equipment and a testing procedure for the protection of other radio services.

### 5.1 Protection of the TFTS network

These tests may be described as assuring that:

- interchange of TFTS equipment from several manufacturers is possible;
- no harm is done to the TFTS network.

### 5.2 Protection of other services

Basic tests to ensure that the level of protection afforded to other services is as has been specified in ETS 300 326-2 [1].

These tests may be described as assuring that no unacceptable interference occurs to other radio services.

### 5.3 Access to signals

The standard interface points of the AT shall be used for testing purposes, see subclause 6.2 of ETS 300 326 part 2 [1]:

Ua interface: This shall be replaced by an equivalent interface at the AT transceiver RF access points which shall allow for the connection of signals coming from or going to the RF test system. Measurements shall be made at the antenna port, unless stated otherwise, using the antenna feed cable.

This test configuration has assumed a cable loss of 3 dB between the diplexer and the antenna port, see figure 2.

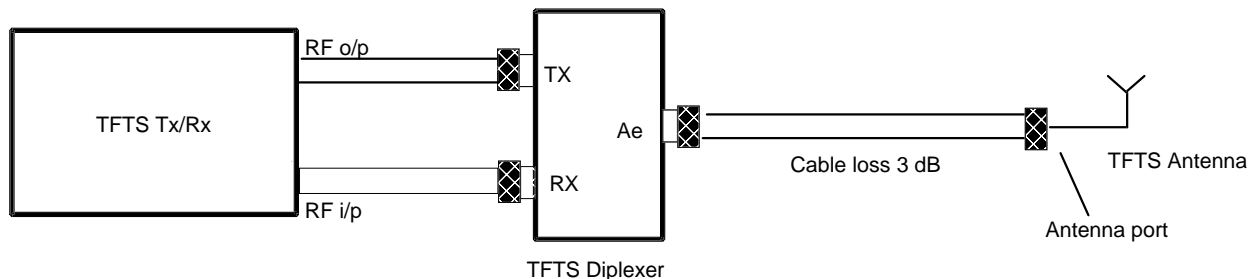

**Figure 2: Antenna port interface point**

### 5.4 Environmental conditions for tests

- temperature: 15 °C to 35 °C;
- relative humidity: 20 % to 75 %;
- pressure: 990 mBar to 1 014 mBar.

Testing under other environmental conditions will have been undertaken by manufacturers according to ARINC characteristic 752 [4] and EUROCAE ED-14C [5] and shall not be repeated for the present document.

### 5.5 Power supply requirements

The power supply shall be in accordance with ARINC characteristic 752 [4] i.e. 115 V AC (nominal) supply at 400 Hz (nominal) single phase.

---

## 6 Tests of radio aspects of the physical layer

The physical layer is the lowest level of the Open System Interconnect (OSI) reference model and supports all of the functions required for the transmission of bit streams on the physical medium (see ETS 300 326 part 2 [1], subclause 8.1).

### 6.1 General

This subclause describes the tests that are necessary to ensure conformance to the required protection criteria for other services operating in the same or adjacent bands to those used by TFTS as given in subclause 4.1 and the tests necessary to ensure that no unacceptable interference is caused to other radio services elsewhere in the radio spectrum.

#### 6.1.1 Documentation

Layer 1 TFTS Radio Interface requirements are given in the following subclauses of ETS 300 326-2 [1]:

- 8.6 Time Division Multiple Access (TDMA) characteristics;
- 8.7 Modulation characteristics;
- 8.8 Radio transmission and reception characteristics;
- 8.10 Radio sub-system link control;
- 8.11 Radio sub-system synchronisation.

#### 6.1.2 Limits for radio measurements for conformance testing

##### 6.1.2.1 Unwanted emissions

ETS 300 326-2 [1] subclauses 8.8.2.5 and 8.8.2.6.

##### 6.1.2.2 Modulator and transmitter accuracy

ETS 300 326-2 [1] subclause 8.7.2.3.

##### 6.1.2.3 Frequency error

ETS 300 326-2 [1] subclause 8.8.1.3.1.

##### 6.1.2.4 Transmitter output power

ETS 300 326-2 [1] subclause 8.8.2.2.1.

##### 6.1.2.5 RF spectrum

ETS 300 326-2 [1] subclause 8.8.2.4.

##### 6.1.2.6 Receiver sensitivity without interferer

ETS 300 326-2 [1] subclause 8.8.3.2.1.

##### 6.1.2.7 Co-channel sensitivity

ETS 300 326-2 [1] subclause 8.8.3.2.3.

### 6.1.2.8 Adjacent channel sensitivity

ETS 300 326-2 [1] subclause 8.8.3.2.4.

### 6.1.3 Test apparatus

The tests require the AT to be set up in various power and frequency configurations which require a suitably interfaced test system to command the AT directly (see subclause 6.1.4.1).

Certain items of standard test equipment are required, these are given in table 1.

**Table 1: Standard test equipment**

| Item                     | Description   |
|--------------------------|---|
| AT control test software | Means of controlling AT functions without a Ground Station (GS) (e.g. RS232 interface on AT with control command set and ability to read data from the AT).   |
| Spectrum Analyser        | Sweep 9 kHz to 12,75 GHz, noise floor typically -148 dBm/Hz. Dynamic range at 1,8 GHz to be 80 dB or greater.   |
| Vector spectrum analyser | Operates at 1,8 GHz, noise floor typically -142 dBm/Hz.   |
| RF Frequency Counter     | Capable of measurement at 1,8 GHz and accuracy better than $2 \times 10^{-8}$ with a suitable external frequency standard input.  |
| Control PC               | To interface with AT control test software.   |
| Data error test set      | Used to generate 9,6 kbit/s data with a $2^{15}-1$ bit length Pseudo Random Bit Sequence (PRBS) with suitable interface to the AT. Capable of integration sufficient to resolve BERs down to $10^{-6}$ . The sequence shall be at least $10^6$ bits long. |
| PRBS generator           | Used to generate 9,6 kbit/s data with a $2^{15}-1$ bit length PRBS. The sequence shall be at least $10^6$ bits long. (Not necessary if data error test set can produce second uncorrelated PRBS).   |
| Complex signal generator | Capable of generating $\pi/4$ DQPSK signals at 1,67 GHz modulated with data from data error test set. Phase noise typically -120 dBc/Hz.  |
| RF power meter           | Capable of power measurement at 1,8 GHz.  |
| Miscellaneous            | 130 MHz generator to provide local oscillator for loopback function, 10 MHz reference, RF mixer, 25 W fixed 50 $\Omega$ power attenuators, variable 50 $\Omega$ attenuators (1 dB and 10 dB steps), RF signal combiners, 50 $\Omega$ load.                |

### 6.1.4 AT testing facilities

There are several facilities without which it is difficult to carry out some of the tests on the AT. The implementation of the following would greatly simplify both the tests and the equipment required to carry them out.

#### 6.1.4.1 Direct control of AT

All of the tests in subclauses 6.2 to 6.8 inclusive require that the AT is set up in a specified state before the measurements are carried out. The ability to directly control the AT in the initial stages of measuring transmitter and receiver parameters greatly improves the validity of the measurements as the initial state of the AT before the test can be guaranteed. Indirect control of the AT, e.g. influencing the power level transmitted from the AT by changing the attenuation in the radio link, could form part of a full functional conformance test which is beyond the scope of the present document. To this end, manufacturers should provide a data port through which the AT may be controlled.

#### 6.1.4.2 Loopback facility

The equipment required for Bit Error Ratio (BER) evaluation may be simplified by the provision of a loop back facility (see figure 3) that bypasses the 9,6 kbit/s signal from the decoder input to encoder output. The encoder-decoder will then be excluded from the test. This allows the AT to be tested with 9,6 kbit/s test signals in continuous modulation mode (see subclause 6.1.4.3).

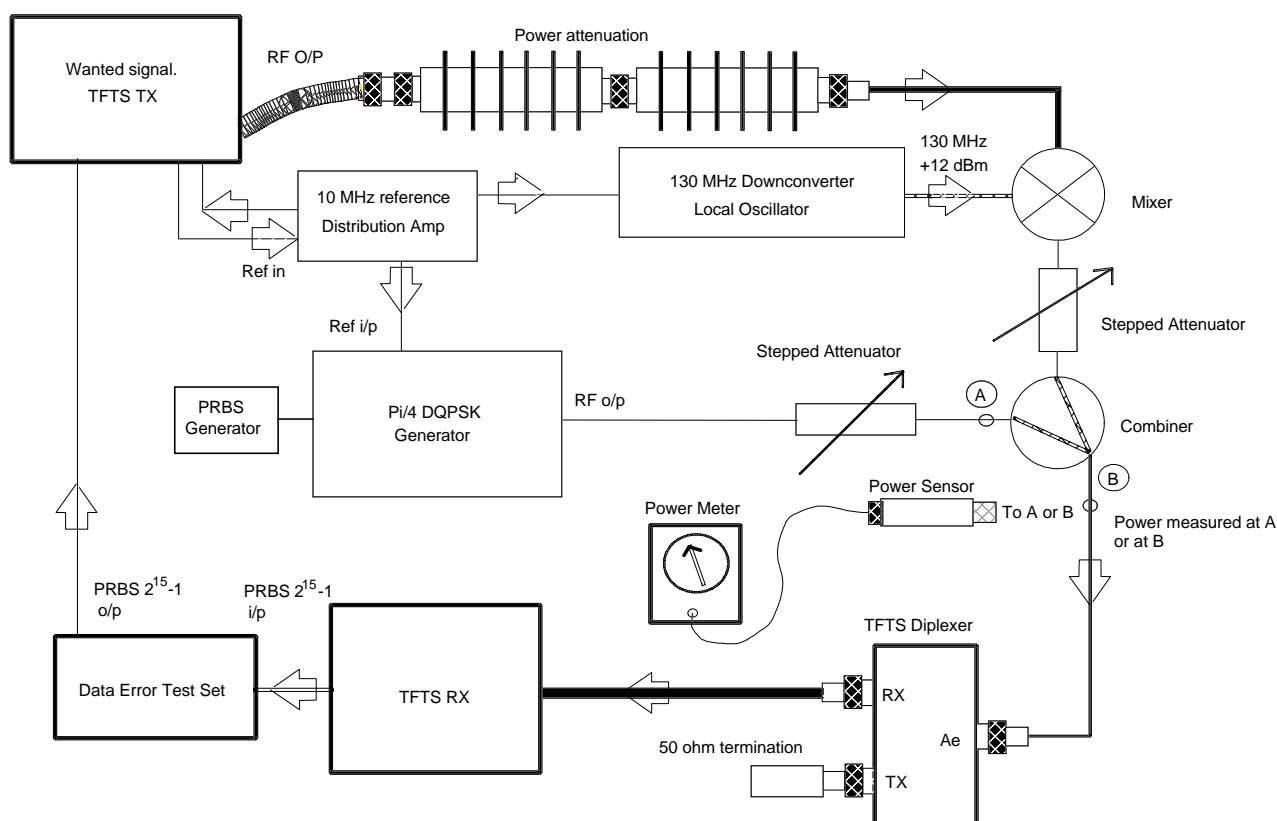

**Figure 3: An example of a loopback facility for co-channel and adjacent channel measurements**

### 6.1.4.3 Continuous modulation mode

The AT should be able to continuously transmit a modulated signal to simulate continuous operation. This signal should be either a 44,2 kbit/s test signal or a composite consisting of four 9,6 kbit/s PRBS in the traffic channels.

#### 6.1.4.3.1 Test signals

The test signal used to simulate voice traffic shall be a  $2^n - 1$  PRBS, where  $n = 15$ , with a bit rate of 9,6 kbit/s.

### 6.1.4.4 Suppressed modulation mode

It shall be possible to operate the AT in a suppressed modulation mode, i.e. transmitting an unmodulated carrier only. This is to simplify the equipment required to perform some of the tests.

### 6.1.4.5 Standby mode

It shall be possible to operate the AT in standby mode, i.e. with all traffic channels switched off.

## 6.1.5 Mean to peak ratio of $\pi/4$ DQPSK modulation

NOTE: This subclause is for information only.

The TFTS system uses  $\pi/4$  DQPSK modulation which has a constant amplitude. After baseband filtering with a root raised cosine filter in the range of 0,35 to 0,4 as specified in ETS 300 326-t 2 [1] subclause 8.7.2.2 the signal contains amplitude modulation components with a peak to mean ratio of approximately 4,5 dB.

In ETS 300 326-2 [1] subclause 8.8.2.2, power levels are quoted without stating whether they are mean or peak values. The present document has been written on the basis that all power levels are quoted as mean power in ETS 300 326-2 [1], except for those relating to unwanted emissions which are quoted as peak power.

## 6.1.6 Uncertainty in measurements

All measurements are quoted with a 95 % level of confidence. Measurement uncertainty has been calculated for each test in accordance with ETR 028 [2].

## 6.1.7 Measurements made under continuous or burst modulation

The combination of relatively slow power ramping and relaxed adjacent channel performance (-37 dBc at  $\pm 30$  kHz from the channel centre frequency) means that the measurement of radio parameters using burst modulation, i.e. with one or more of the traffic channels in a radio channel switched off, would not reveal any more detail than would performing the measurement under continuous modulation with all traffic channels filled. In addition, the use of continuous modulation simplifies the test equipment required, e.g. standard spectrum analysers can be used without the need for time gating.

## 6.1.8 EMC

As TFTS AT equipment is carried on board aircraft, the EMC requirements are under the control of other bodies and are outside the scope of the present document.

## 6.2 Measurement of unwanted emissions

### 6.2.1 General

Unwanted emissions, as defined in paragraph 140 of chapter 1, article 1 of the ITU Radio Regulations [3], consist of out of band and spurious emissions and the two sets of limits for TFTS are specified separately in ETS 300 326-2 [1] subclause 8.8.2.5 for out of band emissions and 8.8.2.6 for spurious emissions.

The measurement of unwanted emissions shall be based on peak power.

Unwanted emissions shall be measured with the diplexer connected.

### 6.2.2 Reference documents and specification

#### 6.2.2.1 Out of band emissions

ETS 300 326-2 [1] subclause 8.8.2.5.

Out of band emissions from the AT shall be better than -69 dBW / 30 kHz at the antenna port, at all frequencies outside the range 1 797,5 MHz to 1 807,5 MHz.

#### 6.2.2.2 Spurious emissions

ETS 300 326-2 [1] subclause 8.8.2.6.

This subclause refers to conducted spurious emissions which shall be measured into a 50  $\Omega$  load with the transmitter set to full power in suppressed modulation mode and in standby mode.

The spurious emissions from the TFTS equipment shall not exceed -58 dBm at the antenna port for frequencies between 9 kHz and 1 GHz. The spurious emissions shall not exceed -48 dBm at the antenna port for frequencies between 1 GHz and 12,75 GHz.

This shall be verified by conducted measurements in the band 9 kHz to 12,75 GHz, excluding the AT transmit band from 1 800 MHz to 1 805 MHz.

### 6.2.3 Purpose of the tests

The purpose of the tests is to confirm that the AT can operate without emitting harmful out of band or spurious energy.

These tests are necessary to ensure that the AT will not cause unacceptable levels of interference to other channels of the TFTS network or to other radio services in bands adjacent to those allocated to TFTS.

### 6.2.4 Method of measurement

#### 6.2.4.1 Out of band emissions

- a) The AT shall be set in continuous modulation mode;
- b) the transmitter shall be set to channel 1 (1 800,030 303 MHz);
- c) the mean output power of the transmitter shall be set to give +40 dBm at the antenna port;
- d) the spectrum analyser shall be swept from 1 697,5 MHz to 1 797,5 MHz;
- e) there shall be no emissions above -69 dBW in 30 kHz at the antenna port;
- f) the main radio shall be set to channel 164 (1 804,969 696 MHz);
- g) the spectrum analyser shall be swept from 1 807,5 MHz - 1 907,5 MHz;
- h) there shall be no emissions above -69 dBW in 30 kHz at the antenna port.

#### 6.2.4.2 Spurious emissions

- a) the transmitter shall be set to channel 1 (1 800,030 303 MHz);
- b) the mean output power of the transmitter shall be set to give +40 dBm at the antenna port;
- c) the transmitter shall be set to suppressed modulation mode;
- d) the spectrum analyser shall be swept between 9 kHz and 1 GHz with a measurement bandwidth of 30 kHz;
- e) the peak power level of any spurious signal shall be below -58 dBm;
- f) the spectrum analyser shall be swept from 1 000 MHz to 1 800 MHz and 1 805 MHz to 12,75 GHz with a measurement bandwidth of 30 kHz;
- g) the peak power level of any spurious signal shall be below -48 dBm;
- h) steps d) to g) shall be repeated with the transmitter set to channel 82 (1 802,484 848 MHz);
- j) steps d) to g) shall be repeated with the transmitter set to channel 164 (1 804,969 696 MHz);
- k) the AT shall be set to standby mode;
- l) steps c) to j) shall be repeated including measurements in the band 1 800 MHz to 1 805 MHz.

### 6.2.5 Test bank characteristics

The spectrum analyser shall be connected to the diplexer via a 50  $\Omega$  power attenuator.

The receiver output of the diplexer shall be connected to the receiver input of the AT, see figure 4.

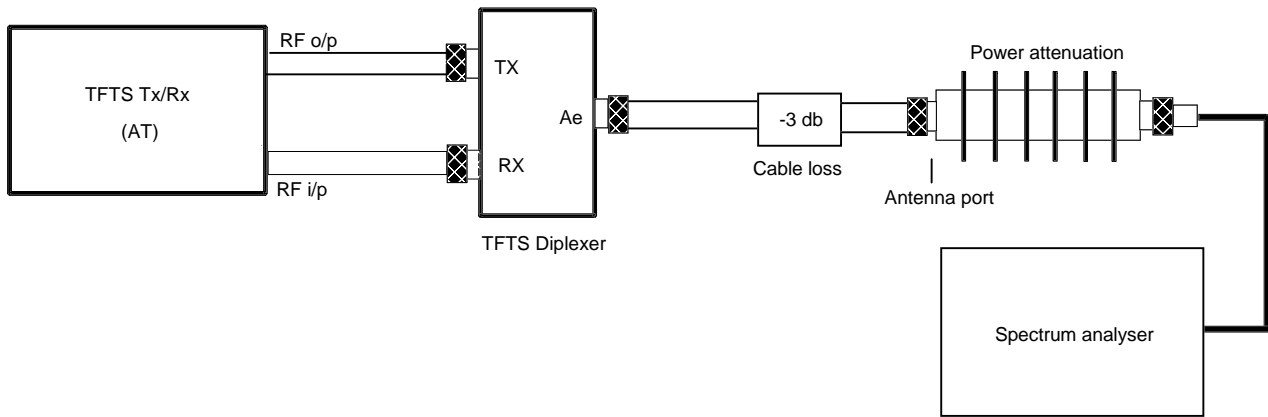

**Figure 4: Unwanted emissions measurement equipment**

## 6.2.6 Measurement uncertainty

The maximum uncertainty for the measurement shall be  $\pm 4$  dB according to ETR 028 [2].

## 6.3 Modulator and transmitter accuracy

### 6.3.1 General

The transmitter accuracy is evaluated by the root mean square (rms) value of an error vector which is representative of the cumulative Inter Symbol Interference (ISI) and equipment noise at the sampling instants (one sampling time per symbol).

The rms vector magnitude takes into account the following:

- modulator impairments (quadrature offset, phase and magnitude errors in the modulation states);
- modulation filtering linear distortion;
- local oscillator phase noise;
- complementary filter distortion; and
- power amplifier non linearity.

It is measured after compensation of the modulator offset and transceiver frequency and magnitude offsets, including effects due to Doppler shift.

### 6.3.2 Reference documents and specification

ETS 300 326-2 [1] subclauses 8.7.2.3 and 8.8.2.7.

- rms error (averaged on the general slot information field):
  - $e(\text{rms}) \leq 14\%$  (referred to the magnitude of the transmitter output);
- modulator offset:
  - $C_0 \leq 5\%$  (referred to the magnitude of the transmitter output).

### 6.3.3 Purpose of the test

The purpose of the test is to check the quality of the transmitter chain of the AT equipment.

### 6.3.4 Method of measurement

- a) the AT shall be set in continuous modulation mode;
- b) the transmitter shall be set to channel 1 (1 800,030 303 MHz);
- c) the mean output power of the transmitter shall be set to give +40 dBm at the antenna port;
- d) the output power shall be reduced using the power attenuator and variable attenuator to a level suitable for the vector analyser;
- e) a sample of the known PRBS data shall be entered into the vector analyser and the analyser shall be synchronized to this data sample;
- f) the analyser shall be set to display the magnitude of the error vector. This shall be compared to the limit value of 14 %;
- g) the analyser shall be set to display the modulator offset. This shall be compared to the limit value of 5 %;
- h) steps b) to g) shall be repeated with the transmitter set to channel 82 (1 802,484 848 MHz);
- j) steps b) to g) shall be repeated with the transmitter set to channel 164 (1 804,969 697 MHz).

### 6.3.5 Test bank characteristics

Vector analyser, fixed and variable power attenuators, equipment for continuous modulation mode.

### 6.3.6 Measurement uncertainty

The uncertainty is  $\pm 3$  % based on the typical specification of a vector analyser.

## 6.4 Frequency error

### 6.4.1 General

This test can only measure short term accuracy, verification of long term accuracy shall be by documentary evidence.

### 6.4.2 Reference documents and specification

ETS 300 326-2 [1] subclause 8.8.1.3.1.

The fractional error between the actual transmitted frequency or the centre frequency of the receiver and the nominal frequency shall be less than  $2 \times 10^{-7}$ .

### 6.4.3 Purpose of the test

The purpose of the test is to verify the ability of the AT to transmit the signal on the correct frequency assignment for the channel on which it is transmitting within the tolerances defined in subclause 6.4.2 in order to prevent interference to other TFTS channels.

### 6.4.4 Method of measurement

- a) the AT shall be set to suppressed modulation mode;
- b) the AT mean output power shall be set to give +40 dBm at the antenna port;
- c) the transmitter shall be set to channel 1 (1 800,030 303 MHz);
- d) the transmitted frequency shall be recorded at the antenna port;



e) The fractional error shall then be calculated as follows:

$$\text{fractional error} = \frac{|(\text{measured frequency} - \text{nominal channel frequency})|}{\text{nominal channel frequency}}$$

f) steps c) to e) shall be repeated with the AT transmitter set to channel 82 (1 802,484 848 MHz);

g) steps c) to e) shall be repeated with the AT transmitter set to channel 164 (1 804,969 696 MHz);

h) the fractional error in the transmit frequency measured for each channel in steps a) to g) shall be compared to the limit value of  $2 \times 10^{-7}$ . For guidance, this corresponds to the measured frequency being contained in the interval  $(f_{\text{nom}} - 360)$  Hz to  $(f_{\text{nom}} + 360)$  Hz, where  $f_{\text{nom}}$  is the nominal frequency in Hz of the channel to which the transmitter is set.

## 6.4.5 Test bank characteristics

The test equipment shall consist of a frequency meter and appropriate RF attenuation to reduce the transmit power to a level suitable for the meter.

The TFTS transmitter shall be connected to the diplexer by the cable supplied by the manufacturer and the diplexer receiver port shall be terminated in a 50  $\Omega$  load.

## 6.4.6 Measurement uncertainty

The measurement uncertainty which depends on the frequency reference used by the frequency counter shall be better than 0,02 ppm.

## 6.5 Mean transmitter output power

### 6.5.1 General

The first part of this subclause specifies tests to verify the highest and lowest mean power output of the AT transmitter and the automatic power control. The operation of the reduction in power level that is specified when the AT receives a Weight On Wheels (WOW) TRUE signal, (i.e. when the aircraft is on the ground) cannot be tested as the WOW indication from the aircraft cannot be simulated. Verification of operation of the power reduction in response to a WOW signal shall be by documentary evidence.

### 6.5.2 Mean transmitter power output under continuous transmission

The power output under burst conditions will not be measured for the reasons given in subclause 6.1.7.

#### 6.5.2.1 Reference documents and specification

ETS 300 326-2 [1] subclauses 8.8.2.2.1 and 8.8.2.5.

The nominal mean transmit power shall be +40 dBm (+2, -1 dB) at the antenna port. The lowest value of the mean transmit power shall be  $75 \pm 2$  dB below nominal. The automatic power control shall adjust the output power relative to the nominal mean level in the range +0 to -75 dB in equal steps of 5 dB. The tolerance of each step shall be  $\pm 2$  dB.

When WOW is TRUE, the mean power level shall be reduced to +25 (+4, -3 dB) dBm, also measured at the antenna port.

#### 6.5.2.2 Purpose of the test

The purpose of the test is to verify that the AT output powers both with and without automatic power control action are within the ranges specified in subclause 6.5.2.1 when measured at the antenna port. This ensures that the AT will not cause interference to other ground stations in the TFTS network by transmitting at too high a power level.

### 6.5.2.3 Method of measurement

- a) the AT shall be set in continuous modulation mode;
- b) the transmitter shall be set to channel 82 (1 802,484 848 MHz);
- c) the AT mean output power shall be set to give +40 dBm at the antenna port;
- d) a power meter shall be connected to the antenna port via suitable external power attenuators;
- e) The mean output power shall be calculated as follows:
  - meter reading + power attenuation – any calibration required for the meter and power sensor and shall be within the range specified in subclause 6.5.2.1;
- f) the automatic power control shall be set to reduce the output power by 75 dB;
- g) the external power attenuation shall be reduced to give a measurable mean power level at the power meter;
- h) the lowest mean output power shall be checked against the range specified in section e) and shall be within the range specified in subclause 6.5.2.1;
- j) the automatic power control shall be set to increase the power in 5 dB steps. The measured output power at each step shall be calculated as in section e) and its value at each step shall be compared to  $(-35 + 5n) \pm 2$  dBm, where  $n$  is the step number and steps 0 and 15 corresponding to the lowest and highest output powers respectively.

NOTE: It may be necessary to adjust the external power attenuation to take account of the dynamic range of the power meter when increasing the output power in step j).

### 6.5.2.4 Test bank characteristics

The test equipment shall consist of a RF power meter (measuring mean power), any associated power sensor and cabling and power attenuators.

The TFTS transmitter shall be connected to the diplexer by the manufacturer supplied cable and the diplexer receiver port shall be terminated in a 50  $\Omega$  load, see figure 5.

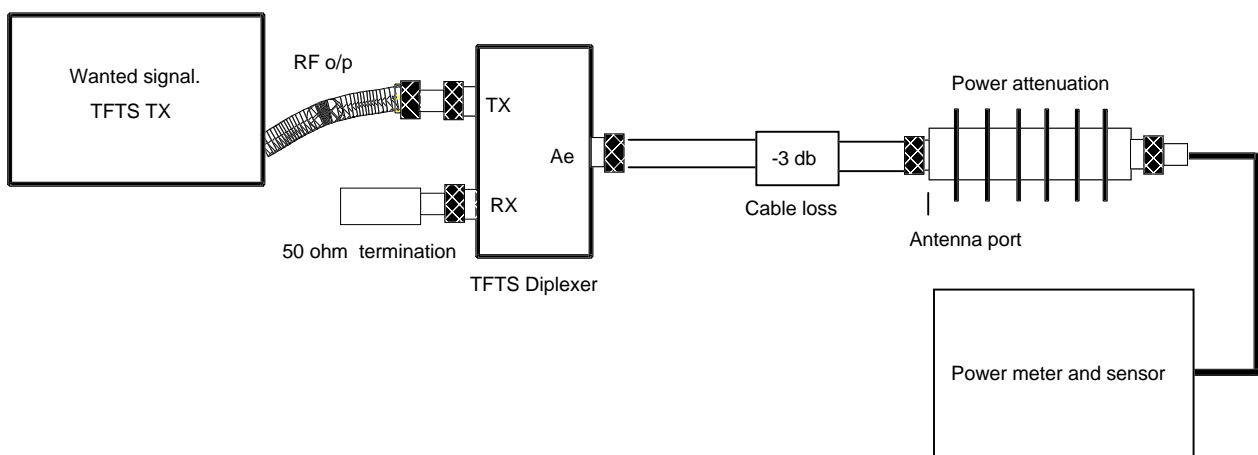

Figure 5: Transmitter power measurement test equipment

### 6.5.2.5 Measurement uncertainty

The maximum uncertainty shall be  $\pm 1$  dB according to ETR 028 [2].

## 6.6 RF spectrum mask

### 6.6.1 General

This subclause describes a test to verify the transmitter spectrum mask.

### 6.6.2 Reference documents and specification

ETS 300 326-2 [1] subclause 8.8.2.4.

The spectrum mask is specified in table 2 as the maximum power level at several frequencies above and below the nominal transmit frequency. The frequency offsets shall be measured from the nominal centre frequency, not from the actual value, and power levels are given relative to the transmit power at the nominal frequency.

**Table 2: Transmitter mask**

| Frequency offset (kHz)   | dB relative to power at centre frequency | Measurement bandwidth (Hz) |
|--|--|----------------------------|
| ± 11,3   | +1                                       | 300                        |
| ± 14,5   | -20                                      | 300                        |
| ± 15,6   | -35                                      | 300                        |
| ± 30   | -37                                      | 300                        |
| ± 60   | -49                                      | 300                        |
| ± 120  | -65                                      | 300                        |
| ± 2 500  | -70                                      | 1 000                      |
| ± 5 000  | -75                                      | 1 000                      |
| NOTE: The attenuation at ± 120 kHz is specified as -65 dB but manufacturers are recommended to attain the -68 dB figure. |  |                            |

The spectrum mask is defined by joining the points given in the table by straight lines.

### 6.6.3 Purpose of the test

The purpose of the test is to verify the conformance of the AT spectrum mask to the requirements of ETS 300 326-2 [1]. The measurement is necessary to verify that the AT does not transmit power in adjacent channels in excess of the levels specified.

The test shall be carried out in continuous modulation mode only and on channels 1, 82 and 164. The RF mask shall not be measured in burst mode for the reasons given in subclause 6.1.7.

### 6.6.4 Method of measurement

- a) the AT shall be set in continuous modulation mode;
- b) the AT mean output power shall be set to give +40 dBm at the antenna port;
- c) the radio shall be set to transmit on channel 1 (1 800,030 303 MHz);
- d) the signal shall be averaged at the antenna port over at least 20 sweeps on a spectrum analyser with the measurement bandwidth shown in table 2. The mean of the transmit spectrum shall be compared with the values of the transmit mask as described in table 2;
- e) steps c) to d) shall be repeated with the AT set to channel 82 (1 802,484 848 MHz);
- f) steps c) to d) shall be repeated with the AT set to channel 164 (1 804,969 697 MHz).

### 6.6.5 Test bank characteristics

The test equipment shall consist of a spectrum analyser, a PRBS generator and RF attenuators to reduce the output power to a suitable level for the analyser. The analyser should be programmed to display the wanted RF mask.

## 6.6.6 Measurement uncertainty

The uncertainty in the measurement will depend on the relative accuracy of the analyser used. At relative powers of 0 dB to -50 dB a typical level of uncertainty has been calculated as  $\pm 1,7$  dB. At relative powers of 0 to -50 dB, the maximum uncertainty for the measurement shall be  $\pm 2$  dB according to ETR 028 [2].

## 6.7 Receiver sensitivity

### 6.7.1 General

This subclause describes two sets of tests that measure the Bit Error Rate (BER) response of the AT receiver under static conditions in the presence of:

- a) thermal noise only;
- b) signals producing in-band intermodulation products.

The receiver shall not be tested under dynamic conditions.

### 6.7.2 Receiver sensitivity with thermal noise

#### 6.7.2.1 Reference documents and specification

ETS 300 326-2 [1] subclause 8.8.3.2.1.

An input signal from a source modulated by a  $2^{15} - 1$  PRBS of at least  $10^6$  bits in length, producing a mean Power Flux Density (PFD) of  $-113$  dBW/m<sup>2</sup> at a 1 dBi airborne station antenna shall give a BER of  $10^{-3}$  or better at the demodulator output.

$-113$  dBW/m<sup>2</sup> is equal to  $-83$  dBm/m<sup>2</sup>.

The antenna aperture of 1 dBi antenna at 1 670 MHz is  $-25$  dB relative to one square metre.

Therefore the power at the antenna port of the diplexer (assuming 3 dB feeder loss of which 2 dB appear between the diplexer and the antenna) is  $-110$  dBm ( $= -83 -25 -2$ ).

#### 6.7.2.2 Purpose of the test

The purpose of this test is to establish that the receiver of the AT is capable of producing a BER of  $10^{-3}$  at the demodulator output given the specified input signal with no interference other than that due to internal effects within the AT itself.

#### 6.7.2.3 Method of measurement

The wanted signal is produced using the AT in loopback mode.

- a) the AT shall be set to continuous modulation mode;
- b) the transmitter shall be set to channel 82 (1 802,484 848 MHz);
- c) the automatic power control shall be set to give an output power at the lowest level available, i.e. 75 dB below full power;
- d) the stepped attenuator shall be set to give a measured mean power of  $-110$  dBm at the antenna port of the diplexer taking into account the loss due to the power combiner;
- e) the BER at the demodulator output shall be compared to the maximum admissible value of  $10^{-3}$ .

#### 6.7.2.4 Test bank characteristics

The loopback setup (see figure 3) using a data error test set should be used.

#### 6.7.2.5 Measurement uncertainty

The maximum measurement uncertainty of the input power level shall be  $\pm 1,5$  dB according to ETR 028 [2].

### 6.7.3 Receiver sensitivity with in-band intermodulation products

#### 6.7.3.1 Reference documents and specification

ETS 300 326-2 [1] subclause 8.8.3.2.2.

Two unmodulated interfering carriers 55 dB above the wanted signal shall be applied, spaced 6 channels and 12 channels from the wanted signal. Both interfering carriers shall be on the same side of the wanted signal, i.e. either both at a higher frequency or both at a lower frequency. The wanted signal shall be as specified for the test in subclause 6.7.2.1. Under these conditions, the BER at the demodulator output shall be  $5 \times 10^{-3}$  or better.

#### 6.7.3.2 Purpose of the test

The purpose of this test is to establish that the receiver of the AT is capable of producing the specified BER given that the input signal consists of the wanted signal as specified in subclause 6.7.2.1 combined with the intermodulation products of two off-channel signals which fall in the wanted channel.

#### 6.7.3.3 Method of measurement

The wanted signal shall be produced using the AT in loopback mode (see test bank characteristics subclause 6.7.3.4).

- a) the AT shall be set to continuous modulation mode;
- b) the transmitter shall be set to channel 82 (1 802,484 848 MHz);
- c) the automatic power control shall be set to give an output power at the lowest level available, i.e. 75 dB below full power;
- d) the stepped attenuator shall be set to give a measured mean power of  $-110$  dBm at the antenna port of the diplexer taking into account the loss due to the power combiner;
- e) two interfering signals shall be injected, each an unmodulated carrier with a mean power of  $-55$  dBm, i.e.  $(-110 + 55)$  dBm. One signal shall be on channel 88 (1 802,666 667 MHz), the other shall be on channel 94 (1 802,848 485 MHz);
- f) the BER at the demodulator output shall be compared to the maximum admissible value of  $5 \times 10^{-3}$ .

#### 6.7.3.4 Test bank characteristics

A loopback test setup should be used using a data error test set and two signal generators. Figure 6 gives an example test setup.

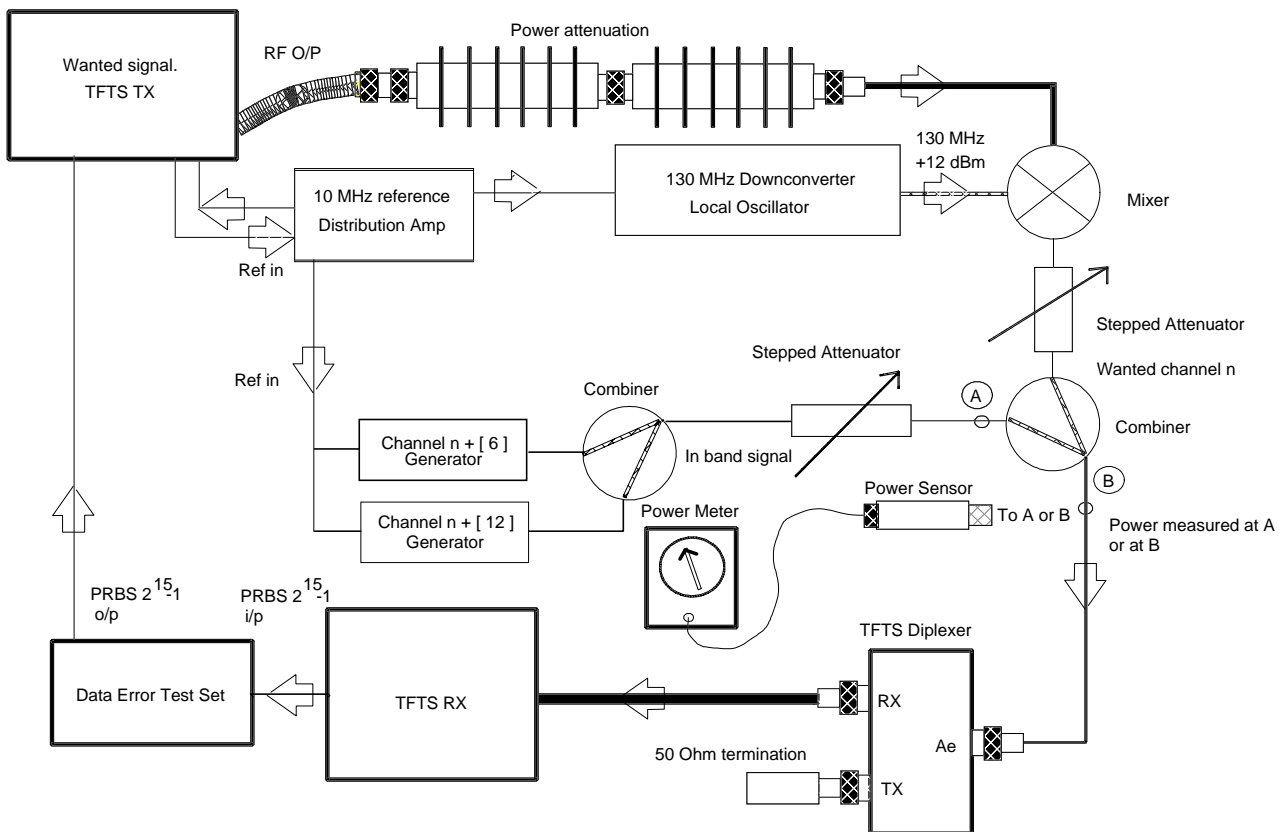

**Figure 6: An example of an in band intermodulation sensitivity test setup**

NOTE: The 3 dB cable loss allowance is distributed as 2 dB on the antenna side and 1 dB on the equipment side.

### 6.7.3.5 Measurement uncertainty

The maximum measurement uncertainty of the input power level shall be  $\pm 1,5$  dB.

## 6.8 Co-channel and adjacent channel sensitivity

### 6.8.1 General

This subclause describes tests to verify the operation of the AT receiver in the presence of interfering signals in co and adjacent channels.

### 6.8.2 Reference document and specification

ETS 300 326-2 [1] subclause 8.8.3.2.3.

An interfering signal spaced  $n$  channel(s) from the wanted signal, modulated by a PRBS of  $10^6$  bits in length and differing from the wanted signal, shall give a BER of  $5 \times 10^{-3}$  or better at the demodulator output. The carrier to interference ratio (c/i) is as shown in table 3.

**Table 3: Interferer levels**

| n | c/i (dB) |
|---|----------|
| 0 | +20      |
| 1 | -20      |
| 2 | -34      |
| 3 | -38      |
| 4 | -40      |
| 8 | -40      |

The wanted PFD shall be as specified in subclause 6.7.2.1 of the present document.

### 6.8.3 Purpose of the test

The purpose of the test is to ensure that the AT BER is not affected by signals from unwanted ground stations on channels and with relative power levels as described in table 3.

### 6.8.4 Method of measurement

- a) the transmitter shall be set to channel 82 (1 802,484 848 MHz), and the AT shall be set to continuous modulation mode;
- b) the automatic power control shall be set to give an output power at the lowest level available, i.e. 75 dB below full power;
- c) a stepped attenuator shall be connected to the transmitter power amplifier output after the power attenuators and set to give a measured mean power of  $-110$  dBm at the antenna port of the diplexer, taking into account the loss due to the power combiner;
- d) the wanted signal shall be transmitted using the AT in loopback mode using the data error test set;
- e) the unwanted  $\pi/4$  DQPSK signal shall be injected at the frequency of channel 82 from a generator modulated by a  $2^{15} - 1$  PRBS of at least  $10^6$  bits in length which is uncorrelated with that providing the wanted signal. This signal shall be such that it is incident on the diplexer antenna port with a power level of  $-130$  dBm, i.e. 20 dB below the wanted signal;
- f) the BER at the demodulator output shall be compared to the maximum admissible value of  $5 \times 10^{-3}$ ;
- g) steps e) and f) shall be repeated with the unwanted signal at the frequencies and powers relative to the wanted signal as given in table 3;
- h) in each case the BER at the demodulator output shall be  $5 \times 10^{-3}$  or better.

### 6.8.5 Test bank characteristics

An example test bank might include:

the AT in loopback mode, data error test set,  $\pi/4$  DQPSK generator (see figure 7).

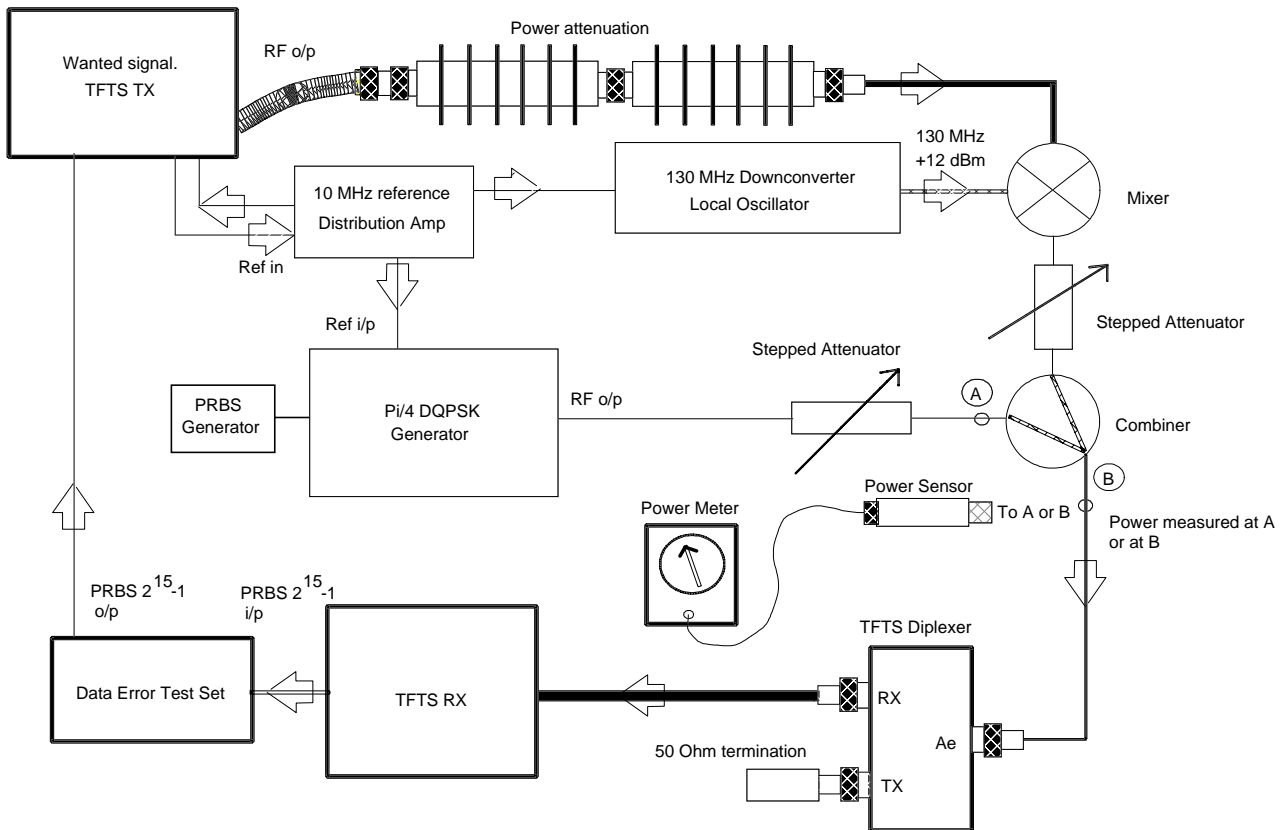

Figure 7: An example co-channel and adjacent channel sensitivity test set-up

### 6.8.6 Measurement uncertainty

The maximum measurement uncertainty of the input power level shall be  $\pm 1,5$  dB.



---

## History

| <b>Document history</b> |               |                                 |         |                          |
|-------------------------|---------------|---------------------------------|---------|--------------------------|
| Edition 1               | October 1996  | prETS 300 789 on Public Enquiry | PE 116: | 1996-10-21 to 1997-02-14 |
| V1.1.1                  | December 1997 | Vote                            | V 9807: | 1997-12-16 to 1998-02-13 |
| V1.1.1                  | March 1998    | Publication                     |         |                          |
|                         |               |                                 |         |                          |
|                         |               |                                 |         |                          |