

EN 300 748 V1.1.2 (1997-08)

European Standard (Telecommunications series)

Digital Video Broadcasting (DVB); Multipoint Video Distribution Systems (MVDS) at 10 GHz and above

European Broadcasting Union



Union Européenne de Radio-Télévision

DVB
Digital Video
Broadcasting



European Telecommunications Standards Institute

Reference

REN/JTC-00DVB-68 (6xc00idc.PDF)

Keywords

DVB, digital, video, broadcasting, MPEG, TV,
multipoint

ETSI Secretariat

Postal address

F-06921 Sophia Antipolis Cedex - FRANCE

Office address

650 Route des Lucioles - Sophia Antipolis
Valbonne - FRANCE
Tel.: +33 4 92 94 42 00 Fax: +33 4 93 65 47 16
Siret N° 348 623 562 00017 - NAF 742 C
Association à but non lucratif enregistrée à la
Sous-Préfecture de Grasse (06) N° 7803/88

X.400

c= fr; a=atlas; p=etsi; s=secretariat

Internet

secretariat@etsi.fr
<http://www.etsi.fr>

Copyright Notification

No part may be reproduced except as authorized by written permission.
The copyright and the foregoing restriction extend to reproduction in all media.

© European Telecommunications Standards Institute 1997.
© European Broadcasting Union 1997.
All rights reserved.

Contents

Intellectual Property Rights.....	4
Foreword	4
1 Scope.....	5
2 Normative references	5
3 Symbols and abbreviations	6
3.1 Symbols	6
3.2 Abbreviations.....	6
4 Transmission system.....	7
4.1 System definition	7
4.2 Adaptation to MVDS transmitter characteristics	8
4.3 Interfacing.....	8
4.4 Channel coding	9
4.4.1 Transport multiplex adaptation and randomization for energy dispersal.....	9
4.4.2 Outer coding (Reed-Solomon), interleaving and framing	10
4.4.3 Inner coding (convolutional).....	12
4.5 Baseband shaping and modulation.....	13
5 Error performance requirements	14
Annex A (normative): Signal spectrum at the modulator output	15
Annex B (informative): Conceptual system description.....	17
Annex C (informative): Examples of bit rates versus MVDS transmitter bandwidth	19
Annex D (informative): Examples of possible use of the System	20
Annex E (informative): Bibliography.....	21
History	22

Intellectual Property Rights

IPRs essential or potentially essential to the present document may have been declared to ETSI. The information pertaining to these essential IPRs, if any, is publicly available for **ETSI members and non-members**, and can be found in ETR 314: "*Intellectual Property Rights (IPRs); Essential, or potentially Essential, IPRs notified to ETSI in respect of ETSI standards*", which is available **free of charge** from the ETSI Secretariat. Latest updates are available on the ETSI Web server (<http://www.etsi.fr/ipr>).

Pursuant to the ETSI Interim IPR Policy, no investigation, including IPR searches, has been carried out by ETSI. No guarantee can be given as to the existence of other IPRs not referenced in ETR 314 (or the updates on <http://www.etsi.fr/ipr>) which are, or may be, or may become, essential to the present document.

Foreword

This second edition, previously as an ETS now an EN, contains changes of an entirely editorial nature as follows:

- 1) add the DVB logo to the front page of the deliverable;
- 2) change the title from: "Digital broadcasting systems for television, sound and data services; etc." to "Digital Video Broadcast (DVB); etc.";
- 3) add in the foreword the DVB acknowledgement.

This European Standard (Telecommunications series) has been produced by the Joint Technical Committee (JTC) of the European Broadcasting Union (EBU), Comité Européen de Normalisation ELECTrotechnique (CENELEC) and the European Telecommunications Standards Institute (ETSI).

NOTE: The EBU/ETSI JTC was established in 1990 to co-ordinate the drafting of standards in the specific field of broadcasting and related fields. Since 1995 the JTC became a tripartite body by including in the Memorandum of Understanding also CENELEC, which is responsible for the standardization of radio and television receivers. The EBU is a professional association of broadcasting organizations whose work includes the co-ordination of its members' activities in the technical, legal, programme-making and programme-exchange domains. The EBU has active members in about 60 countries in the European broadcasting area; its headquarters is in Geneva *.

* European Broadcasting Union

Case Postale 67

CH-1218 GRAND SACONNEX (Geneva)

Switzerland

Tel: +41 22 717 21 11

Fax: +41 22 717 24 81

Digital Video Broadcasting (DVB) Project

Founded in September 1993, the DVB Project is a market-led consortium of public and private sector organizations in the television industry. Its aim is to establish the framework for the introduction of MPEG-2 based digital television services. Now comprising over 200 organizations from more than 25 countries around the world, DVB fosters market-led systems, which meet the real needs, and economic circumstances, of the consumer electronics and the broadcast industry.

Proposed national transposition dates	
Date of adoption of this EN:	18 October 1996
Date of latest announcement of this EN (doa):	31 January 1997
Date of latest publication of new National Standard or endorsement of this EN (dop/e):	31 July 1997
Date of withdrawal of any conflicting National Standard (dow):	31 July 1997

1 Scope

The present document describes the modulation and channel coding system (denoted the "System" for the purposes of the present document) for the distribution of digital multi-programme Television (TV) / High Definition Television (HDTV) by Multipoint Video Distribution Systems (MVDS) in the 40 GHz band. The System described in the present document is based on that described in EN 300 421 for 11/12 GHz satellite services (see annex E, bibliography).

It allows the same consumer Integrated Receiver Decoder (IRD) to be used for either service, when used with a Low Noise Block (LNB) down-converter for the appropriate frequency band.

The frequency band 40,5 to 42,5 GHz has been harmonized within the European Conference of Post and Telecommunications Administrations (CEPT) under Recommendation T/R 52-01.

The System however, is applicable to other frequency bands above 10 GHz.

The System uses Quaternary Phase Shift Keying (QPSK) modulation and concatenated error protection strategy based on a convolutional code and shortened Reed-Solomon (RS) code.

The System is suitable for use on different MVDS transmitter bandwidths.

Compatibility with Moving Pictures Experts Group - 2 (MPEG-2) coded TV services (see ISO/IEC 13818-1 [1]), with a transmission structure synchronous with the packet multiplex, is provided.

Exploitation of the multiplex flexibility allows the use of the transmission capacity for a variety of TV service configurations, including sound and data services.

All service components are Time Division Multiplexed (TDM) on a single digital carrier.

The present document:

- gives a general description of the System for MVDS digital TV transmission;
- specifies the digitally modulated signal in order to allow compatibility between pieces of equipment developed by different manufacturers. This is achieved by describing in detail the signal processing principles at the modulator side, while the processing at the receive side is left open to different implementation solutions. However, it is necessary in the present document to refer to certain aspects of reception;
- identifies the global performance requirements and features of the System, in order to meet the service quality targets.

2 Normative references

References may be made to:

- a) specific versions of publications (identified by date of publication, edition number, version number, etc.), in which case, subsequent revisions to the referenced document do not apply; or
- b) all versions up to and including the identified version (identified by "up to and including" before the version identity); or
- c) all versions subsequent to and including the identified version (identified by "onwards" following the version identity); or
- d) publications without mention of a specific version, in which case the latest version applies.

A non-specific reference to an ETS shall also be taken to refer to later versions published as an EN with the same number.

- [1] ISO/IEC 13818-1 (November 1994): "Coding of moving pictures and associated audio".
- [2] Forney, G.D. IEEE Trans. Comm. Tech., COM-19, pp. 772-781, (October 1971): "Burst-correcting codes for the classic bursty channel".
- [3] Intelsat Earth Station Standards (IESS) No. 308, revision 6 (26 October 1990): "Performance characteristics for Intermediate Data Rate (IDR) digital carriers".

3 Symbols and abbreviations

3.1 Symbols

For the purposes of the present document, the following symbols apply:

α	roll-off factor
C/N	Signal-to-Noise ratio
d_{free}	convolutional code free distance
E_b/N_0	ratio between the energy per useful bit and twice the noise power spectral density
f_N	Nyquist frequency
G_1, G_2	convolutional code generators
$g(x)$	RS code generator polynomial
I	Interleaving depth (bytes)
I, Q	In-phase, Quadrature phase components of the modulated signal
j	branch index of the interleaver
K	convolutional code constraint length
M	convolutional interleaver branch depth for $j = 1$, $M = N/I$
N	error protected frame length (bytes)
$p(x)$	RS field generator polynomial
r_m	in-band ripple (dB)
R_s	symbol Rate corresponding to the bilateral Nyquist bandwidth of the modulated signal
R_u	useful bit Rate after MPEG-2 transport multiplexer
R_u'	bit rate after RS outer coder
T	number of bytes which can be corrected in RS error protected packet
T_s	symbol period
X, Y	di-bit stream after rate 1/2 convolutional coding

3.2 Abbreviations

For the purposes of the present document, the following abbreviations apply:

AWGN	Additive White Gaussian Noise
BB	BaseBand
BER	Bit Error Ratio
BSS	Broadcast Satellite Service
BW	BandWidth
CCITT	International Telegraph and Telephone Consultative Committee (now ITU-T)
DTH	Direct To Home
FDM	Frequency Division Multiplex
FEC	Forward Error Correction
FIFO	First-In, First-Out shift register
FIR	Finite Impulse Response
FSS	Fixed Satellite Service
HDTV	High Definition TeleVision
HEX	HEXadecimal notation
IF	Intermediate Frequency
IMUX	Input MULTipleXer - filter
IRD	Integrated Receiver Decoder
MPEG	Moving Pictures Experts Group
MSB	Most Significant Bit
MUX	MULTipleX
MVDS	Multipoint Video Distribution System
OBO	Output Back Off
OCT	OCTal notation
OMUX	Output MULTipleXer - filter
P	Puncturing
PDH	Plesiochronous Digital Hierarchy

PRBS	Pseudo Random Binary Sequence
PSK	Phase Shift Keying
QEF	Quasi-Error-Free
QPSK	Quaternary PSK
R	Randomized sequence
RF	Radio Frequency
RS	Reed-Solomon
SMATV	Satellite Master Antenna TeleVision
TBD	To Be Defined
TDM	Time Division Multiplex
TV	TeleVision
TWTA	Travelling Wave Tube Amplifier

4 Transmission system

4.1 System definition

The System is defined as the functional block of equipment performing the adaptation of the baseband TV signals from the output of the MPEG-2 transport multiplexer, to the MVDS channel characteristics.

The following processes shall be applied to the data stream (see figure 1):

- transport multiplex adaptation and randomization for energy dispersal;
- outer coding (i.e. Reed-Solomon);
- convolutional interleaving;
- inner coding (i.e. punctured convolutional code);
- baseband shaping for modulation;
- modulation.

The System functional description is given in annex B.

MVDS services at millimetric frequency bands are particularly affected by power limitations, therefore ruggedness against noise and interference shall be the main design objective, rather than spectrum efficiency.

To achieve a very high power efficiency without excessively penalizing the spectrum efficiency, the System shall use QPSK modulation and the concatenation of convolutional and RS codes.

The convolutional code is able to be configured flexibly, allowing the optimization of the system performance for a given MVDS transmitter bandwidth (see annex C).

The System is suitable for single carrier per MVDS transmitter Time Division Multiplex (TDM) type applications.

The System can also be used for multi-carrier Frequency Division Multiplex (FDM) type applications.

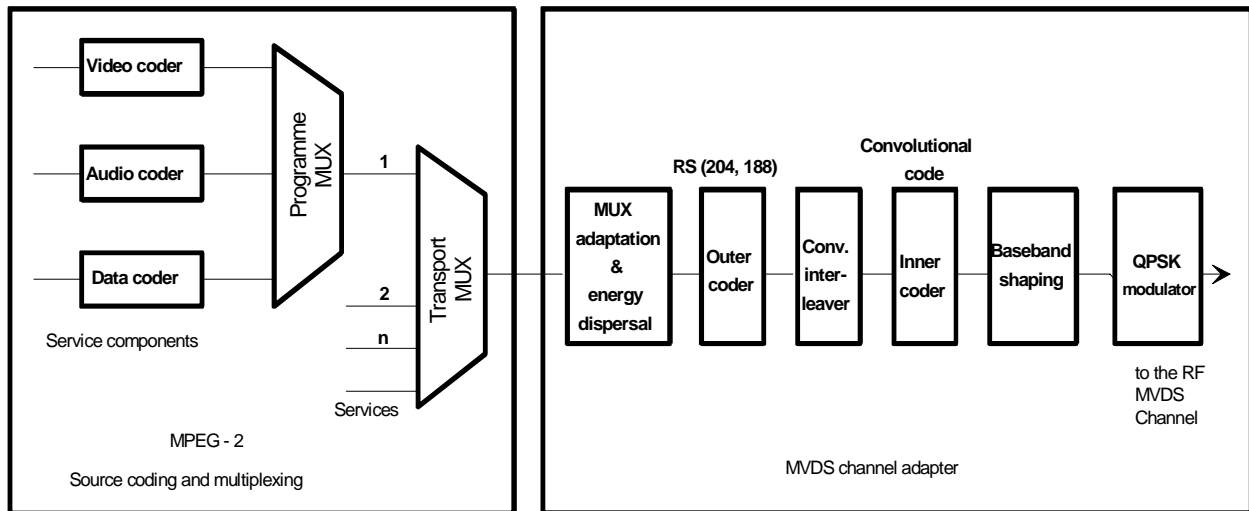

Figure 1: Functional block diagram of the System

The System is directly compatible with MPEG-2 coded TV signals. The modem transmission frame is synchronous with the MPEG-2 multiplex transport packets.

If the received signal is above C/N and C/I threshold, the Forward Error Correction (FEC) technique adopted in the System is designed to provide a Quasi Error Free (QEF) quality target. The QEF means less than one uncorrected error-event per transmission hour, corresponding to Bit Error Ratio (BER) = 10^{-10} to 10^{-11} at the input of the MPEG-2 demultiplexer.

4.2 Adaptation to MVDS transmitter characteristics

MVDS transmitters of digital multi-programme TV services will use channels within band plans set according to individual countries' planning and regulatory criteria and are required to provide compatibility with existing digital cable and satellite services. The MVDS transmitter performance specification and, in particular, its operating bandwidth will determine the data rates available to the service.

The symbol rate shall be matched to given MVDS transmitter characteristics. Examples based on computer simulations for a hypothetical MVDS chain, not including interference effects, are given in annex C.

4.3 Interfacing

The System, as defined in the present document, shall be delimited by the following interfaces given in table 1:

Table 1: System interfaces

Location	Interface	Interface type	Connection
Transmit station	Input	MPEG-2 transport multiplex	from MPEG-2 multiplexer
	Output	70/140 MHz IF	to RF devices
Receive installation	Output	MPEG-2 transport multiplex	to MPEG-2 demultiplexer
	Input	TBD	from RF devices (indoor unit)

4.4 Channel coding

4.4.1 Transport multiplex adaptation and randomization for energy dispersal

The System input stream shall be organized in fixed length packets (see figure 3), following the MPEG-2 transport multiplexer. The total packet length of the MPEG-2 transport Multiplex (MUX) packet is 188 bytes. This includes 1 sync-word byte (i.e. 47_{HEX}). The processing order at the transmitting side shall always start from the MSB (i.e. "0") of the sync word-byte (i.e. 01000111).

In order to comply with ITU Radio Regulations and to ensure adequate binary transitions, the data of the input MPEG-2 multiplex shall be randomized in accordance with the configuration depicted in figure 2.

The polynomial for the Pseudo Random Binary Sequence (PRBS) generator shall be:

$$1 + X^{14} + X^{15} .$$

Loading of the sequence "10010101000000" into the PRBS registers, as indicated in figure 2, shall be initiated at the start of every eight transport packets. To provide an initialization signal for the descrambler, the MPEG-2 sync byte of the first transport packet in a group of eight packets is bit-wise inverted from 47_{HEX} to B8_{HEX}. This process is referred to as the "Transport Multiplex Adaptation".

The first bit at the output of the PRBS generator shall be applied to the first bit (i.e. MSB) of the first byte following the inverted MPEG-2 sync byte (i.e. B8_{HEX}). To aid other synchronization functions, during the MPEG-2 sync bytes of the subsequent 7 transport packets, the PRBS generation shall continue, but its output shall be disabled, leaving these bytes unrandomized. Thus, the period of the PRBS sequence shall be 1 503 bytes.

The randomization process shall be active also when the modulator input bit-stream is non-existent, or when it is non-compliant with the MPEG-2 transport stream format (i.e. 1 sync byte + 187 packet bytes). This is to avoid the emission of an unmodulated carrier from the modulator.

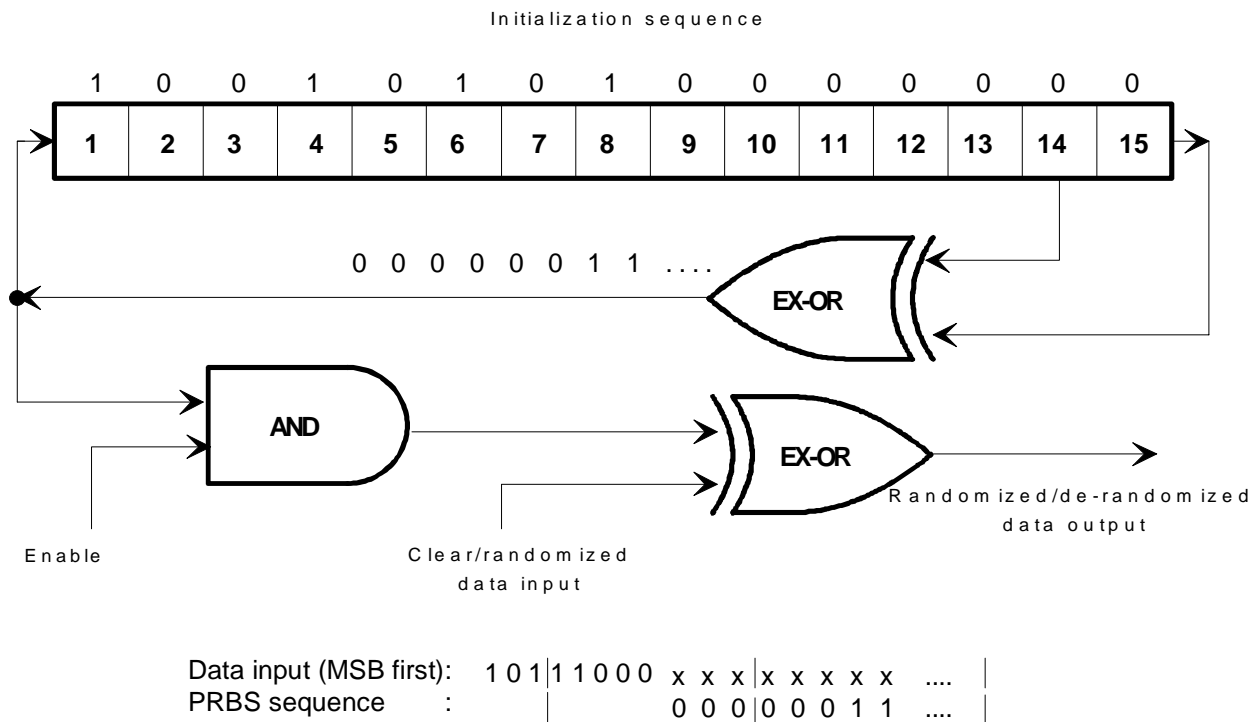

Figure 2: Randomizer/de-randomizer schematic diagram

4.4.2 Outer coding (Reed-Solomon), interleaving and framing

The framing organization shall be based on the input packet structure (see figure 3a).

Reed-Solomon RS(204,188, T = 8) shortened code, from the original RS(255,239, T = 8) code, shall be applied to each randomized transport packet (188 bytes) of figure 3b to generate an error protected packet (see figure 3c).

RS coding shall also be applied to the packet sync byte, either non-inverted (i.e. 47_{HEX}) or inverted (i.e. B8_{HEX}).

Code generator polynomial: $g(x) = (x+\lambda^0)(x+\lambda^1)(x+\lambda^2) \dots(x+\lambda^{15})$, where $\lambda = 02_{\text{HEX}}$.

Field generator polynomial: $p(x) = x^8 + x^4 + x^3 + x^2 + 1$.

The shortened RS code may be implemented by adding 51 bytes, all set to zero, before the information bytes at the input of a (255,239) encoder.

After the RS coding procedure these null bytes shall be discarded.

Following the conceptual scheme of figure 4, convolutional interleaving with depth $I = 12$ shall be applied to the error protected packets (see figure 3c). This results in an interleaved frame (see figure 3d).

The convolutional interleaving process shall be based on the Forney approach [2] which is compatible with the Ramsey type III approach, with $I = 12$.

The interleaved frame shall be composed of overlapping error protected packets and shall be delimited by inverted or non-inverted MPEG-2 sync bytes (preserving the periodicity of 204 bytes).

The interleaver may be composed of $I = 12$ branches, cyclically connected to the input byte-stream by the input switch.

Each branch shall be a First-In, First-Out (FIFO) shift register, with depth $(M j)$ cells (where $M = 17 = N/I$, $N = 204 =$ error protected frame length, $I = 12 =$ interleaving depth, $j =$ branch index).

The cells of the FIFO shall contain 1 byte, and the input and output switches shall be synchronized.

For synchronization purposes, the sync bytes and the inverted sync bytes shall be always routed in the branch "0" of the interleaver (corresponding to a null delay).

NOTE: The de-interleaver is similar, in principle, to the interleaver, but the branch indexes are reversed (i.e. $j = 0$ corresponds to the largest delay).

The de-interleaver synchronization can be carried out by routing the first recognized sync byte in the "0" branch.

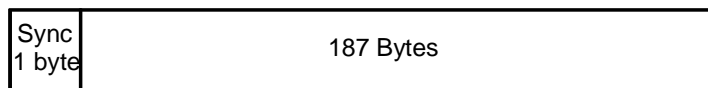

Figure 3a) MPEG-2 transport MUX packet

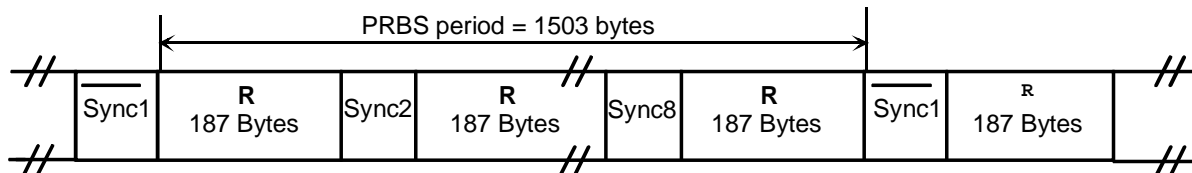

Figure 3b) Randomized transport packets: Sync bytes and randomized sequence R

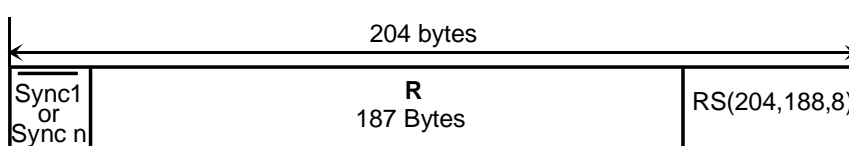

Figure 3c) Reed-Solomon RS (204,188, T=8) error protected packet

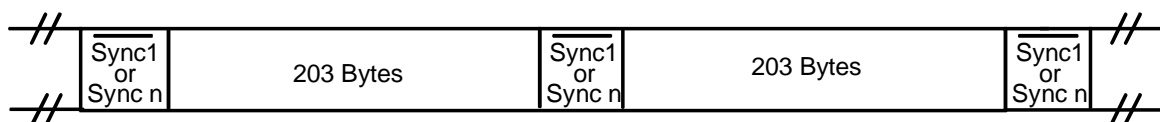

Figure 3d) Interleaved frames; interleaving depth l=12 bytes

Sync1 = not randomized complemented sync byte
 Sync n = not randomized sync byte, n = 2, 3, ..., 8

Figure 3: Framing structure

4.4.3 Inner coding (convolutional)

The System shall allow for a range of punctured convolutional codes, based on a rate 1/2 convolutional code with constraint length $K = 7$.

This will allow selection of the most appropriate level of error correction for a given service or data rate.

The System shall allow convolutional coding with code rates of 1/2, 2/3, 3/4, 5/6 and 7/8.

The punctured convolutional code shall be used as given in table 2. See also figure 5.

NOTE: At the receiver, each of the code rates and puncturing configurations is in a position to be tried until lock is acquired. π phase ambiguity in the demodulator is able to be resolved by decoding the MPEG-2 sync byte delimiting the interleaved frame.

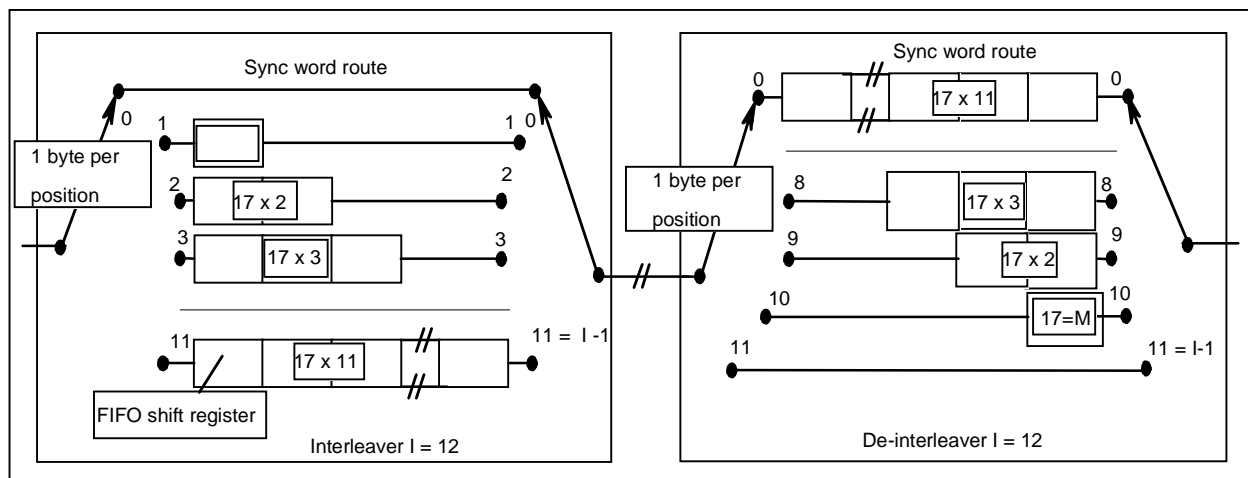

Figure 4: Conceptual diagram of the convolutional interleaver and de-interleaver

Table 2: Punctured code definition

Original code			Code rates									
			1/2		2/3		3/4		5/6		7/8	
K	G ₁ (X)	G ₂ (Y)	P	d _{free}	P	d _{free}	P	d _{free}	P	d _{free}	P	d _{free}
7	171 _{OCT}	133 _{OCT}	X: 1 Y: 1 I = X ₁ Q = Y ₁	10	X: 10 Y: 11 I = X ₁ Y ₂ Y ₃ Q = Y ₁ X ₃ Y ₄	6	X: 101 Y: 110 I = X ₁ Y ₂ Q = Y ₁ X ₃	5	X: 10101 Y: 11010 I = X ₁ Y ₂ Y ₄ Q = Y ₁ X ₃ X ₅	4	X: 1000101 Y: 1111010 I = X ₁ Y ₂ Y ₄ Y ₆ Q = Y ₁ Y ₃ X ₅ X ₇	3
NOTE: 1 = transmitted bit 0 = non-transmitted bit												

4.5 Baseband shaping and modulation

The System shall employ conventional Gray-coded QPSK modulation with absolute mapping (no differential coding). Bit mapping in the signal space as given on figure 5 shall be used.

Prior to modulation, the I and Q signals (mathematically represented by a succession of Dirac delta functions spaced by the symbol duration $T_s = 1/R_s$, with appropriate sign) shall be square root raised cosine filtered.

The roll-off factor α shall be 0,35.

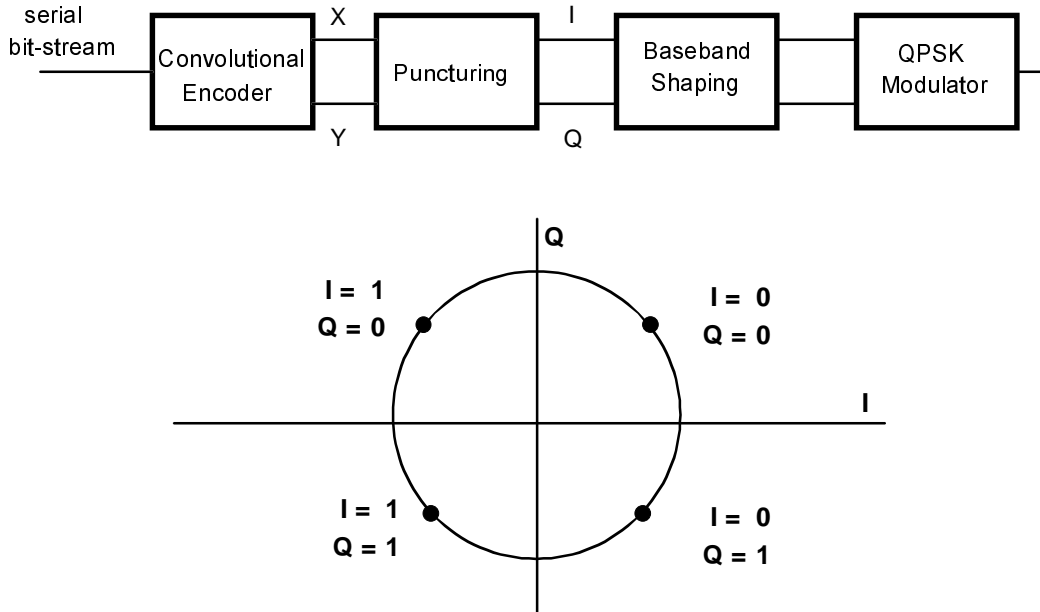

Figure 5: QPSK constellation

The baseband square root raised cosine filter shall have a theoretical function defined by the following expression:

$$H(f) = 1 \text{ for } |\varepsilon| < f_N(1 - \alpha)$$

$$H(f) = \left\{ \frac{1}{2} + \frac{1}{2} \sin \frac{\pi}{2f_N} \left[\frac{f_N - |f|}{\alpha} \right] \right\}^{1/2} \quad \text{for } f_N(1 - \alpha) \leq |f| \leq f_N(1 + \alpha)$$

$$H(f) = 0 \quad \text{for } |\varepsilon| > f_N(1 + \alpha),$$

where

$$f_N = \frac{1}{2T_s} = \frac{R_s}{2} \quad \text{is the Nyquist frequency}$$

and

α is the roll-off factor, $\alpha = 0,35$.

A template for the signal spectrum at the modulator output is given in annex A.

5 Error performance requirements

The modem, connected in the IF loop, shall meet the BER versus E_b/N_o performance requirements given in table 3.

Table 3: IF-loop performance of the System

Inner code rate	Required E_b/N_o for BER = 2×10^{-4} after Viterbi QEF after Reed-Solomon
1/2	4,5
2/3	5,0
3/4	5,5
5/6	6,0
7/8	6,4

NOTE 1: The figures of E_b/N_o refer to the useful bit-rate before RS coding and include a modem implementation margin of 0,8 dB and the noise bandwidth increase due to the outer code ($10 \log 188/204 = 0,36$ dB).

NOTE 2: Quasi-Error-Free (QEF) means less than one uncorrected error event per hour, corresponding to BER = 10^{-10} to 10^{-11} at the input of the MPEG-2 demultiplexer.

Indicative figures of the System performance by MVDS are given in annex D.

Annex A (normative): Signal spectrum at the modulator output

Figure A.1 gives a template for the signal spectrum at the modulator output.

Figure A.1 also represents a possible mask for a hardware implementation of the Nyquist modulator filter as specified in subclause 4.5.

The points A to S shown on figures A.1 and A.2 are defined in table A.1.

The mask for the filter frequency response is based on the assumption of ideal Dirac delta input signals, spaced by the symbol period $T_s = 1/R_s = 1/2f_N$, while in the case of rectangular input signals a suitable $x/\sin x$ correction shall be applied on the filter response.

Figure A.2 gives a mask for the group delay for the hardware implementation of the Nyquist modulator filter.

Figures A.1 and A.2 are based on Intelsat Earth Station Standards (IESS) No. 308 [3], with slight modification due to different roll-off.

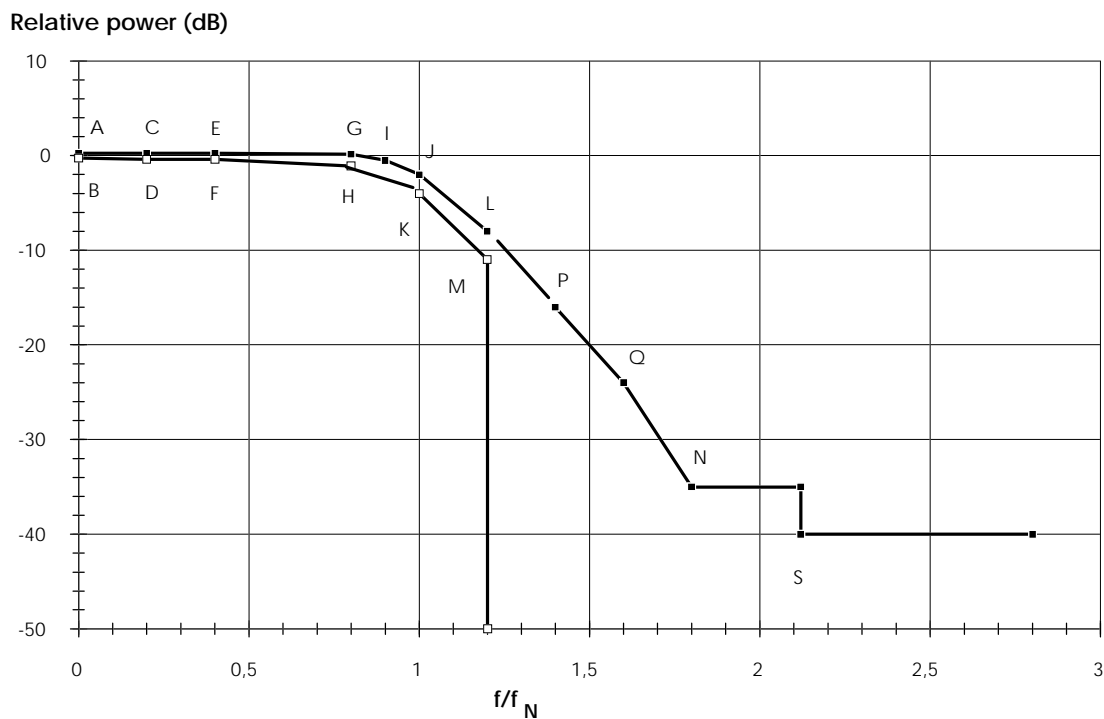

Figure A.1: Template for the signal spectrum mask at the modulator output represented in the baseband frequency domain

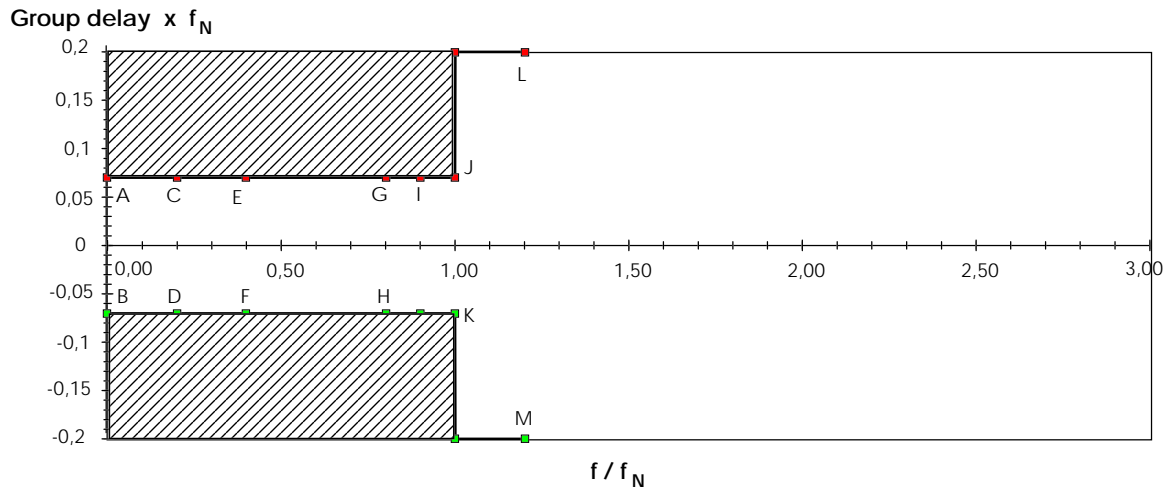

Figure A.2: Template of the modulator filter group delay

Table A.1: Definition of points given in figure A.1

Point	Frequency	Relative power (dB)	Group delay
A	$0,0 f_N$	+0,25	$+0,07 / f_N$
B	$0,0 f_N$	-0,25	$-0,07 / f_N$
C	$0,2 f_N$	+0,25	$+0,07 / f_N$
D	$0,2 f_N$	-0,40	$-0,07 / f_N$
E	$0,4 f_N$	+0,25	$+0,07 / f_N$
F	$0,4 f_N$	-0,40	$-0,07 / f_N$
G	$0,8 f_N$	+0,15	$+0,07 / f_N$
H	$0,8 f_N$	-1,10	$-0,07 / f_N$
I	$0,9 f_N$	-0,50	$+0,07 / f_N$
J	$1,0 f_N$	-2,00	$+0,07 / f_N$
K	$1,0 f_N$	-4,00	$-0,07 / f_N$
L	$1,2 f_N$	-8,00	-
M	$1,2 f_N$	-11,00	-
N	$1,8 f_N$	-35,00	-
P	$1,4 f_N$	-16,00	-
Q	$1,6 f_N$	-24,00	-
S	$2,12 f_N$	-40,00	-

Annex B (informative): Conceptual system description

The modulator and demodulator may perform the functions indicated in the block diagrams of figure B.1.

Due to the similarity of the modulator and demodulator block diagrams, only the latter is described as follows:

- **IF interface and QPSK demodulator:** this unit performs the quadrature coherent demodulation function and the analogue to digital conversion, providing "soft decision" I and Q information to the inner decoder.
- **Matched filter:** this unit performs the complementary pulse shaping filtering of raised cosine type according to the roll-off. The use of a Finite Impulse Response (FIR) digital filter could provide equalization of the channel linear distortions in the IRD.
- **Carrier/clock recovery unit:** this device recovers the demodulator synchronization. The probability of slips generation over the full C/N range of the demodulator should be very low.
- **Inner decoder:** this unit performs first level error protection decoding. It should operate at an input equivalent "hard decision" BER in the order of between 10^{-1} and 10^{-2} (depending on the adopted code rate), and should produce an output BER of about 2×10^{-4} or lower. This output BER corresponds to QEF service after outer code correction. It is possible that this unit makes use of "soft decision" information. This unit is in a position to try each of the code rates and puncturing configurations until lock is acquired. Furthermore, it is in a position to resolve $\pi/2$ demodulation phase ambiguity.

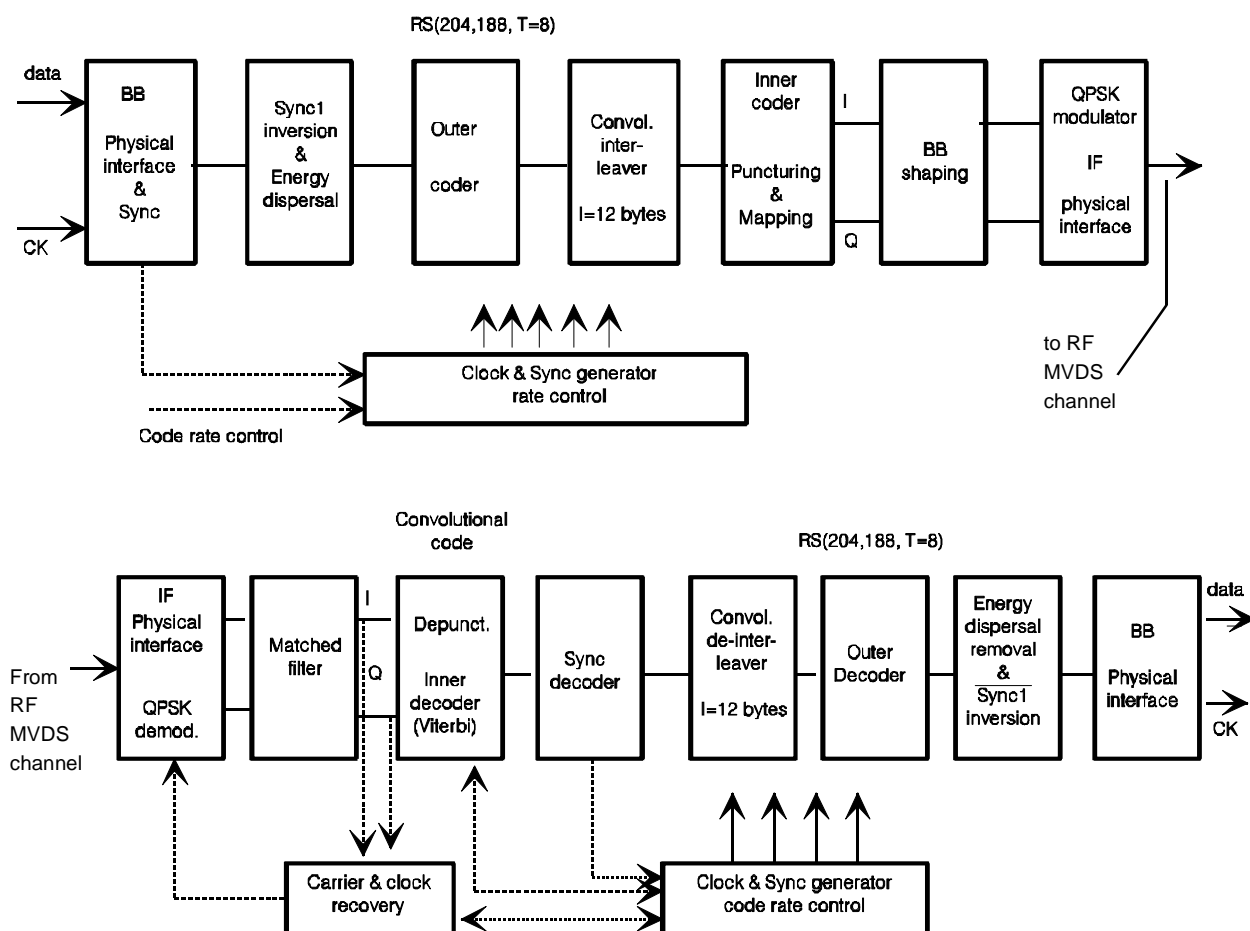

Figure B.1: Conceptual block diagram of the System at the transmitting and receiving side

- **Sync byte decoder:** by decoding the MPEG-2 sync bytes, this decoder provides synchronization information for the de-interleaving. It is also in a position to recover π ambiguity of QPSK demodulator (not detectable by the Viterbi decoder).
- **Convolutional de-interleaver:** this device allows the error bursts at the output of the inner decoder to be randomized on a byte basis in order to improve the burst error correction capability of the outer decoder.
- **Outer decoder:** this unit provides second level error protection. It is in a position to provide QEF output (i.e. BER of about 10^{-10} to 10^{-11}) in the presence of input error bursts at a BER of about 7×10^{-4} or better with infinite byte interleaving. In the case of interleaving depth $I = 12$, $BER = 2 \times 10^{-4}$ is assumed for QEF.
- **Energy dispersal removal:** this unit recovers the user data by removing the randomizing pattern used for energy dispersal purposes and changes the inverted sync byte to its normal MPEG-2 sync byte value.
- **Baseband physical interface:** this unit adapts the data structure to the format and protocol required by the external interface.

NOTE: A possibility is provided by the MPEG-2 system to set on the error flag bit in the packet header if the correction capability of the outer code is exceeded.

Annex C (informative): Examples of bit rates versus MVDS transmitter bandwidth

The transmission symbol rate R_s can be matched to given MVDS transmitter characteristics, to achieve the maximum transmission capacity compatible with the acceptable signal degradation due to MVDS transmitter bandwidth limitations. Table C.1 gives examples of the useful bit rate capacity R_u achievable through a MVDS transmitter with bandwidth BW corresponding to $BW/R_s = 1,28$.

Other BW/R_s values may be adopted for different service requirements, depending on the trade-off between transmission capacity and E_b/N_0 degradation.

At millimetric frequencies, the physical realization of radio frequency channel-defining filters for the output amplifiers of MVDS transmitters becomes very expensive and impracticable. However, the limit on the MVDS transmitter bandwidth will normally be imposed by the spectrum mask defined in the equipment performance specification. Figure C.1 gives an example of a typical spectrum limit mask for a 40 GHz MVDS transmitter with a -3 dB total bandwidth of 33 MHz.

Table C.1: Examples of bit rates versus MVDS transmitter bandwidth

BW at -3 dB (MHz)	BW' at -1 dB (MHz)	R_s (for $BW/R_s = 1,28$) (Mbaud)	R_u (for QPSK + 1/2 convol) (Mbit/s)	R_u (for QPSK + 2/3 convol) (Mbit/s)	R_u (for QPSK + 3/4 convol) (Mbit/s)	R_u (for QPSK + 5/6 convol) (Mbit/s)	R_u (for QPSK + 7/8 convol) (Mbit/s)
54	48,6	42,2	38,9	51,8	58,3	64,8	68,0
46	41,4	35,9	33,1	44,2	49,7	55,2	58,0
40	36,0	31,2	28,8	38,4	43,2	48,0	50,4
36	32,4	28,1	25,9	34,6	38,9	43,2	45,4
33	29,7	25,8	23,8	31,7	35,6	39,6	41,6
30	27,0	23,4	21,6	28,8	32,4	36,0	37,8
27	24,3	21,1	19,4	25,9	29,2	32,4	34,0
26	23,4	20,3	18,7	25,0	28,1	31,2	32,8

NOTE: R_u stands for the useful bit rate after MPEG-2 MUX. R_s (symbol rate) corresponds to the -3 dB bandwidth of the modulated signal.

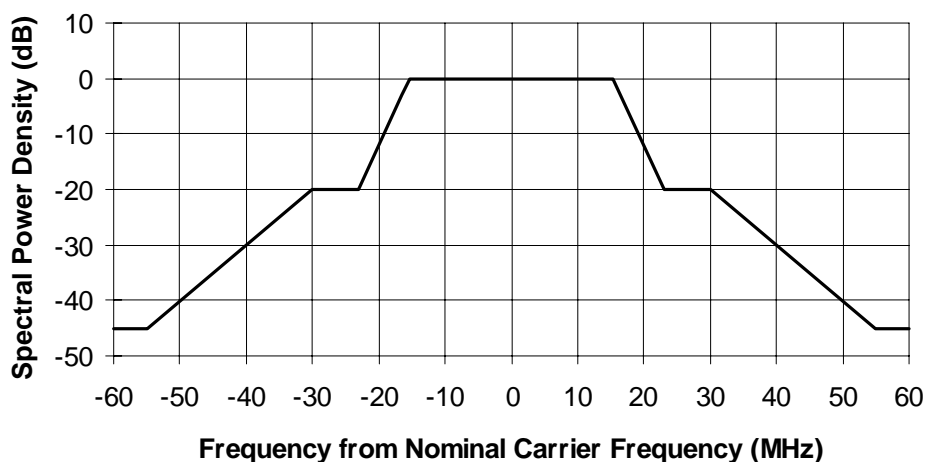

Figure C.1: A typical spectrum limit mask for a 40 GHz MVDS transmitter

Annex D (informative): Examples of possible use of the System

Table D.1 considers possible examples of use of the System for a nominal MVDS transmitter bandwidth (-3 dB) of 33 MHz. Different inner code rates are given with the relevant bit rates.

Figure D.1 shows that the example highlighted in table D.1 with rate 2/3 inner code would be suitable for connection to a PDH terrestrial network at 34,368 Mbit/s, including the same RS error protection used by MVDS.

Table D.1: Example of System performance over 33 MHz MVDS transmitter

Bit rate R_u (after MUX) (Mbit/s)	Bit rate R'_u (after RS) (Mbit/s)	Symbol rate (Mbaud)	Convolutional Inner Code rate	RS Outer Code rate	C/N (33 MHz) (dB)
23,754	25,776	25,776	1/2	188/204	4,1
31,672	34,368	25,776	2/3	188/204	5,8
35,631	38,664	25,776	3/4	188/204	6,8
39,590	42,960	25,776	5/6	188/204	7,8
41,570	45,108	25,776	7/8	188/204	8,4

NOTE 1: The figures in table D.1 refer to computer simulation results achieved on a hypothetical MVDS transmitter chain, conforming to the spectrum mask in figure C.1, with modulation roll-off of 0,35. The C/N figures are based on the assumption of soft-decision Viterbi decoding in the receiver. The ratio $BW/R_s = 1,28$ has been adopted.

NOTE 2: The figures for C/N include a calculated degradation of 0,8 dB non-linear distortion on the MVDS transmitter power amplifier (at saturation) and 0,8 dB modem degradation. The figures apply to $BER = 2 \times 10^{-4}$ before RS(204,188), which corresponds to Quasi Error Free (QEF) at the RS coder output. Degradation due to interference is not taken into account.

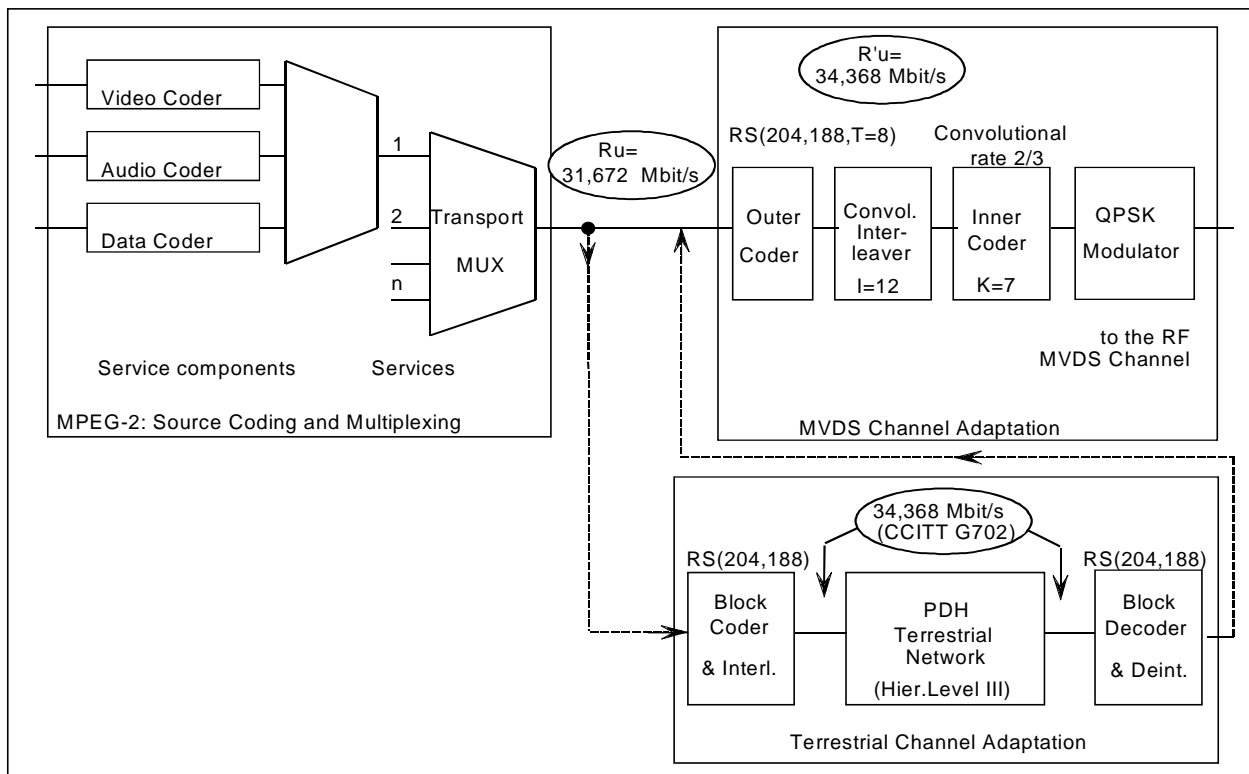

Figure D.1: Example of connection of the System with the terrestrial PDH network

Annex E (informative): Bibliography

For the purposes of the present document, the following informative references apply:

- TVB 1163/GT V4/MOD 269 2nd revised version (November 1993): "Potential applications of the baseline modulation/channel coding system for digital multi-programme television by satellite" (Contribution from V4/MOD).
- Reimers, U. NAB'93, (EBU V4/MOD 249): "The European perspectives on Digital Television Broadcasting".
- Cominetti, M., Morello, A., Visintin, M. EBU Review - Technical, Summer '93, (EBU V4/MOD 235 rev.): "Satellite digital multi-programme TV/HDTV".
- EN 300 421: "Digital Video Broadcasting (DVB); Framing structure, channel coding and modulation for 11/12 GHz satellite services".
- EN 300 429: "Digital Video Broadcasting (DVB); Framing structure, channel coding and modulation for cable systems".

History

Document history		
Edition 1	October 1996	Publication as ETS 300 748
V1.1.2	August 1997	Publication