

Final draft **ETSI EN 300 688** V1.2.1 (2001-02)

European Standard (Telecommunications series)

**Access and Terminals (AT);
140 Mbit/s digital leased lines (D140U and D140S);
Connection characteristics**



Reference

REN/AT-020016

Keywords

access, digital, leased line, ONP

ETSI

650 Route des Lucioles
F-06921 Sophia Antipolis Cedex - FRANCE

Tel.: +33 4 92 94 42 00 Fax: +33 4 93 65 47 16

Siret N° 348 623 562 00017 - NAF 742 C
Association à but non lucratif enregistrée à la
Sous-Préfecture de Grasse (06) N° 7803/88

Important notice

Individual copies of the present document can be downloaded from:

<http://www.etsi.org>

The present document may be made available in more than one electronic version or in print. In any case of existing or perceived difference in contents between such versions, the reference version is the Portable Document Format (PDF). In case of dispute, the reference shall be the printing on ETSI printers of the PDF version kept on a specific network drive within ETSI Secretariat.

Users of the present document should be aware that the document may be subject to revision or change of status. Information on the current status of this and other ETSI documents is available at <http://www.etsi.org/tb/status/>

If you find errors in the present document, send your comment to:
editor@etsi.fr

Copyright Notification

No part may be reproduced except as authorized by written permission.
The copyright and the foregoing restriction extend to reproduction in all media.

© European Telecommunications Standards Institute 2001.
All rights reserved.

Contents

Intellectual Property Rights	5
Foreword.....	5
Introduction.....	5
1 Scope.....	6
2 References.....	6
3 Definitions and abbreviations.....	7
3.1 Definitions.....	7
3.2 Abbreviations.....	8
4 Requirements.....	8
4.1 Attributes.....	9
4.1.1 Transfer rate.....	9
4.1.1.1 Leased line timing.....	9
4.1.1.2 Information transfer rate.....	10
4.1.2 Information transfer susceptance.....	10
4.1.3 Structure.....	10
4.1.3.1 Frame integrity.....	10
4.1.3.2 Loss of input signal.....	10
4.1.4 Symmetry.....	10
4.1.5 Network performance.....	11
4.1.5.1 Transmission delay.....	11
4.1.5.2 Jitter.....	11
4.1.5.2.1 Jitter tolerance at the network input port.....	11
4.1.5.2.2 Maximum jitter at the network output port.....	12
4.1.5.3 Error performance.....	12
4.1.5.3.1 Bringing Into Service (BIS) limits.....	12
4.1.5.3.2 Performance level.....	13
4.1.5.4 Availability.....	13
Annex A (normative): Test methods.....	14
A.1 General.....	14
A.1.1 Equipment connection.....	14
A.2 Test methods.....	15
A.2.1 Leased line timing, information transfer rate, susceptance and symmetry.....	15
A.2.2 Delay.....	16
A.2.3 Jitter.....	17
A.2.4 Error performance.....	19
A.2.5 Structure - frame integrity.....	20
A.2.6 Structure - lack of input signal.....	21
Annex B (normative): Definition of frame structure.....	22
B.1 Frame structure at 139 364 kbit/s.....	22
Annex C (informative): Derivation of error performance limits.....	24
C.1 Introduction.....	24
C.2 Reference connections.....	24
C.2.1 Terrestrial connection.....	24
C.2.2 Satellite connection.....	25

C.3	Error performance objectives	25
C.4	Long term error performance	26
Annex D (informative):	Availability	27
D.1	General.....	27
D.1.1	Unavailability.....	27
D.1.2	Outage intensity	27
D.1.3	Mean time between failures	27
D.1.4	Mean time to restore service	27
D.2	Recommendations	27
Annex E (informative):	Bringing Into Service (BIS) limits	29
E.1	General.....	29
E.2	BIS limits	29
Annex F (informative):	Bibliography.....	30
History		31

Intellectual Property Rights

IPRs essential or potentially essential to the present document may have been declared to ETSI. The information pertaining to these essential IPRs, if any, is publicly available for **ETSI members and non-members**, and can be found in ETSI SR 000 314: "*Intellectual Property Rights (IPRs); Essential, or potentially Essential, IPRs notified to ETSI in respect of ETSI standards*", which is available from the ETSI Secretariat. Latest updates are available on the ETSI Web server (<http://www.etsi.org/ipr>).

Pursuant to the ETSI IPR Policy, no investigation, including IPR searches, has been carried out by ETSI. No guarantee can be given as to the existence of other IPRs not referenced in ETSI SR 000 314 (or the updates on the ETSI Web server) which are, or may be, or may become, essential to the present document.

Foreword

This European Standard (Telecommunications series) has been produced by ETSI Technical Committee Access and Terminals (AT), and is now submitted for the ETSI standards One-step Approval Procedure.

The present document resulted from a mandate from the Commission of the European Community (CEC) to provide standards for support of the Directive on Open Network Provision (ONP) of leased lines (92/44/EEC).

There is one other standard that is directly related to the present document:

EN 300 686: "Access and Terminals (AT); 34 Mbit/s and 140 Mbit/s digital leased lines (D34U, D34S, D140U, D140S); Network interface presentation".

Proposed national transposition dates	
Date of latest announcement of this EN (doa):	3 months after ETSI publication
Date of latest publication of new National Standard or endorsement of this EN (dop/e):	6 months after doa
Date of withdrawal of any conflicting National Standard (dow):	6 months after doa

The present document is based on information from ITU-T Recommendations and ETSI publications; the relevant documents are quoted where appropriate.

Introduction

The Council Directive on the application of ONP to leased lines (92/44/EEC) concerns the harmonization of conditions for open and efficient access to, and use of, the leased lines provided over public telecommunications networks, and the availability throughout the European Union of a minimum set of leased lines with harmonized technical characteristics.

The 140 Mbit/s unstructured and structured leased lines are not part of the minimum set of leased lines under the Directive, however, the present document is being written with the intention that where 140 Mbit/s leased lines are offered, they will be in accordance with these harmonized standards.

Under the Directive 91/263/EEC (see annex F), later replaced by 98/13/EC (see annex F), terminal equipment for connection to these leased lines was required to fulfil certain essential requirements.

The present version of the present document has been produced to introduce some necessary changes.

1 Scope

The present document specifies the technical requirements and conformance tests for connection characteristics of point-to-point 140 Mbit/s digital leased lines. These leased lines operate at:

- 139 264 kbit/s providing an information transmission capability, without restriction on binary content, (D140U); and
- 139 264 kbit/s providing an information transmission capability, without restriction on binary content, of 138 240 kbit/s, (D140S); the remaining 1 024 kbit/s provides an 8 kHz framing structure in accordance with ETS 300 337 (ITU-T Recommendation G.832) (see annex F).

A connection is presented via interfaces at Network Termination Points (NTPs) and includes any equipment that may provide the NTP. Signals between NTPs are subject to impairments during their transfer over the connection. The limits to these impairments are stated in the present document. The present document, together with the companion standard EN 300 686 [1], defining the network interface presentation, describes the technical characteristics of the leased line.

The tests specified in the present document cannot be carried out by the leased line provider while the leased line is in service, i.e. carrying users' traffic. Thus the tests are designed for bringing into and returning into service, although there is no obligation to perform these tests each time a leased line is brought into or returned into service. However, if the connection is structured, the error performance may be monitored by the leased line provider while the line is in service.

The present document is applicable for leased lines, including part time leased lines, for which the establishment or release does not require any protocol exchange or other intervention at the NTP.

The present document specifies the conformance tests for the connection requirements. The present document does not include details concerning the implementation of the tests, nor does it include information on any relevant regulations.

2 References

The following documents contain provisions which, through reference in this text, constitute provisions of the present document.

- References are either specific (identified by date of publication, edition number, version number, etc.) or non-specific.
- For a specific reference, subsequent revisions do not apply.
- For a non-specific reference, the latest version applies.

- [1] ETSI EN 300 686: "Access and Terminals (AT); 34 Mbit/s and 140 Mbit/s digital leased lines (D34U, D34S, D140U, D140S); Network interface presentation".
- [2] ITU-T Recommendation O.151 (1992): "Error performance measuring equipment operating at the primary bit rate and above".
- [3] ITU-T Recommendation O.171 (1997): "Timing jitter measuring equipment for digital systems which are based on the plesiochronous digital hierarchy (PDH)".

3 Definitions and abbreviations

3.1 Definitions

For the purposes of the present document, the following terms and definitions apply:

Background Block Error Ratio (BBER): ratio of errored blocks to total blocks during a fixed measurement interval excluding all blocks during severely errored seconds and while the leased line connection is in the unavailable state

Background Block Error (BBE): errored block not occurring as part of a severely errored second

block: set of consecutive bits equivalent to one frame; each bit belongs to one and only one block. The length of each block corresponds to a period of 125 microseconds

errored block: block in which one or more bits are in error

Errored Second (ES): one-second period with one or more errored blocks

Errored Seconds Ratio (ESR): ratio of errored seconds to total seconds during a fixed measurement interval. The ESR is not evaluated while the leased line connection is in the unavailable state

frame: repetitive set of consecutive bits in which the position of each bit can be identified by reference to a frame alignment signal

frame alignment signal: distinctive signal inserted in every frame always occupying the same relative position within the frame and used to establish and maintain frame alignment

leased lines: telecommunications facilities provided by a public telecommunications network that provide defined transmission characteristics between network termination points and that do not include switching functions that the user can control (e.g. on-demand switching)

Network Termination Point (NTP): all physical connections and their technical access specifications which form part of the public telecommunications network and are necessary for access to and efficient communication through that public network

PRBS(2²³-1): Pseudo Random Bit Sequence (PRBS) (as defined in clause 2.2 of ITU-T Recommendation O.151 [2])

satellite transmission: transmission via an earth orbiting satellite

severely disturbed period: for out-of-service measurements, a severely disturbed period occurs when, over a period of time equivalent to four contiguous blocks, either all the contiguous blocks are affected by a high bit error density of $\geq 10^{-2}$, or a loss of signal is observed. For in-service monitoring purposes, a severely disturbed period is estimated by the occurrence of loss of signal or loss of frame alignment

Severely Errored Second (SES): one-second period which contains ≥ 30 % errored blocks or at least one severely disturbed period

Severely Errored Seconds Ratio (SESR): ratio of severely errored seconds to total seconds during a fixed measurement interval. The SESR is not evaluated while the leased line connection is in the unavailable state

unavailability period: unavailability period begins at the onset of 10 consecutive SES. These 10 seconds are considered to be part of the unavailability period. The unavailability period ends at the onset of 10 consecutive non-severely errored seconds. These 10 seconds are not considered part of the unavailability period

unavailable state: leased line connection is in the unavailable state if an unavailability period is occurring in one or both directions of transmission

3.2 Abbreviations

For the purposes of the present document, the following abbreviations apply:

AIS	Alarm Indication Signal
BBE	Background Block Error
BBER	Background Block Error Ratio
BIP-8	Bit Interleaved Parity (8 bit)
BIS	Bringing Into Service
CMI	Coded Mark Inversion
D140U	140 Mbit/s digital unstructured leased line
D140S	140 Mbit/s digital structured leased line
EM	Error Monitoring
EMC	ElectroMagnetic Compatibility
ES	Errored Second
ESR	Errored Seconds Ratio
FA1	Frame Alignment byte 1
FA2	Frame Alignment byte 2
GC	General purpose Communications channel
LSB	Least Significant Bit
MA	Maintenance and Adaptation
MSB	Most Significant Bit
NR	Network operator byte
NTP	Network Termination Point
ONP	Open Network Provision
ppm	parts per million
PRBS	Pseudo Random Bit Sequence
RDI	Remote Defect Indication
REI	Remote Error Indication
RPO	Reference Performance Objective
RX	RX is a signal input (at either the leased line interface or the test equipment)
SES	Severely Errored Second
SESR	Severely Errored Seconds Ratio
TM	Timing Marker
TR	TRail trace
TX	TX is a signal output (at either the leased line interface or the test equipment)
UI	Unit Interval

4 Requirements

The performance of the leased line shall comply with these requirements only if the conditions of supply of the network equipment providing the NTP are met, (e.g. if the equipment is connected to an appropriate power supply on the customer's premises).

The ITU-T attribute technique is used to express the connection requirements. The following attributes from ITU-T Recommendation I.140 (see annex F) are specified in the present document:

- transfer rate;
- information transfer susceptance;
- structure;
- establishment of connection;
- symmetry;
- connection configuration;
- network performance.

The following network performance sub-attributes are considered relevant for the present document:

- transmission delay;
- jitter;
- error;
- availability.

4.1 Attributes

The connection attributes are displayed in table 1. In effect, these attributes define the service being offered.

The values and the associated compliance tests can be found in the subsequent clauses.

Table 1: Connection attributes

Connection type attributes	D140U	D140S
	Value / nature	
Transfer rate - leased line timing - information transfer rate	139 264 kbit/s \pm 15 ppm 139 264 kbit/s \pm 15 ppm	139 264 kbit/s \pm 15 ppm 138 240 kbit/s \pm 15 ppm
Information transfer susceptance	Unrestricted digital	
Structure	Unstructured	Frame integrity
Establishment of connection	Without user intervention	
Symmetry	Symmetrical in both directions	
Connection configuration	Point-to-point	
Transmission delay - terrestrial (for distance G in km) - satellite	$\leq (10 + 0,01 G)$ ms ≤ 350 ms	
Jitter at input port	0,4 UI from 200 Hz to 500 Hz 0,075 UI from 10 kHz to 3 500 kHz	
Jitter at output port	1,4 UI from 200 Hz to 3 500 Hz 0,07 UI from 10 kHz to 3 500 Hz	
Availability	No requirement	
Error parameters	D140U and D140S	
	Terrestrial	Satellite
End-to-end performance objectives - Errored Seconds Ratio (ESR) - Severely Errored Seconds Ratio (SESR) - Background Block Error Ratio (BBER)	$\leq 8,00$ % $\leq 0,10$ % $\leq 0,01$ %	$\leq 12,480$ % $\leq 0,156$ % $\leq 0,016$ %
Performance levels over a 24 hour period - Errored Seconds (ES) - Severely Errored Seconds (SES) - Background Block Errors (BBE)	$\leq 6\ 746$ ≤ 68 $\leq 68\ 594$	$\leq 10\ 575$ ≤ 112 $\leq 107\ 170$

4.1.1 Transfer rate

4.1.1.1 Leased line timing

Requirement: The leased line shall be capable of carrying user timing within the range of 139 264 kbit/s \pm 15 ppm.

The leased line provider may also offer to the user in certain installations the capability for the leased line to be synchronized to network timing.

NOTE: Network timing is timing that is derived from the source or sources of timing that are used for the network (i.e. a national primary reference clock). Thus the timing provided by the leased line will be similar to that provided by other digital services.

Test: The test shall be conducted according to clause A.2.1.

4.1.1.2 Information transfer rate

Requirement: The connection shall be capable of transferring a nominal information rate, defined in table 2.

Table 2: Information transfer rate

	D140U	D140S
Information transfer rate	139 264 kbit/s \pm 15 ppm	138 240 kbit/s \pm 15 ppm

Test: The test shall be conducted according to clause A.2.1.

4.1.2 Information transfer susceptibility

Requirement: The connection shall be capable of transferring unrestricted digital information with bit sequence integrity at the nominal rate, defined in table 3.

Table 3: Information transfer susceptibility

	D140U	D140S
Information transfer susceptibility	139 264 kbit/s \pm 15 ppm	138 240 kbit/s \pm 15 ppm

Test: The test shall be conducted according to clause A.2.1.

4.1.3 Structure

4.1.3.1 Frame integrity

The requirement of this clause applies only to the D140S structured leased line.

Requirement: When a signal with the structure defined in annex B is applied to the input of the D140S leased line, the output signal at the far end shall also conform to the structure defined in annex B and the frame alignment byte (FA1 and FA2) shall be in the same position in relation to the contents of the payload.

Test: The test shall be conducted according to clause A.2.5.

4.1.3.2 Loss of input signal

Requirement: When there is no input signal to the leased line, the output signal at the far end of the leased line shall be Alarm Indication Signal (AIS) (all ones).

Test: The test shall be conducted according to clause A.2.6.

4.1.4 Symmetry

Requirement: The connection shall be symmetrical, i.e. each direction of transmission shall have the same information transfer capability (D140U and D140S) and the same frame structure (D140S).

Test: The test shall be conducted according to clause A.2.1.

4.1.5 Network performance

The network performance sub-attributes are displayed in table 1. The values and the associated compliance tests can be found in the subsequent clauses.

4.1.5.1 Transmission delay

Requirement: The requirement depends upon whether satellite transmission is involved in the connection or not:

- a) for connections where satellite transmission is not involved, the one way end-to-end delay shall be less than or equal to $(10 + 0,01 G)$ ms, where G is the geographical distance in kilometres, as shown in figure 1; or

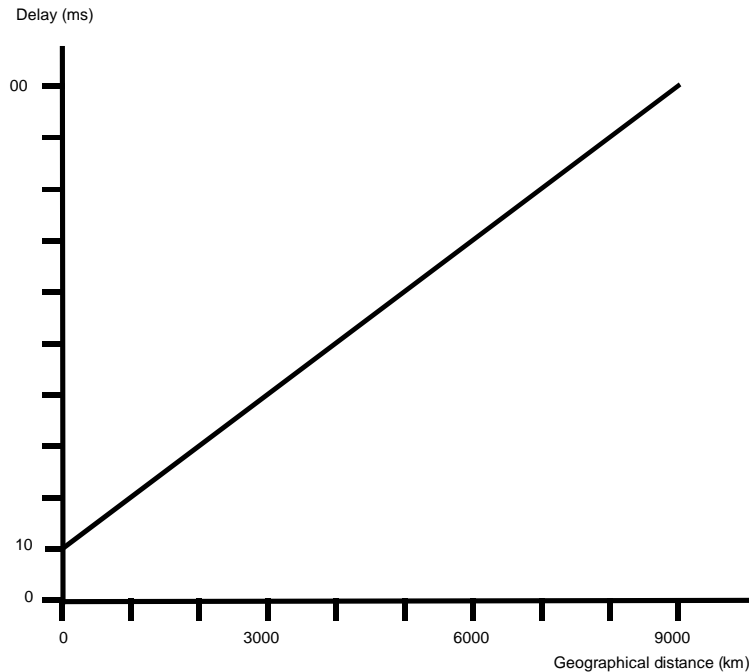

Figure 1: Upper limit of delay

- b) for connections where satellite transmission is involved, the one way end-to-end delay shall be less than or equal to 350 ms.

NOTE: Requirements a) and b) are based on ITU-T Recommendation G.114, clauses A.2 and A.3 (see annex F).

There are no requirements for low frequency (below 20 Hz) variation of one way end-to-end delay under the present document.

Test: The test shall be conducted according to clause A.2.2.

4.1.5.2 Jitter

4.1.5.2.1 Jitter tolerance at the network input port

Requirement: The leased line shall function as specified with input jitter being the sum of the band limited components defined in table 4.

NOTE: The jitter tolerance for the connection is defined in this way instead of specifying single jitter frequencies, for the following reasons:

- this method is more representative of the jitter encountered in practice; and
- long regenerator chains may be especially sensitive to single jitter frequencies.

Table 4: Components of input jitter

Filters for generation of jitter spectrum (first order)		Bandpass filter for measurement of input jitter	Input jitter measured by bandpass filter
Lower cut-off (high pass)	Upper cut-off (low pass)	(lower cut-off first order)	Unit Interval (UI) peak-to-peak (maximum)
200 Hz	500 Hz	200 Hz to 3 500 kHz	0,4
10 kHz	3 500 kHz	10 kHz to 3 500 kHz	0,075

Test: The test shall be conducted according to clause A.2.3.

4.1.5.2.2 Maximum jitter at the network output port

Requirement: The maximum jitter at the output port of the network shall not exceed the limits specified in table 5, based on ITU-T Recommendation G.823 (see annex F), when measured with linear filters with the defined cut-off frequencies.

At frequencies below the lower 3 dB point, the attenuation of the high pass filter shall rise with a value greater than, or equal to, 20 dB per decade. At frequencies above the upper 3 dB point, the attenuation of the low pass filtration shall rise with a value greater than, or equal to, 60 dB per decade.

For the measurement, the maximum input jitter as specified in clause 4.1.5.2.1 shall be applied.

Table 5: Maximum network output jitter

Measurement filter bandwidth		Output jitter
Lower cut-off (high pass)	Upper cut-off (low pass)	UI peak-to-peak (maximum)
200 Hz	3 500 kHz	1,4
10 kHz	3 500 kHz	0,07

Test: The test shall be conducted according to clause A.2.3.

4.1.5.3 Error performance

Errored seconds, severely errored seconds and background block errors shall be excluded from the measurement of the error performance if the leased line is in the unavailable state.

NOTE: When microwave links are used in the connection it may not be possible to meet the requirement in rare periods with very adverse propagation conditions.

The end-to-end error performance rates for a 140 Mbit/s digital leased line using terrestrial or satellite connections are shown in table 6. These are based on the reference connections shown in annex C derived from ITU-T Recommendation G.826 (see annex F) and are valid for block sizes of 6 000 to 20 000 bits.

Table 6: End to end error performance objectives for a 140 Mbit/s digital leased line

Performance parameter	Terrestrial	Satellite
ESR	8,00 %	12,480 %
SESR	0,10 %	0,156 %
BBER	0,01 %	0,016 %

These figures for the error performance are used in the derivation of the performance levels given in clause 4.1.5.3.2. The derivation of these figures is given in annex C.

4.1.5.3.1 Bringing Into Service (BIS) limits

There is no requirement on BIS limits under the present document.

NOTE: Annex E provides guidelines on 24 hour and 2 hour BIS limits.

4.1.5.3.2 Performance level

The performance level of an unstructured leased line in service (i.e. carrying user data) cannot be estimated by the leased line provider since no bit pattern sequence is known. To determine the performance level the leased line needs to be taken out of service (the user will not have any access to the leased line or any service provided during the measurement period). The user may also measure the error performance of the leased line by connecting test equipment to the leased line or by using a proprietary performance calculation facility of the terminal equipment.

The performance level of a structured leased line in service (i.e. carrying user data) can be estimated from the Bit Interleaved Parity - 8 (BIP-8). In order for the leased line provider to perform an accurate error measurement, the leased line may need to be taken out of service (the user will not have any access to the leased line or any service provided during the measuring period). If a leased line provider uses tandem connection monitoring, the binary content of the Error Monitoring (EM) and Network operator (NR) bytes may change but the parity information of the BIP-8 is retained. If the EM byte which contains the BIP-8 information is not generated correctly by the terminal equipment, the performance monitoring of the leased line may give incorrect results.

Requirement: The performance of a leased line either in service or taken out of service in order to perform an error performance measurement, shall meet the requirements given in table 7.

Table 7: Performance levels over 24 hour period for a block length of 17 408 bits

Parameter	Terrestrial	Satellite
ES	≤ 6 746	≤ 10 575
SES	≤ 68	≤ 112
BBE	≤ 68 594	≤ 107 170

Test: The test shall be conducted according to clause A.2.4.

4.1.5.4 Availability

There is no requirement on availability under the present document.

NOTE 1: Annex D provides guidelines on an approach to the specification of availability values.

NOTE 2: At present some leased line providers include availability performance, defined on an individual basis as a quality of service parameter, as part of the contracted supply conditions for their leased line offerings.

Annex A (normative): Test methods

A.1 General

This annex describes the test principles to determine the compliance of a connection against the requirements of the present document.

It is outside the scope of this annex to identify the specific details of the implementation of the tests.

Details of test equipment accuracy and the specification tolerance of the test devices are not included in all cases. Where such details are provided they shall be complied with, but the way they are expressed shall not constrain the method of implementing the test.

NOTE: Attention is drawn to the issue of measurement uncertainty which may be addressed in future documents. Not all the required test results make allowance for spurious events during testing (e.g. errors due to EMC effects), which may make it necessary to repeat a test.

The test configurations given do not imply a specific realization of the test equipment or test arrangement, or the use of specific test devices. However, any test configuration used shall provide those test conditions specified under "connection state", "stimulus" and "monitor" for each individual test.

The test equipment shall be a device, or group of devices that is capable of generating a stimulus signal conforming to EN 300 686 [1] and capable of monitoring the signal received from the network interface.

A.1.1 Equipment connection

Testing shall be performed at the defined NTP as this is the point at which compliance with the present document is required.

A.2 Test methods

One test may cover more than one requirement. The scope of each test is defined under the heading "purpose".

A.2.1 Leased line timing, information transfer rate, susceptance and symmetry

Purpose: To verify compliance with the requirements for leased line timing (clause 4.1.1.1), information transfer rate (clause 4.1.1.2), susceptance (clause 4.1.2) and symmetry (clause 4.1.4).

Test configuration: Test equipment shall be connected to the leased line as shown in figure A.1. The leased line shall be looped back at the far end by a test equipment capable of reducing jitter to the levels specified in the present document.

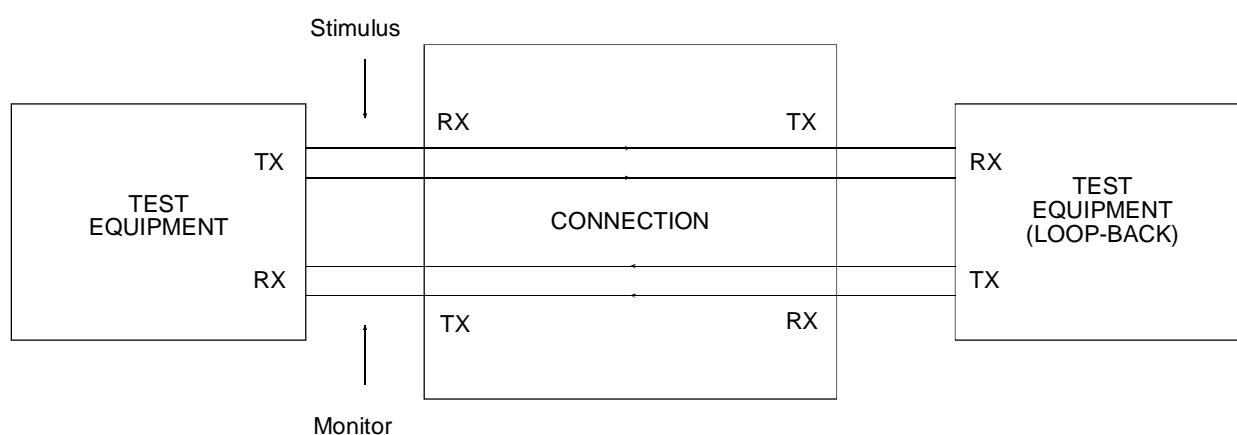

Figure A.1: Leased line timing, information transfer rate, susceptance and symmetry

Connection State: Available.

Stimulus: The test equipment shall generate an encoded bit stream as defined in table A.1. For D140U leased lines the three bit sequences specified in table A.1 shall be transmitted in the whole bit stream. For D140S leased lines the three bit sequences specified in table A.1 shall be transmitted in the payload section of the frame. The tests shall be performed at the bit rate limits given in table A.1.

Table A.1: Test equipment output signal

	D140U	D140S
Encoding	CMI	
Waveform shape	See EN 300 686 [1]	
Frame structure	Unstructured	See annex B
Bit pattern	a) PRBS($2^{23}-1$) b) A sequence of continuous successive binary ZEROs c) A sequence of continuous successive binary ONES	
Bit rate limits	139 364 kbit/s \pm 15 ppm	

Monitor: The bit stream at the output of the leased line.

Results: For each signal a, b and c, for a continuous period of at least one second no alterations to the binary content shall occur.

For signal a on the D140S leased line, the integrity of the frame structure shall be maintained, (i.e. where the payload contains a given sequence at the input of the leased line, the identical sequence shall be contained in the payload at the output of the leased line).

A.2.2 Delay

Purpose: To verify compliance with the requirements for one way transmission delay as specified in clause 4.1.5.1.

Test configuration: Test equipment shall be connected to the leased line as shown in figure A.2. The leased line shall be looped back at the far end by a test equipment capable of reducing jitter to the levels specified in the present document.

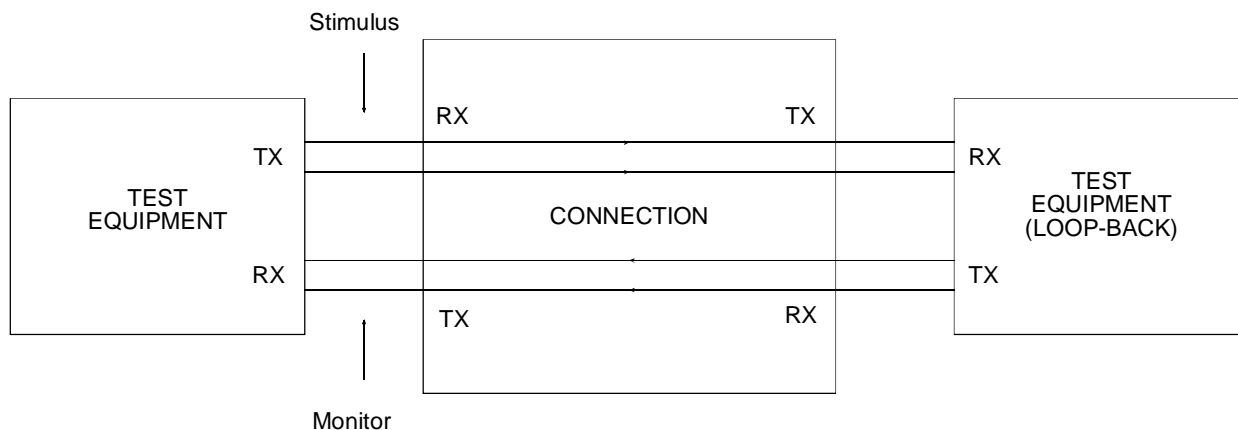

Figure A.2: Delay

Connection State: Available.

Stimulus: The test equipment shall generate an encoded bit stream as defined in table A.2. For D140U leased lines the bit pattern specified in table A.2 shall be transmitted in the whole bit stream. For D140S leased lines the bit pattern specified in table A.2 shall be transmitted in the payload section of the frame. The tests shall be performed at a bit rate within the bit rate limits given in table A.2.

Table A.2: Test equipment output signal

	D140U	D140S
Encoding	CMI	
Waveform shape	See EN 300 686 [1]	
Frame structure	Unstructured	See annex B
Bit pattern	A distinctive bit pattern whose repetition period is greater than the round trip delay	
Bit rate limits	139 364 kbit/s \pm 15 ppm	

Monitor: The round trip delay between transmission and reception of the distinctive bit pattern.

Results: The round trip delay after deduction of the delay introduced by the loop-back test equipment, shall be less than or equal to twice the delay specified in the requirement of clause 4.1.5.1.

NOTE: This test assumes that the same transmission path is used in both directions. It is not practicable to provide a test of the transmission delay in each individual direction.

A.2.3 Jitter

Purpose: To verify compliance with the requirements for jitter tolerance at the network input port as specified in clause 4.1.5.2.1 and for the maximum jitter allowed at the network output port as specified in clause 4.1.5.2.2.

NOTE: Further information on the measurement of jitter can be found in ITU-T Supplement number 3.8 (see annex F).

Test configuration: Test equipment shall be connected to both ends of the leased line, (see figure A.3). Each direction shall be tested separately.

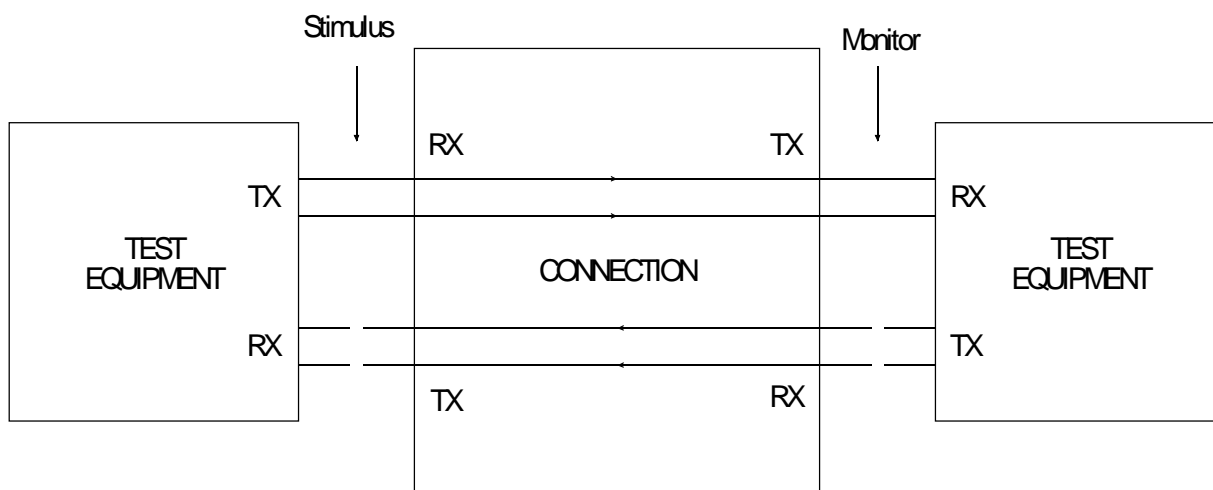

Figure A.3: Jitter

Connection State: Available.

Stimulus: The test equipment shall generate an encoded bit stream as defined in table A.3; this bit stream shall be applied to the input of the connection. For D140U leased lines bit pattern specified in table A.3 should be transmitted in the whole bit stream. For D140S leased lines the bit pattern specified in table A.3 shall be transmitted in the payload section of the frame. The tests shall be performed at the bit rate limits defined in table A.3.

Table A.3: Test equipment output signal

	D140U	D140S
Encoding	CMI	
Waveform shape	See EN 300 686 [1]	
Frame structure	Unstructured	See annex B
Bit pattern	PRBS($2^{23}-1$)	
Bit rate limits	139 364 kbit/s \pm 15 ppm	

Jitter is applied to the input bit stream, where jitter is produced by a voltage controlled jitter modulator, (see figure A.4), modulated by a signal which consists of the following two signals added together:

- a square wave signal produced by a PRBS($2^{23}-1$) bit stream generated at a frequency of 1 000 kHz. The square wave signal shall be filtered by a first order linear band pass filter with the cut off frequencies of 200 Hz and 500 Hz. The voltage amplitude of the square wave pulses shall be constant and of a value that results in measured jitter of 0,4 UI in the bandwidth of 200 Hz to 3 500 kHz;

- b) a square wave signal produced by a PRBS($2^{23}-1$) bit stream generated at a frequency of 1 000 kHz. The square wave signal shall be filtered by a first order linear band pass filter with the cut off frequencies of 10 kHz and 3 500 kHz. The voltage amplitude of the square wave pulses shall be constant and of a value that results in measured jitter of 0,075 UI in the bandwidth of 10 kHz to 3 500 kHz.

NOTE: The filter gains to determine the jitter levels are set individually. Filter FA is used when setting the value of A, with signal B disconnected. Filter FB is used when setting the value of B, with signal A disconnected.

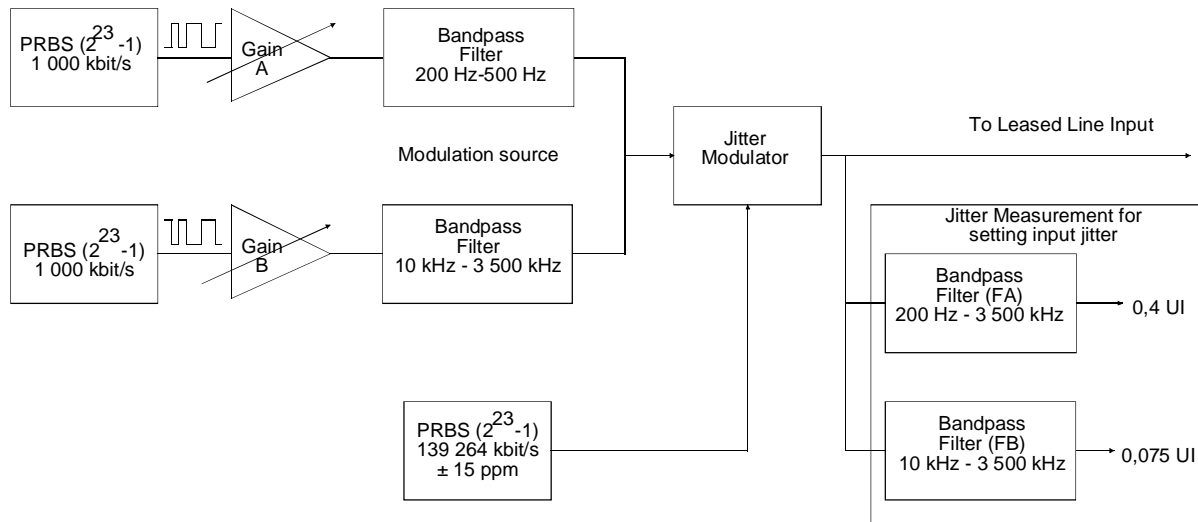

Figure A.4: Jitter testing

Monitor:

- the jitter extracted from the signal at the network output port using equipment complying with ITU-T Recommendation O.171 [3]; and
- the bit stream extracted from the signal at the network output port;

Result:

- the peak to peak jitter at the connection output port shall comply with clause 4.1.5.2.2, table 5; and
- for at least one period out of 10 periods of 10 seconds each, no alterations to the binary content shall occur.

A.2.4 Error performance

Purpose: To verify compliance with the requirements for error as specified in clause 4.1.5.3.

Test configuration: Test equipment shall be connected to both ends of the leased line (see figure A.5). Each direction shall be tested separately.

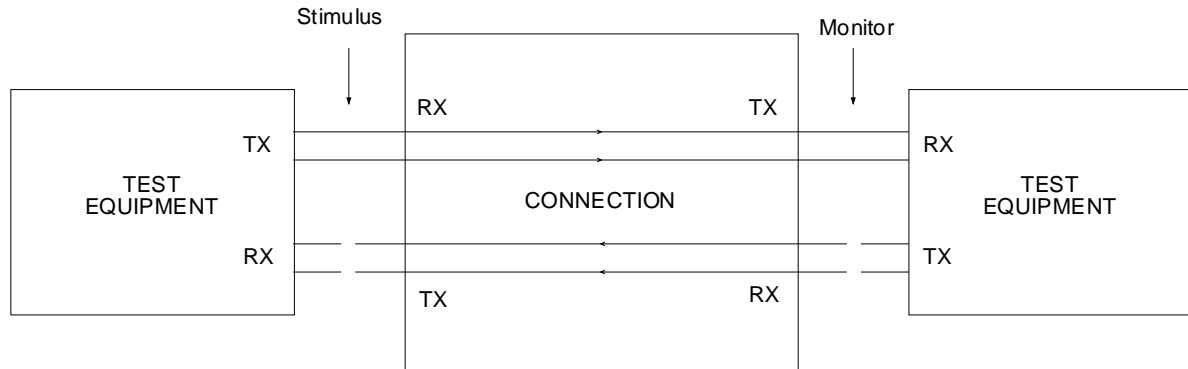

Figure A.5: Error and slip

Connection state: Available.

Stimulus: The test equipment shall generate an encoded bit stream as defined in table A.4; this bit stream shall be applied to the input of the connection and shall be transmitted for two consecutive periods of 24 hours, with jitter modulated and filtered as described by clause 4.1.5.2.1. For D140U leased lines the bit pattern specified in table A.4 shall be transmitted in the whole bit stream. For D140S leased lines the bit pattern specified in table A.4 shall be transmitted in the payload section of the frame.

The tests shall be performed at each of the bit rate limits defined in table A.4 for alternate 12 hour periods.

Table A.4: Test equipment output signal

	D140U	D140S
Encoding	CMI	
Waveform shape	See EN 300 686 [1]	
Frame structure	Unstructured	See annex B
Block length	2 176 x 8 bits	2 176 bytes
Bit pattern	PRBS($2^{23}-1$)	
Bit rate limits	139 364 kbit/s \pm 15 ppm	

Monitor:

- the number of errored seconds;
- the number of severely errored seconds;
- the number of background block errors.

Results: When monitoring a line that is in service, or when monitoring a line that has been taken out of service to perform a measurement, the number of errors, severely errored seconds and background block errors shall be less than the performance level levels given in clause 4.1.5.3.2.

NOTE: If the requirements are met during the first continuous period of 24 hours, the test need not be continued for the second period of 24 hours.

A.2.5 Structure - frame integrity

Purpose: To verify compliance with the requirements for leased line structure as defined in clause 4.1.3. The test verifies the occurrence of the frame alignment signals (FA1 and FA2) at the output of the leased line and that the BIP-8, trail trace, MA byte (RDI, REI, payload type, payload dependent and TM) and general purpose communications channel are carried transparently end-to-end.

Test configuration: Test equipment shall be connected to both ends of the leased line (see figure A.6). Each direction of transmission shall be tested separately.

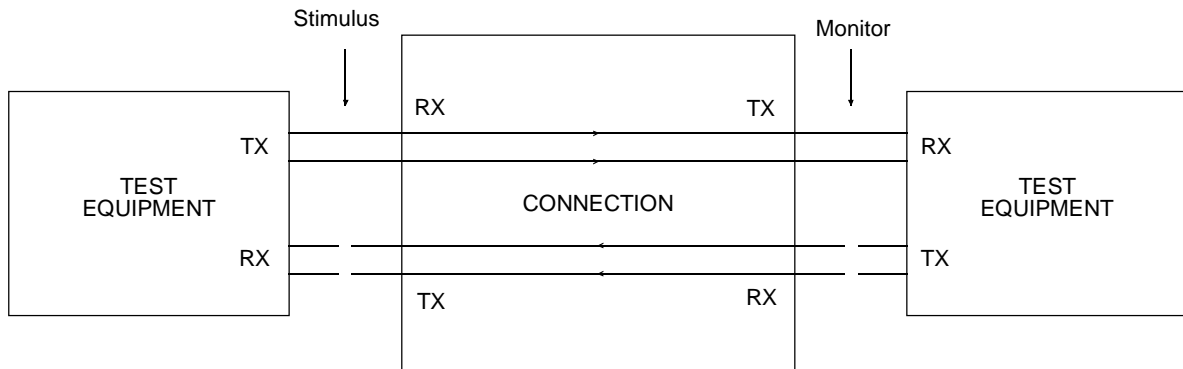

Figure A.6: Structure

Connection State: Available.

Stimulus: The test equipment shall generate an encoded bit stream as defined in table A.5. The tests shall be performed at the bit rate limits given in table A.5.

Table A.5: Test equipment output signal

	D140S
Encoding	CMI
Waveform shape	See EN 300 686 [1]
Frame structure	See annex B (see notes 1 and 2)
Payload	PRBS($2^{23}-1$)
Bit rate limits	139 364 kbit/s \pm 15 ppm
NOTE 1: The TR byte shall be set to the value specified by the leased line provider.	
NOTE 2: Bits 3 to 7 of MA shall be set to 0. Bit 8 of MA shall be tested at 0 and 1.	

Monitor: The bit stream at the far end output of the leased line.

Results: The BIP-8 contained in the EM byte shall correspond to the previous frame.

The trail trace bytes at the output from the leased line shall be equal to the trail trace bytes at the input to the leased line.

The MA byte (RDI, REI, payload type, payload dependent and TM) shall be equal to the equivalent byte at the input to the leased line.

The data contained within the general purpose communications channel shall be equal to the equivalent bytes at the input to the leased line.

A.2.6 Structure - lack of input signal

Purpose: This test verifies that when there is no input signal to the leased line, an AIS (all ones) signal is transmitted at the far end output, as defined in clause 4.1.3.2.

Test configuration: Test equipment shall be connected to the far end of the leased line (see figure A.7). Each direction of transmission shall be tested separately.

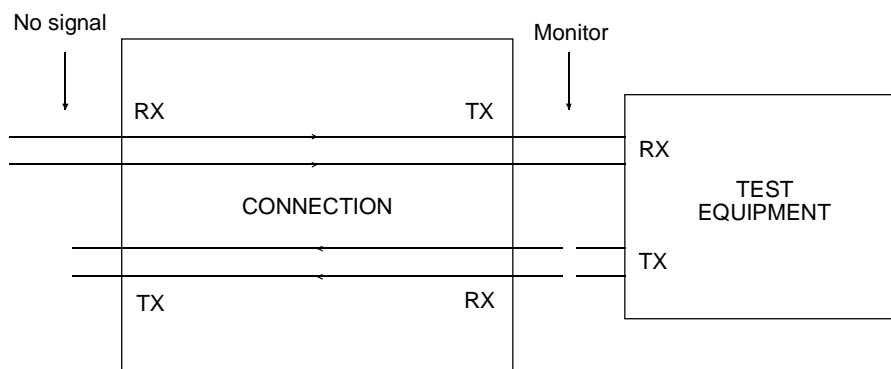

Figure A.7: Structure

Connection State: Available.

Stimulus: There shall be no input signal applied to the leased line input (i.e. the input to the leased line shall be left unconnected).

Monitor: The bit stream at the output of the leased line.

Results: The output bit stream shall be an AIS (all ones) signal.

Annex B (normative): Definition of frame structure

B.1 Frame structure at 139 364 kbit/s

The basic frame structure at 139 264 kbit/s for the D140S leased line comprises 16 octets of generic path overhead and 2 160 octets of payload capacity; this is defined in figures B.1 and B.2. The order of transmission of information in figure B.1 is first from left to right and then top to bottom. Within each byte the most significant bit is transmitted first. The most significant bit (bit 1) is illustrated at the left of figure B.2.

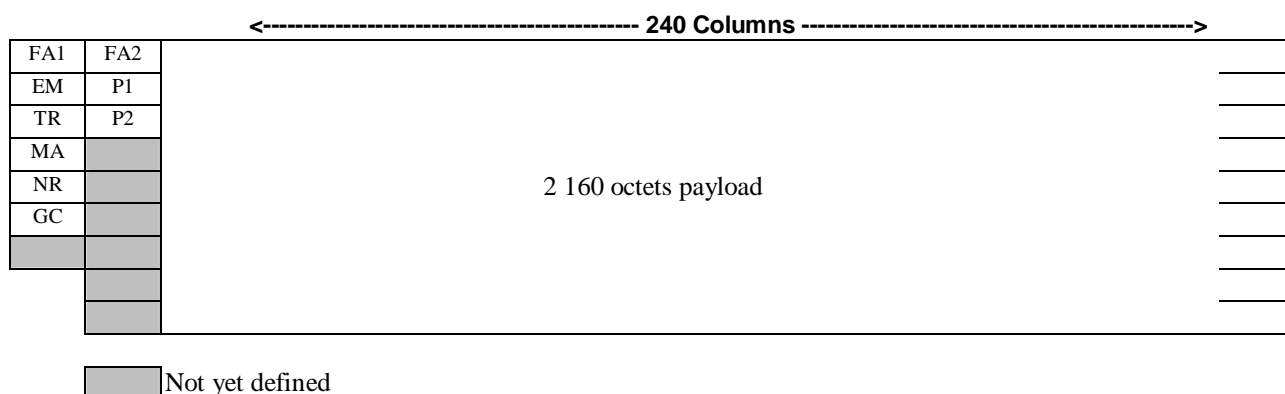

Figure B.1: Frame structure at 139 264 kbit/s

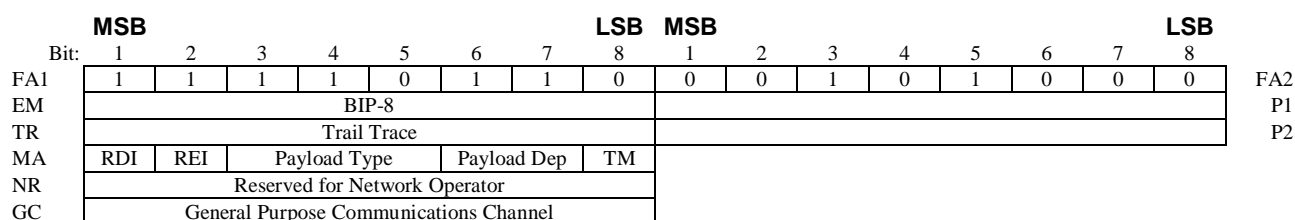

Figure B.2: Path overhead at 139 264 kbit/s

MSB	Most Significant Bit.
LSB	Least Significant Bit.
FA1	Frame Alignment byte (1).
FA2	Frame Alignment byte (2).
EM	Error Monitoring, Bit Interleaved Parity - 8 (8-bit). One byte is allocated for path error monitoring. This byte carries the end-to-end parity information even if the NR byte is changed by the network operator. In this case, the BIP-8 is updated (not recalculated) to reflect the change in NR.
TR	TRail trace. This byte is transmitted transparently from end-to-end.
MA	Maintenance and Adaptation. This byte is transmitted transparently from end-to-end.
NR	Network operator byte. This byte is allocated for maintenance purposes specific to network operators. Its end-to-end transparency is not guaranteed.
GC	General purpose Communications channel (e.g. to provide data/voice channel connection for maintenance purposes). This byte is transmitted transparently from end-to-end.
P1/2	Automatic protection switching. Bytes P1 and P2 are undefined for leased line applications.

NOTE: Further details of the frame structure can be found in ITU-T Recommendation G.832 (see annex F) of EN 300 690 and ETS 300 337 (see annex F).

Annex C (informative): Derivation of error performance limits

C.1 Introduction

Errors are caused by various influences such as:

- human intervention;
- thermal noise;
- induced voltages in equipment and cables due to lightning, radio transmissions and other electromagnetic effects;
- loss of synchronization following uncontrolled slips;
- joints and connections.

The main cause of errors is induced voltages and such errors frequently occur in dense bursts due to particular phenomena. Due to improvements in technology resulting in part from a greater understanding of electromagnetic effects, there is a long term trend for error rates to reduce.

Studies in ITU-T Recommendations have concluded that error rates for lines have a low dependence on distance.

C.2 Reference connections

ITU-T Recommendation G.826 (see annex F) contains error performance limits for a hypothetical reference connection of 27 500 km. In order to apply these figures to a leased line, it is necessary to define reference connections to represent the leased lines covered by the present document. A terrestrial reference connection and a satellite reference connection are defined in clauses C.2.1 and C.2.2 based on ITU-T Recommendation G.826 (see annex F).

C.2.1 Terrestrial connection

Figure C.1 shows the reference connection for a terrestrial connection used in the derivation of error performance limits specified in the present document.

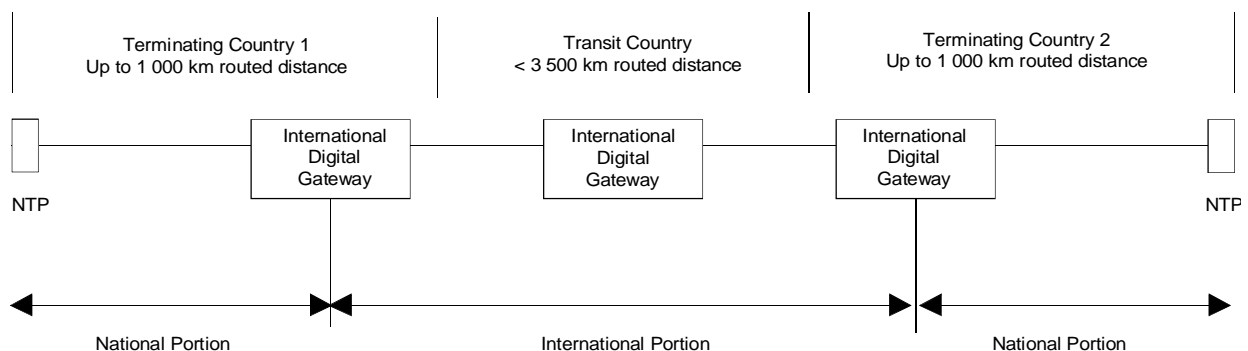

Figure C.1: Reference connection for terrestrial 140 Mbit/s digital leased line

The reference connection given in figure C.1 comprises two terminating countries and a single transit country. For each terminating country, there is a routed distance of up to 1 000 km between the NTP and the international digital gateway. For the transit country there is a single international gateway and a routed distance up to 3 500 km. The routed distance is given by 1,5 x straight line distance, except that for undersea cable the actual routed length should be used.

NOTE: This model allows for a total routed distance of up to 5 500 km. Although this reference connection shows separate national portions, the present document does not apportion errors between different countries and the errors may be apportioned differently.

C.2.2 Satellite connection

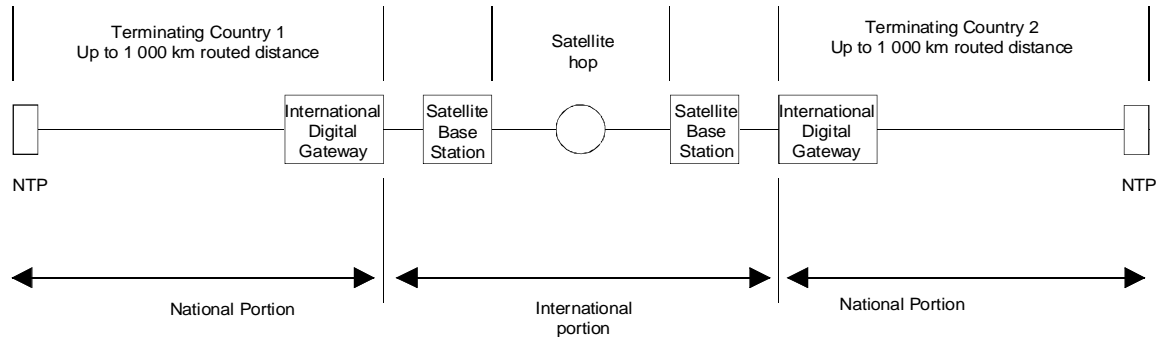

Figure C.2: Reference connection for satellite 140 Mbit/s digital leased line

The reference connection in figure C.2 contains a satellite link connecting the two terminating countries. For each terminating country a routed distances of 1 000 km is assumed.

C.3 Error performance objectives

Tables C.1 and C.2 show the percentage allocation of the overall error performance objectives specified in ITU-T Recommendation G.826 (see annex F) to the various portions of the leased lines specified in the reference connections (terrestrial and satellite) defined in clause C.2. The tables include both fixed allocations and distance dependent allocations of 1 % per 500 km routed distance.

Table C.1: Allocation of error performance objectives derived from G.826 - terrestrial connection

Path portion (terrestrial link)	Allocation
Terminating country 1 (fixed allocation)	17,5%
Terminating country 1 (routed 1 000 km)	2,0 %
International transit termination	1,0 %
International transit (fixed allocation)	2,0 %
International transit (routed 3 500 km)	7,0 %
International transit termination	1,0 %
Terminating country 2 (routed 1 000 km)	2,0 %
Terminating country 2 (fixed allocation)	17,5 %
TOTAL	50,0 %

Table C.2: Allocation of error performance objectives derived from G.826 -satellite connection

Path portion (satellite link)	Allocation
Terminating country 1 (fixed allocation)	17,5%
Terminating country 1 (routed 1 000 km)	2,0 %
International termination	2,0 %
Satellite connection	35,0%
International termination	2,0 %
Terminating country 2 (routed 1 000 km)	2,0 %
Terminating country 2 (fixed allocation)	17,5 %
TOTAL	78,0 %

NOTE: The inclusion of additional transit countries to the terrestrial connection would require an additional fixed allocation (2 %), transit termination (1 %) and a routed portion (1 % per 500 km). Further information is given in ITU-T Recommendation G.826 (see annex F).

ITU-T Recommendation G.826 (see annex F) defines error performance objectives in terms of errored seconds, severely errored seconds and background block errors for a hypothetical reference path of 27 500 km; these rates are given in table C.3, column 2.

The application of the percentage figures given in tables C.1 and C.2 to the error performance objectives given in ITU- Recommendation G.826 (see annex F) gives error rates for the D140U and D140S leased lines shown in table C.3 columns 3 and 4 for terrestrial and satellite connections.

Table C.3: Error performance objectives for D140U and D140S leased lines

Performance parameter	G.826	D140U / D140S terrestrial	D140U / D140S satellite
ESR	16,00 %	8,00 %	12,48 %
SESR	0,20 %	0,10 %	0,156 %
BBER	0,02 %	0,01 %	0,016 %
NOTE: The figures in this table have been rounded; exact figures have been used in the calculation of the limits in the following clauses.			

C.4 Long term error performance

The error performance ratio derived in clause C.3 for the specific reference connections can be used to calculate the long term error performance requirements, expressed as an absolute figure over a 24 hour period; these are given in row 1 of tables C.4 and C.5 for the terrestrial and satellite connections.

The error performance requirements specified are, however, statistical figures based on long term measurements (greater than one month) which are not statistically valid over a 24 hour measurement period. Therefore ITU-T Recommendation M.2100 (see annex F) presents a method of reducing these limits to 24 hour test limits S1 and S2. S1 is the limit below which there is confidence that the leased line meets the requirement, S2 is the limit above which there is confidence that the leased line fails to meet the requirement. Between S1 and S2 the results are inconclusive. Therefore, in order to have confidence that the leased line meets the long term requirement, the 24 hour test result should be better than the limit S1. In the event that the limit S1 is not met, the test should be repeated a second time.

S1 and S2 are derived from:

- $S1 = (\text{requirement}) - 2 \times \sqrt{(\text{requirement})}$;
- $S2 = (\text{requirement}) + 2 \times \sqrt{(\text{requirement})}$.

Table C.4: Derivation of 24 hour test limits for a block length of 17 408 bits - terrestrial connection

Parameter	ES	SES	BBE
Long term error performance	6 912 / 24 h	86 / 24 h	69 120 / 24 h
24 hour test limits			
accept (S1)	6 746 / 24 h	68 / 24 h	68 594 / 24 h
reject (S2)	7 078 / 24 h	105 / 24 h	69 646 / 24 h

Table C.5: Derivation of 24 hour test limits for a block length of 17 408 bits - satellite connection

Parameter	ES	SES	BBE
Long term error performance	10 783 / 24 h	135 / 24 h	107 827 / 24 h
24 hour test limits			
accept (S1)	10 575 / 24 h	112 / 24 h	107 170 / 24 h
reject (S2)	10 990 / 24 h	158 / 24 h	108 484 / 24 h

Annex D (informative): Availability

D.1 General

The availability of a leased line should be assessed over a long period of time and cannot be measured using a single test. ITU-T Recommendation M.1016 (see annex F) proposes that any observation period should be three calendar months. For the purpose of observing availability, the following terms should be considered.

D.1.1 Unavailability

$$\text{Unavailability} = \frac{\sum \text{Unavailability periods}}{\text{Observation period}}$$

(with unavailability generally expressed as a percentage).

D.1.2 Outage intensity

$$\text{Outage intensity} = \frac{\text{Number of unavailability periods}}{\text{Observation period}}$$

D.1.3 Mean time between failures

$$\text{Mean time between failures} = \frac{(\text{observation period}) - (\sum \text{Unavailability periods})}{\text{Number of unavailability periods}}$$

This equation is only valid for a high number of unavailability periods within the observation period.

D.1.4 Mean time to restore service

$$\text{Mean time to restore service} = \frac{\sum \text{Unavailability periods}}{\text{Number of unavailability periods}}$$

D.2 Recommendations

Table D.1 gives recommended target values for availability and outage intensity for leased lines based on the terrestrial and satellite reference connections of annex C. These figures are taken from EN 300 416 (see annex F) which provides values for 2 048 kbit/s path elements between customer premises. For the situations where the leased line connections are outside the scope of these reference connections, figures can be derived from EN 300 416 (see annex F).

Figures are given for "standard performance" and "high performance" leased lines. Customers who require a very high availability may require diverse routing of two or more lines. The mean value is the figure to be met for the average of the leased lines; the worst case value is the value that no leased line should exceed (i.e. be worse than this figure).

Table D.1: Target availability and outage intensity

Performance	Terrestrial				Satellite	
	Availability		Outage intensity (per year)		Availability	
	mean	worst case	mean	worst case	mean	worst case
Standard performance	97,3 %	94,7 %	590	1 590	undefined	97,0 %
High performance	99,5 %	98,2 %	230	625	undefined	99,2 %

With an unstructured leased line, the leased line provider cannot monitor the leased lines by standard means. If there is a defined structure within the bit stream, the leased line provider may be able to monitor the leased line using proprietary methods.

Annex E (informative): Bringing Into Service (BIS) limits

E.1 General

This annex specifies BIS limits for 140 Mbit/s leased lines which may be used by the leased line provider as part of the commissioning process to ensure that the in service performance limits are met.

BIS limits are given for errored seconds and severely errored seconds. There are no BIS limits for background block errors.

E.2 BIS limits

ITU-T Recommendation M.2100 (see annex F) defines BIS limits derived from the Reference Performance Objective (RPO). In this application, the RPO is taken as 50 % of the ratio specified in ITU-T Recommendation G.826 (see table C.3) (see annex F).

For the leased line, the BIS limits are 0,5 x RPO limits, with BIS testing generally performed over a 24 hour, two hour or 15 minute period. The long term performance objectives are statistical figures based on long term measurements (greater than one month) which are not statistically valid over a short measurement period. Therefore ITU-T Recommendation M.2100 (see annex F) presents a method of reducing these long term performance limits to short term BIS test limits S1 and S2. S1 is the limit below which bringing into service is accepted, S2 is the limit above which bringing into service is rejected. Between S1 and S2 the results are inconclusive.

BIS objective, S1 and S2 are derived from:

- BIS Objective = RPO/2;
- S1 = RPO/2 - 2 x $\sqrt{\text{RPO}/2}$;
- S2 = RPO/2 + 2 x $\sqrt{\text{RPO}/2}$.

Tables E.1 and E.2 give the 24 hour and 2 hour BIS accept and reject limits for terrestrial and satellite connections of the 140 Mbit/s leased lines. When testing over a 15 minute period, there should be no error or unavailability event.

Table E.1: BIS 24 hour test limits

Performance parameter	Terrestrial	Satellite
ES		
accept limit (S1)	1 645 / 24 hours	2 592 / 24 hours
reject limit (S2)	1 811 / 24 hours	2 800 / 24 hours
SES		
accept limit (S1)	12 / 24 hours	22 / 24 hours
reject limit (S2)	31 / 24 hours	45 / 24 hours

Table E.2: BIS 2 hour test limits

Performance parameter	Terrestrial	Satellite
ES		
accept limit (S1)	120 / 2 hours	195 / 2 hours
reject limit (S2)	168 / 2 hours	255 / 2 hours
SES		
accept limit (S1)	0 / 2 hours	0 / 2 hours
reject limit (S2)	4 / 2 hours	6 / 2 hours

Annex F (informative): Bibliography

- Council Directive 91/263/EEC of 29 April 1991 on the approximation of the laws of Member States concerning telecommunications terminal equipment, including the mutual recognition of their conformity.
- Council Directive 92/44/EEC of 5 June 1992 on the application of Open Network Provision to leased lines.
- Directive 98/13/EC of the European Parliament and of the Council of 12 February 1998 relating to telecommunications terminal equipment and satellite earth station equipment, including the mutual recognition of their conformity.
- ITU-T Recommendation M.1016 (1988): "Assessment of the service availability performance of international leased circuits".
- ITU-T Supplement number 3.8, Fascicle IV.4 (1988): "Guidelines concerning the measurement of jitter".
- ETSI EN 300 690: "Access and Terminals (AT); 140 Mbit/s digital leased lines (D140U and D140S); Terminal equipment interface".
- ETSI ETS 300 337: "Transmission and Multiplexing (TM); Generic frame structures for the transport of various signals (including Asynchronous Transfer Mode (ATM) cells and Synchronous Digital Hierarchy (SDH) elements) at the ITU-T Recommendation G.702 hierarchical rates of 2 048 kbit/s, 34 368 kbit/s and 139 264 kbit/s".
- ETSI EN 300 416: "Network Aspects (NA); Availability performance of path elements of international digital paths".
- ITU-T Recommendation G.114 (2000): "One-way transmission time".
- ITU-T Recommendation G.823 (2000): "The control of jitter and wander within digital networks which are based on the 2 048 kbit/s hierarchy".
- ITU-T Recommendation G.826 (1999): "Error performance parameters and objectives for international constant bit rate digital paths at or above the primary rate".
- ITU-T Recommendation G.832 (1998): "Transport of SDH elements on PDH networks - Frame and multiplexing structures".
- ITU-T Recommendation M.2100 (1995): "Performance limits for bringing-into-service and maintenance of international PDH paths, sections, and transmission systems".

History

Document history		
Edition 1	April 1996	Publication as ETS 300 688
V1.2.1	February 2001	One-step Approval Procedure OAP 20010629: 2001-02-28 to 2001-06-29