

Final draft **ETSI EN 300 673** V1.2.1 (1999-12)

Candidate Harmonized European Standard (Telecommunications series)

**Electromagnetic compatibility
and Radio spectrum Matters (ERM);
ElectroMagnetic Compatibility (EMC) standard
for Very Small Aperture Terminal (VSAT), Satellite News
Gathering (SNG), Satellite Interactive Terminals (SIT) and
Satellite User Terminals (SUT) Earth Stations operated in the
frequency ranges between 4 GHz and 30 GHz
in the Fixed Satellite Service (FSS)**



Reference

REN/ERM-EMC-201

Keywords

EMC, radio, satellite, testing, VSAT

ETSI

Postal address

F-06921 Sophia Antipolis Cedex - FRANCE

Office address

650 Route des Lucioles - Sophia Antipolis
Valbonne - FRANCE
Tel.: +33 4 92 94 42 00 Fax: +33 4 93 65 47 16
Siret N° 348 623 562 00017 - NAF 742 C
Association à but non lucratif enregistrée à la
Sous-Préfecture de Grasse (06) N° 7803/88

Internet

secretariat@etsi.fr
Individual copies of this ETSI deliverable
can be downloaded from
<http://www.etsi.org>
If you find errors in the present document, send your
comment to: editor@etsi.fr

Important notice

This ETSI deliverable may be made available in more than one electronic version or in print. In any case of existing or perceived difference in contents between such versions, the reference version is the Portable Document Format (PDF). In case of dispute, the reference shall be the printing on ETSI printers of the PDF version kept on a specific network drive within ETSI Secretariat.

Copyright Notification

No part may be reproduced except as authorized by written permission.
The copyright and the foregoing restriction extend to reproduction in all media.

© European Telecommunications Standards Institute 1999.
All rights reserved.

Contents

Intellectual Property Rights	5
Foreword.....	5
1 Scope	6
2 References	6
3 Definitions and abbreviations	7
3.1 Definitions	7
3.2 Abbreviations	8
4 General test conditions.....	8
4.1 Test conditions	8
4.2 Arrangements for tests.....	9
5 Performance assessment.....	9
5.1 General	9
5.2 Equipment configuration(s)	10
5.3 Equipment classification.....	11
6 Performance criteria	11
6.1 General	11
6.2 Performance criteria (C) for Continuous phenomena applied to the EUT.....	11
6.3 Performance criteria (TA) for Transient phenomena applied to a grade A EUT.....	12
6.4 Performance criteria (TB) for Transient phenomena applied to a grade B EUT	12
7 Overview tables.....	13
7.1 Emission	13
7.2 Immunity	13
8 Test methods and limits for emission tests of EUT	14
8.1 Test configuration.....	14
8.2 Enclosure 30 MHz to 1 000 MHz.....	14
8.2.1 Purpose	14
8.2.2 Test method	14
8.2.3 Limits.....	15
8.3 DC power input/output port.....	15
8.3.1 Purpose	15
8.3.2 Test method	15
8.3.3 Limits.....	15
8.4 AC mains power input/output port	16
8.4.1 Purpose	16
8.4.2 Test method	16
8.4.3 Limits.....	16
8.5 Harmonic current emissions (AC mains input port)	16
8.6 Voltage fluctuations and flicker (AC mains input port).....	16
9 Test methods and levels for immunity tests for EUT	17
9.1 Test configuration.....	17
9.2 Radio frequency electromagnetic field (80 to 1 000 MHz)	17
9.2.1 Purpose	17
9.2.2 Test method and level.....	17
9.2.3 Performance criteria.....	17
9.3 Electrostatic discharge.....	18
9.3.1 Purpose	18
9.3.2 Test method and levels.....	18
9.3.3 Performance criteria.....	18
9.4 Fast transients common mode.....	18
9.4.1 Purpose	18

9.4.2	Test method and levels.....	18
9.4.3	Performance criteria.....	19
9.5	RF common mode, 0,15 MHz to 80 MHz (current clamp injection).....	19
9.5.1	Purpose	19
9.5.2	Test method and level.....	19
9.5.3	Performance criteria.....	19
9.6	Voltage dips and interruptions.....	19
9.6.1	Purpose	19
9.6.2	Test method and levels.....	20
9.6.3	Performance criteria.....	20
9.7	Surges, common and differential mode	20
9.7.1	Purpose	20
9.7.2	Test method and levels.....	20
9.7.3	Performance criteria.....	21
Annex A (normative):	Clauses and/or subclauses for compliance with the essential requirements of the EC Council Directives.....	22
Annex B (normative):	Definitions of the ES within the scope of the present document.....	23
B.1	Transmit only and Transmit and receive Ku band VSATs.....	23
B.2	Receive-only Ku band VSATs.....	23
B.3	Transmit only and Transmit and receive C band VSATs.....	24
B.4	Receive-only C band VSATs	24
B.5	Satellite News Gathering (SNG) Ku band Transportable Earth Stations (TESs).....	25
B.6	Satellite Interactive Terminals (SITs).....	26
B.7	Satellite User Terminals (SUTs) transmitting in the frequency range 29,5 GHz to 30,0 GHz.....	27
B.8	Satellite User Terminals (SUTs) transmitting in the frequency range 27,5 GHz to 29,5 GHz.....	27
History	29

Intellectual Property Rights

IPRs essential or potentially essential to the present document may have been declared to ETSI. The information pertaining to these essential IPRs, if any, is publicly available for **ETSI members and non-members**, and can be found in SR 000 314: *"Intellectual Property Rights (IPRs); Essential, or potentially Essential, IPRs notified to ETSI in respect of ETSI standards"*, which is available from the ETSI Secretariat. Latest updates are available on the ETSI Web server (<http://www.etsi.org/ipr>).

Pursuant to the ETSI IPR Policy, no investigation, including IPR searches, has been carried out by ETSI. No guarantee can be given as to the existence of other IPRs not referenced in SR 000 314 (or the updates on the ETSI Web server) which are, or may be, or may become, essential to the present document.

Foreword

This Candidate Harmonized European Standard (Telecommunications series) has been produced by ETSI Technical Committee Electromagnetic compatibility and Radio spectrum Matters (ERM), and is now submitted for the Voting phase of the ETSI standards Two-step Approval Procedure.

The present document has been produced by ETSI in response to a mandate from the European Commission issued under Council Directive 98/34/EC (as amended) laying down a procedure for the provision of information in the field of technical standards and regulations.

The present document, is intended to become a Harmonized Standard, the reference of which will be published in the Official Journal of the European Communities referencing the Council Directive on the approximation of the laws of the Member States relating to electromagnetic compatibility ("the EMC Directive") (89/336/EEC [3] as amended) and relating to Article 3.1.b) of the R&TTE Directive 99/5/EC,

Technical specifications relevant to the EMC Directive are given in annex A.

The present document is based upon the Generic Standards EN 50081-1 [1] and EN 50082-1 [2] and other standards, where appropriate to meet the essential requirements of Council Directive 89/336/EEC [3]. For equipment which can be connected to the AC main supply, of EN 61000-3-2 [12] and EN 61000-3-3 [13] also apply where appropriate from 1-1-2001.

Proposed national transposition dates	
Date of latest announcement of this EN (doa):	3 months after ETSI publication
Date of latest publication of new National Standard or endorsement of this EN (dop/e):	6 months after doa
Date of withdrawal of any conflicting National Standard (dow):	36 months after doa

1 Scope

The present document covers the assessment of Very Small Aperture Terminals (VSAT), Satellite News Gathering (SNG) Transportable Earth Stations (TESs), Satellite Interactive Terminals (SITs) and Satellite User Terminals (SUTs) in respect of Electromagnetic Compatibility (EMC). Technical specifications related to the antenna port and emissions from the enclosure port of the equipment, are not included in the present document. Such specific technical specifications are found in the relevant product standards for the effective use of the radio spectrum.

The present document specifies the applicable EMC tests, the limits, and the minimum performance criteria for the Earth Stations (ES) defined in annex B.

The environment classification used in the present document refers to the environment classification used in the Generic Standards EN 50081-1 [1] and EN 50082-1 [2].

The EMC requirements have been selected to ensure an adequate level of compatibility for apparatus in residential, commercial and light industrial environments. The levels, however, do not cover extreme cases which may occur in any location but with a low probability of occurrence.

The present document may not cover those cases where a potential source of interference which is producing individually repeated transient phenomena or a continuous phenomenon is present, e.g. a radar or broadcast site in the near vicinity. In such a case it may be necessary to use special protection applied to either the source of interference, or the interfered part or both.

Compliance of ES equipment to the requirements of the present document does not imply compliance to any requirement related to the use of this ES (e.g. licensing requirements).

Compliance to the present document does not signify compliance to any safety requirements. However, it is the responsibility of the assessor of the equipment, that any observations regarding apparatus becoming dangerous or unsafe as a result of the application of the tests of the present document, should be recorded in the test report.

2 References

The following documents contain provisions which, through reference in this text, constitute provisions of the present document.

- References are either specific (identified by date of publication, edition number, version number, etc.) or non-specific.
- For a specific reference, subsequent revisions do not apply.
- For a non-specific reference, the latest version applies.
- A non-specific reference to an ETS shall also be taken to refer to later versions published as an EN with the same number.

- [1] EN 50081-1: "Electromagnetic compatibility - generic emission standard. Part 1: Residential, commercial and light industry".
- [2] EN 50082-1: "Electromagnetic compatibility - generic immunity standard. Part 1: Residential, commercial and light industry".
- [3] 89/336/EEC: "Council Directive on the approximation of the laws of the Member States relating to electromagnetic compatibility" as amended by 92/31/EEC: "Council Directive amending 89/336/EEC".
- [4] EN 55022: "Limits and methods of measurement of radio disturbance characteristics of information technology equipment".
- [5] CISPR 16-1: "Specification for radio disturbance and immunity measuring apparatus and methods; Part 1: Radio disturbance and immunity measuring apparatus".

- [6] EN 61000-4-3: "Electromagnetic compatibility (EMC) - Part 4: Testing and measurement techniques - Section 3: Radiated, radio-frequency electromagnetic field immunity test".
- [7] EN 61000-4-2: "Electromagnetic compatibility (EMC); Part 4: Testing and measurement techniques; Section 2: Electrostatic discharge immunity test; Basic EMC publication".
- [8] EN 61000-4-4: "Electromagnetic Compatibility (EMC); Part 4: Testing and measurements techniques - Section 4: Electrical fast transient/burst immunity test. Basic EMC publication".
- [9] EN 61000-4-6: "Electromagnetic Compatibility (EMC); Part 4: Testing and measurement techniques - Section 6: Immunity to conducted disturbances, induced by radio-frequency fields".
- [10] EN 61000-4-11: "Electromagnetic Compatibility (EMC); Part 4: Testing and measurements techniques - Section 11: Voltage dips, short interruptions and voltage variations immunity tests - Basic EMC publication".
- [11] EN 61000-4-5: "Electromagnetic Compatibility (EMC) - Part 4: Testing and measurements techniques - Section 5: Surge immunity test".
- [12] EN 61000-3-2 (1995): "Electromagnetic compatibility (EMC) - Part 3: Limits - Section 2: Limits for harmonic current emissions (equipment input current ≤ 16 A per phase)".
- [13] EN 61000-3-3 (1995): "Electromagnetic compatibility (EMC) - Part 3: Limits - Section 3: Limits of voltage fluctuations and flicker in low-voltage supply systems for equipment with rated current ≤ 16 A per phase".

3 Definitions and abbreviations

3.1 Definitions

For the purposes of the present document, the following terms and definitions apply:

ancillary equipment: equipment used in connection with an ES is considered as ancillary if the following three conditions are met:

- the equipment is intended for use in conjunction with an ES to provide additional operational and/or control features (e.g. to extend control to another position or location); and
- the equipment cannot be used on a stand alone basis to provide user functions independently of an ES; and
- the absence of the equipment does not inhibit the operation of the ES.

carrier-on state: transmit ES is in this state when it is authorized to transmit, and when it transmits a signal, either authorized by a Centralized Control and Monitoring Function (CCMF) or a Network Control Facility (NCF) when designed for unattended operation or by local control when designed for attended operation.

carrier-off state: transmit ES is in this state when it is authorized to transmit, and when it does not transmit any signal, either authorized by a CCMF or a NCF when designed for unattended operation or by local control when designed for attended operation.

NOTE: The existence of a carrier-off state depends on the system of transmission used. For ES designed for continuous transmission mode there may be no carrier-off state.

enclosure port: physical boundary of the apparatus through which an electromagnetic field may radiate or impinge (figure 1).

port: particular interface of the specified apparatus with the external electromagnetic environment (figure 1).

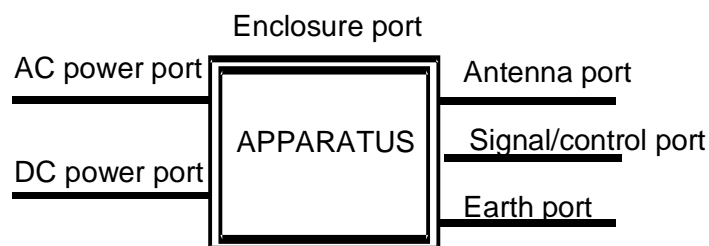

Figure 1: Examples of ports

transmission disabled state: transmit ES is in this state when it is not authorized to transmit either by a CCMF or a NCF respectively when designed for unattended operation or by local control when designed for attended operation.

3.2 Abbreviations

For the purposes of the present document, the following abbreviations apply:

CCMF	Centralized Control and Monitoring Functions
CMF	Control and Monitoring Functions
EIRP	Equivalent Isotropically Radiated Power
EMC	ElectroMagnetic Compatibility
ES	Earth Station
EUT	Equipment Under Test
FSS	Fixed Satellite Service
LISN	Line Impedance Stabilizing Network
LNB	Low Noise Block converter
NCF	Network Control Facility
QTMA	Quality of Transmission Measurement Apparatus
RF	Radio Frequency
rms	root mean square
SIT	Satellite Interactive Terminals
SNG	Satellite News Gathering
SUT	Satellite User Terminals
TES	Transportable Earth Station
VSAT	Very Small Aperture Terminal

4 General test conditions

4.1 Test conditions

For Earth Stations with or without ancillary equipment, and/or various terrestrial ports, the number of test configurations shall be determined. The assessment shall include sufficient representative configurations of the ES to adequately exercise the equipment. These configurations shall be recorded in the test report.

In the following clauses, the Equipment Under Test (EUT) is the ES with the selected configuration of ancillary equipment.

The equipment shall be tested under conditions which are within the manufacturers declared range of humidity, temperature, and supply voltage.

The test conditions shall be recorded in the test report.

4.2 Arrangements for tests

In order to measure the unwanted emissions and electromagnetic immunity under operational conditions, the following arrangements shall be provided by the manufacturer:

- a) a special test equipment to put the ES terminal in its normal operating mode, and providing the ES with a receive signal to emulate the operational conditions of reception. This equipment shall control the EUT, when it is capable of transmission, so that it switches between the transmission disabled, carrier-on and carrier-off states;
- b) the specific Quality of Transmission Measurement Apparatus (QTMA).

For the measurement of the quality of transmission a communications link shall be established and the wanted input signal shall be applied to the Radio Frequency (RF) input of the receiver via the antenna. For tests on the receiver, the level of the signal received from the test transmitter shall be as close as possible to the normal operation level of the EUT receiver. Care should be taken to avoid the broad band noise from the power amplifier of the test transmitter from influencing the measurement.

Adequate measures shall be taken to avoid the effects of the unwanted signal on the measuring equipment.

The special test equipment, the QTMA and the source of the wanted input signal shall be located outside the test environment. Adequate measures shall be taken to protect them from the effects of all the radiated fields within the test environment.

5 Performance assessment

5.1 General

The manufacturer shall, at the time of submission of the equipment for test, declare the intended use of the equipment, and provide full and complete documentation necessary for user operation, testing and evaluation purposes. This documentation shall include, but not be limited to:

- the ranges of the operational parameters, e.g. the power delivered to the antenna, the frequency ranges;
- an exhaustive list of ports, classified as either power, antenna or signal/control. Power ports shall further be classified as AC or DC power;
- the ancillary equipment to be combined with the ES for testing, if applicable;
- the user-control functions that are required for normal operation;
- the minimum quality of transmission, and the method to be used to assess it.

This information shall be in accordance with the documentation accompanying the equipment.

All this information shall be recorded in the test report.

5.2 Equipment configuration(s)

For radiation measurements in carrier-on state, the ES shall be put in a continuous transmit mode or to the maximum burst rate where applicable. The ES shall be operated at the highest normal operating Equivalent Isotropically Radiated Power (EIRP) or, if that is the maximum attainable, then 3 dB below such maximum.

A suggested test configuration is shown in figure 2.

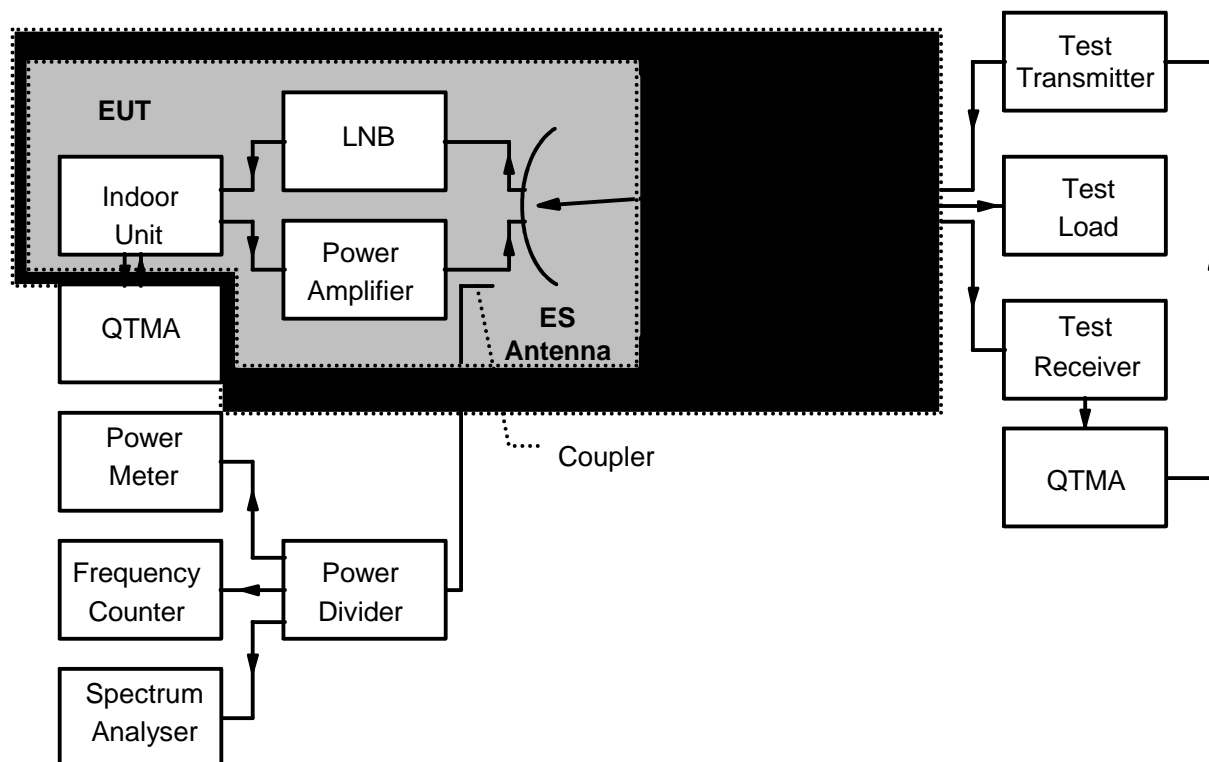

Figure 2: Suggested test configuration

For the tests, the ES antenna reflector and the test antenna may be removed at their flanges and be replaced by one direct wave guide connection.

The following test equipment shall be the means whereby the correct operation of the EUT is verified:

- the power meter measures the output power and is used to confirm the transmission disabled, carrier-on and carrier-off states and output level consistency;
- the frequency counter measures the centre frequency of the radiated carrier in the absence of modulation;
- the spectrum analyser measures the bandwidth of the transmission;
- the test receiver is used to demodulate the transmitted signal;
- the two QTMA are used in conjunction with each other to assess the quality of transmission;
- the test transmitter is used to control the switching between transmission disabled, carrier-on and carrier-off states by transmitting the control and monitoring signals.

5.3 Equipment classification

The equipment are classified into the two grades of service and for both grades the requirements provided represent "the minimum entry to the market requirement":

- grade A of ES for which short interruptions of transmission are accepted during immunity testing with EMC transient phenomena;
- grade B of ES for which no short interruption of transmission is accepted during immunity testing with EMC transient phenomena.

The applicable grade A or B shall be declared by the manufacturer, it shall be in accordance with the information contained in the instructions accompanying the ES, and shall be recorded in the test report.

6 Performance criteria

6.1 General

The definition of the functions of the EUT, including its ancillary equipment, to be checked during and after the EMC testing shall be declared by the manufacturer and recorded in the test report.

The equipment shall meet the minimum performance criteria as specified in subclauses 6.2, 6.3 and 6.4 and additionally the functions as declared by the manufacturer.

6.2 Performance criteria (C) for Continuous phenomena applied to the EUT

The EUT shall be considered to satisfy the immunity specifications if the following conditions are met during and after the exposure:

- a) the quality of transmission observed is no worse than that declared by the manufacturer (subclause 5.1);
- b) the EUT is able to be placed in the transmission disabled state, and does not leave that state without being commanded;
- c) when the EUT is in the transmission disabled state there is no change in the signal level;
- d) when the EUT is in the carrier-on state there is no change in the signal level or frequency;
- e) when the EUT is in the carrier-off state there is no increase of the signal level;
- f) for transmitting ESs, under no circumstances does the transmitter operate unintentionally during the test;
- g) the EUT operates as intended with no loss of user control functions, stored data and the communications link.

6.3 Performance criteria (TA) for Transient phenomena applied to a grade A EUT

The EUT shall be considered to satisfy the immunity specifications if the following conditions are met:

- during and after the series of individual exposures:
 - a) the EUT is able to be placed in the transmission disabled state, and does not leave that state without being commanded;
 - b) when the EUT is in the transmission disabled state there is no change in the signal level;
 - c) when the EUT is in the carrier-on state there is no change in the signal frequency or increase of the signal level;
 - d) when the EUT is in the carrier-off state there is no increase of the signal level;
 - e) for transmitting ESs, under no circumstances does the transmitter operate unintentionally during the test.
- at the conclusion of each exposure the quality of transmission observed shall be no worse than that declared by the manufacturer (subclause 5.1);
- at the conclusion of the total test comprising the series of individual exposures the EUT shall operate as intended with no loss of user control functions or stored data and the communications link shall remain maintained.

6.4 Performance criteria (TB) for Transient phenomena applied to a grade B EUT

The EUT shall be considered to satisfy the immunity specifications if the following conditions are met during and after the series of individual exposures:

- a) the quality of transmission observed is no worse than that declared by the manufacturer (subclause 5.1);
- b) under the test conditions the EUT is able to be placed in the transmission disabled state, and does not leave that state without being commanded;
- c) when the EUT is in the transmission disabled state there is no change in the signal level;
- d) when the EUT is in the carrier-on state there is no change in the signal level or frequency;
- e) when the EUT is in the carrier-off state there is no increase of the signal level;
- f) for transmitting ESs, under no circumstances does the transmitter operate unintentionally during the test;
- g) the EUT shall operate as intended with no loss of user control functions, stored data and the communications link.

7 Overview tables

7.1 Emission

Table 1: Emission measurements applicability

Phenomenon	Application	Equipment test requirement	Reference subclause in the present document	Reference document
Radiated emission	Enclosure of ancillary equipment	applicable	8.2	EN 55022 [4]
Conducted emission	DC power input/output port	applicable	8.3	EN 55022 [4] CISPR 16-1 [5]
Conducted emission	AC mains input/output port	applicable	8.4	EN 55022 [4]
Harmonic current emissions	AC mains input port	applicable	8.5	EN 61000-3-2 [12]
Voltage fluctuations and flicker	AC mains input port	applicable	8.6	EN 61000-3-3 [13]

7.2 Immunity

Table 2: Immunity tests applicability

Phenomenon	Application	Equipment test requirement	Reference subclause in the present document	Reference document
RF electro-magnetic field (80 MHz to 1 000 MHz)	Enclosure	applicable	9.2	EN 61000-4-3 [6]
Electrostatic discharge	Enclosure	applicable	9.3	EN 61000-4-2 [7]
Fast transients common mode	Signal and control ports, DC and AC power input ports	applicable	9.4	EN 61000-4-4 [8]
RF common mode (current clamp injection) 0,15 MHz to 80 MHz	Signal and control ports, DC and AC power input ports	applicable	9.5	EN 61000-4-6 [9]
Voltage dips and interruption	AC mains power input ports	applicable	9.6	EN 61000-4-11 [10]
Surges, common and differential mode	AC mains power input ports	applicable	9.7	EN 61000-4-5 [11]

8 Test methods and limits for emission tests of EUT

8.1 Test configuration

This subclause defines the requirements for test configurations described in the following subclauses. The requirements are as follows:

- the measurement shall be made in the operational mode producing the largest emission in the frequency band being investigated consistent with normal applications;
- the transmit carrier frequency and the receive carrier frequency shall be selected so that they give the maximum spurious radiation below 1 000 MHz;
- the equipment shall be configured in a manner which is representative of normal/typical operation, where practical;
- an attempt shall be made to maximize the detected radiated emission, for example by moving the cables of the equipment;
- if the equipment is part of a system, or can be connected to ancillary equipment, then it shall be acceptable to test the equipment while connected to the minimum configuration of ancillary equipment necessary to exercise the ports;
- the configuration and mode of operation during measurements shall be precisely noted in the test report;
- if the equipment has a large number of ports, then a sufficient number of them shall be selected to simulate actual operation conditions and to ensure that all the different types of termination are covered;
- ports which in normal operation are connected shall be connected to an ancillary equipment or to a representative piece of cable terminated to simulate the impedance of the ancillary equipment. RF input/output ports shall be correctly terminated;
- the tests shall be carried out at a point within the specified operating environmental range and at the rated supply voltage for the equipment.

8.2 Enclosure 30 MHz to 1 000 MHz

This test is applicable to the complete EUT.

8.2.1 Purpose

This test assesses the ability of the complete EUT to limit any radiated emission in the frequency band 30 MHz to 1 000 MHz from the enclosure.

8.2.2 Test method

The test method shall be in accordance with EN 55022 [4].

8.2.3 Limits

The radiated field strength shall not exceed the limits for EN 55022 [4] class B equipment given in table 3.

Table 3: Limits of radiated field strength at a test distance of 10 m

Frequency range	Limit (quasi-peak)
30 MHz to 230 MHz	30 dB μ V/m
230 MHz to 1 000 MHz	37 dB μ V/m
NOTE: The lower limit shall apply at the transition frequency.	

8.3 DC power input/output port

This test is applicable to EUT DC power input/output ports which may have DC cables longer than 3 m.

8.3.1 Purpose

This test assesses the ability of EUT to limit their internal noise from being present on the DC power input/output ports.

8.3.2 Test method

For equipment with a current consumption not exceeding 16 A the test method shall be in accordance with EN 55022 [4] and the Line Impedance Stabilizing Networks (LISN) shall be connected to a DC power source.

For equipment with a current consumption above 16 A the DC power ports shall be connected to 50 μ H LISNs with 50 Ω measurement ports. The LISNs shall be in accordance with the requirements of CISPR 16-1 [5].

A measuring receiver shall be connected to each LISN measurement port in turn and the conducted emission recorded. The LISN measurement ports not being used for measurement shall be terminated with a 50 Ω load.

The equipment shall be installed with a ground plane as defined in EN 55022 [4]. The reference earth point of the LISNs shall be connected to the reference ground plane with a conductor as short as possible.

The measurement receiver shall be in accordance with the requirements of CISPR 16-1 [5].

8.3.3 Limits

The conducted emissions from the EUT at the DC port shall not exceed the average limits and the quasi-peak limits for EN 55022 [4] class B equipment given in table 4 when using, respectively, an average detector receiver and a quasi-peak detector receiver and measured in accordance with the method described in subclause 8.3.2.

If, in a frequency range, the average limit is not exceeded when using a quasi-peak detector, the equipment shall be deemed to be not exceeding both limits and measurement with the average detector receiver is unnecessary, within this frequency range.

Table 4: Limits of conducted emissions at the DC power port

Frequency range	Quasi-peak	Average
0,15 MHz to 0,5 MHz	66 to 56 dB μ V	56 to 46 dB μ V
0,5 MHz to 5 MHz	56 dB μ V	46 dB μ V
5 MHz to 30 MHz	60 dB μ V	50 dB μ V
NOTE: The lower limits shall apply at the transition frequencies. The limit decreases linearly with the logarithm of the frequency in the range 0,15 MHz to 0,50 MHz.		

8.4 AC mains power input/output port

This test is applicable to the complete EUT.

8.4.1 Purpose

This test assesses the ability of the complete EUT to limit internal noise from being present on the AC mains power input/output ports.

8.4.2 Test method

The test method shall be in accordance with EN 55022 [4].

8.4.3 Limits

The conducted emissions from the EUT at the AC port shall not exceed the average limits and the quasi-peak limits given in table 5 when using, respectively, an average detector receiver and a quasi-peak detector receiver and measured in accordance with the method described in subclause 8.3.2. If, in a frequency range, the average limit is not exceeded when using a quasi-peak detector, the equipment shall be deemed to be not exceeding both limits and measurement with the average detector receiver is unnecessary, within this frequency range.

Table 5: Limits of conducted emissions at the AC mains port

Frequency range	Quasi-peak	Average
0,15 to 0,5 MHz	66 to 56 dB μ V	56 to 46 dB μ V
0,5 to 5 MHz	56 dB μ V	46 dB μ V
5 to 30 MHz	60 dB μ V	50 dB μ V
NOTE:	The lower limits shall apply at the transition frequencies. The limit decreases linearly with the logarithm of the frequency in the range 0,15 MHz to 0,50 MHz.	

8.5 Harmonic current emissions (AC mains input port)

The requirements of EN 61000-3-2 [12] for harmonic current emission apply for equipment covered by the scope of the present document, as appropriate.

8.6 Voltage fluctuations and flicker (AC mains input port)

The requirements of EN 61000-3-3 [13] for voltage fluctuations and flicker apply for equipment covered by the scope of the present document, as appropriate.

9 Test methods and levels for immunity tests for EUT

9.1 Test configuration

This subclause defines the requirements for test configurations described in the following subclauses. The requirements are as follows:

- for the immunity tests of receivers a communications link shall be established;
- if the equipment is part of a system, or can be connected to ancillary equipment, then it shall be acceptable to test the equipment while connected to the minimum configuration of ancillary equipment necessary to exercise the ports;
- for the immunity tests of transmit/receive EUT, a communications link shall be established between the EUT and the testing system. The EUT shall be placed in the operating mode;
- for the immunity tests of ancillary equipment, without a separate pass/fail criteria, the EUT with the ancillary equipment shall be used to judge whether the ancillary equipment meets the requirements;
- the configuration and mode of operation during measurements shall be precisely noted in the test report;
- if the equipment has a large number of ports, then a sufficient number of them shall be selected to simulate actual operation conditions and to ensure that all the different types of termination are covered;
- ports which in normal operation are connected to ancillary or other equipment (e.g. to terrestrial access ports), through interconnecting cables, shall be connected either to such equipment via a representative interconnecting cable, or to a representative termination to simulate the input/output characteristics of the ancillary or other equipment via a representative piece of interconnecting cable to connect such termination;
- the tests shall be carried out at a point within the specified normal operating environmental range and at the rated supply voltage for the equipment.

9.2 Radio frequency electromagnetic field (80 to 1 000 MHz)

This test is applicable to the complete EUT.

9.2.1 Purpose

This test assesses the ability of the complete EUT to operate as intended in the presence of a disturbing radio frequency electromagnetic field.

9.2.2 Test method and level

The test method shall be in accordance EN 61000-4-3 [6], with the following requirements applying:

- the applied electromagnetic field shall be amplitude modulated to a depth of 80 % by a sinusoidal audio signal of 1 kHz; without modulation, its effective amplitude shall be 3 V/m;
- the centre frequency of the electromagnetic field shall be incremented by 1 % steps of the momentary centre frequency, over the frequency range 80 MHz to 1 000 MHz;
- the frequencies selected during the test shall be recorded in the test report.

9.2.3 Performance criteria

The performance criteria C (subclause 6.2) shall apply.

9.3 Electrostatic discharge

This test is applicable to the complete EUT.

9.3.1 Purpose

This test assesses the ability of the complete EUT to operate as intended in the event of an electrostatic discharge.

9.3.2 Test method and levels

The test method shall be in accordance with EN 61000-4-2 [7].

The following requirements shall apply:

- for contact discharge, the test levels shall be ± 2 kV and ± 4 kV; for air discharge, the test levels shall be ± 2 kV, ± 4 kV and ± 8 kV (EN 61000-4-2 [7], clause 5);
- electrostatic discharges shall be applied to all exposed surfaces of the EUT except where the user documentation specifically indicates a requirement for appropriate protective measures (EN 61000-4-2 [7], subclause 8.3.1).

9.3.3 Performance criteria

The performance criteria TA (subclause 6.3) shall apply to grade A ES. The performance criteria TB (subclause 6.4) shall apply to grade B ES.

9.4 Fast transients common mode

This test is applicable to the complete EUT.

This test shall be performed on AC mains power input ports.

This test shall be performed on each signal port, control port and DC power input/output port which may be connected to a cable longer than 3 m.

This test shall not be carried out on those of the ports declared by the manufacturer as not intended to be used with cables longer than 3 m. The list of those ports not tested for this reason shall be recorded in the test report.

9.4.1 Purpose

This test assesses the ability of the complete EUT to operate as intended in the event of fast transients present on the input/output ports.

9.4.2 Test method and levels

The test method shall be in accordance with EN 61000-4-4 [8], with the following requirements applying:

- the test level for signal and control ports shall be 0,5 kV open circuit voltage as given in clause 5 of EN 61000-4-4 [8];
- the test level for DC power input/output ports shall be 0,5 kV open circuit voltage given in clause 5 of EN 61000-4-4 [8];
- the test level for AC mains power input ports shall be 1 kV open circuit voltage as given in clause 5 of EN 61000-4-4 [8].

For AC power input and DC power input/output ports the transients shall be applied (in parallel) to all the wires in the cable with reference to the cabinet reference ground, i.e. line-to-ground, (true common mode), with a source impedance of 50 Ω .

9.4.3 Performance criteria

The performance criteria TA (subclause 6.3) shall apply to grade A ES. The performance criteria TB (subclause 6.4) shall apply to grade B ES.

9.5 RF common mode, 0,15 MHz to 80 MHz (current clamp injection)

This test is applicable to the complete EUT.

This test shall be performed on each signal, control and DC power and AC mains power input/output port of the EUT which may have a cable longer than 1 m.

This test shall not be carried out on those of the ports declared by the manufacturer as not intended to be used with cables longer than 1 m. The list of those ports not tested for this reason shall be recorded in the test report.

9.5.1 Purpose

This test assesses the ability of the complete EUT to operate as intended in the presence of a radio frequency electromagnetic disturbance on the input/output ports.

9.5.2 Test method and level

The test method shall be the current clamp injection method in accordance with EN 61000-4-6 [9], with the following requirements applying:

- the test signal shall be amplitude modulated to a depth of 80 % by a sinusoidal audio signal of 1 kHz;
- the centre frequency of the test signal shall be incremented by 50 kHz steps over the frequency range 150 kHz to 5 MHz and by 1 % steps of the momentary centre frequency, over the frequency range 5 MHz to 80 MHz;
- without modulation, the rms value of the amplitude of the test signal shall be 3 V, at a transfer impedance of 150 Ω . This test level corresponds to the severity level 2 of EN 61000-4-6 [9];
- no intrusive or direct connection shall be made to any of the lines of any input/output port, therefore the current clamp injection method shall be used;
- the test shall be performed over the centre frequency range 150 kHz to 80 MHz;
- the centre frequencies selected during the test shall be recorded in the test report.

9.5.3 Performance criteria

The performance criteria C (subclause 6.2) shall apply.

9.6 Voltage dips and interruptions

These tests are applicable for the complete EUT powered by AC mains.

These tests shall be performed on AC mains power input ports.

9.6.1 Purpose

These tests assess the ability of the complete EUT to operate as intended in the event of voltage dips and interruptions present on the AC mains power input ports.

9.6.2 Test method and levels

The test method shall be in accordance with EN 61000-4-11 [10].

The test levels shall be:

- a) a voltage dip corresponding to a reduction of the supply voltage of 30 % for 10 ms;
- b) a voltage dip corresponding to a reduction of the supply voltage of 60 % for 100 ms;
- c) a voltage interruption corresponding to a reduction of the supply voltage of more than 95 % for 5 000 ms.

9.6.3 Performance criteria

- a) for a voltage dip corresponding to a reduction of the supply voltage of 30 % for 10 ms, the performance criteria C (subclause 6.2) shall apply;
- b) for a voltage dip corresponding to a reduction of the supply voltage of 60 % for 100 ms, the performance criteria TA (subclause 6.3) shall apply to grade A ES, and the performance criteria TB (subclause 6.4) shall apply to grade B ES.
 - In addition, when the equipment is powered solely from the AC mains supply (without the use of a parallel battery back up) communications need not have been maintained and may have to be re-established, and volatile user data may have been lost;
 - In the event of loss of communications and/or user data, this fact shall be recorded in the test report.
- c) For a voltage interruption corresponding to a reduction of the supply voltage of more than 95 % for 5 000 ms, the following performance criteria shall apply:
 - for equipment fitted with or connected to a battery back-up the performance criteria TA (subclause 6.3) shall apply to both grade A and grade B ES;
 - for equipment powered solely from the AC mains supply (without the use of a parallel battery back-up) communications need not have been maintained and may have to be re-established, and volatile user data may have been lost.
 - No unintentional response shall occur at the end of the test.

In the event of loss of communications and/or user data, this fact shall be recorded in the test report.

9.7 Surges, common and differential mode

These tests are applicable to the complete EUT.

These tests shall be performed on AC mains power input ports.

9.7.1 Purpose

These tests assess the ability of the complete EUT to operate as intended in the event of surges present on the AC mains power input ports.

9.7.2 Test method and levels

The test method shall be in accordance with EN 61000-4-5 [11].

- the test level shall be 1 kV open circuit voltage for common mode and 0,5 kV open circuit voltage for differential mode;
- the common mode surges shall be applied (in parallel) to all the wires in the cable, with reference to the cabinet reference ground with a series resistance of 10 Ω .

9.7.3 Performance criteria

The performance criteria TA (subclause 6.3) shall apply to grade A ES. The performance criteria TB (subclause 6.4) shall apply to grade B ES.

Annex A (normative): Clauses and/or subclauses for compliance with the essential requirements of the EC Council Directives

Table A.1: Clauses and/or subclauses for compliance with the essential requirements of the EC Council Directives

Clause/subclause number and title		Corresponding article of Council Directive 89/336/EEC [3]	Qualifying remark
8	Test methods and limits for emission tests		
8.2	Enclosure (30 MHz to 1 000 MHz)	4 (a)	
8.3	DC power input/output	4 (a)	
8.4	AC mains	4 (a)	
8.5	Harmonic current emissions	4 (a)	
8.6	Voltage fluctuations and flicker	4 (a)	
9	Test methods and limits for immunity tests		
9.2	Radio frequency electromagnetic field (80 MHz to 1 000 MHz)	4 (b)	
9.3	Electrostatic discharge	4 (b)	
9.4	Fast transients common mode	4 (b)	
9.5	RF common mode 0, 15 MHz to 80 MHz (current clamp injection)	4 (b)	
9.6	Voltage dips and interruptions	4 (b)	
9.7	Surges, common and differential mode	4 (b)	

Annex B (normative): Definitions of the ES within the scope of the present document

The following ES are defined in the present document:

B.1 Transmit only and Transmit and receive Ku band VSATs

The present document applies to transmit only and also to transmit and receive Very Small Aperture Terminals (VSATs) operating as part of a satellite network (e.g. star, meshed or point to point) used for the distribution and/or exchange of information between users.

In such a network a Centralized Control and Monitoring Functions (CCMF) is responsible for the monitoring and control of VSATs.

These VSATs have the following characteristics:

- operating in the exclusive part of the Ku band allocated to the Fixed Satellite Services (FSS), 14,00 GHz to 14,25 GHz (Earth-Space), 12,50 GHz to 12,75 GHz (Space-Earth), and/or in the shared parts of the Ku band, allocated to the FSS and Fixed Services (FS), 14,25 GHz to 14,50 GHz (Earth-Space) and/or 10,70 GHz to 11,70 GHz (Space-Earth);
- in these frequency bands linear polarization is normally used and the system operates through satellites at 3° spacing;
- designed usually for unattended operation;
- antenna diameter not exceeding 3,8 m, or equivalent corresponding aperture.

These VSATs comprise both the "outdoor unit", usually composed of the antenna subsystem and associated power amplifier and Low Noise Block (LNB), and the "indoor unit" composed of the remaining part of the communication chain, including the cable between these two units.

The present document applies to the VSAT with its ancillary equipment and its various terrestrial ports, and operated under the conditions which are within the ranges of humidity, temperature and supply voltage declared by the manufacturer.

B.2 Receive-only Ku band VSATs

The present document applies to receive-only Very Small Aperture Terminals (VSATs) operating as part of a satellite network (e.g. star, meshed or point to point) used for the distribution of information.

These VSATs have the following characteristics:

- operating in the exclusive space-to-earth part of the Ku band allocated to the Fixed Satellite Service (FSS), 12,50 GHz to 12,75 GHz (Space-Earth), and/or in the shared parts of the Ku band, allocated to the FSS and Fixed Service (FS), 10,70 GHz to 11,70 GHz (Space-Earth);
- in these frequency bands linear polarization is normally used and the system operates through satellites at 3° spacing;
- designed usually for unattended operation;
- antenna diameter not exceeding 3,8 m, or equivalent corresponding aperture.

These VSATs comprise both the "outdoor unit", usually composed of the antenna subsystem and associated Low Noise Block (LNB), and the "indoor unit" composed of the remaining part of the communication chain, including the cable between these two units.

The present document applies to the VSAT with its ancillary equipment and its various terrestrial ports, and operated under the conditions which are within the ranges of humidity, temperature and supply voltage declared by the manufacturer.

B.3 Transmit only and Transmit and receive C band VSATs

The present document applies to transmit only and also to transmit and receive Very Small Aperture Terminals (VSATs) operating as part of a satellite network (e.g. star, meshed or point to point) used for the distribution and/or exchange of information between users.

In such a network a Centralized Control and Monitoring Function (CCMF) is responsible for the monitoring and control of VSATs.

These VSATs have the following characteristics:

- operating in the exclusive part of the C-band allocated to the Fixed Services (FS) and to the Fixed Satellite Services (FSS), 5,850 GHz to 6,425 GHz (Earth-Space), 3,625 GHz to 4,200 GHz (Space-Earth);
- in these frequency bands circular and linear polarizations are used and the system operates through satellites at 3° spacing;
- designed usually for unattended operation;
- antenna diameter not exceeding 7,3 m, or equivalent corresponding aperture.

These VSATs comprise both the "outdoor unit", usually composed of the antenna subsystem and associated power amplifier and Low Noise Block (LNB), and the "indoor unit" composed of the remaining part of the communication chain, including the cable between these two units.

The present document applies to the VSAT with its ancillary equipment and its various terrestrial ports, and operated under the conditions which are within the ranges of humidity, temperature and supply voltage declared by the manufacturer.

B.4 Receive-only C band VSATs

The present document applies to receive-only Very Small Aperture Terminals (VSATs) operating as part of a satellite network (e.g. star, meshed or point to point) used for the distribution of information.

These VSATs have the following characteristics:

- operating in the exclusive part of the C-band allocated to the Fixed Services (FS) and to the Fixed Satellite Services (FSS) 3,625 GHz to 4,200 GHz (Space-Earth);
- in these frequency bands circular and linear polarizations are used and the system operates through satellites at 3° spacing;
- designed usually for unattended operation;
- antenna diameter not exceeding 7,3 m, or equivalent corresponding aperture.

These VSATs comprise both the "outdoor unit", usually composed of the antenna subsystem and associated Low Noise Block (LNB), and the "indoor unit" composed of the remaining part of the communication chain, including the cable between these two units.

The present document applies to the VSAT with its ancillary equipment and its various terrestrial ports, and operated under the conditions which are within the ranges of humidity, temperature and supply voltage declared by the manufacturer.

B.5 Satellite News Gathering (SNG) Ku band Transportable Earth Stations (TESs)

The present document applies to Transportable Earth Stations (TESs) used for Satellite News Gathering (SNG) which can be either an unforeseen or pre-planned activity. The SNG TES is capable of transmitting television signals and associated audio or programme audio only towards a satellite positioned on the geostationary orbit. The modulation method may be either analogue or digital. Such transmissions are point-to-point or point-to-multipoint but not for general broadcast reception.

A Transportable Earth Station (TES) is an earth station that can be relocated at any time to a different fixed operating location but is not intended to operate during the relocation period. The TES can be either vehicle mounted or packet for transportation. The TESs considered in the present document are those designed to operate whilst stationary.

This earth station should include a capability to receive from the satellite for antenna pointing purposes and to monitor its own transmission where the satellite transmission beam permits. The receive equipment could also be used in the process of the two-way communication to control and co-ordinate operation.

These TESs have the following characteristics:

- operating in the exclusive part of the Ku band allocated to the Fixed Satellite Services (FSS), 12,75 GHz to 13,25 GHz (Earth - Space), 13,75 GHz to 14,50 GHz (Earth-Space), 10,70 GHz to 11,70 GHz (Space-Earth), and/or 12,50 GHz to 12,75 GHz (Space-Earth). Frequencies could be selected from through the entire frequency range or be restricted to a range completely enclosed within those bands. These bands are partly shared between FSS and Fixed Service (FS).
- TES does not operate in any of the Mobile Satellite Service (MSS), e.g. LMSS (Land), AMSS (Aeronautical) and MMSS (Maritime). These are referred to as mobile earth stations;
- in these frequency bands linear polarization is normally used and the system operates through satellites with 3° spacing;
- designed for attended operation;
- antenna diameter not exceeding 5 m, or equivalent corresponding aperture.

NOTE: At present the Radio Regulations restrict the use of the 13,75 GHz to 14,00 GHz band to earth stations having an antenna diameter of 4,5 m or greater and having a transmitting EIRP between 68 dBW and 85 dBW.

These SNG TESs comprise both the antenna sub-system and the associated transmit and receive sub-systems.

The present document does not contain any requirement, recommendation or information about the method of modulation. Such modulation could result in the transmission being either analogue or digital or both simultaneously. The present document does not contain any requirement, recommendation or information about the baseband signals used in the modulation process. Such baseband signals could be pure analogue, digital or a mixture of analogue and digital.

B.6 Satellite Interactive Terminals (SITs)

The present document applies to Satellite Interactive Terminals operating as part of a satellite network. These SITs are used for reception of audio-visual signals as well as data and for providing a return channel for interactive services via satellite.

In such a network a Network Control Facility (NCF) is responsible for the monitoring and control of the transmit functions of the SITs.

These SITs have the following characteristics:

- reception is in the Fixed Satellite Service (FSS) frequency ranges from 10,70 GHz to 11,70 GHz and from 12,50 GHz to 12,75 GHz as well as the Broadcast Satellite Service (BSS) frequency range from 11,70 GHz to 12,50 GHz;
- transmission is in the frequency band allocated to FSS on a primary basis from 29,5 GHz to 30,0 GHz;
- these SITs transmit through geostationary satellites with spacings down to 2° away from any other geostationary satellite operating in the same frequency band and covering the same area;
- linear or circular polarization is used for transmission or reception;
- the received signals may be analogue and/or digital;
- transmitted signals are always of digital nature;
- the SIT antenna diameter does not exceed 1,8 m, or equivalent corresponding aperture;
- the SIT is designed for unattended operations.

The equipment considered in the present document comprises both the outdoor unit, usually composed of the antenna subsystem and associated upconverter, power amplifier and Low Noise Block (LNB) downconverter, and the indoor unit, usually composed of receive and transmit logic as well as the modulator, including cables between these two units.

The present document applies to the SIT in all its operational conditions, with its ancillary equipment and its various ports and when operated under the conditions which are within the range of humidity, temperature, and supply voltage declared by the manufacturer.

B.7 Satellite User Terminals (SUTs) transmitting in the frequency range 29,5 GHz to 30,0 GHz

The present document applies to Satellite User Terminals (SUT) operating as part of a satellite network. These SUTs are used mainly for transmission and reception of data signals.

In such a network a Network Control Facility (NCF) is responsible for the monitoring and control of the transmit functions of the SUTs.

These SUTs have the following characteristics:

- reception is in the frequency band allocated to the Fixed Satellite Service (FSS) on a primary basis from 19,70 GHz to 20,20 GHz;
- transmission is in the frequency band allocated to the Fixed Satellite Service (FSS) on a primary basis from 29,5 GHz to 30,0 GHz;
- these SUTs transmit through geostationary satellites with spacing down to 2° away from any other geostationary satellite operating in the same frequency band and covering the same area;
- linear or circular polarization is used for transmission or reception;
- the received signals may be analogue and/or digital;
- transmitted signals are always of digital nature;
- the SUT antenna diameter does not exceed 1,8 m, or equivalent corresponding aperture;
- the SUT is designed for unattended operations.

The equipment considered in the present document comprises both the outdoor unit, usually composed of the antenna subsystem and associated upconverter, power amplifier and Low Noise Block (LNB) downconverter, and the indoor unit, usually composed of receive and transmit logic as well as the modulator, including cables between these two units.

The present document applies to the SUT in all its operational conditions with its ancillary equipment and its various ports and when operated under the conditions which are within the range of humidity, temperature and supply voltage declared by the manufacturer.

B.8 Satellite User Terminals (SUTs) transmitting in the frequency range 27,5 GHz to 29,5 GHz

The present document applies to Satellite User Terminals (SUT) operating as part of a satellite network. These SUTs are used mainly for transmission and reception of data signals.

In such a network a Network Control Facility (NCF) is responsible for the monitoring and control of the transmit functions of the SUTs.

These SUTs have the following characteristics:

- reception is in the frequency band allocated to the Fixed Satellite Service (FSS) from 17,70 GHz to 19,70 GHz;
- transmission is in the frequency band allocated to the Fixed Satellite Service (FSS) from 27,5 GHz to 29,5 GHz;
- these SUTs transmit through geostationary satellites with spacing down to 2° away from any other geostationary satellite operating in the same frequency band and covering the same area;
- linear or circular polarization is used for transmission and reception;
- the received signals may be analogue and/or digital;
- transmitted signals are always of digital nature;
- the SUT antenna diameter does not exceed 1,8 m, or equivalent corresponding aperture;
- the SUT is designed for unattended operations.

The equipment considered in the present document comprises both the outdoor unit, usually composed of the antenna subsystem and associated upconverter, power amplifier and Low Noise Block (LNB) downconverter, and the indoor unit, usually composed of receive and transmit logic as well as the modulator, including cables between these two units.

The present document applies to the SUT in all its operational conditions with its ancillary equipment and its various ports and when operated under the conditions which are within the range of humidity, temperature and supply voltage declared by the manufacturer.

History

Document history		
Edition 1	March 1997	Publication as ETS 300 673
V1.2.1	February 1999	Public Enquiry PE 9924: 1999-02-12 to 1999-06-11
V1.2.1	December 1999	Vote V 200007: 1999-12-20 to 2000-02-18