

# ETSI EN 300 497-8 V0.3.2 (1999-09)

---

*European Standard (Telecommunications series)*

**Digital Enhanced Cordless Telecommunications (DECT);  
Common Interface (CI); Test Case Library (TCL);  
Part 8: Test Suite Structure (TSS) and Test Purposes (TP) -  
Network (NWK) layer - Fixed radio Termination (FT)**

---



---

**Reference**

---

REN/DECT-040131-8 (4lq0011c.PDF)

---

**Keywords**

---

DECT, network, FT, testing, TSS&TP**ETSI**

---

**Postal address**

---

F-06921 Sophia Antipolis Cedex - FRANCE

---

**Office address**

---

650 Route des Lucioles - Sophia Antipolis  
Valbonne - FRANCE  
Tel.: +33 4 92 94 42 00 Fax: +33 4 93 65 47 16  
Siret N° 348 623 562 00017 - NAF 742 C  
Association à but non lucratif enregistrée à la  
Sous-Préfecture de Grasse (06) N° 7803/88

---

**Internet**

---

secretariat@etsi.fr  
Individual copies of this ETSI deliverable  
can be downloaded from  
<http://www.etsi.org>  
If you find errors in the present document, send your  
comment to: editor@etsi.fr

---

**Copyright Notification**

---

No part may be reproduced except as authorized by written permission.  
The copyright and the foregoing restriction extend to reproduction in all media.

© European Telecommunications Standards Institute 1999.  
All rights reserved.

# Contents

Intellectual Property Rights.....	5
Foreword .....	5
1 Scope.....	6
2 References.....	6
3 Definitions and abbreviations .....	7
3.1 Definitions .....	7
3.2 Abbreviations.....	7
4 Test Suite Structure (TSS) .....	9
4.1 TSS overview.....	9
4.2 Test groups.....	10
4.2.1 Protocol groups .....	10
4.2.1.1 Call Control (CC) .....	10
4.2.1.2 Mobility Management (MM).....	10
4.2.1.3 Lower layer Management Entity (ME) .....	10
4.2.1.4 Link Control (LC).....	10
4.2.1.5 Call Independent Supplementary Services (CISS).....	10
4.2.1.6 Connection Oriented Message Services (COMS).....	10
4.2.1.7 Connectionless Message Services (CLMS) .....	10
4.2.2 Main test groups .....	10
4.2.2.1 Basic Interconnection tests (IT).....	10
4.2.2.2 Capability tests (CA) .....	10
4.2.2.3 Valid Behaviour tests (BV) .....	10
4.2.2.4 Invalid Behaviour tests (BI).....	11
4.2.2.5 Inopportune Behaviour tests (BO).....	11
4.2.2.6 Timer expiry and counter mismatch tests (TI).....	11
5 Test Purposes (TP).....	11
5.1 Introduction.....	11
5.1.1 TP definition conventions .....	11
5.1.2 References .....	11
5.1.3 TP naming conventions .....	12
5.2 CC test purposes .....	12
5.2.1 CC/IT test purposes.....	13
5.2.2 CC/CA test purposes .....	13
5.2.3 CC/BV test purposes .....	13
5.2.3.1 CC/BV/OC test purposes.....	14
5.2.3.2 CC/BV/IC test purposes .....	14
5.2.3.3 CC/BV/CI test purposes .....	15
5.2.3.4 CC/BV/CR test purposes .....	16
5.2.3.5 CC/BV/SC test purposes.....	17
5.2.3.6 CC/BV/PM test purposes.....	17
5.2.3.7 CC/BV/RS test purposes.....	17
5.2.3.8 CC/BV/HP test purposes .....	18
5.2.4 CC/BO test purposes .....	18
5.2.5 CC/BI test purposes.....	19
5.2.6 CC/TI test purposes.....	19
5.3 MM test purposes.....	20
5.3.1 MM/IT test purposes .....	20
5.3.2 MM/CA test purposes .....	20
5.3.3 MM/BV test purposes .....	20
5.3.3.1 MM/BV/ID test purposes .....	20
5.3.3.2 MM/BV/AU test purposes .....	21
5.3.3.3 MM/BV/LO test purposes .....	22
5.3.3.4 MM/BV/AR test purposes .....	23

5.3.3.5	MM/BV/KA test purposes .....	23
5.3.3.6	MM/BV/PR test purposes .....	24
5.3.3.7	MM/BV/CH test purposes .....	24
5.3.3.8	MM/BV/HP test purposes .....	25
5.3.4	MM/BO test purposes .....	26
5.3.5	MM/BI test purposes .....	26
5.3.6	MM/TI test purposes .....	27
5.4	ME test purposes .....	27
5.4.1	ME/BV test purposes .....	28
5.4.2	ME/BO test purposes .....	28
5.5	LC test purposes .....	28
5.5.1	LC/BV test purposes .....	28
5.5.1.1	LC/BV/LE test purposes .....	29
5.5.1.2	LC/BV/LR test purposes .....	29
5.5.1.3	LC/BV/LS test purposes .....	29
5.5.1.4	LC/BV/CL test purposes .....	30
5.5.2	LC/BI test purposes .....	30
5.5.3	LC/TI test purposes .....	30
5.6	IS test purposes .....	30
5.6A	IS/BV test purposes .....	31
5.7	MO test purposes .....	31
5.8	CL test purposes .....	31
5.9	CL/BV test purposes .....	31
	Bibliography .....	32
	History .....	33

## Intellectual Property Rights

IPRs essential or potentially essential to the present document may have been declared to ETSI. The information pertaining to these essential IPRs, if any, is publicly available for **ETSI members and non-members**, and can be found in SR 000 314: "*Intellectual Property Rights (IPRs); Essential, or potentially Essential, IPRs notified to ETSI in respect of ETSI standards*", which is available from the ETSI Secretariat. Latest updates are available on the ETSI Web server (<http://www.etsi.org/ipr>).

Pursuant to the ETSI IPR Policy, no investigation, including IPR searches, has been carried out by ETSI. No guarantee can be given as to the existence of other IPRs not referenced in SR 000 314 (or the updates on the ETSI Web server) which are, or may be, or may become, essential to the present document.

## Foreword

This European Standard (Telecommunications series) has been produced by ETSI Project Digital Enhanced Cordless Telecommunications (DECT).

The present document is part 8 of a multi-part EN covering the Common Interface (CI) Test Case Library (TCL), as identified below:

- Part 1: "Test Suite Structure (TSS) and Test Purposes (TP) for Medium Access Control (MAC) layer";
- Part 2: "Abstract Test Suite (ATS) for Medium Access Control (MAC) layer - Portable radio Termination (PT)";
- Part 3: "Abstract Test Suite (ATS) for Medium Access Control (MAC) layer - Fixed radio Termination (FT)";
- Part 4: "Test Suite Structure (TSS) and Test Purposes (TP) - Data Link Control (DLC) layer";
- Part 5: "Abstract Test Suite (ATS) - Data Link Control (DLC) layer";
- Part 6: "Test Suite Structure (TSS) and Test Purposes (TP) - Network (NWK) layer - Portable radio Termination (PT)";
- Part 7: "Abstract Test Suite (ATS) for Network (NWK) layer - Portable radio Termination (PT)";
- Part 8: "Test Suite Structure (TSS) and Test Purposes (TP) - Network (NWK) layer - Fixed radio Termination (FT)";**
- Part 9: "Abstract Test Suite (ATS) for Network (NWK) layer - Fixed radio Termination (FT)".

<b>National transposition dates</b>	
Date of adoption of this EN:	27 August 1999
Date of latest announcement of this EN (doa):	30 November 1999
Date of latest publication of new National Standard or endorsement of this EN (dop/e):	31 May 2000
Date of withdrawal of any conflicting National Standard (dow):	31 May 2000

---

# 1 Scope

The present document contains the test specification for the Digital Enhanced Cordless Telecommunications (DECT) (EN 300 175 parts 1 to 8 [1] to [8]).

The objective of this test specification is to provide a basis for approval tests for DECT equipment giving a high probability of air interface inter-operability between different manufacturer's DECT equipment. This test specification defines the Test Suite Structure (TSS) and Test Purposes (TP) for testing of the Network (NWK) layer at the Fixed radio Termination (FT).

The ISO standard for the methodology of conformance testing (ISO/IEC 9646-1 [12]) as well as the ETSI rules for conformance testing (ETS 300 406 [9]) are used as a basis for the test methodology.

Test specifications for the Physical layer (PHL) are provided in other DECT standards.

---

# 2 References

The following documents contain provisions which, through reference in this text, constitute provisions of the present document.

- References are either specific (identified by date of publication, edition number, version number, etc.) or non-specific.
- For a specific reference, subsequent revisions do not apply.
- For a non-specific reference, the latest version applies.
- A non-specific reference to an ETS shall also be taken to refer to later versions published as an EN with the same number.

- [1] EN 300 175-1: "Digital Enhanced Cordless Telecommunications (DECT); Common Interface (CI); Part 1: Overview".
- [2] EN 300 175-2: "Digital Enhanced Cordless Telecommunications (DECT); Common Interface (CI); Part 2: Physical Layer (PHL)".
- [3] EN 300 175-3: "Digital Enhanced Cordless Telecommunications (DECT); Common Interface (CI); Part 3: Medium Access Control (MAC) layer".
- [4] EN 300 175-4: "Digital Enhanced Cordless Telecommunications (DECT); Common Interface (CI); Part 4: Data Link Control (DLC) layer".
- [5] EN 300 175-5: "Digital Enhanced Cordless Telecommunications (DECT); Common Interface (CI); Part 5: Network (NWK) layer".
- [6] EN 300 175-6: "Digital Enhanced Cordless Telecommunications (DECT); Common Interface (CI); Part 6: Identities and addressing".
- [7] EN 300 175-7: "Digital Enhanced Cordless Telecommunications (DECT); Common Interface (CI); Part 7: Security features".
- [8] EN 300 175-8: "Digital Enhanced Cordless Telecommunications (DECT); Common Interface (CI); Part 8: Speech coding and transmission".
- [9] ETS 300 406: "Methods for Testing and Specification (MTS); Protocol and profile conformance testing specifications; Standardization methodology".
- [10] EN 300 444: "Digital Enhanced Cordless Telecommunications (DECT); Generic Access Profile (GAP)".
- [11] EN 300 824: "Digital Enhanced Cordless Telecommunications (DECT); Cordless Terminal Mobility (CTM), CTM Access Profile (CAP)".

- [12] ISO/IEC 9646-1: "Information technology; Open Systems Interconnection; Conformance testing methodology and framework; Part 1: General concepts".
- [13] ISO/IEC 9646-2: "Information technology; Open Systems Interconnection; Conformance testing methodology and framework; Part 2: Abstract Test Suite Specification".

## 3 Definitions and abbreviations

### 3.1 Definitions

For the purposes of the present document, the terms and definitions given in ISO/IEC 9646-1 [12], ISO/IEC 9646-2 [13], EN 300 175-1 [1], EN 300 175-5 [5], EN 300 175-6 [6] and EN 300 175-7 [7] apply.

### 3.2 Abbreviations

For the purposes of the present document, the following abbreviations apply:

AC	Authentication Code
AR	Access Rights
AU	Authentication
BI	Invalid Behaviour
BO	Inopportune Behaviour
BV	Valid Behaviour
CA	Capability
CC	Call Control
CI	Call Information
CISS	Call Independent Supplementary Services
CLMS	Connectionless Message Services
COMS	Connection Oriented Message Services
CR	Call Release
DECT	Digital Enhanced Cordless Telecommunications
FT	Fixed radio Termination
HP	Handover Procedure
IC	Incoming Call
ID	Identification
IPUI	International Portable User Identity
IUT	Implementation Under Test
KA	Key Allocation
LC	Link Control
LE	Connection oriented Link Establishment
LL	Connectionless Link control
LO	Location
LR	Connection oriented Link Release
LS	Connection oriented Link Suspend and resume
LT	Lower Tester
ME	Management Entity
MM	Mobility Management
MO	Connection Oriented Message Services
NWK	Network layer
OC	Outgoing Call
PARK	Portable Access Rights Key
PDU	Protocol Data Unit
PHL	Physical layer
PICS	Protocol Implementation Conformance Statement
PIXIT	Protocol Implementation Extra Information for Testing
PM	Packet Mode
PR	Parameter Retrieval

PT	Portable radio termination
RS	Call Related Supplementary Services
SC	Service Change
TP	Test Purposes
TSS	Test Suite Structure
TTCN	Tree and Tabular Combined Notation
UAK	User Authentication Key



## 4 Test Suite Structure (TSS)

### 4.1 TSS overview

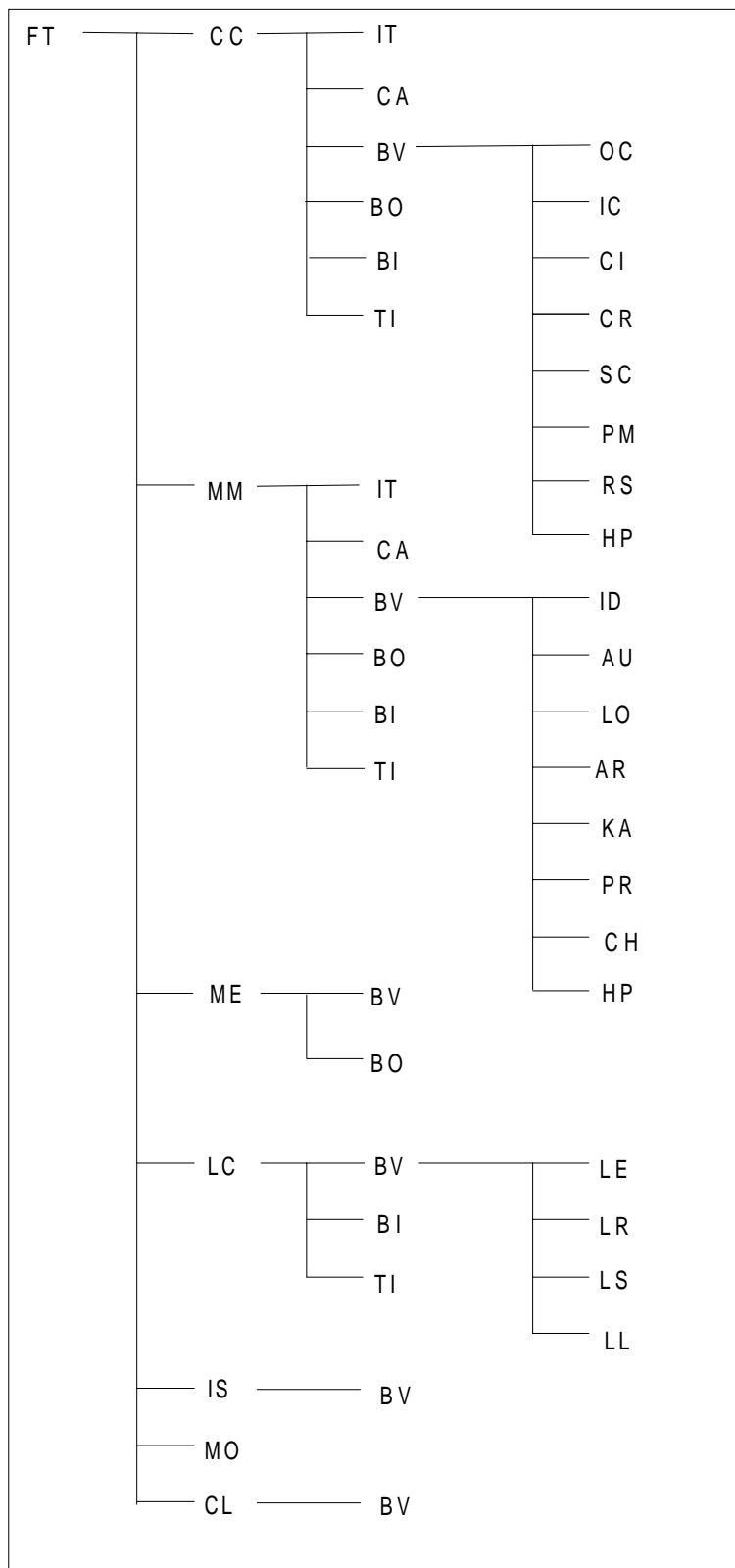

Figure 1: TSS

## 4.2 Test groups

### 4.2.1 Protocol groups

#### 4.2.1.1 Call Control (CC)

Reference: EN 300 175-5 [5], subclause 5.2, clause 9 and subclause 15.7.

#### 4.2.1.2 Mobility Management (MM)

Reference: EN 300 175-5 [5], subclause 5.6, clause 13 and subclause 15.7.

#### 4.2.1.3 Lower layer Management Entity (ME)

Reference: EN 300 175-5 [5], clause 15.

#### 4.2.1.4 Link Control (LC)

Reference: EN 300 175-5 [5], subclause 5.7 and clause 14.

#### 4.2.1.5 Call Independent Supplementary Services (CISS)

Reference: EN 300 175-5 [5], subclauses 5.3 and 10.4.2.2.

#### 4.2.1.6 Connection Oriented Message Services (COMS)

Reference: EN 300 175-5 [5], subclause 5.4 and clause 11.

#### 4.2.1.7 Connectionless Message Services (CLMS)

Reference: EN 300 175-5 [5], subclause 5.5 and clause 12.

### 4.2.2 Main test groups

#### 4.2.2.1 Basic Interconnection tests (IT)

IT tests provide limited testing of an Implementation Under Test (IUT) in order to establish that there is sufficient conformance for possible interconnection without trying to perform thorough testing. In particular, only those test cases will be executed which will assure the sufficient interconnection between the IUT of the NWK layer and the test system exists, so that the rest of the test cases can then be put into execution.

#### 4.2.2.2 Capability tests (CA)

CA tests provide limited testing that the observable capabilities of the IUT are in accordance with the static conformance requirements and the additional capabilities claimed in the Protocol Implementation Conformance Statement / Protocol Implementation Extra Information for Testing (PICS/PIXIT). In particular, this test group can be regarded as a set of spot checks for all the capabilities of the IUT stated in the PICS/PIXIT. Scope of the test group is the observable capabilities of the IUT with respect to NWK layer connection, call control, and the mobility management.

#### 4.2.2.3 Valid Behaviour tests (BV)

BV group tests an IUT in response to valid behaviour of the test system. "Valid" means that a test event is syntactically and contextually correct. All test cases in the valid behaviour group are intended to verify as thoroughly as possible the various functions of the protocol.

#### 4.2.2.4 Invalid Behaviour tests (BI)

BI group is intended to verify that the IUT is able to react properly in case an invalid protocol data unit (message) occurring. Invalid Protocol Data Unit (PDU) here means syntactically or semantically invalid test events generated by the test system. A syntactically or semantically invalid test event regardless of the current state is not allowed.

#### 4.2.2.5 Inopportune Behaviour tests (BO)

BO test group is intended to verify that the IUT is able to react properly in case an inopportune test event occurring. Such an event is syntactically correct, but occurs when it is not allowed.

#### 4.2.2.6 Timer expiry and counter mismatch tests (TI)

Different timers and counters are defined to supervise the various state transitions. This test subgroup is intended to verify that the IUT is reacting properly to an expiry of one of the timers or counters mismatch.

## 5 Test Purposes (TP)

Each test case is allocated directly under a defined TP.

### 5.1 Introduction

#### 5.1.1 TP definition conventions

The TP are defined following particular rules as shown in table 1.

**Table 1: TP definition rules**

TP Id according to the TP naming conventions	Reference Initial condition Stimulus Expected behaviour
TP Id:	The TP Id is a unique identifier it shall be specified according to the TP naming conventions defined in the subclause below.
Reference:	The reference should contain the references of the subject to be validated by the actual TP (specification reference, clause, paragraph).
Condition:	The condition defines in which initial state the IUT has to be to apply the actual TP.
Stimulus:	The stimulus defines the test event to which the TP is related.
Expected behaviour:	Definition of the events that are expected from the IUT to conform to the base specification.

#### 5.1.2 References

This subclause defines the use of references given in the TP. The structure provides the interrelationship with:

- the source EN giving the clause / subclause reference; and
- the profile EN giving the clause / subclause reference.

### 5.1.3 TP naming conventions

The identifier of the TP is built according to table 2.

**Table 2: TP naming convention**

TP/<rt>/<fm>/<x>/<s>/<nn>		
<rt> = type of radio termination	FT	Fixed radio Termination
<fm> = functional module	CC MM ME LC IS MO CL	Call Control Mobility Management Lower Layer Management Entity Link Control Entity Call Independent Supplementary Services Connection Oriented Message Service Connectionless Message Service
x = Type of testing	IT CA BV BO BI TI	Basic Interconnection Tests Capability Tests Valid Behaviour Tests Inopportune Behaviour Tests Invalid Behaviour Tests Timer expiry and counter mismatch tests
s = test subgroup	OC IC CI CR SC PM RS HP ID AU LO AR KA PR CH LE LR LS LL	Outgoing Call establishment Incoming Call establishment Call Information Call Release Service Change Packet Mode Call Related Supplementary services Handover Procedure Identification Authentication Location Access Rights Key Allocation Parameter Retrieval Ciphering Connection oriented Link Establishment Connection oriented Link Release Connection oriented Link Suspend and resume Connectionless Link control
<nn> = sequential number	(01-99)	Test Purpose Number

## 5.2 CC test purposes

Test group objectives:

To check the behaviour of the CC module of the IUT.

Subgroups:

- IT;
- CA;
- BV;
- BO;
- BI;
- TI.

### 5.2.1 CC/IT test purposes

There are no test purposes defined for this group in the present document.

### 5.2.2 CC/CA test purposes

There are no test purposes defined for this group in the present document.

### 5.2.3 CC/BV test purposes

Subgroups:

- OC;
- IC;
- CI;
- CR;
- SC;
- PM;
- RS;
- HP.

### 5.2.3.1 CC/BV/OC test purposes

Test subgroup objectives:

To check the IUT's behaviours to setup an outgoing call.

Test purposes:

TP/FT/CC/BV/OC-01	EN 300 175-5 [5], subclause 9.3.1.4 - subclause 9.3.1.6 <b>EN 300 444 [10], subclause 8.1, figure 1</b> Initial state: F-00 Verify that the IUT is able to perform a CC-state transition from state F-00 to state F-10 for an outgoing normal call, using the piece-wise method to transfer dialling information.
TP/FT/CC/BV/OC-02	EN 300 175-5 [5], subclause 9.3.1.4 - subclause 9.3.1.6 Initial state: F-00 Verify that the IUT is able to perform a CC-state transition from state F-00 to state F-10 for an outgoing normal call set-up with en-block dialling in {CC-SETUP} message.
TP/FT/CC/BV/OC-03 Existing TCL test DECT/T (98) 17 p.14	CAP feature N.2 EN 300 175-5 [5], subclause 9.3.1 EN 300 824 [11], subclause 7.2, table 1 Initial state: F-00 Verify that the IUT is able, prior to subscription, to perform a CC-state transition from state F-00 to state F-10 for an outgoing emergency call set-up.
TP/FT/CC/BV/OC-04 Existing TCL test DECT/T (98) 17 p.14	CAP feature N.2 EN 300 175-5 [5], subclause 9.3.1 EN 300 824 [11], subclause 7.2, table 1 Initial state: F-00 Verify that the IUT is able, when it has a subscription record for the requesting PT, to perform a CC-state transition from the F-00 state to F-10 state for an outgoing emergency call set-up.
TP/FT/CC/BV/OC-05	EN 300 175-5 [5], subclause 9.3.1 Initial state: F-00 Verify that the IUT is able, prior to subscription, to perform a CC-state transition from state F-00 to state F-10 for an outgoing emergency call set-up with piece-wise dialling.
TP/FT/CC/BV/OC-06 CAP/FT/NWK/xy DECT/T (98) 17 p.15	GAP/CAP feature M.13 EN 300 175-3 [3], subclause 11.3.2 EN 300 175-6 [6], subclause 5.6 Initial state: F-00 Verify that the IUT can correctly establish a following outgoing call from the LT when the LT has use SARI as the means to lock to the IUT.
TP/FT/CC/BV/OC-50 CAP/FT/NWK/xx DECT/T (98) 17 p.15	CAP feature M.1 EN 300 824 [11], subclause 11.3 Initial state: F-00 Verify that the IUT can correctly establish a following outgoing call from the LT when the LT has use TARI as the means to lock to the IUT.

### 5.2.3.2 CC/BV/IC test purposes

Test subgroup objectives:

To check the IUT's behaviours to setup an incoming call.

Test purposes:

TP/FT/CC/BV/IC-01	EN 300 175-5 [5], subclause 9.3.2 <b>EN 300 444 [10], subclause 8.11, figure 28</b> Initial state: F-00 Verify that the IUT is able to perform an incoming call via the states F-06 and F-07 to the state F-10.
TP/FT/CC/BV/IC-02	EN 300 175-5 [5], subclause 9.3.2 Initial state: F-00 Verify that the IUT is able to perform an incoming call via state F-06 directly to the state F-10.

### 5.2.3.3 CC/BV/CI test purposes

Test subgroup objectives:

To check the IUT's behaviours for information transfer.

Test purposes:

TP/FT/CC/BV/CI-01	EN 300 175-5 [5], subclause 9.3.1 <b>EN 300 444 [10], subclause 8.14</b> Initial state: F-00 Verify that the IUT is able to send the <<SIGNAL>> information element in case of incoming call to the PT. This information element can either be in the {CC-SETUP} or in successive {CC-INFO} message.
TP/FT/CC/BV/CI-02	EN 300 175-5 [5], subclause 9.3.1.5 <b>EN 300 444 [10], subclause 8.10, table 20</b> Initial state: F-02 Verify that when the IUT receives a {CC-INFO} message with a <<MULTI-KEYPAD>> information element containing keypad-info "12"H (goto pulse), the IUT from that moment on transfers dialling information to the network simulator, using pulse (decadic) dialling (feature N.23 in EN 300 444 [10]).
TP/FT/CC/BV/CI-03	EN 300 175-5 [5], subclause 9.3.1.5 <b>EN 300 444 [10], subclause 8.10, table 20</b> Initial state: F-10 Verify that when the IUT receives a {CC-INFO} message with a <<MULTI-KEYPAD>> information element containing keypad-info "12"H (goto pulse), the IUT from that moment on transfers dialling information to the network simulator, using pulse (decadic) dialling (feature N.23 in EN 300 444 [10]).
TP/FT/CC/BV/CI-04	EN 300 175-5 [5], subclause 9.3.1.5 <b>EN 300 444 [10], subclause 8.10, table 20</b> Initial state: F-02 Verify that when the IUT receives a {CC-INFO} message with a <<MULTI-KEYPAD>> information element containing keypad-info "05H" (dialling pause), it sends a dialling pause to the network simulator (feature N.7 in EN 300 444 [10]).
TP/FT/CC/BV/CI-05	EN 300 175-5 [5], subclause 9.3.1.5 <b>EN 300 444 [10], subclause 8.10, table 20</b> Initial state: F-10 Verify that when the IUT receives a {CC-INFO} message with a <<MULTI-KEYPAD>> information element containing keypad-info "05H" (dialling pause), it sends a dialling pause to the network simulator (feature N.7 in EN 300 444 [10]).
TP/FT/CC/BV/CI-06	EN 300 175-5 [5], subclause 9.3.1.5 <b>EN 300 444 [10], subclause 8.10, table 20</b> Initial state: F-02 Verify that when the IUT receives a {CC-INFO} message with a <<MULTI-KEYPAD>> information element containing keypad-info "14H" (goto DTMF, defined tone length), the IUT from that moment on transfers dialling information to the network simulator, using DTMF with defined tone length (feature N.6 in EN 300 444 [10]).
TP/FT/CC/BV/CI-07	EN 300 175-5 [5], subclause 9.3.1.5 <b>EN 300 444 [10], subclause 8.10, table 20</b> Initial state: F-10 Verify that when the IUT receives a {CC-INFO} message with a <<MULTI-KEYPAD>> information element containing keypad-info "14H" (goto DTMF, defined tone length), the IUT from that moment on transfers dialling information to the network simulator, using DTMF with defined tone length (feature N.6 in EN 300 444 [10]).
TP/FT/CC/BV/CI-08	EN 300 175-5 [5], subclause 9.3.1.5 <b>EN 300 444 [10], subclause 8.10, table 20</b> Initial state: F-02 Verify that when the IUT receives a {CC-INFO} message with a <<MULTI-KEYPAD>> information element containing keypad-info "16H" (goto DTMF, infinite tone length), the IUT from that moment on transfers dialling information to the network simulator, using DTMF with infinite tone length (feature N.22 in EN 300 444 [10]).
TP/FT/CC/BV/CI-09	EN 300 175-5 [5], subclause 9.3.1.5 <b>EN 300 444 [10], subclause 8.10, table 20</b> Initial state: F-10 Verify that when the IUT receives a {CC-INFO} message with a <<MULTI-KEYPAD>> information element containing keypad-info "16H" (goto DTMF, infinite tone length), the IUT from that moment on transfers dialling information to the network simulator, using DTMF with infinite tone length (feature N.22 in EN 300 444 [10]).

TP/FT/CC/BV/CI-10	EN 300 175-5 [5], subclause 9.3.1.5 <b>EN 300 444 [10], subclause 8.10, table 20</b> Initial state: F-10 Verify that when the IUT receives a {CC-INFO} message with a <<MULTI-KEYPAD>> information element containing the basic digits (0-9, star, hash mark), it transfers this information correctly to the network simulator (feature N.4 in EN 300 444 [10]).
-------------------	--

#### 5.2.3.4 CC/BV/CR test purposes

Test subgroup objectives:

To check the IUT's behaviours to release an outgoing and incoming call.

Test purposes:

TP/FT/CC/BV/CR-01	EN 300 175-5 [5], subclause 9.5.1 <b>EN 300 444 [10], subclause 8.7</b> Initial state: F-02 Verify that the IUT is able to perform an IUT initiated normal release.
TP/FT/CC/BV/CR-02	EN 300 175-5 [5], subclause 9.5.1 <b>EN 300 444 [10], subclause 8.7</b> Initial state: F-10 Verify that the IUT is able to perform an IUT initiated normal release.
TP/FT/CC/BV/CR-03	EN 300 175-5 [5], subclause 9.5.1 <b>EN 300 444 [10], subclause 8.7</b> Initial state: F-07 Verify that the IUT is able to perform an IUT initiated normal release.
TP/FT/CC/BV/CR-04	EN 300 175-5 [5], subclause 9.5.1 <b>EN 300 444 [10], subclause 8.7</b> Initial state: F-02 Verify that the IUT, after part of dialling information is sent, is able to perform a PT initiated normal release.
TP/FT/CC/BV/CR-05	EN 300 175-5 [5], subclause 9.5.1 <b>EN 300 444 [10], subclause 8.7</b> Initial state: F-10 Verify that the IUT is able to perform a PT initiated normal release.
TP/FT/CC/BV/CR-06	EN 300 175-5 [5], subclause 9.5.1 <b>EN 300 444 [10], subclause 8.7</b> Initial state: F-07 Verify that the IUT is able to perform a PT initiated normal release.
TP/FT/CC/BV/CR-07	EN 300 175-5 [5], subclause 9.5.1 <b>EN 300 444 [10], subclause 8.8, figure 24</b> Initial state: F-07 Verify that the IUT is able to perform a PT initiated abnormal release.
TP/FT/CC/BV/CR-08	EN 300 175-5 [5], subclause 9.5.1 <b>EN 300 444 [10], subclause 8.8, figure 24</b> Initial state: F-10 Verify that the IUT is able to perform a PT initiated abnormal release.
TP/FT/CC/BV/CR-09	EN 300 175-5 [5], subclause 9.5.1 <b>EN 300 444 [10], subclause 8.8, figure 24</b> Initial state: F-06 Verify that the IUT is able to perform a PT initiated abnormal release.
TP/FT/CC/BV/CR-10	EN 300 175-5 [5], subclause 14.2.7 <b>EN 300 444 [10], subclause 8.9</b> Initial state: F-10 Verify that the IUT is able to perform a PT initiated partial release.



TP/FT/CC/BV/CR-50 CAP/FT/NWK/15 DECT/T (98) 17 p.15	CAP feature N.1 (External handover - call release) EN 300 824 [11], subclause 9.1.4.2.2 Initial state: F-10 Verify that after completing the external handover call setup procedure, the IUT can successfully perform the PT initiated normal CC release procedure.
TP/FT/CC/BV/CR-51 CAP/FT/NWK/16 DECT/T (98) 17 p.15	CAP feature N.1 (External handover - call release) EN 300 824 [11], subclause 9.1.4.2.2 Initial state: F-10 Verify that after completing the external handover call setup procedure, the IUT can successfully perform the FT initiated normal CC release procedure.

### 5.2.3.5 CC/BV/SC test purposes

There are no test purposes defined for this group in the present document.

### 5.2.3.6 CC/BV/PM test purposes

There are no test purposes defined for this group in the present document.

### 5.2.3.7 CC/BV/RS test purposes

Test subgroup objectives:

To check the IUT's behaviour during any call related procedures.

Test purposes:

TP/FT/CC/BV/RS-07 Existing validated GAP test DECT/T (98) 17 p.13	GAP/CAP feature N.30 EN 300 175-5 [5], subclause 10.3 <b>EN 300 444 [10], subclause 8.12, table 21</b> EN 300 824 [11], subclause 7.7, table 3 Initial state: F-00 Verify the IUT is able to transmit the <<calling party number>> information element in the {CC-SETUP} message providing the PP with the calling party number information before accepting the call.
---	---

### 5.2.3.8 CC/BV/HP test purposes

Test subgroup objectives:

To check the behaviour of the CC of the IUT during external handover.

Test purposes:

TP/FT/CC/BV/HP-50 CAP/FT/NWK/01 DECT/T (98) 17 p.13	CAP feature N.1 (Handover candidate indication) EN 300 824 [11], subclause 9.1.1, table 6 Initial state: F-00 Verify that during the establishment of an outgoing call, the IUT transmits a valid <<Ext h/o indicator>> information element in a CC message.
TP/FT/CC/BV/HP-51 CAP/FT/NWK/02 DECT/T (98) 17 p.13	CAP feature N.1 (Handover candidate indication) EN 300 824 [11], subclause 9.1.1, table 6 Initial state: F-00 Verify that during the establishment of an incoming call, the IUT transmits a valid <<Ext h/o indicator>> information element in a CC message.
TP/FT/CC/BV/HP-52 CAP/FT/NWK/05 DECT/T (98) 17 p.13	CAP feature N.1 (Handover reference indication) EN 300 824 [11], subclause 9.1.3, table 7 Initial state: F-00 Verify that during the establishment of an outgoing call, the IUT transmits a valid <<network parameter>> information element in a CC message.
TP/FT/CC/BV/HP-53 CAP/FT/NWK/06 DECT/T (98) 17 p.13	CAP feature N.1 (Handover reference indication) EN 300 824 [11], subclause 9.1.3, table 7 Initial state: F-00 Verify that during the establishment of an incoming call, the IUT transmits a valid <<network parameter>> information element in a CC message.
TP/FT/CC/BV/HP-54 CAP/FT/NWK/07 DECT/T (98) 17 p.14	CAP feature N.1 (Handover candidate call setup) EN 300 824 [11], subclause 9.1.4, table 7 Initial state: F-10 Verify that the IUT is able to perform the external handover call setup procedure and successfully establishes the U-plane on the new connection. The IUT has to provide <ext h/o ind> in the external handover call setup.

### 5.2.4 CC/BO test purposes

Test group objectives:

To check the CC of the IUT in response to the messages that are syntactically correct but not allowed to occur in some states of the CC procedures.

Test purposes:

TP/FT/CC/BO-01	EN 300 175-5 [5], subclause 17.4.1 <b>EN 300 444 [10], subclause 6.9.4.</b> Initial state: F-02 Verify that the IUT ignores the unexpected message {CC-SETUP}
TP/FT/CC/BO-02	EN 300 175-5 [5], subclause 9.5.3 <b>EN 300 444 [10], subclause 8.7.2.1, figure 21.</b> Initial state: F-19 Verify that the IUT is able to react correctly on a release collision, in the sense that upon reception of a {CC-RELEASE} message in state F-19, no {CC-RELEASE-COM} message is sent back, and the call is cleared.

## 5.2.5 CC/BI test purposes

Test group objectives:

To check the Call Control module of the IUT in response to invalid messages.

Test purposes:

TP/FT/CC/BI-01	EN 300 175-5 [5], subclause 17.6.1 <b>EN 300 444 [10], subclause 6.9.4</b> Initial state: F-00 Verify that the IUT sends a {CC-RELEASE-COM} message on receipt of a {CC-SETUP} message without a mandatory information element
TP/FT/CC/BI-02	EN 300 175-5 [5], subclause 17.6.2 <b>EN 300 444 [10], subclause 6.9.4</b> Initial state: F-00 Verify that the IUT sends a {CC-RELEASE-COM} message on receipt of a {CC-SETUP} message containing a mandatory information element with invalid contents
TP/FT/CC/BI-03	EN 300 175-5 [5], subclause 17.4.1 <b>EN 300 444 [10], subclause 6.9.4.</b> Initial state: F-00 Verify that the IUT ignores an unrecognized message, constructed and a {CC-SETUP} but with one bit different in the <message type>

## 5.2.6 CC/TI test purposes

Test group objectives:

To verify that the IUT is reacting properly to an expiry of one of the timers or counters mismatch.

Test purposes:

TP/FT/CC/TI-01	EN 300 175-5 [5], subclause 9.3.1.5 <b>EN 300 444 [10], subclause 8.3.2.3,</b> Initial state: F-02 Verify that the IUT, after having started timer F-<CC.01>, sends a {CC-RELEASE} message when the timer expires after the defined time. The {CC-RELEASE} message should arrive within the allowed margin time of $\pm 5\%$
TP/FT/CC/TI-02	EN 300 175-5 [5], subclause 9.3.1.5 <b>EN 300 444 [10], subclause 8.3.2.3, figure 12</b> Initial state: F-02 Verify that the IUT is able to restart the timer F-<CC.01>, on receipt of a {CC-INFO} message
TP/FT/CC/TI-03	EN 300 175-5 [5], subclause 9.5.1 <b>EN 300 444 [10], subclause 8.7.1.2</b> Initial state: F-19 Verify that the IUT, after having started timer F-<CC.02>, sends a {CC-RELEASE-COM} message when the timer expires after the defined time. The {CC-RELEASE-COM} message should arrive within the allowed margin time of $\pm 5\%$
TP/FT/CC/TI-04	EN 300 175-5 [5], subclause 9.3.2 <b>EN 300 444 [10], subclause 8.12.1.1</b> Initial state: F-06 Verify that the IUT, after having started timer F-<CC.03>, sends a {CC-RELEASE-COM} message when the timer expires after the defined time. The {CC-RELEASE-COM} message should arrive within the allowed margin time of $\pm 5\%$

## 5.3 MM test purposes

Test group objectives:

To check the behaviour of the MM module of the IUT. Most test cases in this group are testing the MM while the CC is in null state or active state.

Subgroups:

- IT;
- CA;
- BV;
- BO;
- BI;
- TI.

### 5.3.1 MM/IT test purposes

There are no test purposes defined for this group in the present document.

### 5.3.2 MM/CA test purposes

There are no test purposes defined for this group in the present document.

### 5.3.3 MM/BV test purposes

Subgroups:

- ID;
- AU;
- LO;
- AR;
- KA;
- PR;
- CH;
- HP.

#### 5.3.3.1 MM/BV/ID test purposes

Test subgroup objectives:

To check the IUT's valid behaviour of identity request procedure.

Test purposes:

TP/FT/MM/BV/ID-01	EN 300 175-5 [5], subclause 13.2.1 <b>EN 300 444 [10], subclause 8.19</b> Initial state: Selected in PIXIT Verify that when the basic IUT initiated identity request procedure is invoked on the IUT, the IUT is able to perform this procedure correctly.
-------------------	---

### 5.3.3.2 MM/BV/AU test purposes

Test subgroup objectives:

To check the IUT's valid behaviour of the authentication procedure.

Test purposes:

TP/FT/MM/BV/AU-01	EN 300 175-5 [5], subclause 13.3.1 <b>EN 300 444 [10], subclause 8.21</b> Initial state: Selected in PIXIT Verify that the IUT, after invocation, is able to perform the basic operation of the authentication of PT procedure (PT has not stored ZAP value and service class information).
TP/FT/MM/BV/AU-02	EN 300 175-5 [5], subclause 13.3.1 <b>EN 300 444 [10], subclause 8.23, figure 49</b> Initial state: Selected in PIXIT Verify that the IUT, after invocation, is able to perform the basic operation of the procedure incrementing the ZAP value, during the authentication of PT procedure (PT has stored ZAP value and service class information). PT will authenticate IUT before answering.
TP/FT/MM/BV/AU-03	EN 300 175-5 [5], subclause 13.3.2 <b>EN 300 444 [10], subclause 8.22</b> Initial state: Selected in PIXIT Verify that the IUT, after invocation, is able to perform the basic operation of the authentication of user procedure (PT has not stored ZAP value and service class information).
TP/FT/MM/BV/AU-04	EN 300 175-5 [5], subclause 13.3.3 <b>EN 300 444 [10], subclause 8.20</b> Initial State: F-10 Verify that the IUT is able to perform the basic operation of the authentication of FT procedure.
TP/FT/MM/BV/AU-05	EN 300 175-5 [5], subclause 13.3.3 <b>EN 300 444 [10], subclause 8.20.2.1, figure 45</b> Initial State: F-00 Verify that the IUT rejects authentication of FT procedure if an authentication key is specified which is not supported by the FT.
TP/FT/MM/BV/AU-06	EN 300 175-5 [5], subclause 13.3.3 <b>EN 300 444 [10], subclause 8.20.2.1, figure 45</b> Initial state: Selected in PIXIT Verify that the IUT is capable to request storage of the DCK and successively use the stored DCK value for ciphering, when it is accepted by the PT.(PT has not stored ZAP value and service class information).

### 5.3.3.3 MM/BV/LO test purposes

Test subgroup objectives:

To check the IUT's valid behaviour of the location procedure.

Test purposes:

TP/FT/MM/BV/LO-01	EN 300 175-5 [5], subclause 13.4.1 <b>EN 300 444 [10], subclause 8.25, figure 50</b> Initial state: F-00 Verify that the IUT is able to perform the basic operation of the location registration procedure, requested with an International Portable User Identity (IPUI), when broadcast attributes bit a38 was set to 1, and still is 1.
TP/FT/MM/BV/LO-02	EN 300 175-5 [5], subclause 13.4.1 <b>EN 300 444 [10], subclause 8.25.2.1, figure 51</b> Initial state: F-00 Verify that the IUT sends back a {LOCATE_REJECT} message, after receiving a {LOCATE_REQUEST} message containing a portable identity on which it does not have a subscription record (IPUI is unknown), when broadcast attributes bit a38 was set to 1, and still is 1.
TP/FT/MM/BV/LO-03	EN 300 175-5 [5], subclause 13.4.1 <b>EN 300 444 [10], subclause 8.25, figure 50</b> Initial state: F-00 Verify that the IUT is able to perform the basic operation of the location registration procedure, requested with an IPUI, while the IUT performs a TPUI assignment in the {LOCATE_ACCEPT} message, when broadcast attributes bit a38 was set to 1, and still is 1.
TP/FT/MM/BV/LO-05	EN 300 175-5 [5], subclause 13.7 <b>EN 300 444 [10], subclause 8.26</b> Initial state: Specified in PIXIT Verify that the IUT, after invocation, is able to perform the basic operation of the FT initiated parameter retrieval procedure as part of the location update procedure, when broadcast attributes bit a38 was set to 1, and still is 1 and the PT starts the location registration procedure upon receipt of the first {MM-INFO-SUGGEST} message.
TP/FT/MM/BV/LO-06	EN 300 175-5 [5], subclause 13.7 <b>EN 300 444 [10], subclause 8.26</b> Initial state: F-00 Verify that the IUT is able to perform the basic operation of the location registration procedure, requested with an IPUI, when broadcast attributes bit a38 was set to 1 during the locking of the IUT, and when it was changed to 0 afterward. (see note)
TP/FT/MM/BV/LO-07	EN 300 175-5 [5], subclause 13.7 <b>EN 300 444 [10], subclause 8.26</b> Initial state: Specified in PIXIT Verify that the IUT, after invocation, is able to perform the basic operation of the FT initiated parameter retrieval procedure as part of the location update procedure, when broadcast attributes bit a38 was set to 1, and still is 1 and the PT starts the location registration procedure upon receipt of the second (MM-INFO-SUGGEST) message.
TP/FT/MM/BV/LO-50 CAP/FT/NWK/12 DECT/T (98) 17 p.15	CAP feature N.5 EN 300 824 [11], subclause 9.5, table 12 Initial state: F-00 Verify that the IUT does not attempt to set up an incoming call to the portable after receipt of a DETACH message.
TP/FT/MM/BV/LO-51 CAP/FT/NWK/13 DECT/T (98) 17 p.15	CAP feature N.6 EN 300 824 [11], subclause 9.6, table 13 Initial state: F-00 Verify that the IUT (FP) is able to transmit a LOCATE-ACCEPT message indicating <Lock limits> and <Time limits> within a <<DURATION>> information element.
TP/FT/MM/BV/LO-52 CAP/FT/NWK/13b DECT/T (98) 17 p.15	CAP feature N.64 [UNTESTABLE] EN 300 824 [11], subclause 9.6, table 13 Initial state: F-00 Verify that the IUT (FP) is able to transmit a LOCATE-REJECT message indicating a <Lock limit> within a <<DURATION>> information element.
NOTE:	The phrase "bit a38 was set to 1" means: The bit a38 had the value of 1 during the time the PT locked to the IUT.

### 5.3.3.4 MM/BV/AR test purposes

Test subgroup objectives:

To check the IUT's valid behaviour of the obtain access rights procedure.

Test purposes:

TP/FT/MM/BV/AR-01	EN 300 175-5 [5], subclause 13.5.1 <b>EN 300 444 [10], subclause 8.27</b> Initial state: No access rights. Bit a44 shall be set in the IUT Verify that the IUT is able to perform the basic operation of the obtain access rights procedure, when the LT sends in the <<AUTH_TYPE>> information element the auth_key_type "AC", and the IUT uses Authentication Code (AC) for authentication. The IUT shall include the whole Portable Access Rights Key (PARK).
TP/FT/MM/BV/AR-02	EN 300 175-5 [5], subclause 13.5.1 <b>EN 300 444 [10], subclause 8.27, table 46</b> Initial state: No access rights. Bit a44 shall be set in the IUT Verify that the IUT is able to assign service class information as part of the basic obtaining access rights procedure.
TP/FT/MM/BV/AR-03	EN 300 175-5 [5], 13.5.2 <b>EN 300 444 [10], subclause 8.28</b> Initial state: Specified in PIXIT Verify that the IUT, after invocation, is able to perform the basic operation of the FT initiated terminate access rights procedure, when the LT successfully authenticates the IUT.
TP/FT/MM/BV/AR-06	EN 300 175-5 [5], subclause 13.5.1 <b>EN 300 444 [10], subclause 8.27</b> Initial state: No access rights. Bit a44 has to be set in the IUT Verify that the IUT is able to perform the basic operation of the obtain access rights procedure, when the LT sends in the <<AUTH_TYPE>> information element the auth_key_type "UAK", and the IUT uses the User Authentication Key (UAK) for authentication. The IUT shall include the whole PARK.
TP/FT/MM/BV/AR-07	EN 300 175-5 [5], subclause 13.5.1 <b>EN 300 444 [10], subclause 8.27, table 46</b> Initial state: No access rights. Bit a44 has to be set in the IUT Verify that the IUT is able to assign zap field as part of the basic obtaining access rights procedure.
TP/FT/MM/BV/AR-50 CAP/FT/NWK/14 DECT/T (98) 17 p.15	CAP feature N.7 EN 300 824 [11], subclause 9.8, table 18 Initial state: T-00 Verify that the IUT is able to successfully perform the On-air modification of user parameters procedure.

### 5.3.3.5 MM/BV/KA test purposes

Test subgroup objectives:

To check the IUT's valid behaviour of the key allocation procedure.

Test purposes:

TP/FT/MM/BV/KA-01	EN 300 175-5 [5], subclause 13.6 <b>EN 300 444 [10], subclause 8.29</b> Initial state: Specified in PIXIT Verify that the IUT, after invocation, is able to perform the basic operation of the key allocation procedure.
TP/FT/MM/BV/KA-02	EN 300 175-5 [5], subclause 13.6 <b>EN 300 444 [10], subclause 8.29.2.4, figure 59</b> Initial state: Specified in PIXIT Verify that the IUT, after invocation of the key allocation procedure, if the authentication of PT as part of this procedure fails, returns an {AUTH-REJECT} message.

### 5.3.3.6 MM/BV/PR test purposes

Test subgroup objectives:

To check the IUT's valid behaviour of the parameter retrieval procedure.

Test purpose:

TP/FT/MM/BV/PR-01	EN 300 175-5 [5], subclause 13.7 Initial state: Specified in PIXIT Check that IUT is able to operate the basic operation of the PT initiated parameter retrieval procedure.
-------------------	---

### 5.3.3.7 MM/BV/CH test purposes

Test subgroup objectives:

To check the IUT's valid behaviours of the ciphering procedure.

Test purposes:

TP/FT/MM/BV/CH-01	EN 300 175-5 [5], subclause 13.8 <b>EN 300 444 [10], subclause 8.31</b> Initial state: F-00 Verify that the IUT is able to correctly perform the basic cipher switching procedure after the PT initiated cipher switching procedure requesting "cipher-on", while no ciphering is active.
TP/FT/MM/BV/CH-02	EN 300 175-5 [5], subclause 13.8 <b>EN 300 444 [10], subclause 8.31</b> Initial state: F-00 Verify that the IUT is able to correctly perform the basic cipher request procedure after the PT initiated cipher switching procedure requesting "cipher-off", while ciphering is active.
TP/FT/MM/BV/CH-03	EN 300 175-5 [5], subclause 13.8 <b>EN 300 444 [10], subclause 8.30</b> Initial state: Specified in PIXIT Verify that the IUT, after invocation, is able to perform the basic operation of FT initiated cipher switching procedure requesting "cipher-on", while no ciphering is active.
TP/FT/MM/BV/CH-04	EN 300 175-5 [5], subclause 13.8 <b>EN 300 444 [10], subclause 8.30</b> Initial state: Specified in PIXIT Verify that the IUT, after invocation, is able to perform the basic operation of FT initiated cipher switching procedure requesting "cipher-off", while ciphering is active.
TP/FT/MM/BV/CH-05	EN 300 175-5 [5], subclause 13.8 <b>EN 300 444 [10], subclause 8.31.2.1, figure 64</b> Initial state: F-00 Verify that the IUT rejects a cipher switching request from the PT when a {CIPHER-SUGGEST} message has been received, containing a not supported cipher key.
TP/FT/MM/BV/CH-08	EN 300 175-7 [7], subclause 6.4.6 <b>EN 300 444 [10], subclause 10.14</b> Initial state: Specified in PIXIT Check that the IUT releases the basic connection when it cannot conclude the procedure to switch from clear mode to encrypt mode (FT initiated cipher-switching).
TP/FT/MM/BV/CH-09	EN 300 175-7 [7], subclause 6.4.6 <b>EN 300 444 [10], subclause 10.14</b> Initial state: F-00 Check that the IUT releases the basic connection when it cannot conclude the procedure to switch from clear mode to encrypt mode (PT initiated cipher-switching).
TP/FT/MM/BV/CH-10	EN 300 175-7 [7], subclause 6.4.7 <b>EN 300 444 [10], subclause 10.15</b> Initial state: F-00 Check that the IUT responds rightly to a PT initiated intercell bearer handover procedure when encryption is enabled (PT initiated cipher-switching).



TP/FT/MM/BV/CH-11	EN 300 175-7 [7], subclause 6.4.7 <b>EN 300 444 [10], subclause 10.15</b> Initial state: F-00 Check that the IUT responds rightly to a PT initiated intracell bearer handover procedure when encryption is enabled (PT initiated cipher-switching).
TP/FT/MM/BV/CH-12	EN 300 175-7 [7], subclause 6.4.7 <b>EN 300 444 [10], subclause 10.15</b> Initial state: Specified in PIXIT Check that the IUT responds rightly to a PT initiated intercell bearer handover procedure when encryption is enabled (PT initiated cipher-switching).
TP/FT/MM/BV/CH-13	EN 300 175-7 [7], subclause 6.4.6 <b>EN 300 444 [10], subclause 10.14</b> Initial state: F-00 Check that the IUT releases the basic connection when it cannot conclude the procedure to switch from encrypt mode to clear mode (PT initiated cipher-switching).
TP/FT/MM/BV/CH-14	EN 300 175-7 [7], subclause 6.4.7 <b>EN 300 444 [10], subclause 10.15</b> Initial state: Specified in PIXIT Check that the IUT responds rightly to a PT initiated intracell bearer handover procedure when encryption is enabled (FT initiated cipher-switching).
TP/FT/MM/BV/CH-15	EN 300 175-5 [5], subclause 13.8 <b>EN 300 444 [10], subclause 8.33</b> Initial state: Specified in PIXIT Verify that the IUT, after invocation, is able to perform the basic operation of FT initiated cipher switching procedure requesting "cipher-off", while ciphering is active.

### 5.3.3.8 MM/BV/HP test purposes

Test subgroup objectives:

To check the behaviour of the MM of the IUT during external handover.

Test purposes:

TP/FT/MM/BV/HP-50 CAP/FT/NWK/03 DECT/T (98) 17 p.13	CAP feature N.1 (Handover candidate retrieval) EN 300 824 [11], subclause 9.1.1.2 Initial state: F-00 Verify that the IUT responds with a valid MM_INFO-ACCEPT message to an MM-INFO-REQUEST message requesting "external handover parameters".
TP/FT/MM/BV/HP-51 CAP/FT/NWK/04 DECT/T (98) 17 p.13	CAP feature N.1 (Handover reference retrieval) EN 300 824 [11], subclause 9.1.3.2, table 8 Initial state: F-00 Verify that the IUT responds with a valid MM_INFO-ACCEPT message to an MM-INFO-REQUEST message requesting "handover reference".
TP/FT/MM/BV/HP-52 CAP/FT/NWK/08 DECT/T (98) 17 p.14	CAP feature N.1 (Handover ciphering PT initiated) EN 300 824 [11], subclause 9.1.4, table 7 Initial state: F-10 Verify that after performing the external handover call setup procedure on a ciphered connection, the IUT is able to successfully perform the PT initiated ciphering procedure on the new connection.
TP/FT/MM/BV/HP-53 CAP/FT/NWK/08.1 DECT/T (98) 17 p.14	CAP feature N.1 (Handover ciphering PT initiated) EN 300 824 [11], subclause 9.1.4, table 7 Initial state: F-10 Verify that after performing the external handover call setup procedure on a ciphered connection, the IUT releases the new connection if ciphering fails on the new connection.
TP/FT/MM/BV/HP-54 CAP/FT/NWK/09 DECT/T (98) 17 p.14	CAP feature N.1 (Handover ciphering FT initiated) EN 300 824 [11], subclause 9.1.4, table 7 Initial state: F-10 Verify that after performing the external handover call setup procedure, the IUT initiates and successfully performs the FT initiated ciphering procedure on the new connection.

### 5.3.4 MM/BO test purposes

Test group objectives:

To check the MM of the IUT in response to the messages that are syntactically correct but not allowed to occur in some phase of The MM procedures.

Test purpose:

TP/FT/MM/BO-01	EN 300 175-5 [5], subclause 17.4.4 <b>EN 300 444 [10], subclause 13.1</b> Initial state: Specified in PIXIT Verify that the IUT ignores the unexpected message {IDENTITY-REPLY} as an answer to the FT initiated {CIPHER-REQUEST}
----------------	--

### 5.3.5 MM/BI test purposes

Test group objectives:

To check the MM module of the IUT in response to invalid messages.

Test purposes:

TP/FT/MM/BI-02	EN 300 175-5 [5], subclause 17.6.4 <b>EN 300 444 [10], subclause 6.9.4</b> Initial state: No access rights. Bit a44 has to be set in the IUT Verify that the IUT, during the obtain access rights procedure, returns an {ACCESS-RIGHTS-REJECT} message, on receipt of an {ACCESS-RIGHTS-REQUEST} message missing the information element <<AUTH-TYPE>>.
TP/FT/MM/BI-03	EN 300 175-5 [5], subclause 17.6.4 <b>EN 300 444 [10], subclause 6.9.4</b> Initial state: No access rights. Bit a44 has to be set in the IUT Verify that the IUT, during the obtain access rights procedure, returns an {ACCESS-RIGHTS-REJECT} message, on receipt of an {ACCESS-RIGHTS-REQUEST} message containing the information element <<AUTH-TYPE>> with a length exceeding the maximum allowed length.

### 5.3.6 MM/TI test purposes

Test group objectives:

This test subgroup is intended to verify that the IUT is reacting properly to an expiry of one of the timers or counters mismatch.

Test purposes:

TP/FT/MM/TI-01	EN 300 175-5 [5], subclause 13.2.1 <b>EN 300 444 [10], subclause 8.19.2.2</b> Initial state: Specified in PIXIT Verify that the IUT is capable of completing the Identification of PT procedure at a point in time 10 % before expiry of the timer F-<MM_ident.2>.
TP/FT/MM/TI-02	EN 300 175-5 [5], subclause 13.3.1 <b>EN 300 444 [10], subclause 8.21.2.2</b> Initial state: Specified in PIXIT Verify that the IUT is capable of completing the Authentication of PT procedure at a point in time 10 % before expiry of the timer F-<MM_auth.1>.
TP/FT/MM/TI-03	EN 300 175-5 [5], subclause 13.3.2 <b>EN 300 444 [10], subclause 8.22.2.2.</b> Initial state: Specified in PIXIT Verify that the IUT is capable of completing the Authentication of User procedure at a point in time 10 % before expiry of the timer F-<MM_auth.2>.
TP/FT/MM/TI-04	EN 300 175-5 [5], subclause 13.5.2 <b>EN 300 444 [10], subclause 8.28.2.2</b> Initial state: F-00 Verify that the IUT is capable of completing the FT Termination of access rights procedure at a point in time 10 % before expiry of the timer F-<MM_access.2>.
TP/FT/MM/TI-05	EN 300 175-5 [5], subclause 13.6 <b>EN 300 444 [10], subclause 8.29.2.1</b> Initial state: Specified in PIXIT Verify that the IUT is capable of completing the FT Key allocation procedure at a point in time 10 % before expiry of the timer F-<MM_key.1>.
TP/FT/MM/TI-06	EN 300 175-5 [5], subclause 13.8 <b>EN 300 444 [10], subclause 8.30.2.1</b> Initial state: Specified in PIXIT Verify that the IUT is capable of completing the FT initiated cipher-switching procedure at a point in time 10 % before expiry of the timer F-<MM_cipher.1>.
TP/FT/MM/TI-07	EN 300 175-5 [5], subclause 13.2.2 <b>EN 300 444 [10], subclause 8.25</b> Initial state: F-00 Verify that the IUT, when during the location registration procedure with TPUI assignment, the timer F-<MM_ident.1> expires after the defined time, aborts the procedure, and thus allows a new location registration procedure to proceed.

### 5.4 ME test purposes

Subgroups:

- BV;
- BO.

### 5.4.1 ME/BV test purposes

Test group objective:

To check interleaving operation of MM entity and CC entity of the IUT.

Test purposes:

TP/FT/ME/BV-01	EN 300 175-5 [5], subclause 15.2.1 <b>EN 300 444 [10], subclause 6.9.6</b> Initial state: Specified in PIXIT Verify that the IUT is able to handle the authentication of FT request in parallel with an incoming call establishment.
TP/FT/ME/BV-02	EN 300 175-5 [5], subclause 15.5 <b>EN 300 444 [10], subclause 6.9.6</b> Initial state: Specified in PIXIT Verify that the IUT is able to handle an authentication of FT request, when it interrupts a user authentication procedure.
TP/FT/ME/BV-03	EN 300 175-5 [5], subclause 15.5 <b>EN 300 444 [10], subclause 6.9.6</b> Initial state: F-10 Verify that the IUT is able to handle an locate request, during an active CC call (state F-10)

### 5.4.2 ME/BO test purposes

Test group objective:

To check the inopportune behaviour of the interleaving operation of MM entity and CC entity of the IUT.

Test purpose:

There are no test purposes defined for this group in the present document.

## 5.5 LC test purposes

Test group objectives:

To verify the behaviour of the LC entity of the IUT.

Subgroups:

- BV;
- BI;
- TI.

### 5.5.1 LC/BV test purposes

Subgroups:

- LE;
- LR;
- LS;
- LL.

### 5.5.1.1 LC/BV/LE test purposes

Test group objective:

To check the IUT's valid behaviour of establishing connection oriented link procedure.

Test purposes:

TP/FT/LC/BV/LE-01	EN 300 175-5 [5], subclause 14.2.1 - subclause 14.2.3 <b>EN 300 444 [10], subclause 8.32, figure 65</b> Initial state: F-00 Verify that the IUT is able to initiate the indirect (paged) FT-initiated link establishment procedure.
TP/FT/LC/BV/LE-02	EN 300 175-5 [5], subclause 14.2.1 - subclause 14.2.3 <b>EN 300 444 [10], subclause 8.32.2.1, figure 66</b> Initial state: F-00 Verify that the IUT rejects the {LCE-PAGE-RESPONSE} with mismatching IPUI during indirect (paged) FT-initiated link establishment and releases the link.
TP/FT/LC/BV/LE-03	EN 300 175-5 [5], subclause 14.2.1 - subclause 14.2.3 <b>EN 300 444 [10], subclause 8.32.2.1, figure 66</b> Initial state: F-00 Verify that the IUT is able to handle a PT initiated link establishment.

### 5.5.1.2 LC/BV/LR test purposes

Test group objective:

To check the IUT's valid behaviour of the connection oriented link release procedure.

Test purposes:

TP/FT/LC/BV/LR-01	EN 300 175-5 [5], subclause 14.2.7 <b>EN 300 444 [10], subclause 8.34</b> Initial state: F-00 Verify that the IUT is able to perform a normal PT initiated link release.
TP/FT/LC/BV/LR-02	EN 300 175-5 [5], subclause 14.2.5 <b>EN 300 444 [10], subclause 8.36</b> Initial state: F-00 Verify that the IUT is able to maintain the link for a specified time, before releasing it, after the termination of an MM procedure. No other entities are using the link
TP/FT/LC/BV/LR-03	EN 300 175-5 [5], subclause 14.2.5 <b>EN 300 444 [10], subclause 8.36</b> Initial state: F-10 Verify that the IUT is able to start the link release after the termination of a call.
TP/FT/LC/BV/LR-04	EN 300 175-5 [5], subclause 14.2.5 <b>EN 300 444 [10], subclause 8.36</b> Initial state: F-10 Verify that the IUT is able to maintain the link for a specified time, before releasing it, after a CC requested partial release has been agreed on, and no other entities are using the link

NOTE: In some cases a lower layer may be responsible for a link release.

### 5.5.1.3 LC/BV/LS test purposes

Test subgroup objectives:

To check the IUT's valid behaviour of connection oriented link suspend and resume procedures.

Test purposes:

There are no test purposes defined for this group in the present document.

### 5.5.1.4 LC/BV/CL test purposes

Test subgroup objectives:

To check the IUT's valid behaviour of connectionless link control procedures.

Test purposes:

There are no test purposes defined for this group in the present document.

### 5.5.2 LC/BI test purposes

Test group objectives:

To check the LC entity of the IUT in response to invalid messages.

Test purposes:

TP/FT/LC/BI-01	EN 300 175-5 [5], subclause 17.1 <b>EN 300 444 [10], subclause 6.9.4</b> Initial state: F-00 Verify that the IUT ignores a message containing a protocol discriminator value that indicates a service that is not supported by the IUT.
TP/FT/LC/BI-04	EN 300 175-5 [5], subclause 17.3.1 <b>EN 300 444 [10], subclause 6.9.4</b> Initial state: F-00 Verify that the IUT ignores an {AUTH-REQUEST} message containing an illegal transaction identifier.
TP/FT/LC/BI-05	EN 300 175-5 [5], subclause 17.3.2.5 <b>EN 300 444 [10], subclause 6.9.4</b> Initial state: Selected in PIXIT Verify that the IUT ignores an {IDENTITY-REPLY} message with a Transaction Identifier flag set illegally to "0", if the message was received during a FT-initiated identification of PT procedure.
TP/FT/LC/BI-07	EN 300 175-5 [5], subclause 17.9 <b>EN 300 444 [10], subclause 8.35</b> Initial state: F-10 Verify that the IUT, when the link fails during an active call, clears the call.

### 5.5.3 LC/TI test purposes

This test subgroup is intended to verify that the IUT is reacting properly to an expiry of one of the timers or counters mismatch.

TP/FT/LC/TI-02	EN 300 175-5 [5], subclause 14.2.7 <b>EN 300 444 [10], subclause 8.36.1.1</b> Initial state: F-00 Verify that the IUT, after termination of an MM procedure, maintains the link for a period of <LCE.02>. The link shall be released in the period (<LCE_02> - 1 000) ms to 10 500 ms.
----------------	---

## 5.6 IS test purposes

Subgroups:

- BV.

## 5.6A IS/BV test purposes

Test group objective:

To verify the behaviour of the IS entity of the IUT.

Test purposes:

TP/FT/IS/BV-01	EN 300 175-5 [5], subclause 10.3 Initial state: F-00 Verify that the IUT sends back a <<Feature Indicate>>, upon reception of a set-up of a CISS procedure containing a <<Feature Activate>> information element.
TP/FT/IS/BV-02	EN 300 175-5 [5], subclause 10.3 Initial state: F-00 Verify that the IUT sends back a <<Facility>> information element, upon reception of a set-up of a CISS procedure containing a <<Facility>> information element.
TP/FT/IS/BV-03	EN 300 175-5 [5], subclause 10.3 Initial state: F-00 Verify that the IUT, after invocation, can set-up a CISS procedure <<Facility>> information element.
TP/FT/IS/BV-50 CAP/FT/NWK/11 DECT/T (98) 17 p.14	CAP feature N.4 EN 300 824 [11], subclause 9.7 - subclause 9.7.1, table 16 Initial state: F-00 Verify that the IUT as part of a Message waiting indication activation procedure sends correctly a notification for message waiting.
TP/FT/IS/BV-51 CAP/FT/NWK/11a DECT/T (98) 17 p.14	CAP feature N.4 EN 300 824 [11], subclause 9.7 - subclause 9.7.2, table 17 Initial state: F-00 Verify that the IUT as part of a Message waiting indication deactivation procedure sends correctly a notification with <numberOfMessages> equal to zero.

## 5.7 MO test purposes

There are no test purposes defined for this group in the present document.

## 5.8 CL test purposes

Subgroups:

- BV.

## 5.9 CL/BV test purposes

Test group objectives:

To verify the behaviour of the CL entity of the IUT.

Test purposes:

TP/FT/CL/BV-01	EN 300 175-5 [5], subclause 12.3.1 Initial state: F-00 Verify that the IUT, after invocation, is able to send a CLMS-FIXED message.
TP/FT/CL/BV-02	EN 300 175-5 [5], subclause 14.2.1 - subclause 14.2.3 Initial state: F-00 Verify that the IUT, after invocation, is able to send a CLMS-VARIABLE. message.
TP/FT/CL/BV-03	EN 300 175-5 [5], subclause 14.2.1 - subclause 14.2.3 Initial state: F-00 Verify that the IUT is able to receive a CLMS-VARIABLE message.

---

## Bibliography

The following material, though not specifically referenced in the body of the present document (or not publicly available), gives supporting information.

- EWOS/ETSI Project Team No 5: "Project Report and Technical Report. OSI Conformance Testing Methodology and Procedures in Europe".
- ETR 022: "Advanced Testing Methods (ATM); Vocabulary of terms used in communications protocols conformance testing".
- ETR 141: "Methods for Testing and Specification (MTS); Protocol and profile conformance testing specifications; The Tree and Tabular Combined Notation (TTCN) style guide".
- CEPT Recommendation T/SGT SF2 (89) 6/0: "Draft Recommendation T/SF Services and Facilities of Digital Enhanced Cordless Telecommunications".
- ETR 015: "Digital Enhanced Cordless Telecommunications (DECT); Reference document".
- ETR 041: "Transmission and Multiplexing (TM); Digital Enhanced Cordless Telecommunications (DECT); Transmission aspects 3,1 kHz telephony Interworking with other networks".
- ETR 042: "Digital Enhanced Cordless Telecommunications (DECT); A Guide to DECT features that influence the traffic capacity and the maintenance of high radio link transmission quality, including the results of simulations".
- ETR 043: "Digital Enhanced Cordless Telecommunications (DECT); Common interface; Services and Facilities requirements specification".
- ETR 056: "Digital Enhanced Cordless Telecommunications (DECT); System description document".
- Directive 98/13/EC of the European Parliament and of the Council of 12 February 1998 relating to telecommunications terminal equipment and satellite earth station equipment, including the mutual recognition of their conformity.
- TBR 6: "Digital Enhanced Cordless Telecommunications (DECT); General terminal attachment requirements".
- TBR 10: "Digital Enhanced Cordless Telecommunications (DECT); General terminal attachment requirements; Telephony applications".
- TBR 22: "Attachment requirements for terminal equipment for Digital Enhanced Cordless Telecommunications (DECT) Generic Access Profile (GAP) applications".



---

## History

<b>Document history</b>		
Edition 1	August 1996	Publication as ETS 300 497-8
Edition 2	February 1998	Publication as ETS 300 497-8
V0.3.0	August 1998	Public Enquiry PE 9852: 1998-08-28 to 1998-12-25
V0.3.2	June 1999	Vote V 9934: 1999-06-07 to 1999-08-20
V0.3.2	September 1999	Publication